

# PROJECT GENERAL NOTES

- THE CONTRACT DOCUMENTS INCLUDE THE WORKING DRAWINGS, ANY ADDENDA, MODIFICATIONS, THE CONDITIONS OF THE CONSTRUCTION CONTRACT, AND SPECIFICATIONS AS NOTED ON THE DRAWINGS.
- THE CONTRACT DOCUMENTS ARE INSTRUMENTS OF SERVICE AND SHALL REMAIN THE PROPERTY OF THE ARCHITECT WHETHER THE PROJECT FOR WHICH THEY ARE PREPARED IS EXECUTED OR NOT. THE CONTRACT DOCUMENTS ARE NOT TO BE USED BY THE OWNER FOR OTHER PROJECTS OR EXTENSIONS TO THE PROJECT NOR ARE THEY TO BE MODIFIED IN ANY MANNER WHATSOEVER EXCEPT BY AGREEMENT IN WRITING AND WITH APPROPRIATE COMPENSATION TO THE ARCHITECT.
- THE WORK WILL CONFORM WITH THE REQUIREMENTS OF ALL AGENCIES HAVING JURISDICTION.
- FURNISH MEANS SUPPLY ONLY FOR OTHERS TO PUT IN PLACE.
- PROVIDE MEANS FURNISH AND INSTALL, COMPLETE AND IN PLACE.
- SIMILAR MEANS COMPATIBLE CHARACTERISTICS FOR CONDITIONS NOTED. CONTRACTOR TO VERIFY DIMENSIONS AND ORIENTATION.
- TYPICAL MEANS IDENTICAL FOR CONDITIONS NOTED.
- DO NOT SCALE DRAWINGS. DIMENSIONS GOVERN. VERIFY DIMENSIONS WITH FIELD CONDITIONS. IF DISCREPANCIES ARE DISCOVERED BETWEEN FIELD CONDITIONS AND DRAWINGS OR BETWEEN DRAWINGS, CONTACT ARCHITECT FOR RESOLUTION BEFORE PROCEEDING.
- HORIZONTAL DIMENSIONS INDICATED ARE TO AND FROM FINISHED FACE OF CONSTRUCTION, EXCEPT AS NOTED.
- VERTICAL DIMENSIONS ARE FROM TOP OF FLOOR SLAB OR DECK, EXCEPT WHERE NOTED TO BE ABOVE FINISH FLOOR (A.F.F.).
- DIMENSIONS ARE NOT ADJUSTABLE WITHOUT APPROVAL OF ARCHITECT UNLESS NOTED.
- ALL WORK SHALL BE ERECTED AND INSTALLED PLUMB, LEVEL, SQUARE, AND TRUE AND IN PROPER ALIGNMENT.
- COORDINATE AND PROVIDE BLOCKING/BACKING IN PARTITIONS BEHIND ALL WALL-MOUNTED ITEMS. ALL CONCEALED WOOD TO BE FIRE TREATED.
- MAKE ALL NECESSARY PROVISIONS FOR ITEMS TO BE FURNISHED OR INSTALLED BY TENANT. PROVIDE PROTECTION FOR THESE PROVISIONS UNTIL COMPLETION OF THE PROJECT. GENERAL CONTRACTOR TO COORDINATE N.J.C. ITEMS WITH APPROPRIATE TRADES.
- GENERAL CONTRACTOR SHALL BE RESPONSIBLE FOR CHECKING CONTRACT DOCUMENTS, FIELD CONDITIONS, AND DIMENSIONS FOR ACCURACY AND CONFIRMING THAT WORK IS BUILDABLE AS SHOWN BEFORE PROCEEDING WITH CONSTRUCTION. CLARIFICATIONS REGARDING ANY CONFLICTS SHALL BE ACHIEVED BEFORE RELATED WORK IS STARTED.
- GENERAL CONTRACTOR SHALL VERIFY THAT NO CONFLICTS EXIST IN LOCATIONS OF ANY AND ALL MECHANICAL, TELEPHONE, ELECTRICAL, PLUMBING, AND SPRINKLING EQUIPMENT (TO INCLUDE ALL PIPING, DUCTWORK AND CONDUIT) AND THAT ALL REQUIRED CLEARANCES FOR INSTALLATION AND MAINTENANCE OF ABOVE EQUIPMENT ARE PROVIDED. ELEMENTS TO BE EXPOSED OR CONCEALED SHALL BE DETERMINED AND REVIEWED WITH ARCHITECT IN THE FIELD PRIOR TO CONSTRUCTION PROCEEDING.
- GENERAL CONTRACTOR AND SUB-CONTRACTORS SHALL COORDINATE THE LAYOUT AND EXACT LOCATION OF PARTITIONS, DOORS, ELECTRICAL/TELEPHONE OUTLETS AND LIGHT SWITCHES WITH ARCHITECT IN THE FIELD BEFORE PROCEEDING WITH CONSTRUCTION.
- GENERAL CONTRACTOR SHALL PROVIDE MANUFACTURER'S SPECIFICATIONS INSTALLATION INSTRUCTIONS, SHOP DRAWINGS AND SAMPLES FOR REVIEW AND APPROVAL OF ALL MATERIALS AND METHODS TO BE USED PRIOR TO ORDERING OR PROCEEDING WITH THE WORK.
- EXERCISE EXTREME CARE AND PRECAUTION DURING CONSTRUCTION OF THE WORK TO MINIMIZE DISTURBANCES TO ADJACENT STRUCTURES AND THEIR OCCUPANTS, PROPERTY, PUBLIC THROUGHFARES, ETC. CONTRACTOR SHALL TAKE PRECAUTIONS AND BE RESPONSIBLE FOR THE SAFETY OF ALL BUILDING OCCUPANTS FROM CONSTRUCTION PROCEDURES.
- WITHIN FIVE (5) DAYS FROM CONTRACT DATE, PREPARE AND SUBMIT AN ESTIMATED PROGRESS SCHEDULE FOR THE WORK, WITH SUB SCHEDULES OF RELATED ACTIVITIES SUCH AS DATA/TELEPHONE CABLING AND FURNITURE INSTALLATION.
- ALL WORK SHALL COMPLY WITH APPLICABLE CODES, AMENDMENTS, RULES, REGULATIONS, ORDINANCES, LAWS, ORDERS, APPROVALS, ETC. THAT ARE REQUIRED BY PUBLIC AUTHORITIES. IN THE EVENT OF CONFLICT, THE MOST STRINGENT REQUIREMENTS SHALL GOVERN. REQUIREMENTS INCLUDE, BUT ARE NOT NECESSARILY LIMITED TO, THE CURRENT APPLICABLE EDITIONS OF THE NEW JERSEY STATE BUILDING AND CONSTRUCTION CODES WHICH ARE RECORDED ON THE COVER SHEET OF THIS SET, AS FOUND ON THE WEBSITE OF THE NJ DEPARTMENT OF COMMUNITY AFFAIRS AS OF THE DATE OF COMMENCEMENT FOR THIS PROJECT.
- ABBREVIATIONS USED IN REFERRING TO STANDARDS THAT APPLY TO THE WORK INCLUDE, BUT ARE NOT LIMITED TO THE FOLLOWING:
  - AMERICAN SOCIETY OF TESTING MATERIALS - ASTM
  - AMERICAN WELDING SOCIETY - AWS
  - AMERICAN NATIONAL STANDARDS INSTITUTE - ANSI
  - ALUMINIUM ASSOCIATION, INC. - AA
  - NATIONAL ASSOC. OF ARCHT. METAL MANU'FS - NAAMM
  - NATIONAL WOODWORK MANU'FS ASSOCIATION - NWWA
  - AMERICAN INSTITUTE OF STEEL CONSTRUCTION - AISC
  - AMERICAN CONCRETE INSTITUTE - ACI
  - ARCHITECT, ALUMINIUM MANU'FS ASSOCIATION - AAMA
  - CONCRETE REINFORCING STEEL INSTITUTE - CRSI
  - NATIONAL FIRE PROTECTION ASSOCIATION - NFPA
  - AMERICAN WOODWORK INSTITUTE - AWI
- IN THE EVENT OF CONFLICTS BETWEEN DATA SHOWN ON DRAWINGS AND DATA SHOWN ON THE SPECIFICATIONS, THE SPECIFICATIONS SHALL GOVERN. DIMENSIONS NOTED ON DRAWINGS SHALL TAKE PRECEDENCE OVER SCALED DIMENSIONS. DETAIL DRAWINGS TAKE PRECEDENCE OVER DRAWINGS OF SMALLER SCALE. SHOULD THE CONTRACTOR AT ANY TIME DISCOVER AN ERROR IN A DRAWING OR SPECIFICATION, OR A DISCREPANCY OR VARIATION BETWEEN DIMENSIONS OR DRAWINGS, AND MEASUREMENTS AT SITE, OR LACK OF DIMENSIONS OR OTHER INFORMATION, HE SHALL NOT PROCEED WITH THE AFFECTED WORK UNTIL CLARIFICATION HAS BEEN MADE.
- ONLY NEW ITEMS OF RECENT MANUFACTURE, OF STANDARD QUALITY, FREE FROM DEFECTS WILL BE PERMITTED ON THE WORK. REJECTED ITEMS SHALL BE REMOVED IMMEDIATELY FROM THE WORK AND BE REPLACED WITH ITEMS OF THE QUALITY SPECIFIED. FAILURE TO REMOVE REJECTED ITEMS AND EQUIPMENT SHALL NOT RELIEVE THE CONTRACTOR FROM THE RESPONSIBILITY FOR QUALITY AND CHARACTER OF ITEMS USED NOR FROM ANY OTHER OBLIGATION IMPOSED ON HIM BY THE CONTRACT.
- THE FINISHED WORK SHALL BE FIRM, WELL ANCHORED, IN TRUE ALIGNMENT, PLUMB, LEVEL, WITH SMOOTH, CLEAN, UNIFORM APPEARANCE; WITHOUT WAVES, DISTORTIONS, HOLES, MARKS, CRACKS, STAINS OR DISCOLOR. JOINTS SHALL BE CLOSE FITTING, NEAT AND WELL SCRIBED. THE FINISH WORK SHALL HAVE NO EXPOSED, UNSIGHTLY ANCHORS OR FASTENERS AND SHALL NOT PRESENT HAZARDOUS OR UNSAFE CORNERS. ALL WORK SHALL HAVE THE PROVISIONS FOR EXPANSION, CONTRACTION, AND SHRINKAGE AS NECESSARY TO PREVENT CRACKS, BUCKLING, AND WARPING DUE TO TEMPERATURE AND HUMIDITY CONDITIONS.
- ATTACHMENTS, CONNECTIONS, OR FASTENERS OF ANY NATURE ARE TO BE PROPERLY AND PERMANENTLY SECURED IN CONFORMANCE WITH BEST PRACTICE AND THE CONTRACTOR IS RESPONSIBLE FOR IMPROVING THEM ACCORDINGLY AND TO THESE CONDITIONS. THE DRAWINGS SHOW ONLY SPECIAL CONDITIONS TO ASSIST CONTRACTOR; THEY DO NOT ILLUSTRATE EVERY SUCH DETAIL.
- THE CONTRACTOR IS RESPONSIBLE FOR VERIFYING THE DIMENSIONS AND ELEVATIONS AT THE SITE. THE CONTRACTOR AND SUB-CONTRACTORS SHALL COORDINATE THE LAYOUT AND EXACT LOCATIONS OF ALL PARTITIONING, DOORS, ELECTRICAL/TELEPHONE OUTLETS, LIGHT SWITCHES AND THERMOSTATS WITH THE OWNER/AGENT IN THE FIELD BEFORE PROCEEDING WITH CONSTRUCTION.
- NO WORK DEFECTIVE IN CONSTRUCTION OR QUALITY OR DEFICIENT IN ANY REQUIREMENTS OF DRAWINGS AND SPECIFICATIONS WILL BE ACCEPTABLE IN CONSEQUENCE OF OWNER'S OR ARCHITECT'S FAILURE TO DISCOVER OR TO POINT OUT DEFECTS OR DEFICIENCIES DURING CONSTRUCTION; NOR WILL PRESENCE OF INSPECTORS ON WORK SITE RELIEVE CONTRACTOR FROM RESPONSIBILITY FOR SECURING QUALITY AND PROGRESS OF WORK AS REQUIRED BY CONTRACT. DEFECTIVE WORK REVEALED WITHIN REQUIRED TIME GUARANTEES SHALL BE REPLACED BY WORK CONFORMING WITH INTENT OF CONTRACT, NO PAYMENT, WHETHER PARTIAL OR FINAL, SHALL BE CONSIDERED AS AN ACCEPTANCE OF DEFECTIVE WORK OR IMPROPER MATERIALS.
- MATERIALS AND WORKMANSHIP SPECIFIED BY REFERENCE TO NUMBER, SYMBOL, TITLE OF SPECIFICATION SUCH AS COMMERCIAL STANDARDS, FEDERAL SPECIFICATIONS, TRADE ASSOCIATION STANDARD OR OTHER SIMILAR STANDARDS, SHALL COMPLY WITH REQUIREMENTS IN THE LATEST EDITION OR REVISION THEREOF AND WITH ANY AMENDMENT OR SUPPLEMENT THERETO IN EFFECT ON DATE OF ORIGIN OF THIS PROJECTS CONTRACT DOCUMENTS. SUCH STANDARDS, EXCEPT AS MODIFIED HEREIN, SHALL HAVE FULL FORCE EFFECTS AS THOUGH PRINTED IN CONTRACT DOCUMENTS.
- CONTRACTOR SHALL WAIVE "COMMON PRACTICE" AND "COMMON USAGE" AS CONSTRUCTION CRITERIA WHEREVER DETAILS AND CONTRACT DOCUMENTS OR GOVERNING CODES, ORDINANCES, ETC. REQUIRE GREATER QUANTITY OR BETTER QUALITY THAN COMMON PRACTICE OR COMMON USAGE.
- CONTRACTOR SHALL ORDER AND SCHEDULE DELIVERY OF MATERIALS IN AMPLIFIED TIME TO AVOID DELAYS IN CONSTRUCTION. IF AN ITEM IS FOUND TO BE UNAVAILABLE, CONTRACTOR SHALL NOTIFY THE OWNER IMMEDIATELY TO ALLOW THE OWNER A REASONABLE AMOUNT OF TIME TO SELECT A SUITABLE SUBSTITUTION.
- IF AT ANY TIME BEFORE COMMENCEMENT OF WORK, OR DURING PROGRESS THEREOF, CONTRACTOR'S METHODS, EQUIPMENT, OR APPLIANCES ARE INAPPROPRIATE FOR SECURING QUALITY OF WORK OR RATE OF PROGRESS INTENDED BY CONTRACT DOCUMENTS, OWNER MAY ORDER CONTRACTOR TO IMPROVE THEIR QUALITY OR INCREASE EFFICIENCY. THIS WILL NOT RELIEVE CONTRACTOR OF HIS SURETIES FROM THEIR OBLIGATIONS TO SECURE QUALITY OF WORK AND RATE OF PROGRESS SPECIFIED IN CONTRACT.
- WITH REFERENCE TO CEILINGS, CONTRACTOR SHALL COORDINATE WITH ALL TRADES INVOLVED TO INSURE THAT CONFLICTS DO NOT OCCUR BETWEEN LIGHT FIXTURES, DUCTWORK, DIFFUSERS, ETC., AND THAT THE CEILING HEIGHTS INDICATED ON DRAWINGS ARE ACHIEVED.
- REFERENCE TO MAKES, BRANDS, ETC., IS TO ESTABLISH TYPE AND QUALITY DESIRED; SUBSTITUTIONS OF ACCEPTABLE EQUALS WILL BE PERMITTED WITH OWNERS APPROVAL UNLESS SPECIFICALLY NOTED OTHERWISE WHEN MADE ACCORDING TO PROCEDURES FOR SUBSTITUTIONS.
- CONTRACTOR SHALL APPLY FOR, PAY FOR, AND OBTAIN ALL REQUIRED PERMITS FOR CONSTRUCTION AND OCCUPANCY.
- PROVIDE SHOP AND/OR SUBMITTALS FOR THE FOLLOWING ITEMS AT THE OWNERS REQUEST:
  - MILLWORK, CASEWORK, AND HARDWARE
  - FLOOR FINISHES
  - DOORS, DOOR HARDWARE + HOLLOW METAL FRAMES
  - LIGHTING, EXIT SIGNAGE, AND EMERGENCY DEVICES
  - FINISH CARPENTRY
  - ACOUSTICAL CEILING TILE AND GRID
  - ALUMINIUM FRAMES
  - ELECTRICAL DEVICES
  - GLAZING
  - WALL FINISHES
  - MECHANICAL EQUIPMENT
- PRIOR TO SUBMITTING A QUOTATION FOR THIS WORK, THE CONTRACTOR SHALL REVIEW THESE DRAWINGS AND SPECIFICATIONS AND SHALL VISIT THE SITE TO FAMILIARIZE HIMSELF (THEMSELVES) WITH EXISTING CONDITIONS AND LIMITATIONS. THE CONTRACTOR SHALL NOTIFY THE OWNER AS SOON AS POSSIBLE OF ANY NOTABLE DISCREPANCIES.
- WORK SHALL BE PERFORMED IN STRICT ACCORDANCE WITH APPLICABLE FIRE, HEALTH, SAFETY AND BUILDING CODES OF THE STATE AND LOCAL JURISDICTION IN WHICH THE PREMISES ARE SITUATED, WORKING CONDITIONS TO COMPLY WITH FEDERAL OCCUPATIONAL SAFETY AND HEALTH ACT GUIDELINES. CONTRACTORS SHALL REMOVE OR REPAIR ALL CONDITIONS NOT IN ACCORDANCE WITH STATE AND LOCAL CODES.
- ALL WORK SHALL BE FREE OF DEFECTS FOR A PERIOD OF ONE (1) YEAR FROM DATE OF SUBSTANTIAL COMPLETION. ALL SUCH DEFECTS SHALL BE CORRECTED BY THIS CONTRACTOR (S) AT NO EXPENSE TO THE OWNER.
- THE CONTRACTOR SHALL PROVIDE ALL LABOR, GOODS AND SERVICES REQUIRED TO COMPLETE THE WORK IN GOOD ORDER AND ON TIME, IN ACCORDANCE WITH THE CONSTRUCTION SCHEDULE SUBMITTED BEFORE COMMENCING WORK.
- GENERAL CONTRACTOR SHALL BE RESPONSIBLE FOR DEBRIS REMOVAL. DO NOT ALLOW DEBRIS TO ACCUMULATE. PROVIDE ADEQUATE DUST AND NOISE BARRIERS. ALL AREAS SHALL BE LEFT BROOM CLEAN DAILY. WASH AND CLEAN ALL WORK AFFECTED BY CONSTRUCTION AT COMPLETION OF PROJECT. PROVIDE WEATHER BARRIERS AS REQUIRED. ALL COMPLETED OR ADJACENT WORK SHALL BE PROTECTED. ALL RUBBISH AND DEBRIS REMOVED ON A DAILY BASIS, AND THE PREMISES DELIVERED TO THE LANDLORD, READY FOR TENANT. CLEAN ALL EXPOSED SURFACES, INCLUDING GLAZING. CONTRACTOR SHALL BE RESPONSIBLE FOR ALL TRASH REMOVAL. COORDINATE WITH LANDLORD FOR SOURCE OF WATER DURING CONSTRUCTION.
- CONTRACTOR SHALL BE RESPONSIBLE FOR KEYING ALL REQUIRED LOCK SETS AND COORDINATING WITH OWNER TO ENSURE THAT CYLINDERS ARE KEED TO BUILDING MASTER KEY SYSTEM AND THAT SUFFICIENT NUMBER OF KEYS ARE SUPPLIED AT TIME OF SUBSTANTIAL COMPLETION.
- THE GENERAL CONTRACTOR SHALL BE RESPONSIBLE FOR ADEQUATE FIRE EXTINGUISHERS IN HIS WORK SPACE TO COMPLY WITH ALL FIRE REGULATIONS THROUGHOUT THE DURATION OF CONSTRUCTION. CONTRACTORS SHALL COMPLY WITH ALL FEDERAL AND LOCAL SAFETY REGULATIONS IN THE EXECUTION OF THEIR WORK.
- THESE DRAWINGS ARE TO BE USED FOR THE PROJECT AND SITE SPECIFICALLY IDENTIFIED HEREIN AND MAY NOT BE USED ON ANY OTHER PROJECT.
- FIELD INVESTIGATIONS SHALL BE MADE TO THE EXTENT NECESSARY TO INSURE NO BUILDING OR ADJACENT TENANT SERVICES ARE DISTURBED OR INTERRUPTED WITHOUT PRIOR PERMISSION OF THE OWNER.
- THE EXIT AND EMERGENCY LIGHTS SHOWN ARE FOR GUIDANCE. THE CONTRACTOR SHALL VERIFY/COORDINATE WITH LOCAL INSPECTOR FOR EXACT QUANTITY AND LOCATIONS.
- CONTRACTOR SHALL INSPECT ALL SUBSTRATES PRIOR TO INSTALLING FINISH MATERIALS. INSTALLATION OF FINISH MATERIALS WITH LOCAL SUBCONTRACTORS INDICATES ACCEPTANCE OF SUBSTRATE AND THAT THE SUBSTRATE IS ACCEPTABLE FOR THAT SPECIFIC FINISH.

# BUILDING CODE SUMMARY FOR ALL COMMERCIAL PROJECTS (EXCEPT 1 AND 2-FAMILY DWELLINGS AND TOWNHOUSES)

Name of Project: NC WAKE BOATS  
 Address: 143 HOLLY SPRINGS CHURCH ROAD Zip Code: 27505  
 Proposed Use: SHOWROOM & WORKSHOP  
 Owner/Authorized Agent: DAVID TURNER Phone # (910) 928-1104 Email: david@ncwakeboats.com  
 Owned By: City / County Private  
 Code Enforcement Jurisdiction: City County: MOORE State

LEAD DESIGN PROFESSIONAL	ROBERT PENNINGTON, ENGINEER
DESIGNER	FIRM NAME LICENSE # TELEPHONE #
Architectural	FDR ENGINEERS Heath M Hendrick 035655 (910) 427-0501
Civil	Arnold Land Design James David Arnold 036865 (910) 630-2552
Electrical	FDR ENGINEERS Robert Pennington 025045 (910) 520-0278
Fire Alarm	BY OTHERS defemled
Plumbing	FDR ENGINEERS Robert Pennington 025045 (910) 520-0278
Mechanical	FDR ENGINEERS Robert Pennington 025045 (910) 520-0278
Sprinkler-Standpipe	
Structural Foundation	FDR ENGINEERS Heath M Hendrick 035655 (910) 427-0501

2018 NC BUILDING CODE FOR:  New Construction  Addition  Upfit  
 2018 EXIST. BUILDING CODE FOR:  Reconstruction  Alteration  Repair  Renovation  
 CONSTRUCTED: (date) CURRENT USE(S) (Ch. 3):  
 RENOVATED: (date) PROPOSED USE(S) (Ch. 3): B & S-1

BUILDING DATA:  
 Construction Type:  I-A  II-A  III-A  IV  V-A  
 I-B  II-B  III-B  V-B  
 Mixed Construction:  No  Yes Types

FLOOR	EXIST. (GR SQ FT)	NEW (GR SQ FT)	SUB-TOTAL
Mezzanine [505.2 not as bldg. area]		< 1,672 sf >	< 1,672 sf >
1st Floor	10,043 sf		10,043 sf
TOTAL		10,043 sf	10,043 sf

## ALLOWABLE AREA

Primary Occupancy: Business  Educational  Mercantile   
 Storage  S-1 Moderate  S-2 Low  High-piled

Mixed Occupancy:  No  Yes Separation: NA Hr. Exception:  Non-Separated Use (508.3)

The required type of construction for the building shall be determined by applying the height and area limitations for each of the applicable occupancies to the entire building. The most restrictive type of construction, so determined, shall apply to the entire building.

- Frontage area increases from Section 506.2 are computed thus:
  - a. Perimeter which fronts a public way or open space having 20 feet minimum width = 498' (F)
  - b. Total Building Perimeter = 498' (P)
  - c. Ratio (F/P) = 1 (F/P)
  - d. W = Minimum width of public way = 24' (W)

$$100 [(24 \times W) + (F \times W) + (P \times W)] / [(24 \times 30) + (29.65) + (498 \times 30)] = 74.1\%$$

e. Percent of frontage increase  $I_f = 100 [F/P - 0.25] \times W/30 = 74.1\%$

$$100 [(490/490) - 0.25] \times 29.6 / 30 = 74.12\%$$

STORY NO.	DESCRIPTION AND USE	(A) BLDG AREA PER STORY (ACTUAL)	(B) TABLE 503.5 AREA	(C) AREA FOR FRONTAGE INCREASE 1	(D) AREA FOR SPRINKLER INCREASE 2	(E) ALLOWABLE AREA OR UNLIMITED 3	(F) MAXIMUM BLDG AREA 4
1	B. SHOWROOM	6,523	9,000	+74%	NA	NA	15,660
1	S-1. WORKSHOP	3,520	9,000	+74%	NA	NA	15,660

BUILDING HEIGHT IN FEET	ALLOWABLE (TABLE 503)	SHOWN ON PLANS	CODE REFERENCE
Building Height in Feet	40'	28'	
Building Height in Stories	(B) 2 / (S-1) 1	1 / 1	

USE	505.2.1		505.2.3 - enclosed	
	area	Ex. 1	area	Ex. 3
[B] SHOWROOM	3,251	1,056	32.48 v	8 v 768 - 77.72 - X
[S1] STORAGE MEZZANINE	2,870	488	17.00 v	53 - 10.86 - X

## FIRE PROTECTION REQUIREMENTS

BUILDING ELEMENT	FIRE SEPARATION (FEET)	RATING	PROVIDED (W/ REDUCTIONS)	DETAIL # AND SHEET #	DESIGN # FOR RATED ASSEMBLY	SHEET # FOR RATED PENETRATION	SHEET # FOR RATED JOINTS
Structural frame, including columns, girders, and trusses		NA					
Bearing walls		NA					
Exterior		NA					
North		NA					
East		NA					
West [602, F.S.D.]	10' max < 30'	0hrs					
South		NA					
Interior		NA					
Nonbearing walls and partitions		NA					
Exterior Walls		NA					
North		NA					
East		NA					
West		NA					
South		NA					
Interior walls and partitions		NA					
Floor construction		NA					
Including supporting beams and joists		NA					
Floor-Ceiling Assembly		NA					
Columns Supporting Floors		NA					
Roof construction		NA					
Including supporting beams and joists		NA					
Roof-Ceiling Assembly		NA					
Columns Supporting Roof		NA					
Shaft Enclosures - Exit		NA					
Shaft Enclosures - Others		NA					
Corridor Separation		NA					
Occupancy Separation		NA					
Party Fire Wall Separation		NA					
Smoke Barrier Separation		NA					
Tenant Separation		NA					
Incidental Use Separation		NA					

## LIFE SAFETY SYSTEM REQUIREMENTS

Emergency Lighting:  No  Yes  
 Exit Signs:  No  Yes  
 Fire Alarm:  No  Yes  
 Smoke Detection Systems:  No  Yes  Partial AHU RA Duct Detectors  
 Carbon Monoxide Detection:  No  Yes

## LIFE SAFETY PLAN REQUIREMENTS

- Life Safety Plan Sheet #: CS
- Fire and/or smoke rated wall locations (Chapter 7)
  - Assumed and real property line locations (if not on the site plan)
  - Exterior wall opening area with respect to distance to assumed property lines (705.8)
  - Occupancy Use for each area as it relates to occupant load calculation (Table 1004.1.2)
  - Occupant loads for each area
  - Exit access travel distances (1017)
  - Exit access travel distances (Tables 1006.2.1 & 1006.3.2(1))
  - Dead end lengths (1020.4)
  - Clear exit widths for each exit door
  - Max. calculated occ. load capacity each exit door can accommodate based on egress width (1005.3)
  - Actual occupant load for each exit door
  - A separate schematic plan indicating where fire rated floor/ceiling and/or roof structure is provided for purposes of occupancy separation
  - Location of doors with panic hardware (1010.11.0)
  - Location of doors with delayed egress locks and the amount of delay (1010.1.9.7)
  - Location of doors with electromagnetic egress locks (1010.1.9.9)
  - Location of doors equipped with hold-open devices
  - Location of emergency escape windows (1030)
  - The square footage of each fire area (202)
  - The square footage of each smoke compartment for Occupancy Classification 1-2 (407.5)
  - Note any code exceptions or table notes that may have been utilized regarding the items above

## EXIT REQUIREMENTS

FLOOR, ROOM OR SPACE DESIGNATION	NUMBER OF EXITS	MINIMUM 2 NUMBER OF EXITS	TRAVEL DISTANCE	ARRANGEMENT MEANS OF EGRESS 3 (SECTION 1007.1.1)
BUILDING	2	7	200'	132'
SHOWROOM LEVEL	1	4	200'	7'
OFFICE MEZZANINE	1	1	200'	132'
WORKSHOP	1	3	200'	53'
STORAGE MEZZANINE	1	1	200'	102'

- Corridor dead ends (Section 1020.4)
- Single exits (Table 1006.3.1). Spaces with one egress (Table 1006.2.1)
- Common Path of Travel (Section 1006.1.2)

## EXIT WIDTH

USE GROUP OR SPACE DESCRIPTION	AREA		CALCULATED OCCUPANT LOAD	EGRESS WIDTH PER OCCUPANT (TABLE 1003.3)	REQUIRED WIDTH (TABLE 1003.3)		ACTUAL WIDTH (a) x (b) x c
	(a) %	(b)			(a)	(b)	
BUILDING			37	NA	0.2	NA	7.4' NA 34'
SHOWROOM [B]			28	NA	0.2	NA	5.6' NA 34'
OFFICE MEZZANINE [B]			(11)	0.3	0.2	3.3'	2.2' 36' 34'
WORKSHOP [S1]			9	NA	0.2	NA	1.8' NA 34'
STORAGE MEZZANINE [S1]			(2)	0.3	0.2	0.6'	0.4' 36' 34'

## BONDING OF METAL VENEERS

ELECTRICAL CONTRACTOR SHALL PROVIDE ADEQUATE BONDING OF THE INSTALLED METAL VENEER PANELS, PURSUANT TO SECTION 250 OF THE 2020 NFPA-70 (NEC) WITH NORTH CAROLINA AMENDMENTS AND TO THE SATISFACTION OF THE LOCAL ELECTRICAL CODE OFFICIAL/INSPECTOR HAVING AUTHORITY.

description	sq. ft.	IBC Use class	sq. ft. gross	code	occupant	area
veranda	962	warehouse	500 gross	2	2	
office - grade	498	business areas	100 gross	9	4	
office - 2nd	1,076	business areas	100 gross	11	11	
showroom	3,251	warehouse	500 gross	7	7	
pool enclosure	1,300	warehouse	500 gross	3	3	
						8 occupants = 1
shop	3,900	warehouse	500 gross	7	7	
storage - meat	800	accessory storage areas	300 gross	2	2	
						5-1 occupants = 9
						total occupants = 37

use	total occ.	per gender	W.C.	lav.	D.F.	S.S.	code
B	14	F	M	F	M	F	referenc
required: 1 1 1 1 1 1 NA 1 403.2(2)							
provided: 1 1 1 1 1 NA 1 403.3.1							

use	total occ.	per gender	W.C.	lav.	D.F.	S.S.	code
S-1	14	F	M	F	M	F	referenc
required: 1 1 1 1 1 1 NA 1 403.2(2)							
provided: 1 1 1 1 1 NA 1 403.3.1							

location	described requirements	prescribed
ROOF:	R-30ci insulation entirely above deck	R-13 FG BATT's in truss cavities and R-30 perpendicular atop
WALLS:	R-13 + R-3.8ci BATT's in cavity + board/roll BATT's in cavities	R-21 FG BATT's between studs
SLAB:	R-15 for 24" @ perimeter	24" of 2" polysty rigid board

# NC WakeBoats

## Broadway, NC

## INDEX

STRUCTURAL	C5	CODE, PROJECT DATA	H/W								
S0.1		LIFE SAFETY	H/W								
S1.0		STRUCTURAL NOTES	H/W								
S1.1		LIFT TRAILING	H/W								
S2.1		FOUNDATION	H/W								
S2.2		ROOF FRAMING - SCHEDULES	H/W								

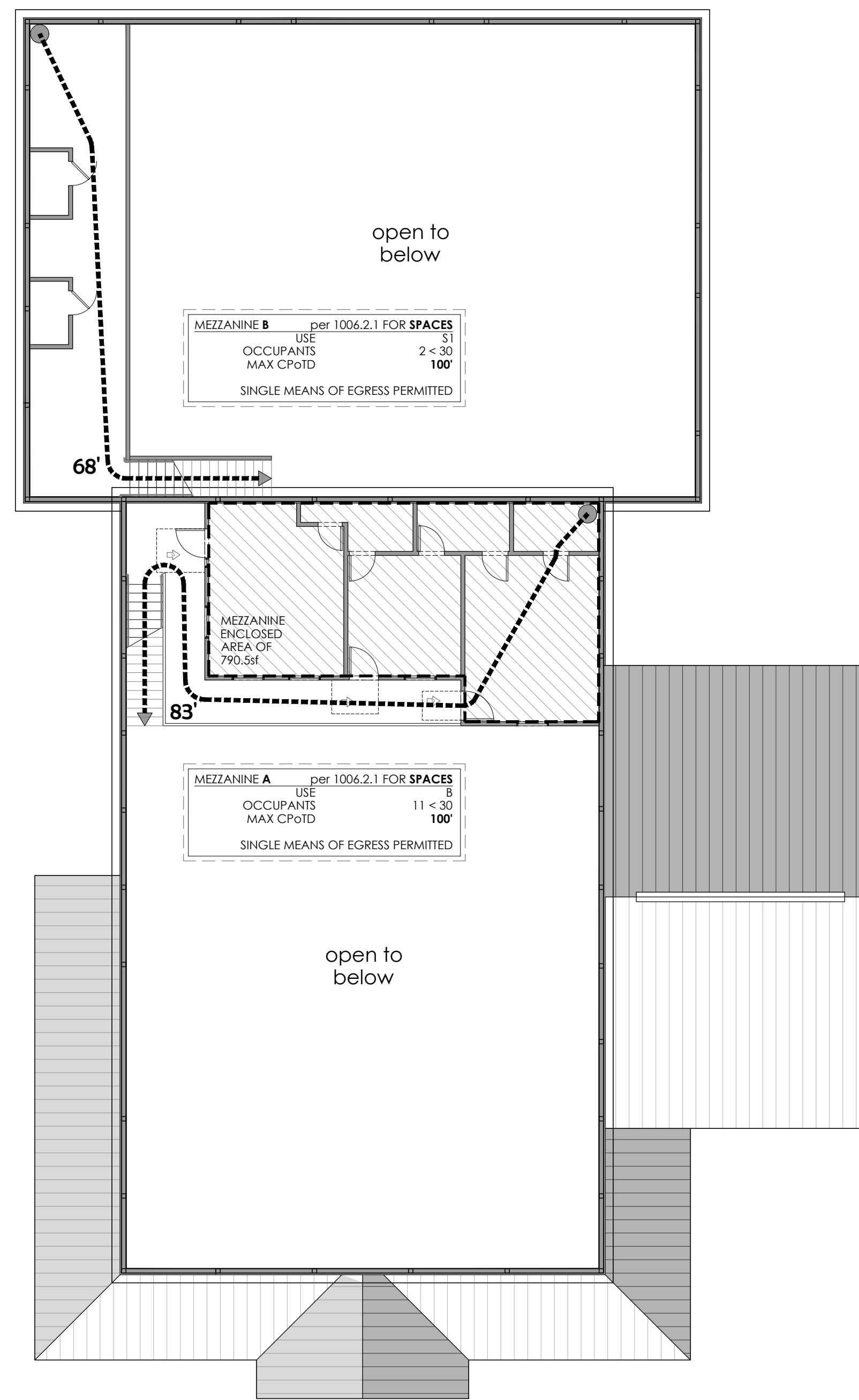

2 2nd LEVEL LIFE SAFETY LAYOUT  
 scale : N.T.S.

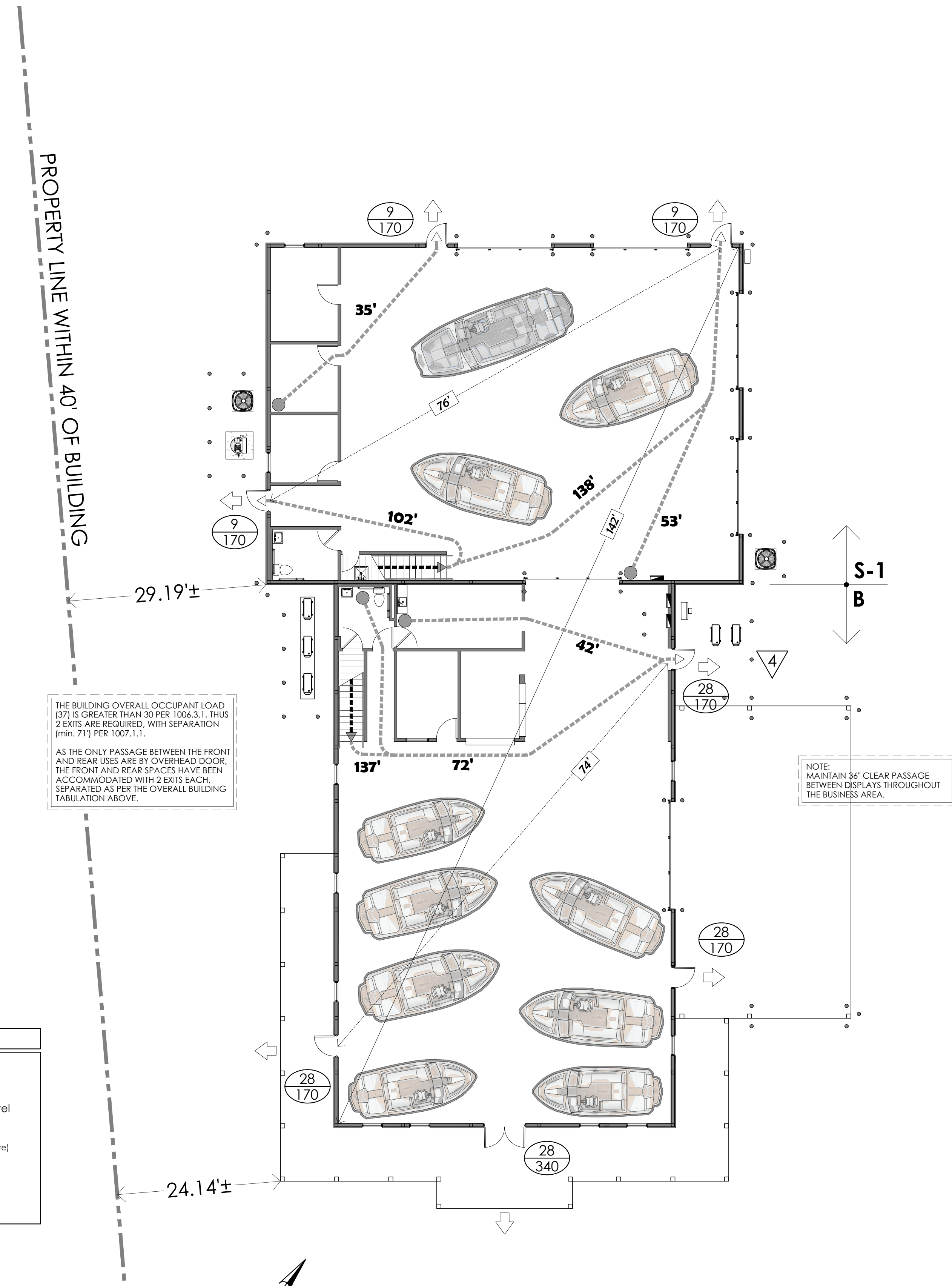
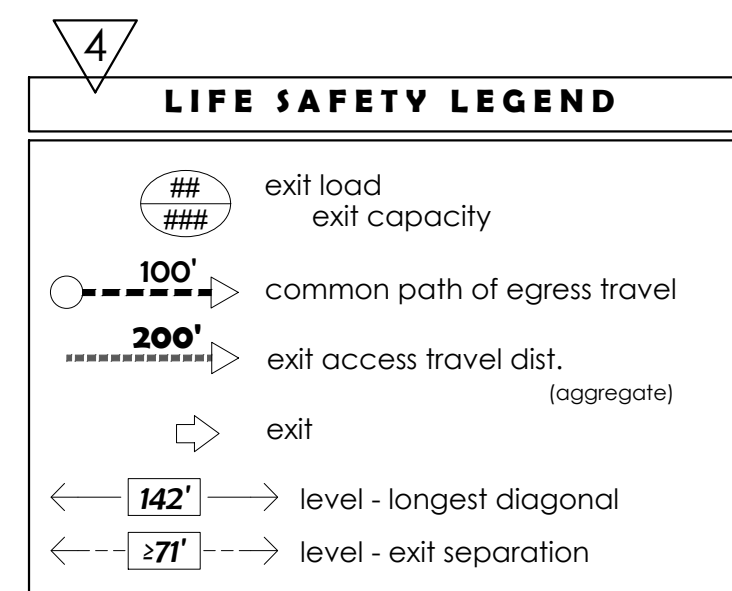

1 GRADE LIFE SAFETY LAYOUT  
 scale : N.T.S.

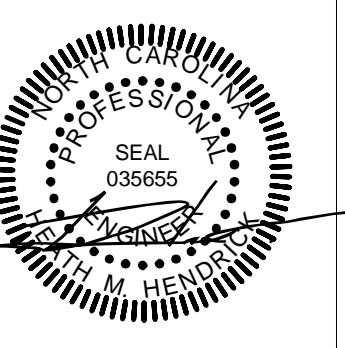

DESIGNED BY: SMB  
 DRAWN BY: SMB  
 APPROVED BY: RLP  
 PROJECT #: R2408270  
 DATE: 2024-10-23

#	Revision	Date
0	for permit	11/25/24
1	BCO comments	01/23/25
2	1ph + HVAC	04/16/25
3	int. off. + mezz.	02/26/26
4	BCO comments	04/02/26

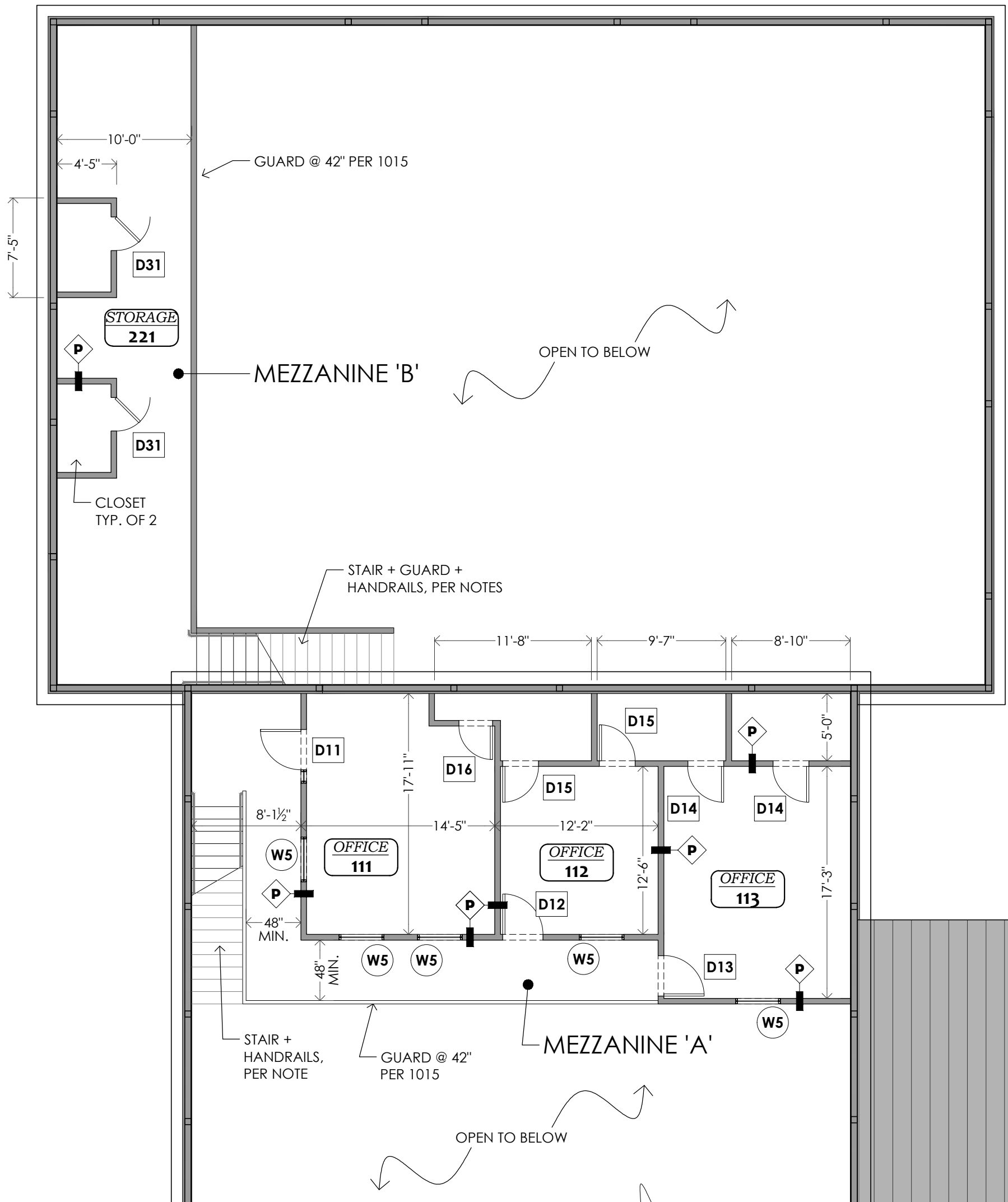

**2 PROPOSED MEZZANINE LAYOUT**  
scale: 1/8" = 1'-0"

**DOOR SCHEDULE** ~ VERIFY ALL PARAMETERS WITH OWNER ~

MARK	QTY	TYPE	LOCATION	HAND	NOM. OPENING	GLAZ.	FRAME MAT.	DOOR MAT.	NOTES
D1	1	A	MAIN ENTRANCE	2x	72" 84"	Y	P.B.O.	P.B.O.	1 2 4 5 6 8 G
D2	2	B	SHOWROOM	RHR	36" 84"	Y	P.B.O.	P.B.O.	1 2 4 5 6 8 G
D2L	1	B	SHOWROOM	LHR	36" 84"	Y	P.B.O.	P.B.O.	1 2 4 5 6 8 G
D3	3	C	WORKSHOP	LHR	36" 84"	N	P.B.O.	P.B.O.	1 2 4 5 6 8
D8	2	C	RESTROOM	LHR	36" 84"	N	P.B.O.	P.B.O.	2 8 9 NC
D8a	1	C	RR CLOSET	RHR	36" 84"	N	P.B.O.	P.B.O.	2 8
D9	1	D	OFFICE	RH	36" 84"	Y	P.B.O.	P.B.O.	1 7 8
D11	1	D	OFFICE	LHR	36" 84"	Y	P.B.O.	P.B.O.	1 7 8 SL
D12	1	D	OFFICE	LH	36" 84"	Y	P.B.O.	P.B.O.	1 7 8
D13	1	D	OFFICE	RH	36" 84"	Y	P.B.O.	P.B.O.	1 7 8 NC
D14	2	C	CLOSET	RHR	36" 84"	N	P.B.O.	P.B.O.	2 8
D15	2	C	CLOSET	LHR	36" 84"	N	P.B.O.	P.B.O.	2 8
D16	1	C	UTILITY CLOSET	RHR	36" 84"	N	P.B.O.	P.B.O.	2 8
D21	1	C	RESTROOM	RH	36" 84"	N	P.B.O.	P.B.O.	2 8 9
D22	2	C	UTILITY CLOSET	RH	30" 84"	N	P.B.O.	P.B.O.	2 8
D23	1	E	OFFICE	RH	36" 84"	Y	P.B.O.	P.B.O.	1 7 8
D24	2	E	OFFICE	RH	36" 84"	Y	P.B.O.	P.B.O.	1 7 8
D31	2	C	CLOSET	RHR	36" 84"	N	P.B.O.	P.B.O.	2 8
OH1	1	—	CANOPY	OHD	16" 12"	N	P.B.O.	P.B.O.	1 4 5 G I O P
OH2	2	—	WORKSHOP	OHD	14" 14"	N	P.B.O.	P.B.O.	1 4 5 G I O P
OH3	2	—	WORKSHOP	OHD	14" 12"	N	P.B.O.	P.B.O.	1 4 5 G I O P
OH4	1	—	INTERIOR	OHD	14" 14"	N	P.B.O.	P.B.O.	1 4 5 G I O P

**NOTES**

1 KEYS DEADBOLT LOCK	7 ACCESSIBLE LOCK	8 INSULATED CORE CONCRETE
2 MONORAIL HANDLES	8 FLOOR WALL STOP	9 OBTURATED OPER. V.W.O.
3 CRASH BAR PANIC HDWR	9 PRIVACY LOCK	10 ENTRAPMENT PROTECTION
4 THRESHOLD & FLOOR SWEEP	10 KEYS CYLINDER LOCK	11 MAG FLOOR STOP
5 PERIMETER GASKET	1 TOP & BOTTOM TRACK	12 <b>CANNOT HAVE CLOSER</b>
6 CLOSERS	12 LOW-E GLAZING	13 SLIGHT PER OWNER

**3 STAIR + EDGE PROTECTION**

parameter	requirement	reference
<b>STAIRS</b>		
RISER	MAX. 7"	~1011.5.2
TREAD	MIN. 11"	~1011.5.2
WIDTH	MIN. 36" CLEAR	~1011.2 Ex.1
& GUARDS	@ 34"-38" A.F.F.	~1104.4
	PER 1015	~1011.13
<b>HANDRAILS</b>		
WHERE	BOTH SIDES	~1011.1.1
HEIGHT	@ 34"-38" A.F.F.	~1014.2
EXTENSIONS	12" @ TOP	
&	1 TREAD @ BOTTOM	~1014.6
&	CORNERS	~Ex.4
<b>GUARDS</b>		
WHERE	@ 30" A.F.F.	1015.2
HEIGHT	42" A.F.F.	1015.3
OPENINGS	MAX. 4" @ F.F.-42"	
&	MAX. 2" @ BOTTOM	1015.4
&	MAX. 4" @ 36"-42" Ex.1	
&	MAX. 6" @ STAIR Δ	Ex.2

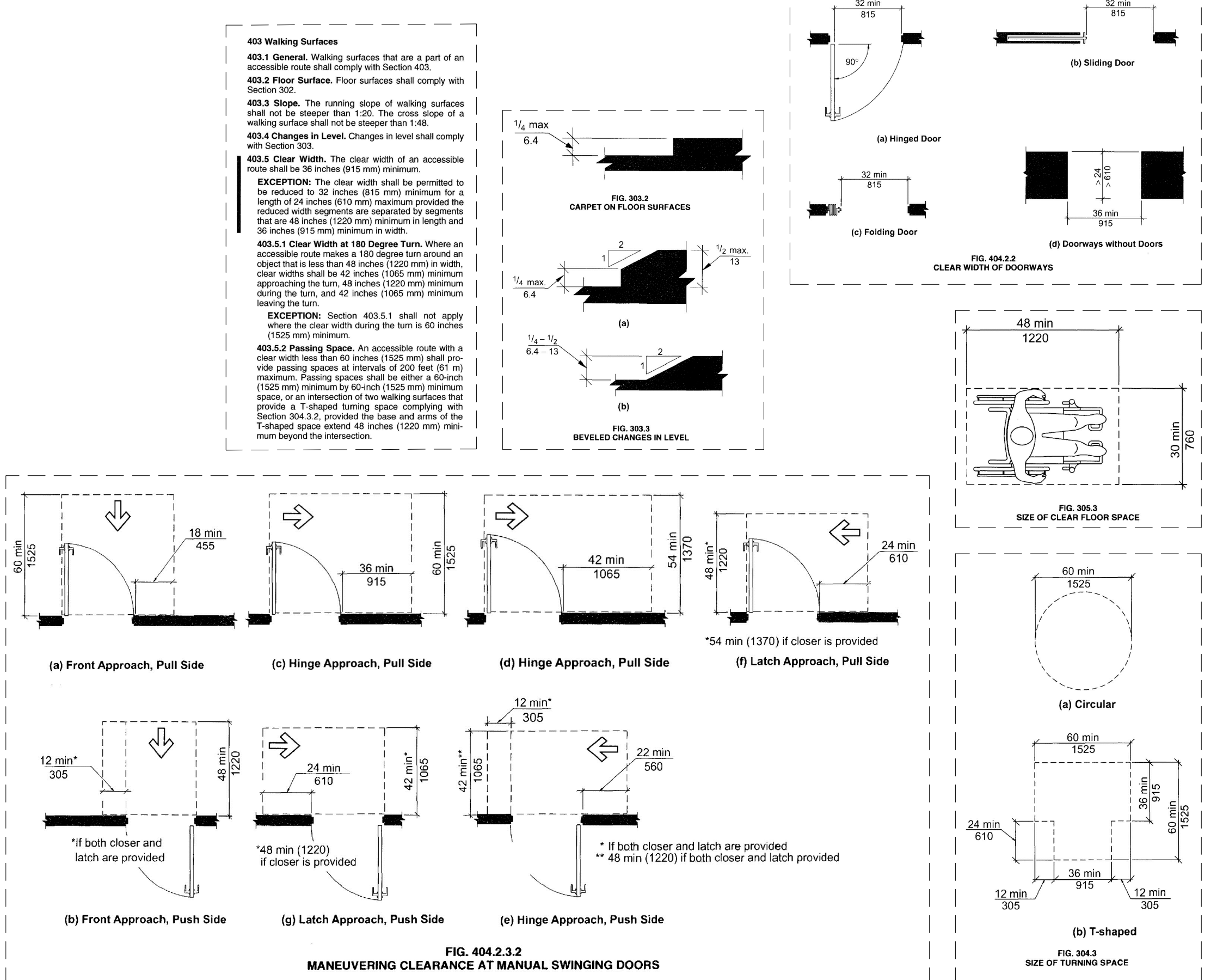
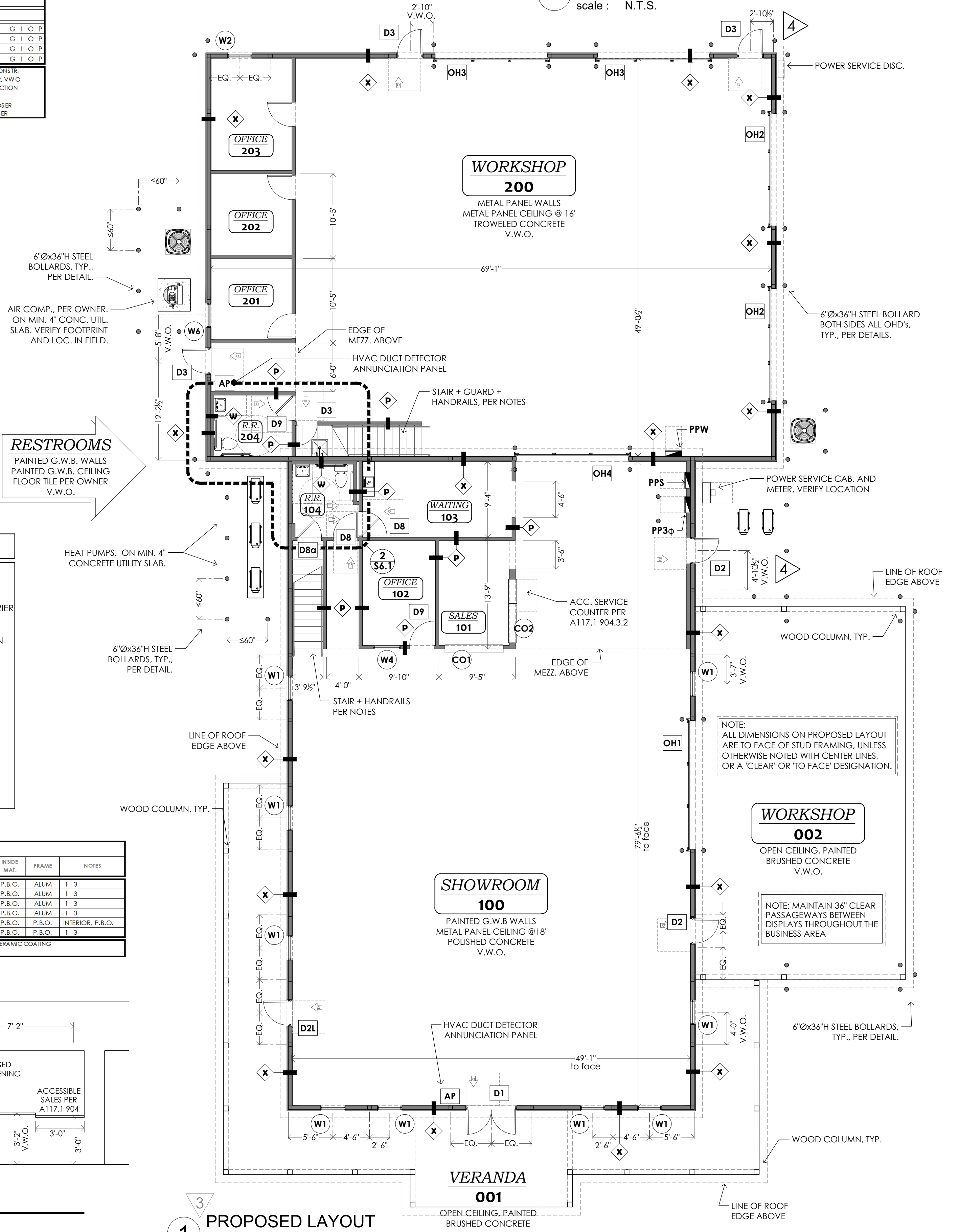
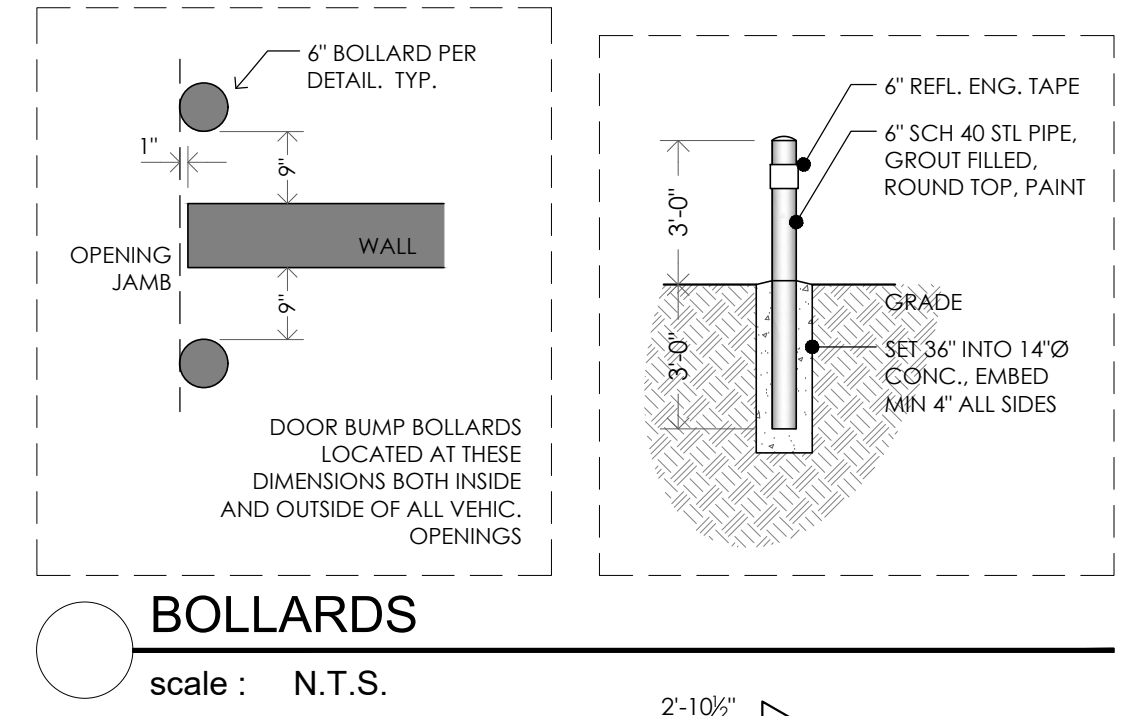
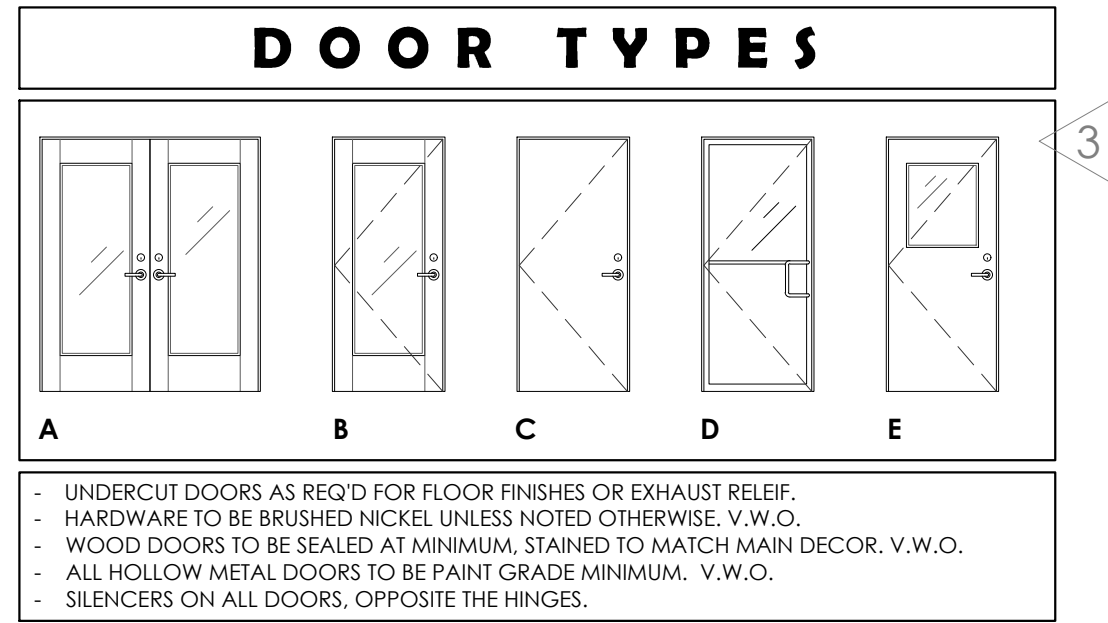

**FDR Engineers, PLLC**  
13200 Strickland Road  
Suite #111 NC 27613  
Raleigh, NC  
www.fdr-eng.com  
(919) 957-5100

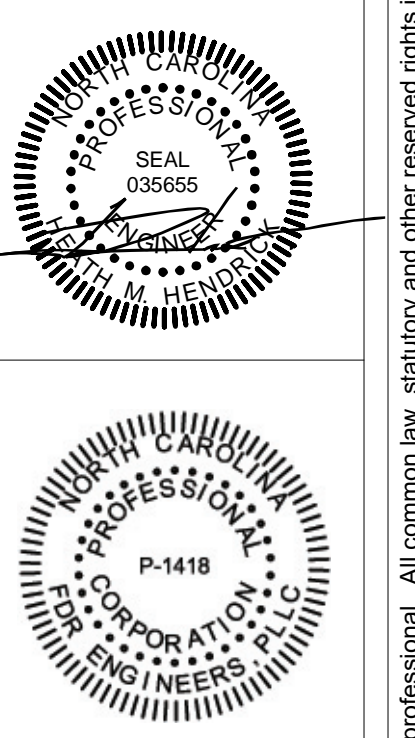

**NoWakerBoats**  
155 Holly Springs Church Road  
Broadway, NC 27505

DESIGNED BY: SMB  
DRAWN BY: SMB  
APPROVED BY: RLP  
PROJECT #: R2408270  
DATE: 2024-10-23

#	Revision	Date
0	for permit	11/25/24
1	BCO comments	01/23/25
2	1ph + HVAC	04/16/25
3	int. off. + mezz.	02/26/26
4	BCO comments	04/02/26

Sheet **S2.3**

Ownership of Instruments of Service: All reports, plans, specifications, computer files, field data, notes and instruments prepared by the design professional as instruments of service shall remain the property of the design professional. All common law, statutory and other reserved rights including the copyright thereof.

# PROJECT GENERAL NOTES

- THE CONTRACT DOCUMENTS INCLUDE THE WORKING DRAWINGS, ANY ADDENDA, MODIFICATIONS, THE CONDITIONS OF THE CONSTRUCTION CONTRACT, AND SPECIFICATIONS AS NOTED ON THE DRAWINGS.
- THE CONTRACT DOCUMENTS ARE INSTRUMENTS OF SERVICE AND SHALL REMAIN THE PROPERTY OF THE ARCHITECT WHETHER THE PROJECT FOR WHICH THEY ARE PREPARED IS EXECUTED OR NOT. THE CONTRACT DOCUMENTS ARE NOT TO BE USED BY THE OWNER FOR OTHER PROJECTS OR EXTENSIONS TO THE PROJECT NOR ARE THEY TO BE MODIFIED IN ANY MANNER WHATSOEVER EXCEPT BY AGREEMENT IN WRITING AND WITH APPROPRIATE COMPENSATION TO THE ARCHITECT.
- THE WORK WILL CONFORM WITH THE REQUIREMENTS OF ALL AGENCIES HAVING JURISDICTION.
- FURNISH MEANS SUPPLY ONLY FOR OTHERS TO PUT IN PLACE.
- PROVIDE MEANS FURNISH AND INSTALL, COMPLETE AND IN PLACE.
- SIMILAR MEANS COMPATIBLE CHARACTERISTICS FOR CONDITIONS NOTED. CONTRACTOR TO VERIFY DIMENSIONS AND ORIENTATION.
- TYPICAL MEANS IDENTICAL FOR CONDITIONS NOTED.
- DO NOT SCALE DRAWINGS. DIMENSIONS GOVERN. VERIFY DIMENSIONS WITH FIELD CONDITIONS. IF DISCREPANCIES ARE DISCOVERED BETWEEN FIELD CONDITIONS AND DRAWINGS OR BETWEEN DRAWINGS, CONTACT ARCHITECT FOR RESOLUTION BEFORE PROCEEDING.
- HORIZONTAL DIMENSIONS INDICATED ARE TO AND FROM FINISHED FACE OF CONSTRUCTION, EXCEPT AS NOTED.
- VERTICAL DIMENSIONS ARE FROM TOP OF FLOOR SLAB OR DECK, EXCEPT WHERE NOTED TO BE ABOVE FINISH FLOOR (A.F.F.).
- DIMENSIONS ARE NOT ADJUSTABLE WITHOUT APPROVAL OF ARCHITECT UNLESS NOTED.
- ALL WORK SHALL BE ERECTED AND INSTALLED PLUMB, LEVEL, SQUARE, AND TRUE AND IN PROPER ALIGNMENT.
- COORDINATE AND PROVIDE BLOCKING/BACKING IN PARTITIONS BEHIND ALL WALL-MOUNTED ITEMS. ALL CONCEALED WOOD TO BE FIRE TREATED.
- MAKE ALL NECESSARY PROVISIONS FOR ITEMS TO BE FURNISHED OR INSTALLED BY TENANT. PROVIDE PROTECTION FOR THESE PROVISIONS UNTIL COMPLETION OF THE PROJECT. GENERAL CONTRACTOR TO COORDINATE N.J.C. ITEMS WITH APPROPRIATE TRADES.
- GENERAL CONTRACTOR SHALL BE RESPONSIBLE FOR CHECKING CONTRACT DOCUMENTS, FIELD CONDITIONS, AND DIMENSIONS FOR ACCURACY AND CONFIRMING THAT WORK IS BUILDABLE AS SHOWN BEFORE PROCEEDING WITH CONSTRUCTION. CLARIFICATIONS REGARDING ANY CONFLICTS SHALL BE ACHIEVED BEFORE RELATED WORK IS STARTED.
- GENERAL CONTRACTOR SHALL VERIFY THAT NO CONFLICTS EXIST IN LOCATIONS OF ANY AND ALL MECHANICAL, TELEPHONE, ELECTRICAL, PLUMBING, AND SPRINKLING EQUIPMENT (TO INCLUDE ALL PIPING, DUCTWORK AND CONDUIT) AND THAT ALL REQUIRED CLEARANCES FOR INSTALLATION AND MAINTENANCE OF ABOVE EQUIPMENT ARE PROVIDED. ELEMENTS TO BE EXPOSED OR CONCEALED SHALL BE DETERMINED AND REVIEWED WITH ARCHITECT IN THE FIELD PRIOR TO CONSTRUCTION PROCEEDING.
- GENERAL CONTRACTOR AND SUB-CONTRACTORS SHALL COORDINATE THE LAYOUT AND EXACT LOCATION OF PARTITIONS, DOORS, ELECTRICAL/TELEPHONE OUTLETS AND LIGHT SWITCHES WITH ARCHITECT IN THE FIELD BEFORE PROCEEDING WITH CONSTRUCTION.
- GENERAL CONTRACTOR SHALL PROVIDE MANUFACTURER'S SPECIFICATIONS INSTALLATION INSTRUCTIONS, SHOP DRAWINGS AND SAMPLES FOR REVIEW AND APPROVAL OF ALL MATERIALS AND METHODS TO BE USED PRIOR TO ORDERING OR PROCEEDING WITH THE WORK.
- EXERCISE EXTREME CARE AND PRECAUTION DURING CONSTRUCTION OF THE WORK TO MINIMIZE DISTURBANCES TO ADJACENT STRUCTURES AND THEIR OCCUPANTS, PROPERTY, PUBLIC THROUGHFARES, ETC. CONTRACTOR SHALL TAKE PRECAUTIONS AND BE RESPONSIBLE FOR THE SAFETY OF ALL BUILDING OCCUPANTS FROM CONSTRUCTION PROCEDURES.
- WITHIN FIVE (5) DAYS FROM CONTRACT DATE, PREPARE AND SUBMIT AN ESTIMATED PROGRESS SCHEDULE FOR THE WORK, WITH SUB SCHEDULES OF RELATED ACTIVITIES SUCH AS DATA/TELEPHONE CABLING AND FURNITURE INSTALLATION.
- ALL WORK SHALL COMPLY WITH APPLICABLE CODES, AMENDMENTS, RULES, REGULATIONS, ORDINANCES, LAWS, ORDERS, APPROVALS, ETC. THAT ARE REQUIRED BY PUBLIC AUTHORITIES, IN THE EVENT OF CONFLICT, THE MOST STRINGENT REQUIREMENTS SHALL GOVERN. REQUIREMENTS INCLUDE, BUT ARE NOT NECESSARILY LIMITED TO, THE CURRENT APPLICABLE EDITIONS OF THE NEW JERSEY STATE BUILDING AND CONSTRUCTION CODES WHICH ARE RECORDED ON THE COVER SHEET OF THIS SET, AS FOUND ON THE WEBSITE OF THE NJ DEPARTMENT OF COMMUNITY AFFAIRS AS OF THE DATE OF COMMENCEMENT FOR THIS PROJECT.
- ABBREVIATIONS USED IN REFERRING TO STANDARDS THAT APPLY TO THE WORK INCLUDE, BUT ARE NOT LIMITED TO THE FOLLOWING:
  - AMERICAN SOCIETY OF TESTING MATERIALS - ASTM
  - AMERICAN WELDING SOCIETY - AWS
  - AMERICAN NATIONAL STANDARDS INSTITUTE - ANSI
  - ALUMINUM ASSOCIATION, INC. - AA
  - NATIONAL ASSOC. OF ARCHIT. METAL MANUF'S - NAAMM
  - NATIONAL WOODWORK MANUF'S ASSOCIATION - NWWA
  - AMERICAN INSTITUTE OF STEEL CONSTRUCTION - AISC
  - AMERICAN CONCRETE INSTITUTE - ACI
  - ARCHITECT, ALUMINUM MANUF'S ASSOCIATION - AAMA
  - CONCRETE REINFORCING STEEL INSTITUTE - CRSI
  - NATIONAL FIRE PROTECTION ASSOCIATION - NFPA
  - AMERICAN WOODWORK INSTITUTE - AWI
- IN THE EVENT OF CONFLICTS BETWEEN DATA, SHOP DRAWINGS AND DATA SHOWN ON THE SPECIFICATIONS, THE SPECIFICATIONS SHALL GOVERN. DIMENSIONS NOTED ON DRAWINGS SHALL TAKE PRECEDENCE OVER SCALED DIMENSIONS. DETAIL DRAWINGS TAKE PRECEDENCE OVER DRAWINGS OF SMALLER SCALE. SHOULD THE CONTRACTOR AT ANY TIME DISCOVER AN ERROR IN A DRAWING OR SPECIFICATION, OR A DISCREPANCY OR VARIATION BETWEEN DIMENSIONS OR DRAWINGS, AND MEASUREMENTS AT SITE, OR LACK OF DIMENSIONS OR OTHER INFORMATION, HE SHALL NOT PROCEED WITH THE AFFECTED WORK UNTIL CLARIFICATION HAS BEEN MADE.
- ONLY NEW ITEMS OF RECENT MANUFACTURE, OF STANDARD QUALITY, FREE FROM DEFECTS WILL BE PERMITTED ON THE WORK. REJECTED ITEMS SHALL BE REMOVED IMMEDIATELY FROM THE WORK AND BE REPLACED WITH ITEMS OF THE QUALITY SPECIFIED. FAILURE TO REMOVE REJECTED ITEMS AND EQUIPMENT SHALL NOT RELIEVE THE CONTRACTOR FROM THE RESPONSIBILITY FOR QUALITY AND CHARACTER OF ITEMS USED NOR FROM ANY OTHER OBLIGATION IMPOSED ON HIM BY THE CONTRACT.
- THE FINISHED WORK SHALL BE FIRM, WELL ANCHORED, IN TRUE ALIGNMENT, PLUMB, LEVEL WITH SMOOTH, CLEAN, UNIFORM APPEARANCE; WITHOUT WAVES, DISTORTIONS, HOLES, MARKS, CRACKS, STAINS OR DISCOLOR. JOINTS SHALL BE CLOSE FITTING, NEAT AND WELL SCRIBED. THE FINISH WORK SHALL HAVE NO EXPOSED, UNSIGHTLY ANCHORS OR FASTENERS AND SHALL NOT PRESENT HAZARDOUS OR UNSAFE CORNERS. ALL WORK SHALL HAVE THE PROVISIONS FOR EXPANSION, CONTRACTION, AND SHRINKAGE AS NECESSARY TO PREVENT CRACKS, BUCKLING, AND WARPING DUE TO TEMPERATURE AND HUMIDITY CONDITIONS.
- ATTACHMENTS, CONNECTIONS, OR FASTENERS OF ANY NATURE ARE TO BE PROPERLY AND PERMANENTLY SECURED IN CONFORMANCE WITH BEST PRACTICE AND THE CONTRACTOR IS RESPONSIBLE FOR IMPROVING THEM ACCORDINGLY AND TO THESE CONDITIONS. THE DRAWINGS SHOW ONLY SPECIAL CONDITIONS TO ASSIST CONTRACTOR; THEY DO NOT ILLUSTRATE EVERY SUCH DETAIL.
- THE CONTRACTOR IS RESPONSIBLE FOR VERIFYING THE DIMENSIONS AND ELEVATIONS AT THE SITE. THE CONTRACTOR AND SUB-CONTRACTORS SHALL COORDINATE THE LAYOUT AND EXACT LOCATIONS OF ALL PARTITIONING, DOORS, ELECTRICAL/TELEPHONE OUTLETS, LIGHT SWITCHES AND THERMOSTATS WITH THE OWNER/AGENT IN THE FIELD BEFORE PROCEEDING WITH CONSTRUCTION.
- NO WORK DEFECTIVE IN CONSTRUCTION OR QUALITY OR DEFICIENT IN ANY REQUIREMENTS OF DRAWINGS AND SPECIFICATIONS WILL BE ACCEPTABLE IN CONSEQUENCE OF OWNER'S OR ARCHITECT'S FAILURE TO DISCOVER OR TO POINT OUT DEFECTS OR DEFICIENCIES DURING CONSTRUCTION; NOR WILL PRESENCE OF INSPECTORS ON WORK SITE RELIEVE CONTRACTOR FROM RESPONSIBILITY FOR SECURING QUALITY AND PROGRESS OF WORK AS REQUIRED BY CONTRACT. DEFECTIVE WORK REVEALED WITHIN REQUIRED TIME GUARANTEES SHALL BE REPLACED BY WORK CONFORMING WITH INTENT OF CONTRACT. NO PAYMENT, WHETHER PARTIAL OR FINAL, SHALL BE CONSIDERED AS AN ACCEPTANCE OF DEFECTIVE WORK OR IMPROPER MATERIALS.
- MATERIALS AND WORKMANSHIP SPECIFIED BY REFERENCE TO NUMBER, SYMBOL, TITLE OF SPECIFICATION SUCH AS COMMERCIAL STANDARDS, FEDERAL SPECIFICATIONS, TRADE ASSOCIATION STANDARD OR OTHER SIMILAR STANDARDS, SHALL COMPLY WITH REQUIREMENTS IN THE LATEST EDITION OR REVISION THEREOF AND WITH ANY AMENDMENT OR SUPPLEMENT THERETO IN EFFECT ON DATE OF ORIGIN OF THIS PROJECT'S CONTRACT DOCUMENTS. SUCH STANDARDS, EXCEPT AS MODIFIED HEREIN, SHALL HAVE FULL FORCE EFFECTS AS THOUGH PRINTED IN CONTRACT DOCUMENTS.
- CONTRACTOR SHALL WAIVE "COMMON PRACTICE" AND "COMMON USAGE" AS CONSTRUCTION CRITERIA WHEREVER DETAILS AND CONTRACT DOCUMENTS OR GOVERNING CODES, ORDINANCES, ETC. REQUIRE GREATER QUANTITY OR BETTER QUALITY THAN COMMON PRACTICE OR COMMON USAGE.
- CONTRACTOR SHALL ORDER AND SCHEDULE DELIVERY OF MATERIALS IN AMPLE TIME TO AVOID DELAYS IN CONSTRUCTION. IF AN ITEM IS FOUND TO BE UNAVAILABLE, CONTRACTOR SHALL NOTIFY THE OWNER IMMEDIATELY TO ALLOW THE OWNER A REASONABLE AMOUNT OF TIME TO SELECT A SUITABLE SUBSTITUTION.
- IF AT ANY TIME BEFORE COMMENCEMENT OF WORK, OR DURING PROGRESS THEREOF, CONTRACTOR'S METHODS, EQUIPMENT, OR APPLIANCES ARE INAPPROPRIATE FOR SECURING QUALITY OF WORK OR RATE OF PROGRESS INTENDED BY CONTRACT DOCUMENTS, OWNER MAY ORDER CONTRACTOR TO IMPROVE THEIR QUALITY OR INCREASE EFFICIENCY. THIS WILL NOT RELIEVE CONTRACTOR OF HIS SURETIES FROM THEIR OBLIGATIONS TO SECURE QUALITY OF WORK AND RATE OF PROGRESS SPECIFIED IN CONTRACT.
- WITH REFERENCE TO CEILINGS, CONTRACTOR SHALL COORDINATE WITH ALL TRADES INVOLVED TO INSURE THAT CONFLICTS DO NOT OCCUR BETWEEN LIGHT FIXTURES, DUCTWORK, DIFFUSERS, ETC., AND THAT THE CEILING HEIGHTS INDICATED ON DRAWINGS ARE ACHIEVED.
- REFERENCE TO MARKS, BRANDS, ETC., IS TO ESTABLISH THE TYPE AND QUALITY DESIRED; SUBSTITUTIONS OF ACCEPTABLE EQUIVALENTS WILL BE PERMITTED WITH OWNER'S APPROVAL SPECIFICALLY NOTED OTHERWISE IN THE CONTRACT DOCUMENTS.
- CONTRACTOR SHALL APPLY FOR, PAY FOR, AND OBTAIN ALL REQUIRED PERMITS FOR CONSTRUCTION AND OCCUPANCY.
- PROVIDE SHOP AND/OR SUBMITTALS FOR THE FOLLOWING ITEMS AT THE OWNERS REQUEST:
  - MILLWORK, CASEWORK, AND HARDWARE
  - FLOOR FINISHES
  - DOORS, DOOR HARDWARE + HOLLOW METAL FRAMES
  - LIGHTING, EXIT SIGNAGE, AND EMERGENCY DEVICES
  - FINISH CARPENTRY
  - ACOUSTICAL CEILING TILE AND GRID
  - ALUMINUM FRAMES
  - ELECTRICAL DEVICES
  - GLAZING
  - WALL FINISHES
  - MECHANICAL EQUIPMENT
- PRIOR TO SUBMITTING A QUOTATION FOR THIS WORK, THE CONTRACTOR SHALL REVIEW THESE DRAWINGS AND SPECIFICATIONS AND SHALL VISIT THE SITE TO FAMILIARIZE HIMSELF (THEMSELVES) WITH EXISTING CONDITIONS AND LIMITATIONS. THE CONTRACTOR SHALL NOTIFY THE OWNER AS SOON AS POSSIBLE OF ANY NOTABLE DISCREPANCIES.
- WORK SHALL BE PERFORMED IN STRICT ACCORDANCE WITH APPLICABLE FIRE, HEALTH, SAFETY AND BUILDING CODES OF THE STATE AND LOCAL JURISDICTION IN WHICH THE PREMISES ARE SITUATED, WORKING CONDITIONS TO COMPLY WITH FEDERAL OCCUPATIONAL SAFETY AND HEALTH ACT GUIDELINES. CONTRACTORS SHALL REMOVE OR REPAIR ALL CONDITIONS NOT IN ACCORDANCE WITH STATE AND LOCAL CODES.
- THE CONTRACTOR SHALL BE FREE OF DEFECTS FOR A PERIOD OF ONE (1) YEAR FROM DATE OF SUBSTANTIAL COMPLETION. ALL SUCH DEFECTS SHALL BE CORRECTED BY THIS CONTRACTOR (S) AT NO EXPENSE TO THE OWNER.
- THE CONTRACTOR SHALL PROVIDE ALL LABOR, GOODS AND SERVICES REQUIRED TO COMPLETE THE WORK IN GOOD ORDER AND ON TIME, IN ACCORDANCE WITH THE CONSTRUCTION SCHEDULE SUBMITTED BEFORE COMMENCING WORK.
- GENERAL CONTRACTOR SHALL BE RESPONSIBLE FOR DEBRIS REMOVAL. DO NOT ALLOW DEBRIS TO ACCUMULATE. PROVIDE ADEQUATE DUST AND NOISE BARRIERS. ALL AREAS SHALL BE LEFT BROOM CLEAN DAILY. WASH AND CLEAN ALL WORK AFFECTED BY CONSTRUCTION AT COMPLETION OF PROJECT. PROVIDE WEATHER BARRIERS AS REQUIRED. ALL COMPLETED OR ADJACENT WORK SHALL BE PROTECTED. ALL RUBBISH AND DEBRIS REMOVED ON A DAILY BASIS, AND THE PREMISES DELIVERED TO THE LANDLORD, READY FOR TENANT. CLEAN ALL EXPOSED SURFACES, INCLUDING GLAZING. CONTRACTOR SHALL BE RESPONSIBLE FOR ALL TRASH REMOVAL. COORDINATE WITH LANDLORD FOR SOURCE OF WATER DURING CONSTRUCTION.
- CONTRACTOR SHALL BE RESPONSIBLE FOR KEYING ALL REQUIRED LOCK SETS AND COORDINATING WITH OWNER TO ENSURE THAT CYLINDERS ARE KEED TO BUILDING MASTER KEY SYSTEM AND THAT SUFFICIENT NUMBER OF KEYS ARE SUPPLIED AT TIME OF SUBSTANTIAL COMPLETION.
- THE GENERAL CONTRACTOR SHALL BE RESPONSIBLE FOR ADEQUATE FIRE EXTINGUISHERS IN HIS WORK SPACE TO COMPLY WITH ALL FIRE REGULATIONS THROUGHOUT THE DURATION OF CONSTRUCTION. CONTRACTORS SHALL COMPLY WITH ALL FEDERAL AND LOCAL SAFETY REGULATIONS IN THE EXECUTION OF THEIR WORK.
- THESE DRAWINGS ARE TO BE USED FOR THE PROJECT AND SITE SPECIFICALLY IDENTIFIED HEREIN AND MAY NOT BE USED ON ANY OTHER PROJECT.
- FIELD INVESTIGATIONS SHALL BE MADE TO THE EXTENT NECESSARY TO INSURE NO BUILDING OR ADJACENT TENANT SERVICES ARE DISTURBED OR INTERRUPTED WITHOUT PRIOR PERMISSION OF THE OWNER.
- THE EXIT AND EMERGENCY LIGHTS SHOWN ARE FOR GUIDANCE. THE CONTRACTOR SHALL VERIFY/COORDINATE WITH LOCAL INSPECTOR FOR EXACT QUANTITY AND LOCATIONS.
- CONTRACTOR SHALL INSPECT ALL SUBSTRATES PRIOR TO INSTALLING FINISH MATERIALS. INSTALLATION OF FINISH MATERIALS BY SUBCONTRACTORS INDICATES ACCEPTANCE OF SUBSTRATE AND THAT THE SUBSTRATE IS ACCEPTABLE FOR THAT SPECIFIC FINISH.

## 2018 APPENDIX B BUILDING CODE SUMMARY FOR ALL COMMERCIAL PROJECTS (EXCEPT 1 AND 2-FAMILY DWELLINGS AND TOWNHOUSES)

Name of Project: **NC WAKE BOATS**  
 Address: **143 HOLLY SPRINGS CHURCH ROAD** Zip Code: **27505**  
 Proposed Use: **SHOWROOM & WORKSHOP**  
 Owner/Authorized Agent: **DAVID TURNER** Phone # (910) 928-1104 Email: **david@ncwakeboats.com**  
 Owned By:  City / County  Private  State  
 Code Enforcement Jurisdiction:  City  County **MOORE**  State

LEAD DESIGN PROFESSIONAL	ROBERT PENNINGTON, ENGINEER
DESIGNER	FIRM NAME LICENSE # TELEPHONE #
Architectural	FDR ENGINEERS Robert Pennington 025045 (910) 520-0278
Civil	Arnold Land Design James David Arnold 036865 (910) 430-2552
Electrical	FDR ENGINEERS Robert Pennington 025045 (910) 520-0278
Fire Alarm	BY OTHERS <b>defelmed</b>
Plumbing	FDR ENGINEERS Robert Pennington 025045 (910) 520-0278
Mechanical	FDR ENGINEERS Robert Pennington 025045 (910) 520-0278
Sprinkler-Standpipe	FDR ENGINEERS Heath M Hendrick 035655 (910) 427-0501
Structural Foundation	
Retaining Walls-5' High	
Other	

2018 NC BUILDING CODE FOR:  New Construction  Addition  Upfit  
 2018 EXIST. BUILDING CODE FOR:  Reconstruction  Alteration  Repair  Renovation  
 CONSTRUCTED: (date) \_\_\_\_\_ CURRENT USE(S) (Ch. 3): \_\_\_\_\_  
 RENOVATED: (date) \_\_\_\_\_ PROPOSED USE(S) (Ch. 3): **B & S-1**

**BUILDING DATA:**

Construction Type:  I-A  I-B  II-A  II-B  III-A  III-B  IV  V-A  V-B

Mixed Construction:  No  Yes Types \_\_\_\_\_

Sprinklers:  No  Partial  Yes  NFPA 13  NFPA 13R  NFPA 13D

Standpipes:  No  Yes Class  I  II  III  Wet  Dry

Fire District:  No  Yes Flood Hazard Area:  No  Yes

Building Height: **28.4'** Feet **1** Number of Stories

Special Inspections: **none**

Gross Building Area:

FLOOR	EXIST. (GR SQ FT)	NEW (GR SQ FT)	SUB-TOTAL
1st Floor		11,962 sf	11,962 sf
TOTAL		11,962 sf	11,962 sf

### ALLOWABLE AREA

Primary Occupancy:  Business  Educational  Mercantile  Storage  S-1 Moderate  S-2 Low  High-piled

Mixed Occupancy:  No  Yes Separation: **NA Hr.** Exception:  Non-Separated Use (508.3)

The required type of construction for the building shall be determined by applying the height and area limitations for each of the applicable occupancies to the entire building. The most restrictive type of construction, so determined, shall apply to the entire building.

Actual Area of Occupancy A	Actual Area of Occupancy B	Allowable Area of Occupancy A	Allowable Area of Occupancy B	Sum	Limit
		11,962	11,962	0.831	≤ 14,400

STORY NO.	DESCRIPTION AND USE	(A) BLDG AREA PER STORY (ACTUAL)	(B) TABLE 503.5 AREA	(C) AREA FOR FRONTAGE INCREASE 1	(D) AREA FOR SPRINKLER INCREASE 2	(E) ALLOWABLE AREA OR 3 UNLIMITED	(F) MAXIMUM BLDG AREA 4
1	B... SHOWROOM	6,362	9,000	+60%	NA	NA	14,400
1	S-1... WORKSHOP	5,600	9,000	+60%	NA	NA	14,400

- Frontage area increases from Section 506.2 are computed thus:
  - Perimeter which fronts a public way or open space having 20 feet minimum width = **536' (P)**
  - Total Building Perimeter = **536' (P)**
  - Ratio (F/P) = **1 (F/P)**
  - W = Minimum width of public way = **29.6' (W)**
$$\frac{[(L \times W) + (L_2 \times W_2) + (L_3 \times W_3)]}{F} = F$$

$$\frac{[(24 \times 30) + (29 \times 25) + (30 \times 498)]}{536} = 29.6'$$
- Percent of frontage increase  $I_f = 100 \left[ \frac{F}{P} - 0.25 \right] \times W/30 = \mathbf{74\%}$ 

$$100 \left[ \frac{1}{536/536} - 0.25 \right] \times 29.6 / 30 = 74.12\%$$

### ALLOWABLE HEIGHT

Building Height in Feet	ALLOWABLE (TABLE 503)	SHOWN ON PLANS	CODE REFERENCE
Building Height in Stories	<b>40</b>	<b>28</b>	
	<b>(B) 2 (S-1) 1</b>		

- Provide code reference if the "Shown on Plans" quantity is not based on Table 504.3 or 504.4.

### FIRE PROTECTION REQUIREMENTS

Life Safety Plan Sheet #, if Provided: **CS**

BUILDING ELEMENT	FIRE SEPARATION DISTANCE (FEET)	RATING PROVIDED (W/ REDUCTIONS)	DETAIL # AND SHEET #	DESIGN # FOR RATED ASSEMBLY	SHEET # FOR RATED PENETRATION	SHEET # FOR RATED JOINTS
Structural frame, including columns, girders, and trusses	NA	NA				
Bearing walls	NA	NA				
Exterior	NA	NA				
North	NA	NA				
East	NA	NA				
West (602, F.S.D.)	10'5x<30'	0hrs				
South	NA	NA				
Interior	NA	NA				
Nonbearing walls and partitions	NA	NA				
Exterior Walls	NA	NA				
North	NA	NA				
East	NA	NA				
West	NA	NA				
South	NA	NA				
Interior walls and partitions	NA	NA				
Floor construction including supporting beams and joists	NA	NA				
Floor-Ceiling Assembly	NA	NA				
Columns Supporting Floors	NA	NA				
Roof construction including supporting beams and joists	NA	NA				
Floor-Ceiling Assembly	NA	NA				
Columns Supporting Roof	NA	NA				
Shaft Enclosures - Exit	NA	NA				
Shaft Enclosures - Others	NA	NA				
Corridor Separation	NA	NA				
Occupancy Separation	NA	NA				
Party/Fire Wall Separation	NA	NA				
Smoke Barrier Separation	NA	NA				
Tenant Separation	NA	NA				
Incidental Use Separation	NA	NA				

### LIFE SAFETY SYSTEM REQUIREMENTS

- Emergency Lighting:  No  Yes  
 Exit Signs:  No  Yes  
 Fire Alarm:  No  Yes  
 Smoke Detection Systems:  No  Yes  Partial **AHU RA Duct Detectors**  
 Carbon Monoxide Detection:  No  Yes

### LIFE SAFETY PLAN REQUIREMENTS

- Life Safety Plan Sheet #: **CS**
- Fire and/or smoke rated wall locations (Chapter 7)
  - Assumed and real property line locations (if not on the site plan)
  - Exterior wall opening area with respect to distance to assumed property lines (705.8)
  - Occupancy Use for each area as it relates to occupant load calculation (Table 1004.1.2)
  - Occupant loads for each area
  - Exit access travel distances (1017)
  - Clear end lengths (1020.4)
  - Clear exit widths for each exit door
  - Max. calculated occ. load capacity each exit door can accommodate based on egress width (1005.3)
  - Actual occupant load for each exit door
  - A separate schematic plan indicating where fire rated floor/ceiling and/or roof structure is provided for purposes of occupancy separation
  - Location of doors with panic hardware (1010.1.10)
  - Location of doors with delayed egress locks and the amount of delay (1010.1.9.7)
  - Location of doors with electromagnetic egress locks (1010.1.9.9)
  - Location of doors equipped with hold-open devices
  - Location of emergency escape windows (1030)
  - The square footage of each fire area (302)
  - The square footage of each smoke compartment for Occupancy Classification 1-2 (407.5)
  - Note any code exceptions or table notes that may have been utilized regarding the items above

### EXIT REQUIREMENTS

FLOOR, ROOM OR SPACE DESIGNATION	MINIMUM NUMBER OF EXITS	TRAVEL DISTANCE	ARRANGEMENT MEANS OF EGRESS 1	ACTUAL MEANS OF EGRESS 2
SHOWROOM	1	3	200'	93'
WORKSHOP	1	3	200'	48'

- Corridor dead ends (Section 1020.4)
- Single exits (Table 1006.3.1). Spaces with one egress (Table 1006.2.1)
- Common Path of Travel (Section 1006.2.1)

### EXIT WIDTH

USE GROUP OR SPACE DESCRIPTION	(a) AREA 1 sq. ft.	(b) AREA 1 PER OCCUPANT (TABLE 1004.1.2)	(c) CALCULATED OCCUPANT LOAD	(d) EGRESS WIDTH PER OCCUPANT (SECTION 1005.3) (TABLE 1005.3.1) (6'-0" MIN.)	(e) EXIT WIDTH (a) / (c)	(f) ACTUAL WIDTH SHOWN ON PLANS
SHOWROOM	REFER TO SCHEDULE	14	0.3	0.2	NA	0.42'
WORKSHOP	SCHEDULE	14	0.3	0.2	NA	0.42'

### BONDING OF METAL VENEERS

ELECTRICAL CONTRACTOR SHALL PROVIDE ADEQUATE BONDING OF THE INSTALLED METAL VENEER PANELS, PURSUANT TO SECTION 250 OF THE 2020 NFPA-70 (NEC) WITH NORTH CAROLINA AMENDMENTS AND TO THE SATISFACTION OF THE LOCAL ELECTRICAL CODE OFFICIAL/INSPECTOR HAVING AUTHORITY.

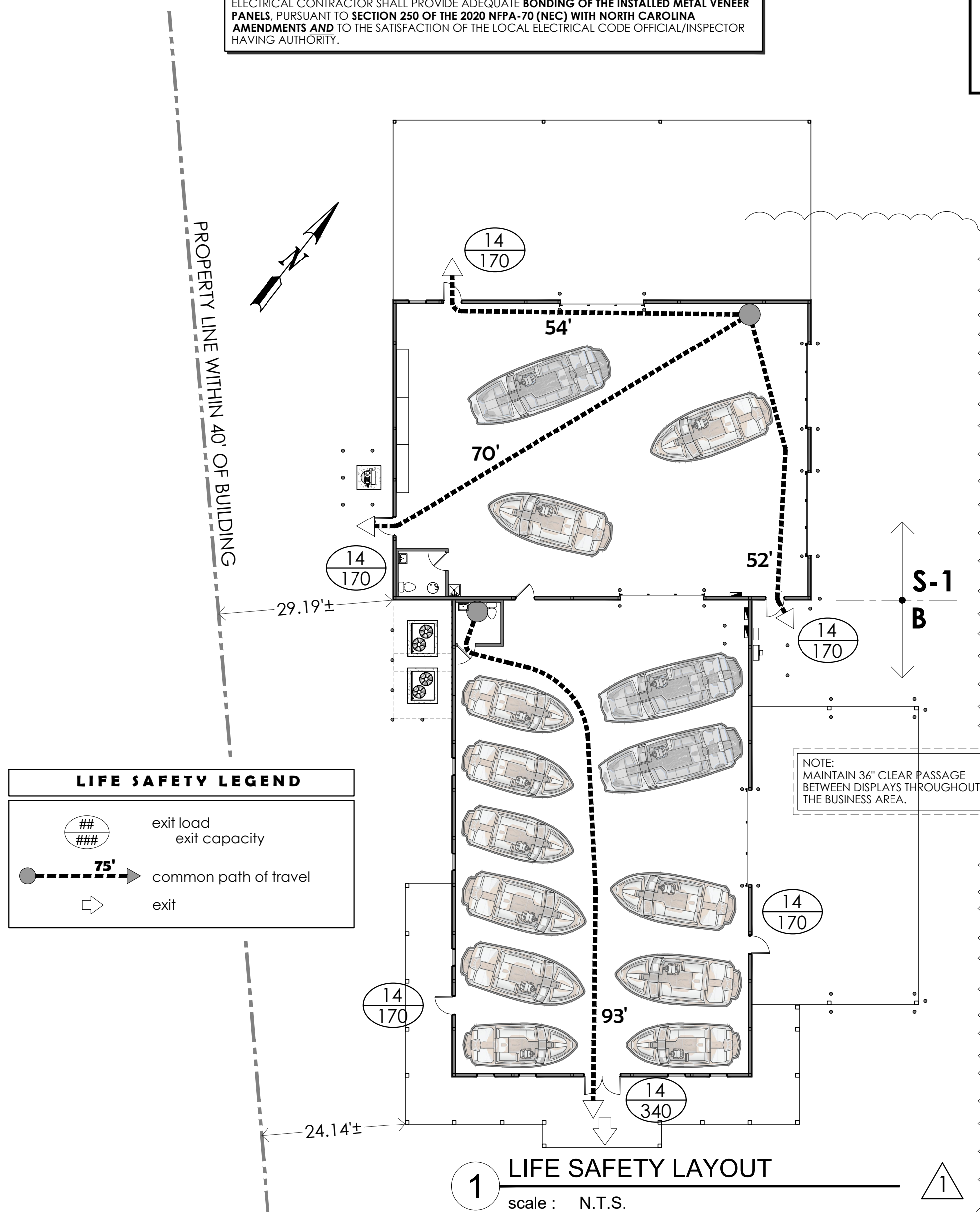

### LIFE SAFETY LAYOUT

scale: N.T.S.

# NC WakeBoats

## Broadway, NC

### INDEX

STRUCTURAL	DEFERRED - D	NO CHANGES - O	CHANGES - C
<b>CS</b> CODE, PROJECT DATA + LIFE SAFETY	RLP	●	●
<b>S1.1</b> STRUCTURAL NOTES	HMH	●	○
<b>S2.1</b> FOUNDATION	HMH	●	○
<b>S2.2</b> ROOF FRAMING	HMH	●	○
<b>S2.3</b> GRADE LAYOUT + SCHEDULES	RLP	●	●
<b>S2.4</b> R.C.F. + ROOF LAYOUTS	RLP	●	○
<b>S4.1</b> SECTIONS	HMH	●	○
<b>S4.1</b> DETAILS	HMH	●	○
<b>S5.1</b> ELEVATIONS	RLP	●	○
<b>TRUSS</b> BRUSSES	BY OTHERS	D	D
<b>MECHANICAL</b>	RLP	●	●
<b>M1.1</b> LAYOUT, NOTES, SCHEDULES + DETAILS	RLP	●	○
<b>PLUMBING</b>	RLP	●	○
<b>PL1.1</b> F.W. SUPPLY, SAN, NOTES, SCHEDULES + DETAILS	RLP	●	○
<b>ELECTRICAL</b>	RLP	●	○
<b>E0.1</b> NOTES, DETAILS, RISER + SCHEDULES	RLP	●	○
<b>E1.1</b> LAYOUTS, NOTES + SCHEDULES	RLP	●	○

### CONTACTS

<b>David Turner</b> <b>NC WakeBoats</b> 143 Holly Springs Church Road Broadway, NC 27505 <a href="mailto:david@ncwakeboats.com">david@ncwakeboats.com</a>	<b>OWNER</b>	(919) 928-1104
<b>Heath M. Hendrick</b> <b>FDR ENGINEERS</b> 13200 Strickland Road Ste. 114 Raleigh, NC <a href="mailto:hendrick@fdr-eng.com">hendrick@fdr-eng.com</a>	<b>STRUCTURAL ENGINEER</b>	(919) 427-0501
<b>Robert L. Pennington</b> <b>FDR ENGINEERS</b> 7429 Malloy Road Wilmington, NC 28411 <a href="mailto:roberlp@fdr-eng.com">roberlp@fdr-eng.com</a>	<b>APPX B &amp; MPE ENGINEER</b>	(910) 520-0278
<b>Shawn Breen</b> <a href="mailto:shawn.m.breen@gmail.com">shawn.m.breen@gmail.com</a>	<b>APPX B &amp; MPE PM</b>	(860) 387-3017

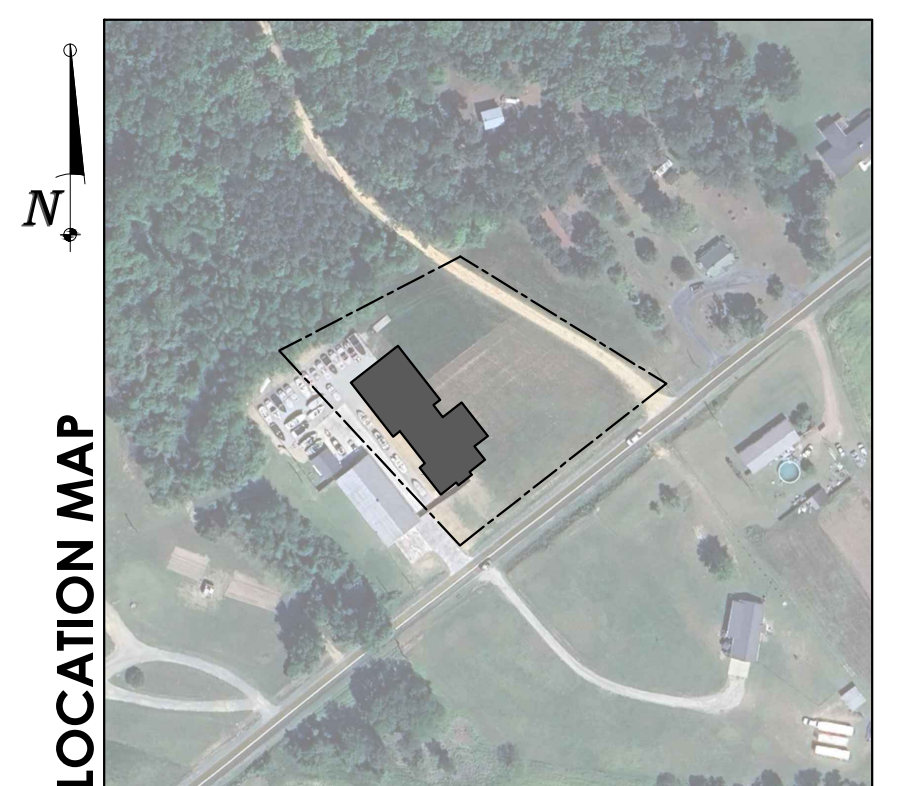
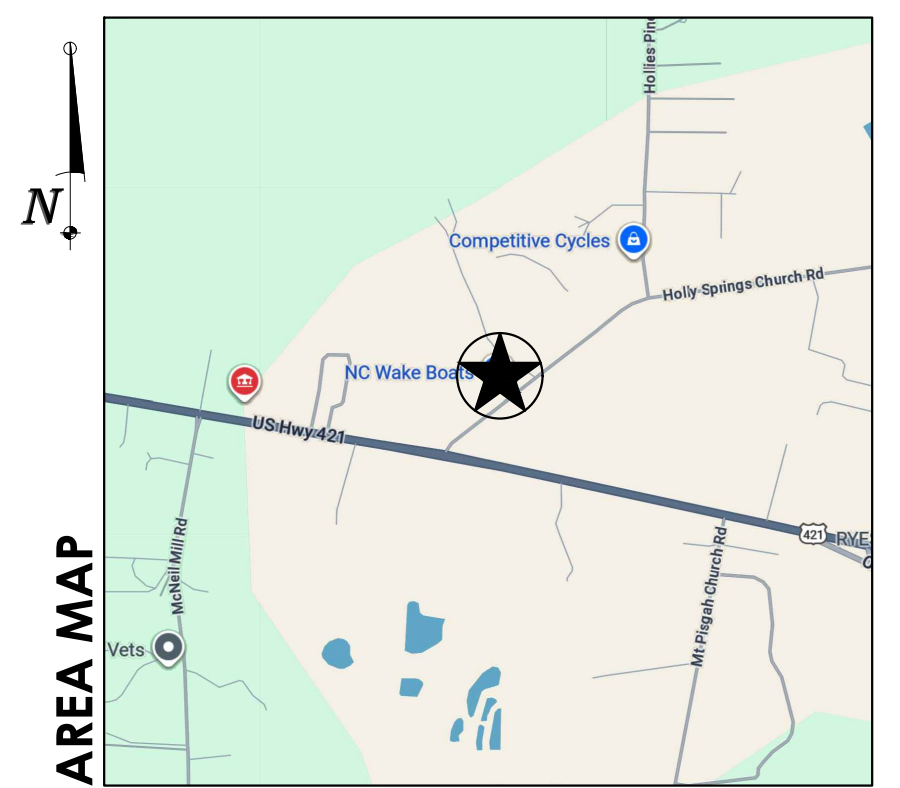

**FDR Engineers, PLLC**  
 13200 Strickland Road  
 Suite # 114  
 Raleigh, NC 27613  
[www.fdr-eng.com](http://www.fdr-eng.com)  
 (919) 957-5100

**FDR ENGINEERS**

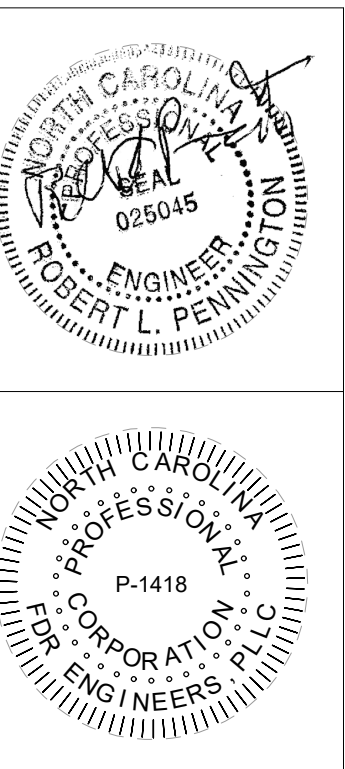

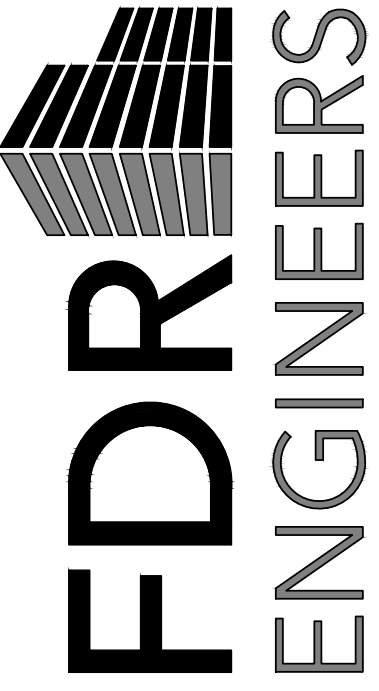

13200 STRICKLAND ROAD  
SUITE 114, BOX 332  
RALEIGH, NC 27613  
p. 919.957.5100 - f. 919.957.5101  
www.fdr-eng.com  
jfejfar@fdr-eng.com



WAKEBOARD DEALERSHIP

SANFORD, NC

Project Name

GENERAL NOTES

Sheet Title

DESIGNED BY: AJI

DRAWN BY: AJI

APPROVED BY: HMM

PROJECT #: 24-067

DATE: 11/27/2024

No.	Revision	Date

Sheet

S1.1

FOR PERMIT ONLY

**STRUCTURAL ABBREVIATIONS.**

ABBREV.	DEFINITION
AB	ANCHOR BOLTS
ADJ	ADJACENT
AFF	ABOVE FINISHED FLOOR
ALT	ALTERNATE
ARCH	ARCHITECT
BCX	BOTTOM CHORD EXTENSION
BF	BELOW FINISHED FLOOR
BOT	BOTTOM
B.O.xx	BOTTOM OF xx
BOC	BOTTOM OF STEEL
BLDG	BUILDING
BU	BEAM
BRG	BEARING
CANT	CANTILEVER
CH	CHANGELINE
CJ	CONTROL JOINT
CLR	CLEAR
CMU	CONCRETE MASONRY UNIT
COL	COLUMN
CONC	CONCRETE
CONST	CONSTRUCTION
CONT	CONTINUOUS
CP	COMPLETE PENETRATION
D	DECK
DBA	DEFORMED BAR ANCHOR
DBL	DOUBLE
DEG	DEGREE
DET.DTL	DETAIL
DI	DIAMETER
DIAG	DIAGONAL
DM	DIMENSION
DK	DECK
DN	DOWN
DWGS	DRAWINGS
DWL	DOWEL
EA	EACH
EF	EACH FACE
EJ	EXPANSION JOINT
EL ELEV	ELEVATION
EMBED	EMBEDDED / EMBEDMENT
ENGR	ENGINEER
EO	EDGE OF DECK
EQ	EQUAL
EQ	EQUAL
EQU	EQUIPMENT
EW	EACH WAY
EXIST	EXISTING
EXP	EXPANSION
EXT	EXTERIOR
FIN	FINISH
FLR	FLOOR
FLD	FLOOR DRAIN
FND	FOUNDATION
FR	FACE OF MASONRY
FS	FACE OF WALL
FOW	FOOTING STEP
FTG	FIELD VERIFY
FV	GAUGE
GA	GALVANIZED
GB	GRADE BEAM
GH	HIGH
HORZ	HORIZONTAL
HSE	HIGH STRENGTH EPOXY
HSS	HOLLOW STRUCTURAL SECTION
IF	INSIDE FACE
INT	INTERIOR
JOINT	JOINT
K	KIPS = 1000 LBS
KB	KNEE BRACE
KSI	KIPS PER SQUARE INCH
KLF	KIPS PER LINEAR FOOT
LBS	POUNDS
LH	LONG LEG HORIZONTAL
LLV	LONG LEG VERTICAL
LOC	LOCATION
LSL	LAMINATED STRAND LUMBER
LVL	LUMBER VENEER LUMBER
LW	LONG WAY
LWC	LIGHT WEIGHT CONCRETE
MAS	MASONRY
MAX	MAXIMUM
MC	MOMENT CONNECTION
MECH	MECHANICAL
MFR	MANUFACTURER
MID	MIDDLE
MIN	MINIMUM
MISC	MISCELLANEOUS
MP	MASONRY PILASTER
MTL	METAL
No / #	NUMBER
NOM	NOMINAL
NTS	NOT TO SCALE
NWC	NORMAL WEIGHT CONCRETE
OC	ON CENTER
OF	OPPOSITE HAND
OPNG	OPENING
PAF	POWDER ACTUATED FASTENER
PC	PRECAST
PE	PER-ENGINEERED
PL	PLATE
PLF	POUNDS PER LINEAR FOOT
PSF	POUNDS PER SQUARE FOOT
PSI	POUNDS PER SQUARE INCH
PSL	PARALLEL STRAND LUMBER
PT	PRESSURE TREATED
R	RADIUS
REF	REFERENCE
REIN	REINFORCEMENT
REQD	REQUIRED
REV	REVISION
SCD	SLIP CRITICAL
SCHD	SCHEDULE
SIS	SELF DRILLING SCREW
SECT	SECTION
SHT	SHEET
SIM	SIMILAR
SL	SLAB
SOG	SLAB ON GRADE
SP	SPECIAL JOIST
SPC	SPECIFICATION
SQ	SQUARE
STD	STANDARD
STL	STEEL
SW	SHORT WAY
SYM	SYMMETRICAL
TCX	TOP CHORD EXTENSION
TAB	TOP AND BOTTOM
TOC	TOP OF CONCRETE
TOS	TOP OF STEEL
TOW	TOP OF WALL
T.O.xx	TOP OF xx
THK	THICKNESS
TJ	TIE JOIST
TYP	TYPICAL
UNO	UNLESS NOTED OTHERWISE
VERT	VERTICAL
VIF	VERIFY IN FIELD
WVF	WELDED WIRE FABRIC
WWM	WELDED WIRE MESH

**WOOD:**

- STRUCTURAL & WOOD COMPONENTS HAVE BEEN DESIGNED AS SOUTHERN YELLOW PINE (SPY) OR HEM-FIR (HF) NO. 2 OR BETTER AND SHALL HAVE THE FOLLOWING MINIMUM ALLOWABLE FIBER STRESSES AND PROPERTIES:  
MODULUS OF ELASTICITY (E) 1,300,000 PSI  
BENDING (Fb) 850 PSI  
SHEAR (Fv) 75 PSI
- TREATED IN CONTACT WITH CONCRETE OR MASONRY SHALL BE PROTECTED OR PRESURE TREATED IN ACCORDANCE WITH AITC-109.
- MEMBER SIZES SHOWN ARE NOMINAL UNLESS NOTED OTHERWISE.
- BOLTS IN WOOD ARE MACHINE BOLTS, UNLESS OTHERWISE NOTED. MACHINE BOLTS SHALL HAVE A SHANK DIAMETER WITHIN 1/64" OF THAT SPECIFIED. BOLTS ARE ASTM 307 STEEL. BOLT HOLES IN WOOD SHALL BE 1/32" OVERSIZE. WHERE STEEL IS CONNECTED TO WOOD, HOLES IN STEEL SHALL BE 1/16" OVERSIZE. PROVIDE STANDARD CUT WASHERS UNDER HEAD AND NUT WHERE BEARING IS AGAINST WOOD. WHERE STEEL SIDE PLATES ARE USED FOR CONNECTION, THE PLATE SHALL BE USED AS A TEMPLATE.
- ALL WOOD ELEMENTS SHALL BE ATTACHED PER THE FASTENING SCHEDULE OF THE 2012 NCSBC (TABLE 2304.9.1) UNLESS OTHERWISE NOTED.
- SEE ARCHITECTURAL DRAWINGS FOR WEATHER PROTECTION OF ALL EXPOSED WOOD MEMBERS.

**WOOD SHEATHING:**

- PLYWOOD ROOF, FLOOR AND WALL SHEATHING ARE DESIGNED AS DIAPHRAGMS AND SHALL COMPLY WITH APPLICABLE PROVISIONS OF CHAPTER 23 OF THE 2012 NCSBC.
- SHEATHING SHALL BE FASTENED IN ACCORDANCE WITH PLANS SHOWN SPECIAL NAILING REQUIREMENTS AND WITH THE APPROPRIATE SCHEDULE IN CHAPTER 23, UNLESS NOTED OTHERWISE.
- IN GENERAL, SHEETS SHALL BE 4'-0"x8'-0" AND SHALL BE LAID WITH FACE PLIES ACROSS FRAMING MEMBERS AND WITH END JOINTS STAGGERED 4'-0". NO PANEL SHALL BE USED WHICH IS LESS THAN 24" IN WIDTH ON FLOORS AND ROOFS. SHEATHING SHALL BE CONTINUOUS ACROSS 2 SPANS, MINIMUM.

**PRE-ENGINEERED WOOD ROOF TRUSSES:**

- ENGINEERED WOOD TRUSS SYSTEMS SHALL BE DESIGNED BY SUPPLIER TO THE CONFIGURATION AND LOAD-CARRYING CAPACITY SHOWN ON THE DRAWINGS AND SPECIFICATIONS. TRUSSES SHALL BE DESIGNED TO SUSTAIN SELF WEIGHT OF THE TRUSSES AND UNIFORM LOADS AS INDICATED ON THIS SHEET AND AS FOLLOWS:  
A) TOP CHORD: DEAD LOAD = 10 psf  
LIVE LOAD = 20 psf  
SNOW LOAD = 6.3 psf  
WIND LOAD = SEE DESIGN LOADS  
B) BOTTOM CHORD: DEAD LOAD = 10 psf  
LIVE LOAD = 10 psf

**WOOD FRAMING CONNECTIONS:**

- CONNECTOR MODEL NUMBERS SHOWN ARE "Strong-Tie" CONNECTORS AS MANUFACTURED BY "SMIPSON Strong-Tie Co.", 1450 DODDLETTLE DR., PO BOX 1568, SAN LEANDRO, CA 94577. SUBSTITUTIONS ARE ACCEPTABLE ONLY WITH THE APPROVAL OF THE STRUCTURAL ENGINEER.
- ALL CONNECTORS SHALL BE GALVANIZED IN ACCORDANCE WITH ASTM A653. CONNECTORS IN CONTACT WITH PRESSURE TREATED MATERIALS SHALL HAVE G-185 COATING. CONNECTORS NOT IN CONTACT WITH TREATED MATERIALS SHALL HAVE STANDARD G-60 COATING.

**STRUCTURAL STEEL:**

- STEEL SHALL CONFORM TO ASTM A992 (Fy=50 ksi) FOR ALL W-SHAPES, AND ASTM A36 (Fy=36 ksi) FOR ALL OTHER MISCELLANEOUS SHAPES AND PLATES. STRUCTURAL TUBING SHALL CONFORM TO ASTM A500, GRADE B (Fy=46 ksi). STRUCTURAL PIPE SHALL CONFORM TO ASTM A53, GRADE B, TYPE "E" OR "S" (Fy=42 ksi).

- STEEL SHALL CONFORM TO THE LATEST EDITION OF "SPECIFICATION FOR THE DESIGN, FABRICATION AND ERECTION OF STRUCTURAL STEEL FOR BUILDINGS" BY THE AMERICAN INSTITUTE OF STEEL CONSTRUCTION, INC (AISC).
- ALL STRUCTURAL STEEL EXPOSED TO EXTERIOR SHALL BE HOT-DIPPED GALVANIZED.
- ALL SHOP CONNECTIONS TO BE WELDED (UTILIZING E70XX ELECTRODES) AND FIELD CONNECTIONS TO BE BOLTED, UNLESS OTHERWISE NOTED. STEEL TO RECEIVE ONE SHOP COAT AND ONE FIELD TOUCH UP COAT OF APPROVED PAINT, EXCEPT WHERE GALVANIZED IS INDICATED ON THE DRAWINGS.
- WELDS FOR ALL EXPOSED STRUCTURAL STEEL SHALL BE GROUND SMOOTH UNLESS NOTED OTHERWISE.
- ALL BOLTED CONNECTIONS SHALL CONSIST OF 3/4" DIAMETER (MIN.) ASTM A325 HIGH STRENGTH BOLTS, UNLESS NOTED OTHERWISE. BEAM CONNECTIONS SHALL BE DESIGNED BY THE FABRICATOR TO SUPPORT AN END REACTION OF WGL KIPS IN ACCORDANCE WITH PART 2 - "BEAM AND GIRDER DESIGN" OF THE MANUAL OF STEEL CONSTRUCTION (9th EDITION), BUT CONNECTIONS SHALL NOT HAVE LESS THAN 2 ROWS OF BOLTS. SEE ALSO DOUBLE ANGLE AND SHEAR TAB CONNECTION SCHEDULE(S) WHERE APPLICABLE.
- CONTRACTOR TO FURNISH AND INSTALL 500 lbs. OF ADDITIONAL MISCELLANEOUS STEEL TO BE USED AT ENGINEER'S DISCRETION.

**CONCRETE TESTING:**

- CONCRETE TESTING SHALL BE PAID FOR BY THE OWNER. TESTING LABORATORY SHALL PERFORM THE FOLLOWING TESTS ON CAST-IN-PLACE CONCRETE:  
A) ASTM C143 - "STANDARD TEST METHOD FOR SLUMP OF PORTLAND CEMENT CONCRETE"  
B) ASTM C231 - "STANDARD TEST METHOD FOR COMPRESSIVE STRENGTH OF CYLINDRICAL CONCRETE SPECIMENS". A SEPARATE TEST SHALL BE CONDUCTED FOR EACH CLASS, FOR EVERY 50 CUBIC YARDS (OR FRACTION THEREOF), PLACED PER DAY. REQUIRED CYLINDER(S) QUANTITIES AND TEST AGE AS FOLLOWS:  
1 AT 7 DAYS  
2 AT 28 DAYS

PROVIDE ONE ADDITIONAL RESERVE CYLINDER TO BE TESTED UNDER THE DIRECTION OF THE ENGINEER. IF REQUIRED, IF 28 DAY STRENGTH IS ACHIEVED, THE ADDITIONAL CYLINDER(S) MAY BE DISCARDED.

**PENETRATIONS:**

NO PENETRATIONS SHALL BE MADE IN ANY STRUCTURAL MEMBERS OTHER THAN THOSE LOCATED ON THESE DRAWINGS WITHOUT PREVIOUS APPROVAL OF THE ENGINEER.

**CONCRETE MIX DESIGN:**

- SHALL BE MIX DESIGNED BY A RECOGNIZED TESTING LABORATORY TO ACHIEVE A STRENGTH AT 28 DAYS AS LISTED BELOW WITH A PLASTIC AND WORKABLE MIX:  
3,000 psi - FOUNDATION WALLS AND FOOTINGS  
INTERIOR SLABS ON-GRADE  
4,000 psi - ALL OTHER CONCRETE

- SUBMIT PROPOSED MIX DESIGN WITH RECENT FIELD CYLINDER OR LAB TESTS FOR REVIEW PRIOR TO USE. MIX SHALL BE UNIQUELY IDENTIFIED BY MIX NUMBER OR OTHER POSITIVE IDENTIFICATION. CONCRETE SHALL COMPLY WITH ALL THE REQUIREMENTS OF ASTM STANDARD C94 FOR MEASURING, MIXING, TRANSPORTING, ETC. CONCRETE TICKETS SHALL BE TIME STAMPED WHEN CONCRETE IS BATCHED. THE MAXIMUM TIME ALLOWED FROM THE TIME THE MIXING WATER IS ADDED UNTIL IT IS DEPOSITED IN ITS FINAL POSITION SHALL NOT EXCEED ONE AND ONE HALF (1-1/2) HOURS. IF FOR ANY REASON THERE IS A LONGER DELAY THAN STATED ABOVE, THE CONCRETE SHALL BE DISCARDED. IT SHALL BE THE RESPONSIBILITY OF THE TESTING LAB TO NOTIFY THE OWNER'S REPRESENTATIVE AND THE CONTRACTOR OF ANY NONCOMPLIANCE WITH THE ABOVE. ALL SLABS SHALL BE CURED USING CURING COMPOUND MEETING ASTM STANDARD C309 TYPE 1 AND SHALL HAVE A FUGITIVE DYE. THE COMPOUND SHALL BE PLACED AS SOON AS THE FINISHING IS COMPLETED OR AS SOON AS THE WATER HAS LEFT THE UNFINISHED CONCRETE. ALL SCURED OR BROKEN AREAS IN THE CURING MEMBRANE SHALL BE RECOATED DAILY. CALCIUM CHLORIDES SHALL NOT BE UTILIZED; OTHER ADMIXTURES MAY BE USED ONLY WITH THE APPROVAL OF THE ENGINEER.

- CONCRETE SHALL UTILIZE TYPE III CEMENT UNLESS OTHERWISE DIRECTED BY THE GEOTECHNICAL ENGINEER OR GEOTECHNICAL REPORT.

- THE CONCRETE STRENGTHS SHOWN IN THE SECTION ABOVE AND IN THE SPECIFICATIONS ARE MINIMUM COMPRESSIVE STRENGTHS. THE ENGINEER SHALL DETERMINE IF THE CONCRETE IS ACCEPTABLE, OR TO BE REMOVED, OR TO RECEIVE SPECIAL CURING IF THE COMPRESSIVE STRENGTHS ARE LESS THAN SPECIFIED.

- ALL CONCRETE EXPOSED TO WEATHER OR EARTH SHALL BE AIR ENTRAINED TO 5% TO 7%.

- WATER REDUCING AGENTS MAY BE USED IN THE CONCRETE MIX. PLASTICIZERS AND SUPER-PLASTICIZERS MAY BE USED ONLY WHEN WRITTEN PERMISSION OF THE ENGINEER IS GIVEN.

- NO SALTS OF ANY KIND MAY BE USED IN CONCRETE BEFORE OBTAINING THE ENGINEER'S WRITTEN PERMISSION FOR THEIR USE.

- CONCRETE FOR TROWEL-FINISHED INTERIOR CONCRETE FLOORS SHALL NOT INCLUDE AN AIR-ENTRAINING ADMIXTURE. THE MAXIMUM AIR CONTENT IN THESE SLABS SHALL NOT EXCEED 3%.

**CONCRETE AND REINFORCING PLACEMENT:**

- ALL CONCRETE SHALL BE PLACED IN ACCORDANCE WITH ACI 301 AND ACI 117 EXCEPT AS MODIFIED BELOW:  
ACI 117 ITEM 4.3.1.1 ELEVATIONS OF SLABS ON-GRADE TOP OF SLAB ELEVATION SHALL BE WITHIN A 3/8" ENVELOPE EITHER SIDE OF THE THEORETICAL DESIGN SURFACE.  
ACI 117 ITEM 4.5.1.7 FLOOR FINISH TOLERANCES AS MEASURED BY PLACING A FREESTANDING (UNLEVELED) 10 FT. STRAIGHTEDGE ANYWHERE ON THE SLAB AND ALLOWING IT TO REST UPON TWO HIGH SPOTS WITHIN 28 DAYS AFTER SLAB CONCRETE PLACEMENT. THE GAP AT ANY POINT BETWEEN THE STRAIGHTEDGE AND THE FLOOR SHALL NOT EXCEED 1/4".

- ALL REINFORCING STEEL TO BE ASTM A615, GRADE 60 (#4 AND LARGER), EXCEPT WHERE NOTED OTHERWISE. REINFORCING SHALL NOT BE WELDED.

- WELDED WIRE FABRIC TO CONFORM TO ASTM A185 AND SHALL BE FREE FROM OIL, SCALE AND RUST. PLACE WWF IN ACCORDANCE WITH THE TYPICAL PLACING DETAILS OF ACI STANDARDS AND THE SPECIFICATIONS. MINIMUM LAPS SHALL BE ONE SPACE PLUS 2".

- ALL REINFORCING STEEL BARS TO BE DETAILED AND PLACED IN ACCORDANCE WITH THE LATEST ACI MANUALS.

- LAP ALL REINFORCING SPLICES IN CONCRETE A MINIMUM OF 48 BAR DIAMETERS OR 24 INCHES, WHICHEVER IS GREATER, UNLESS NOTE OTHERWISE ON DRAWINGS (CLASS B SPLICE).

- PROVIDE CORNER BARS OF SAME BAR DIAMETER AS SPECIFIED FOR THE WALL, BEAM OR FOOTING. PROVIDE MINIMUM OF 40 BAR DIAMETER LAP FOR ALL CORNER BARS, UNLESS NOTED OTHERWISE.

- PROVIDE FOUNDATION DOWELS AS SHOWN. MINIMUM SIZE DOWELS TO BE # 4 UNLESS OTHERWISE NOTED. ALL VERTICAL REINFORCING STEEL IN COLUMNS AND PIERS, OR VERTICAL REINFORCING IN WALLS, SHALL BE DOWELED INTO THE FOOTINGS WITH SAME SIZE AND QUANTITY DOWEL AS THE VERTICAL REINFORCING.

- WHERE SHOWN ON THE DRAWINGS, PROVIDE WELD PLATES, WELDMENTS, OR CONCRETE INSERTS FOR FASTENING AND SECURING OTHER COMPONENTS. CONCRETE INSERTS SHALL BE FURNISHED BY THE CONTRACTOR REQUIRING THEM AND INSTALLED BY THE CONTRACTOR CASTING THE CONCRETE AROUND THEM. CLIP ANGLES SHALL BE FURNISHED BY THE CONTRACTOR REQUIRING THEM.

- REINFORCING STEEL SHALL RECEIVE CONCRETE COVER AS FOLLOWS:

DESCRIPTION	MINIMUM COVER
CAST AGAINST AND PERMANENTLY EXPOSED TO EARTH	3"
EXPOSED TO EARTH OR WEATHER #6 THROUGH #18 BARS	2"
#5 BARS OR SMALLER	1 1/2"
NOT EXPOSED TO EARTH OR WEATHER OR IN CONTACT WITH THE GROUND, SLABS AND WALLS	3/4"
#11 BARS OR SMALLER #14 AND #18	1 1/2"
BEAMS AND COLUMNS	1 1/2"

- PROVIDE TWO (2) #5'S, ONE AT EACH FACE, UNLESS NOTED OTHERWISE, AROUND ALL OPENINGS GREATER THAN 12"x12" IN CAST-IN-PLACE CONCRETE. EXTEND REINFORCING 2'-0" BEYOND OPENINGS IN BOTH DIRECTIONS. CONTACT ENGINEER FOR ALL OPENINGS GREATER THAN 12"x12" FOR DESIGN.

- COLD WEATHER AND HOT WEATHER PROVISIONS OF ACI 306 AND 305 (CURRENT EDITIONS), RESPECTIVELY, SHALL BE MAINTAINED.
- CONTRACTOR TO FURNISH AND INSTALL 500 LINEAR FT. EACH OF ADDITIONAL #4 & #5 REINFORCING STEEL TO BE USED AT ENGINEER'S DISCRETION.

**FORMWORK AND SHORING:**

NO STRUCTURAL CONCRETE SHALL BE STRIPPED UNTIL IT HAS REACHED AT LEAST TWO-THIRDS OF THE 28 DAY DESIGN STRENGTH. DESIGN, ERECTION AND REMOVAL OF ALL FORMWORK, SHORES AND RESHORES SHALL MEET THE REQUIREMENTS SET FORTH IN ACI STANDARDS 301 AND 347.

**STRUCTURAL NOTES**

**GENERAL NOTES:**

- STRUCTURAL DRAWINGS SHALL BE USED IN CONJUNCTION WITH JOB SPECIFICATIONS AND ARCHITECTURAL, MECHANICAL, ELECTRICAL, PLUMBING AND SITE DRAWINGS. CONSULT THESE DRAWINGS FOR SLEEVES, DEPRESSIONS AND OTHER DETAILS NOT SHOWN ON STRUCTURAL DRAWINGS.
- ALL DIMENSIONS AND CONDITIONS MUST BE VERIFIED IN THE FIELD AND WITH ALL OTHER DRAWINGS. ANY DISCREPANCIES SHALL BE BROUGHT TO THE ATTENTION OF THE ENGINEER BEFORE PROCEEDING WITH THE AFFECTED PART OF THE WORK.
- THE STRUCTURE IS DESIGNED TO BE SELF SUPPORTING AND STABLE AFTER THE BUILDING IS COMPLETE. IT IS THE CONTRACTOR'S SOLE RESPONSIBILITY TO DETERMINE ERECTION PROCEDURES AND SEQUENCE TO ENSURE SAFETY OF THE BUILDING AND ITS COMPONENTS DURING ERECTION. THIS INCLUDES THE ADDITION OF NECESSARY SHORING, SHEETING, TEMPORARY BRACING (AND ACCOMPANYING FOOTINGS), GUYS OR TIEDOWNS.
- ADDITIONAL OBSERVATIONS AS A RESULT OF REJECTION OF WORK COMPLETED AND/OR ADDITIONAL OBSERVATIONS DUE TO THE DEFICIENCIES IN WORK OBSERVED WILL BE AT THE EXPENSE OF THE CONTRACTOR.
- ALL STRUCTURAL SHOP DRAWINGS TO BE REVIEWED BY JOB SUPERINTENDENT IN ADDITION TO ALL PERSONNEL DEEMED NECESSARY BY CONTRACTOR PRIOR TO SUBMITTAL TO ENGINEER FOR APPROVAL.
- ALL SHOP DRAWING RESUBMITTALS SHALL INCLUDE A WRITTEN DETAILED LIST OF LOCATIONS AND DESCRIPTIONS OF ALL CHANGES MADE FROM PREVIOUS SUBMITTAL. LIST SHALL BE SPECIFIC AND GENERAL NOTES SUCH AS "DIMENSIONS CORRECTED" ARE NOT ACCEPTABLE.

**DESIGN CODES:**

2018 NORTH CAROLINA STATE BUILDING CODE.  
ACI 318-19 BUILDING CODE REQUIREMENTS FOR STRUCTURAL CONCRETE AND COMMENTARY.

2018 NATIONAL DESIGN SPECIFICATIONS (NDS) FOR WOOD CONSTRUCTION  
AISC: SPECIFICATION FOR STRUCTURAL STEEL BUILDINGS, ALLOWABLE STRESS DESIGN.

**DESIGN LOADS:**

THE STRUCTURAL SYSTEM FOR THIS BUILDING HAS BEEN DESIGNED WITH THE FOLLOWING SUPERIMPOSED LOADS:

ROOF:	
GROUND SNOW LOAD,	Pg = 10 psf
DESIGN ROOF SNOW LOAD,	Pf = 10 psf
SNOW EXPOSURE FACTOR,	Ce = 0.9
SNOW LOAD IMPORTANCE FACTOR,	Is = 1.0
THERMAL FACTOR,	Ct = 1.2
ROOF LIVE LOAD	20 psf
DESIGN LIVE LOADS:	
FLOOR	100 psf

WIND:	
BASIC WIND SPEED (3 SEC GUST)	115 mph
EXPOSURE CATEGORY	C
RISK CATEGORY	II
WIND BASE SHEARS,	Vx = 17.9k Vy = 46.3k

COMPONENT & CLADDING:  
ALL BUILDING COMPONENTS AND CLADDING ENGINEERED BY THE COMPONENT MANUFACTURER ARE TO BE DESIGNED BY THE MANUFACTURER'S ENGINEER FOR WIND LOADS DETERMINED PER THE NORTH CAROLINA STATE BUILDING CODE FOR THE BASIC DESIGN WIND VELOCITY, IMPORTANCE FACTOR AND EXPOSURE LISTED ABOVE.

SEISMIC:	
IMPORTANCE FACTOR,	ie = 1.0
USE GROUP	I
MAPPED SPECTRAL RESPONSE ACCELERATIONS,	Ss = 0.139g S1 = 0.067g
SPECTRAL RESPONSE COEFF.,	Sis = 0.149g Sd1 = 0.108g
SEISMIC RESISTING SYSTEM:	
ORDINARY WOOD SHEATHED SHEAR WALLS	

**FOUNDATIONS:**

FOUNDATIONS ARE DESIGNED FOR AN ALLOWABLE SOIL BEARING PRESSURE OF 2,000 psf ON EXISTING SOILS. BEFORE CONSTRUCTION COMMENCES, SOIL BEARING CAPACITY SHALL BE VERIFIED BY A SUBSURFACE INVESTIGATION, A CERTIFIED TESTING LABORATORY, WHOSE REPORT SHALL INCLUDE ANALYSIS AND RECOMMENDATIONS FOR SITE PREPARATION IN ORDER TO BEAR THE FOUNDATION LOADS. ABOVE REPORT SHALL BE SUBMITTED TO THE STRUCTURAL ENGINEER FOR REVIEW BEFORE FOUNDATION CONSTRUCTION BEGINS.

**PLUMBING SLEEVES:**

MINIMUM SLEEVE SPACING SHALL BE TWO DIAMETERS CENTER TO CENTER TO THE LARGER SLEEVE OR 6" CLEAR BETWEEN SLEEVES, WHICHEVER IS GREATER. PRIOR TO CONSTRUCTION SLEEVE LOCATIONS AND SIZES SHALL BE APPROVED BY THE STRUCTURAL ENGINEER OF RECORD.

**CHEMICAL ANCHORS:**

SHALL BE A POLYMER INJECTION SYSTEM SUCH AS RAMSET "EPCON", MOLLY "PARAMOUNT HV", SIKA "SIKADUR INJECTION SEL", "HILTI-HIGH STRENGTH EPOXY", OR APPROVED EQUAL, INSTALLED IN ACCORDANCE WITH THE MANUFACTURERS INSTRUCTIONS. INSTALLERS SHALL BE TRAINED BY THE MANUFACTURER'S REPRESENTATIVE.

**ANCHOR BOLTS:**

SHALL BE A36 THREADED ROD. PROVIDE HOT DIP GALVANIZED FINISH ON ALL ANCHOR BOLTS PERMANENTLY EXPOSED TO EXTERIOR.

Ownership of Instruments of Service: All reports, plans, specifications, computer files, field data, notes and instruments prepared by the design professional as instruments of service shall remain the property of the design professional. All common law, statutory and other reserved rights including the copyright therein.



WAKEBOARD DEALERSHIP

SANFORD, NC

Project Name

FOUNDATION PLAN

Sheet Title

DESIGNED BY: AJI

DRAWN BY: AJI

APPROVED BY: HMM

PROJECT #: 24-067

DATE: 11/27/2024

No.	Revision	Date

Sheet

## S2.1

FOR PERMIT ONLY

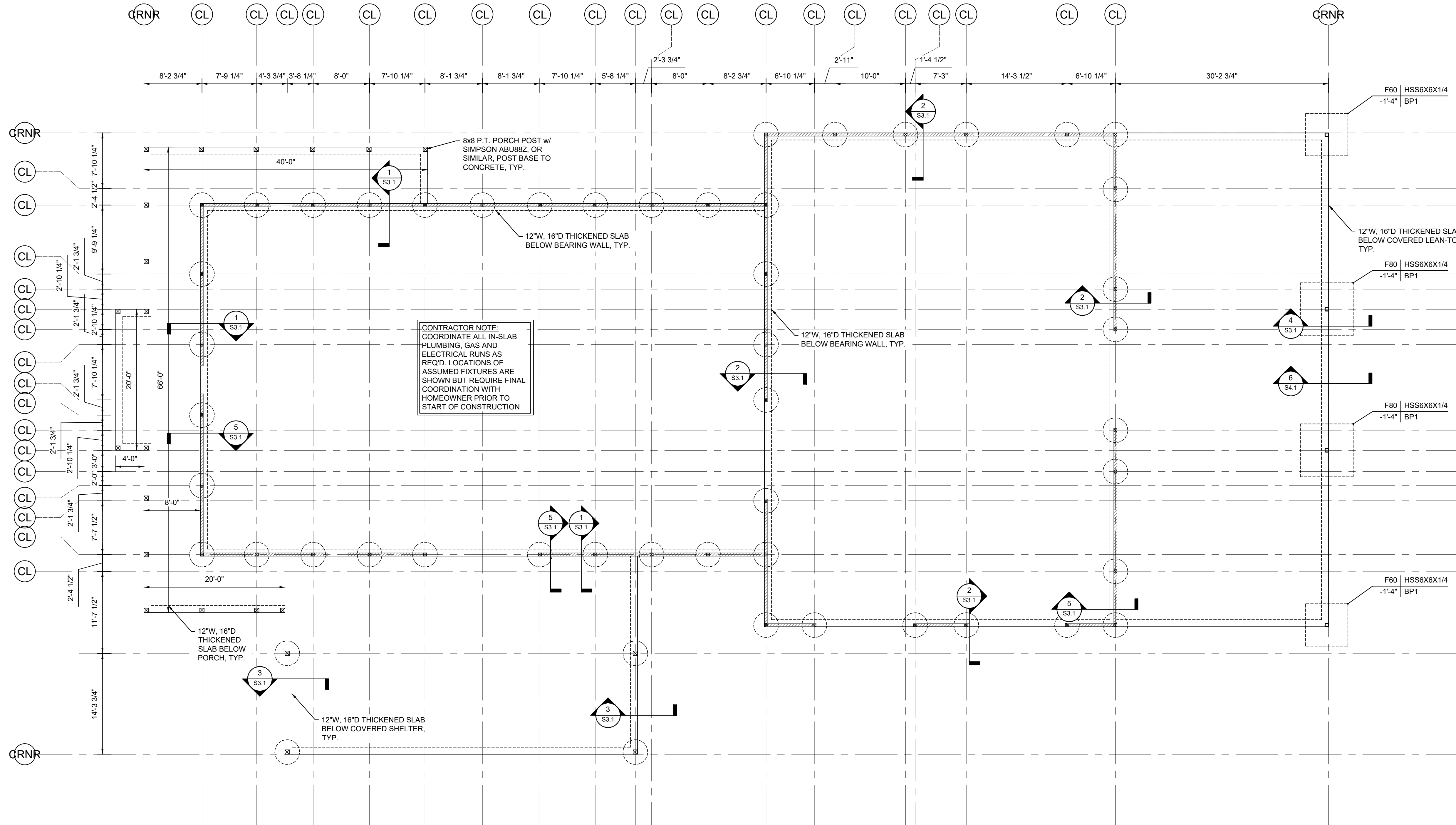

SPREAD FOOTING SCHEDULE		
MARK	SIZE	REINFORCING
F60	6'-0"x6'-0"x12"	(7)-#4 E.W. TOP & BOT
F80	8'-0"x8'-0"x12"	(9)-#4 E.W. TOP & BOT

1 FOUNDATION PLAN  
Scale: 1/8" = 1'-0"

Ownership of Instruments of Service: All reports, plans, specifications, computer files, field data, notes and instruments prepared by the design professional as instruments of service shall remain the property of the design professional. All common law, statutory and other reserved rights including the copyright therein.

**TRUSS DESIGN NOTES:**

- TRUSS MANUFACTURER SHALL BE RESPONSIBLE FOR FINAL TRUSS DESIGN, TO INCLUDE CALCULATIONS, LAYOUT, AND ALL NECESSARY BRACING AND BRIDGING DETAILS AS REQD. FOR PERMANENT STABILITY OF TRUSS SYSTEM.
- TRUSSES AND THEIR COMPONENTS ARE TO BE DESIGNED TO RESIST THE COMPONENT AND CLADDING WIND PRESSURES OUTLINED ON SHEET S1.0.
- TRUSSES ARE TO BE DESIGNED TO SUPPORT THE FOLLOWING SUPERIMPOSED LOADING UNLESS NOTED OTHERWISE:
  - TOP CHORD LL: 20 PSF
  - TOP CHORD DL: 10 PSF\*
  - BOTTOM CHORD DL: 5 PSF\*
- NET UPLIFT (MAIN): 21.3PSF  
 NET UPLIFT (SHELTER): 36.6PSF  
 NET UPLIFT (LEAN-TO): 36.6PSF  
 \*DEAD LOADS ARE CONSIDERED TO BE SUPERIMPOSED, AND DO NOT INCLUDE TRUSS SELF-WEIGHT

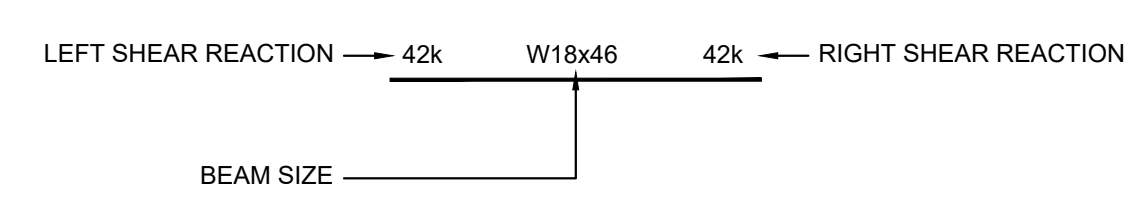
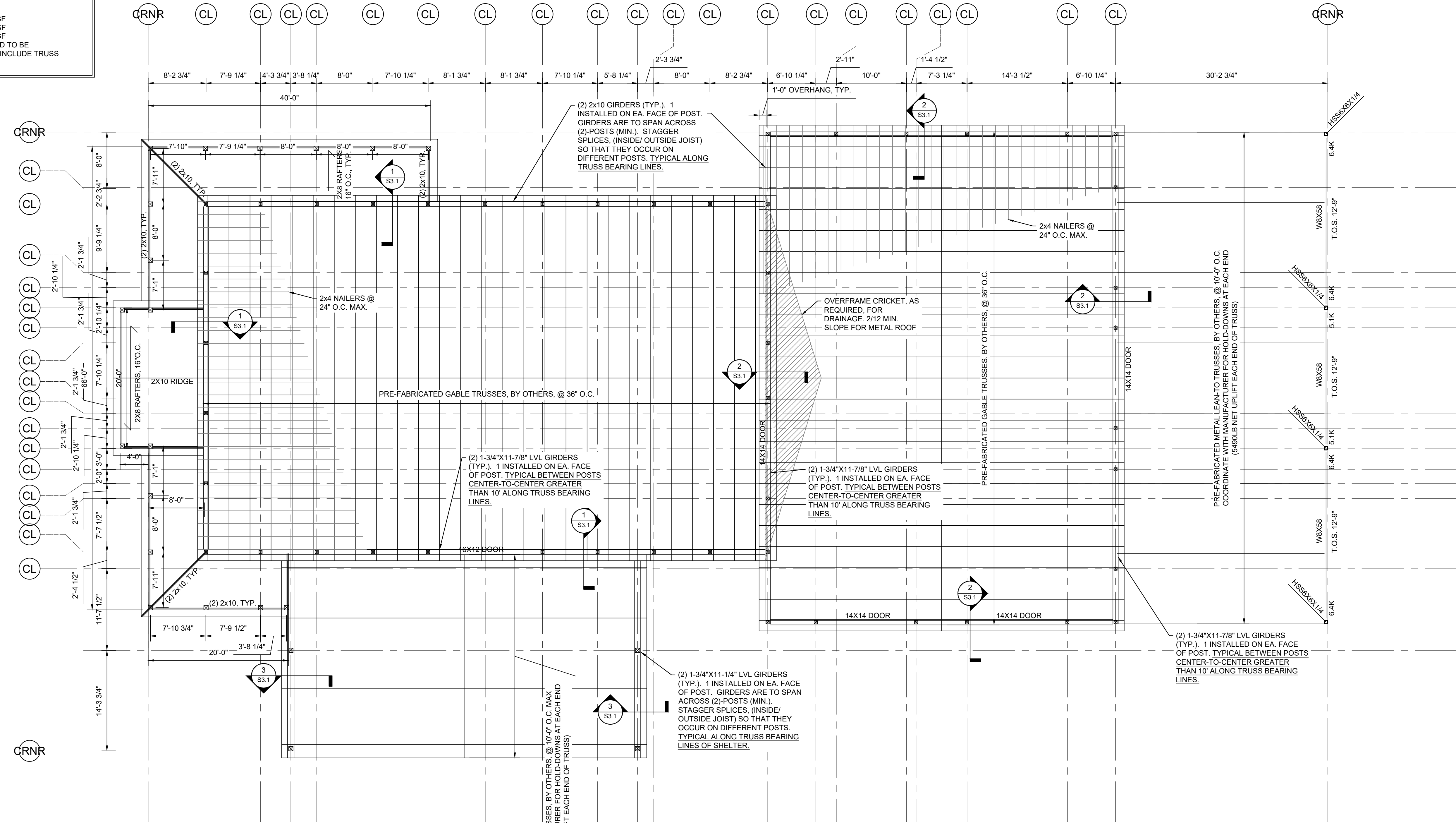

\*IF NO REACTIONS ARE PROVIDED, CONNECTIONS ARE TO BE DESIGNED FOR MINIMUM SHEAR REACTION OF 4k AND MINIMUM MOMENT REACTION OF 4k-ft

**1 ROOF FRAMING PLAN**  
Scale: 1/8" = 1'-0"

**FRAMING PLAN NOTES:**

- /// DENOTES LOAD BEARING WALL. ALL EXTERIOR WALLS SHALL BE SHEATHED WITH 7/16" APA 2448 SPAN RATED OSB SHEATHING WITH EDGE BLOCKING. NAIL SHEATHING WITH 8d NAILS @ 6" O.C. AT PANEL EDGES AND 12" O.C. AT INTERMEDIATE SUPPORTS.
- ALL EXTERIOR WALL FRAMING TO BE 2x6. ALL INTERIOR FRAMING TO BE 2x4, UNLESS NOTED OTHERWISE.
- ALL ROOF SHEATHING SHALL BE APA 32/16 SPAN RATED SHEATHING, 19/32" THICK (5/8" NOMINAL). PROVIDE H-CLIPS, U.N.O.
- (#) INDICATES NUMBER OF STUDS IN POST SUPPORTING FRAMING MEMBER. STUD POSTS SHALL EXTEND FROM BEARING DOWN TO SOLID FOUNDATION AND SHALL INCLUDE SOLID BLOCKING THROUGH FLOOR STRUCTURE DEPTH WHERE APPLICABLE. PROVIDE A MINIMUM OF (3) STUDS AT ALL BEAM BEARINGS UNLESS OTHERWISE NOTED ON PLAN.
- ALL EXTERIOR, AND INTERIOR LOAD-BEARING HEADERS TO BE CONSTRUCTED w/ MIN. (2)-2x10 AND SUPPORTED BY (2) JACK STUDS AND (2) KING STUD UNLESS NOTED OTHERWISE.
- PROVIDE SIMPSON H10A CLIPS AT THE ENDS OF ALL ROOF FRAMING MEMBERS U.N.O.

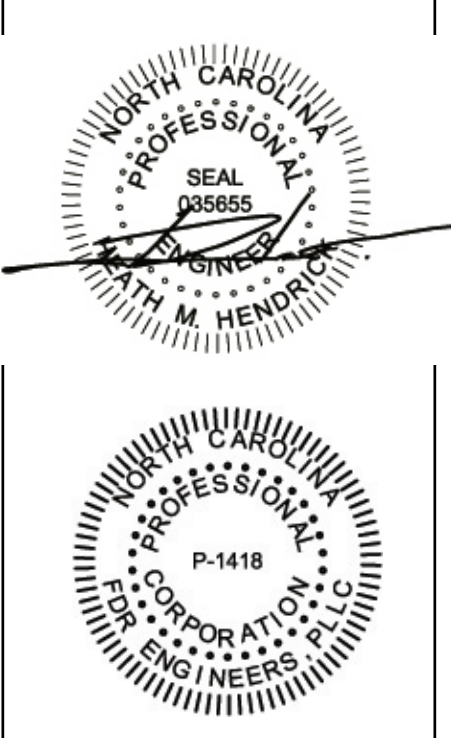

WAKEBOARD DEALERSHIP

SANFORD, NC

Project Name	ROOF FRAMING PLAN	
Sheet Title	ROOF FRAMING PLAN	
DESIGNED BY:	AJI	
DRAWN BY:	AJI	
APPROVED BY:	HMH	
PROJECT #:	24-067	
DATE:	11/27/2024	
No.	Revision	Date
Sheet	<b>S2.2</b>	

FOR PERMIT ONLY

Ownership of Instruments of Service: All reports, plans, specifications, computer files, field data, notes and instruments prepared by the design professional as instruments of service shall remain the property of the design professional. All common law, statutory and other reserved rights including the copyright therein.



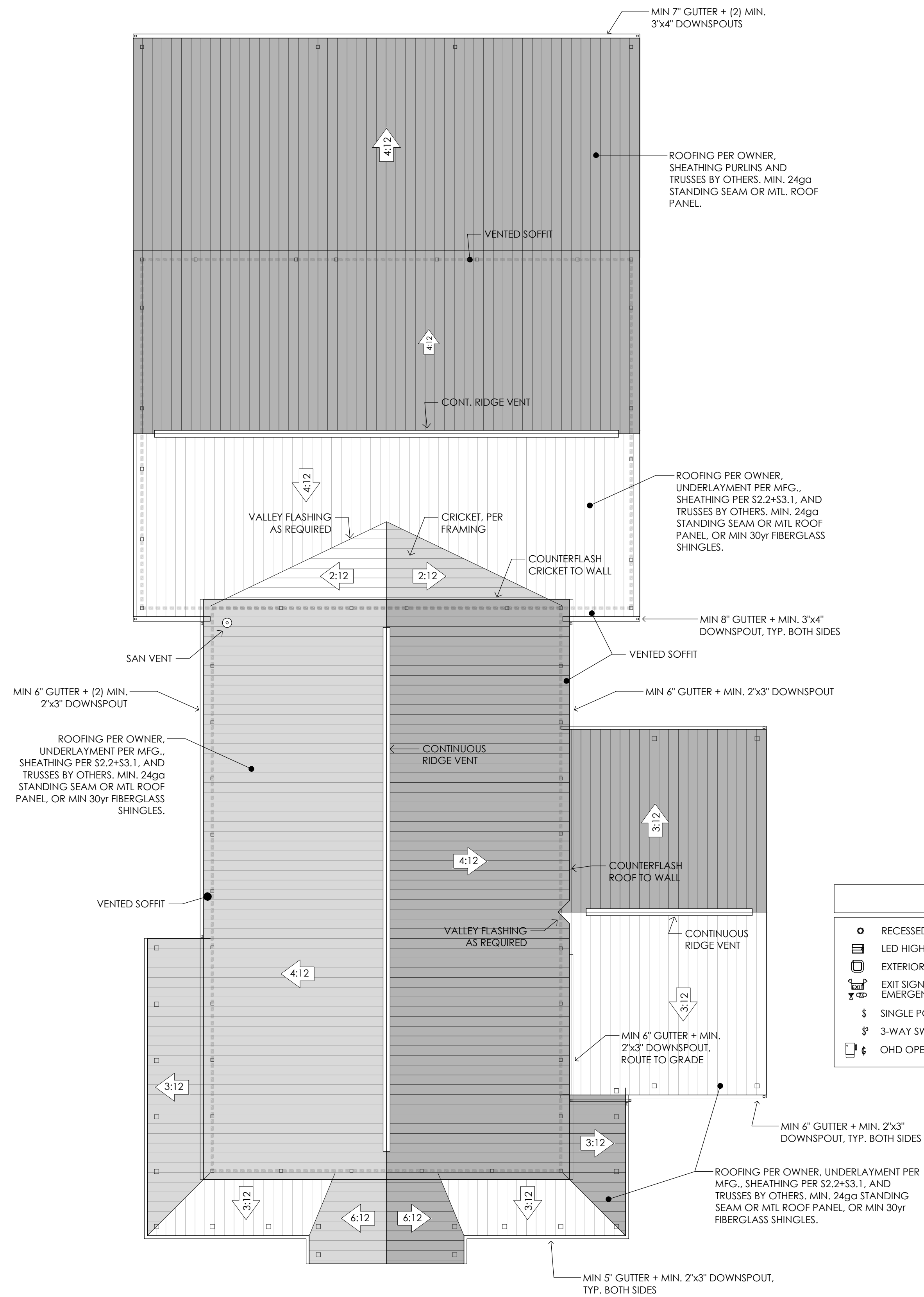

**2 ROOF LAYOUT**  
scale : 3/32" = 1'-0"

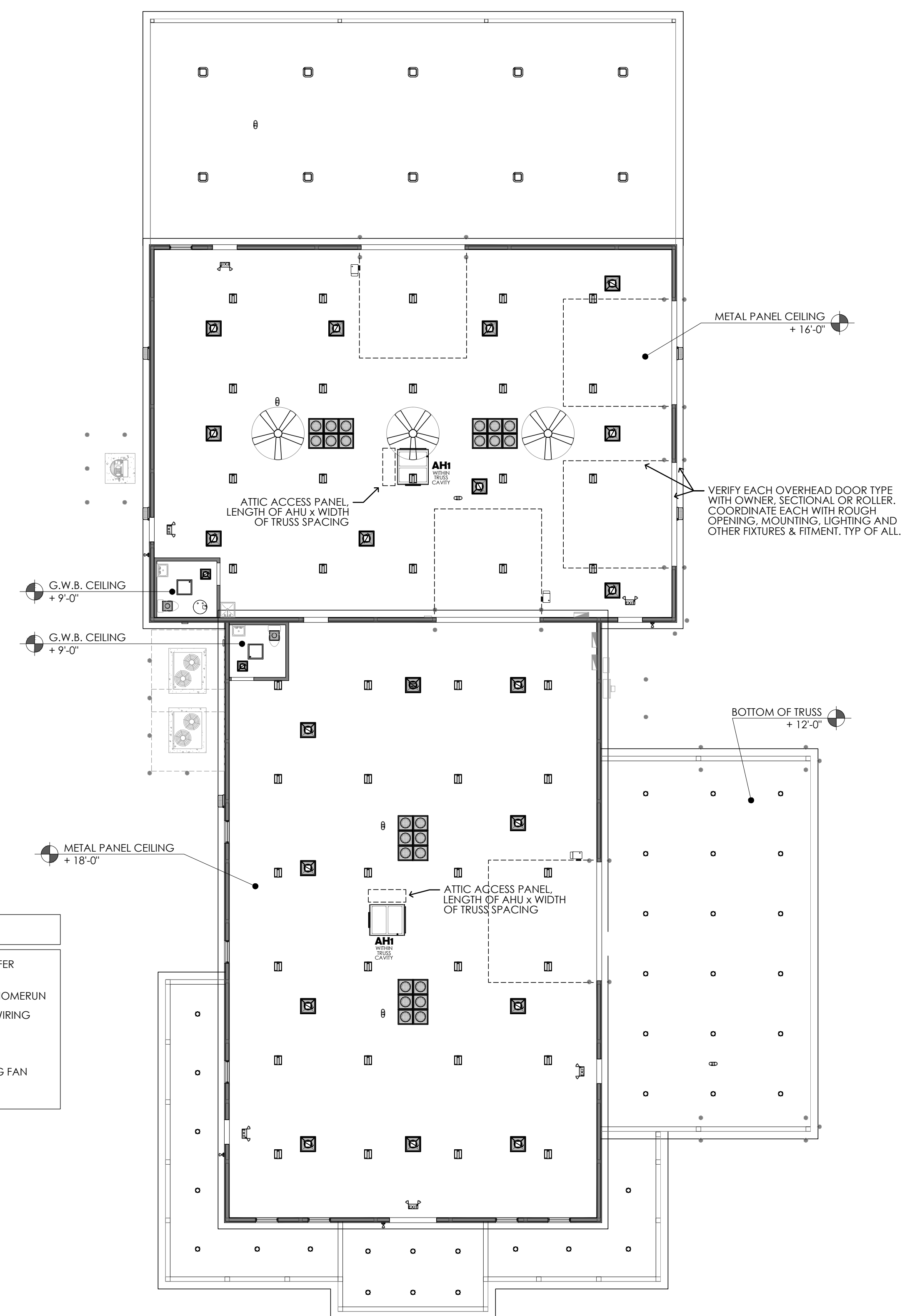

**1 REFLECTED CEILING LAYOUT**  
scale : 3/32" = 1'-0"

**LIGHTING LEGEND**

○	RECESSED DOWNLIGHT CAN	□	LED TROFFER FIXTURES
□	LED HIGH-BAY	⊕	CIRCUIT HOMERUN SWITCH WIRING
□	EXTERIOR LED HIGH-BAY	⊕	CEILING FAN
⊕	EXIT SIGNAGE & EMERGENCY LIGHTING		
⊕	SINGLE POLE SWITCH		
⊕	3-WAY SWITCH		
⊕	OHD OPENER & SWITCH		

**stormwater data** per '18 NCPC Table 1106.1 100-year 1-hour rainfall 4 in/hr  
per '18 NCPC Figure 1106.4 Vertical Walls 50%

by drainage areas	roof		volume			downspout			min. gutter W @ 0.8 W/H		
	area	adi. vert. wall length height	cu.ft.	cl.min.	g.p.m.	in. @	reqd.	prop.	size	in. @	
workshop N + lean-to	3,850	0 0	3,850 sf	1,283	21	160	3 x 4	2	2	1/8" (1%)	7"
workshop S	1,750	50 3	1,825 sf	608	10	76	2 x 3	2	2	1/8" (1%)	8"
showroom W	2,000	0 0	2,000 sf	667	11	83	2 x 3	2	2	1/8" (1%)	6"
showroom E	2,000	0 0	2,000 sf	667	11	83	2 x 3	2	2	1/8" (1%)	6"
side canopy N	725	25 3	763 sf	254	4	32	2 x 3	1	1	1/8" (1%)	5"
side canopy S	725	25 3	763 sf	254	4	32	2 x 3	1	1	1/8" (1%)	5"
veranda	1,092	96 3	1,236 sf	412	7	51	2 x 3	1	3	1/8" (1%)	5"

**LIGHTING SCHEDULE**

USE	TYPE	MANUF.	MODEL	LAMPS	Vg	V	DESCRIPTION
EXT. DOWNLIGHT	CAN	LITHONIA	LDN6 35/50 LD6AR	LED	35	120	NEW CONSTRUCTION 6" DOWNLIGHT CAN
WAREHOUSE	HIGH-BAY	LITHONIA	CPH8 15000LM SEF GCL	LED	96	120	HIGH BAY LED W MVOLT GANG TECHNOLOGY
EXT. CANOPY	HIGH-BAY	LITHONIA	SCNY LED ALO2 SW W 2 PFL	LED	5 130	120	HIGH BAY LED W MVOLT GANG TECHNOLOGY
2x2 TROFFER	CEILING	LITHONIA	2TL2 40L FW LP835	LED	40	120	2x2 LED TROFFER, 0.125" #12 ACRYLIC LENS, WHITE FINISH
EXTERIOR AREA	WALL	P.B.O.	P.B.O.	LED	5	90	ENCLOSED OR LIGHT SENS OR
EXIT + EM	STANDARD	LITHONIA	LHGM LED R HO	LED	10	120	EXIT + EMERG COMBO, WALL/CGL MTD, 90 MIN. BATT. BACK-UP, WHITE
EM	STANDARD	LITHONIA	ELMML	LED	8	120	HIGH BAY EXTER. WALL/CEILING MOUNTED, 90 MIN. BATTERY BACK-UP
EXT. EM	STANDARD	LITHONIA	ELA B T QWP LO309	LED	28	120	EXTERIOR/WET RATED, 2 LAMPS, BLACK FINISH, 90 MIN. BATTERY BACK-UP.

- LIGHT FIXTURE SUBSTITUTIONS ALLOWED WITH MATCHING PARAMETERS BY OWNER REQUEST, CODE COMPLIANCE AND AHJ APPROVAL.  
- OFFICES, BREAK ROOMS, RESTROOMS AND OTHER BUSINESS AREAS TO BE MOTION ACTIVATED TO 50%, MANUAL ON TO 100%, 30min MOTION SHUTOFF, AND MANUAL OFF.  
- TIME-SWITCH CONTROLS ARE PERMISSIBLE, PER OWNER, PROVIDED THAT PROGRAMMING IS 7-day CAPABLE AND NIGHT LIGHTING IS INCORPORATED.  
- E.C. TO COORDINATE ALL EXIT SIGNAGE AND EGRESS LIGHTING LOCATIONS, SELECTIONS AND SPACING, PRIOR TO PLACING ORDER, WITH OWNER AND AHJ.

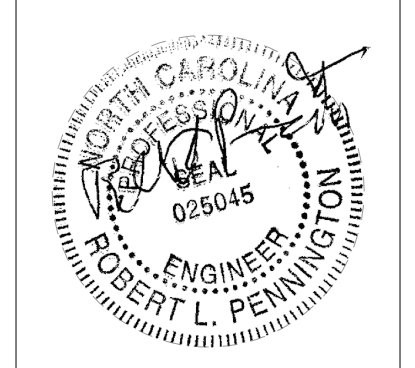

DESIGNED BY: SMB  
DRAWN BY: SMB  
APPROVED BY: RLP  
PROJECT #: R2408270  
DATE: 2024-10-23

#	Revision	Date
0	for permit	11/8/24

Ownership of Instruments of Service: All reports, plans, specifications, computer files, field data, notes and instruments prepared by the design professional as instruments of service shall remain the property of the design professional. All common law, statutory and other reserved rights including the copyright therein.

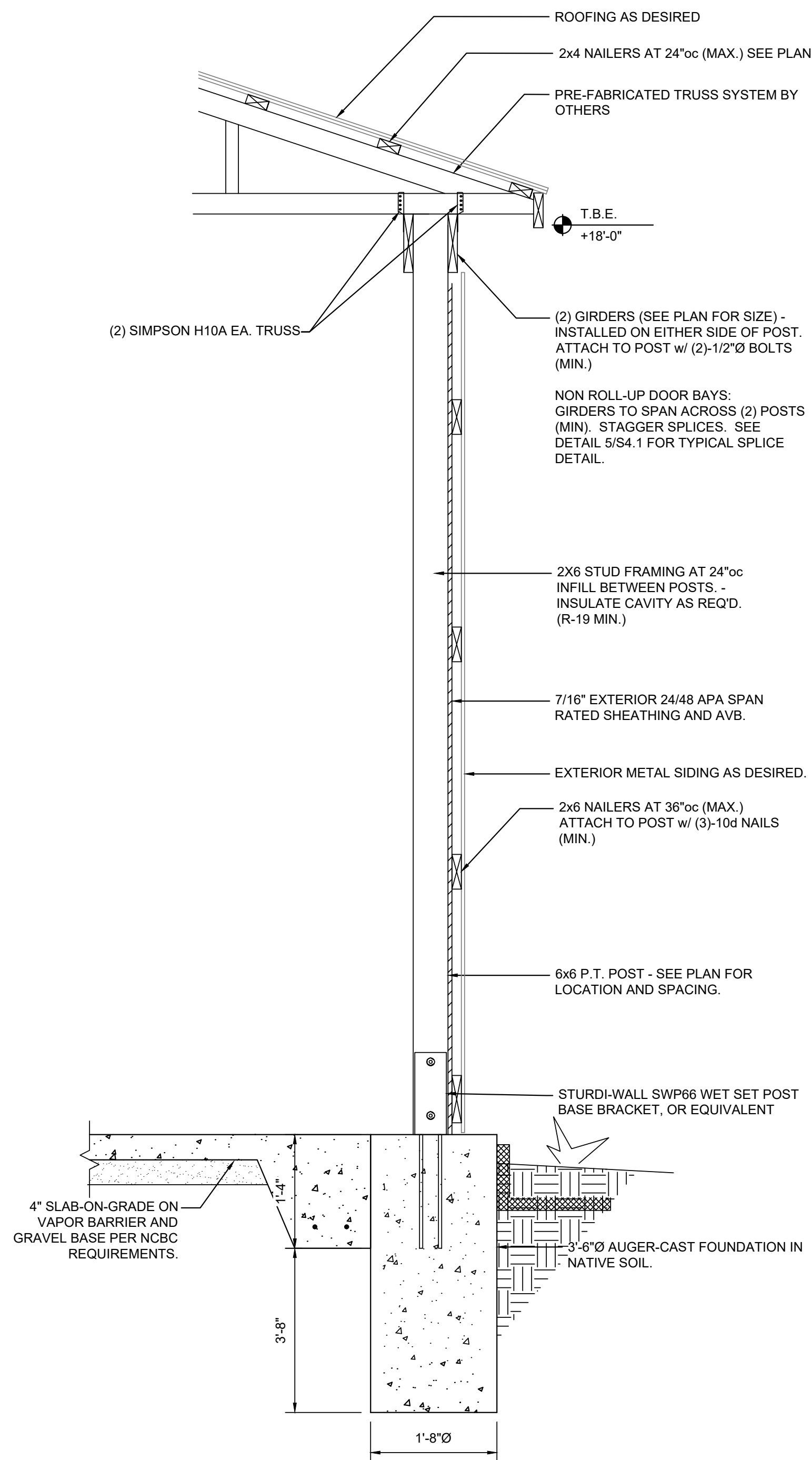

1 SECTION - POLE BARN WALL FRAMING  
SCALE: 3/4" = 1'-0"

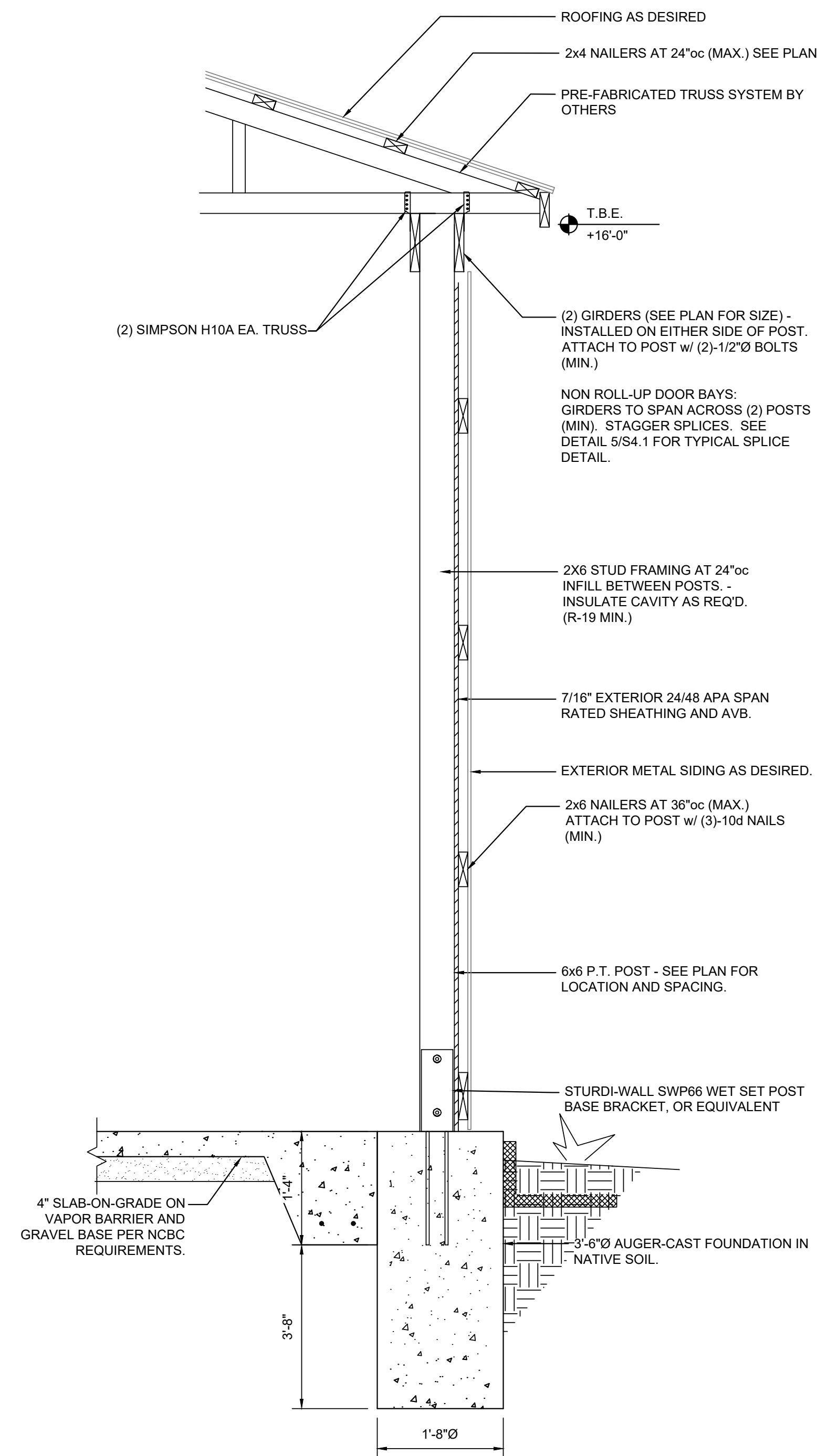

2 SECTION - POLE BARN WALL FRAMING  
SCALE: 3/4" = 1'-0"

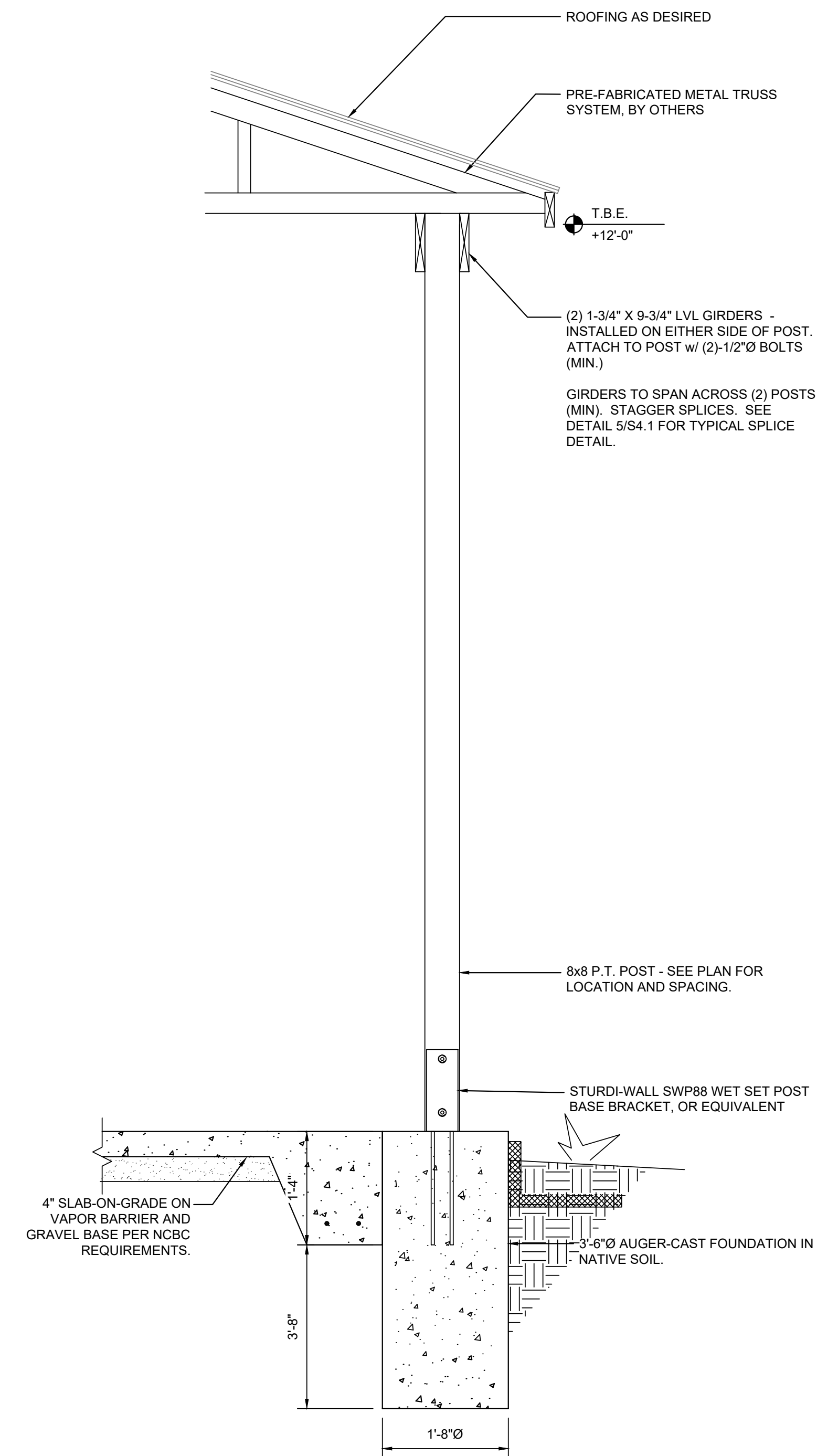

3 SHELTER - POLE BARN WALL FRAMING  
SCALE: 3/4" = 1'-0"

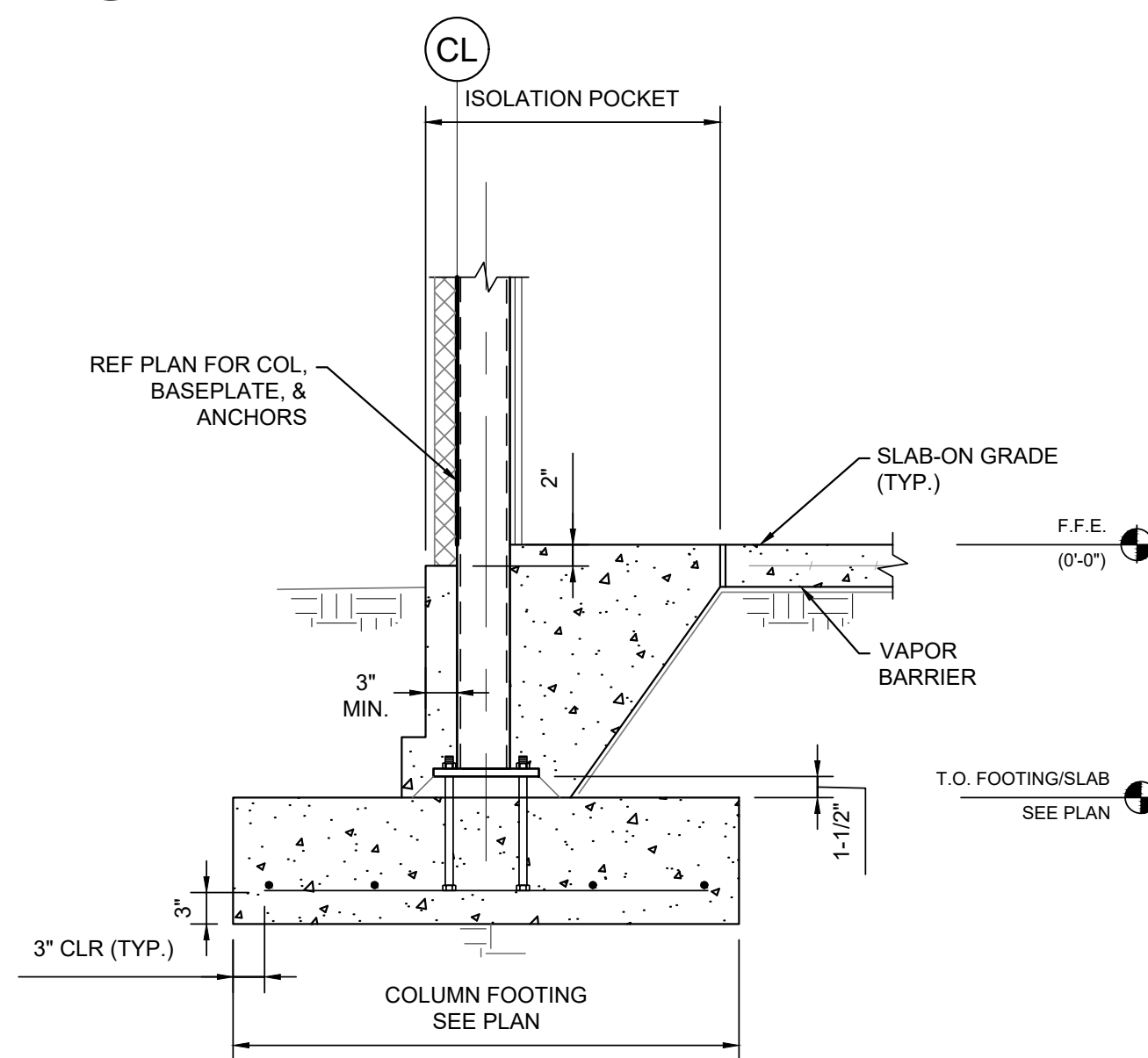

4 EXT. COLUMN FOOTING (TYP.)  
SCALE: 3/4" = 1'-0"

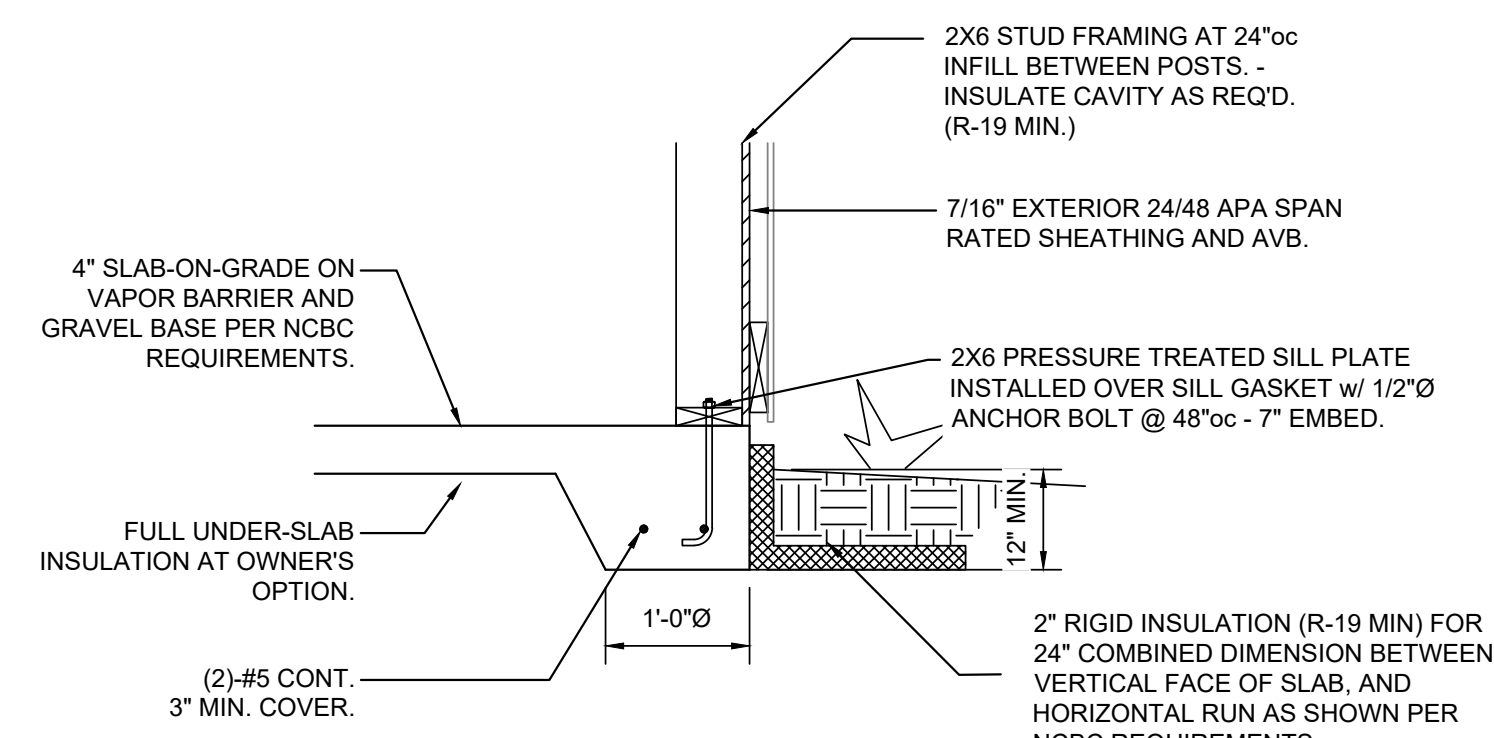

5 SECTION - PERIMETER SLAB ON GRADE  
SCALE: 3/4" = 1'-0"

DESIGNED BY:	AJI	
DRAWN BY:	AJI	
APPROVED BY:	HMH	
PROJECT #:	24-067	
DATE:	11/27/2024	
No.	Revision	Date

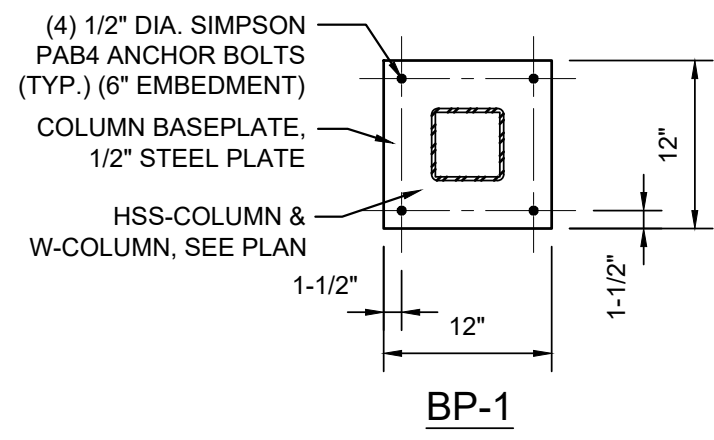

1 STEEL BASE PLATE DETAILS  
SCALE: 3/4" = 1'-0"

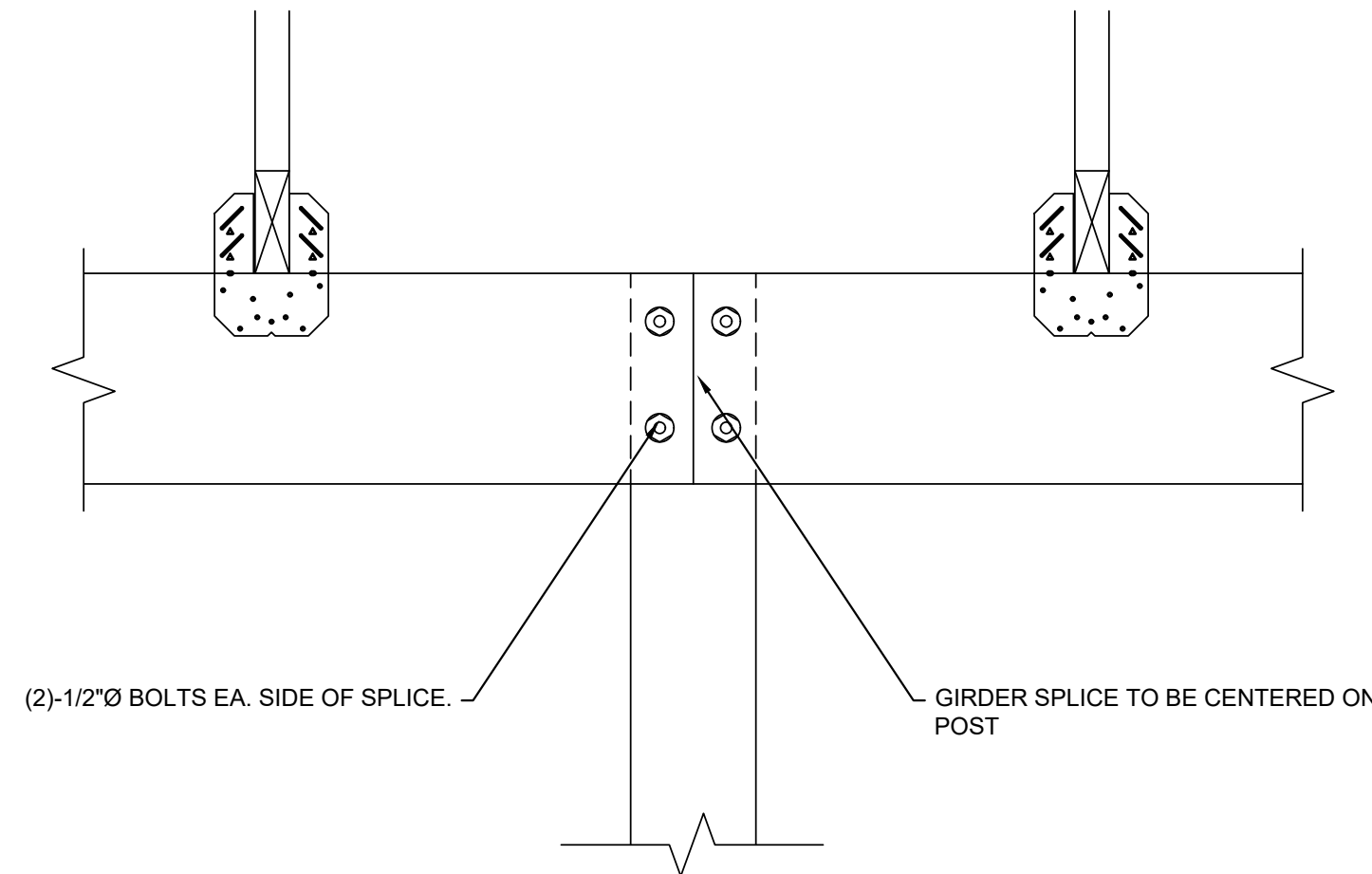

5 GIRDER SPLICE DETAIL  
SCALE: 1-1/2" = 1'-0"

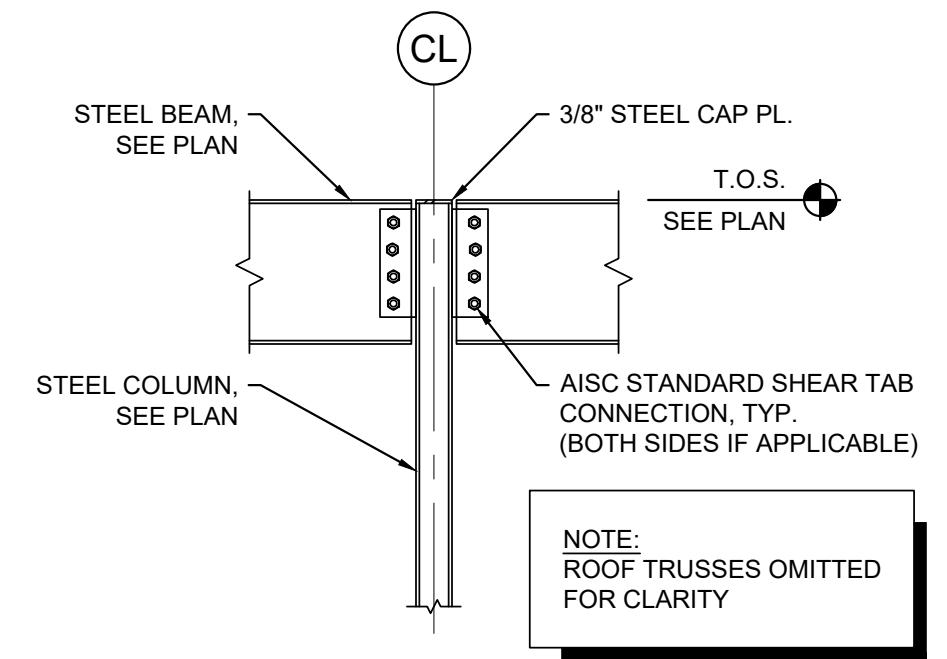

2 TYPICAL BEAM SHEAR CONNECTION  
Scale: 3/4" = 1'-0"

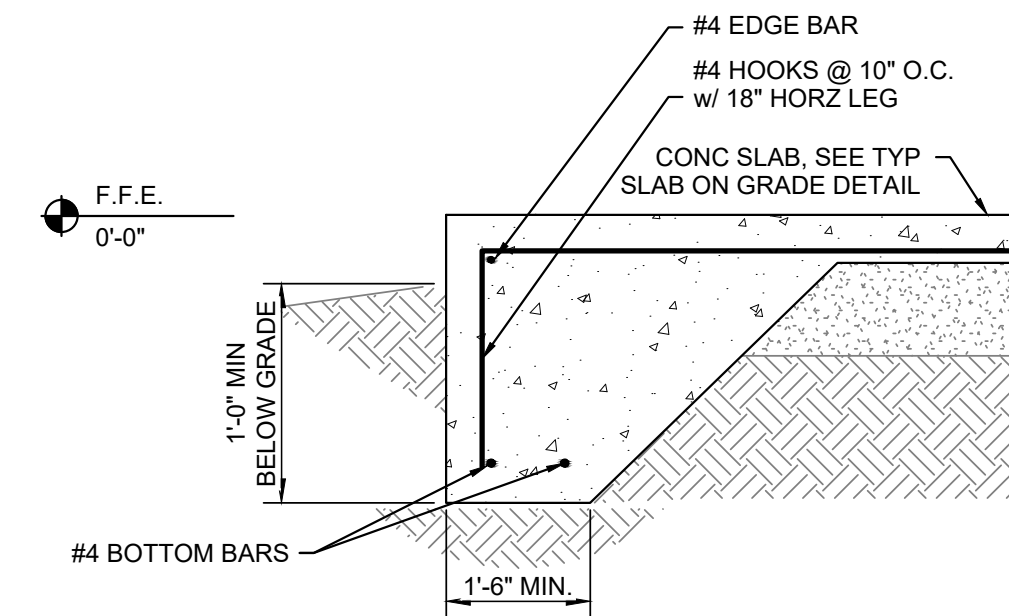

6 PERIMETER FOUNDATION  
SCALE: 3/4" = 1'-0"

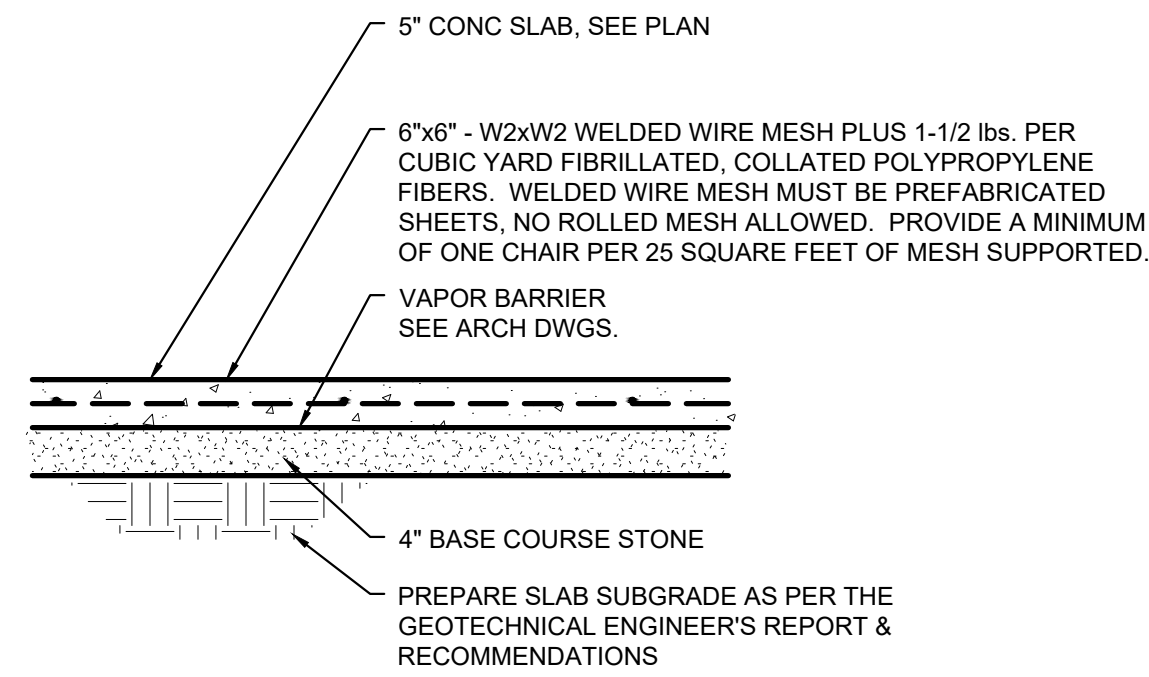

3 5" SLAB ON GRADE DETAIL  
SCALE: 3/4" = 1'-0"

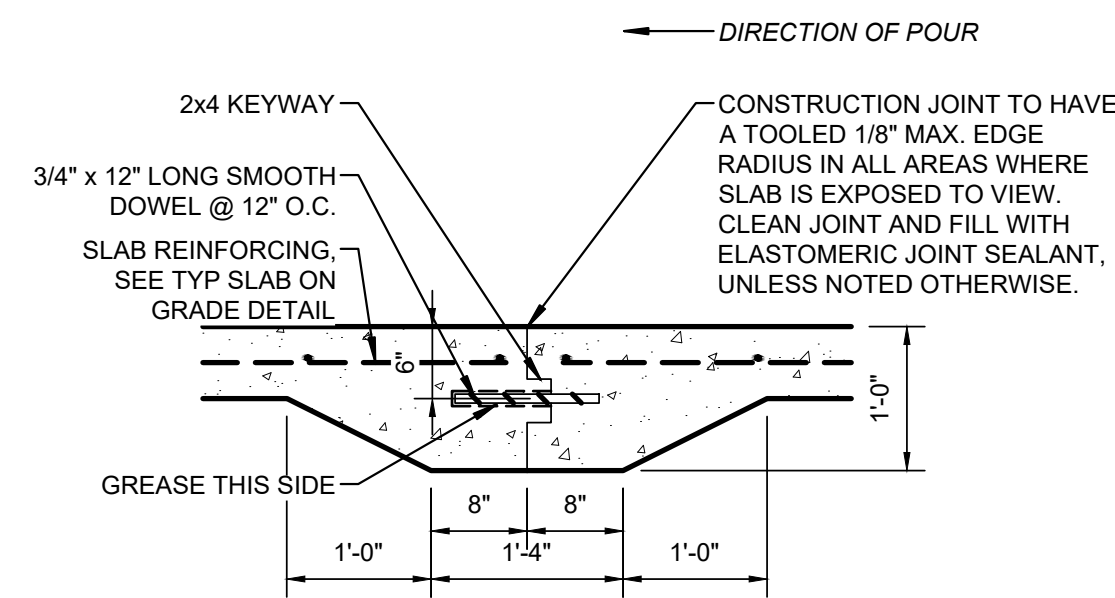

7 5" SLAB ON GRADE CONSTRUCTION JOINT  
SCALE: 3/4" = 1'-0"

- NOTES:
1. CONTRACTORS OPTION - USE REMOVABLE CONTROL JOINT MATERIAL SUCH AS "ZIP STRIP", "STRESSLOCK", OR APPROVED EQUAL.
  2. SLAB ON GRADE CONTROL JOINTS SHALL BE TOOLED OR SAWCUT. THE JOINT PATTERN SHALL BE APPROXIMATELY SQUARE AND LIMITED TO AN AREA NOT TO EXCEED 225 S.F. JOINTS SHALL BE CUT WITHIN 12 HOURS OF POURING SLAB. SEE PLAN FOR PROPOSED JOINT LAYOUT. FINAL JOINT LAYOUT TO BE DETERMINED BY THE GENERAL CONTRACTOR.

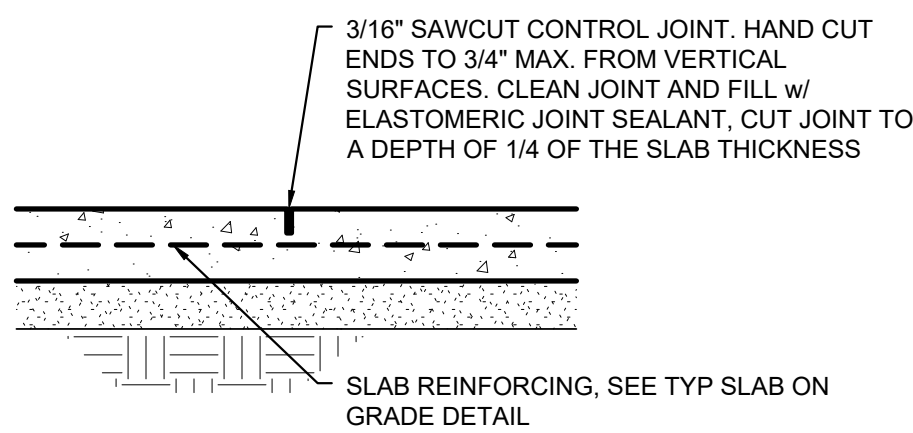

4 5" SLAB ON GRADE CONTROL JOINT  
SCALE: 3/4" = 1'-0"



DOOR SCHEDULE										
MARK	QTY.	TYPE	LOCATION	HAND	NOM. OPENING		GLAZ.	FRAME MAT.	DOOR MAT.	NOTES
					W	H				
D1	1	A	MAIN ENTRANCE	2x	72"	84"	Y	P.B.O.	P.B.O.	1 2 4 5 6
D2	2	B	SHOWROOM	LHR	36"	84"	Y	P.B.O.	P.B.O.	1 2 4 5 6
D3	2	C	WORKSHOP	LHR	36"	84"	N	P.B.O.	P.B.O.	1 2 4 5 6
D4	1	C	WORKSHOP	RHR	36"	84"	N	P.B.O.	P.B.O.	1 2 4 5 6
D7	1	D	WORKSHOP	LH	36"	84"	VWO	P.B.O.	P.B.O.	1 2 6 7 8
D8	1	C	RESTROOM	LHR	36"	84"	N	P.B.O.	P.B.O.	2 6 9
D9	1	C	RESTROOM	RH	36"	84"	N	P.B.O.	P.B.O.	2 6 9
OH1	1	---	CANOPY	OHD	16'	12'	N	P.B.O.	P.B.O.	1 4 5
OH2	2	---	WORKSHOP	OHD	14'	14'	N	P.B.O.	P.B.O.	1 4 5
OH3	1	---	WORKSHOP	OHD	14'	12'	N	P.B.O.	P.B.O.	1 4 5
OH4	1	---	INTERIOR	OHD	14'	14'	N	P.B.O.	P.B.O.	1 4 5

NOTES		
1 KEVED DEADBOLT LOCK	7 12' TOE KICK	1 INSULATED CORE CONSTR.
2 MONKEYTAIL HANDLE(S)	8 FLOOR STOP	O MOTORIZED OPENER, VWO
3 CRASH BAR PANIC HDWR	9 PRIVACY LOCK	P ENTRAPMENT PROTECTION
4 THRESHOLD & FLOOR SWEEP	T TOP & BOTTOM TRACK	M MAG FLOOR STOP
5 PERIMETER GASKET	G 2x LOW-E GLAZING	
6 CLOSER(S)		

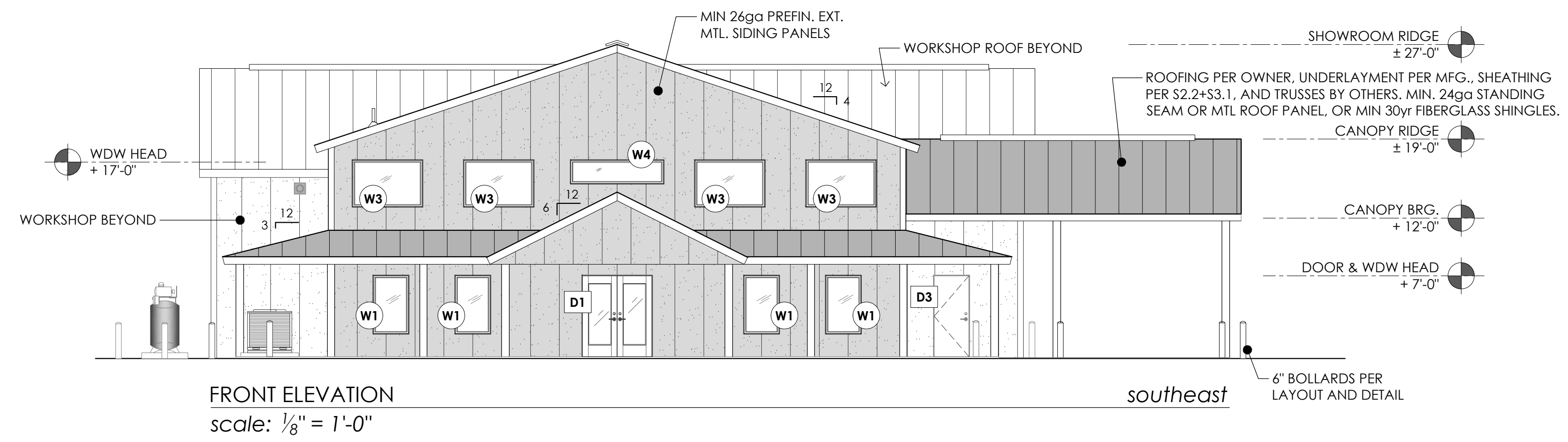

FRONT ELEVATION  
scale: 1/8" = 1'-0"

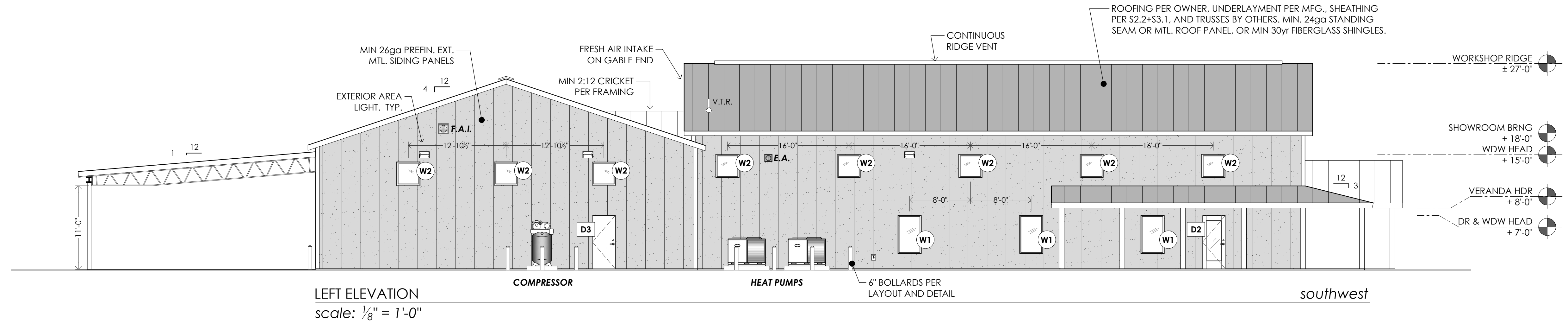

LEFT ELEVATION  
scale: 1/8" = 1'-0"

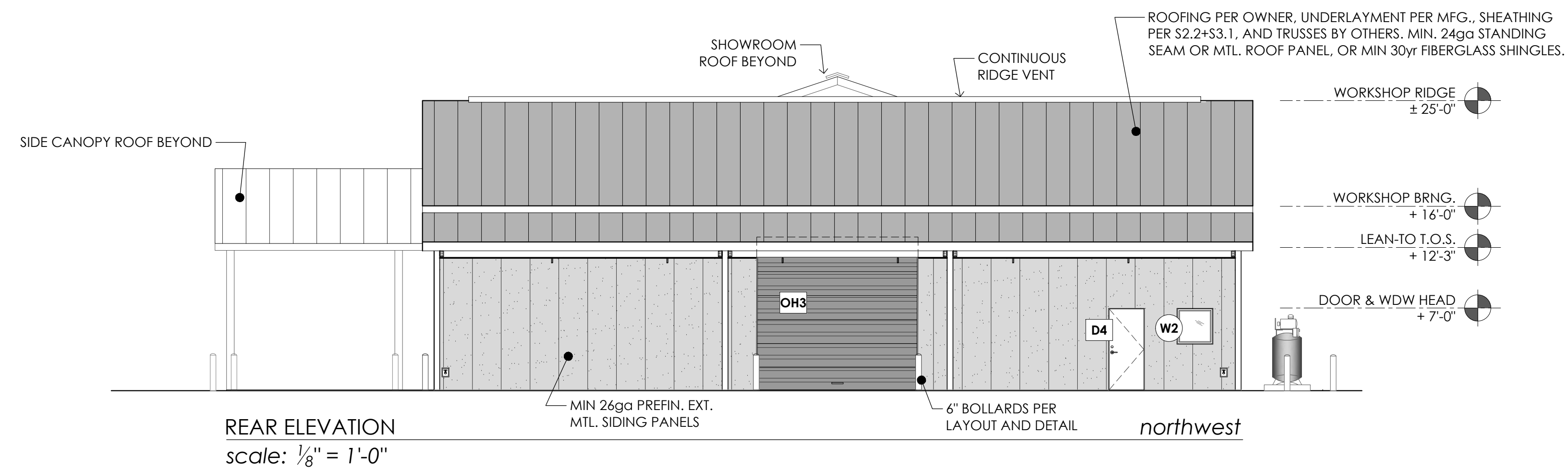

REAR ELEVATION  
scale: 1/8" = 1'-0"

WINDOW SCHEDULE											
MARK	QTY.	NOM. OPENING		SEL	HEAD	TYPE	GLAZING	OUTSIDE MAT.	INSIDE MAT.	FRAME	NOTES
		W	H								
W1	7	36"	60"	24"	84"	FIXED	V.W.O.	P.B.O.	P.B.O.	ALUM	1 3
W2	14	36"	36"	16/12	19/15	FIXED	V.W.O.	P.B.O.	P.B.O.	ALUM	1 3
W3	4	96"	48"	13'	17'	FIXED	V.W.O.	P.B.O.	P.B.O.	ALUM	1 3
W4	1	96"	24"	15'	17'	FIXED	V.W.O.	P.B.O.	P.B.O.	ALUM	1 3

NOTES		
1. INSULATED CORE	3. LOW-E INSULATED	5. CERAMIC COATING
2. INSULATED GLAZING	4. COLOR TINT	6.

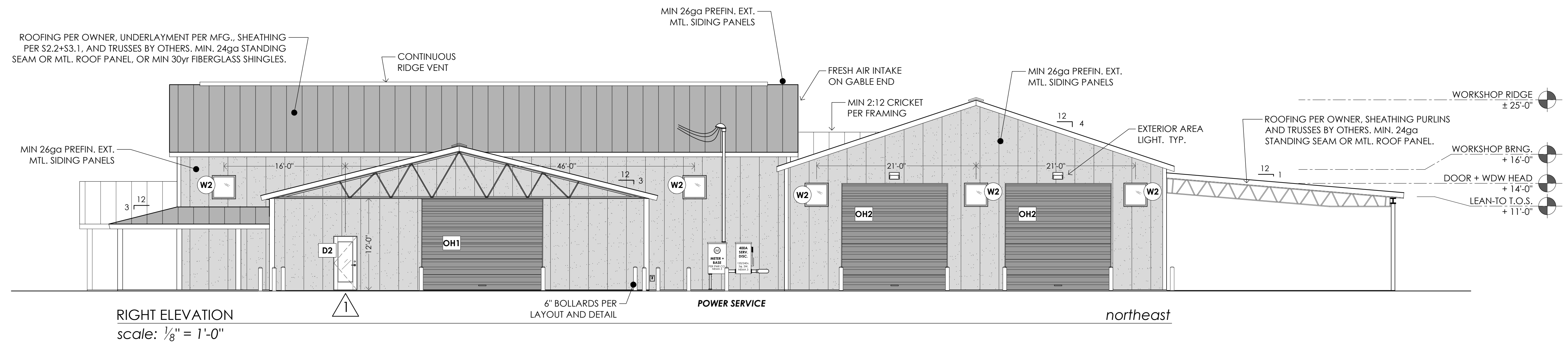

RIGHT ELEVATION  
scale: 1/8" = 1'-0"

## GENERAL MECHANICAL NOTES

### GENERAL

- ALL WORK INDICATED ON DRAWINGS/SPECIFICATIONS SHALL BE INSTALLED WITH THE LATEST REQUIREMENTS OF THE CITY, COUNTY AND STATE BUILDING CODES AND THE AUTHORITY HAVING JURISDICTION.
- BRANCH ROUND DUCTWORK LOCATED ABOVE UNACCESSIBLE CEILING OR SERVING MORE THAN ONE DIFFUSER SHALL HAVE SCOOP OMITTED, AND FACE OPERATED DAMPER IN THE DIFFUSER UNLESS NOTED OTHERWISE.
- REFER TO ARCHITECTURAL REFLECTED CEILING PLANS FOR EXACT LOCATION OF ALL CEILING MOUNTED EQUIPMENT, IF AN ITEM IS NOT SHOWN ON THE R.C.P., PREPARE A DRAWING AND SUBMIT TO THE ARCHITECT FOR APPROVAL.
- COORDINATE ALL ROOF AND SLAB PENETRATIONS WITH STRUCTURAL ENGINEER.
- TRANSITION RECTANGULAR DUCTWORK ON THE BOTTOM AND THE SIDES, MAINTAIN DUCTWORK LEVEL AND AS HIGH AS POSSIBLE UNLESS NOTED OTHERWISE.
- FLEXIBLE DUCT RUNOUTS TO DIFFUSERS SHALL BE INSTALLED FREE OF KINKS AND SAGS. ALL DIFFUSER RUNOUTS SHALL BE SIZED TO MATCH THE INLET OF THE DIFFUSER SERVED. NO FLEXIBLE DUCTS TO EXCEED 14 LINEAR FEET.
- ALL DUCT CHANGES FROM SQUARE TO ROUND SHALL BE SMOOTH TRANSITIONS, SPINNS AT THE END OF CAPPED DUCTS ARE NOT ACCEPTABLE.
- PORTIONS OF DUCTWORK OR PIPING VISIBLE THROUGH GRILLES AND REGISTERS IN FINISHED AREAS SHALL BE PAINTED FLAT BLACK.
- CONTRACTOR SHALL COORDINATE VOLTAGE AND PHASE OF EACH PIECE OF EQUIPMENT WITH THE ELECTRICAL CONTRACTOR PRIOR TO ORDERING.
- MOUNT THERMOSTATS WHERE INDICATED ON PLANS 48" ABOVE FINISHED FLOOR UNLESS NOTED OTHERWISE.
- DUCT SIZES ARE SHOWN AS INSIDE CLEAR DIMENSIONS, WHERE INTERNAL LINING IS CALLED FOR, DIMENSIONS SHALL BE INCREASED BY THE THICKNESS OF THE LINING.
- EXTEND CONDENSATE DRAIN TO NEAREST FLOOR DRAIN.
- ALL HOT WATER PIPING SHALL BE INSULATED.
- INSTALL ALL EQUIPMENT IN ACCORDANCE WITH MANUFACTURERS INSTRUCTIONS, (IE CONTROLS, REFRIGERANT SPECIALTIES ETC.)
- MECHANICAL CONTRACTOR SHALL COORDINATE ALL WORK WITH OTHER TRADES AVOID CONFLICTS.
- MECHANICAL CONTRACTOR SHALL COORDINATE DUCT ROUTING WITH STRUCTURAL BEAMS AND COLUMNS, ETC., SEE ARCHITECTURAL DRAWINGS FOR CEILING HEIGHTS DESIRED. CONTRACTOR SHALL FAMILIARIZE HIMSELF/HERSELF WITH PLANS AND PROVIDE A COMPLETE AND COORDINATED SYSTEM.
- DO NOT SCALE PLANS. PLANS ARE DIAGRAMMATIC AND SHOW THE GENERAL LOCATION OF DEVICES, EQUIPMENT, PIPE ROUTING, ETC., THE PLANS SHOW GENERAL INTENT ONLY. DUE TO THE SMALL SCALE OF PLANS, NOT ALL OFFSETS, ETC ARE SHOWN, THIS SYSTEM, SEE ARCHITECTURAL DRAWINGS FOR DIMENSIONS, WALL SECTIONS, ETC.
- MECHANICAL CONTRACTOR SHALL PROVIDE TURNING VANES IN ALL SUPPLY AIR ELBOWS AND TEES.
- SUPPLY AND RETURN AIR DUCTS SHALL BE LINED 1/2" OUT FROM THE AIR HANDLING UNIT IN BOTH DIRECTIONS. ALL OTHER DUCT SHALL BE WRAPPED. SEE SPECIFICATIONS FOR INFORMATION ON LINING AND DUCT WRAP.
- DOORS TO ALL BATHROOMS SHALL BE UNDERCUT 3/4".
- SUBMIT 4 COPIES OF PRODUCT AND CAPACITY DATA FOR SPECIFIED EQUIPMENT TO THE ARCHITECT/ENGINEER BEFORE ORDERING EQUIPMENT. IF CONTRACTOR ELECTS TO IGNORE REQUIREMENT FOR SUBMITTAL INFORMATION, OR IF SUBMITTAL IS RECEIVED AFTER INSTALLATION OF EQUIPMENT, THEN CONTRACTOR ASSUMES ALL COSTS ASSOCIATED WITH SUBSTITUTION AND RESPONSIBILITY FOR OPERATION, FUNCTION AND COORDINATION OF EQUIPMENT PURCHASED.
- IF ALTERNATE EQUIPMENT IS USED OTHER THAN WHAT IS SPECIFIED ON THE DRAWINGS, THE CONTRACTOR SHALL COORDINATE THE EQUIPMENT WITH ALL OTHER TRADES. THE COORDINATION SHALL OCCUR PRIOR TO ROUGH-IN OF ANY TRADES EQUIPMENT. ALL REVISION WORK REQUIRED TO COORDINATE ANY EQUIPMENT SUBSTITUTIONS SHALL BE PROVIDED AT NO ADDITIONAL COST TO THE OWNER.
- ALL PIPE PENETRATIONS THROUGH NON-RATED WALLS OR FLOORS SHALL BE SEALED WITH THE APPROPRIATE WALL/FLOOR MATERIALS PER THE ARCHITECTURAL SPECIFICATIONS. ALL PIPE PENETRATIONS THROUGH EXTERIOR WALLS SHALL BE SEALED WITH MATERIALS PER THE ARCHITECTURAL SPECIFICATIONS AND WATERPROOFED TO PREVENT MOISTURE FROM ENTERING THE BUILDING. ALL ROOF PENETRATIONS SHALL BE FLASHED AND MADE WATER TIGHT IN A MANNER THAT IS CONSISTENT WITH THE ROOF CONSTRUCTION AND APPROVED BY THE ROOF MATERIAL MANUFACTURER SO AS NOT TO VOID THE ROOF WARRANTY. ALL WALL, FLOOR AND ROOF PENETRATIONS AND SEALING OF PENETRATIONS SHALL BE COORDINATED WITH THE GENERAL CONTRACTOR.
- WHERE THE WORD "PROVIDE" IS USED, IT SHALL BE DEFINED TO MEAN THAT THE DEVICE/EQUIPMENT INDICATED SHALL BE FURNISHED AND INSTALLED BY THE CONTRACTOR, UNLESS OTHERWISE NOTED.
- ALL MANUFACTURERS MINIMUM WORKING CLEARANCE RECOMMENDATIONS SHALL BE MAINTAINED ON ALL EQUIPMENT.
- THE CONTRACTOR SHALL SUBMIT TO THE ARCHITECT/ENGINEER A COMPLETE SET OF AS-BUILT PLANS INDICATING ALL CHANGES ENCOUNTERED DURING CONSTRUCTION.
- THE CONTRACTOR SHALL BE RESPONSIBLE FOR OBTAINING ALL PERMITS AND SHALL NOTIFY LOCAL INSPECTION DEPARTMENTS AS WORK PROGRESSES.
- MECHANICAL CONTRACTOR SHALL INSTALL 1" PHENOLIC ID TAGS WITH LETTERING ON ALL NEW EQUIPMENT. ID TAGS ARE TO BE READABLE FROM NORMAL PERSONNEL AREAS.
- ALL NAMEPLATES AND OTHER ITEMS SHALL BE CONNECTED TO APPROPRIATE MOUNTING SURFACES SUCH THAT THEY SHALL NOT BE DETACHED DURING TRANSPORT OR OTHER OPERATING CONDITIONS. NO GLUE ON NAMEPLATES, ETC., ARE ALLOWED UNLESS APPROVED BY ENGINEER.

### PRODUCT AND EXECUTION

#### HANGERS AND SUPPORTS:

- WHERE SEVERAL PIPES RUN IN PARALLEL AND IN THE SAME PLANE, PIPES 2.5" AND SMALLER MAY BE SUPPORTED ON GANG OR MULTIPLE HANGERS, PIPES 3" AND LARGER SHALL BE SUPPORTED INDEPENDENTLY.
- COPPER PIPES SHALL BE SEPARATED FROM FERROUS SUPPORTS WITH COPPER-PLATED STEEL OR 4 psf SHEET LEAD.
- SUPPORTS FOR ALL PIPES 1.5" AND LARGER SHALL NOT BE LOCATED MORE THAN 10'-0" APART. PIPES SMALLER THAN 1.5" SHALL HAVE SUPPORTS LOCATED NOT MORE THAN 15'-0" APART. ALL PVC PIPES SHALL BE SUPPORTED AT 48" ON CENTERS.
- SUPPORT ALL PIPES INDEPENDENT OF EQUIPMENT. ADJUST HANGERS AND SUPPORTS SO THAT LOADING IS UNIFORM. ALL HANGER RODS SHALL BE SUSPENDED FROM STRUCTURE. DO NOT SUSPEND FROM OTHER PIPING, EQUIPMENT OR DUCTWORK.
- ALL DUCT HANGERS AND SUPPORTS SHALL BE IN ACCORDANCE WITH SMACNA HVAC DUCT CONSTRUCTION STANDARDS-METAL AND FLEXIBLE, 1995.

#### SLEEVES AND ESCUTCHEONS:

- PROVIDE SLEEVES WHERE PIPES PASS THRU WALLS, FLOORS AND ROOFS. ALL SLEEVES THRU OUTSIDE WALLS SHALL BE WATER TIGHT.
- SLEEVES FOR INSULATED PIPES PENETRATING NON-RATED CONSTRUCTION SHALL ALLOW FOR FULL THICKNESS OF PIPE AND INSULATION. THEY SHALL BE SIZED TO PROVIDE 3/4" CLEARANCE ON ALL SIDES OF PIPING, INCLUDING INSULATION TO ACCOMMODATE THERMAL MOVEMENT.
- PROVIDE ESCUTCHEONS WHERE PIPES PASS THRU WALLS, FLOORS AND CEILING IN FINISHED AREAS.

#### DUCTWORK:

- ALL SHEET METAL DUCTWORK, EXCEPT WHERE SPECIFIED OTHERWISE, SHALL BE FABRICATED AND INSTALLED IN ACCORDANCE WITH SMACNA STANDARDS FOR APPLICABLE PRESSURE AND CLASS. ENTIRE AIR SYSTEM INSTALLATION SHALL BE RIGID AND FREE FROM RATTLES AND AIR NOISES. INTERIOR OF DUCTS SHALL BE SMOOTH.
- FLEXIBLE DUCT SHALL BE ALLOWED FOR CONSTRUCTION OF SUPPLY AIR DIFFUSERS TO MAIN DUCT SYSTEM. FLEXIBLE DUCT LENGTH SHALL BE LIMITED TO A MAXIMUM OF 10'-0". ALL FLEXIBLE DUCT SHALL BE UL LISTED, CLASS "1", FACTORY INSULATED WITH FIBERGLASS WITH A PROTECTIVE VAPOR BARRIER JACKET TO ACHIEVE A MINIMUM R-VALUE OF 5.0 PER S.F. FT. DEG. F/BTU AT 75 DEGREES F. FLEXIBLE DUCT SHALL CONNECT TO RIGID DUCT W/ SPIN-IN FITTING AND QUADRANT DAMPER.
- PROVIDE DOUBLE THICKNESS TURNING VANES FOR ALL MITERED TURNS. PROVIDE TURNING VANES FOR ALL RADII ELBOWS LESS THAN 1.5R. VANES SHALL BE PARALLEL TO AIRFLOW AND SHALL BE BRACED AS REQUIRED TO ELIMINATE VIBRATION. PROVIDE TAPERED CONNECTIONS AT ALL BRANCH LOCATIONS.
- CONTRACTOR SHALL PROVIDE ALL TRANSITIONS REQUIRED TO CONNECT DUCT TO EQUIPMENT OR COILS. TRANSITIONS MAY VARY FROM THOSE SHOWN ON DRAWINGS, DEPENDING ON EQUIPMENT PURCHASED.

#### DAMPERS:

- MANUAL DAMPERS: MANUAL DAMPERS SHALL BE PROVIDED AT ALL MAJOR BRANCH TAKE-OFFS FROM THE MAIN DUCT AND SPECIFICALLY WHERE LOCATED ON DRAWINGS. ALL DAMPERS SHALL BE LOCATED SUCH THAT THEY CAN BE EASILY ACCESSED. DAMPERS SHALL BE SINGLE-BLADE UP TO 8" HIGH AND MULTI-BLADE OVER 8" FREE AREA WHEN IN OPEN POSITION. DAMPER BLADES SHALL BE MINIMUM OF 1/4" STEEL AND QUADRANTS SHALL BE CADMIUM-PLATED STEEL WITH DAMPER POSITION INDICATOR. PROVIDE STAND-OFF BRACKETS, SIZED TO CLEAR THE INSULATION THICKNESS, FOR QUADRANTS INSTALLED ON INSULATED DUCTWORK.

#### DIFFUSERS:

- GRILLES, REGISTER AND DIFFUSERS SHALL BE PROVIDED WITH FRAMES, BORDERS AND MOUNTING ATTACHMENTS SUITABLE FOR INSTALLATION IN ACTUAL WALL, SOFFIT OR CEILING CONSTRUCTION IN WHICH THEY ARE INSTALLED. CONTRACTOR TO COORDINATE ACTUAL INSTALLATION WITH GENERAL CONTRACTOR AND/OR ARCHITECT PRIOR TO ORDERING DIFFUSERS.
- DIFFUSERS SHALL HAVE ROUND NECKS OR SHALL BE PROVIDED WITH SQUARE-TO-ROUND COLLARS WHERE CONNECTED TO ROUND OR FLEXIBLE DUCT.

#### DUCT INSULATION:

- ALL INSULATION AND ACCESSORIES LOCATED IN A RETURN AIR PLENUM, UNLESS SPECIFICALLY EXCEPTED ON PLANS SHALL HAVE A MAXIMUM COMPOSITE FLAME SPREAD RATING OF 25 AND A MAXIMUM SMOKE DEVELOPED RATING OF 50. NO FUGITIVE OR CORROSIVE TREATMENTS SHALL BE EMPLOYED TO IMPART FLAME RESISTANCE.
- DUCT INSULATION FOR SUPPLY DUCTS AND OUTSIDE AIR DUCTS MUST BE CLOSED CELL ELASTOMERIC. FIBERGLASS DUCT LINER IS NOT PERMITTED.

#### PIPING:

- GAS PIPING: SCHEDULE 40 ASTM A53 OR A120 OR A120T4C. INSTALL PER NFPA-54.
- REFRIGERANT PIPE SHALL BE DEHYDRATED AND SEALED TYPE LACR COPPER TUBING WITH WROUGHT COPPER FITTINGS AND BRAZED OR SILVER SOLDERED JOINTS. BLEED DRY NITROGEN THROUGH TUBE WHILE SOLDERING. TEST PIPING AT 300 psig WHILE INSPECTING FOR LEAKS. SIZE, INSTALL, EVACUATE, DEHYDRATE AND CHARGE REFRIGERANT PIPING PER RECOMMENDATIONS OF AC EQUIPMENT MANUFACTURER. INSULATE SUCTION WITH 1/2" THICK INSULATION. CONFIRM REFRIGERANT PIPE SIZES WITH MANUFACTURER FOR LENGTH OF RUN PRIOR TO INSTALLATION.

#### DUCT SMOKE DETECTORS:

- DUCT SMOKE DETECTORS SHALL BE PROVIDED ON ALL SYSTEMS CAPABLE OF SUPPLYING OVER 2000 CFM, IN ACCORDANCE WITH THE LATEST ADDITION OF THE BUILDING CODE, OR AS LOCATED ON PLANS.
- IN BUILDINGS WITH A FIRE ALARM SYSTEM, DUCT SMOKE DETECTORS SHALL BE PROVIDED BY FIRE ALARM INSTALLER TO VERIFY THAT DETECTORS WILL FUNCTION WITH FIRE ALARM SYSTEM. THE MECHANICAL CONTRACTOR SHALL COORDINATE WITH THE GENERAL CONTRACTOR FOR RESPONSIBILITY TO SUPPLY DETECTORS. DETECTORS SHALL BE INSTALLED BY MECHANICAL CONTRACTOR AND WIRED BY EITHER ELECTRICAL CONTRACTOR OR FIRE ALARM CONTRACTOR. DETECTORS SHALL BE WIRED THRU FIRE ALARM SYSTEM TO SHUT HVAC UNITS DOWN IN EVENT OF SMOKE DETECTION.

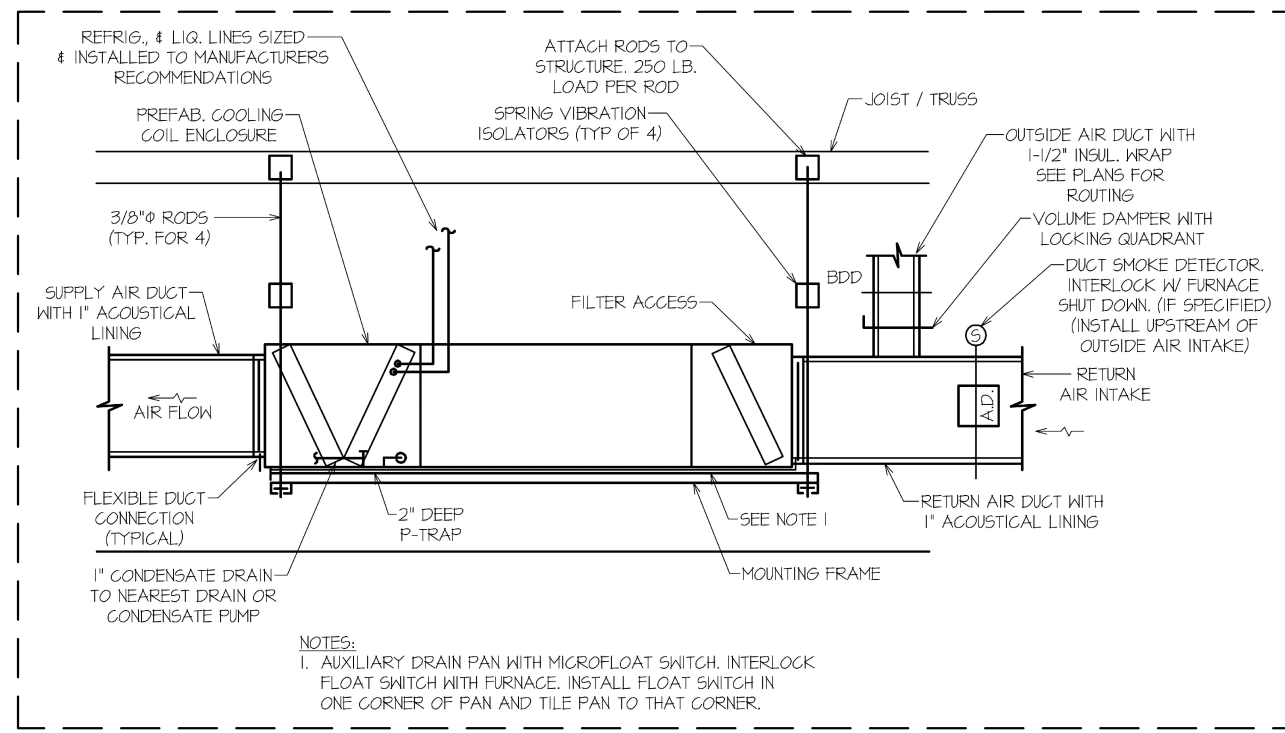

## HORIZONTAL UNIT SUPPORT

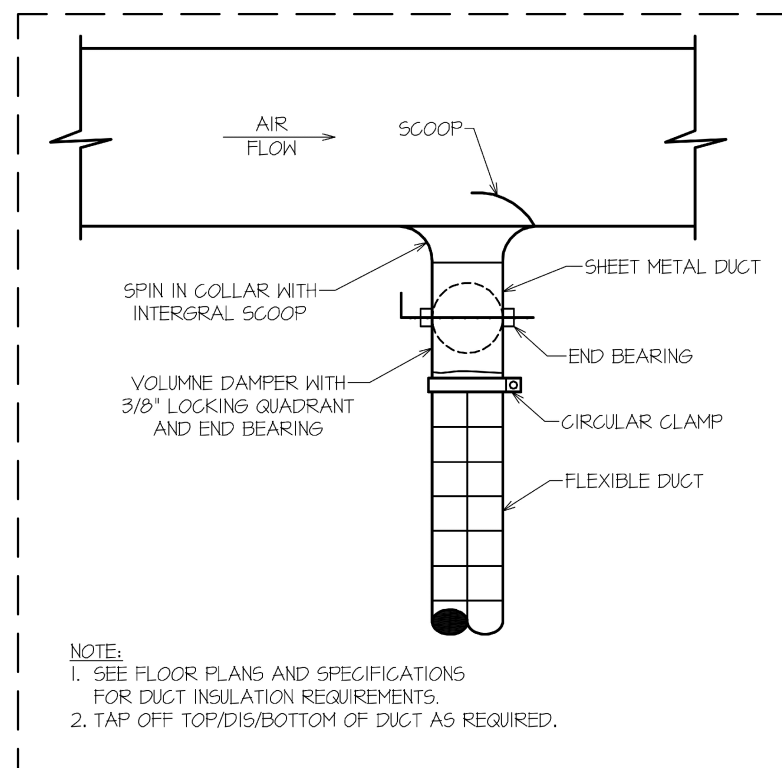
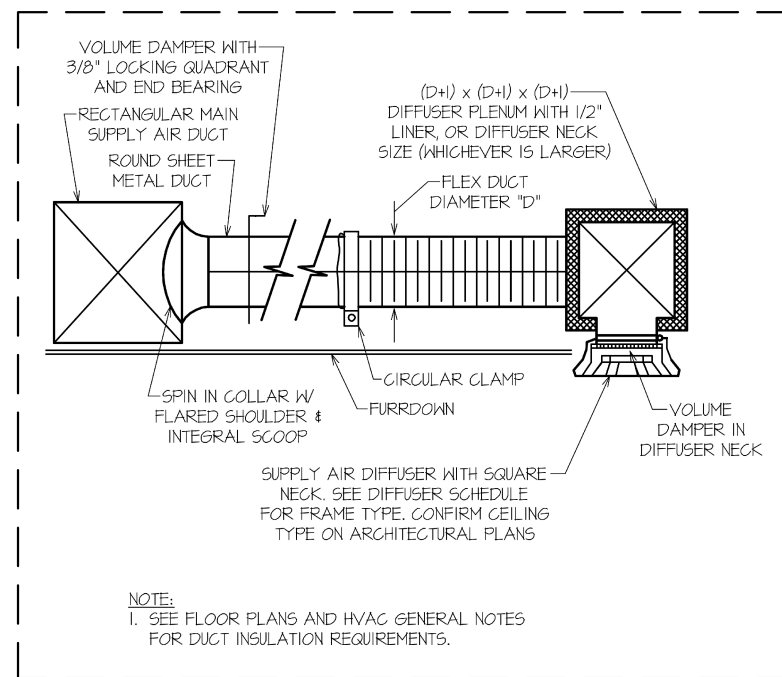

## ROUND DUCT TAKEOFF

WakeBoats		TABULATED LOADS												MINIMUM SIZING						
Area	FAI	cooling load in a Btuh	heat loss in a Btuh	heat gain in a Btuh	heat req'd in a Btuh	max. cool MBH	max. heat MBH	cool tons	heat tons	cool %	heat %	by FAI	by PAI							
October 25, 2024																				
Zone showroom	4000	240	57	79	45	12	51	32	24	34	31	20	14	20	31	70	3	7	10%	6
Zone workshop	3500	210	48	67	52	18	37	36	28	31	37	23	18	25	37	67	4	6	10%	6

REQUIRED FRESH AIR + EXHAUST TABULATION											
SHOWROOM											
area	description	s.f.	net	density calc.	actual	occ.	area rate/occ.	rate EA rate	FAI	EA	
Warehouses	showroom	4,000	-	-	-	-	-	-	0.06	-	240
Toilet rooms - public	restroom	64	-	-	-	1	1	-	-	50	
Total required fresh air intake + exhaust air										240	50

WAREHOUSE/WORKSHOP											
area	description	s.f.	net	density calc.	actual	occ.	area rate/occ.	rate EA rate	FAI	EA	
Warehouses	warehouse/workshop	3,500	-	-	-	-	-	-	0.06	-	210
Toilet rooms - public	restroom	64	-	-	-	1	1	-	-	50	
Total required fresh air intake + exhaust air										210	50

AIR HANDLER SCHEDULE															
KEY	MAKE	MODEL	NOM CFM	COOL NET	HEAT NET	FAN HP	ELECTRICAL DATA	NOTES							
AH1	CARRIER	40RFGA12A2A5	4,000	112	106	2.4	8	15	230-3	1	2	3	4	5	6

NOTES:

- ELECTRONIC SEVEN (7) DAY PROG. 15STAT
- ALL UNITS SHALL BE ASGA CERT. AND UL Labeled
- ION TYPE DETECTOR IN RETURN, SIGNAL SHUTDOWN
- 2" MERV-11, FULL SYNTHETIC MEDIA W SUPPORT, U.N.O.
- STAGED COOLING, AS AVAILABLE
- VARIABLE SPEED SUPPLY FAN MOTOR(S), AS AVAILABLE
- PHOSPHORIC MOTOR, AS AVAILABLE
- DIGITAL PHASE CONVERTER REQUIRED

HEAT PUMP + CONDENSER SCHEDULE														
KEY	MAKE	MODEL	NOM TONS	COOLING NET	HEATING NET	FAN HP	ELECTRIC	NOTES						
HP1	CARRIER	38AUGQ12	10	112	15.3	106	3.4	(2)1/2	39	50	230-3	1	2	3

NOTES:

- COOLING RATED PER ANSI STANDARD 110/20 AS RPT. A.M.S. O.D. AIR TEMP. 80°F D.B., 67°F W.B. ENTERING AIR TEMP., AND NOM. AIR QUANTITY LISTED
- REFRIG. PIPING IS TO BE SIZED PER TOTAL EQUIV. LENGTH. USE LONG-LINE KIT IF RIG. LENGTHS ARE EXCEED.
- INCL. LIQ. LINE SOLENOID VALVES, ACCUM. ETC. MAX T.E.L. IS 100'. IF DIST. CANNOT BE MET, CONTACT ENG. OR RECORD PRIOR TO INST. OF EQ.
- ALL UNITS ON SERVICE PADS OR SLAB TO RECEIVE BOTH NERVA BLOCKS AND ISOLATION PADS. UNITS SUSPENDED TO RECEIVE ISOLATION DAMPERS.

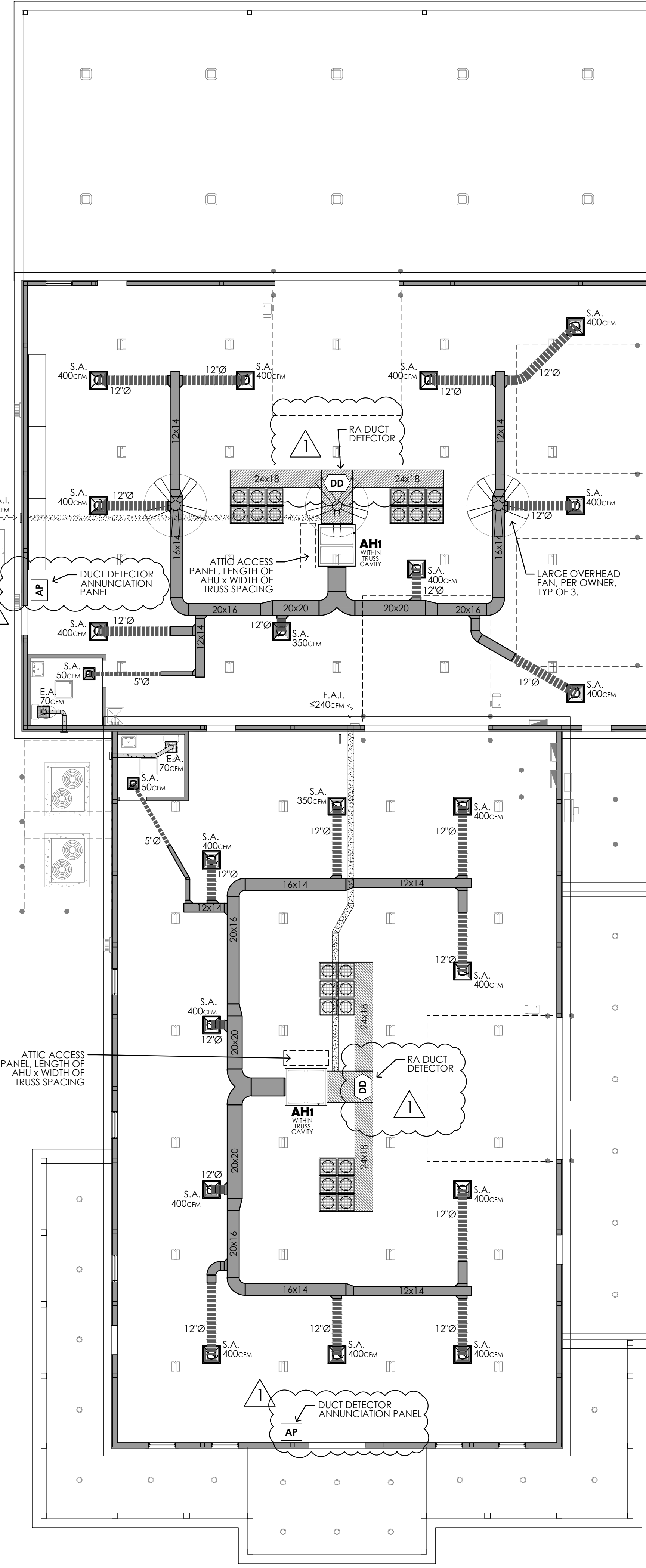

1 MECHANICAL LAYOUT scale: 1/8" = 1'-0"



INDEX	
deferred - D	11/22/2024
no changes - 0	1/23/2025
changes - 1	

MECHANICAL  
M1.0 LAYOUT, NOTES, SCHEDULES + DETAILS RLP

CONTACTS	
David Turner NC WakeBoats 143 Holly Springs Church Road Broadway, NC 27505 david@ncwakeboats.com	OWNER (919) 928-1104
Heath M. Hendrick FDR ENGINEERS 13200 Strickland Road Ste. 114 Raleigh, NC hendrick@fdr-eng.com	STRUCTURAL ENGINEER (919) 427-0501
Robert L. Pennington FDR ENGINEERS 7629 Mallow Road Wilmington, NC 28411 robertlp@fdr-eng.com	APPX B & MPE ENGINEER (910) 520-0278
Shawn Breen shawn.m.breen@gmail.com	APPX B & MPE PM (860) 387-3017

VERIFY EACH OVERHEAD DOOR TYPE WITH OWNER, SECTIONAL OR ROLLER, COORDINATE EACH WITH ROUGH OPENING, MOUNTING, LIGHTING AND OTHER FIXTURES & FITMENT, TYP OF ALL.

**FDR ENGINEERS, PLLC**  
13200 Strickland Road  
Suite # 114  
Raleigh, NC 27613  
www.fdr-eng.com  
(919) 957-5100

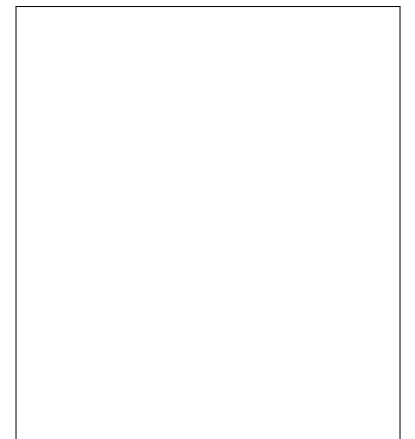
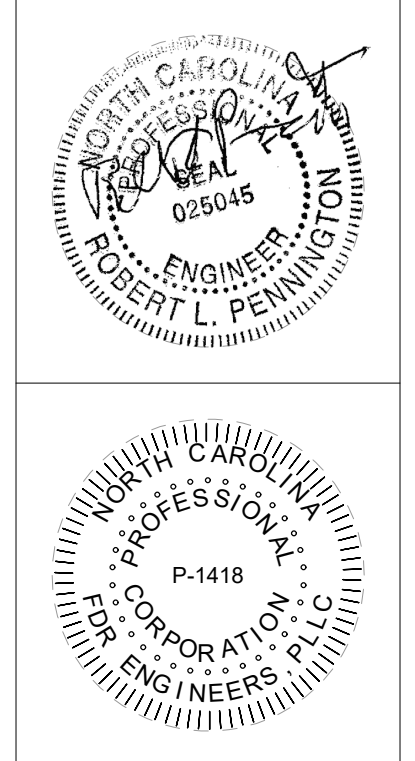

Project: 155 Holly Springs Church Road  
Broadway, NC 27505

DESIGNED BY: SMB  
DRAWN BY: SMB  
APPROVED BY: RLP  
PROJECT #: R2408270  
DATE: 2024-10-23

#	Revision	Date
0	for permit	11/08/24
1	BCO comments	01/23/25

Sheet  
**M1.0**

Ownership of Instruments of Service: All reports, plans, specifications, computer files, field data, notes and instruments prepared by the design professional as instruments of service shall remain the property of the design professional. All common law, statutory and other reserved rights including the copyright thereof.

## PLUMBING NOTES

- ALL PLUMBING SHALL BE INSTALLED IN ACCORDANCE WITH THE LATEST ISSUE OF THE NATIONAL STANDARD PLUMBING CODE, THE NATIONAL FIRE CODE, AND ALL OTHER APPLICABLE CODES.
- ALL PLUMBING PIPING SHALL BE CLOSELY COORDINATED WITH STRUCTURAL SYSTEM, MECHANICAL SYSTEM AND ELECTRICAL SYSTEM TO INSURE PROPER COMPLIANCE WITH CODES AND INSURE THAT ALL TRADES WILL NOT CONFLICT WITH EACH OTHER.
- ALL SANITARY SEWER PIPING RUN BELOW GROUND OR FIRST FLOOR SLAB SHALL BE RUN AT 1/8" FT. PITCH UNLESS OTHERWISE REQUIRED BY CODE OR NOTED.
- ALL WATER PIPING SHALL BE PITCHED FOR DRAINAGE WITH DRAIN VALVES INSTALLED AT LOW POINT AND MANUAL AIR VALVES INSTALLED AT HIGH POINTS WHERE REQUIRED.
- PROVIDE ACCESS PANELS AS REQUIRED AT VALVE LOCATIONS TO PROVIDE ACCESS. COORDINATE TYPE AND LOCATION WITH GENERAL CONTRACTOR.
- ALL CLEANOUTS SHALL HAVE TOPS ESPECIALLY DESIGNED FOR PERTINENT FLOOR FINISHES SUCH AS CARPET, TILE, ETC. UNLESS OTHERWISE SPECIFIED.
- DO NOT SCALE DRAWINGS. SEE ARCHITECTURAL DRAWINGS FOR EXACT LOCATIONS OF DOORS, WINDOWS, WALLS, FIXTURES, ETC. AS REQUIRED.
- EXCEPT WHERE PIPE SPACE IS PROVIDED OR UNLESS OTHERWISE NOTED, ALL SUPPLY, WASTE AND VENT RISERS SHALL BE RUN IN WALLS AND PARTITIONS.
- VENTS WILL BE COLLECTED ABOVE THE CEILING AND EXTENDED THROUGH THE ROOF AS A SINGLE VENT AT THE POINTS INDICATED.
- P.C. SHALL PROVIDE A PRESSURE REDUCING VALVE WHERE WATER MAIN ENTERS BUILDING IF PRESSURE EXCEEDS 80 PSI.
- ALL MATERIALS AND THEIR INSTALLATIONS SHALL COMPLY WITH THE STATE AND LOCAL CODES, RULES, REGULATIONS, AND ORDINANCES.
- PIPING:
  - FURNISH AND INSTALL DIELECTRIC OR ISOLATION FITTINGS AT ALL POINTS WHERE COPPER PIPE CONNECTS TO WROUGHT IRON OR STEEL PIPE.
  - EXPOSED PIPE IN TOILET ROOMS: CHROME PLATED BRASS, AMERICAN BRASS COMPANY, OR EQUIVALENT. FURNISH AND INSTALL CHROME WALL PLATES.
  - PIPING UNDER FLOOR SLAB SHALL BE TYPE "K" SOFT TEMPER COPPER TUBING ASTM B-88 NO JOINTS SHALL BE PERMITTED UNDER FLOOR SLAB. ALL JOINTS UNDER GROUND SHALL BE MECHANICALLY CLEANED BEFORE BRAZING AND PASTE FLUX APPLIED.
  - PIPING ABOVE FLOOR SLAB SHALL BE TYPE "L" HARD DRAWN COPPER TUBING ASTM B-88 USE WROUGHT COPPER SWEAT FITTINGS. ALL JOINTS SHALL BE MADE WITH LEAD-FREE SOLDER AND PASTE FLUX AND MECHANICALLY CLEANED BEFORE SOLDERING.
  - PROVIDE PDI APPROVED WATER HAMMER ARRESTERS IN THE PIPING AS MAY BE REQUIRED TO ACCOMPLISH NOISELESS OPERATION OF THE SYSTEM UNDER ALL OPERATING CONDITIONS. PROVIDE ACCESS PANELS OF REQUIRED SIZES AND TYPES AS TO ACCESS ALL CLEANOUTS, VALVES, TRAPS, WATER HAMMER ARRESTERS, ETC. ACCESS PANELS AND COVERS SHALL BE APPROVED BY THE ARCHITECT OR OWNER.
  - SANITARY WASTE, AND VENT PIPING: PIPING SHALL BE SCHEDULE 40 PVC-DWV PIPE AND FITTINGS. PIPING IN EXPOSED AREAS SUCH AS LAVATORY P-TRAPS SHALL BE CHROME-PLATED BRASS. INTERIOR CONDENSATE DRAIN PIPING RUNNING HORIZONTAL SHALL BE INSULATED WITH 5/8" THICK ARMAFLEX. PLUMBING CONTRACTOR SHALL RUN ALL BUILDING CONDENSATE DRAINS.
- WATER SUPPLY AND WASTE WATER PIPING SHALL BE KEPT A MINIMUM OF TEN (10) FEET APART. WHEN PIPES CROSS OR COME CLOSER THAN TEN FEET FRESH WATER PIPING SHALL BE 16" ABOVE THE CROWN OF SANITARY PIPING.
- DRAWINGS AND RISERS ARE DIAGRAMMATICAL AND ARE NOT INTENDED TO SHOW REQUIRED FITTINGS AND OFFSETS REQUIRED FOR ACTUAL INSTALLATION.
- ALL HOSE BIBBS SHALL BE FREEZE PROOF AND PROVIDED WITH A NON-REMOVABLE VACUUM BREAKER.
- PIPE PENETRATIONS THROUGH FIRE RATED ASSEMBLIES SHALL BE IN METAL SLEEVES. ANNULAR SPACES BETWEEN SLEEVES AND PIPES SHALL BE SEALED AS REQUIRED BY THE LOCAL AUTHORITY.
- DIELECTRIC CONNECTIONS SHALL BE USED BETWEEN FERROUS AND NON-FERROUS PIPING.
- WATER HEATER SHALL BE FILLED WITH WATER AND PURGED AS SOON AS INSTALLED OR IN NO EXTENT LATER THAN GAS/ELECTRIC HOOK-UP. FURNISH A ONE YEAR MANUFACTURERS WARRANTY.
- CONTRACTOR SHALL FURNISH OWNER WITH SAMPLES OF FIXTURES FOR APPROVAL.
- SLIP JOINTS SHALL NOT BE USED FOR DRAIN CONNECTIONS IN CONCEALED LOCATIONS. USE SOLDERED OR SCREWED JOINTS ONLY.
- ALL FIXTURES SHALL BE COMPLETE AND INCLUDE ALL STOPS, VALVES, FAUCETS, DRAINS, TRAPS, TAIL PIECES, ESCUTCHEONS, AND SUPPLIES.
- PROVIDE CLEANOUTS AT THE BASE OF ALL WASTE STACKS, AT ALL CHANGES OF DIRECTION OF PIPING IN EXCESS OF 45° AND EVERY 50 FEET.
- ALL PIPING SHALL BE TESTED IN ACCORDANCE WITH INDUSTRY STANDARDS AND DOMESTIC WATER SHALL BE IN COMPLIANCE WITH CITY STANDARDS.
- ALL PIPING SHALL BE RUN IN AREAS NOT SUBJECT TO FREEZING TEMPERATURES. PIPING IN EXTERIOR WALLS SHALL BE INSULATED AND RUN ON THE CONDITIONED SIDE OF THE WALL INSULATION.
- PIPE PENETRATIONS OF RATED WALLS SHALL BE FIRE STOPPED AS NECESSARY TO MAINTAIN THE RATING OF THE WALL.
- VENT PIPES SHALL BE COMBINED SO THAT NO MORE THAN ONE ROOF PENETRATION PER UNIT STACK WILL BE REQUIRED, UNLESS APPROVED BY THE OWNER.
- BACKFLOW PREVENTERS SHALL BE INSTALLED IN EACH MAIN SUPPLY LINE TO BUILDINGS.

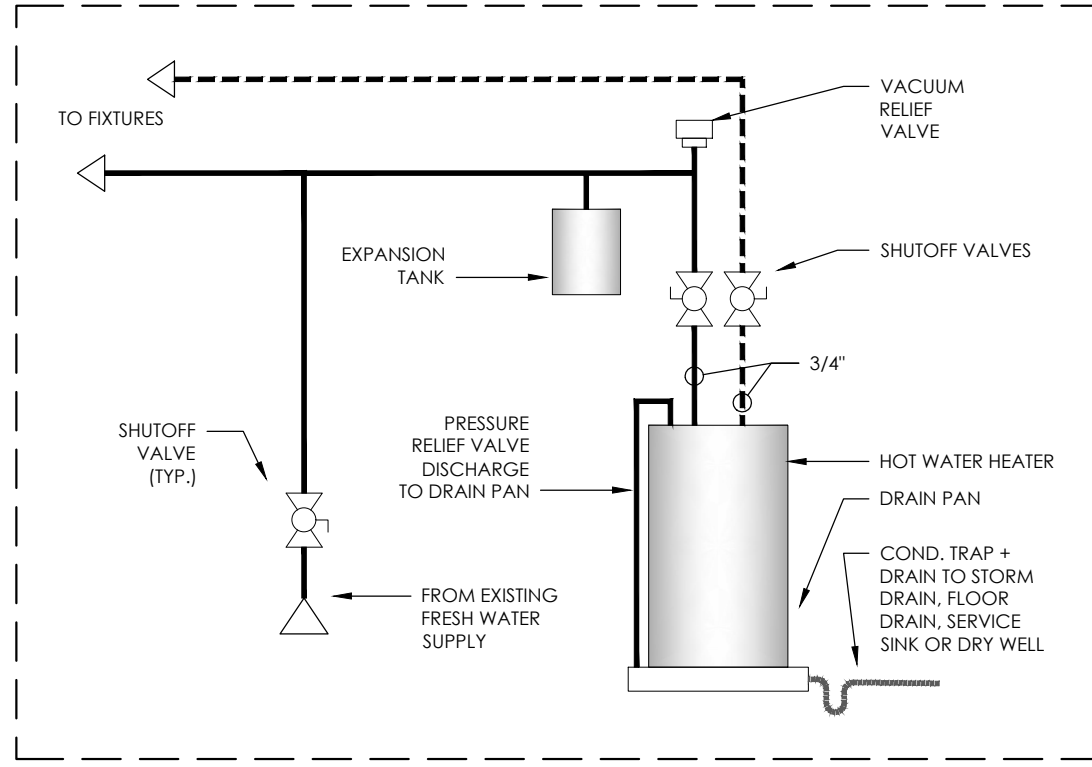

WATER HEATER TYPICAL INSTALLATION

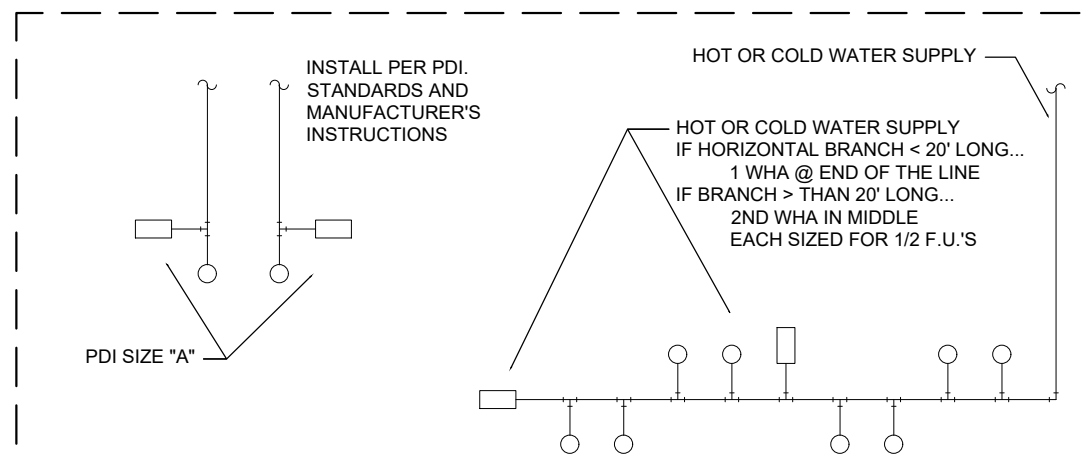

### SINGLE FIXTURE

PDI SIZE	PIPE SIZE	FIXTURE UNIT LOAD
A	1/2"	1 - 11
B	3/4"	12 - 32
C	1"	33 - 60
D	1-1/4"	61 - 113
E	1-1/2"	114 - 154
F	2"	155 - 330

### MULTIPLE FIXTURES

FIXTURE	COLD	HOT
VALVE WATER CLOSET	10	--
URINAL	5	--
SERVICE SINK	2.25	2.25
3 COMP SINK	2	2.0
LAVATORY / SINK	1.5	1.5
DRINKING FOUNTAIN	0.25	--

PLUMBING CONTRACTOR TO PROVIDE AIR CHAMBERS OR WATER HAMMER ARRESTERS BY SLOUX CHIEF, PRECISION PLUMBING PRODUCTS, WATTS OR APPROVED EQUIVALENT WITH PISTON O-RING CONSTRUCTION, HAVING ASSE # 1010 AND ANSI #A12.26.1M CERTIFICATION. INSTALL IN HORIZONTAL OR VERTICAL POSITION, BUT NEVER UPSIDE DOWN. INSTALL IN LINE WITH WATER FLOW DIRECTION IF POSSIBLE. SIZE THE UNITS AS SHOWN ON THE DRAWINGS AND / OR PER THE TABLES SHOWN ABOVE.

WATER HAMMER ARRESTOR SCHEDULE

### DESIGN PARAMETERS NOTE:

- THE PLUMBING SUPPLY SYSTEM HAS BEEN DESIGNED IN ACCORDANCE WITH **NSPC TABLE B.7.3.B TYPE K COPPER TUBING**. C.C. TO VERIFY ADEQUATE PRESSURE AND EXISTING CONDITIONS AND PROVIDE ANY ADDITIONAL APPURTANCES AS REQUIRED TO ACHIEVE A SATISFACTORY FUNCTIONING AND COMPLIANT SYSTEM.
- ALL RESTROOM LAVATORIES HAND SINKS TO RECEIVE 120° HOT WATER SUPPLIED BY ABOVE CEILING MIXING VALVE.
- INSTALL TRAP PRIMERS AS REQUIRED BY CURRENT **N.S.P.C.** AND ALL OTHER APPLICABLE CODES.
- ALL FIXTURE SUPPLY CONNECTIONS TO HAVE ACCESSIBLE MANUAL BALL TYPE SHUTOFF VALVES OR ACCESS PANEL TO SAME.
- REFER TO **N.S.P.C.** AND MANUF. SPECIFICATIONS FOR ALL SUPPLY, INLET, TRAP, AND DRAIN SIZES.
- ALL VENTING TO COMPLY WITH THE CURRENT **N.S.P.C.**

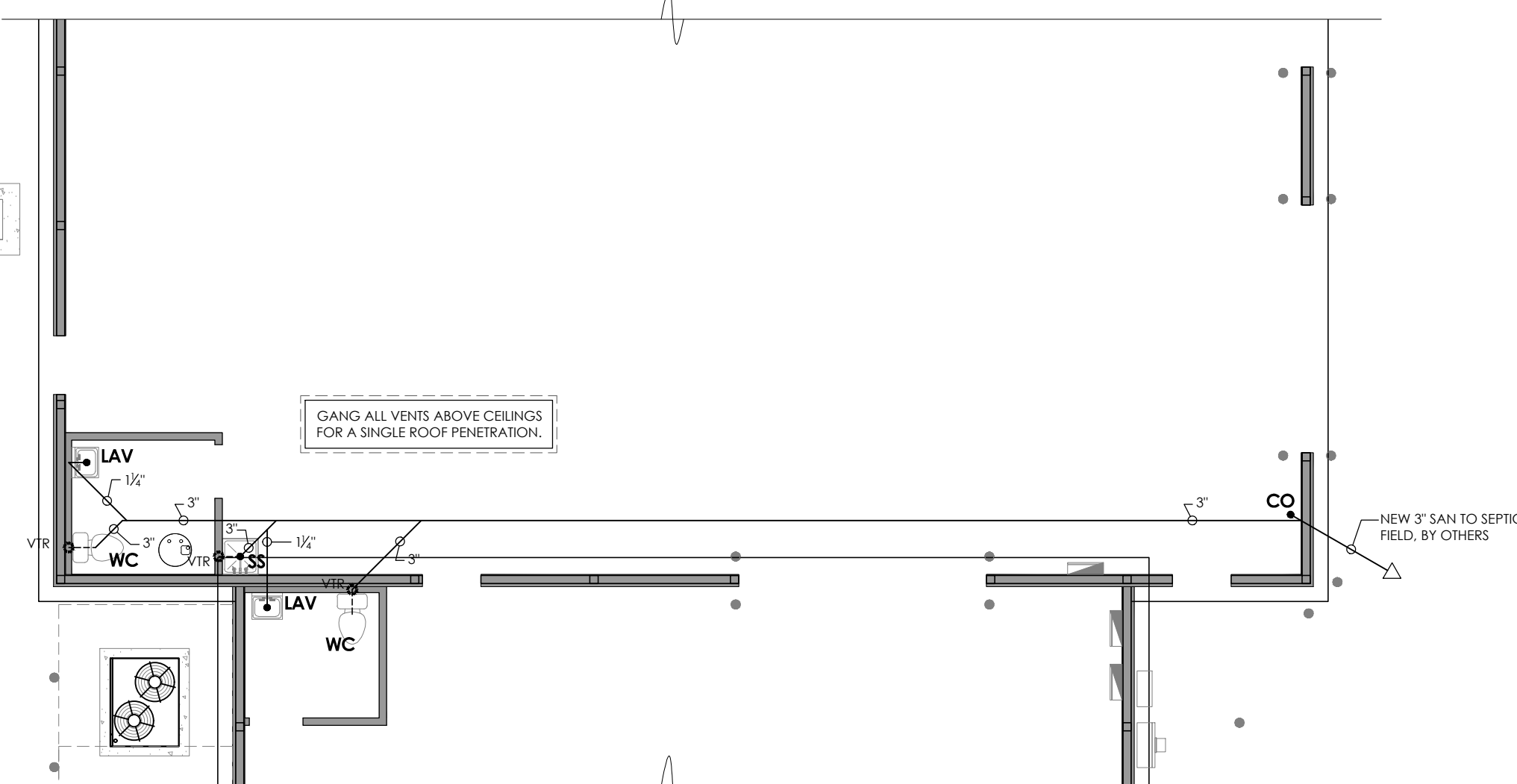

2 PARTIAL SANITARY LAYOUT  
scale: 1/8" = 1'-0"

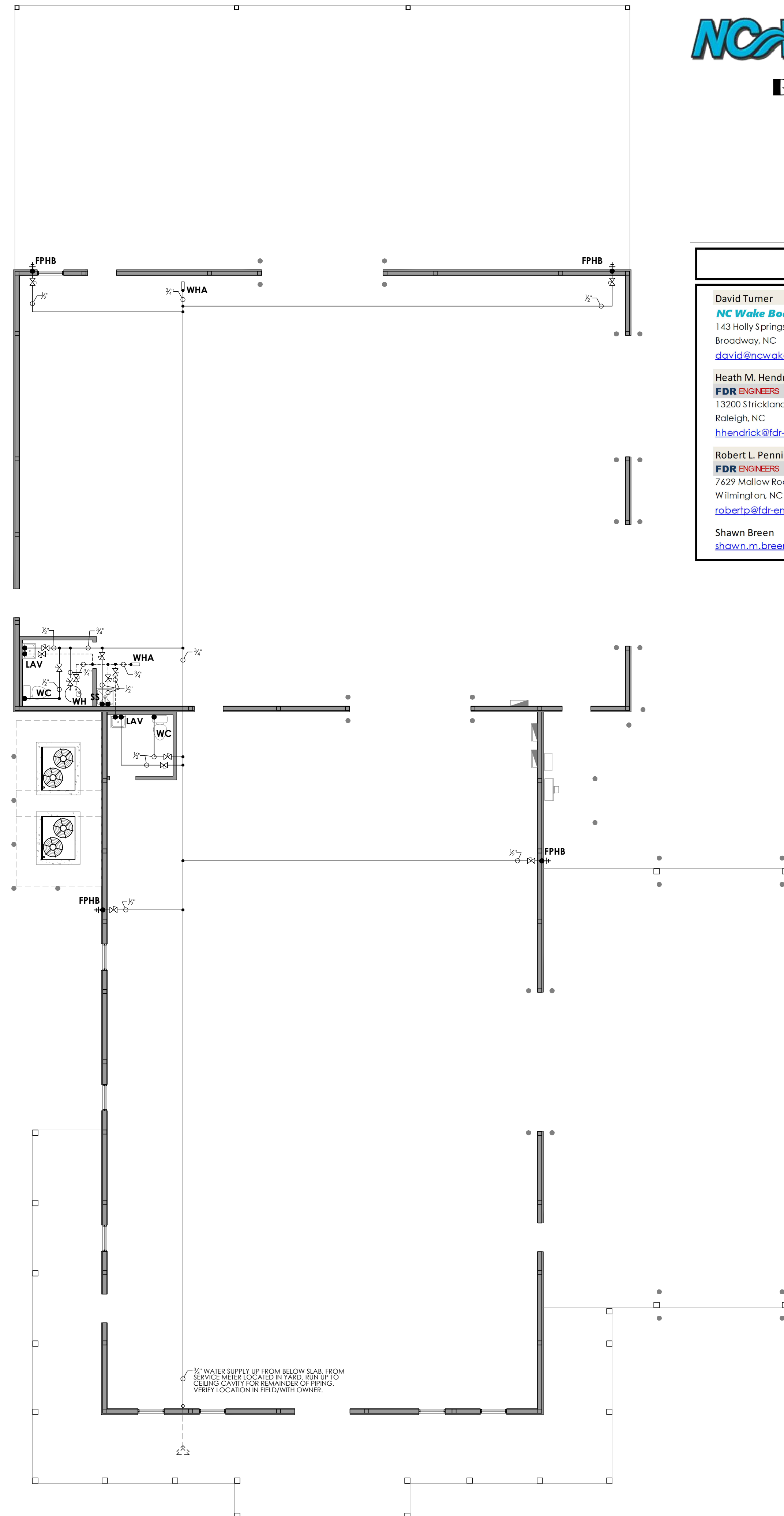

1 FW SUPPLY LAYOUT  
scale: 1/8" = 1'-0"

**NC WakeBoats**  
Broadway, NC

## CONTACTS

Name	Role	Contact Info
David Turner	OWNER	(919) 928-1104
Heath M. Hendrick	STRUCTURAL ENGINEER	(919) 427-0501
Robert L. Pennington	APPX B & MPE ENGINEER	(910) 520-0278
Shawn Breen	APPX B & MPE PM	(860) 387-3017

**FDR Engineers, PLLC**  
13200 Strickland Road  
Suite #111  
Raleigh, NC 27613  
www.fdr-eng.com  
(919) 957-5100

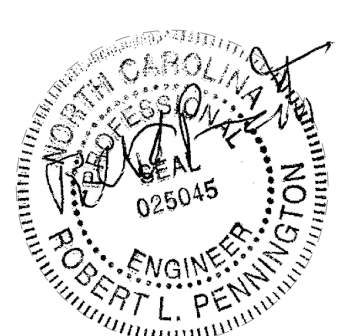

**NC WakeBoats**  
155 Holly Springs Church Road  
Broadway, NC 27505

DESIGNED BY: SMB  
DRAWN BY: SMB  
APPROVED BY: RLP  
PROJECT #: R2408270  
DATE: 2024-10-23

#	Revision	Date
0	for permit	11/8/24

Sheet

**P1.0**

## GENERAL ELECTRICAL NOTES

- PERFORM ALL WORK IN ACCORDANCE WITH THE LATEST EDITION OF THE NATIONAL ELECTRICAL CODE (NEC) AND ALL OTHER APPLICABLE STATE AND LOCAL CODES.
- THE ELECTRICAL DRAWINGS ARE DIAGRAMMATIC ONLY. REFER TO ARCHITECTURAL DRAWINGS FOR BUILDING DIMENSIONS. REFER TO MECHANICAL AND PLUMBING DRAWINGS FOR EXACT EQUIPMENT LOCATIONS.
- FURNISH ALL LABOR, MATERIALS, SERVICES AND SKILLED SUPERVISION NECESSARY FOR THE INSTALLATION, TESTING, AND ADJUSTMENT OF ALL CIRCUITING AND ELECTRICAL EQUIPMENT SPECIFIED HEREIN, OR SHOWN OR NOTED ON THE DRAWINGS AND ITS DELIVERY TO THE BUILDING OWNER COMPLETE AND READY FOR USE. ALL ELECTRICAL WORK SHALL BE NEW EXCEPT WHERE SPECIFICALLY NOTED OTHERWISE ON THE DRAWINGS.
- THE CONTRACTOR SHALL CAREFULLY EXAMINE THE SITE AND SHALL COMPARE THE DRAWINGS WITH THE EXISTING ELECTRICAL INSTALLATION AND SHALL THOROUGHLY FAMILIARIZE HIMSELF WITH ALL EXISTING CONDITIONS WITH THE SCOPE OF THIS PROJECT.
- ARRANGE WORK SO THAT ELECTRICAL POWER AND COMMUNICATIONS ARE AVAILABLE TO EXISTING FACILITIES WITHIN THE BUILDING WHICH ARE TO REMAIN AT ALL TIMES DURING CONSTRUCTION. THE CONTRACTOR SHALL SCHEDULE ALL INTERRUPTIONS AT THE CONVENIENCE OF THE BUILDING OWNER AND TENANT.
- MATERIALS AND EQUIPMENT SHALL CONFORM TO AND BE IN ACCORDANCE WITH THE LATEST APPLICABLE STANDARDS OF THE NATIONAL ELECTRICAL MANUFACTURERS ASSOCIATION (NEMA) AND THE AMERICAN STANDARDS INSTITUTE (ANSI), WHERE STANDARDS HAVE BEEN ESTABLISHED FOR SPECIFIC ITEMS, AND EQUIPMENT AND INSPECTION CATEGORIES HAVE BEEN ESTABLISHED BY THE UNDERWRITERS' LABORATORY, THE MATERIALS AND EQUIPMENT SHALL BE LISTED AND BEAR THE UL LABEL.
- ELECTRICAL EQUIPMENT AND FIXTURES SHALL BE CONNECTED TO PROVIDE CIRCUIT CONTINUITY IN ACCORDANCE WITH APPLICABLE CODES WHETHER OR NOT EACH PIECE OF CONDUCTOR, CONDUIT, OR PROTECTIVE DEVICES ARE SHOWN BETWEEN EQUIPMENT AND FIXTURES AND POINT OF CIRCUIT ORIGIN.
- REMOVE ALL ELECTRICAL EQUIPMENT AND MATERIALS IN AREAS TO BE DEMOLISHED UNDER SCOPE OF WORK FOR THIS PROJECT. EXTEND, REVISE AND/OR CORRECT EXISTING CIRCUITING AFFECTED BY DEMOLITION WORK AS REQUIRED AND AS NOTED ON THE DRAWINGS. ALL EXISTING ELECTRICAL EQUIPMENT, FIXTURES, ETC., NOT SPECIFICALLY DESIGNATED FOR REMOVAL ON THE DRAWINGS SHALL REMAIN.
- THE CONTRACTOR SHALL RELABEL ALL REVISED BRANCH CIRCUITS, PANEL BOARD DESIGNATIONS, ETC., BASED ON THE SCOPE OF WORK FOR THIS PROJECT AND SHALL UPDATE PANELBOARD DIRECTORIES ACCORDINGLY - FINAL DIRECTORIES TO BE TYPED.
- THE CONTRACTOR SHALL COORDINATE THE MOUNTING HEIGHTS OF ALL WALL MOUNTED ELECTRICAL AND TELECOMMUNICATIONS DEVICES WITH ARCHITECTURAL DRAWINGS AND DETAILS PRIOR TO INSTALLATION.
- THE CONTRACTOR SHALL VERIFY ALL DOOR SWINGS WITH ARCHITECTURAL DRAWINGS PRIOR TO INSTALLATION OF WALL SWITCHES. WALL SWITCHES SHALL BE LOCATED ON LOCK SIDE OF ALL DOORS UNLESS PHYSICALLY IMPOSSIBLE TO INSTALL IN THIS LOCATION OR INDICATED OTHERWISE ON DRAWINGS. VERIFY LOCATIONS OF WALL SWITCHES WITH ARCHITECT IN EVENT OF CONFLICTS!
- MULTIPLE WALL SWITCHES SHOWN IN ONE LOCATION ON DRAWINGS SHALL BE GANGED UNDER A COMMON COVERPLATE UNLESS OTHERWISE NOTED ON DRAWINGS. GANGING OF SWITCHES SHALL MEET ALL REQUIREMENTS OF THE LATEST EDITION OF THE NATIONAL ELECTRICAL CODE (NEC).
- CEILING GRID LAYOUTS WHERE SHOWN ON ELECTRICAL DRAWINGS ARE FOR INFORMATION ONLY. CONTRACTOR SHALL COORDINATE THE PLACEMENT AND MOUNTING HARDWARE REQUIREMENTS OF ALL LIGHTING FIXTURES IN ACCORDANCE WITH ARCHITECTURAL REFLECTED CEILING PLANS AND MECHANICAL/PLUMBING PLANS PRIOR TO INSTALLATION OF DEVICES.
- FURNITURE LAYOUTS WHERE SHOWN ON ELECTRICAL DRAWING ARE FOR INFORMATION ONLY. CONTRACTORS SHALL COORDINATE THE LOCATIONS OF ALL DEVICES WITH ARCHITECTURAL DRAWINGS AND DETAILS, AND ELECTRICAL DRAWINGS PRIOR TO INSTALLATION OF DEVICES.
- ALL WORK ASSOCIATED WITH ADDITIONS OR REVISIONS TO BASE BUILDING FIRE ALARM SYSTEM SHALL BE COORDINATED WITH BUILDING OWNER PRIOR TO START OF CONSTRUCTION.
- ALL AUDIO-VISUAL EQUIPMENT AND ASSOCIATED CABLING TO BE PROVIDED AND INSTALLED BY A/V EQUIPMENT SUPPLIER/INSTALLER. CONTRACTOR SHALL COORDINATE ALL A/V WORK WITH A/V CONSULTANT PRIOR TO START OF CONSTRUCTION.
- ALL WORK ASSOCIATED WITH TELECOMMUNICATIONS OR COMPUTER EQUIPMENT SHALL BE COORDINATED WITH THE BUILDING OWNER AND THE TELECOMMUNICATIONS EQUIPMENT/CABLING INSTALLER PRIOR TO START OF CONSTRUCTION.

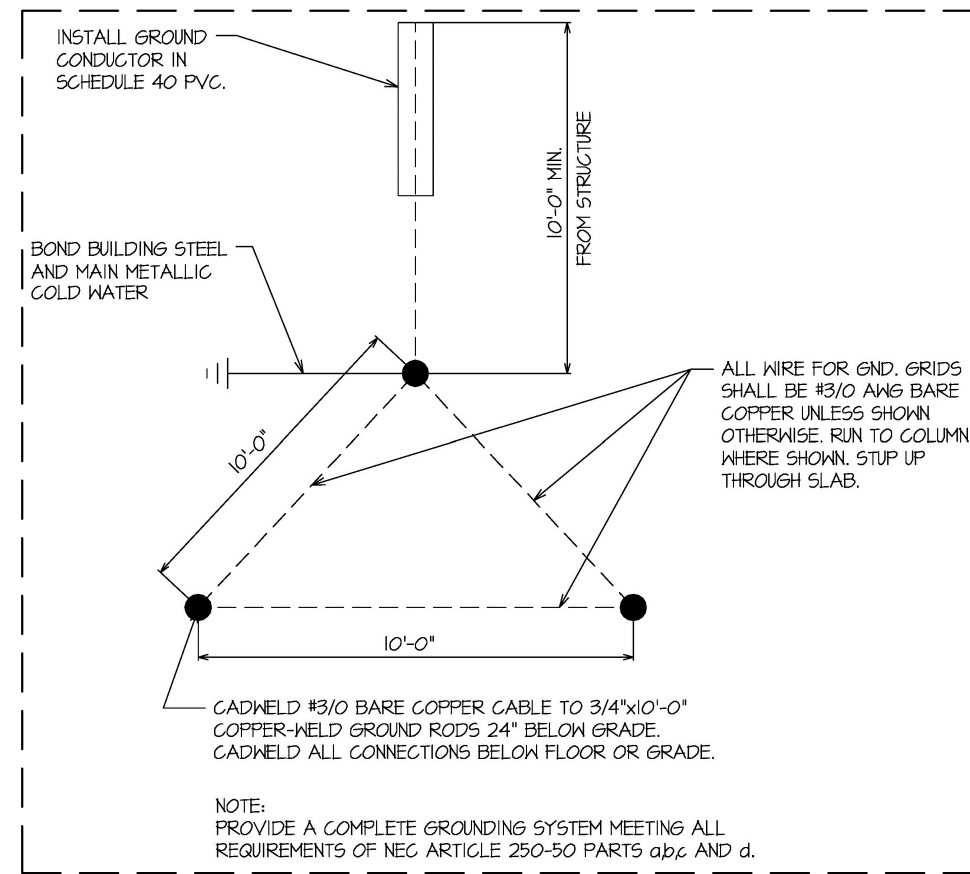

POWER SERVICE GROUNDING GRID

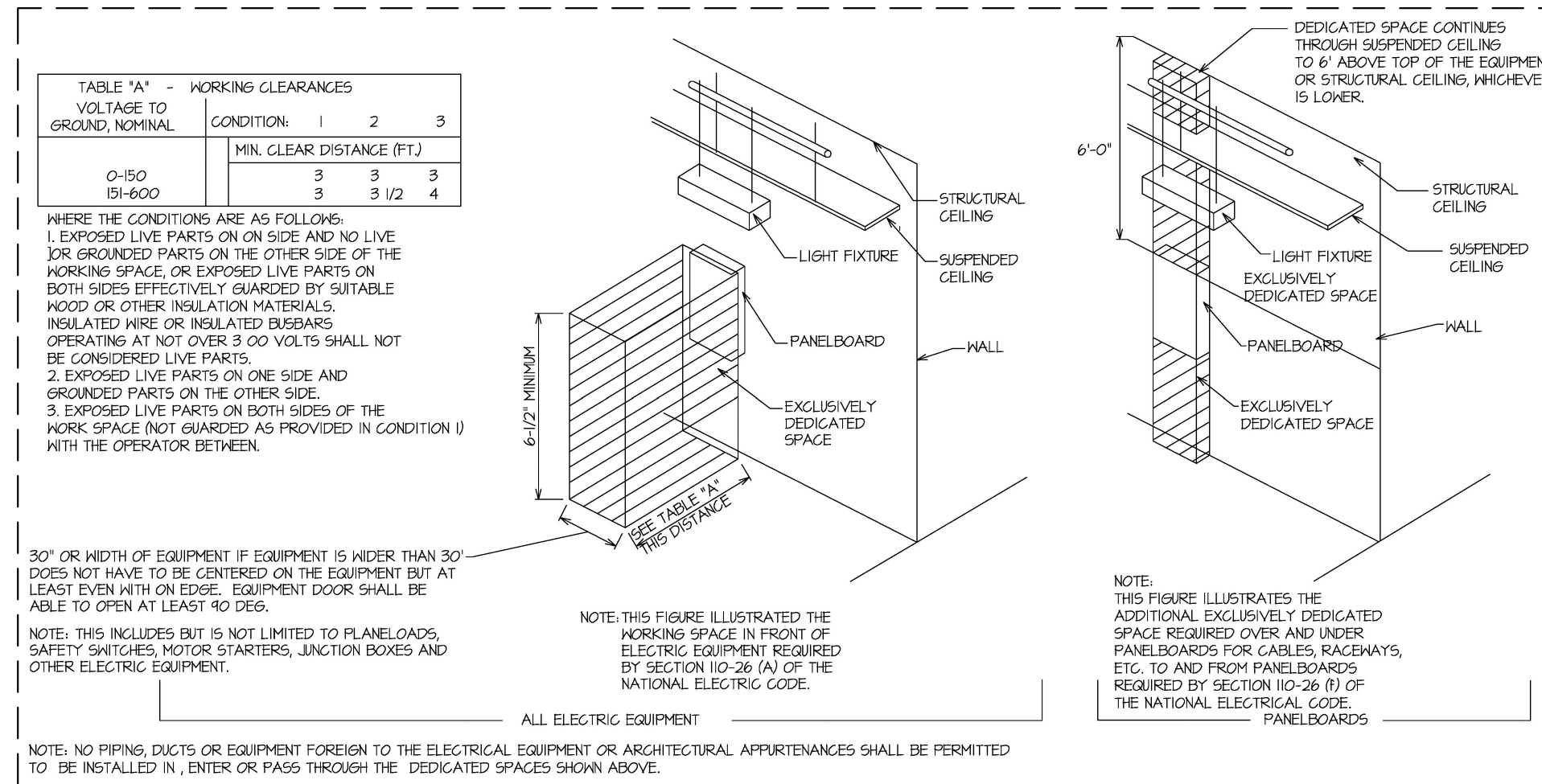

POWER EQUIPMENT SERVICE AREAS

## ELECTRICAL SYSTEM AND INSTALLATION NOTES

- ALL WORK SHALL CONFORM TO STATE, LOCAL, AND FEDERAL CODES, INCLUDING THE LATEST EDITIONS OF THE NATIONAL ELECTRICAL CODE AND THE INTERNATIONAL BUILDING CODE.
- MINIMUM WIRE SIZE SHALL BE 12AWG CU UNLESS OTHERWISE NOTED.
- HOMERUNS GREATER THAN 100 FEET SHALL BE 10AWG CU MINIMUM.
- ALL CIRCUITRY SHALL BE RUN IN EMT, IMC, OR RIGID CONDUIT.
- E.C. TO FURNISH AND INSTALL ALL NECESSARY MATERIALS AND LABOR TO ENSURE A COMPLETE AND OPERABLE SYSTEM.
- E.C. RESPONSIBLE FOR OBTAINING AND MAINTAINING ALL REQUIRED PERMITS, INSPECTIONS, LICENSES ETC., NECESSARY TO COMPLETE THIS PROJECT.
- PROVIDE RETURN DUCT MOUNTED SMOKE DETECTORS IN ALL CENTRAL AIR HANDLING UNITS, TO BE INTERLOCKED WITH FIRE ALARM PANEL (BY OTHERS).
- INSTALL NECESSARY CIRCUITS, WIRING, AND JUNCTION BOXES AS REQUIRED FOR COMPLETE SIGNAGE AND ACCENT ILLUMINATION. COORDINATE WITH INSTALLER.
- ALL LOW VOLTAGE WIRING TO BE RUN IN COLOR CODED SMURFF TUBES. BLUE FOR TV, RED FOR FIRE ALARM, AND YELLOW FOR TV/DATA.
- ALL CAN LIGHTS, RECEPTACLES, AND JUNCTION BOXES IN RATED ASSEMBLIES TO BE RATED WITH EITHER BOXES BUILT-UP TYPE-X CWB, 3M MPP+ UL RATED PUTTY, OR RATED FIXTURE(S).

ELECTRICAL FEEDS - 3ph						
BREAKER OR LOAD	FEEDS	GROUND	E.M.T.	FEEDS	GROUND	E.M.T.
THHN CU (194°F)						
SINGLE SET						
20 A	12 Awg	12 Awg	1/2"			
30 A	10 Awg	10 Awg	1/2"			
40 A	8 Awg	10 Awg	3/4"			
50 A	6 Awg	10 Awg	3/4"			
60 A	6 Awg	10 Awg	1"			
150 A	1/0	6 Awg	2"			
200 A	3/0	6 Awg	2"	3 Awg	8 Awg	1 1/4"
225 A	4/0	4 Awg	2"	2 Awg	6 Awg	1 1/4"
400 A	#500	3 Awg	3 1/2"	3/0	6 Awg	2"
600 A				#300	4 Awg	2 1/2"
800 A				#500	3 Awg	2 1/2"

NOTES  
 FEEDERS PER '20 NEC Table 8.310.15(B)(2)(1)  
 NEUTRAL ... '20 NEC same as feeders  
 GROUND PER '20 NEC Table 250.66  
 EMT CONDUIT PER '20 NEC Table C.1

BONDING OF METAL VENEERS	
ELECTRICAL CONTRACTOR SHALL PROVIDE ADEQUATE BONDING OF THE INSTALLED METAL VENEER PANELS, PURSUANT TO SECTION 250 OF THE 2020 NFPA-70 (NEC) WITH NORTH CAROLINA AMENDMENTS AND TO THE SATISFACTION OF THE LOCAL ELECTRICAL CODE OFFICIAL/INSPECTOR HAVING AUTHORITY.	

## LIGHTING SCHEDULE

USE	TYPE	MANUF.	MODEL	LAMPS	V <sub>in</sub>	V	DESCRIPTION
EXT. DOWNLIGHT	CAN	LITHONIA	LDNA 35/30 L06AR	LED 35	120		NEW CONSTRUCTION 6" DOWNLIGHT CAN
WAREHOUSE	HIGH-BAY	LITHONIA	CPHB 15000LM SEF GCL	LED 96	120		HIGH BAY LED W/ MVOLT GANGED TECHNOLOGY
EXT. CANOPY	HIGH-BAY	LITHONIA	SCN7 LED AL02 SSW2 PFL	LED 5	130	120	HIGH BAY LED W/ MVOLT GANGED TECHNOLOGY
2X2 TRICIFIER	CEILING	LITHONIA	212L ADL RW LP35S	LED 40	120		2X2 LED TRICIFIER 0.152" #12 ACRYLIC LENS, WHITE FINISH
EXTERIOR AREA	WALL	P.B.O.	P.B.O.	LED 5	90	120	ENCLOSED, ON LIGHT SENSOR
EXIT + E.M.	STANDARD	LITHONIA	LHQML ED R HO	LED 10	120	120	EXIT + EMERG COMBO, WALL/CLG MTD, 90 MIN. BATT. BACK-UP, WHITE
EM EMERG.	HIGH-BAY	LITHONIA	ELMEL	LED 8	120		HIGH BAY EMERG. WALL/CLG MTD, 90 MIN. BATTERY BACK-UP
EX EMERG. EXT.	HIGH-BAY	LITHONIA	ELMEL + WPVS	LED 8	120		EXTERIOR HIGH BAY EMERG. WALL/CLG MTD, 90 MIN. BATTERY BACK-UP
REMOTE EMERG.	STANDARD	LITHONIA	ELA B T QWP L0309	LED 28	120		EXTERIOR/W/ET RATED 2 LAMPS, BLACK FINISH, 90 MIN. BATTERY BACK-UP

NOTE: LIGHT FIXTURE SUBSTITUTIONS ALLOWED WITH MATCHING PARAMETERS BY OWNER REQUEST, CODE COMPLIANCE AND AHJ APPROVAL.  
 OFFICES, BREAK ROOMS, RESTROOMS AND OTHER BUSINESS AREAS TO BE MOTION ACTIVATED TO 50% MANUAL ON TO 100% 30min MOTION SHUTOFF, AND MANUAL OFF.  
 TIME SWITCH CONTROLS ARE PERMISSIBLE PER OWNER PROVIDED THAT PROGRAMMING IS 4-50% CAPABLE AND NIGHT LIGHTING IS INCORPORATED.  
 E.C. TO COORDINATE ALL EXIT SIGNAGE AND EGRESS LIGHTING LOCATIONS, SELECTIONS AND SPACING, PRIOR TO PLACING ORDER, WITH OWNER AND AHJ.

#	Load Designation / Use	VA per phase				L1 L3	Feeder Size	Conduit Size	Breaker Size	VA per phase				Load Designation / Use
		Line	Line	Line	Line					Line	Line	Line	Line	
1	RECEPTACLES - SOUTH	5172	5172	5172	15 A	12 Awg	12 Awg	15 A	120	120	120	15 A	RECEPTACLES - SOUTH	
2	RECEPTACLES - WEST	1000	1000	1000	15 A	12 Awg	12 Awg	15 A	120	120	120	15 A	RECEPTACLES - WEST	
3	RECEPTACLES - SOUTHWEST	1000	1000	1000	15 A	12 Awg	12 Awg	15 A	120	120	120	15 A	RECEPTACLES - SOUTHWEST	
4	RECEPTACLES - SOUTHWEST	1000	1000	1000	15 A	12 Awg	12 Awg	15 A	120	120	120	15 A	RECEPTACLES - SOUTHWEST	
5	RECEPTACLES - EAST	1000	1000	1000	15 A	12 Awg	12 Awg	15 A	120	120	120	15 A	RECEPTACLES - EAST	
6	RECEPTACLES - WEST	1000	1000	1000	15 A	12 Awg	12 Awg	15 A	120	120	120	15 A	RECEPTACLES - WEST	
7	RECEPTACLES - WEST	1000	1000	1000	15 A	12 Awg	12 Awg	15 A	120	120	120	15 A	RECEPTACLES - WEST	
8	RECEPTACLES - WEST	1000	1000	1000	15 A	12 Awg	12 Awg	15 A	120	120	120	15 A	RECEPTACLES - WEST	
9	RECEPTACLES - WEST	1000	1000	1000	15 A	12 Awg	12 Awg	15 A	120	120	120	15 A	RECEPTACLES - WEST	
10	RECEPTACLES - WEST	1000	1000	1000	15 A	12 Awg	12 Awg	15 A	120	120	120	15 A	RECEPTACLES - WEST	
11	RECEPTACLES - WEST	1000	1000	1000	15 A	12 Awg	12 Awg	15 A	120	120	120	15 A	RECEPTACLES - WEST	
12	RECEPTACLES - WEST	1000	1000	1000	15 A	12 Awg	12 Awg	15 A	120	120	120	15 A	RECEPTACLES - WEST	
13	RECEPTACLES - WEST	1000	1000	1000	15 A	12 Awg	12 Awg	15 A	120	120	120	15 A	RECEPTACLES - WEST	
14	RECEPTACLES - WEST	1000	1000	1000	15 A	12 Awg	12 Awg	15 A	120	120	120	15 A	RECEPTACLES - WEST	
15	RECEPTACLES - WEST	1000	1000	1000	15 A	12 Awg	12 Awg	15 A	120	120	120	15 A	RECEPTACLES - WEST	
16	RECEPTACLES - WEST	1000	1000	1000	15 A	12 Awg	12 Awg	15 A	120	120	120	15 A	RECEPTACLES - WEST	
17	RECEPTACLES - WEST	1000	1000	1000	15 A	12 Awg	12 Awg	15 A	120	120	120	15 A	RECEPTACLES - WEST	
18	RECEPTACLES - WEST	1000	1000	1000	15 A	12 Awg	12 Awg	15 A	120	120	120	15 A	RECEPTACLES - WEST	
19	RECEPTACLES - WEST	1000	1000	1000	15 A	12 Awg	12 Awg	15 A	120	120	120	15 A	RECEPTACLES - WEST	
20	RECEPTACLES - WEST	1000	1000	1000	15 A	12 Awg	12 Awg	15 A	120	120	120	15 A	RECEPTACLES - WEST	
21	RECEPTACLES - WEST	1000	1000	1000	15 A	12 Awg	12 Awg	15 A	120	120	120	15 A	RECEPTACLES - WEST	
22	RECEPTACLES - WEST	1000	1000	1000	15 A	12 Awg	12 Awg	15 A	120	120	120	15 A	RECEPTACLES - WEST	
23	RECEPTACLES - WEST	1000	1000	1000	15 A	12 Awg	12 Awg	15 A	120	120	120	15 A	RECEPTACLES - WEST	
24	RECEPTACLES - WEST	1000	1000	1000	15 A	12 Awg	12 Awg	15 A	120	120	120	15 A	RECEPTACLES - WEST	
25	RECEPTACLES - WEST	1000	1000	1000	15 A	12 Awg	12 Awg	15 A	120	120	120	15 A	RECEPTACLES - WEST	
26	RECEPTACLES - WEST	1000	1000	1000	15 A	12 Awg	12 Awg	15 A	120	120	120	15 A	RECEPTACLES - WEST	
27	RECEPTACLES - WEST	1000	1000	1000	15 A	12 Awg	12 Awg	15 A	120	120	120	15 A	RECEPTACLES - WEST	
28	RECEPTACLES - WEST	1000	1000	1000	15 A	12 Awg	12 Awg	15 A	120	120	120	15 A	RECEPTACLES - WEST	
29	RECEPTACLES - WEST	1000	1000	1000	15 A	12 Awg	12 Awg	15 A	120	120	120	15 A	RECEPTACLES - WEST	
30	RECEPTACLES - WEST	1000	1000	1000	15 A	12 Awg	12 Awg	15 A	120	120	120	15 A	RECEPTACLES - WEST	
31	RECEPTACLES - WEST	1000	1000	1000	15 A	12 Awg	12 Awg	15 A	120	120	120	15 A	RECEPTACLES - WEST	
32	RECEPTACLES - WEST	1000	1000	1000	15 A	12 Awg	12 Awg	15 A	120	120	120	15 A	RECEPTACLES - WEST	
33	RECEPTACLES - WEST	1000	1000	1000	15 A	12 Awg	12 Awg	15 A	120	120	120	15 A	RECEPTACLES - WEST	
34	RECEPTACLES - WEST	1000	1000	1000	15 A	12 Awg	12 Awg	15 A	120	120	120	15 A	RECEPTACLES - WEST	
35	RECEPTACLES - WEST	1000	1000	1000	15 A	12 Awg	12 Awg	15 A	120	120	120	15 A	RECEPTACLES - WEST	
36	RECEPTACLES - WEST	1000	1000	1000	15 A	12 Awg	12 Awg	15 A	120	120	120	15 A	RECEPTACLES - WEST	
37	RECEPTACLES - WEST	1000	1000	1000	15 A	12 Awg	12 Awg	15 A	120	120	120	15 A	RECEPTACLES - WEST	
38	RECEPTACLES - WEST	1000	1000	1000	15 A	12 Awg	12 Awg	15 A	120	120	120	15 A	RECEPTACLES - WEST	
39	RECEPTACLES - WEST	1000	1000	1000	15 A	12 Awg	12 Awg	15 A	120	120	120	15 A	RECEPTACLES - WEST	
40	RECEPTACLES - WEST	1000	1000	1000	15 A	12 Awg	12 Awg	15 A	120	120	120	15 A	RECEPTACLES - WEST	
41	RECEPTACLES - WEST	1000	1000	1000	15 A	12 Awg	12 Awg	15 A	120	120	120	15 A	RECEPTACLES - WEST	
42	RECEPTACLES - WEST	1000	1000	1000	15 A	12 Awg	12 Awg	15 A	120	120	120	15 A	RECEPTACLES - WEST	
43	RECEPTACLES - WEST	1000	1000	1000	15 A	12 Awg	12 Awg	15 A	120	120	120	15 A	RECEPTACLES - WEST	
44	RECEPTACLES - WEST	1000	1000	1000	15 A	12 Awg	12 Awg	15 A	120	120	120	15 A	RECEPTACLES - WEST	
45	RECEPTACLES - WEST	1000	1000	1000	15 A	12 Awg	12 Awg	15 A	120	120	120	15 A	RECEPTACLES - WEST	
46	RECEPTACLES - WEST	1000	1000	1000	15 A	12 Awg	12 Awg	15 A	120	120	120	15 A	RECEPTACLES - WEST	
47	RECEPTACLES - WEST	1000	1000	1000	15 A	12 Awg	12 Awg	15 A	120	120	120	15 A	RECEPTACLES - WEST	
48	RECEPTACLES - WEST	1000	1000	1000	15 A	12 Awg	12 Awg	15 A	120	120	120	15 A	RECEPTACLES - WEST	
49	RECEPTACLES - WEST	1000	1000	1000	15 A	12 Awg	12 Awg	15 A	120	120	120	15 A	RECEPTACLES - WEST	

