

GENERAL NOTES

1.0 THIS PROJECT HAS BEEN DESIGNED FOR THE WEIGHTS AND MATERIALS INDICATED ON THE DRAWINGS AND FOR THE LIVE LOADS INDICATED IN THE DESIGN DATA.
1.1 COORDINATE THESE DRAWINGS WITH THE ARCHITECTURAL, MECHANICAL, ELECTRICAL, PLUMBING, AND CIVIL DRAWINGS.
1.2 THE CONTRACTOR SHALL REFER TO THE ARCHITECTURAL, MECHANICAL, ELECTRICAL AND PLUMBING DRAWINGS FOR SLEEVES, CURBS, INSERTS OR OPENINGS, ETC. NOT HEREIN INDICATED.
1.3 (NOT USED)
1.4 SLAB OPENINGS SMALLER THAN 10" AND NOT INDICATED ON PLAN SHALL BE CORE DRILLED IN FIELD U.N.O. SEE MECHANICAL, ELECTRICAL AND PLUMBING DRAWINGS FOR LOCATIONS OF THESE OPENINGS.
1.5 WORK NOT INCLUDED ON THE DRAWINGS BUT IMPLIED TO BE SIMILAR TO THAT SHOWN AT CORRESPONDING PLACES ELSEWHERE ON THE DRAWINGS SHALL BE REPEATED.
1.6 IN CASE OF CONFLICT BETWEEN THE NOTES, DETAILS AND SPECIFICATIONS, THE MOST RIGID REQUIREMENTS SHALL GOVERN.
1.7 THE CONTRACTOR SHALL SUBMIT FOR REVIEW, DRAWINGS AND CALCULATIONS SIGNED AND SEALED BY A STRUCTURAL ENGINEER IN THE STATE OF NORTH CAROLINA FOR THE METAL STAIRS AND RAILINGS. REVIEW SHALL BE FOR GENERAL CONFORMANCE TO LOCAL BUILDING CODES, DESIGN PARAMETERS LISTED IN THE GENERAL NOTES AND GEOMETRY DESIGNATED IN THE DRAWINGS. THE CONTRACTOR SHALL BE RESPONSIBLE FOR FURNISHING AND INSTALLING EMBEDS AND HARDWARE AS REQUIRED BY THE STAIR DESIGN.
1.8 SEE ARCHITECTURAL DRAWINGS FOR LOCATIONS OF MASONRY AND DRYWALL NON-LOAD BEARING PARTITIONS. PROVIDE COMPRESSIBLE FIRESAFING AT TOP OF WALL AS REQUIRED.
2.0 FOUNDATION NOTES
2.1 GEOTECHNICAL INFORMATION FOR THIS PROJECT WAS TAKEN FROM GEOTECHNICAL EXPLORATION REPORT PREPARED BY S&ME, INC. DATED OCTOBER 17, 2022.
2.2 SEE THE SPECIFICATION REQUIREMENTS FOR EXCAVATION AND PREPARATION OF THE FOUNDATION AND SLAB ON GRADE SUBGRADE INCLUDING COMPACTION PROCEDURES.
2.3 EXCAVATIONS FOR FOOTINGS SHALL HAVE THE SIDES AND BOTTOM TEMPORARILY LINED WITH 6 MIL POLYETHYLENE IF PLACEMENT OF CONCRETE DOES NOT OCCUR WITHIN 24 HOURS OF THE EXCAVATION OF THE FOOTING.
2.4 FOUNDATION CONDITIONS NOTED DURING CONSTRUCTION WHICH DIFFER FROM THOSE DESCRIBED IN THE GEOTECHNICAL REPORT SHALL BE REPORTED TO THE GENERAL CONTRACTOR BEFORE FURTHER CONSTRUCTION IS ATTEMPTED. SEE PROJECT SPECIFICATIONS.
2.5 NO FOOTINGS OR SLABS SHALL BE POURED INTO OR AGAINST SUBGRADE CONTAINING FREE WATER, FROST, ICE OR LOOSE MATERIAL.
2.6 SEE PLUMBING, ELECTRICAL & CIVIL DRAWINGS FOR REQUIRED UNDERSLAB UTILITIES.
2.7 SEE SPECIFICATIONS FOR ALL WATERPROOFING DETAILS AND MATERIALS AS REQUIRED.
2.8 IF UNDERMINING OF FOOTING OCCURS, FILL VOIDS WITH 2500 PSI CONCRETE. DO NOT ATTEMPT TO REPLACE AND RECOMPACT SOIL.
3.0 CONCRETE
3.1 CONCRETE SHALL HAVE THE UNIT WEIGHT AND THE MINIMUM COMPRESSIVE STRENGTHS (fc) AT 28 DAYS AS SHOWN ON THE CONCRETE MATERIALS SCHEDULE. (DWG S-0002) SEE SPECIFICATIONS FOR FURTHER INFORMATION.
3.2 ENTRAIN AIR TO PRODUCE TOTAL AIR CONTENT ACCORDING TO THE SPECIFICATIONS. FOR CONCRETE EXPOSED TO FREEZING TEMPERATURES (EXTERIOR FOOTINGS, SLAB TURNDOWNS, EXTERIOR SLABS AND SLABS-ON-GRADE.)
3.3 GROUT FOR BASE PLATES SHALL BE NON-SHRINKABLE GROUT AND SHALL HAVE A MINIMUM SPECIFIED COMPRESSIVE STRENGTH AT 28 DAYS OF 5000 PSI, U.N.O.
3.4 NO CALCIUM CHLORIDE SHALL BE USED IN ANY CONCRETE.
3.5 MIXING, TRANSPORTING AND PLACING OF CONCRETE SHALL CONFORM TO ACI-301.
3.6 ALL CONCRETE WORK SHALL CONFORM TO THE REQUIREMENTS OF ACI-318, "BUILDING CODE REQUIREMENTS FOR STRUCTURAL CONCRETE", AND CONTRACT SPECIFICATIONS. WHEN THERE IS A CONFLICT BETWEEN ACI AND SPECIFICATIONS, THE MORE STRINGENT SHALL GOVERN.
3.7 CHAMFER ALL EXPOSED EXTERNAL CORNERS OF CONCRETE WITH 3/4" X 45 DEGREE CHAMFER U.N.O.
3.8 CONCRETE REINFORCEMENT BARS SHALL CONFORM TO ASTM A615, GRADE 60. REINFORCING BARS SHALL NOT BE TACK WELDED, WELDED, HEATED OR CUT, UNLESS INDICATED ON THE CONTRACT DOCUMENTS. ALL LAP SPLICES SHALL BE CLASS 'B' U.N.O.
3.9 HORIZONTAL FOOTING AND HORIZONTAL WALL REINFORCEMENT SHALL BE CONTINUOUS AND SHALL HAVE 90 DEGREE BENDS AND EXTENSIONS, OR CORNER BARS OF EQUIVALENT SIZE LAPPED WITH A CLASS B TENSION SPLICE AT CORNERS AND INTERSECTIONS. TOP BAR CRITERIA SHALL APPLY IF 12" OR MORE OF FRESH CONCRETE IS PLACED BELOW BAR.
3.10 SLABS-ON-GRADE SHALL HAVE CONSTRUCTION JOINTS OR CRACK CONTROL JOINTS AS SHOWN ON THE DRAWINGS. CONSTRUCTION JOINTS CAN BE USED AT CONTROL JOINT LOCATIONS AT CONTRACTORS OPTION. SEE SLAB PLANS & JOINT DETAILS FOR ADDITIONAL INFORMATION.
3.11 (NOT USED)
3.12 ALL WELDED WIRE FABRIC SHALL CONFORM TO THE STANDARDS OF ASTM A-185. SUPPLY IN FLAT SHEETS.
3.13 ALL CONCRETE REINFORCEMENT SHALL BE DETAILED, FABRICATED, LABELED, SUPPORTED, AND SPACED IN FORMS AND SECURED IN PLACE IN ACCORDANCE WITH THE PROCEDURES AND REQUIREMENTS OUTLINED IN THE LATEST EDITION OF THE "BUILDING CODE REQUIREMENTS FOR REINFORCED CONCRETE", ACI 318, AND THE "MANUAL OF STANDARD PRACTICE FOR DETAILING REINFORCED CONCRETE STRUCTURES", ACI 315, LATEST EDITION.
3.14 SHOP DRAWINGS SHOWING REINFORCING DETAILS, INCLUDING STEEL SIZES, SPACING AND PLACEMENT SHALL BE SUBMITTED FOR REVIEW PRIOR TO FABRICATION.
3.15 ALL WELDED WIRE FABRIC SHALL BE LAPPED TWO (2) FULL MESH PANELS AND TIED SECURELY.
3.16 ALL DOWELS SHALL MATCH SIZE AND NUMBER OF MAIN REINFORCING, U.N.O. ON DRAWINGS.
3.17 ADDITIONAL BARS SHALL BE PROVIDED AROUND ALL FLOOR AND WALL OPENINGS AS SHOWN ON THE DRAWINGS.
3.18 SEE ARCHITECTURAL DRAWINGS FOR TYPE AND LOCATION OF ALL FLOOR FINISHES.
3.19 (NOT USED)
3.20 U.N.O., ALL CURBS SHALL BE REINFORCED WITH AT LEAST 1 #4 CONTINUOUS AND #4 AT 12" O.C. DOWELS TO STRUCTURE BELOW.
3.21 THE SUB-CONTRACTOR SHALL VERIFY ALL OPENINGS, PAD SIZES, AND ANCHOR BOLTS WITH EQUIPMENT SELECTED.
3.22 (NOT USED)
3.23 (NOT USED)
3.24 (NOT USED)
3.25 (NOT USED)
3.26 PROVIDE ADDITIONAL 2-#4 X 3'-0" REINFORCING BARS IN SLAB-ON-GRADE AT ALL RE-ENTRANT CORNERS. PLACE BARS AT MID-DEPTH OF SLAB WITH A CLEARANCE OF 2" FROM CORNER U.N.O.

4.0 PRE-ENGINEERED METAL BUILDING
4.1 CONTRACTOR SHALL MAINTAIN A SET OF THE LATEST PRE-ENGINEERED METAL BUILDING DRAWINGS ON SITE. THESE SHALL BE MADE AVAILABLE FOR FOR REVIEW BY THE ENGINEER OR BUILDING INSPECTOR UPON REQUEST.
4.2 FOUNDATION DESIGN SHALL BE VERIFIED WITH COLUMN REACTION REPORT TO BE PROVIDED BY THE PRE-ENGINEERED METAL BUILDING SUPPLIER.
4.3 THE DESIGN SHALL BE THE RESPONSIBILITY OF THE PRE-ENGINEERED BUILDING MANUFACTURER AND SHALL BE PREPARED UNDER THE DIRECT SUPERVISION OF A PROFESSIONAL ENGINEER REGISTERED IN THE STATE OF NORTH CAROLINA.
4.4 DESIGN CRITERIA
A. PRIMARY AND SECONDARY STRUCTURAL MEMBERS AND EXTERIOR COVERING MATERIALS: METAL BUILDING MANUFACTURER'S ASSOCIATION'S (MBMA) "DESIGN PRACTICES MANUAL".
B. STRUCTURAL STEEL MEMBERS: AMERICAN INSTITUTE OF STEEL CONSTRUCTION'S (AISC) "SPECIFICATIONS FOR THE DESIGN, FABRICATION AND ERECTION OF STRUCTURAL STEEL FOR BUILDINGS"
C. LIGHT GAGE STEEL MEMBERS: AMERICAN IRON AND STEEL INSTITUTES (AISI) "SPECIFICATION FOR THE DESIGN OF COLD FORMED STEEL STRUCTURAL MEMBERS" AND "DESIGN OF LIGHT GAGE STEEL DIAPHRAGMS".
D. FOR WELDED CONNECTIONS: AMERICAN WELDING SOCIETY'S (AWS)" STANDARD CODE FOR ARC AND GAS WELDING IN BUILDING CONSTRUCTION".
E. DRIFT CRITERIA:
i. MAIN BUILDING: H/100
ii. MAIN BUILDING W/ CRANE: PER CRANE MANUFACTURER'S RECOMMENDATIONS
4.5 DESIGN LOADS: BASIC DESIGN LOADS, AS WELL AS AUXILIARY AND COLLATERAL LOADS, ARE INDICATED BELOW.
A. GRAVITY LIVE LOADS, WIND AND SEISMIC LOADS AS INDICATED IN "DESIGN CRITERIA" SECTION OF THESE NOTES.
B. BASIC DESIGN LOADS INCLUDE, IN ADDITION TO DEAD LOAD, LIVE LOAD, WIND LOAD & SEISMIC LOAD.
C. COLLATERAL LOADS INCLUDE ADDITIONAL DEAD LOADS OVER AND ABOVE THE WEIGHT OF THE METAL BUILDING SYSTEM SUCH AS MECHANICAL SYSTEMS AND LIGHTING LOADS.
D. DESIGN EACH MEMBER TO WITHSTAND STRESSES RESULTING FROM COMBINATIONS OF LOADS THAT PRODUCE ALLOWABLE STRESSES IN THAT MEMBER, AS PRESCRIBED IN MBMA'S "DESIGN PRACTICES MANUAL".
4.6 SUBMIT COMPLETE DESIGN CALCULATIONS AND ERECTION DRAWINGS SHOWING ANCHOR BOLT SETTINGS, SIDEWALL, ENDWALL, AND ROOF FRAMING, TRANSVERSE CROSS SECTIONS, COVERING AND TRIM DETAILS, AND ACCESSORY INSTALLATION DETAILS TO CLEARLY INDICATE PROPER ASSEMBLY OF BUILDING COMPONENTS.
4.7 DESIGN CALCULATIONS AND ERECTION DRAWINGS SHALL BE SEALED AND SIGNED BY A PROFESSIONAL ENGINEER REGISTERED IN THE STATE OF NORTH CAROLINA.
4.8 FRAMES SHALL BE DESIGNED ON THE BASIS OF ELASTIC BEHAVIOR.
4.9 STRUCTURAL PLATE OR BAR STOCK SHALL HAVE A MINIMUM YIELD OF 50 ksi
4.10 COLD-FORMED STRUCTURAL STEEL SHALL HAVE A MINIMUM YIELD STRENGTH OF 55 ksi.
4.11 PRE-ENGINEERED METAL BUILDING MFG. SHALL PROVIDE COLUMN REACTION REPORT TO STRUCTURAL ENGINEER OF RECORD FOR VERIFICATION OF FOUNDATION DESIGN.
4.12 IF THE METAL STRUCTURE FURNISHED HAS REACTIONS WHICH EXCEED THOSE GIVEN ABOVE, THE CONTRACTOR SHALL BE RESPONSIBLE FOR THE REDESIGN OF THE FOUNDATIONS RESUBMITTED FOR APPROVAL.
4.13 ANCHOR BOLTS FOR ALL COLUMNS SHALL BE DESIGNED, SIZED (INCLUDING EMBED LENGTHS) AND FURNISHED BY THE BUILDING MANUFACTURER.
5.0 NOT USED
6.0 STRUCTURAL STEEL
6.1 STRUCTURAL STEEL ROLLED SHAPES AND PLATES SHALL CONFORM TO THE MATERIAL INFORMATION SCHEDULE ON SHEET S-0002. DIMENSIONS AND PROPERTIES SHALL BE IN ACCORDANCE TO ASTM A6
6.2 ANCHOR BOLTS SHALL CONFORM TO ASTM A36, A307, OR F1554 UNLESS NOTED OTHERWISE.
6.3 CONNECTION BOLTS FOR STRUCTURAL STEEL MEMBERS SHALL BE 3/4" DIA. A325-N, UNO, AND SHALL CONFORM TO ASTM A325; NUTS SHALL CONFORM TO ASTM A563. WASHERS SHALL CONFORM TO ASTM F436. CONNECTION BOLTS SHALL HAVE A HARDENED WASHER PLACED UNDER THE ELEMENT TO BE TIGHTENED.
6.4 DETAILING OF STRUCTURAL STEEL CONNECTIONS MUST BE CONSISTENT WITH RECOGNIZED, PUBLISHED METHODS SUCH AS IN THE AISC "MANUAL OF STEEL CONSTRUCTION", LATEST EDITION; "ENGINEERING FOR STEEL CONSTRUCTION", OR "VOLUME II CONNECTIONS MANUAL OF STEEL CONSTRUCTION".
6.4.1 SECTION A7 OF AISC CURRENT EDITION IS AMENDED SUCH THAT THE FABRICATOR IS RESPONSIBLE FOR THE DESIGN AND DETAILING OF ALL CONNECTIONS.
6.5 (NOT USED)
6.5.1 (NOT USED)
6.6 (NOT USED)
6.7 (NOT USED)

6.8 CALCULATIONS FOR DETAILS MUST SHOW A RATIONAL ANALYSIS OF A COMPLETE LOAD PATH, INCLUDING LOCAL EFFECTS ON WEBS, FLANGES, ETC. OF THE CONNECTED MEMBERS AND THE DEVICES (PLATES, SEATS, BRACKETS, BOLTS, WEBS, ETC) AFFECTING ALL CONNECTIONS. FAILURE TO SUBMIT SUCH CALCULATIONS FOR REVIEW CONCURRENT WITH SHOP DRAWING ERECTION PLANS AND DETAILS WILL BE CAUSE FOR REJECTION OF THAT SUBMITTAL.
6.8.1 ALL SHEAR TAB CONNECTIONS SUBMITTED AS AN ALTERNATE FOR APPROVAL SHALL BE DESIGNED USING A FLEXIBLE SUPPORT CONDITION.
6.8.2 BEAM AND GIRDER CONNECTIONS SHALL BE DESIGNED SUCH THAT ALL ADDITIONAL STRESSES DUE TO CONNECTION ECCENTRICITY SHALL BE DEVELOPED BY THE CONNECTION AND NOT INDUCE ANY ADDITIONAL STRESSES INTO SUPPORTING MEMBERS.
6.9 STRUCTURAL STEEL DETAILING, FABRICATION AND ERECTION SHALL CONFORM TO THE AISC "SPECIFICATION FOR STRUCTURAL STEEL BUILDINGS - ALLOWABLE STRESS DESIGN AND PLASTIC DESIGN" (LATEST EDITION), AND THE AISC "CODE OF STANDARD PRACTICE FOR STEEL BUILDINGS AND BRIDGES" (LATEST EDITION)
6.10 WELDING SHALL CONFORM TO THE AMERICAN WELDING SOCIETY STRUCTURAL WELDING CODE AWS D1.1. ELECTRODES FOR SHOP AND FIELD WELDS SHALL BE CLASS E70XX. ALL WELDING SHALL BE DONE BY QUALIFIED, CERTIFIED WELDERS PER THE ABOVE STANDARD.
6.11 SHOP AND FIELD TESTING OF WELDS AND BOLTS SHALL BE AS OUTLINED IN THE SPECIFICATIONS.
6.12 ALL WELDS NOT INDICATED SHALL BE A MINIMUM OF 1/4" ALL AROUND UNLESS NOTED OTHERWISE.
6.13 THERE SHALL BE NO FIELD CUTTING OF STRUCTURAL STEEL MEMBERS FOR THE WORK OF OTHER TRADES WITHOUT PRIOR APPROVAL OF THE STRUCTURAL ENGINEER.
7.0 ANCHORING TO CONCRETE
7.1 EXCEPT WHERE INDICATED ON THE DRAWINGS, POST-INSTALLED ANCHORS SHALL CONSIST OF ONE OF THE FOLLOWING ANCHOR TYPES. ANCHORS SHALL BE BY HILTI, SIMPSON STRONG-TIE, POWERS FASTENERS, OR A MANUFACTURER WITH EQUAL PRODUCTS AS REFERENCED IN THE CONSTRUCTION DOCUMENTS. PROVIDED ANCHORS SHALL HAVE PROPER TESTING AND ACCREDITATION BY ICC FOR THEIR INTENDED USE.
a. ANCHORAGE TO CONCRETE
i. ADHESIVE ANCHORS FOR USE WITH CRACKED AND UNCRACKED CONCRETE.
ii. MEDIUM DUTY MECHANICAL ANCHORS FOR USE WITH CRACKED AND UNCRACKED CONCRETE.
iii. HEAVY DUTY MECHANICAL ANCHORS FOR USE WITH CRACKED AND UNCRACKED CONCRETE.
b. REBAR DOWELING INTO CONCRETE
i. ADHESIVE ANCHORS FOR USE WITH CRACKED AND UNCRACKED CONCRETE.
7.2 SEE DRAWINGS FOR THE TYPE, SIZE, LOCATION AND MINIMUM EMBEDMENT DEPTH OF ANCHORS.
7.3 MINIMUM EDGE DISTANCE AS SHOWN OR IMPLIED IN THE CONSTRUCTION DRAWINGS SHALL BE MET.
7.4 INSPECTIONS OF POST-INSTALLED ANCHORS SHALL BE IN ACCORDANCE WITH THE SPECIAL INSPECTIONS REQUIREMENTS OF IBC AS SHOWN IN THESE CONSTRUCTION DOCUMENTS.
7.5 ANCHOR CAPACITY FOR THE SELECTED ANCHORS SHALL BE COMPATIBLE WITH THE ANCHORAGE CAPACITY LISTED FOR THE REFERENCED PRODUCT IN THE CONSTRUCTION DOCUMENTS. SUBSTITUTION REQUESTS FOR ALTERNATE PRODUCTS MUST BE APPROVED THRU THE SUBMITTAL PROCESS BY THE STRUCTURAL ENGINEER OF RECORD PRIOR TO USE. CONTRACTOR SHALL PROVIDE CALCULATIONS OR DOCUMENTATION DEMONSTRATING THAT THE SUBSTITUTED PRODUCT IS CAPABLE OF ACHIEVING THE PERFORMANCE VALUES OF THE REFERENCED PRODUCT. SUBSTITUTIONS SHALL BE EVALUATED BY THEIR HAVING AN ICC ESR SHOWING COMPLIANCE WITH THE RELEVANT BUILDING CODE FOR SEISMIC USE, LOAD RESISTANCE, INSTALLATION CATEGORY AND APPROPRIATE INSTALLATION INSTRUCTIONS.
7.6 ADHESIVE ANCHORS SELECTED ARE ASSUMED TO BE INSTALLED AFTER THE CONCRETE HAS BEEN CURED AND REACHED ITS 28-DAY SPECIFIED COMPRESSIVE STRENGTH. THE CONTRACTORS SHALL BE RESPONSIBLE FOR SELECTING AN APPROPRIATE ANCHOR FOR A SUBSTITUTION REQUEST (SEE NOTE 7.5 ABOVE) IF THE CONCRETE HAS NOT YET REACHED ITS 28-DAY SPECIFIED COMPRESSIVE STRENGTH AT THE TIME OF INSTALLATION.
7.7 INSTALL ANCHORS IN ACCORDANCE WITH THE MANUFACTURER'S INSTRUCTIONS. POST-INSTALLED ADHESIVE ANCHORS SHALL BE INSTALLED IN ACCORDANCE WITH THE MANUFACTURER INSTALLATION INSTRUCTIONS (MPII). INSTALLATION OF ADHESIVE ANCHORS SHALL BE PERFORMED BY PERSONNEL TRAINED TO INSTALL ADHESIVE ANCHORS.
7.8 ADHESIVE ANCHORS INSTALLED IN A HORIZONTAL OR UPWARDLY INCLINED ORINATION SHALL BE CONTINUOUSLY INSPECTED DURING INSTALLATION BY THE SPECIAL INSPECTOR. INSTALLATION OF THESE ANCHORS SHALL BE PERFORMED BY PERSONNEL CERTIFIED BY AN APPLICABLE CERTIFICATION PROGRAM. THE CERTIFICATION SHALL INCLUDE WRITTEN AND PERFORMANCE TESTS IN ACCORDANCE WITH THE ACI/CRSI ADHESIVE ANCHOR INSTALLER CERTIFICATION PROGRAM, OR EQUIVALENT.
7.9 ADHESIVE ANCHORS SHALL BE PROOF TESTED IN ACCORDANCE WITH ACI 355.4.
7.10 EXTERIOR ANCHORS SHALL BE GALVANIZED FOR PROTECTION FROM THE ELEMENTS.
7.11 THE CONTRACTOR SHALL ARRANGE AN ANCHOR MANUFACTURER'S REPRESENTATIVE TO PROVIDE. ONSITE INSTALLATION TRAINING FOR ALL OF THE PRODUCTS SPECIFIED. (THIS DOES NOT SUPERCEDE THE REQUIREMENTS OF NOTE 7.8 ABOVE.)

8.0 NOT USED
9.0 COLD-FORM METAL FRAMING (CFMF) NOTES:
9.1 ALL MEMBER DESIGN, SIZES AND NOMENCLATURE, ETC. ARE BASED ON STEEL STUD MANUFACTURERS ASSOCIATION'S (SSMA) PRODUCT TECHNICAL INFORMATION UTILIZING AISI 1996 COLD FORMED STEEL DESIGN MANUAL. ANY VARIATION FROM SSMA INFORMATION REQUIRES AN APPROVAL WITH COMPLETE TECHNICAL DATA, INCLUDING PROFILES, DESIGN CALCULATIONS, ETC. STAMPED BY A PROFESSIONAL ENGINEER REGISTERED IN THE STATE WHERE THE BUILDING IS TO BE CONSTRUCTED.
9.2 ALL STUDS, TRACKS AND JOISTS OF 18, 16, 14 OR 12 GAUGE TO BE CORROSION RESISTANT A653 CLASS 1, WITH A YIELD STRENGTH OF 50,000 PSI.
9.3 ALL STUDS, TRACKS AND JOISTS OF 20 OR 22 GAUGE TO BE CORROSION RESISTANT A653 GRADE 33, WITH A YIELD STRENGTH OF 33,000 PSI.
9.4 ALL BRIDGING AND CONNECTION PIECES TO BE CORROSION RESISTANT A653 GRADE 33, WITH A YIELD STRENGTH OF 33,000 PSI.
9.5 STUD AND JOISTS CONNECTIONS TO STUDS AND JOISTS THAT ARE TO BE WELDED SHALL BE BY AWS LIGHT GAUGE CERTIFIED WELDERS. MIN. WELD LENGTH = 1". ALL WELDS SHALL BE WIRE BRUSHED AND COATED WITH A ZINC RICH PRIMER OR GALVANIZING REPAIR PRODUCT.
9.6 USE THREE (3) STUDS (MINIMUM UNO) @ CORNERS OF ALL EXTERIOR WALLS. AND USE 2 FULL HEIGHT STUDS EA. SIDE OF OPENINGS.
9.7 WHEN SCREWS ARE USED FOR CONNECTIONS, THE MINIMUM SPACING IS 3/4" AND 1/2" FOR CLEARANCE TO MEMBER EDGE.
9.8 TRACK, BRIDGING AND CONNECTION PIECES TO BE WELDED OR SCREWED USING SELF TAPPING S-12 SCREWS, MIN. NO. 8. WHEN SCREWS ARE COVERED WITH DRYWALL, FINAL SCREWS SHALL HAVE PANCAKE HEADS OR SIMILAR. CONFIRM SCREWS WITH ARCHITECT.
9.9 ATTACHMENT OF TRACK OR CONNECTION PIECES TO CONCRETE SHALL BE AS SHOWN ON DESIGN DRAWINGS.
9.10 LATERAL BRIDGING SHALL BE PROVIDED WHERE SHOWN, AS A MINIMUM. CONNECT BRIDGING TO METAL STUDS.
9.11 NO SPLICES ARE ALLOWED IN STUDS OR JOISTS. SPLICES IN TRACK OR CONTINUOUS CONNECTION PIECES SHALL SUPPLY THE FULL STRENGTH OF THE MEMBER SPLICED.
9.12 ALL MEMBERS ARE TO BE INSTALLED PLUMB, LEVEL OR IN LINE WITH THE SLOPE OF THE STRUCTURE.
9.13 DURING CONSTRUCTION, TEMPORARY ERECTION BRACING, SHORING AND/OR SUPPORTS SHALL BE PROVIDED AS REQUIRED TO INSURE STRUCTURAL STABILITY UNTIL ALL STRUCTURAL COMPONENTS ARE PROPERLY INSTALLED, ALIGNED AND SECURED.
9.14 COLD-FORM METAL FRAMING (CFMF) MEMBER SIZES SHOWN ON DWGS. ARE MINIMUM SIZES. GENERAL CONTRACTOR SHALL OBTAIN ENGINEER TO DESIGN ALL LIGHT GAGE STEEL FRAMING SHOWN ON STRUCTURAL AND ARCHITECTURAL DRAWINGS. SHOP DRAWINGS AND CALCULATIONS SEALED BY ENGINEER REGISTERED IN NORTH CAROLINA SHALL BE SUBMITTED FOR APPROVAL FOR ALL FRAMING.
10.0 DELEGATED DESIGN ITEMS:
10.1 THE FOLLOWING ENGINEERED SYSTEMS AND COMPONENTS ARE DELEGATED FOR DESIGN TO A QUALIFIED SPECIALTY STRUCTURAL ENGINEER LICENSED IN THE STATE OF NORTH CAROLINA AND CONTRACTED BY THE CONTRACTOR. THESE SYSTEMS AND COMPONENTS INCLUDE, BUT ARE NOT LIMITED TO:
A. PREMANUFACTURED CANOPIES
B. PRE-ENGINEERED METAL BUILDING SYSTEMS AND STEEL HEADERS AT ROLL-UP DOORS
C. COLD-FORM METAL FRAMING (CFMF) AS BACKUP (SUPPORTING) EXTERIOR WALLS, SOFFITS, INTERIOR WALLS, SEAT WALLS AND FASCIA OR THOSE ACTING AS LOAD BEARING ELEMENTS.
D. ALL PEMB ANCHOR BOLT SIZES, QUANTITY AND EMBEDMENT LENGTHS.
E. SEISMIC BRACING FOR NON-STRUCTURAL COMPONENTS PER ASCE 7 CHAPTER 13
10.2 DELEGATED ENGINEERED SYSTEMS AND COMPONENTS SHALL SATISFY THE REQUIREMENTS OF THE APPLICABLE BUILDING CODES AND MATERIAL STANDARDS, INCLUDING AT A MINIMUM IBC 2018 AND ASCE 7-16.
10.3 SEE SPECIFICATIONS, BASIS OF DESIGN NOTES AND MATERIAL SPECIFIC NOTES FOR MATERIAL REQUIREMENTS, DESIGN CRITERIA, DETAILS OF THE SYSTEM/COMPONENT INTERFACE WITH THE PRIMARY STRUCTURE, AND SUBMITTAL AND CALCULATION REQUIREMENTS.

DRAWING NO. CFD-####-S-0001-44CC2B
DUKE ENERGY
MAILING ADDRESS: P.O. BOX 1007 CHARLOTTE, NC 28201
Safety Expectations: Reduce Risk, Remove Exposures to Hazards, Reinforce Safe Behavior
ILLNESS ZERO INJURY
LS3P
MMSA, Inc. Michael M. Simpson & Associates, Inc. Consulting Structural Engineers 30 Patewood Drive, Suite 100 Greenville, S.C. 29615 (864) 331-1201
SEAL
DUNN OPERATIONS CENTER
OPERATIONS BUILDING
PROJECT NO: DRAWING NUMBER CFD-####-S-0001-4122CB
ELECTRONIC FILE NAME: S0001.DWG
DRAWN BY: TML
CHK'D BY: MMS DATE: 09/22/2023
E-MAIL: msimpson@mmsainc.com
THIS DESIGN DRAWING IS THE EXCLUSIVE PROPERTY OF DUKE ENERGY CORPORATION AND IS CONSIDERED CONFIDENTIAL. IT SHALL NOT BE REPRODUCED, COPIED, OR DISTRIBUTED WITHOUT PRIOR APPROVAL. THIS INFORMATION SHOULD ONLY BE USED FOR THE SPECIFIC PROJECT INTENDED.
SHEET TITLE: GENERAL NOTES
SHEET NO. S-0001

**STRUCTURAL DESIGN CRITERIA**

ALL DESIGNS SHALL CONFORM TO THE PROVISIONS OF THE NORTH CAROLINA BUILDING CODE, 2018 EDITION, IBC 2015, ASCE 7-10)

**1.0 DESIGN LOADS**

**1.1 DEAD LOADS**

**1.1.1 ROOF DEAD LOADS**

ACTUAL WEIGHT OF PEMB ROOF SYSTEM & FRAMING

**1.1.2 PEMB ROOF COLLATERAL LOAD** 5 PSF (MINIMUM)

**1.2 LIVE LOADS (PER NCBC 2018 EDITION)**

**1.2.1 ROOF LIVE LOADS** 20 PSF (REDUCIBLE)

**1.2.2 GROUND FLOOR LIVE LOADS**

ALL AREAS, UNO 800 PSF (MOBILE STORAGE FLOOR)  
OFFICE AREA 100 PSF

**1.2.3 \*CRANE LOADS 10 TON, (SINGLE GIRDER, TOP RUNNING)**

TROLLEY WEIGHT: 3900 LBS  
CRANE WEIGHT: 15730 LBS  
RAIL: 40 LBS / YD  
WHEEL LOADS: 13,710 LBS  
VERTICAL IMPACT FORCE: 8500 LBS (ASCE 7, SECT. 4.9.3)  
LATERAL FORCE: 3000 LBS (ASCE 7, SECT. 4.9.4)  
LONGITUDINAL FORCE: 1500 LBS (ASCE 7, SECT. 4.9.5)

\* CRANE DESIGN LOADS ARE THE MAXIMUM ALLOWABLE CRANE LOADS. LOADS CAN BE SUBSTITUTED WITH LOADS SELECTED BY THE CONTRACTOR

**1.3 SNOW LOAD (PER NCBC 2018 EDITION)**

**1.3.1 DESIGN PARAMETERS**

GROUND SNOW LOAD,  $P_g = 10$  PSF

**1.4 WIND LOAD (PER NCBC 2018 EDITION, ASCE 7-10)**

**1.4.1 BASIC WIND SPEED**  $V = 119$  MPH  $U_{LT}$

EXPOSURE C; RISK CATEGORY II

ENCLOSURE CLASS: ENCLOSED (MAIN BUILDING)

**1.4.2 DESIGN WIND PRESSURE - MAIN WIND FORCE RESISTING SYSTEM (ULTIMATE)**

LOCATION	WALL WINDWARD + LEEWARD (@ MEAN ROOF HEIGHT)		ROOF		X (FT)
	INTERIOR ZONE	END ZONE	INTERIOR ZONE	END ZONE	
ALL AREAS, UNO	21 PSF	31 PSF	-26 PSF	-37 PSF	22

**1.4.3 DESIGN WIND PRESSURE (ULTIMATE) - WALL COMPONENTS & CLADDING**

EXTERIOR WALL SYSTEMS & THEIR ATTACHMENTS TO THE PRIMARY STRUCTURE SHALL BE DESIGNED FOR THE PRESSURES SHOWN IN THE DIAGRAM BELOW:

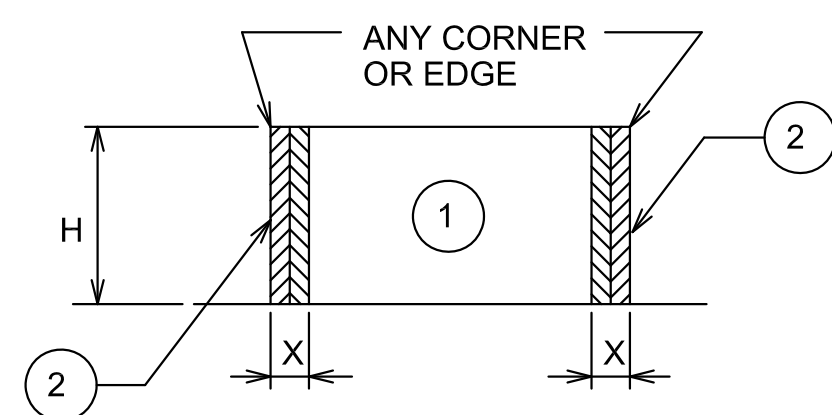

PRESSURE ON EXTERIOR WALL SYSTEMS FOR BUILDINGS WITH MEAN ROOF HEIGHT (H) = AS SHOWN

LOCATION	H	WINDWARD PRESSURE psf (INWARD)		LEEWARD PRESSURE psf (OUTWARD)		X (FT)
		①	②	①	②	
AREA $\leq 10$ ft <sup>2</sup>	0-31'	32	32	-35	-43	11
AREA = 50 ft <sup>2</sup>	0-31'	29	29	-32	-36	11
AREA $\geq 100$ ft <sup>2</sup>	0-31'	28	28	-30	-33	11

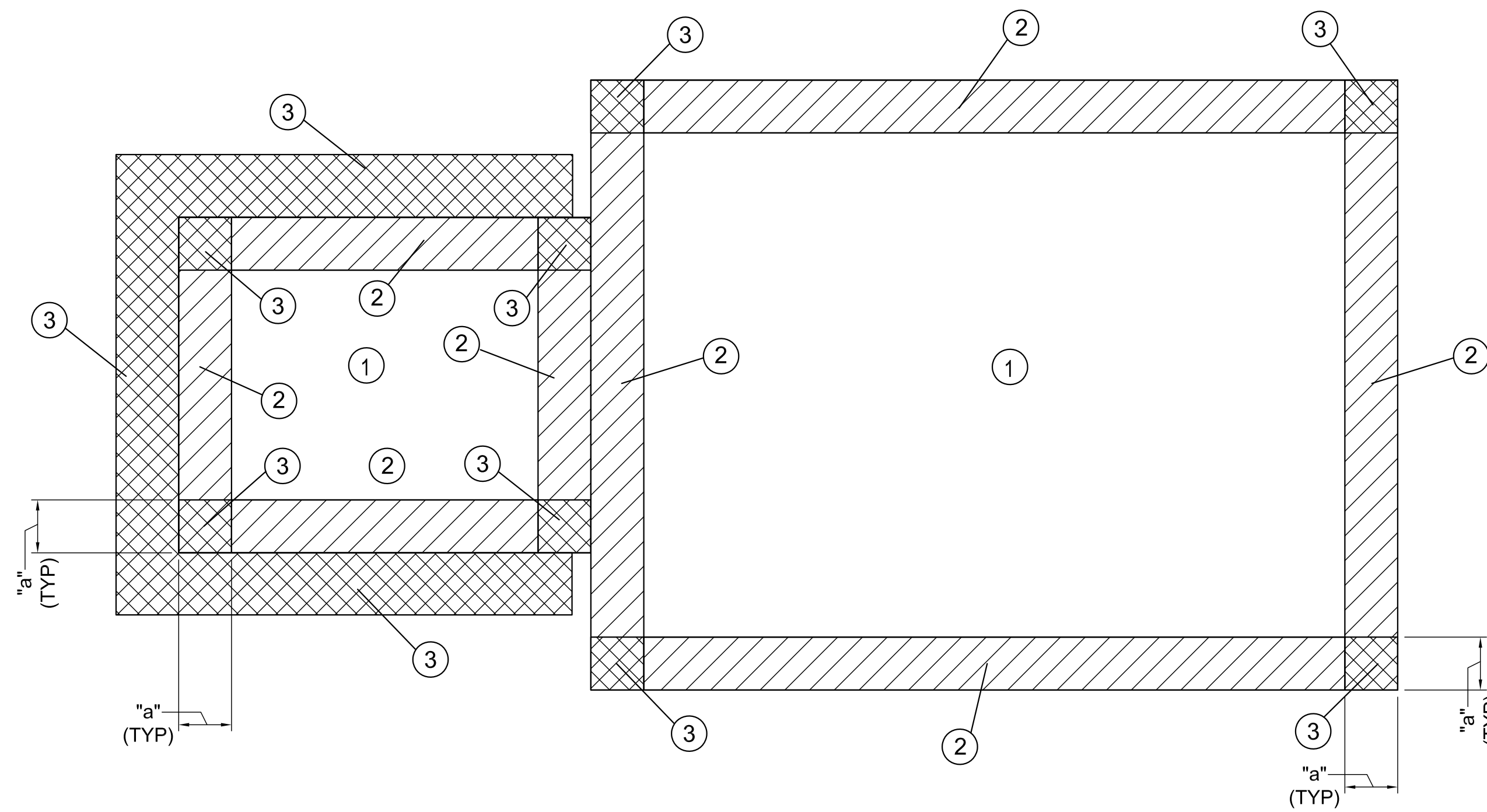

**1.4.4 DESIGN WIND PRESSURE - ROOF UPLIFT (ULTIMATE)**

COMPONENTS AND CLADDING SHALL BE DESIGNED FOR THE WIND PRESSURES SHOWN IN THE TABLE BELOW.

TRIBUTARY AREA	MAIN BUILDING ROOF						
	UPLIFT PRESSURE psf (ULTIMATE)						
	ZONE ①	ZONE ②	ZONE ③	a			
	T (PSF)	T (PSF)	T (PSF)	(FT)			
A $\leq 10$ ft <sup>2</sup>	+16	-35	+16	-59	+16	-89	11
A = 50 ft <sup>2</sup>	+16	-33	+16	-44	+16	-53	11
A $\geq 100$ ft <sup>2</sup>	+16	-32	+16	-38	+16	-38	11

"T" = TYPICAL ROOF AREA EXCLUDING OVERHANG

"+" = PRESSURES ACTING TOWARD SURFACES

"-" = PRESSURES ACTING AWAY FROM SURFACES

**1.5 SEISMIC LOAD (PER NCBC 2018, (IBC 2015, ASCE 7-10)**

**1.5.1 RISK CATEGORY:**

II (TABLE 1604.5)

**1.5.2 SEISMIC IMPORTANCE FACTOR:**

$I_e = 1.00$

**1.5.3 SPECTRAL ACCELERATION COEFFICIENTS:**

$S_s = 0.179$   $S_1 = 0.084$

**1.5.4 SPECTRAL RESPONSE COEFFICIENTS**

$S_{DS} = 0.191$   $S_{D1} = 0.134$

**1.5.5 SOIL SITE CLASS**

D (PER GEOTECHNICAL REPORT)

**1.5.6 BASIC SEISMIC-FORCE-RESISTING SYSTEM**

BUILDING FRAME / STRUCTURAL STEEL SYSTEMS NOT SPECIFICALLY DESIGNED FOR SEISMIC RESISTANCE

**1.5.7 DESIGN BASE SHEAR ANALYSIS PROCEDURE**

$V = 0.064 \times W$  KIPS = 31 KIPS  
EQUIVALENT LATERAL FORCE PROCEDURE, TABLE 1616.6.3

**1.5.8 SEISMIC DESIGN CATEGORY**

C

**1.5.9 SEISMIC RESPONSE COEFFICIENT**

$C_s = 0.064$

**1.5.10 RESPONSE MODIFICATION COEFFICIENT**

$R = 3$

**2.0 FOUNDATION DESIGN CRITERIA**

- 2.1 MINIMUM FOOTING BEARING DEPTH BELOW GRADE IS 18 INCHES.
- 2.2 MINIMUM FACTOR OF SAFETY FOR STABILITY AGAINST SLIDING, OVERTURNING AND UPLIFT FOR INDIVIDUAL COMPONENTS IS 1.5
- 2.3 ALLOWABLE SOIL BEARING CAPACITY = 2500 PSF (PER GEOTECHNICAL REPORT).

CONCRETE MATERIALS SCHEDULE		
STRUCTURAL ELEMENT	$f_c$ CONCRETE COMPRESSIVE STRENGTH @ 28 DAYS (PSI)	REMARKS
ALL FOOTINGS U.N.O.	3000	
SLAB-ON-GRADE	3500	
ALL OTHER CONCRETE	3500	

NOTES:  
1. ALL CONCRETE SHALL BE NORMAL WEIGHT CONCRETE. (150 PCF) (U.N.O.)

STEEL MATERIALS SCHEDULE		
STRUCTURAL ELEMENT	FY YIELD STRENGTH (KSI)	REMARKS
BEAMS & GIRDERS	50	ASTM A992
COLUMNS	50	ASTM A992
CONNECTIONS, PLATES, & ALL OTHERS	36	ASTM A36
ANCHOR BOLTS	36	ASTM F1554 GRADE 60
TUBING	46	ASTM A500 GRADE B

CONCRETE COVER SCHEDULE	
MINIMUM CONCRETE COVER PROTECTION FOR REINFORCEMENT BARS SHALL BE AS FOLLOWS: (SEE ACI 318-14, SECTION 20.6 FOR CONDITIONS NOT NOTED). DIMENSIONS FOR BAR PLACEMENT GIVEN IN SECTIONS AND DETAILS SHALL SUPERSEDE MINIMUM COVER REQUIREMENTS GIVEN HERE.	
FOOTINGS (EARTH FORMED)	3 INCHES
COLUMNS / PIERS	1 1/2 INCHES
GRADE BEAMS OR SLAB TURNED DOWN EDGES:	
TOP	1 1/2 INCHES
BOTTOM	3 INCHES
SIDES (EARTH FORMED)	3 INCHES
SIDES (BOARD FORMED)	1 1/2 INCHES
SLABS-ON-GRADE (NO EXPOSURE TO WEATHER) FROM TOP	3/4 INCHES
SLABS-ON-GRADE (EXPOSURE TO WEATHER) FROM TOP	1 1/2 INCHES
RETAINING WALLS (NO SURFACES SHALL BE EARTH FORMED)	
EARTH SIDE AND FRONT SIDE (EXPOSED TO WEATHER):	
#5 BAR AND SMALLER	1 1/2 INCHES
#6 THRU #11 BAR	2 INCHES
PROVIDE STANDARD BAR CHAIRS AND SPACERS AS REQUIRED TO MAINTAIN CONCRETE PROTECTION SPECIFIED.	

STANDARD HOOKS IN TENSION PER ACI 318-14)		
HOOK DEVELOPMENT LENGTH $l_{dh}$ (INCHES)		
BAR SIZE	$f_c$ 4000 PSI	$f_c$ 3000 PSI
#3	7	9
#4	10	11
#5	12	14
#6	15	17
#7	17	19
#8	19	22
#9	22	25
#10	24	28
#11	27	31

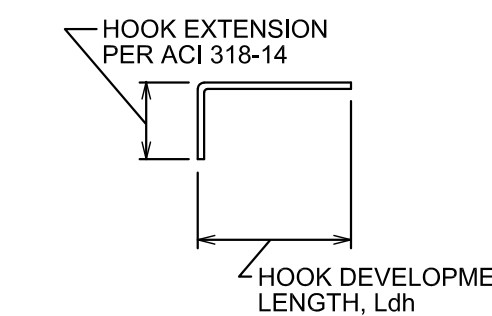

- NOTES:
- CONCRETE IS NORMAL WEIGHT CONCRETE.
  - BAR YIELD STRENGTH,  $f_y = 60$  KSI.
  - SIDE COVER REQUIREMENTS OF ACI SECT. 12.5.3.2 ARE ASSUMED TO NOT BE MET.
  - TIE OR STIRRUP REQUIREMENTS OF ACI SECT. 12.5.3.2 ARE ASSUMED TO NOT BE MET.
  - REDUCTION FOR EXCESS REINFORCEMENT IS NOT TAKEN.
  - HOOK DEVELOPMENT LENGTH IS VALID FOR 180° HOOKS ALSO.

MINIMUM LAP SPLICES OF REINFORCING BARS IN TENSION (PER ACI 318-14)									
BAR CONDITION	$f_c = 3000$ psi CONCRETE				$f_c = 3500$ psi CONCRETE				
	(TOP BARS)		(OTHER BARS)		(TOP BARS)		(OTHER BARS)		
	CATEGORY A	CATEGORY B	CATEGORY A	CATEGORY B	CATEGORY A	CATEGORY B	CATEGORY A	CATEGORY B	
#3	22"	32"	17"	25"	#3	20"	30"	16"	23"
#4	29"	43"	22"	33"	#4	27"	40"	21"	31"
#5	36"	54"	28"	41"	#5	33"	50"	26"	38"
#6	43"	64"	33"	50"	#6	40"	60"	31"	46"
#7	63"	94"	48"	72"	#7	58"	87"	45"	67"
#8	72"	107"	55"	82"	#8	66"	99"	51"	76"
#9	81"	121"	62"	93"	#9	75"	112"	58"	86"
#10	91"	136"	70"	105"	#10	84"	126"	65"	97"
#11	101"	151"	78"	116"	#11	93"	139"	72"	107"

NOTES:  
1. YIELD STRENGTH OF REINFORCEMENT,  $f_y$  IS 60 KSI (LAP SPLICE LENGTH IS IN INCHES).  
2. CONCRETE IS NORMAL WEIGHT (150 PCF).  
3. TOP BAR INDICATES HORIZONTAL REINFORCEMENT WHICH IS PLACED ABOVE 12" OR MORE OF FRESH CONCRETE.  
4. UNLESS NOTES OTHERWISE COLUMNS AND PIERS UTILIZE TENSION LAP SPLICES.  
5. CATEGORY "A" IN TABLE DENOTES BARS THAT HAVE CLEAR SPACING AND COVER AT LEAST  $4d$  AND STIRRUPS NOT LESS THAN CODE MIN. OR CLEAR SPACING GREATER THAN  $2d$  AND CLEAR COVER OF  $4d$ . CATEGORY "B" IS FOR ALL OTHER CASES.  
6. VALUES IN TABLES ARE FOR A CLASS "A" TENSION SPLICE. CLASS "B" TENSION SPLICE VALUES CAN BE OBTAINED BY MULTIPLYING THE VALUES FROM THE TABLE BY 1.3.

DRAWING NO. CFD-####-S-0002-44CC2B

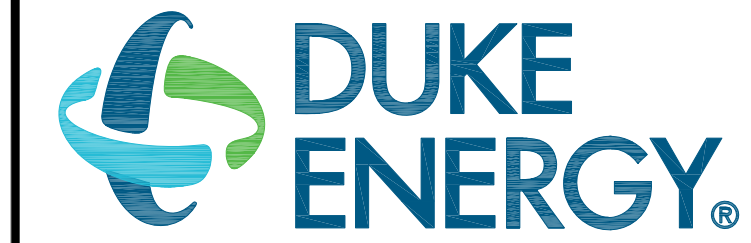

MAILING ADDRESS:  
P.O. BOX 1007  
CHARLOTTE, NC 28201

**Safety Expectations:**

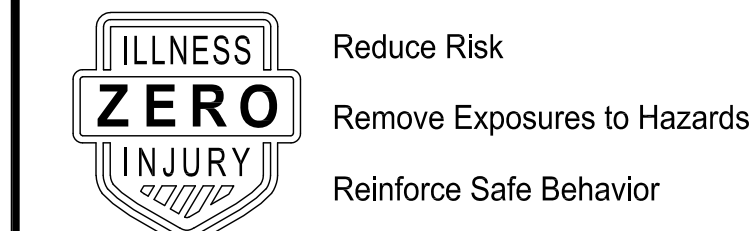

**MMSA, Inc.**

Michael M. Simpson & Associates, Inc.  
Consulting Structural Engineers  
30 Patewood Drive, Suite 100  
Greenville, S.C. 29615  
(864) 331-1201

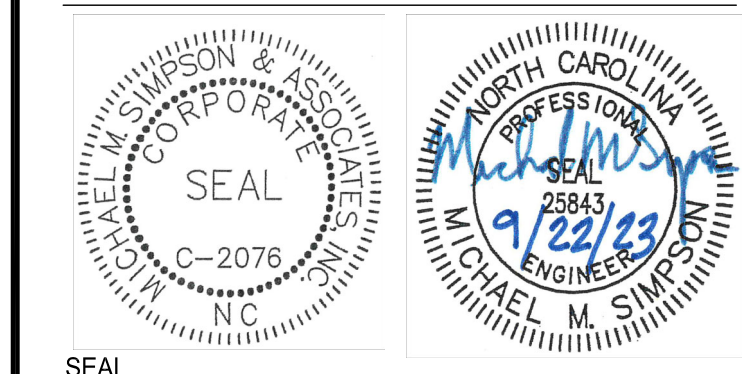

**DUNN OPERATIONS CENTER**

**OPERATIONS BUILDING**

REVISION	DATE	BY	CHK'D
1			
2			
3			
4			
5			
6			
7			
8			
9			
10			

PROJECT NO:  
DRAWING NUMBER  
CFD-####-S-0002-4122CB

ELECTRONIC FILE NAME: S0002.DWG

DRAWN BY: TML

CHK'D BY: MMS DATE: 09/22/2023

E-MAIL: msimpson@mmsainc.com

THIS DESIGN DRAWING IS THE EXCLUSIVE PROPERTY OF DUKE ENERGY CORPORATION AND IS CONSIDERED CONFIDENTIAL. IT SHALL NOT BE REPRODUCED, COPIED, OR DISTRIBUTED WITHOUT PRIOR APPROVAL. THIS INFORMATION SHOULD ONLY BE USED FOR THE SPECIFIC PROJECT INTENDED.

**SHEET TITLE: BASIS OF DESIGN**

SHEET NO.

**S-0002**

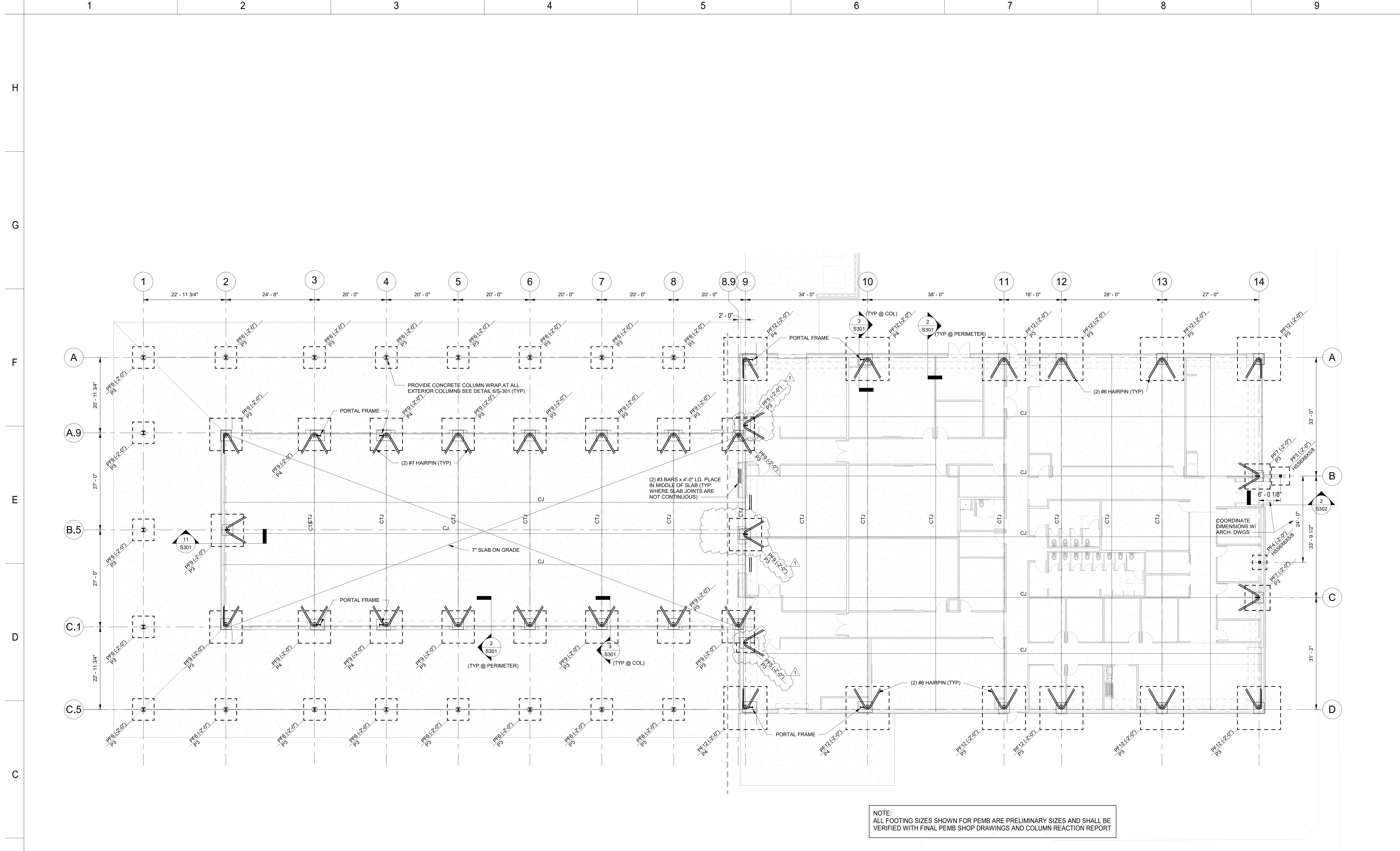

**1 OVERALL FOUNDATION SLAB PLAN**  
3/32" = 1'-0"

BUILDING FINISH FLOOR EL. 0'-0", WHICH EQUALS DATUM EL. ON THE CIVIL DWGS

SLAB-ON-GRADE = 4" CONCRETE SLAB REINF. W/ WWF 6x6xW2.9xW2.9 OVER 15 MIL VAPOR BARRIER AND 4" - #57 STONE BASE. (TYP @ OFFICE AREA, U.N.O.)

SLAB-ON-GRADE = 7" CONCRETE SLAB REINF. W/ #3 @ 12" O.C. EACH WAY (TOP & BOTT.) PLACED OVER 15 MIL VAPOR BARRIER. (TYP @ TRUCK BAYS AREA, U.N.O.)

CJ - INDICATES CONSTRUCTION JOINT, SEE DETAIL 1/S301  
CTJ - INDICATES CONTROL JOINT, SEE DETAIL 1/S301

- NOTES:**
- SEE DRAWING S301 - S302 FOR GENERAL NOTES AND BASIS OF DESIGN.
  - SEE ARCH. DRAWINGS FOR ALL BUILDING/WALL PLAN DIMENSIONS NOT SHOWN ON STRUCTURAL DWGS.
  - SEE ARCH. DRAWINGS FOR SLAB EDGE DIMENSIONS.
  - ALL FOOTINGS SHALL BE CENTERED ON COLUMNS, U.N.O.
  - CONTINUOUS WALL FOOTING REINFORCEMENT AND TURNED DOWN GRADE BEAMS, LONG-WAY BARS, SHALL BE CONTINUOUS THRU COLUMN FOOTINGS.
  - WHERE CONTINUOUS FOOTINGS OF DIFFERENT SIZES MERGE TOGETHER, THE SMALLER FOOTING LONG-WAY BARS SHALL EXTEND, (TENSION LAP SPLICE), INTO THE LARGER FOOTING.

- COORDINATE ALL SLAB RECESS LOCATIONS, SIZE AND DEPTHS W/ ARCH. DWGS.
- SEE PLUMBING DRAWINGS FOR ADD'L INFORMATION.
- PLACE CJ AT INTERIOR/EXTERIOR SLAB TRANSITION LOCATIONS.

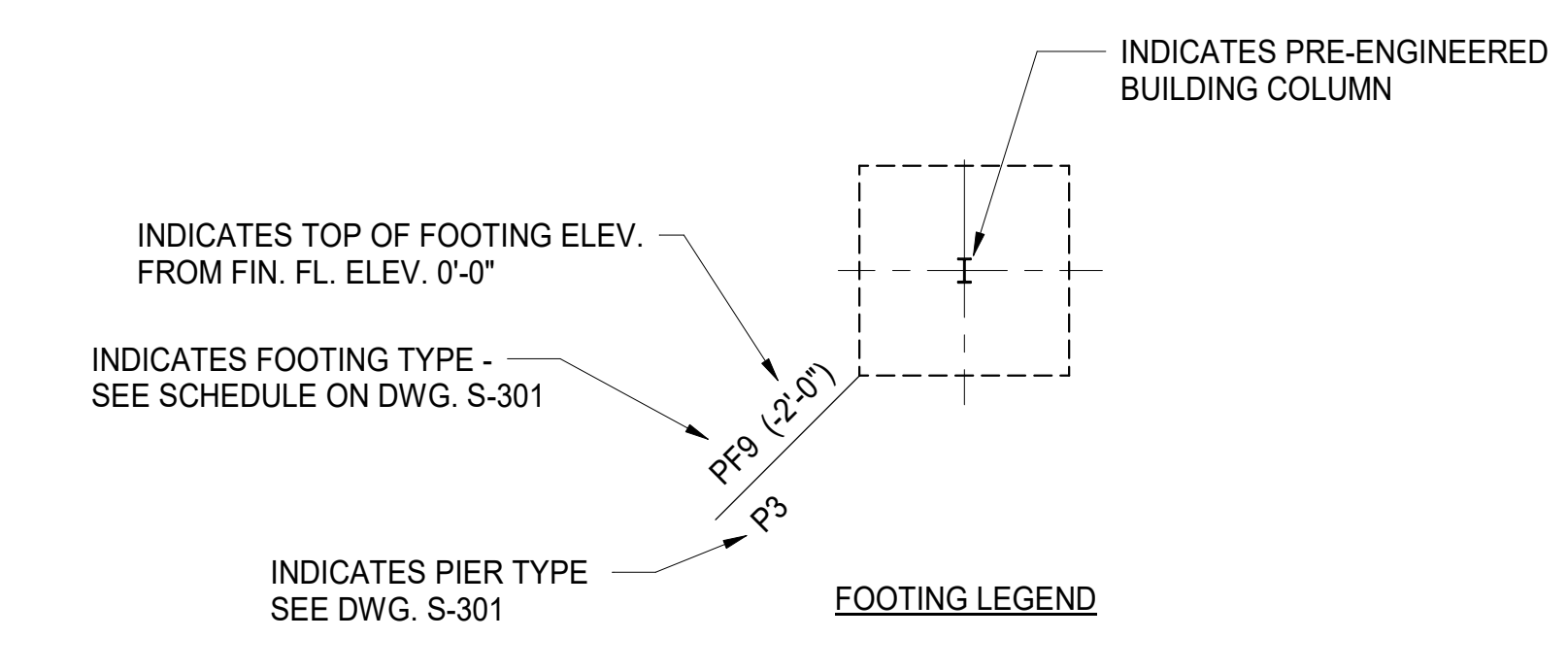

Autodesk Docs/9101-223870 Duke Energy Durrn Ops Center/Duke Energy - Durrn Ops Center\_S18.rvt 4/30/2024 5:09:24 PM

DRAWING NO.

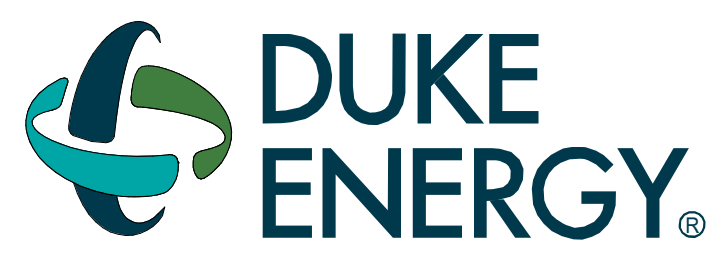

MAILING ADDRESS:  
P.O. BOX 1007  
CHARLOTTE, NC 28201

**Safety Expectations:**

**ILLNESS ZERO INJURY** Reduce Risk  
Remove Exposures to Hazards  
Reinforce Safe Behavior

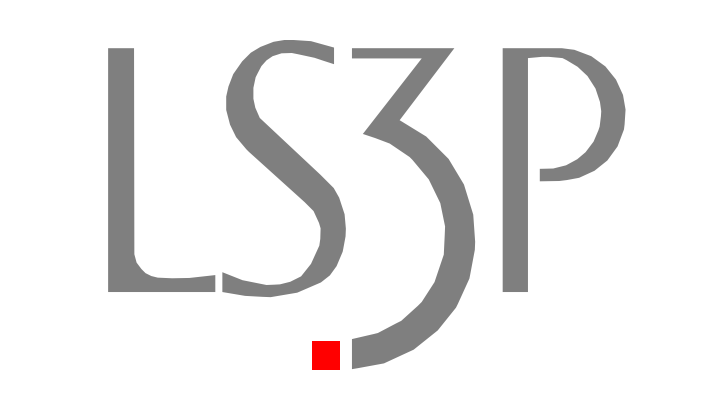

**MMSA, Inc.**  
Michael M. Simpson & Associates, Inc.  
Consulting Structural Engineers  
30 Patewood Drive, Suite 100  
Greenville, S.C. 29615  
(864) 331-1201

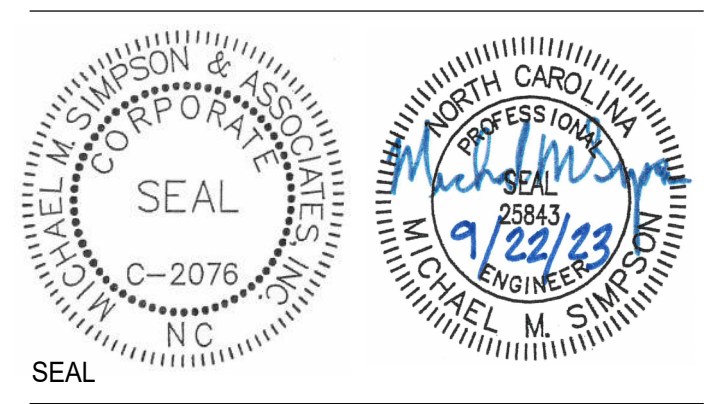

**DUKE OPERATIONS CENTER**

**OPERATIONS BUILDING**

MARK	DATE	DRN BY	REVISION
1	04-30-24		AST 03 - VE CHANGES
2			
3			
4			
5			
6			
7			
8			
9			

PROJECT NO: Project Number  
DRAWING NUMBER

ELECTRONIC FILE NAME:  
DRAWN BY: TML  
CHKD BY: MMS DATE: 09/23/2023

E-MAIL:  
THIS DESIGN DRAWING IS THE EXCLUSIVE PROPERTY OF DUKE ENERGY CORPORATION AND IS CONSIDERED CONFIDENTIAL. IT SHALL NOT BE MODIFIED, COPIED, OR DISTRIBUTED WITHOUT PRIOR APPROVAL. THIS INFORMATION SHOULD ONLY BE USED FOR THE SPECIFIC PROJECT INTENDED.

SHEET TITLE:  
**OVERALL FOUNDATION / SLAB PLAN**

SHEET NO.  
**SB-0110**





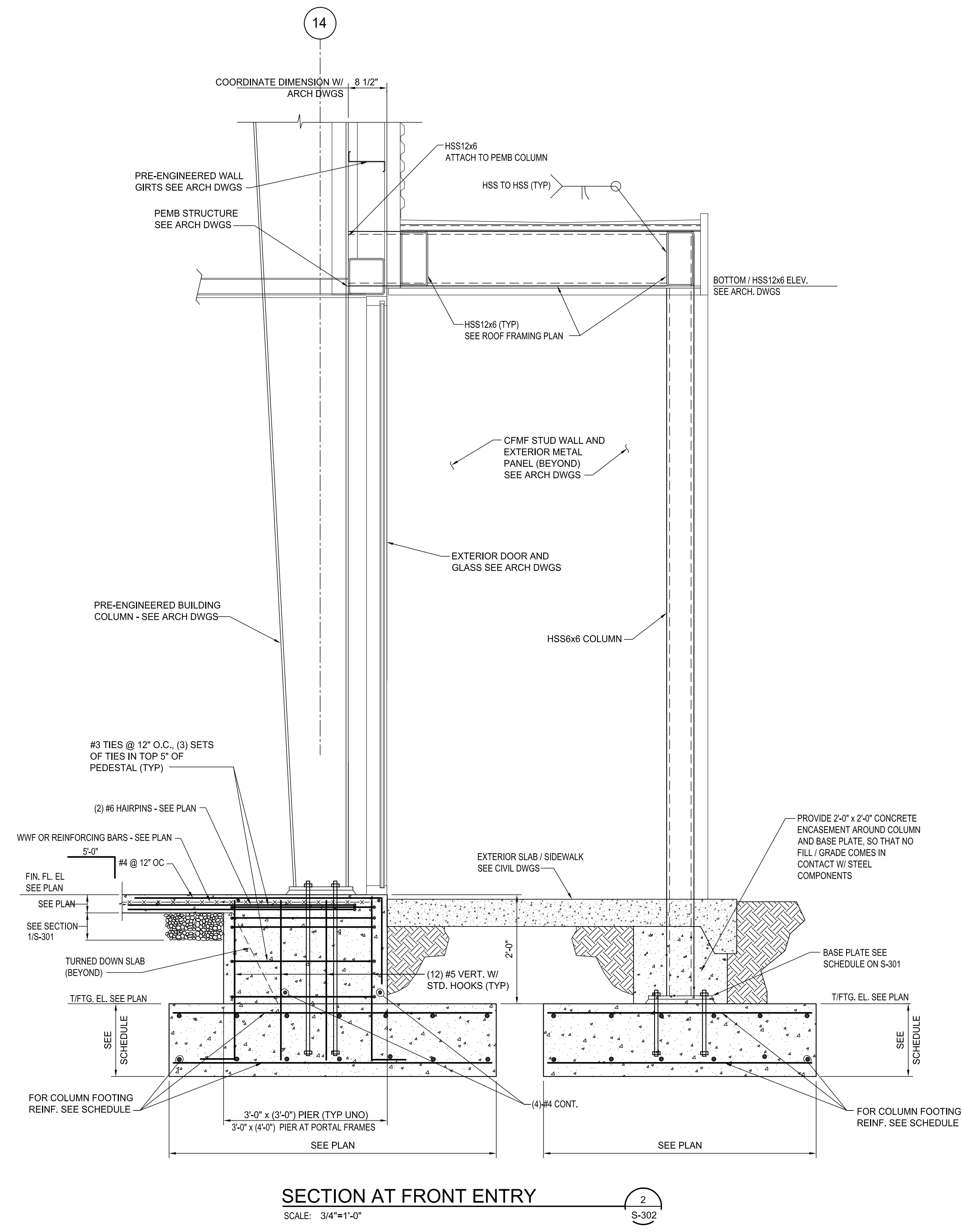
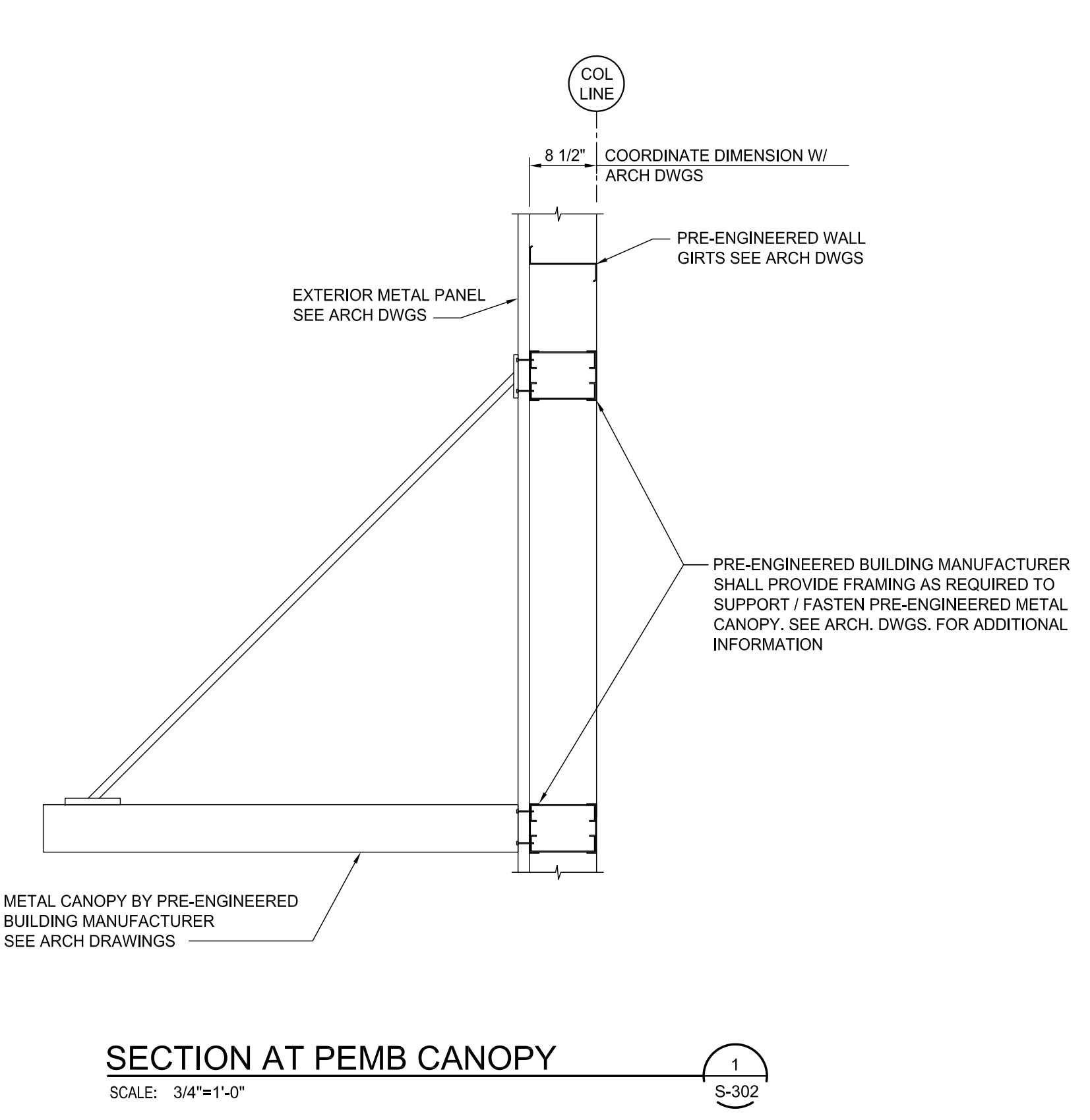

DRAWING NO.  
CFD-####-S-5002-44CC2B

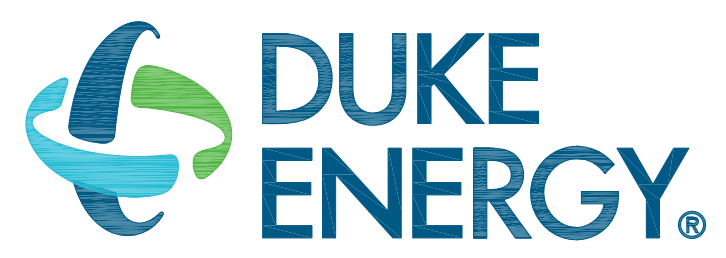

MAILING ADDRESS:  
P.O. BOX 1007  
CHARLOTTE, NC 28201

**Safety Expectations:**

**ILLNESS ZERO INJURY ZERO**

Reduce Risk  
Remove Exposures to Hazards  
Reinforce Safe Behavior



**MMSA, Inc.**  
Michael M. Simpson & Associates, Inc.  
Consulting Structural Engineers  
30 Patewood Drive, Suite 100  
Greenville, S.C. 29615  
(864) 331-1201

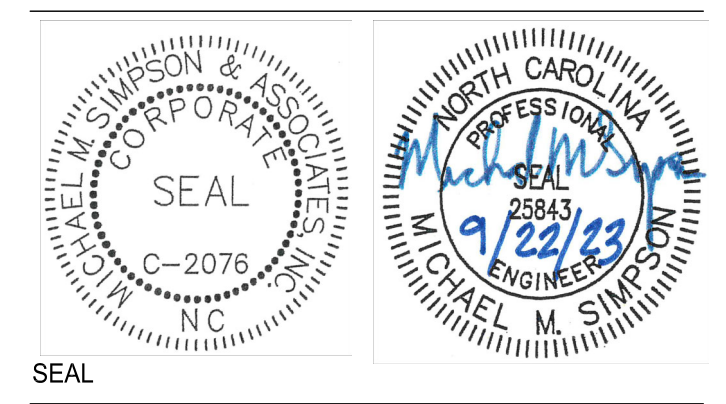

**DUKE OPERATIONS CENTER**

**OPERATIONS BUILDING**

REVISION	DATE	BY	CHK'D

PROJECT NO:  
DRAWING NUMBER  
CFD-####-S-5002-4122CB  
ELECTRONIC FILE NAME: S5002.DWG  
DRAWN BY: TML  
CHK'D BY: MMS DATE: 09/22/2023  
E-MAIL: msimpson@mmsainc.com

THIS DESIGN DRAWING IS THE EXCLUSIVE PROPERTY OF DUKE ENERGY CORPORATION AND IS CONSIDERED CONFIDENTIAL. IT SHALL NOT BE REPRODUCED, COPIED, OR DISTRIBUTED WITHOUT PRIOR APPROVAL. THIS INFORMATION SHOULD ONLY BE USED FOR THE SPECIFIC PROJECT INTENDED.

SHEET TITLE:  
**SECTIONS AND DETAILS**

SHEET NO.  
**S-302**