

DAWSON ELECTRIC

280 JARCO DRIVE

FUQUAY-VARINA, NORTH CAROLINA

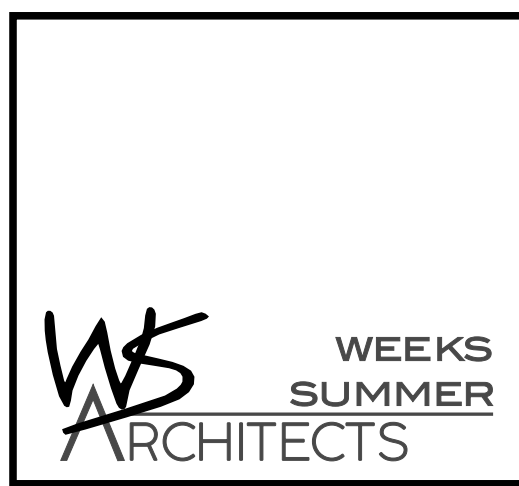

NC DEPT. OF INSURANCE 2018 APPENDIX B

BUILDING CODE SUMMARY FOR ALL COMMERCIAL PROJECTS
(EXCEPT 1 & 2-FAMILY DWELINGS AND TOWNHOUSES)
(REPRODUCE THE FOLLOWING DATON THE BUILDING PLANS SHEET 1 OR 2)

NC

Name Of Project: **DAWSON ELECTRIC**
Address: 280 JARCO DRIVE, FUQUAY-VARINA
Zip Code: 27526
Owner Or Authorized Agent: W. S. Architects, PA Phone: (919) 779-9797 E-mail: ginger@wsarchitectspa.com
Owned By: City/County Private State
Code Enforcement Jurisdiction: Town County - HARNETT CO. State

LEAD DESIGN PROFESSIONAL:	W. S. ARCHITECTS, PA
Designer	FIRM
Architectural:	W. S. Architects, PA
Civil	Ginger S. Sumner 11075 (919) 779-9797
Electrical:	Mullen Engineering Christopher B. Mullen 25582 (919) 906-0812 mullenbcm@embarqmail.com
Fire Alarm:	---
Plumbing:	Mullen Engineering Christopher B. Mullen 25582 (919) 906-0812 mullenbcm@embarqmail.com
Mechanical:	Mullen Engineering Christopher B. Mullen 25582 (919) 906-0812 mullenbcm@embarqmail.com
Sprinkler-Standpipe:	---
Structural:	---
Retaining Walls	---
> 5 High:	---
Other:	---

2018 NC BUILDING CODE: New Building Shell/Core 1st Time Interior Completions
 Addition Phased Construction - Shell Core
2018 NC EXISTING BUILDING CODE: Prescriptive Alteration Level I Historic Property
 Repair Alteration Level II Change of Use
 Chapter 14 Alteration Level III
CONSTRUCTED: (date) _____ CURRENT OCCUPANCY(S) (Ch. 3): vacant
RENOVATED: (date) _____ PROPOSED OCCUPANCY(S) (Ch. 3): B, S1
OCCUPANCY CATEGORY (Table 1604.5): Current: II Proposed: II

BASIC BUILDING DATA
CONSTRUCTION TYPE: I-A I-B II-A II-B III-A III-B IV V-A V-B
SPRINKLERS: NO PARTIAL NFPA 13 NFPA 13R NFPA 13D
STANDPIPES: NO CLASS I II III WET DRY
PRIMARY FIRE DISTRICT: NO YES FLOOD HAZARD AREA: NO YES
SPECIAL INSPECTIONS REQUIRED: NO YES

GROSS BUILDING AREA	EXISTING (SF)	NEW (SF)	SUB-TOTAL	TENANT
3RD FLOOR	---	---	---	---
2ND FLOOR	---	---	---	---
MEZZANINE	---	---	---	---
1ST FLOOR	6,053	---	---	---
BASEMENT	---	---	---	---
TOTAL	6,053	---	---	---

ALLOWABLE AREA:
PRIMARY OCCUPANCY: ASSEMBLY BUSINESS EDUCATIONAL FACTORY HIGH-HAZARD INSTITUTIONAL
 MERCANTILE RESIDENTIAL STORAGE
 UTILITY & MISCELLANEOUS

ACCESSORY OCCUPANCY CLASSIFICATION(S): _____
INCIDENTAL USES (Table 509): _____
SPECIAL USES (Chapter 4 - List Code Sections): _____
SPECIAL PROVISIONS (Chapter 5 - List Code Sections): _____
MIXED OCCUPANCY: Select one Separation: Select one Exception: _____

STORY NO.	DESCRN AND USE	(A) BLDG AREA PER STORY (ACTUAL)	(B) TABLE 506.2 AREA	(C) AREA FOR OPEN SPACE INCREASE 1,3	(D) ALLOWABLE AREA OR UNLIMITED 2,3
1	B	2,940	23,000	17,250	40,250
1	S-1	3,113	17,500	13,125	30,625
---	---	---	---	---	---

- Frontage Area Increases From Section 506.2 Are Computed Thus:
A. Perimeter Which Fronts A Public Way Or Open Space Having 20 Ft Min. Width = _____ (F).
B. Total Building Perimeter = _____ (P).
C. Ratio (F/P) = _____ (F/P).
D. W = Minimum Width Of Public Way = --- (W)
- Unlimited area applicable under conditions of Section 507
- Max. Building Area = Total No. Of Stories In The Building X D (maximum 3 stories) (506.2)
- The Maximum Area Of Open Parking Garages Must Comply With 406.5.4. The Maximum Area Of Air Traffic Control Towers Must Comply With 412.3.1.
- Frontage increase is based on the unspinklered area value in Table 506.2.

ALLOWABLE HEIGHT	ALLOWABLE (TABLE 503)	SHOWN ON PLANS	CODE REFERENCE
BUILDING HEIGHT IN FEET	55 (FT)	24 (FT)	---
BUILDING HEIGHT IN STORIES	2 (STORIES)	1 (STORIES)	---

1. Provide code reference if the "Shown on Plans" quantity is not based on Table 504.3 or 504.4.

NC DEPT. OF INSURANCE 2018 APPENDIX B

BUILDING CODE SUMMARY CONTINUED

BUILDING ELEMENT	FIRE SEPN DIST. (FT)	RATING REQ'D	RATING PROV'D (W/ REDUCTION)	DETAIL # AND SHEET #	DES. # FOR RATED ASSY	DES. # FOR RATED PENETN	DES. # FOR RATED JOINTS
STRUCTURAL FRAME, INCLUDING COLUMNS, GIRDERS, TRUSSES	≥ 30'	0	0	---	---	---	---
BEARING WALLS	---	---	---	---	---	---	---
EXTERIOR	---	---	---	---	---	---	---
NORTH	≥ 30'	---	---	---	---	---	---
EAST	≥ 30'	---	---	---	---	---	---
WEST	≥ 30'	---	---	---	---	---	---
SOUTH	≥ 30'	---	---	---	---	---	---
INTERIOR	---	---	---	---	---	---	---
NONBEARING WALLS AND PARTITIONS	---	---	---	---	---	---	---
EXTERIOR	---	---	---	---	---	---	---
NORTH	≥ 30'	0	0	---	---	---	---
EAST	≥ 30'	0	0	---	---	---	---
WEST	≥ 30'	0	0	---	---	---	---
SOUTH	≥ 30'	0	0	---	---	---	---
INTERIOR WALL & PARTITIONS	---	---	---	---	---	---	---
FLOOR CONSTRUCTION INCLUDING SUPPORTING BEAMS AND JOISTS	---	---	---	---	---	---	---
FLOOR CEILING ASSEMBLY	---	---	---	---	---	---	---
COLUMNS SUPPORTING FLOORS	---	---	---	---	---	---	---
ROOF CONSTRUCTION INCLUDING SUPPORTING BEAMS AND JOISTS	---	---	---	---	---	---	---
ROOF CEILING ASSEMBLY	---	---	---	---	---	---	---
COLUMNS SUPPORTING ROOF	---	---	---	---	---	---	---
SHAFTS ENCLOSURES-EXIT	---	---	---	---	---	---	---
SHAFTS ENCLOSURES-OTHER	---	---	---	---	---	---	---
CORRIDOR SEPARATION	---	---	---	---	---	---	---
OCCUPANCY/FIRE BARRIER SEPARATION	---	---	---	---	---	---	---
PARTY/FIRE WALL SEPARATION	0	0	---	---	---	---	---
SMOKE BARRIER SEPARATION	0	0	---	---	---	---	---
SMOKE PARTITION	*	*	---	---	---	---	---
TENANT/DWELLING UNIT/SLEEPING UNIT SEPARATION	0	0	---	---	---	---	---
INCIDENTAL USE SEPARATION	---	---	---	---	---	---	---

*INDICATE SECTION NO. PERMITTING REDUCTION *exist. sep. wall no longer req'd

FIRE SEPARATION DISTANCE (FEET) FROM PROPERTY LINES	DEGREE OF OPENINGS PROTECTION (TABLE 705.8)	ALLOWABLE AREA (%)	ACTUAL SHOWN ON PLANS (%)
---	---	---	---
---	---	---	---
---	---	---	---
---	---	---	---

LIFE SAFETY SYSTEM REQUIREMENTS
EMERGENCY LIGHTING: YES NO SMOKE DETECTION SYSTEMS: YES NO
FIRE ALARM: YES NO PANIC HARDWARE: YES NO

LIFE SAFETY PLAN REQUIREMENTS SHEET NUMBER A0.2
 FIRE AND/OR SMOKE RATED WALL LOCATIONS (CHAPTER 7)
 ASSUMED AND REAL PROPERTY LINE LOCATIONS (IF NOT ON SITE PLAN)
 EXTERIOR WALL OPENING AREA WITH RESPECT TO DISTANCE TO ASSUMED PROPERTY LINES (705.8)
 OCCUPANCY USE FOR EACH AREA AS IT RELATES TO OCCUPANT LOAD CALCULATION (TABLE 1004.1.2)
 OCCUPANT LOADS FOR EACH AREA
 EXIT ACCESS TRAVEL DISTANCES (1017)
 COMMON PATH OF TRAVEL DISTANCES (1006.2.1 & 1006.3.2(1))
 DEAD END LENGTHS (1024)
 CLEAR EXIT WIDTHS FOR EACH EXIT DOOR
 MAXIMUM CALCULATED OCCUPANT LOAD CAPACITY EACH EXIT DOOR CAN ACCOMMODATE BASED ON EGRESS WIDTH (1005.3)
 ACTUAL OCCUPANT LOAD FOR EACH DOOR
 A SEPARATE SCHEMATIC PLAN INDICATING WHERE FIRE RATED FLOOR/CEILING AND/OR ROOF STRUCTURE IS PROVIDED FOR PURPOSES OF OCCUPANCY SEPARATION
 LOCATION OF DOORS WITH PANIC HARDWARE (1010.1.10)
 LOCATION OF DOORS WITH DELAYED EGRESS LOCKS AND THE AMOUNT OF THE DELAY (1010.1.9.7)
 LOCATION OF DOORS WITH ELECTROMAGNETIC EGRESS LOCKS (1010.1.9.9)
 LOCATION OF DOORS EQUIPPED WITH HOLD-OPEN DEVICES
 LOCATION OF EMERGENCY ESCAPE WINDOWS (1030)
 THE SQUARE FOOTAGE OF EACH FIRE AREA (202)
 THE SQUARE FOOTAGE OF EACH SMOKE COMPARTMENT FOR OCCUPANCY CLASSIFICATION I-2 (407.5)
 NOTE ANY CODE EXCEPTIONS ON TABLE NOTES THAT MAY HAVE BEEN UTILIZED REGARDING THE ITEMS ABOVE

TOTAL UNITS	ACCESSIBLE UNITS REQ'D	ACCESSIBLE UNITS PROV'D	TYPE A UNITS REQ'D	TYPE A UNITS PROV'D	TYPE B UNITS REQ'D	TYPE B UNITS PROV'D	TOTAL ACCESSIBLE UNITS PROV'D
---	---	---	---	---	---	---	---

LOT OR PARKING AREA	REQ'D	PROVID'D	REG. WITH 5' ACCESS AISLE	132' ACCESS AISLE	8' ACCESS AISLE	TOTAL # ACCESSIBLE PROVIDED
---	---	---	---	---	---	---
TOTAL	---	---	---	---	---	---

USE	WATERCLOSETS	LAVATORIES	SHOWERS/TUBS	DRINKING FOUNTAINS					
	MALE	FEMALE	UNISEX	URINALS	MALE	FEMALE	UNISEX	REGULAR	ACCESSIBLE
SPACE	---	---	---	---	---	---	---	---	---
EXIST'G	---	---	---	---	---	---	---	---	---
NEW REQ'D	---	---	1	---	---	---	1	---	---

SPECIAL APPROVALS
Special Approval: (Local Jurisdiction, Dept of Insurance, OSC, DPI, DHHS, etc., describe below)

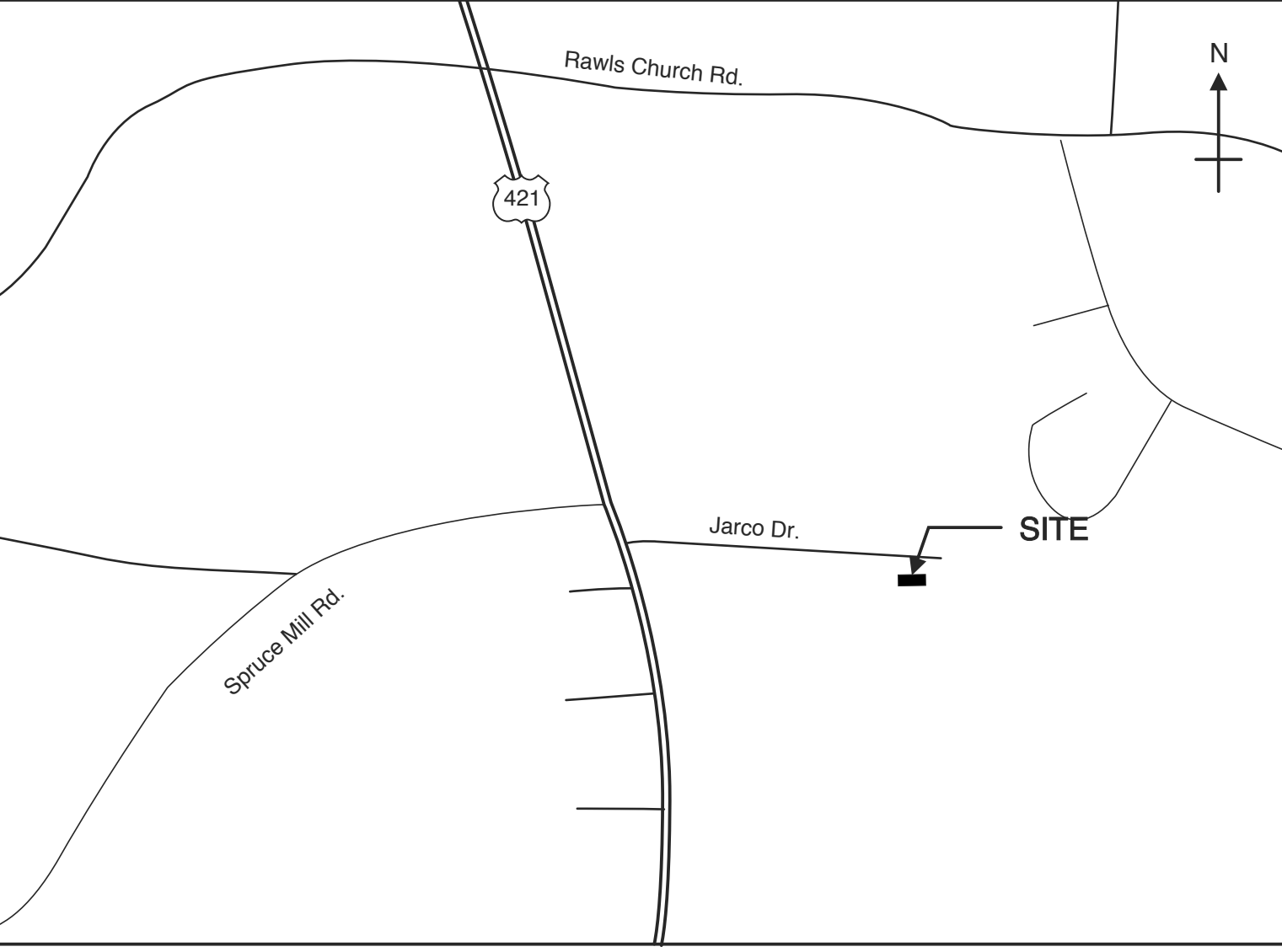

NC DEPT. OF INSURANCE 2018 APPENDIX B

BUILDING CODE SUMMARY CONTINUED

ENERGY SUMMARY EXISTING TO REMAIN

ENERGY REQUIREMENTS:
The following data shall be considered minimum and any special attribute required to meet the energy code shall also be provided. Each Designer shall furnish the required portions of the project information for the plan data sheet. If performance method, state the annual energy cost for the standard reference design vs annual cost for the proposed design.

Existing building envelope complies with code: _____
Exempt Building: _____ Provide code or statutory reference: _____
Climate Zone: _____
Method of Compliance: (If "Other" specify source here) _____

THERMAL ENVELOPE (Prescriptive method only)
Roof/Ceiling Assembly (each assembly)
Description of assembly _____
U-Value of total assembly _____
R-Value of insulation _____
Skylights in each assembly _____
U-Value of skylight _____
Total square footage of skylights in each assembly _____

Exterior Walls (each assembly)
Description of assembly _____
U-Value of total assembly _____
R-Value of insulation _____
Openings (windows or doors with glazing)
U-Value of assembly _____
Solar heat gain coefficient _____
Projection factor _____
Door R-Values _____

Walls below grade (each assembly)
Description of assembly _____
U-Value of total assembly _____
R-Value of insulation _____

Floors over unconditioned space (each assembly)
Description of assembly _____
U-Value of total assembly _____
R-Value of insulation _____

Floors slab on grade
Description of assembly _____
U-Value of total assembly _____
R-Value of insulation _____
Horizontal/Vertical requirement _____
Slab heated _____

STRUCTURAL DESIGN (PROVIDE ON SHEET 1 OR 2 OF THE STRUCTURAL SHEETS)
DESIGN LOADS: EXISTING TO REMAIN

IMPORTANCE FACTORS: WIND (I W) --- SNOW (I S) --- SEISMIC (I E) ---
LIVE LOADS: ROOF --- psf MEZZANINE --- psf FLOOR --- psf
GROUND SNOW LOAD: --- psf
WIND LOAD: BASIC WIND SPEED --- mph (ASCE-7) EXPOSURE CATEGORY ---

SEISMIC DESIGN CATEGORY A B C D
PROVIDE THE FOLLOWING SEISMIC DESIGN PARAMETERS:
OCCUPANCY CATEGORY (TABLE 1604.5) I II III IV
SPECTRAL RESPONSE ACCELERATION S_s --- %g S_1 --- %g S_2 --- %g
SITE CLASSIFICATION (ASCE 7) A B C D
--- Field Test --- Presumptive --- Historical Data
BASIC STRUCTURAL SYSTEM (check one)
--- BEARING WALL --- DUAL W/SPECIAL MOMENT FRAME
--- BUILDING FRAME --- DUAL WINTERMEDIATE R/C OR SPECIAL STEEL
--- MOMENT FRAME --- INVERTED PENDULUM
ANALYSIS PROCEDURE --- SIMPLIFIED --- EQUIVALENT LATERAL FORCE --- DYNAMIC
ARCHITECTURAL, MECHANICAL, COMPONENTS ANCHORED YES NO
LATERAL DESIGN CONTROL: EARTHQUAKE WIND
SOIL BEARING CAPACITIES:
FIELD TEST (PROVIDE COPY OF TEST REPORT) --- psf
PRESUMPTIVE BEARING CAPACITY --- psf
PILE SIZE, TYPE, AND CAPACITY _____

NC DEPT. OF INSURANCE 2018 APPENDIX B

BUILDING CODE SUMMARY CONTINUED

MECHANICAL DESIGN (PROVIDE ON THE MECHANICAL SHEETS IF APPLICABLE)
MECHANICAL SUMMARY: _____

THERMAL ZONE: _____
INTERIOR DESIGN CONDITIONS: _____
BUILDING HEATING LOAD: _____
BUILDING COOLING LOAD: _____

ELECTRICAL DESIGN (PROVIDE ON THE ELECTRICAL SHEETS IF APPLICABLE)

METHOD OF COMPLIANCE: (SELECT ONE)

LIGHTING SCHEDULE (each fixture type)
LAMP TYPE REQUIRED IN FIXTURE _____
NUMBER OF LAMPS IN FIXTURE _____
BALLAST TYPE USED IN THE FIXTURE _____
NUMBER OF BALLASTS IN FIXTURE _____
TOTAL WATTAGE PER FIXTURE _____
TOTAL INTERIOR WATTAGE SPECIFIED VS. ALLOWED (whole building or space by space) _____
TOTAL EXTERIOR WATTAGE SPECIFIED VS. ALLOWED _____

ADDITIONAL PRESCRIPTIVE COMPLIANCE
 506.2.1 MORE EFFICIENT MECHANICAL EQUIPMENT
 506.2.2 REDUCED LIGHTING POWER DENSITY
 506.2.3 ENERGY RECOVERY VENTILATION SYSTEMS
 506.2.4 HIGHER EFFICIENCY SERVICE WATER HEATING
 506.2.5 ON-SITE SUPPLY OF RENEWABLE ENERGY
 506.2.6 AUTOMATIC DAYLIGHTING CONTROL SYSTEMS

W. S. ARCHITECTS, PA
3305-109 Durham Drive
Raleigh, North Carolina 27603
919.779.9797
www.wsarchitectspa.com

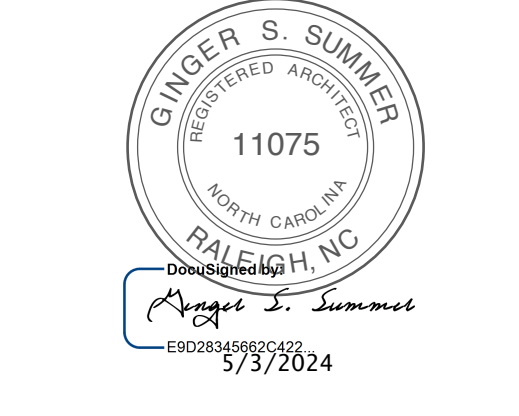

3/3/2024

PROJECT TITLE
DAWSON'S ELECTRIC
280 JARCO DRIVE
FUQUAY-VARINA, NC

PROJECT NO.
2300f

DRAWING TITLE
COVER SHEET

SHEET 1 OF 4

A0.1

PLOT DATE 5/3/24
REVISION _____

This original sheet is 24" x 36", other dimensions indicate it has been altered.
All information on this sheet is the property of W. S. Architects, PA and may not be duplicated in whole or in part without written authorization from W. S. Architects, PA. 2020 ©

DOOR SCHEDULE							
MARK	DOOR			FRAME			REMARKS
	SIZE	MAT'L	TYPE	MAT'L	DETAILS	HDWR	
1	3'-0" x 7'-0" x 1-3/4"	existing	---	---	---	---	---
2	3'-0" x 7'-0" x 1-3/4"	existing	---	---	---	---	---
3	3'-0" x 7'-0" x 1-3/4"	existing	---	---	---	---	---
4	3'-0" x 7'-0" x 1-3/4"	existing	---	---	---	---	---
5	3'-0" x 7'-0" x 1-3/4"	existing	---	---	---	---	RELOCATED
6	3'-0" x 7'-0" x 1-3/4"	SC WD	---	HM	---	1	---
7	3'-0" x 7'-0" x 1-3/4"	SC WD	---	---	---	1	---
8	3'-0" x 7'-0" x 1-3/4"	SC WD	---	---	---	2	---
9	3'-0" x 7'-0" x 1-3/4"	SC WD	---	---	---	3	---
10	3'-0" x 7'-0" x 1-3/4"	SC WD	---	---	---	4	---
11	3'-0" x 7'-0" x 1-3/4"	SC WD	---	---	---	5	---

NOTES:
- CONFIRM HARDWARE WITH OWNER

DOOR HARDWARE	NOTES:
1. PASSAGE SET WITH CLOSER	- COORDINATE KEYING OF HARDWARE WITH OWNER
2. PASSAGE SET WITH CLOSER	- DOOR HANDLES TO BE SCHLAGE ND-SERIES, FINISH-BR. NICKEL
3. PUSH/PULL WITH CLOSER	- DOOR HINGES TO BE IVES 5BB1/HW OR APPROVED EQUAL
4. PRIVACY	- DOOR CLOSERS TO BE LCN 4040 SERIES OR EQUAL
5. LOCKSET	- DOOR SLABS TO BE PREFINISHED CLEAR GRADE, WHITE PLAIN SLICED BIRCH UNO
	- WALL OR FLOOR STOPS TO BE PROVIDED
	- DOOR SILENCERS TO BE PROVIDED
	- PROVIDE DRIP FLASHING AT EXTERIOR DOORS AS REQUIRED
	- REPLACE ALL WEATHERSTRIPPING AT EXISTING EXT. DOORS

ROOM FINISH SCHEDULE									
MARK	ROOM NAME	FLOOR	BASE	WALL			CEILING		REMARKS / NOTES
				N	E	S	W	WAINSCOT	
101	LOBBY	LVT	RUBBER	PTD. DW.	---	---	ACC TILE	9'-0"	---
102	REST ROOM	LVT	RUBBER	PTD. DW.	---	---	ACC TILE	9'-0"	---
103	OFFICE	LVT	RUBBER	PTD. DW.	---	---	ACC TILE	9'-0"	---
104	OFFICE	LVT	RUBBER	PTD. DW.	---	---	ACC TILE	9'-0"	---
105	WAREHOUSE	EX CONC.	RUBBER	PTD. DW.	---	---	---	---	DW & BASE ONLY AT NEW WALL
106	MEETING SPACE	LVT	RUBBER	PTD. DW.	---	---	ACC TILE	9'-0"	---
107	COFFEE	LVT	RUBBER	PTD. DW.	---	---	ACC TILE	9'-0"	---
108	WAREHOUSE	EX CONC.	RUBBER	PTD. DW.	---	---	---	---	DW & BASE ONLY AT NEW WALL

ALL REMAINING SPACES ARE EXISTING TO REMAIN

NOTES:
-REPAIR ANY EXISTING FINISHES TO REMAIN
-CONFIRM ALL FINISHES WITH TENANT.
-EPOXY PAINT ON WET WALLS
-USE MOLD/MOISTURE RESISTANT SHEETROCK ON WALLS OF ALL RESTROOMS THAT DO NOT RECIEVE TILE.
-LVT TO BE WATER PROOF WITH 20 MIL MIN WEAR LAYER. COLOR TO BE DETERMINED.
-LVT TRANSITIONS WITH NO-LIP RAMP AT DOOR OPENINGS (BLAKELY LVT125 OR EQUAL)

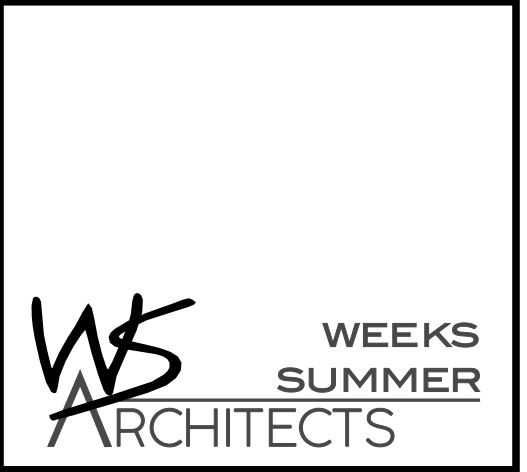

W. S. ARCHITECTS, PA
3305-109 Durham Drive
Raleigh, North Carolina 27603
919.779.9797
www.wsarchitectspa.com

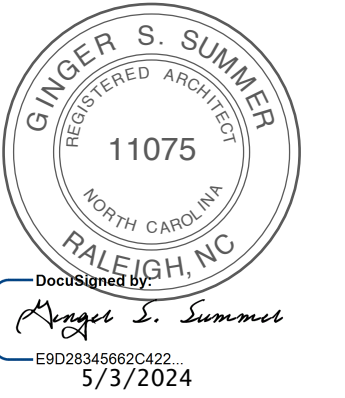

EGRESS REQ. & CODE REF.

DOORS TO HAVE 32" MIN. CLR. PER 404.2.2 OF ANSI A117.1

THE CLEAR WIDTH OF INTERIOR ACCESSIBLE ROUTE IS 36" MIN. PER 403.5 OF ANSI A117.1

CORRIDOR WIDTH MINIMUM IS 44" CLR. PER TABLE 1020.2

COMMON PATH OF TRAVEL = 75' MAX.
MAX. TRAVEL DIST. = 200'

LEGEND

---> EGRESS PATH

FE FIRE EXTINGUISHER-HANDLE OF EXT. 48" AFF MAX. VERIFY LOCATION WITH FIRE MARSHALL

OCCUPANT LOAD

UNCONCENTRATED ASSEMBLY
435 sf net/15 sf/pp 29

STORAGE AREA
3,110 sf gross/ 500 sf/pp 7

BUSINESS AREA
2,221sf gross/100 sf/pp 23

TOTAL = 59
59/2 exits = 30 each

EGRESS WIDTH
35 x 0.2 = 7 in. clr

PLUMBING COUNT

REQUEST 60% MALES/ 40% FEMALES
NON PROPORTIONAL DIST. PER 403.1.1 EX 1
EMPLOYEE ROSTER AVAILABLE FOR REVIEW

MALES
35
1 WC + 1 URINAL
1 LAV

FEMALES
24
1 WC
1 LAV

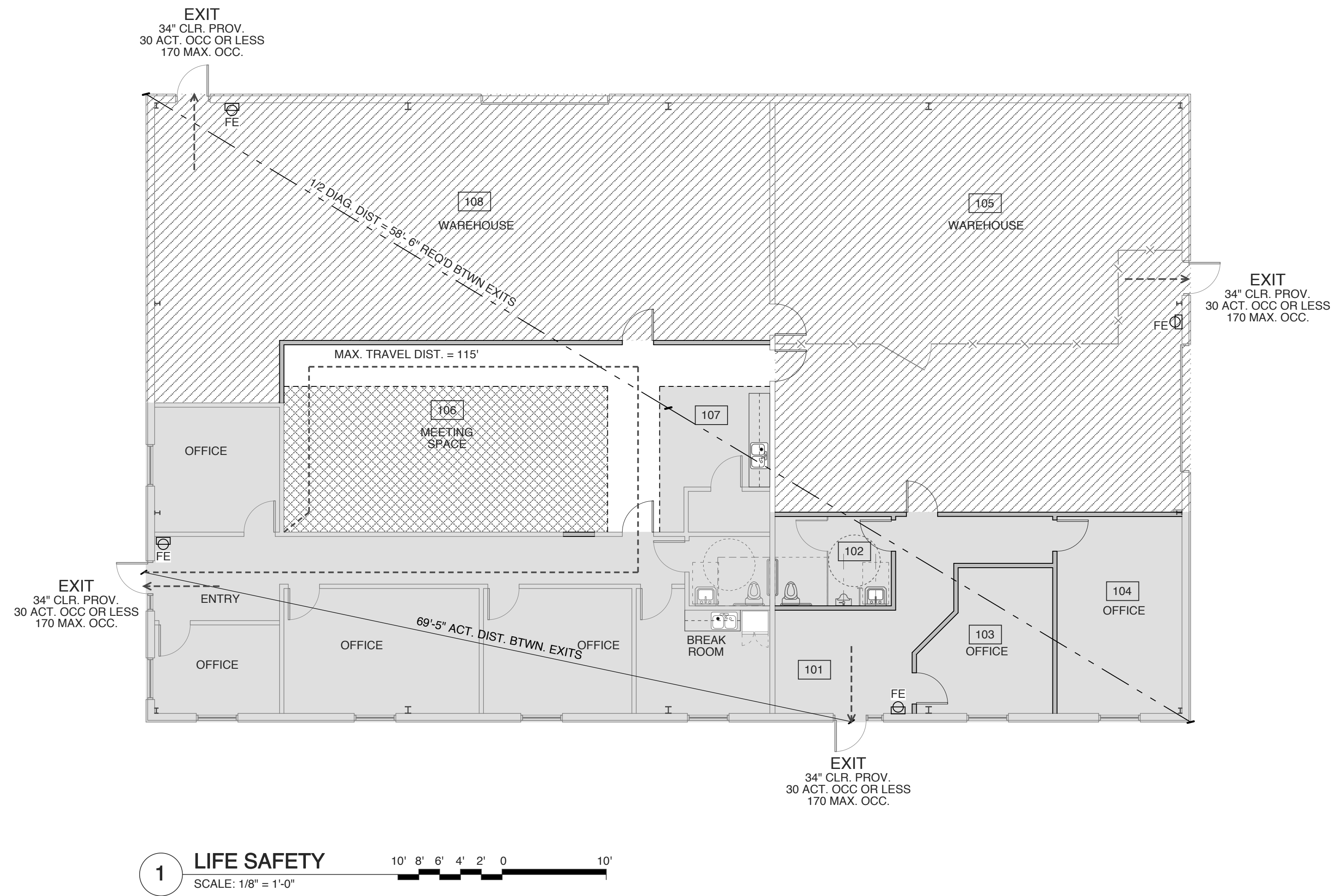

PROJECT TITLE
DAWSON'S ELECTRIC
280 JARCO DRIVE
FUQUAY-VARINA, NC

PROJECT NO.
2300f

DRAWING TITLE
LIFE SAFETY

SHEET 2 OF 4

A0.2

PLOT DATE 5/3/24
REVISION ---

This original sheet is 24" x 36", other dimensions indicate it has been altered.

All information on this sheet is the property of W. S. Architects, PA and may not be duplicated in whole or in part without written authorization from W. S. Architects, PA. 2020 ©

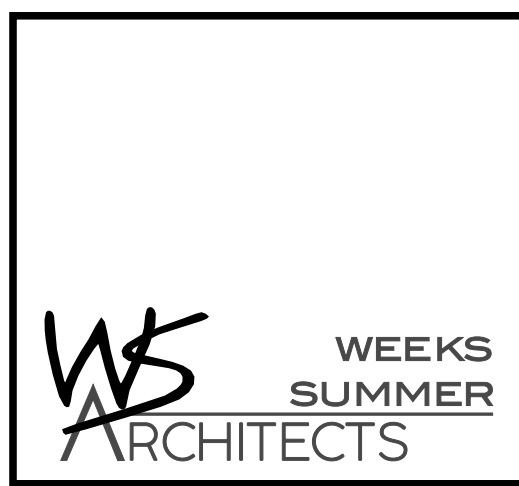

W. S. ARCHITECTS, PA
3305-109 Durham Drive
Raleigh, North Carolina 27603
919.773.9797
www.wsarchitectspa.com

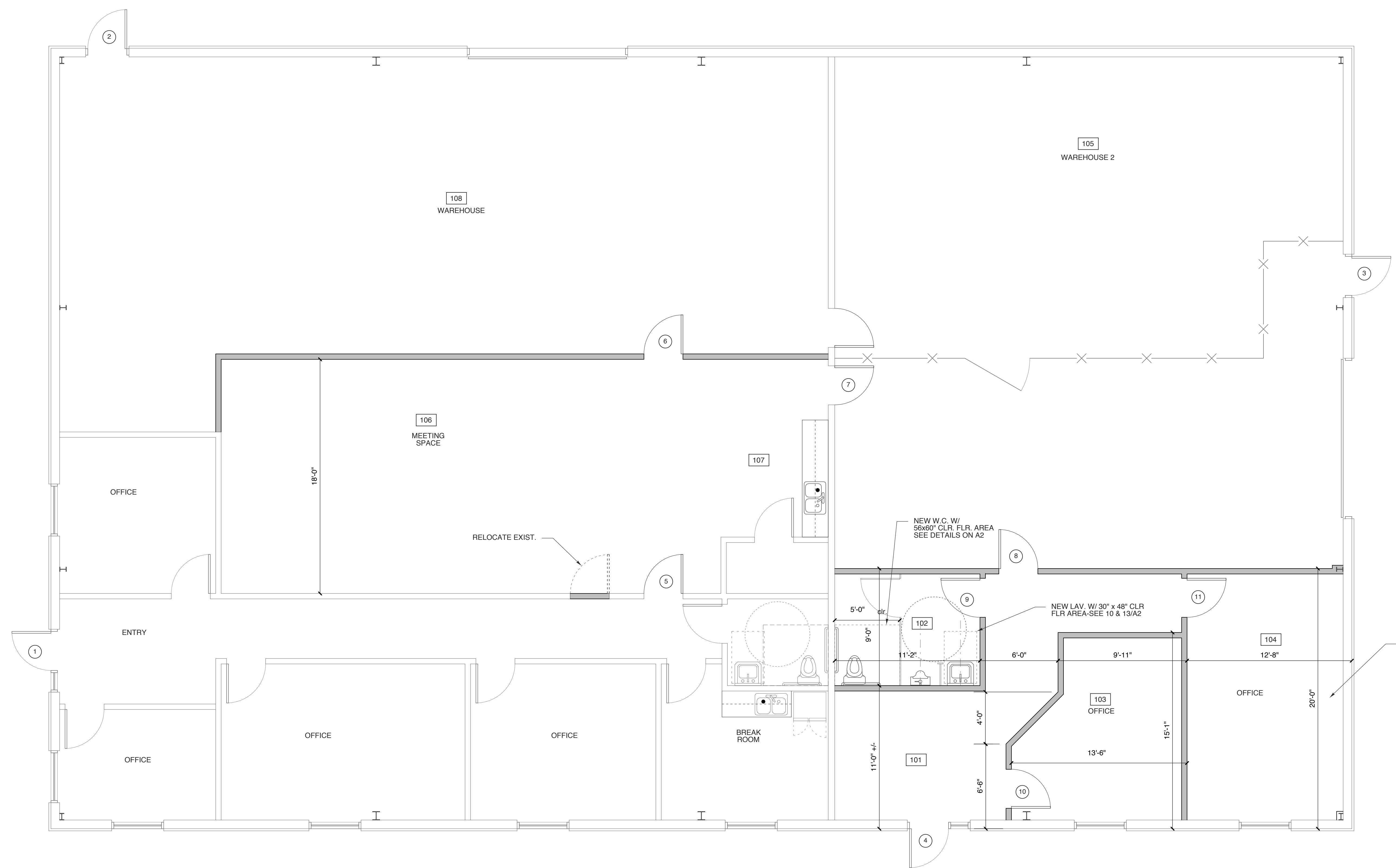
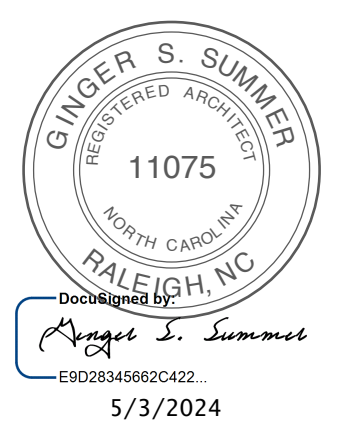

1 FLOOR PLAN
SCALE: 1/4" = 1'-0"

WALL LEGEND	
	EXISTING TO REMAIN
	EXISTING TO BE REMOVED
	NEW FULL HEIGHT PARTITION

PROJECT TITLE
DAWSON'S ELECTRIC
280 JARCO DRIVE
FUQUAY-VARINA, NC

PROJECT NO.
2300f
DRAWING TITLE
FLOOR PLAN

SHEET 3 OF 4

A1.1

PLOT DATE 5/3/24
REVISION ...

This original sheet is 24" x 36", other dimensions indicate it has been altered.
All information on this sheet is the property of W. S. Architects, PA and may not be duplicated in whole or in part without written authorization from W. S. Architects, PA. 2020 ©

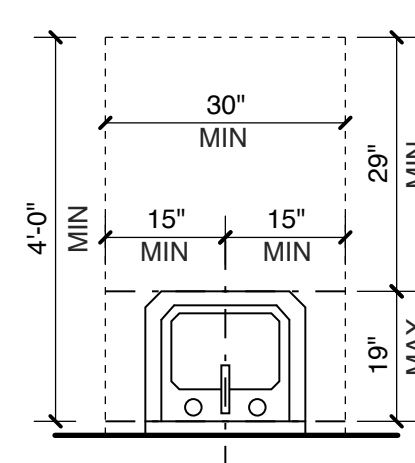

13 HC LAVATORY PLAN
SCALE: 1/2" = 1'-0"

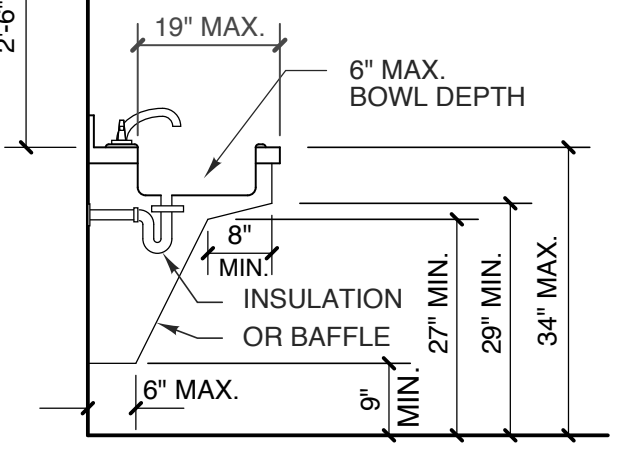

12 ACCESSIBLE SINK
SCALE: 1/2" = 1'-0"

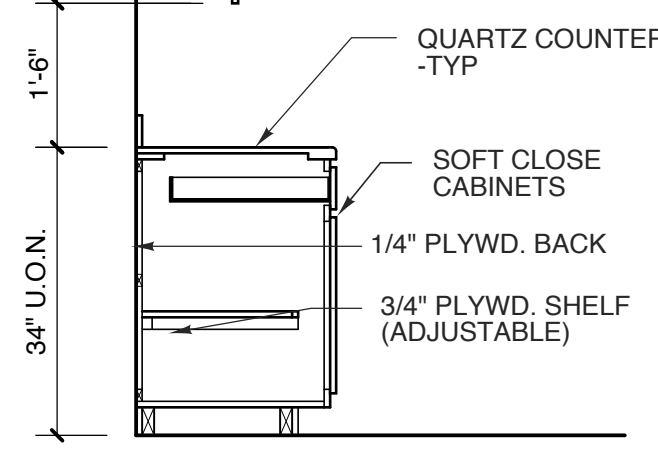

11 TYP. CABINET
SCALE: 1/2" = 1'-0"

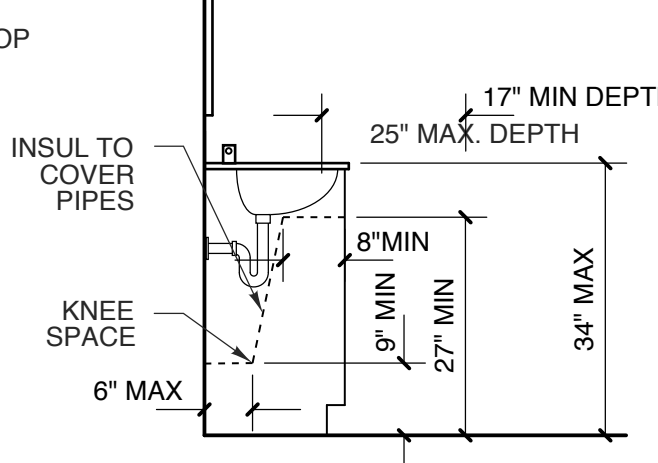

10 HC LAV. SECTION
SCALE: 1/2" = 1'-0"

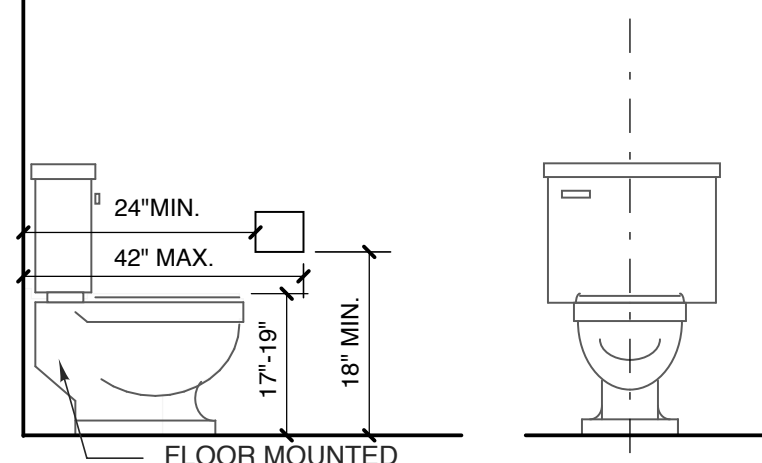

9 TYPICAL HEIGHTS

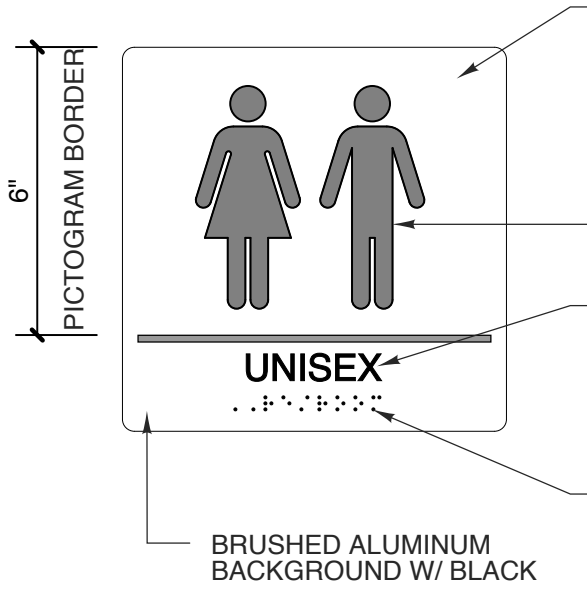
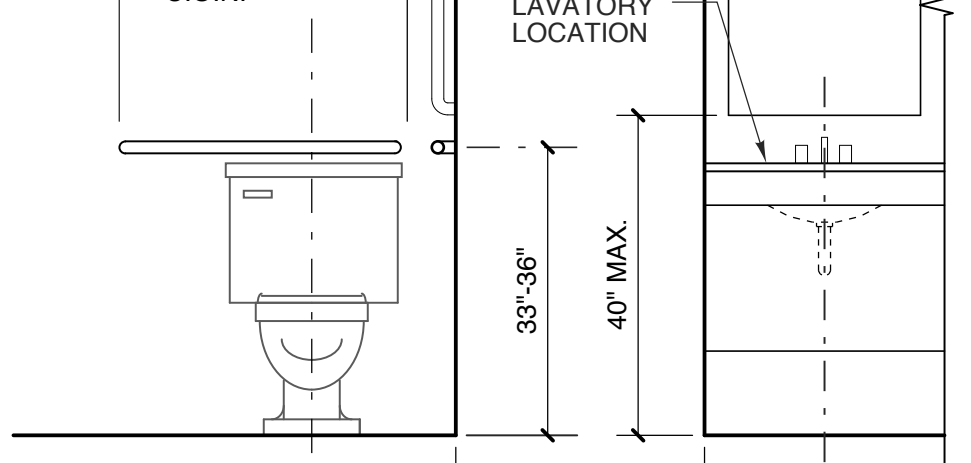
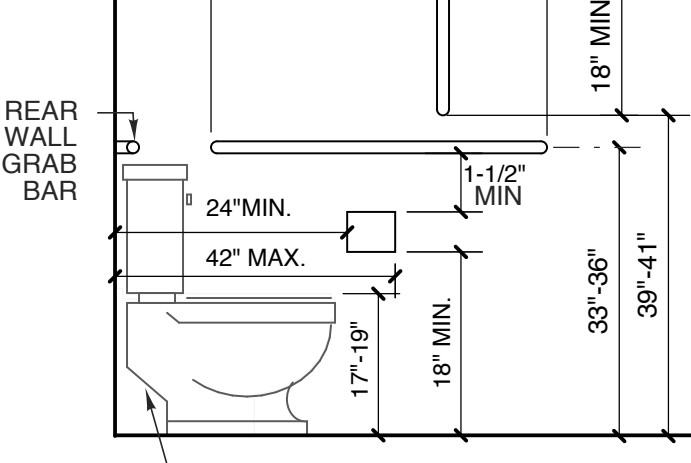

7 TYP. SIGNAGE
SCALE: 3" = 1'-0"

CONTRAST/FINISH CONTRAST TO BE MINIMUM 70% CONTRASTING BETWEEN BACKGROUND AND TEXT. FINISH TO BE MATTE, EGGSHELL, OR NON GLARE

SYMBOL RAISED TACTILE 1/32"

TEXT COPY 5/8" HIGH, UPPERCASE HELVETICA MEDIUM TO BE CENTERED UNDER SYMBOL

BRILLE GRADE 2 BRILLE, JUSTIFIED TO COPY, BELOW VERBIAGE

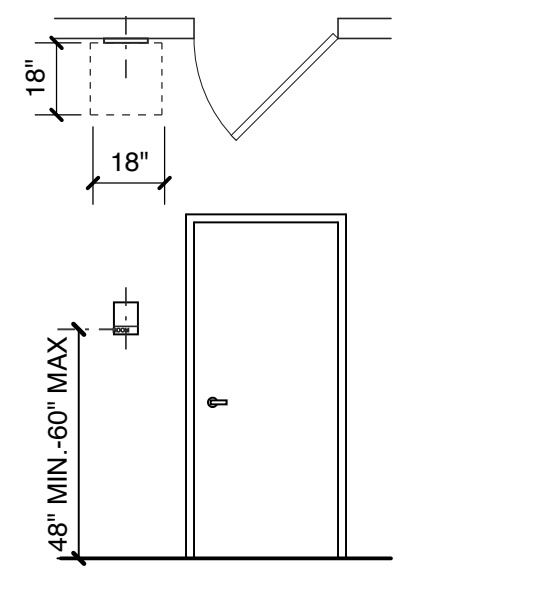

6 SIGNAGE PLACEMENT
SCALE: 1/4" = 1'-0"

NOTES

1. CONTRACTOR TO SUPPLY ALL BLOCKING NEEDED TO SUPPORT REQUIRED RESTROOM ITEMS & MILLWORK UNLESS OTHERWISE NOTED OR STATED PER MANF.
2. VERIFY ALL ROUGH OPENING DIMENSIONS WITH MANUFACTURERS REQUIREMENTS
3. ALL APPLIANCE TO HAVE ANTI-TIP DEVICES INSTALLED. GC TO PROVIDE BLOCKING

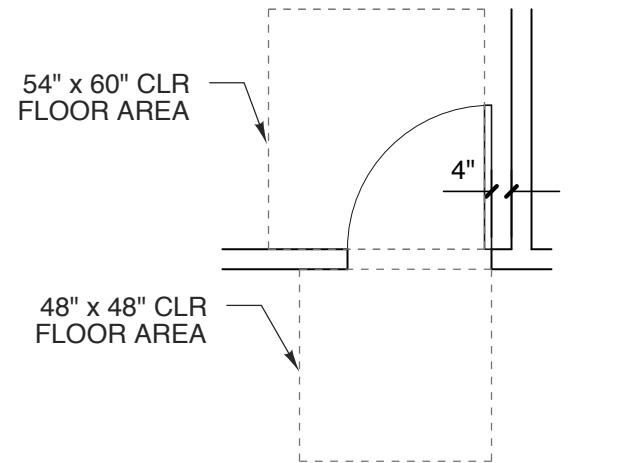

8 TYP. DOOR LOCATION
SCALE: 1/4" = 1'-0"

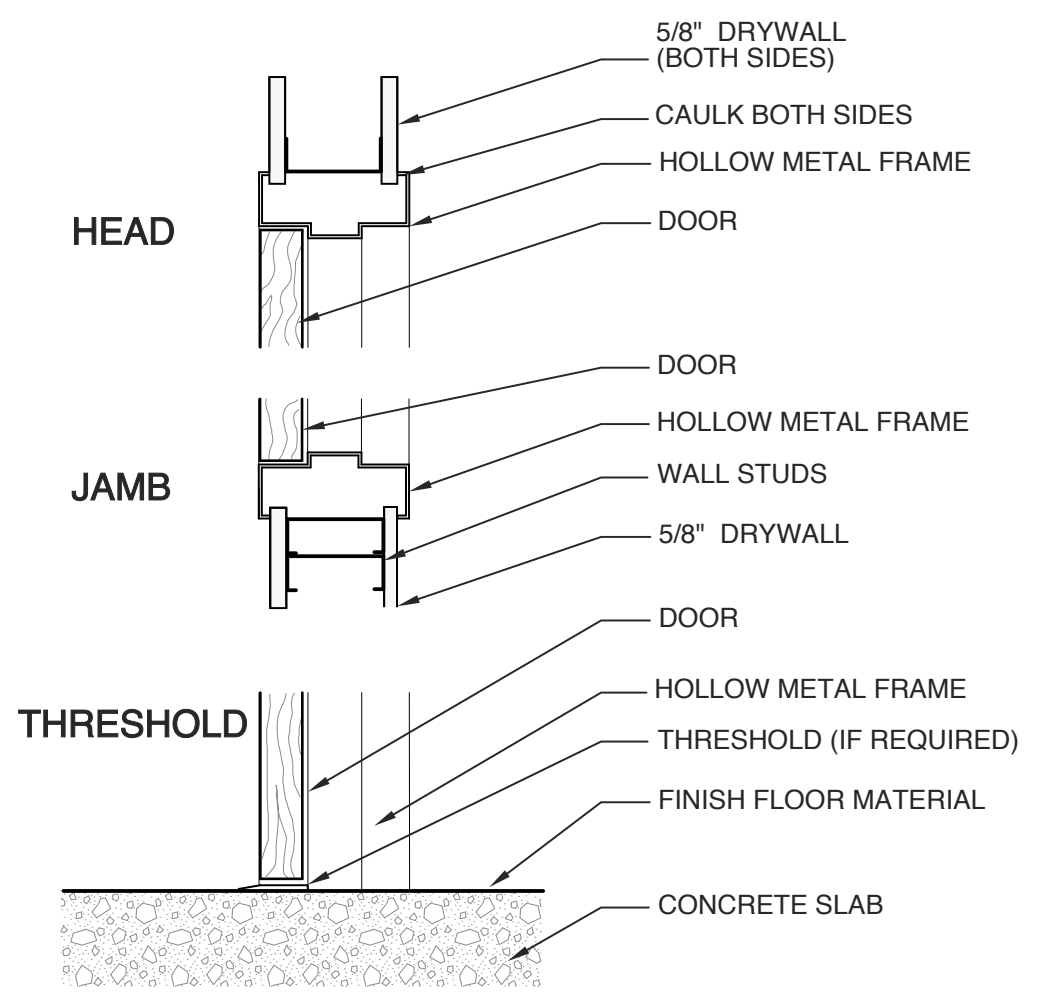

5 INTERIOR SOLID WOOD DOOR
SCALE: 1 1/2" = 1'-0"

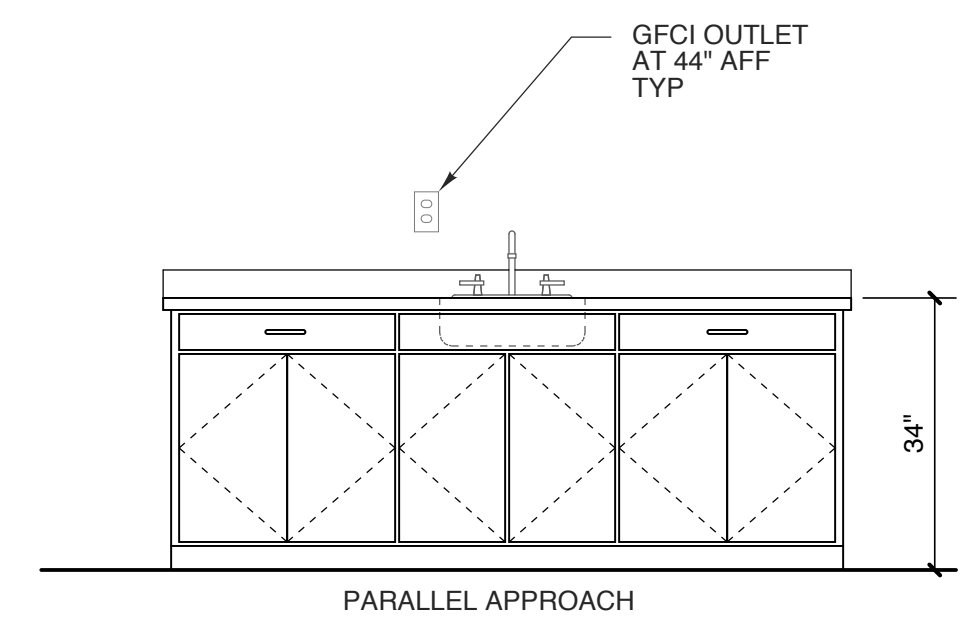

4 TYP. CABINET ELEV
SCALE: 1/2" = 1'-0"

PER ANSI A117.1 SECTION 606.2 EX. 1-A PARALLEL APPROACH COMPLYING WITH SECT. 305 AND CENTERED ON THE SINK, SHALL BE PERMITTED TO A KITCHEN SINK IN A SPACE WHERE A COOK TOP OR CONVENTIONAL RANGE IS NOT PROVIDED.

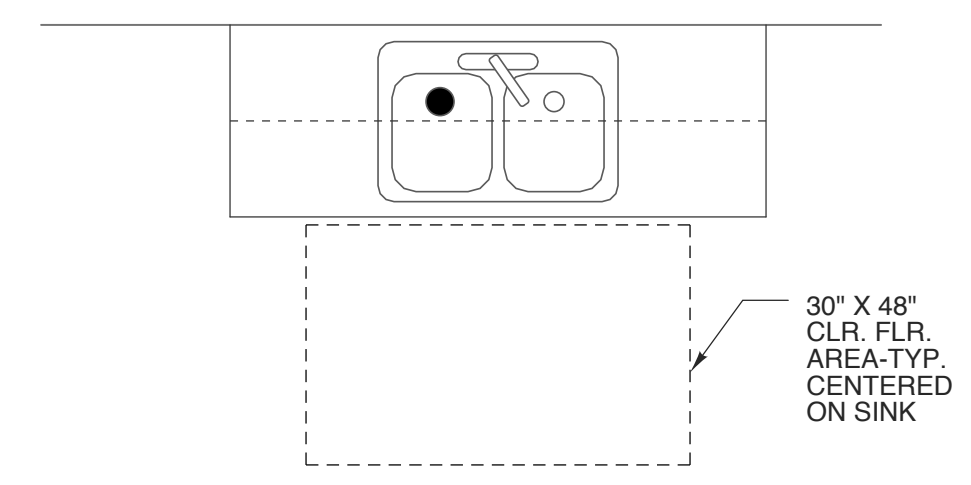

3 PARALLEL APPROACH
SCALE: 1/2" = 1'-0"

Maximum stud heights for interior tenant separation walls			
Size	Gauge	O.C. Spacing	Max. Height
2 1/2"	20 ga.	12"	17'-8"
		16"	16'-5"
		24"	14'-10"
3 5/8"	20 ga.	12"	22'-6"
		16"	20'-8"
		24"	19'-4"
4"	20 ga.	12"	25'-1"
		16"	23'-1"
		24"	20'-9"
		24"	27'-2"
6"	20 ga.	12"	33'-9"
		16"	30'-10"
		24"	27'-2"
		24"	27'-2"
8"	18 ga.	12"	47'-3"
		16"	43'-3"
		24"	38'-5"
		24"	38'-5"

Top track by Fire Trak Corp. or equal and of same gauge as stud

Based upon information furnished by SSMA for CWN type steel studs at deflection of L/120 with a load of 5 psi. Alternate stud types and gauges shall be approved by the architect. This chart shall be applied only to non-bearing wall assemblies for support of their own weight.

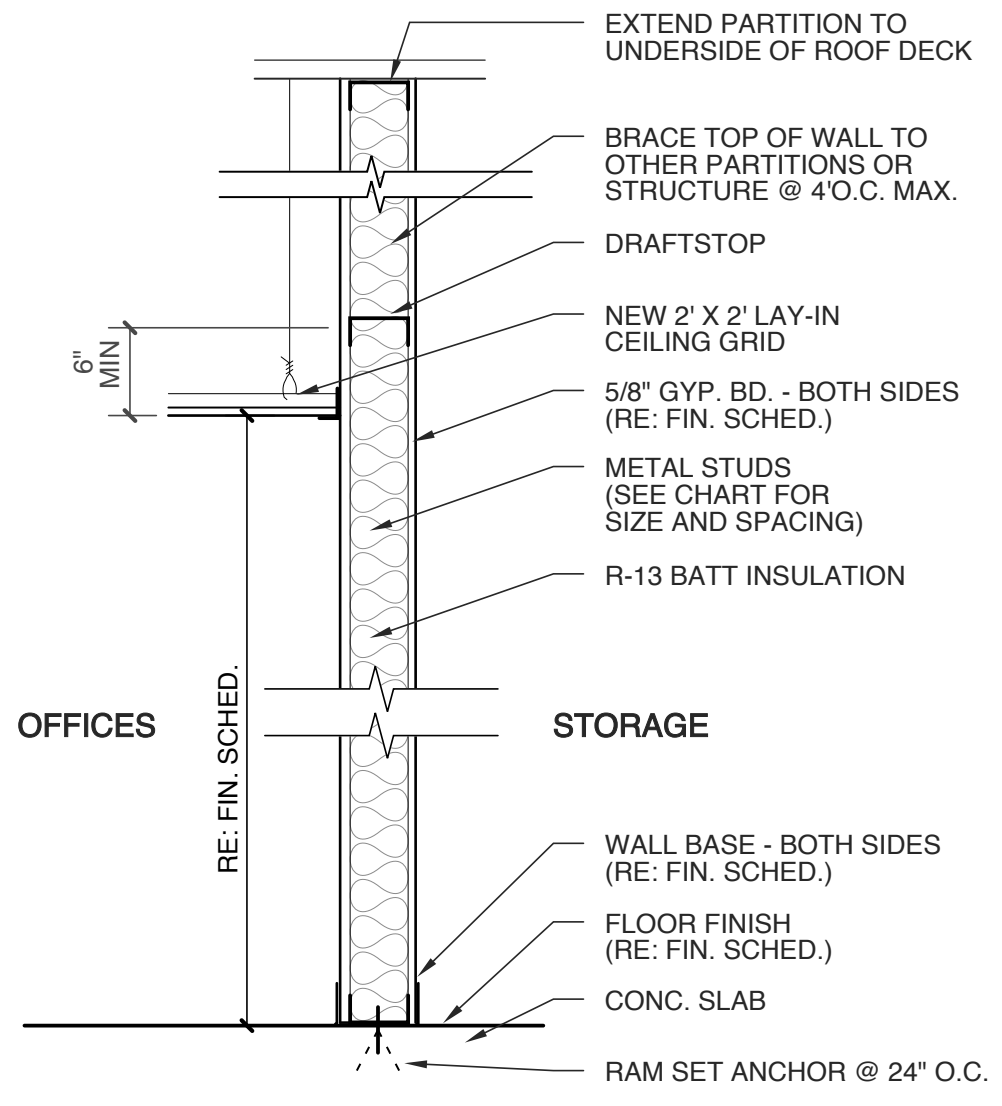

2 INTERIOR WALL SECTION
SCALE: 1" = 1'-0"

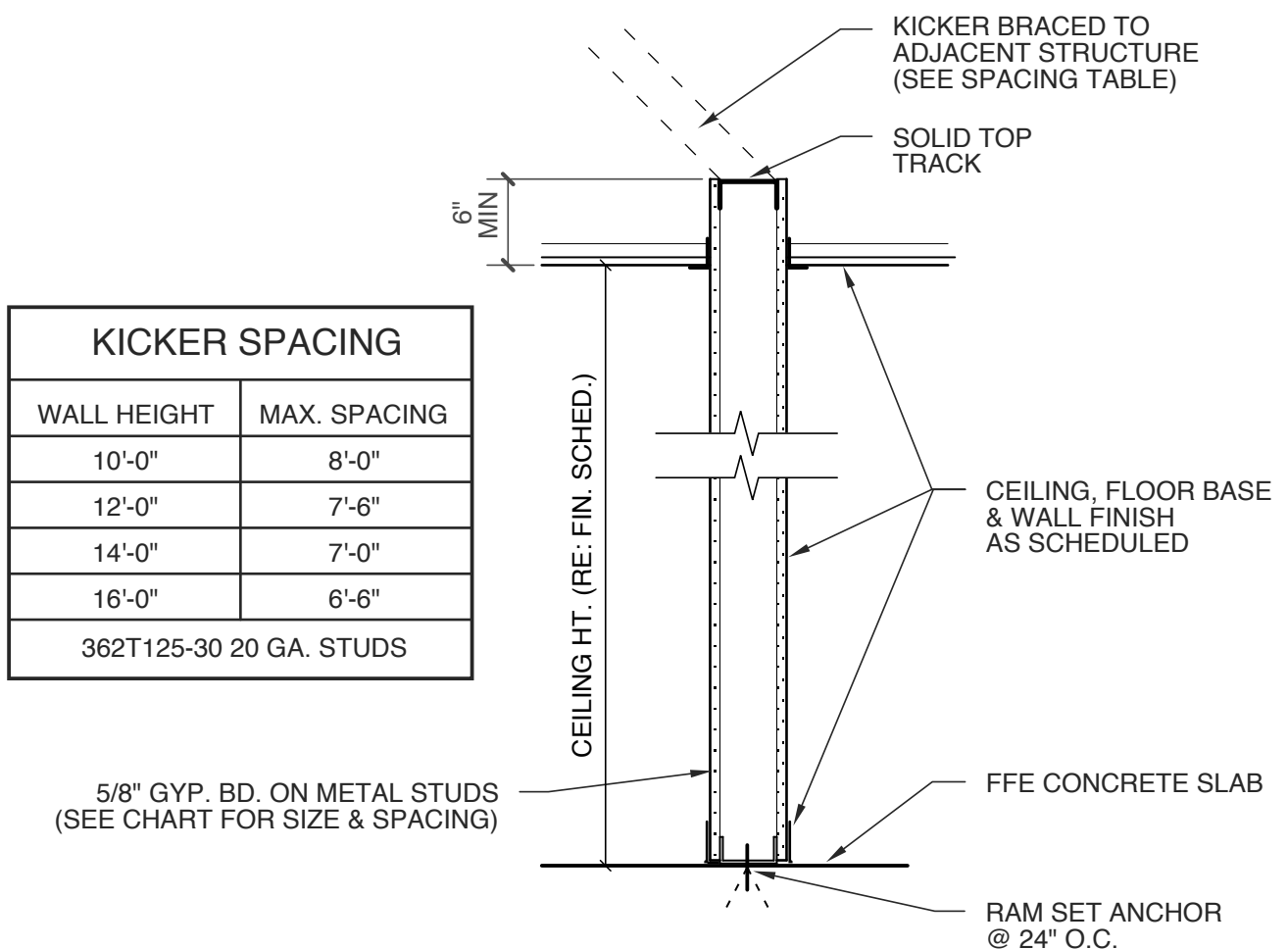

KICKER SPACING	
WALL HEIGHT	MAX. SPACING
10'-0"	8'-0"
12'-0"	7'-6"
14'-0"	7'-0"
16'-0"	6'-6"

1 PARTITION WALL SECTION
SCALE: 1" = 1'-0"

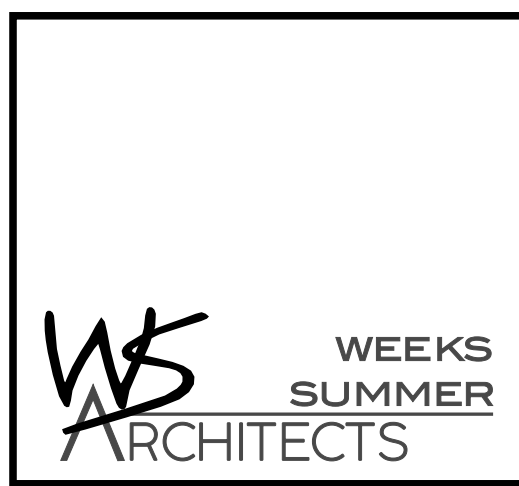

W. S. ARCHITECTS, PA
3305-109 Durham Drive
Raleigh, North Carolina 27603
919.773.9797
www.wsarchitectspa.com

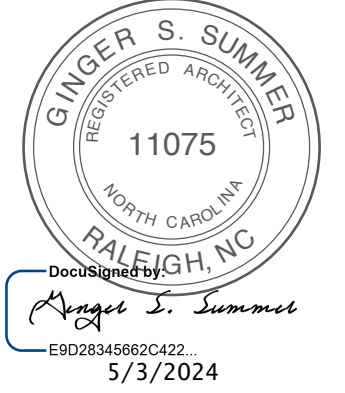

PROJECT TITLE
DAWSON'S ELECTRIC
280 JARCO DRIVE
FUQUAY-VARINA, NC

PROJECT NO.
2300f
DRAWING TITLE
DETAILS

SHEET 4 OF 4

A2

PLOT DATE 5/3/24
REVISION ---

This original sheet is 24" x 36", other dimensions indicate it has been altered.

All information on this sheet is the property of W. S. Architects, PA and may not be duplicated in whole or in part without written authorization from W. S. Architects, PA. 2020 ©