

**ENCLOSED GABLE END BUILDING**

**MAXIMUM 30'-0" WIDE X 16'-0" EAVE HEIGHT WITH BOX FRAME / (UP TO) 145 M.P.H. WIND ZONE - 35 P.S.F. SNOW LOAD**

**FOR:**

NC CARPORTS & GARAGE  
116 EAST MARKET STREET  
ELKIN, NORTH CAROLINA  
TELE: 336-368-0668

ISSUE DATE: 01.23.24

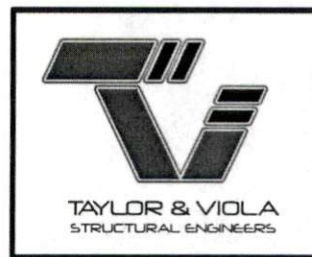

Town of Coats

NOTE: THESE DRAWINGS ARE VALID FOR (1) CALENDAR YEAR AFTER THE ISSUE DATE LISTED ON THIS SHEET.

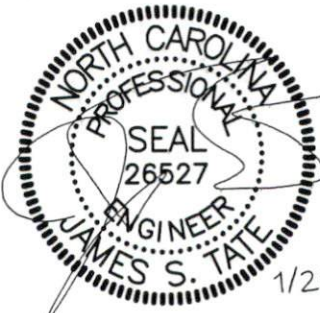

1/23/24

DOCUMENTS DESIGNED AND DRAWN TO MEET THE 2018 NC BUILDING CODE (2015 IBC)



1/23/24

DOCUMENTS DESIGNED AND DRAWN TO MEET THE 2021 SC BUILDING CODE (2021 IBC)



1/23/24

DOCUMENTS DESIGNED AND DRAWN TO MEET THE 2018 VA CONSTRUCTION CODE (2018 IBC)



1/23/24

DOCUMENTS DESIGNED AND DRAWN TO MEET THE 2012 IBC

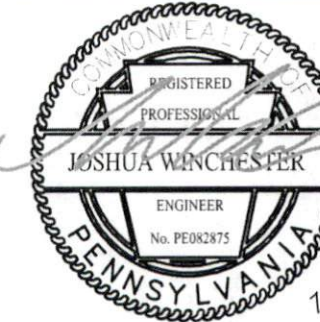

1/23/24

DOCUMENTS DESIGNED AND DRAWN TO MEET THE 2018 IBC



1/23/24

DOCUMENTS DESIGNED AND DRAWN TO MEET THE 2020 BUILDING CODE OF NEW YORK STATE (2018 IBC)



1/23/24

DOCUMENTS DESIGNED AND DRAWN TO MEET THE 20210 BUILDING CODENEW JERSEY EDITION (2021 IBC)



1/23/24

DOCUMENTS DESIGNED AND DRAWN TO MEET THE 2018 IBC

**Taylor & Viola**  
 STRUCTURAL ENGINEERS  
 P.O.B. 2616 HICKORY NORTH CAROLINA  
 TEL: 828-328-6331 FAX: 828-322-1901  
 WWW.TAYLORVIOLA.COM

JCMT Associates, PLLC  
 211 Stone Drive, Pilot Mountain, NC 27041  
 Telephone: (336) 399-6277

NC CARPORTS  
 & GARAGES

116 EAST MARKET STREET  
 ELKIN, NORTH CAROLINA 28621  
 TELE: 336-368-0668

DRAWN BY:  
 BKS

PROJECT NO:  
 MISC

DATE:  
 01.23.24

SHEET NO:  
**81**

NOTE: THESE DRAWINGS ARE VALID FOR (1) CALENDAR YEAR AFTER THE ISSUE DATE LISTED ON THIS SHEET.

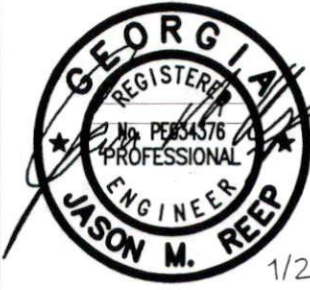

1/23/24

DOCUMENTS DESIGNED AND DRAWN TO MEET THE 2018 IBC

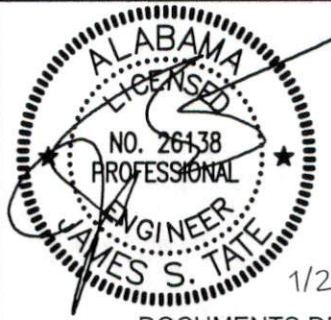

1/23/24

DOCUMENTS DESIGNED AND DRAWN TO MEET THE 2021 BUILDING CODE OF ALABAMA (2021 IBC)



1/23/24

DOCUMENTS DESIGNED AND DRAWN TO MEET THE 2018 IBC



1/23/24

DOCUMENTS DESIGNED AND DRAWN TO MEET THE NINTH EDITION OF THE MA STATE BUILDING CODE

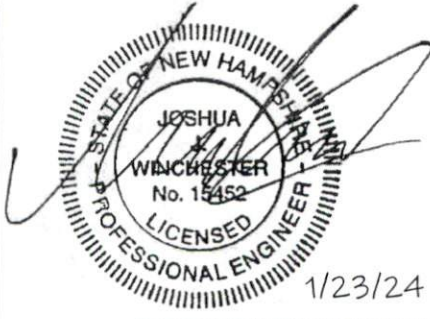

1/23/24

DOCUMENTS DESIGNED AND DRAWN TO MEET THE 2018 IBC



1/23/24

DOCUMENTS DESIGNED AND DRAWN TO MEET THE 2017 IBC



1/23/24

DOCUMENTS DESIGNED AND DRAWN TO MEET THE 2018 KENTUCKY BUILDING CODE (2015 IBC)



TAYLOR & VIOLA  
STRUCTURAL ENGINEERS  
P.O.B. 2616 HICKORY NORTH CAROLINA  
TELE: 828-328-6331 FAX: 828-322-1801  
WWW.TAYLORVIOLA.COM

JCMT Associates, PLLC  
211 Stone Drive, Pilot Mountain, NC 27041  
Telephone: (336) 399-6277

NC CARPORTS  
& GARAGES

116 EAST MARKET STREET  
ELKIN, NORTH CAROLINA 28621  
TELE: 336-368-0668

DRAWN BY:  
BKS

PROJECT NO:  
MISC

DATE:  
01.23.24

SHEET NO:  
S1

NOTE: THESE DRAWINGS ARE VALID FOR (1) CALENDAR YEAR AFTER THE ISSUE DATE LISTED ON THIS SHEET.

# SHEET INDEX

SHEET NUMBER	SHEET TITLE
S0	SEALED COVER SHEET
S1	P.E. SEALS SHEET
S1A	P.E. SEALS SHEET
S2	DRAWING INDEX
S3	GENERAL NOTES AND SPECIFICATIONS
S4	SIDE AND END ELEVATIONS
S5	TYPICAL RAFTER / COLUMN FRAME SECTIONS
S5A	TYPICAL RAFTER / COLUMN FRAME SECTIONS
S5B	TYPICAL RAFTER / COLUMN FRAME AND SIDE FRAMING SECTION
S6	COLUMN CONNECTION DETAILS (LACED COLUMN)
S6A	COLUMN CONNECTION DETAILS (DOUBLE AND SINGLE COLUMN)
S6B	COLUMN CONNECTION DETAILS (LACED COLUMN)
S6C	COLUMN CONNECTION DETAILS (DOUBLE AND SINGLE COLUMN)
S7	BASE RAIL ANCHORAGE
S7A	BASE RAIL ANCHORAGE
S7B	BASE RAIL ANCHORAGE
S7C	BASE RAIL ANCHORAGE
S7D	BASE RAIL ANCHORAGE
S7E	BASE RAIL ANCHORAGE
S7F	BASE RAIL ANCHORAGE
S7G	BASE RAIL ANCHORAGE
S8	BASE RAIL ANCHORAGE
S8A	BASE RAIL ANCHORAGE
S9	TYPICAL END WALL OPENINGS FRAMING SECTIONS
S9A	TYPICAL SIDE WALL OPENINGS FRAMING SECTIONS
S10	CONNECTION DETAILS
S11	CONNECTION DETAILS
S12	CONNECTION DETAILS
S13	CONNECTION DETAILS
S14	CONNECTION DETAILS
S15	LEAN-TO OPTIONS
S15A	LEAN-TO CONNECTION DETAILS
S15B	LEAN-TO CONNECTION DETAILS
S15C	LEAN-TO CONNECTION DETAILS
S16	VERTICAL ROOF / SIDING OPTION END AND SIDE ELEVATION
S16A	VERTICAL ROOF / SIDING OPTION END SECTION
S16B	VERTICAL ROOF / SIDING OPTION SIDE SECTION
S17	SIDE WALL HEADER OPTIONS
S17A	END WALL HEADER OPTIONS

**TAYLOR & VIOLA**  
 STRUCTURAL ENGINEERS  
P.O.B. 2616 HICKORY NORTH CAROLINA  
 TELE: 828-338-6931 FAX: 828-322-1901  
 WWW: TAYLORVIOLA.COM  
**JCMT Associates, PLLC**  
211 Stone Drive, Pilot Mountain, NC 27041  
 Telephone: (336) 399-6277

**NC CARPORTS  
& GARAGES**  
116 EAST MARKET STREET  
 ELKIN, NORTH CAROLINA 28621  
 TELE: 336-368-0668

**DRAWN BY:**  
 BKS

**PROJECT NO:**  
 MISC

**DATE:**  
 01.23.24

**SHEET NO:**  
**S2**

NOTE: THESE DRAWINGS ARE VALID FOR (1) CALENDAR YEAR AFTER THE ISSUE DATE LISTED ON THIS SHEET.



BOX EVE FRAME RAFTER STRUCTURE

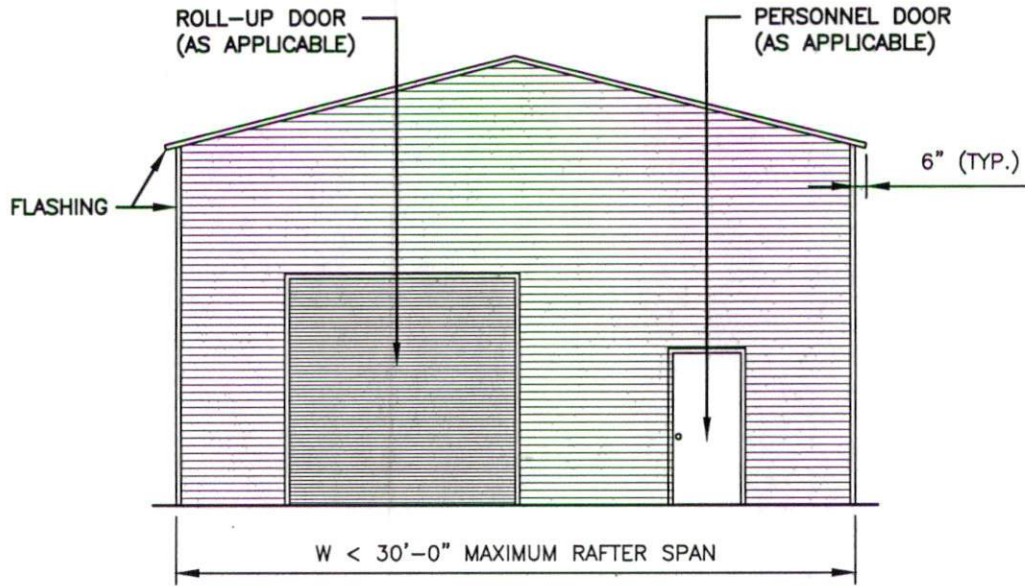

TYPICAL END ELEVATION

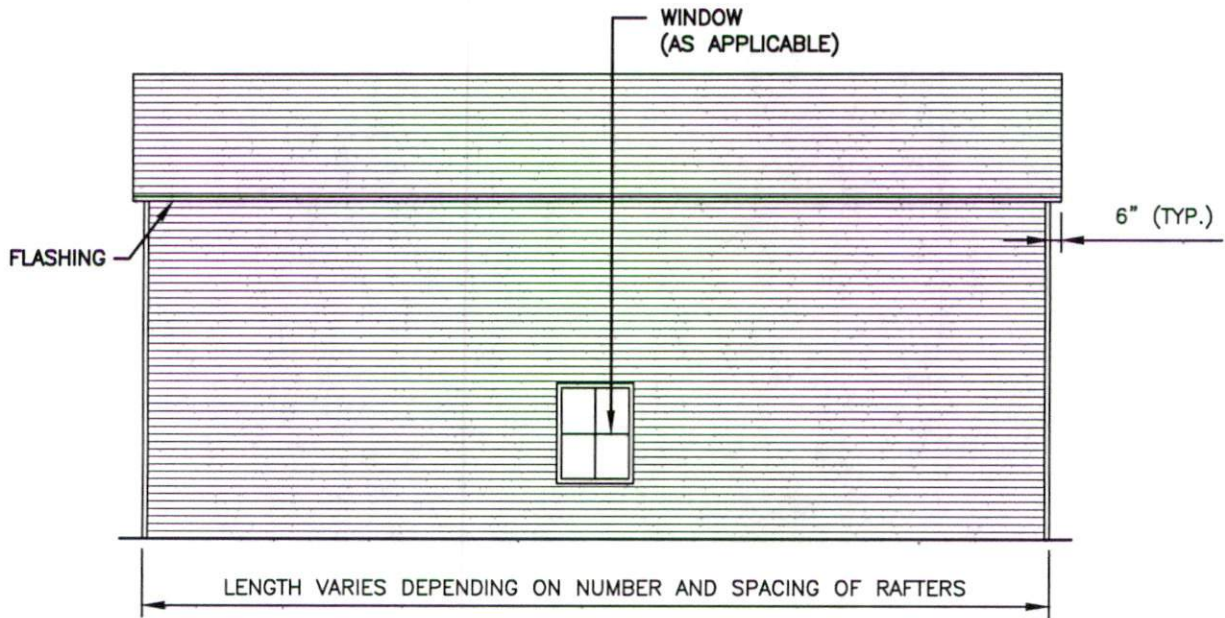

TYPICAL SIDE ELEVATION

**TAYLOR & VIOLA**  
 STRUCTURAL ENGINEERS  
 P.O.B. 2516 HICKORY NORTH CAROLINA  
 TELE: 828-388-6331 FAX: 828-322-1881  
 WWW.TAYLORVIOLA.COM  
**JCMT Associates, PLLC**  
 211 Stone Drive, Pilot Mountain, NC 27041  
 Telephone: (336) 399-6277

**NC CARPORTS  
& GARAGES**  
 116 EAST MARKET STREET  
 ELKIN, NORTH CAROLINA 28621  
 TELE: 336-368-0668

DRAWN BY:  
 BKS

PROJECT NO:  
 MISC

DATE:  
 01.23.24

SHEET NO:  
**S4**

NOTE: THESE DRAWINGS ARE VALID FOR (1) CALENDAR YEAR AFTER THE ISSUE DATE LISTED ON THIS SHEET.

'U' BRACE TRUSS TIE - NOTE:  
 6'-0" BRACE FOR 21'-24' BUILDING WIDTH  
 20' TUBE TRUSS TIE (AS SHOWN) FOR 25'-30'

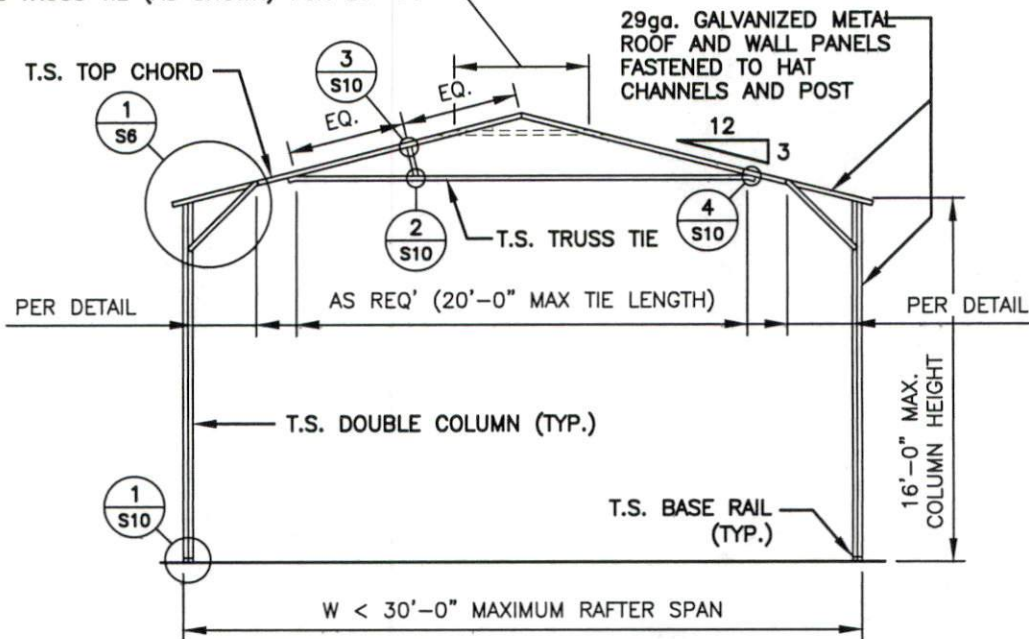

TYPICAL RAFTER / COLUMN FRAME SECTION

'U' BRACE TRUSS TIE - NOTE:  
 6'-0" BRACE FOR 21'-24' BUILDING WIDTH  
 20' TUBE TRUSS TIE (AS SHOWN) FOR 25'-30'

NOTE:  
 H.S.S. 2-1/2"x2-1/2"x14ga. OR 2-1/4"x2-1/4"x14ga.  
 MATERIAL MAY BE USED FOR TRUSS METAL.

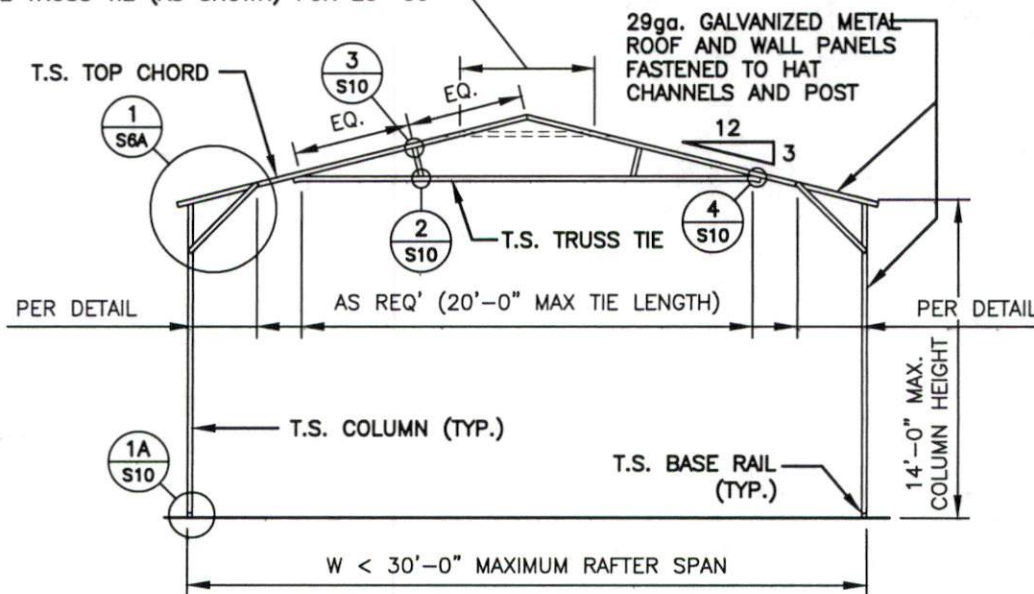

TYPICAL RAFTER / COLUMN FRAME SECTION

**TAYLOR & VIOLA**  
 STRUCTURAL ENGINEERS  
 P.O.B. 2616 HICKORY NORTH CAROLINA  
 TELE: 828-388-6331 FAX: 828-322-1901  
 WWW.TAYLORVIOLA.COM  
**JCMT Associates, PLLC**  
 211 Stone Drive, Pilot Mountain, NC 27041  
 Telephone: (336) 399-6277

**NC CARPORTS & GARAGES**  
 116 EAST MARKET STREET  
 ELKIN, NORTH CAROLINA 28621  
 TELE: 336-368-0668

DRAWN BY:  
 BKS

PROJECT NO:  
 MISC

DATE:  
 01.23.24

SHEET NO:  
**S5**

NOTE: THESE DRAWINGS ARE VALID FOR (1) CALENDAR YEAR AFTER THE ISSUE DATE LISTED ON THIS SHEET.

'U' BRACE TRUSS TIE - NOTE:  
 6'-0" BRACE FOR 21'-24' BUILDING WIDTH  
 20' TUBE TRUSS TIE (AS SHOWN) FOR 25'-30'

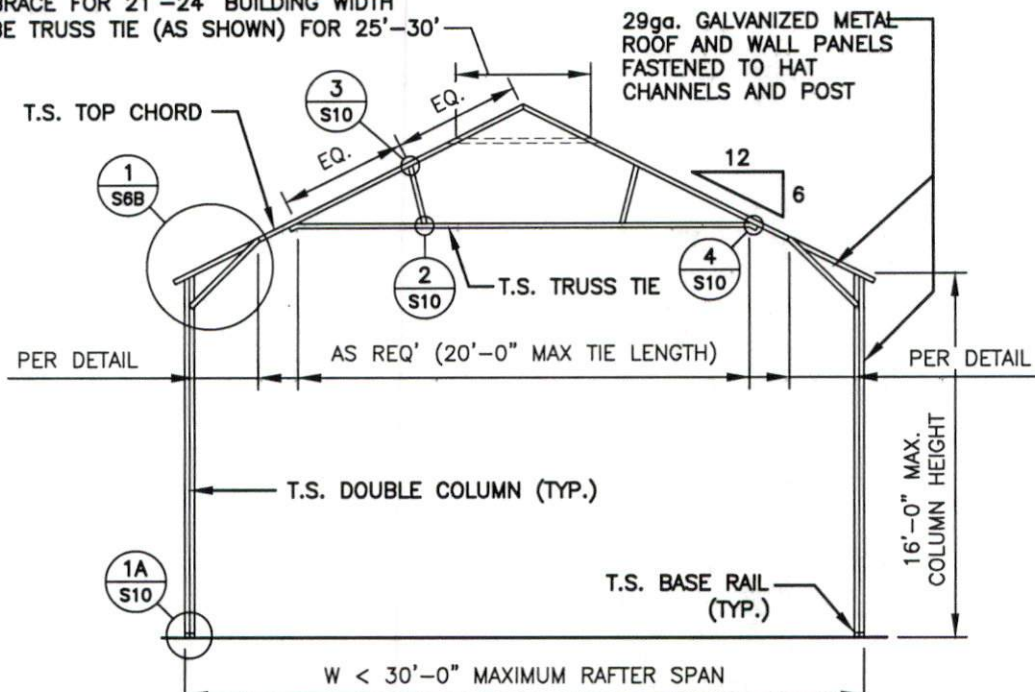

**TYPICAL RAFTER / COLUMN FRAME SECTION**

'U' BRACE TRUSS TIE - NOTE:  
 6'-0" BRACE FOR 21'-24' BUILDING WIDTH  
 20' TUBE TRUSS TIE (AS SHOWN) FOR 25'-30'

NOTE:  
 H.S.S. 2-1/2"x2-1/2"x14ga. OR 2-1/4"x2-1/4"x14ga.  
 MATERIAL MAY BE USED FOR TRUSS METAL.

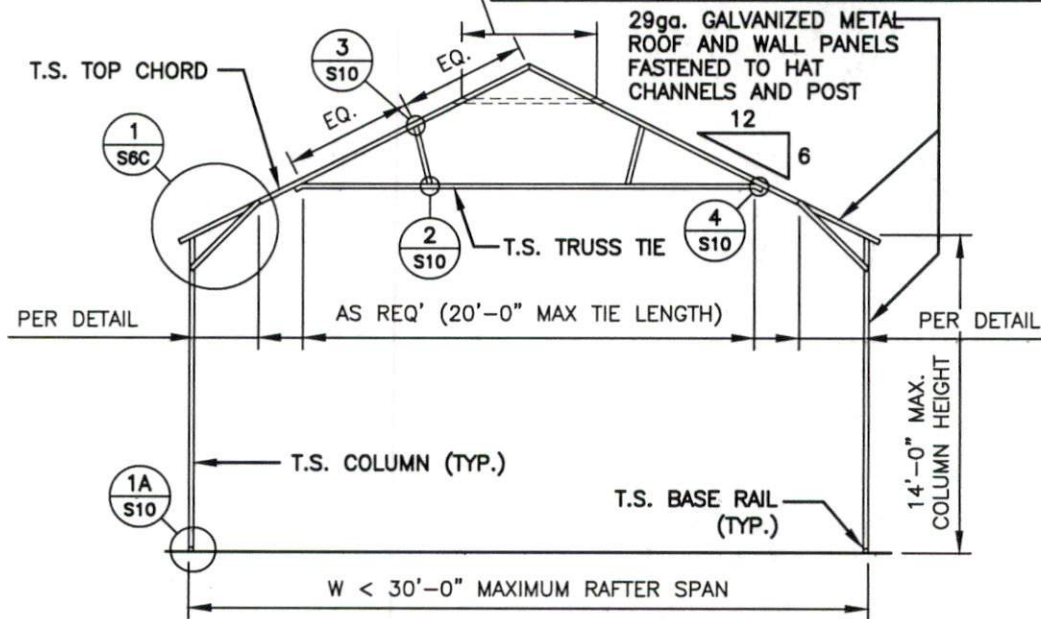

**TYPICAL RAFTER / COLUMN FRAME SECTION**

**TAYLOR & VIOLA**  
 STRUCTURAL ENGINEERS  
 P.O.B. 2616 HICKORY NORTH CAROLINA  
 TELE: 828-328-6331 FAX: 828-322-1801  
 WWW.TAYLORVIOLA.COM  
**JCMT Associates, PLLC**  
 211 Stone Drive, Pilot Mountain, NC 27041  
 Telephone: (336) 399-6277

**NC CARPORTS & GARAGES**  
 116 EAST MARKET STREET  
 ELKIN, NORTH CAROLINA 28621  
 TELE: 336-368-0668

DRAWN BY:  
 BKS

PROJECT NO:  
 MISC

DATE:  
 01.23.24

SHEET NO:  
**S5A**

NOTE: THESE DRAWINGS ARE VALID FOR (1) CALENDAR YEAR AFTER THE ISSUE DATE LISTED ON THIS SHEET.



**NOTE:**  
 H.S.S. 2-1/2"x2-1/2"x14ga. OR  
 2-1/4"x2-1/4"x14ga. MATERIAL  
 MAY BE USED FOR TRUSS METAL

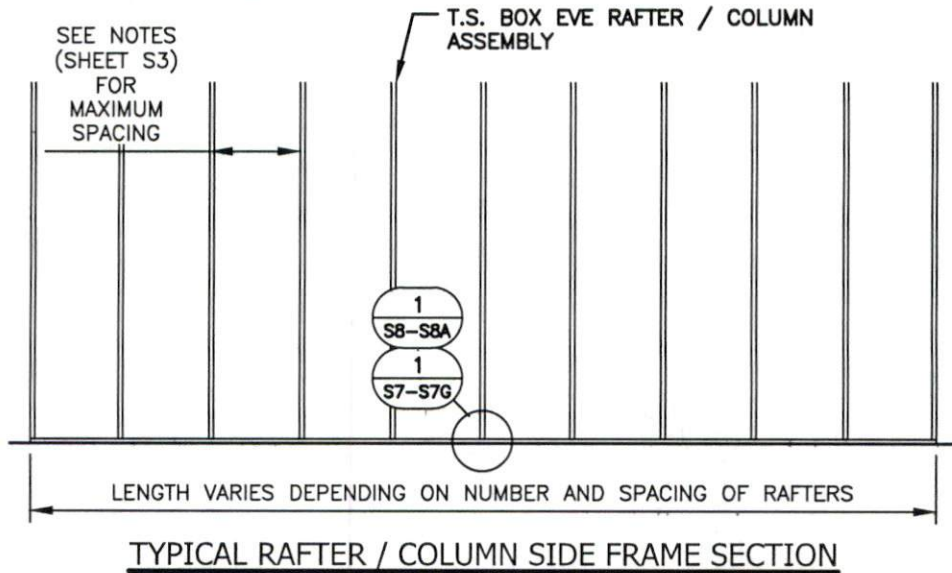

**Taylor & Viola**  
 STRUCTURAL ENGINEERS  
 P.O.B. 2616 HICKORY NORTH CAROLINA  
 TELE: 828-328-6331 FAX: 828-322-1801  
 WWW.TAYLORVIOLA.COM

**JCMT Associates, PLLC**  
 211 Stone Drive, Pilot Mountain, NC 27041  
 Telephone: (336) 399-6277

**NC CARPORTS  
 & GARAGES**  
 116 EAST MARKET STREET  
 ELKIN, NORTH CAROLINA 28621  
 TELE: 336-368-0668

**DRAWN BY:**  
 BKS

**PROJECT NO:**  
 MISC

**DATE:**  
 01.23.24

**SHEET NO:**  
**S58**

**NOTE: THESE DRAWINGS ARE VALID FOR (1) CALENDAR YEAR AFTER THE ISSUE DATE LISTED ON THIS SHEET.**

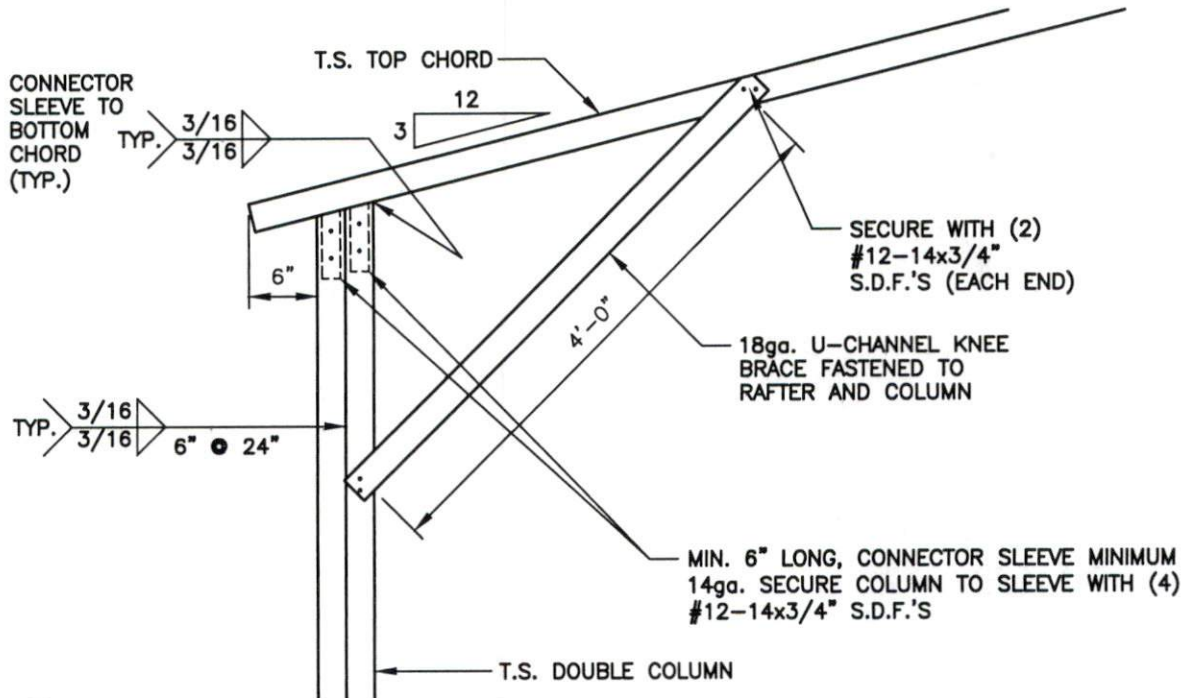

1 BOX EAVE / CORNER POST CONNECTION DETAIL FOR HEIGHT.S. 14'-1" < TO  
 S6 SCALE: 1/8" = 1'-0"

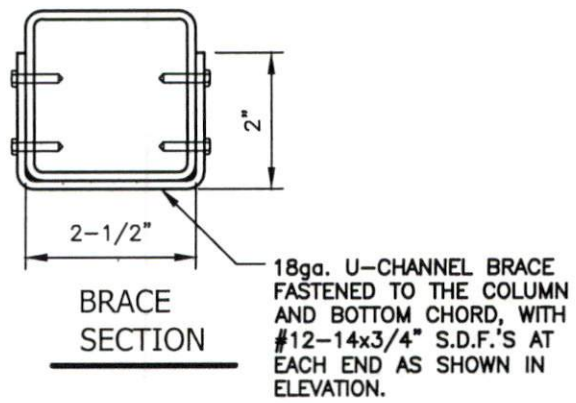

**Taylor & Viola**  
 STRUCTURAL ENGINEERS  
 P.O.B. 2616 HICKORY NORTH CAROLINA  
 TELE: 828-328-6331 FAX: 828-322-1901  
 WWW.TAYLORVIOLA.COM  
**JCMT Associates, PLLC**  
 211 Stone Drive, Pilot Mountain, NC 27041  
 Telephone: (336) 399-6277

**NC CARPORTS & GARAGES**  
 116 EAST MARKET STREET  
 ELKIN, NORTH CAROLINA 28621  
 TELE: 336-368-0668

**DRAWN BY:**  
 BKS  
**DATE:**  
 01.23.24

**PROJECT NO:**  
 MISC  
**SHEET NO:**  
**S6**

NOTE: THESE DRAWINGS ARE VALID FOR (1) CALENDAR YEAR AFTER THE ISSUE DATE LISTED ON THIS SHEET.

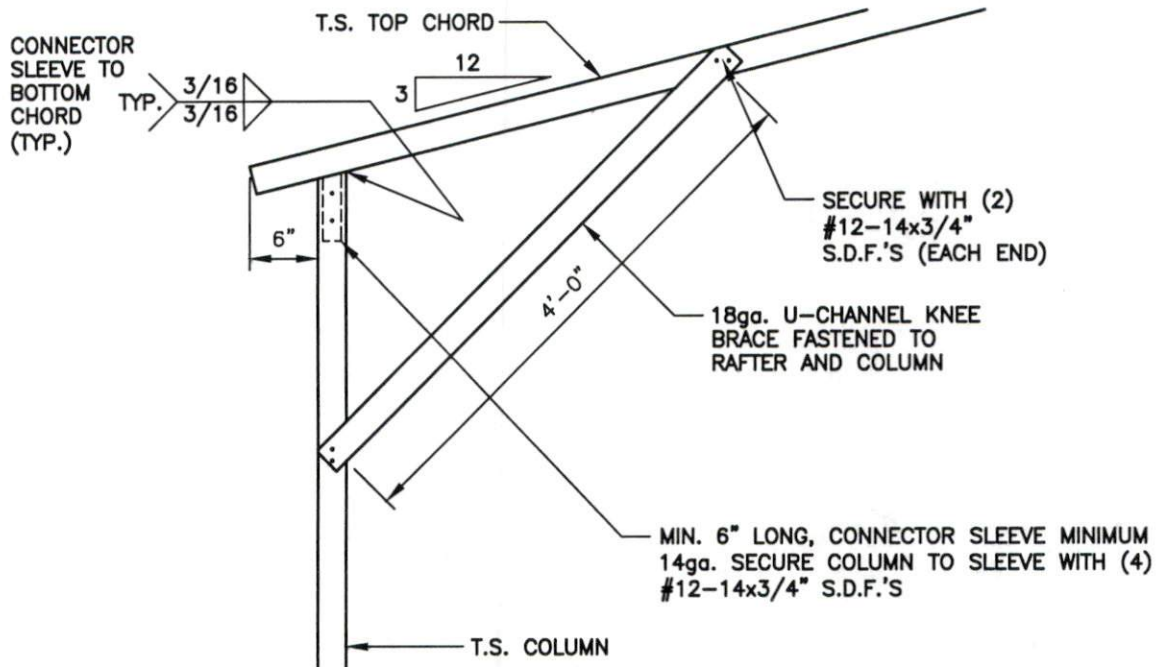

1 BOX EAVE / CORNER POST CONNECTION DETAIL FOR HEIGHT.S. < 14'-0"

S6A SCALE: 3/4" = 1'-0"

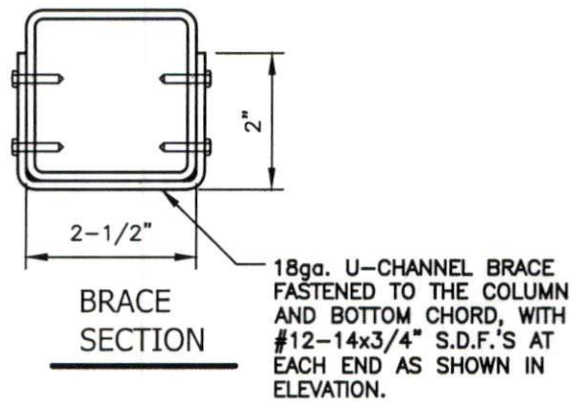

**TAYLOR & VIOLA**  
 STRUCTURAL ENGINEERS  
 P.O.B. 2516 HICKORY NORTH CAROLINA  
 TELE: 828-338-4331 FAX: 828-322-1891  
 WWW.TAYLORVIOLA.COM

JCMT Associates, PLLC  
 211 Stone Drive, Pilot Mountain, NC 27041  
 Telephone: (336) 399-6277

NC CARPORTS  
 & GARAGES

116 EAST MARKET STREET  
 ELKIN, NORTH CAROLINA 28621  
 TELE: 336-368-0668

DRAWN BY:  
BKS

PROJECT NO:  
MISC

DATE:  
01.23.24

SHEET NO:  
S6A

NOTE: THESE DRAWINGS ARE VALID FOR (1) CALENDAR YEAR AFTER THE ISSUE DATE LISTED ON THIS SHEET.

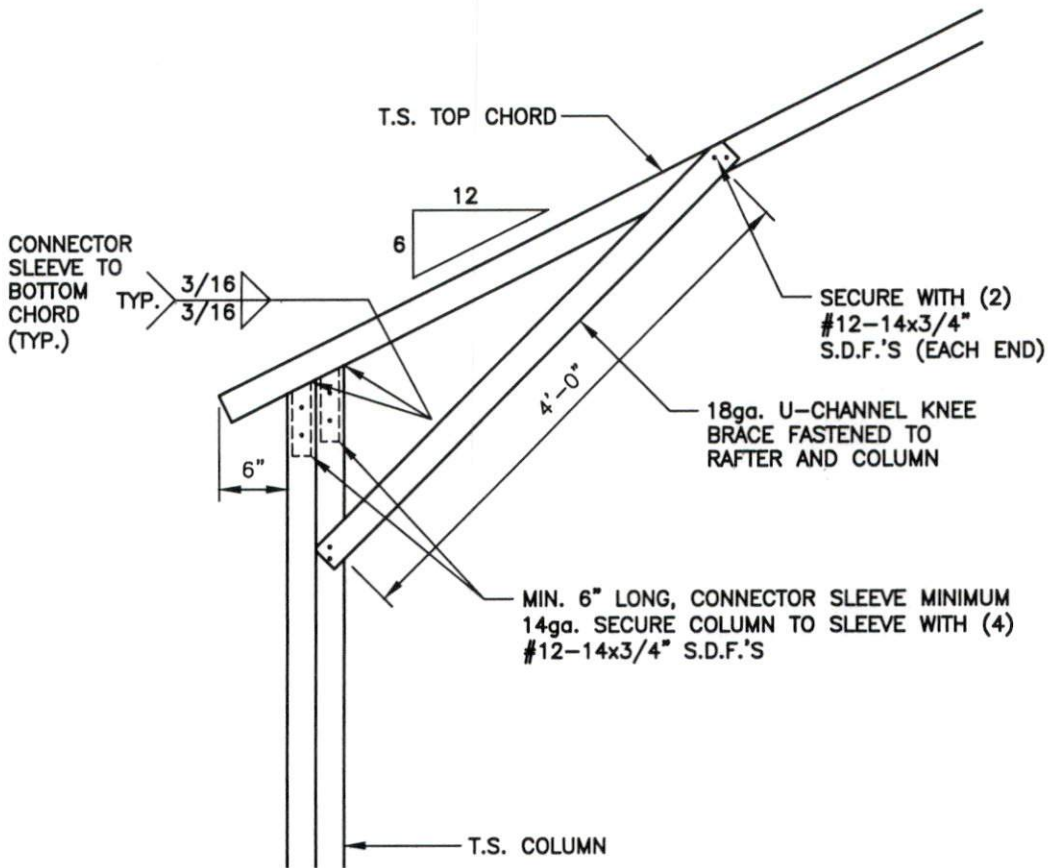

1 BOX EAVE / CORNER POST CONNECTION DETAIL FOR HEIGHT.S. 14'-1" < TO  
 S6C SCALE: 1/16" = 1'-0"

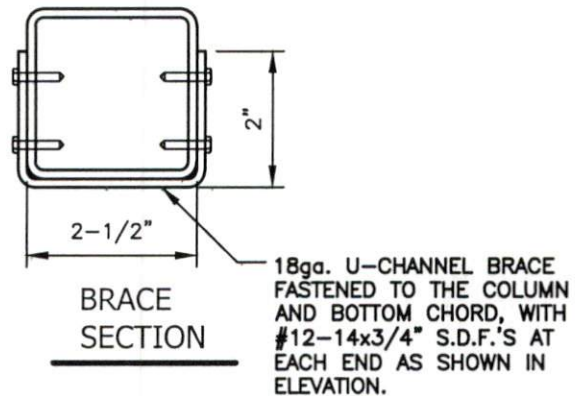

**TAYLOR & VIOLA**  
 STRUCTURAL ENGINEERS  
 P.O.B. 2616 HICKORY NORTH CAROLINA  
 TELE: 828-328-4331 FAX: 828-322-1801  
 WWW.TAYLORVIOLA.COM

JCMT Associates, PLLC  
 211 Stone Drive, Pilot Mountain, NC 27041  
 Telephone: (336) 399-6277

NC CARPORTS  
 & GARAGES  
 116 EAST MARKET STREET  
 ELKIN, NORTH CAROLINA 28621  
 TELE: 336-368-0668

DRAWN BY:  
BKS

PROJECT NO:  
MISC

DATE:  
01.23.24

SHEET NO:  
S8B

NOTE: THESE DRAWINGS ARE VALID FOR (1) CALENDAR YEAR AFTER THE ISSUE DATE LISTED ON THIS SHEET.

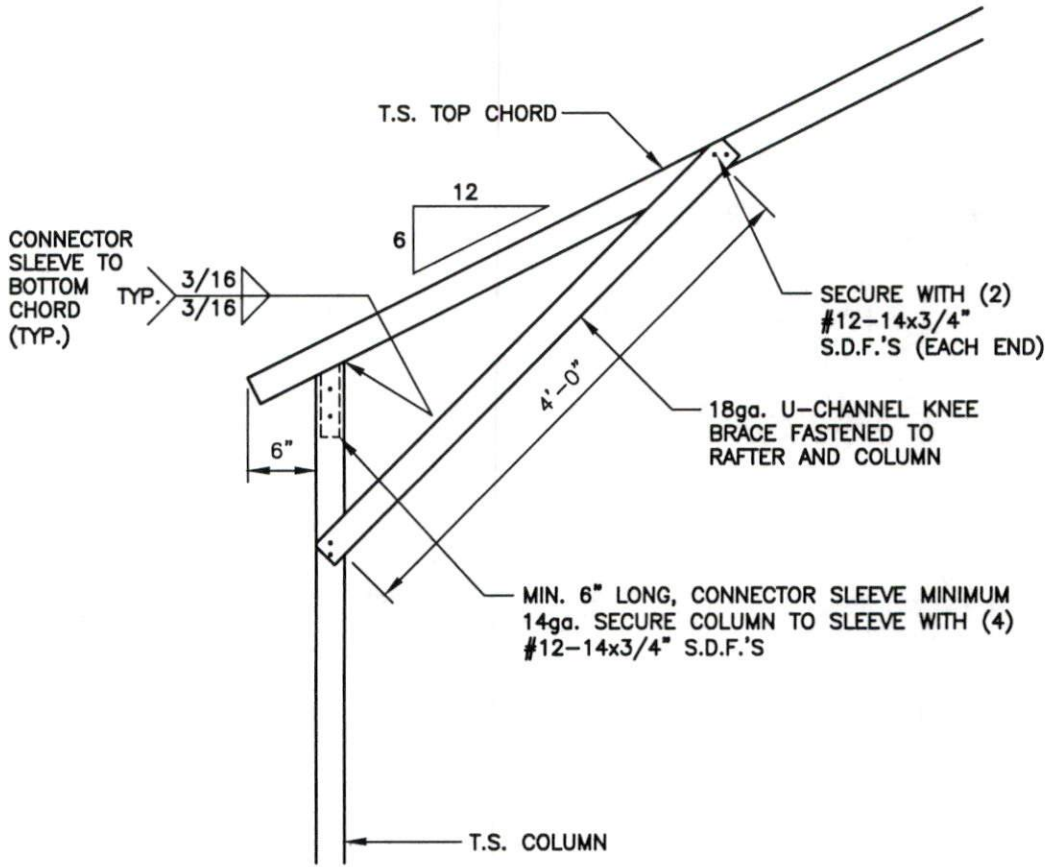

**1** BOX EAVE / CORNER POST CONNECTION DETAIL FOR HEIGHT.S. < 14'-0"

**S6C** SCALE: 3/4" = 1'-0"

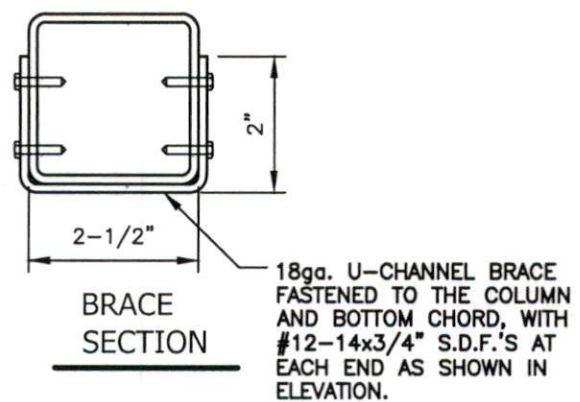

**Taylor & Viola**  
 STRUCTURAL ENGINEERS  
 P.O.B. 2616 HICKORY NORTH CAROLINA  
 TEL: 828-336-6931 FAX: 828-322-1901  
 WWW.TAYLORVIOLA.COM

**JCMT Associates, PLLC**  
 211 Stone Drive, Pilot Mountain, NC 27041  
 Telephone: (336) 399-6277

**NC CARPORTS & GARAGES**

116 EAST MARKET STREET  
 ELKIN, NORTH CAROLINA 28621  
 TELE: 336-368-0668

<b>DRAWN BY:</b> BKS	<b>PROJECT NO:</b> MISC
<b>DATE:</b> 01.23.24	<b>SHEET NO:</b> <b>S6C</b>

NOTE: THESE DRAWINGS ARE VALID FOR (1) CALENDAR YEAR AFTER THE ISSUE DATE LISTED ON THIS SHEET.

## CONCRETE BASE RAIL ANCHORAGE

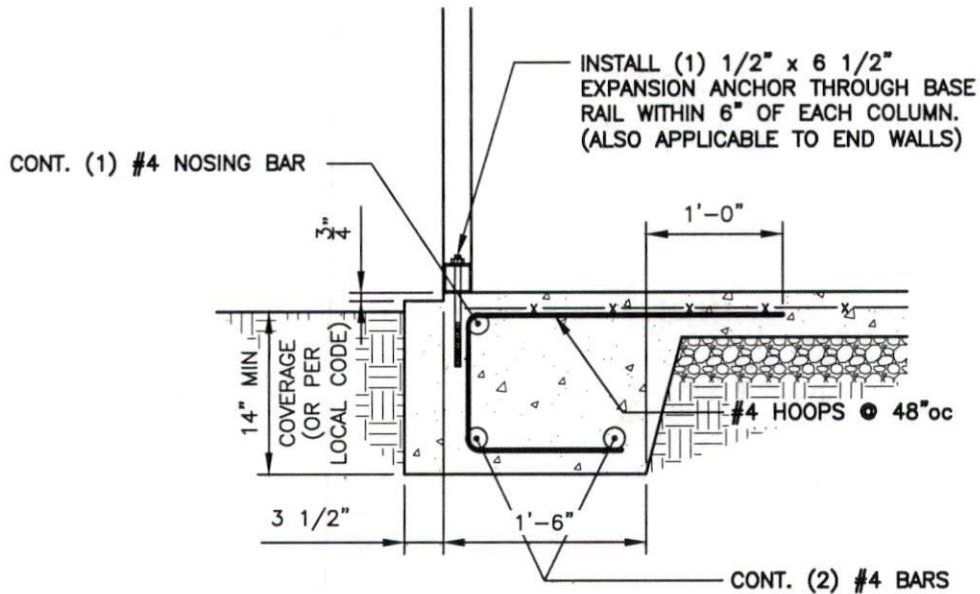

1  
 S7
 

 BASE RAIL ANCHORAGE DETAIL  
 SCALE: 3/4" = 1'-0"

### GENERAL NOTES:

ALL CONCRETE MONOLITHIC SLAB DESIGN BASED ON MINIMUM SOIL BEARING CAPACITY OF 2,000 P.S.F.

#### CONCRETE:

CONCRETE SHALL HAVE A MINIMUM SPECIFIED COMPRESSIVE STRENGTH OF 3,000 P.S.I. AT 28 DAYS.

#### COVER OVER REINFORCING STEEL:

FOR FOUNDATIONS, MINIMUM CONCRETE COVER OVER REINFORCING BARS SHALL BE PER ACI-318: 3" IN FOUNDATIONS WHERE THE CONCRETE IS CAST AGAINST AND PERMANENTLY IN CONTACT WITH THE EARTH OR EXPOSED TO THE EARTH AND WEATHER AND 1-1/2" ELSEWHERE.

#### REINFORCING STEEL:

THE TURNDOWN REINFORCING STEEL SHALL BE ASTM A615 GRADE 60. THE SLAB REINFORCEMENT SHALL BE WELDED WIRE FABRIC MEETING ASTM A185 OR FIBERGLASS FIBER REINFORCEMENT.

#### REINFORCEMENT MAT BE BENT IN THE SHOP OF THE FIELD PROVIDED:

1. REINFORCEMENT IS BENT COLD.
2. THE DIAMETER OF THE BEND, MEASURED ON THE INSIDE OF THE BAR, IS NOT LESS THAN SIX-BAR DIAMETERS.
3. REINFORCEMENT PARTIALLY EMBEDDED IN CONCRETE SHALL NOT BE FIELD BENT.

**TAYLOR & VIOLA**  
 STRUCTURAL ENGINEERS  
 P.O.B. 2616 HICKORY NORTH CAROLINA  
 TELE: 828-338-6331 FAX: 828-322-1501  
 WWW.TAYLORVIOLA.COM  
**JCMT Associates, PLLC**  
 211 Stone Drive, Pilot Mountain, NC 27041  
 Telephone: (336) 399-6277

**NC CARPORTS  
& GARAGES**  
 116 EAST MARKET STREET  
 ELKIN, NORTH CAROLINA 28621  
 TELE: 336-368-0668

DRAWN BY:  
 BKS

PROJECT NO:  
 MISC

DATE:  
 01.23.24

SHEET NO:  
**S7**

NOTE: THESE DRAWINGS ARE VALID FOR (1) CALENDAR YEAR AFTER THE ISSUE DATE LISTED ON THIS SHEET.

CONCRETE BASE RAIL ANCHORAGE (NO SLAB)

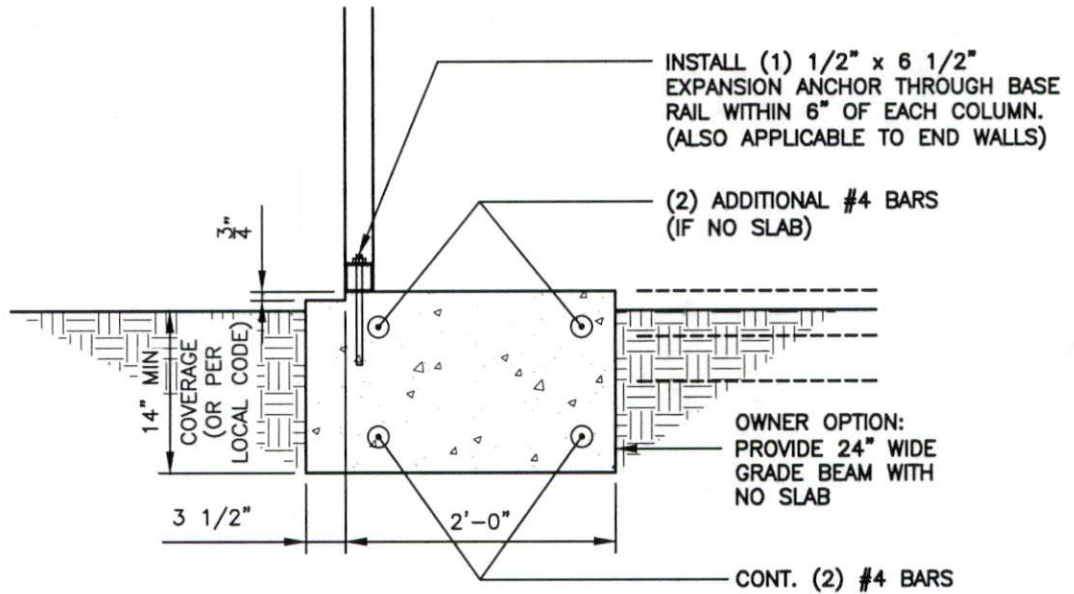

**1** BASE RAIL ANCHORAGE DETAIL  
S7A SCALE: 3/4" = 1'-0"

**GENERAL NOTES:**

ALL CONCRETE MONOLITHIC SLAB DESIGN BASED ON MINIMUM SOIL BEARING CAPACITY OF 2,000 P.S.F.

**CONCRETE:**

CONCRETE SHALL HAVE A MINIMUM SPECIFIED COMPRESSIVE STRENGTH OF 3,000 P.S.I. AT 28 DAYS.

**COVER OVER REINFORCING STEEL:**

FOR FOUNDATIONS, MINIMUM CONCRETE COVER OVER REINFORCING BARS SHALL BE PER ACI-318: 3" IN FOUNDATIONS WHERE THE CONCRETE IS CAST AGAINST AND PERMANENTLY IN CONTACT WITH THE EARTH OR EXPOSED TO THE EARTH AND WEATHER AND 1-1/2" ELSEWHERE.

**REINFORCING STEEL:**

THE TURNDOWN REINFORCING STEEL SHALL BE ASTM A615 GRADE 60. THE SLAB REINFORCEMENT SHALL BE WELDED WIRE FABRIC MEETING ASTM A185 OR FIBERGLASS FIBER REINFORCEMENT.

**REINFORCEMENT MAT BE BENT IN THE SHOP OF THE FIELD PROVIDED:**

1. REINFORCEMENT IS BENT COLD.
2. THE DIAMETER OF THE BEND, MEASURED ON THE INSIDE OF THE BAR, IS NOT LESS THAN SIX-BAR DIAMETERS.
3. REINFORCEMENT PARTIALLY EMBEDDED IN CONCRETE SHALL NOT BE FIELD BENT.

**TAYLOR & VIOLA**  
STRUCTURAL ENGINEERS  
P.O.B. 2616 HICKORY NORTH CAROLINA  
TELE: 828-388-6331 FAX: 828-322-1801  
WWW.TAYLORVIOLA.COM

JCMT Associates, PLLC  
211 Stone Drive, Pilot Mountain, NC 27041  
Telephone: (336) 399-6277

NC CARPORTS  
& GARAGES  
116 EAST MARKET STREET  
ELKIN, NORTH CAROLINA 28621  
TELE: 336-368-0668

DRAWN BY:  
BKS

PROJECT NO:  
MISC

DATE:  
01.23.24

SHEET NO:  
**S7A**

NOTE: THESE DRAWINGS ARE VALID FOR (1) CALENDAR YEAR AFTER THE ISSUE DATE LISTED ON THIS SHEET.

## CONCRETE BASE RAIL ANCHORAGE

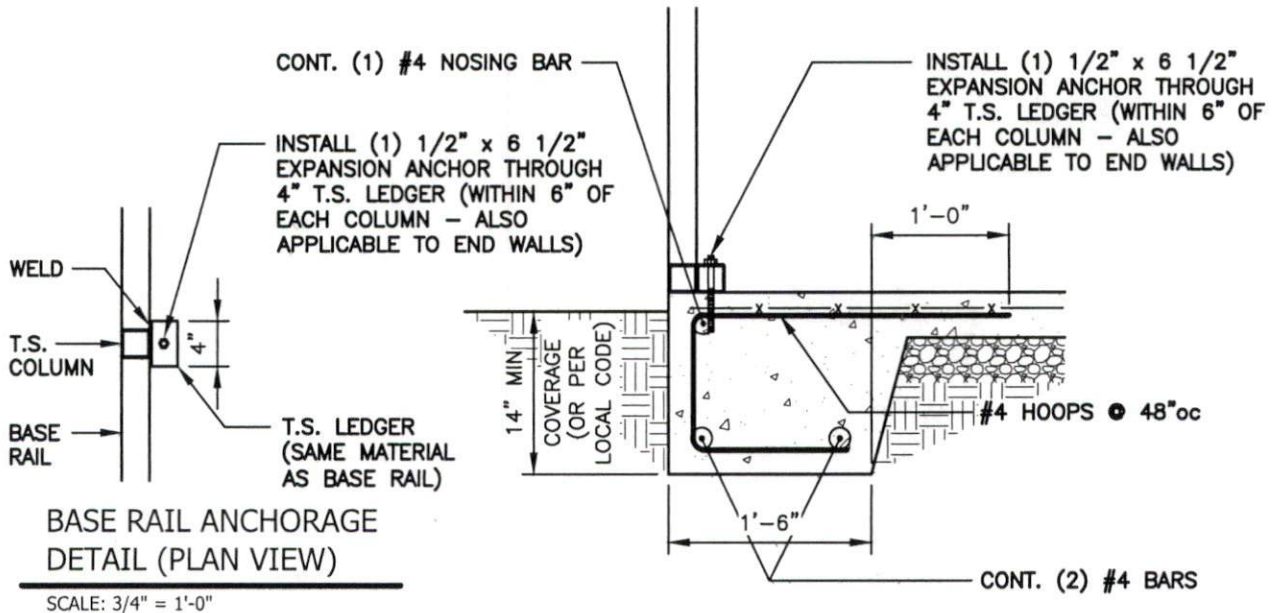

### 1 BASE RAIL ANCHORAGE DETAIL

SCALE: 3/4" = 1'-0"

**GENERAL NOTES:**

ALL CONCRETE MONOLITHIC SLAB DESIGN BASED ON MINIMUM SOIL BEARING CAPACITY OF 2,000 P.S.F.

**CONCRETE:**

CONCRETE SHALL HAVE A MINIMUM SPECIFIED COMPRESSIVE STRENGTH OF 3,000 P.S.I. AT 28 DAYS.

**COVER OVER REINFORCING STEEL:**

FOR FOUNDATIONS, MINIMUM CONCRETE COVER OVER REINFORCING BARS SHALL BE PER ACI-318: 3" IN FOUNDATIONS WHERE THE CONCRETE IS CAST AGAINST AND PERMANENTLY IN CONTACT WITH THE EARTH OR EXPOSED TO THE EARTH AND WEATHER AND 1-1/2" ELSEWHERE.

**REINFORCING STEEL:**

THE TURNDOWN REINFORCING STEEL SHALL BE ASTM A615 GRADE 60. THE SLAB REINFORCEMENT SHALL BE WELDED WIRE FABRIC MEETING ASTM A185 OR FIBERGLASS FIBER REINFORCEMENT.

**REINFORCEMENT MAT BE BENT IN THE SHOP OF THE FIELD PROVIDED:**

1. REINFORCEMENT IS BENT COLD.
2. THE DIAMETER OF THE BEND, MEASURED ON THE INSIDE OF THE BAR, IS NOT LESS THAN SIX-BAR DIAMETERS.
3. REINFORCEMENT PARTIALLY EMBEDDED IN CONCRETE SHALL NOT BE FIELD BENT.

**TAYLOR & VIOLA**  
STRUCTURAL ENGINEERS  
P.O.B. 2616 HICKORY NORTH CAROLINA  
TELE: 828-388-6331 FAX: 828-322-1901  
WWW.TAYLORVIOLA.COM

JCMT Associates, PLLC  
211 Stone Drive, Pilot Mountain, NC 27041  
Telephone: (336) 399-6277

NC CARPORTS  
& GARAGES

116 EAST MARKET STREET  
ELKIN, NORTH CAROLINA 28621  
TELE: 336-368-0668

DRAWN BY:  
BKS

PROJECT NO:  
MISC

DATE:  
01.23.24

SHEET NO:  
**S7B**

NOTE: THESE DRAWINGS ARE VALID FOR (1) CALENDAR YEAR AFTER THE ISSUE DATE LISTED ON THIS SHEET.



CONCRETE BASE RAIL ANCHORAGE (NO SLAB)

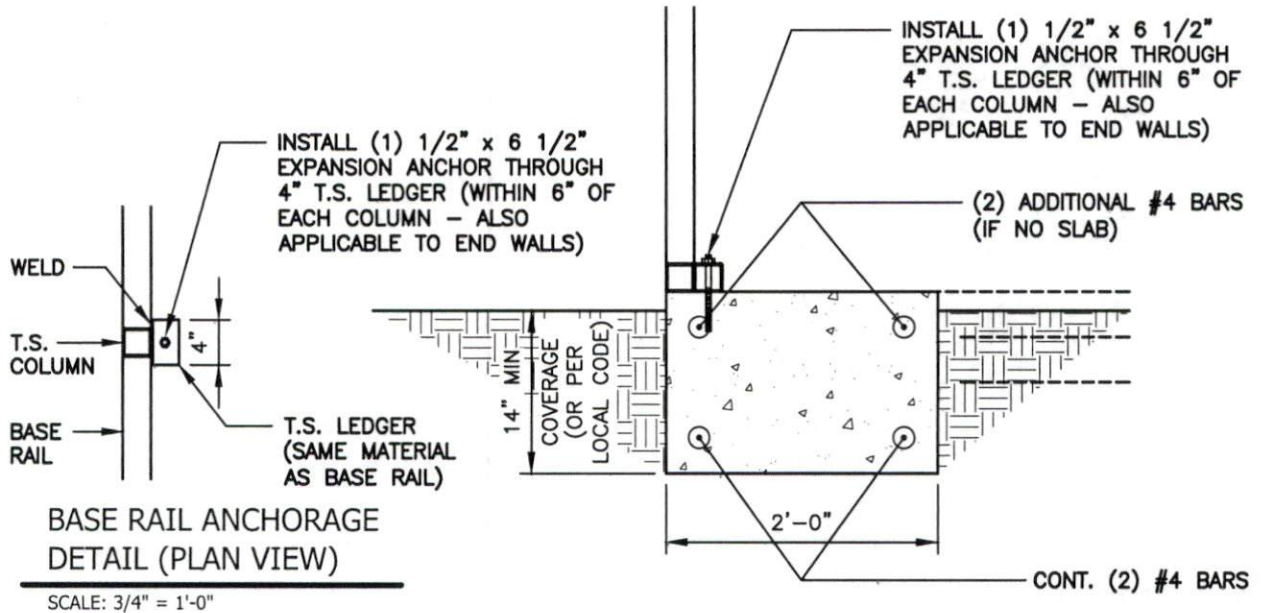

1
S7C
**BASE RAIL ANCHORAGE DETAIL**  
 SCALE: 3/4" = 1'-0"

**GENERAL NOTES:**

ALL CONCRETE MONOLITHIC SLAB DESIGN BASED ON MINIMUM SOIL BEARING CAPACITY OF 2,000 P.S.F.

**CONCRETE:**

CONCRETE SHALL HAVE A MINIMUM SPECIFIED COMPRESSIVE STRENGTH OF 3,000 P.S.I. AT 28 DAYS.

**COVER OVER REINFORCING STEEL:**

FOR FOUNDATIONS, MINIMUM CONCRETE COVER OVER REINFORCING BARS SHALL BE PER ACI-318: 3" IN FOUNDATIONS WHERE THE CONCRETE IS CAST AGAINST AND PERMANENTLY IN CONTACT WITH THE EARTH OR EXPOSED TO THE EARTH AND WEATHER AND 1-1/2" ELSEWHERE.

**REINFORCING STEEL:**

THE TURNDOWN REINFORCING STEEL SHALL BE ASTM A615 GRADE 60. THE SLAB REINFORCEMENT SHALL BE WELDED WIRE FABRIC MEETING ASTM A185 OR FIBERGLASS FIBER REINFORCEMENT.

**REINFORCEMENT MAT BE BENT IN THE SHOP OF THE FIELD PROVIDED:**

1. REINFORCEMENT IS BENT COLD.
2. THE DIAMETER OF THE BEND, MEASURED ON THE INSIDE OF THE BAR, IS NOT LESS THAN SIX-BAR DIAMETERS.
3. REINFORCEMENT PARTIALLY EMBEDDED IN CONCRETE SHALL NOT BE FIELD BENT.

**TAYLOR & VIOLA**  
 STRUCTURAL ENGINEERS  
 P.O.B. 7616 HICKORY NORTH CAROLINA  
 TELE: 828-328-6331 FAX: 828-322-1901  
 WWW.TAYLORVIOLA.COM  
**JCMT Associates, PLLC**  
 211 Stone Drive, Pilot Mountain, NC 27041  
 Telephone: (336) 399-6277

**NC CARPORTS**  
**& GARAGES**  
 116 EAST MARKET STREET  
 ELKIN, NORTH CAROLINA 28621  
 TELE: 336-368-0668

**DRAWN BY:**  
BKS

**PROJECT NO:**  
MISC

**DATE:**  
01.23.24

**SHEET NO:**  
**S7C**

## CONCRETE BASE RAIL ANCHORAGE

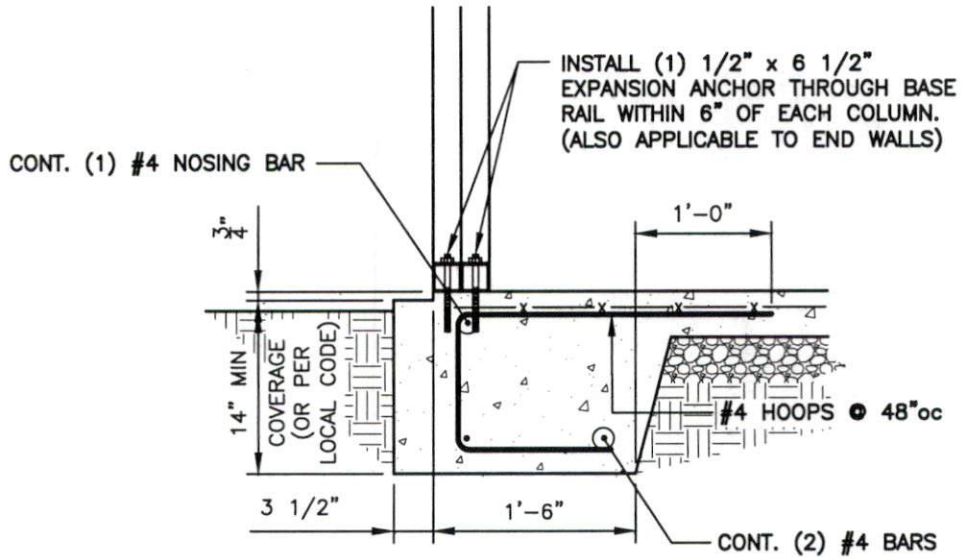

1
S7D
**BASE RAIL ANCHORAGE DETAIL**  
 SCALE: 3/4" = 1'-0"

**GENERAL NOTES:**

ALL CONCRETE MONOLITHIC SLAB DESIGN BASED ON MINIMUM SOIL BEARING CAPACITY OF 2,000 P.S.F.

**CONCRETE:**

CONCRETE SHALL HAVE A MINIMUM SPECIFIED COMPRESSIVE STRENGTH OF 3,000 P.S.I. AT 28 DAYS.

**COVER OVER REINFORCING STEEL:**

FOR FOUNDATIONS, MINIMUM CONCRETE COVER OVER REINFORCING BARS SHALL BE PER ACI-318: 3" IN FOUNDATIONS WHERE THE CONCRETE IS CAST AGAINST AND PERMANENTLY IN CONTACT WITH THE EARTH OR EXPOSED TO THE EARTH AND WEATHER AND 1-1/2" ELSEWHERE.

**REINFORCING STEEL:**

THE TURNDOWN REINFORCING STEEL SHALL BE ASTM A615 GRADE 60. THE SLAB REINFORCEMENT SHALL BE WELDED WIRE FABRIC MEETING ASTM A185 OR FIBERGLASS FIBER REINFORCEMENT.

**REINFORCEMENT MAT BE BENT IN THE SHOP OF THE FIELD PROVIDED:**

1. REINFORCEMENT IS BENT COLD.
2. THE DIAMETER OF THE BEND, MEASURED ON THE INSIDE OF THE BAR, IS NOT LESS THAN SIX-BAR DIAMETERS.
3. REINFORCEMENT PARTIALLY EMBEDDED IN CONCRETE SHALL NOT BE FIELD BENT.

**TAYLOR & VIOLA**  
 STRUCTURAL ENGINEERS  
P.O. Box 2616 HICKORY NORTH CAROLINA  
 TELE: 828-388-6331 FAX: 828-322-1801  
 WWW.TAYLORVIOLA.COM  
**JCMT Associates, PLLC**  
211 Stone Drive, Pilot Mountain, NC 27041  
 Telephone: (336) 399-6277

**NC CARPORTS  
& GARAGES**  
116 EAST MARKET STREET  
 ELKIN, NORTH CAROLINA 28621  
 TELE: 336-368-0668

**DRAWN BY:**  
BKS

**PROJECT NO:**  
MISC

**DATE:**  
01.23.24

**SHEET NO:**  
**S7D**

NOTE: THESE DRAWINGS ARE VALID FOR (1) CALENDAR YEAR AFTER THE ISSUE DATE LISTED ON THIS SHEET.

CONCRETE BASE RAIL ANCHORAGE (NO SLAB)

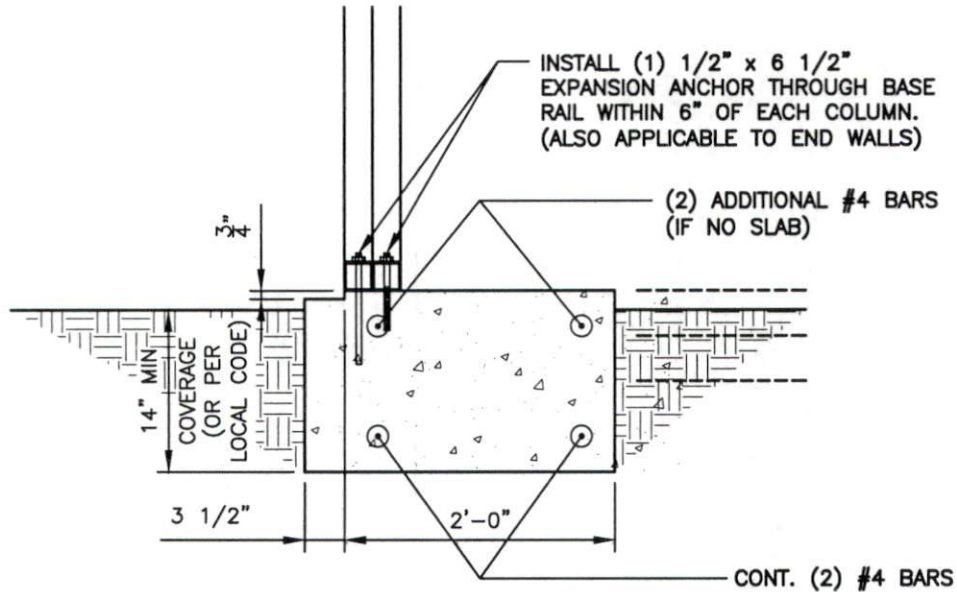

1
S7E
**BASE RAIL ANCHORAGE DETAIL**  
 SCALE: 3/4" = 1'-0"

**GENERAL NOTES:**

ALL CONCRETE MONOLITHIC SLAB DESIGN BASED ON MINIMUM SOIL BEARING CAPACITY OF 2,000 P.S.F.

**CONCRETE:**

CONCRETE SHALL HAVE A MINIMUM SPECIFIED COMPRESSIVE STRENGTH OF 3,000 P.S.I. AT 28 DAYS.

**COVER OVER REINFORCING STEEL:**

FOR FOUNDATIONS, MINIMUM CONCRETE COVER OVER REINFORCING BARS SHALL BE PER ACI-318: 3" IN FOUNDATIONS WHERE THE CONCRETE IS CAST AGAINST AND PERMANENTLY IN CONTACT WITH THE EARTH OR EXPOSED TO THE EARTH AND WEATHER AND 1-1/2" ELSEWHERE.

**REINFORCING STEEL:**

THE TURNDOWN REINFORCING STEEL SHALL BE ASTM A615 GRADE 60. THE SLAB REINFORCEMENT SHALL BE WELDED WIRE FABRIC MEETING ASTM A185 OR FIBERGLASS FIBER REINFORCEMENT.

**REINFORCEMENT MAT BE BENT IN THE SHOP OF THE FIELD PROVIDED:**

1. REINFORCEMENT IS BENT COLD.
2. THE DIAMETER OF THE BEND, MEASURED ON THE INSIDE OF THE BAR, IS NOT LESS THAN SIX-BAR DIAMETERS.
3. REINFORCEMENT PARTIALLY EMBEDDED IN CONCRETE SHALL NOT BE FIELD BENT.

**TAYLOR & VIOLA**  
 STRUCTURAL ENGINEERS  
P.O.B. 2616 HICKORY NORTH CAROLINA  
 TELE: 828-388-6351 FAX: 828-322-1901  
 WWW: TAYLORVIOLA.COM  
**JCMT Associates, PLLC**  
211 Stone Drive, Pilot Mountain, NC 27041  
 Telephone: (336) 399-6277

**NC CARPORTS  
& GARAGES**  
 116 EAST MARKET STREET  
 ELKIN, NORTH CAROLINA 28621  
 TELE: 336-368-0668

**DRAWN BY:**  
BKS

**PROJECT NO:**  
MISC

**DATE:**  
01.23.24

**SHEET NO:**  
**S7E**

## CONCRETE BASE RAIL ANCHORAGE

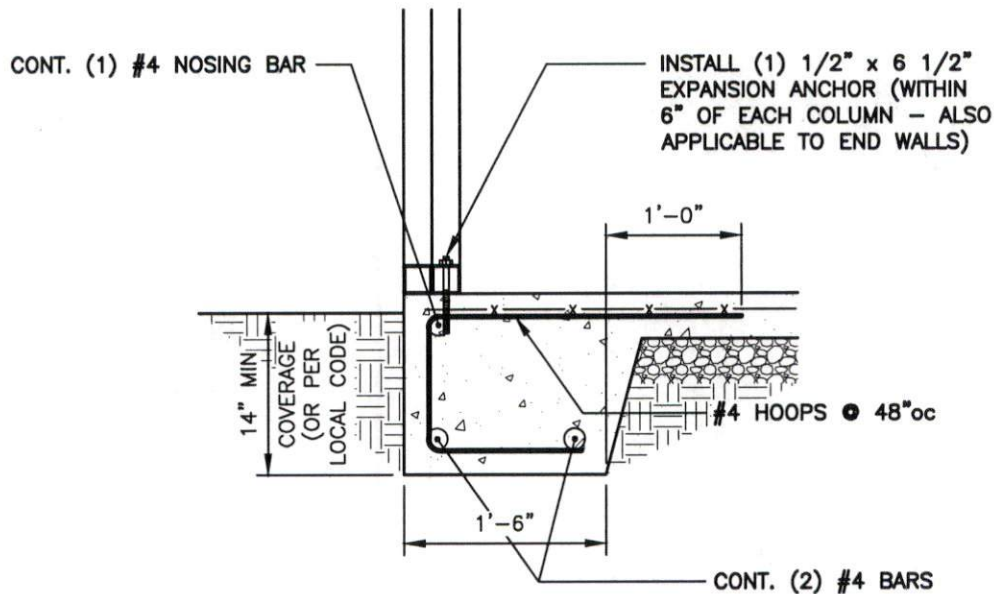

### BASE RAIL ANCHORAGE DETAIL

SCALE: 3/4" = 1'-0"

#### GENERAL NOTES:

ALL CONCRETE MONOLITHIC SLAB DESIGN BASED ON MINIMUM SOIL BEARING CAPACITY OF 2,000 P.S.F.

#### CONCRETE:

CONCRETE SHALL HAVE A MINIMUM SPECIFIED COMPRESSIVE STRENGTH OF 3,000 P.S.I. AT 28 DAYS.

#### COVER OVER REINFORCING STEEL:

FOR FOUNDATIONS, MINIMUM CONCRETE COVER OVER REINFORCING BARS SHALL BE PER ACI-318: 3" IN FOUNDATIONS WHERE THE CONCRETE IS CAST AGAINST AND PERMANENTLY IN CONTACT WITH THE EARTH OR EXPOSED TO THE EARTH AND WEATHER AND 1-1/2" ELSEWHERE.

#### REINFORCING STEEL:

THE TURNDOWN REINFORCING STEEL SHALL BE ASTM A615 GRADE 60. THE SLAB REINFORCEMENT SHALL BE WELDED WIRE FABRIC MEETING ASTM A185 OR FIBERGLASS FIBER REINFORCEMENT.

#### REINFORCEMENT MAT BE BENT IN THE SHOP OF THE FIELD PROVIDED:

1. REINFORCEMENT IS BENT COLD.
2. THE DIAMETER OF THE BEND, MEASURED ON THE INSIDE OF THE BAR, IS NOT LESS THAN SIX-BAR DIAMETERS.
3. REINFORCEMENT PARTIALLY EMBEDDED IN CONCRETE SHALL NOT BE FIELD BENT.

**Taylor & Viola**  
STRUCTURAL ENGINEERS  
P.O.B. 2616 HICKORY NORTH CAROLINA  
TELE: 828-388-6331 FAX: 828-322-1901  
WWW.TAYLORVIOLA.COM

JCMT Associates, PLLC  
211 Stone Drive, Pilot Mountain, NC 27041  
Telephone: (336) 399-6277

NC CARPORTS  
& GARAGES

116 EAST MARKET STREET  
ELKIN, NORTH CAROLINA 28621  
TELE: 336-368-0668

DRAWN BY:  
BKS

PROJECT NO:  
MISC

DATE:  
01.23.24

SHEET NO:  
**S7F**

NOTE: THESE DRAWINGS ARE VALID FOR (1) CALENDAR YEAR AFTER THE ISSUE DATE LISTED ON THIS SHEET.

CONCRETE BASE RAIL ANCHORAGE (NO SLAB)

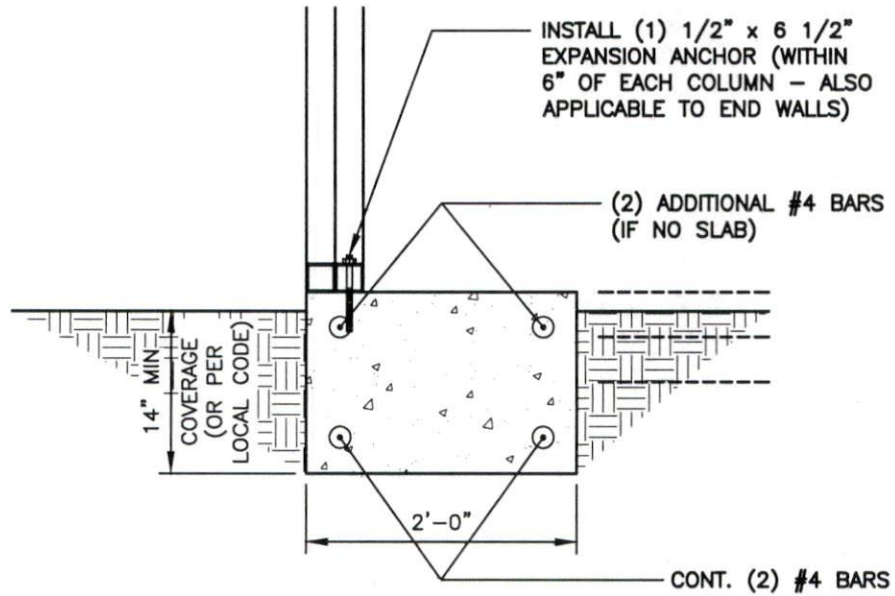

**1** BASE RAIL ANCHORAGE DETAIL  
 S7G SCALE: 3/4" = 1'-0"

**GENERAL NOTES:**

ALL CONCRETE MONOLITHIC SLAB DESIGN BASED ON MINIMUM SOIL BEARING CAPACITY OF 2,000 P.S.F.

**CONCRETE:**

CONCRETE SHALL HAVE A MINIMUM SPECIFIED COMPRESSIVE STRENGTH OF 3,000 P.S.I. AT 28 DAYS.

**COVER OVER REINFORCING STEEL:**

FOR FOUNDATIONS, MINIMUM CONCRETE COVER OVER REINFORCING BARS SHALL BE PER ACI-318: 3" IN FOUNDATIONS WHERE THE CONCRETE IS CAST AGAINST AND PERMANENTLY IN CONTACT WITH THE EARTH OR EXPOSED TO THE EARTH AND WEATHER AND 1-1/2" ELSEWHERE.

**REINFORCING STEEL:**

THE TURNDOWN REINFORCING STEEL SHALL BE ASTM A615 GRADE 60. THE SLAB REINFORCEMENT SHALL BE WELDED WIRE FABRIC MEETING ASTM A185 OR FIBERGLASS FIBER REINFORCEMENT.

**REINFORCEMENT MAT BE BENT IN THE SHOP OF THE FIELD PROVIDED:**

1. REINFORCEMENT IS BENT COLD.
2. THE DIAMETER OF THE BEND, MEASURED ON THE INSIDE OF THE BAR, IS NOT LESS THAN SIX-BAR DIAMETERS.
3. REINFORCEMENT PARTIALLY EMBEDDED IN CONCRETE SHALL NOT BE FIELD BENT.

**TAYLOR & VIOLA**  
 STRUCTURAL ENGINEERS  
 P.O.B. 2616 HICKORY NORTH CAROLINA  
 TELE: 828-328-6931 FAX: 828-322-1801  
 WWW.TAYLORVIOLA.COM

JCMT Associates, PLLC  
 211 Stone Drive, Pilot Mountain, NC 27041  
 Telephone: (336) 399-6277

**NC CARPORTS  
 & GARAGES**

116 EAST MARKET STREET  
 ELKIN, NORTH CAROLINA 28621  
 TELE: 336-368-0668

**DRAWN BY:**  
BKS

**PROJECT NO:**  
MISC

**DATE:**  
01.23.24

**SHEET NO:**  
**S7G**

## SOIL NAIL BASE RAIL ANCHORAGE

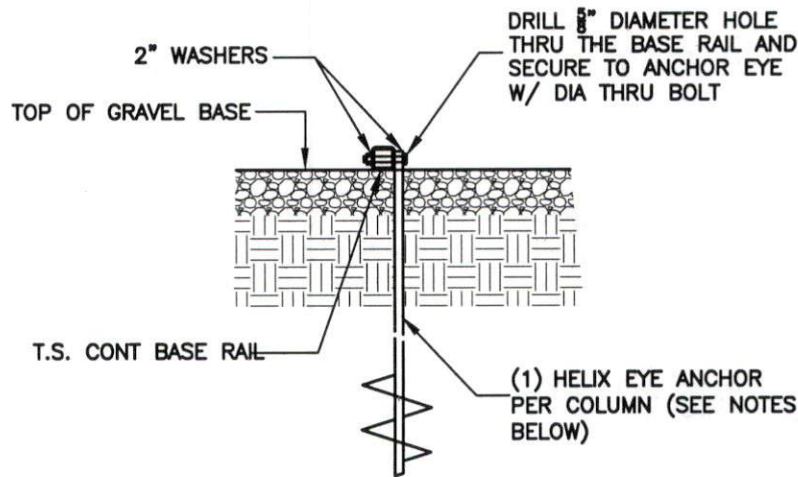

### BASE RAIL ANCHORAGE DETAIL

SCALE: 3/4" = 1'-0"

#### HELIX EMBEDMENT INFORMATION:

FOR VERY DENSE OR CEMETED SANDS, COARSE GRAVEL, COBBLES, CALICHE, PRELOADED SILT.S. AND CLAYS, USE MIN. (2) 4" HELICES WITH MINIMUM 30" EMBEDMENT OR SINGLE 6" HELIX WITH 50" EMBEDMENT - ONE EACH END BASE RAIL AND 20'-0"oc MAX. WITH #4 REBAR AT 5'-0"oc BETWEEN.

FOR CORAL, USE MIN (2) 4" HELICES WITH MINIMUM 30" EMBEDMENT OR SINGLE 6" HELIX WITH 50" EMBEDMENT - ONE EACH END BASE RAIL AND 20'-0"oc MAX. WITH #4 REBAR AT 5'-0"oc BETWEEN.

FOR MED DENSE COARSE SANDS, SANDY GRAVEL, VERY STIFF SILT.S., AND CLAYS, USE MIN (2) 4" HELICES WITH MINIMUM 30" EMBEDMENT OR SINGLE 6" HELIX WITH 50" EMBEDMENT - ONE EACH END BASE RAIL AND 20'-0"oc MAX. WITH #4 REBAR AT 5'-0"oc BETWEEN.

FOR LOOSE TO MEDIUM DENSE SANDS, FIRM TO STIFF CLAYS AND SILT.S., USE MIN (2) 6" HELICES WITH MINIMUM 50" EMBEDMENT - ONE EACH END BASE RAIL AND 20'-0"oc MAX. WITH #4 REBAR AT 5'-0"oc BETWEEN.

FOR VERY LOOSE TO MEDIUM DENSE SANDS, FIRM TO STIFFER CLAYS AND SILT.S. AND ALLUVIAL FILL, USE MIN (2) 8" HELICES WITH MINIMUM 60" EMBEDMENT - ONE EACH END BASE RAIL AND 20'-0"oc MAX. WITH #4 REBAR AT 5'-0"oc BETWEEN.

#### NOTE:

IN ALL CASES, IF FROST DEPTH EXCEEDS STATED DEPTH, ANCHOR SHOULD EXTEND A MIN. OF 12" BELOW FROST LINE.

**TAYLOR & VIOLA**  
STRUCTURAL ENGINEERS  
P.O.B. 2616 HICKORY NORTH CAROLINA  
TELE: 828-328-6931 FAX: 828-322-1901  
WWW.TAYLORVIOLA.COM

JCMT Associates, PLLC  
211 Stone Drive, Pilot Mountain, NC 27041  
Telephone: (336) 399-6277

NC CARPORTS  
& GARAGES

116 EAST MARKET STREET  
ELKIN, NORTH CAROLINA 28621  
TELE: 336-368-0668

DRAWN BY:  
BKS

PROJECT NO:  
MISC

DATE:  
01.23.24

SHEET NO:  
S8

NOTE: THESE DRAWINGS ARE VALID FOR (1) CALENDAR YEAR AFTER THE ISSUE DATE LISTED ON THIS SHEET.

ASPHALT ANCHOR BASE RAIL ANCHORAGE

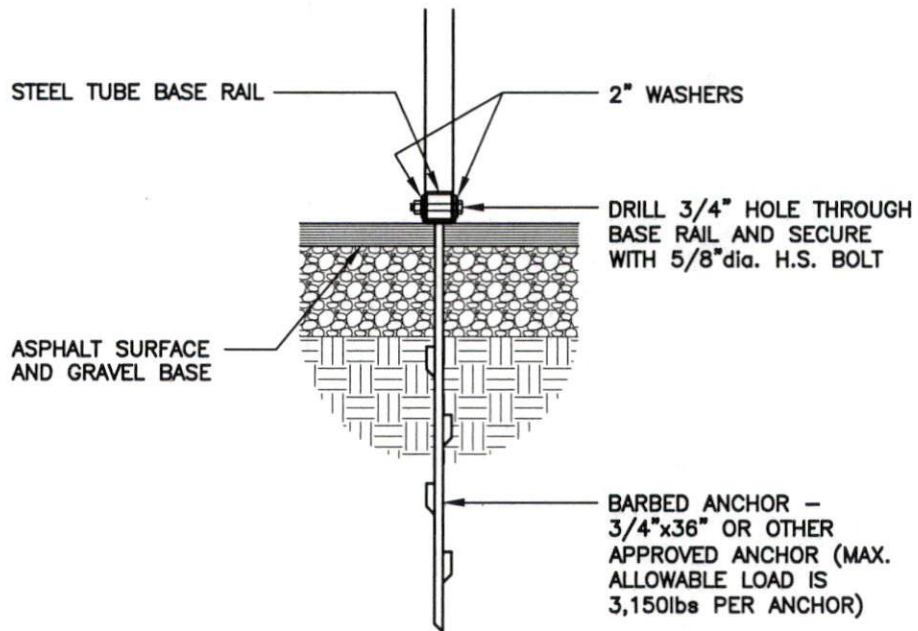

**1** ASPHALT / BASE RAIL ANCHORAGE DETAIL  
**SBA** SCALE: 3/4" = 1'-0"

**TAYLOR & VIOLA**  
 STRUCTURAL ENGINEERS  
 P.O.B. 2616 HICKORY NORTH CAROLINA  
 TELE: 828-326-6931 FAX: 828-322-1801  
 WWW.TAYLORVIOLA.COM  
**JCMT Associates, PLLC**  
 211 Stone Drive, Pilot Mountain, NC 27041  
 Telephone: (336) 399-6277

**NC CARPORTS & GARAGES**  
 116 EAST MARKET STREET  
 ELKIN, NORTH CAROLINA 28621  
 TELE: 336-368-0668

**DRAWN BY:**  
 BKS

**PROJECT NO:**  
 MISC

**DATE:**  
 01.23.24

**SHEET NO:**  
**SBA**

NOTE: THESE DRAWINGS ARE VALID FOR (1) CALENDAR YEAR AFTER THE ISSUE DATE LISTED ON THIS SHEET.

BOX EVE RAFTER END WALL OPENINGS

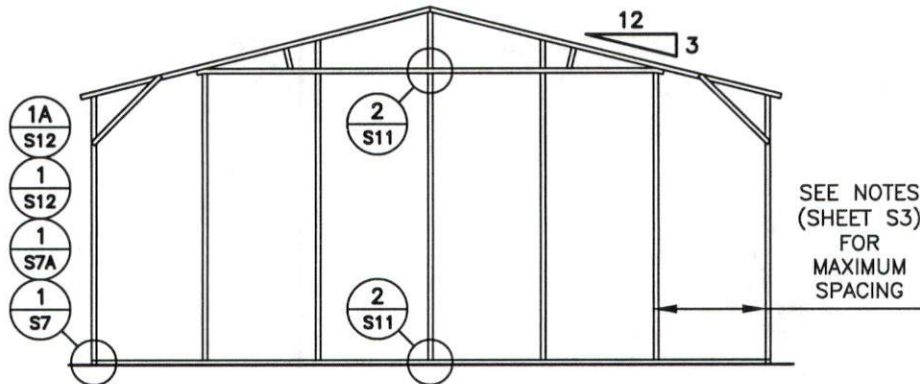

TYPICAL BOX EVE RAFTER / END WALL COLUMN FRAME SECTION

**NOTE:**  
 ROLL UP DOORS SHALL  
 HAVE ONE JAMB EACH  
 SIDE + ONE FRAME  
 COLUMN BETWEEN OR SITE  
 SPECIFIC SHALL BE REQ'D.

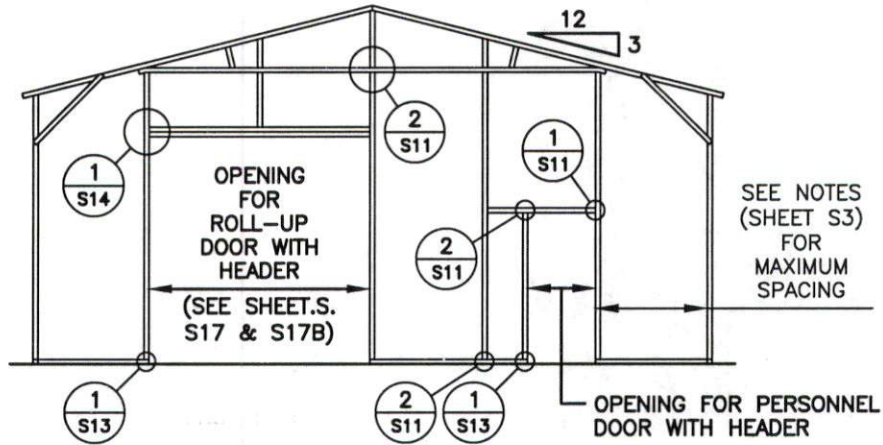

TYPICAL BOX EVE RAFTER END WALL OPENINGS FRAMING SECTION

**TAYLOR & VIOLA**  
 STRUCTURAL ENGINEERS  
 P.O.B. 2616 HICKORY NORTH CAROLINA  
 TELE: 828-328-6331 FAX: 828-322-1901  
 WWW.TAYLORVIOLA.COM

**JCMT Associates, PLLC**  
 211 Stone Drive, Pilot Mountain, NC 27041  
 Telephone: (336) 399-6277

**NC CARPORTS  
 & GARAGES**

116 EAST MARKET STREET  
 ELKIN, NORTH CAROLINA 28621  
 TELE: 336-368-0668

**DRAWN BY:**  
 BKS

**PROJECT NO:**  
 MISC

**DATE:**  
 01.23.24

**SHEET NO:**  
**S9**

NOTE: THESE DRAWINGS ARE VALID FOR (1) CALENDAR YEAR AFTER THE ISSUE DATE LISTED ON THIS SHEET.



## BOX EVE RAFTER END WALL AND SIDE WALL OPENINGS

**NOTE:**  
 ROLL UP DOORS SHALL HAVE ONE JAMB  
 EACH SIDE + ONE FRAME COLUMN BETWEEN  
 OR SITE SPECIFIC SHALL BE REQ'D.

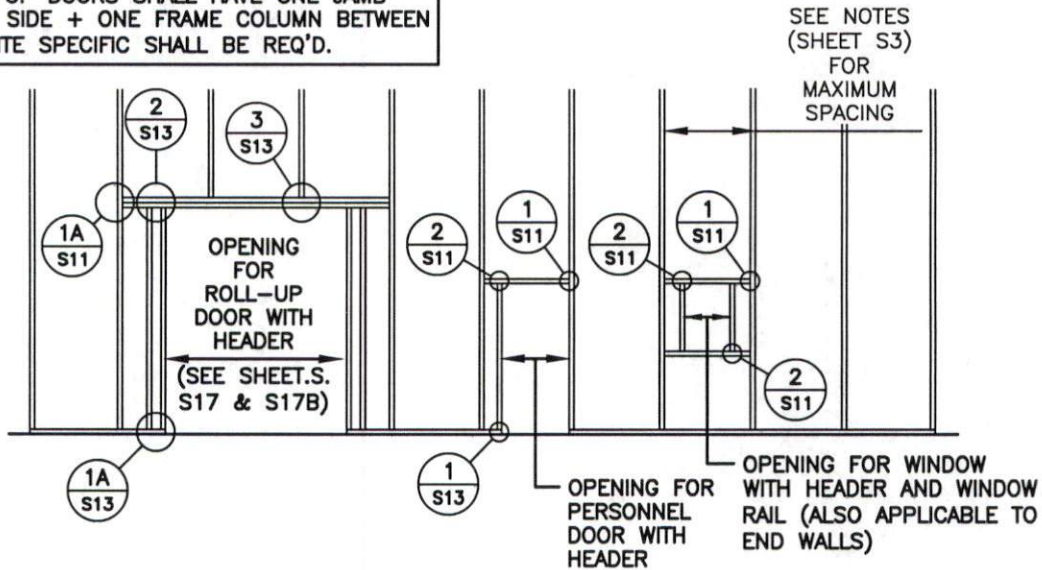

### TYPICAL END WALL OPENING FRAMING SECTION

**NOTE:**  
 ROLL UP DOORS SHALL HAVE ONE JAMB  
 EACH SIDE + ONE FRAME COLUMN BETWEEN  
 OR SITE SPECIFIC SHALL BE REQ'D.

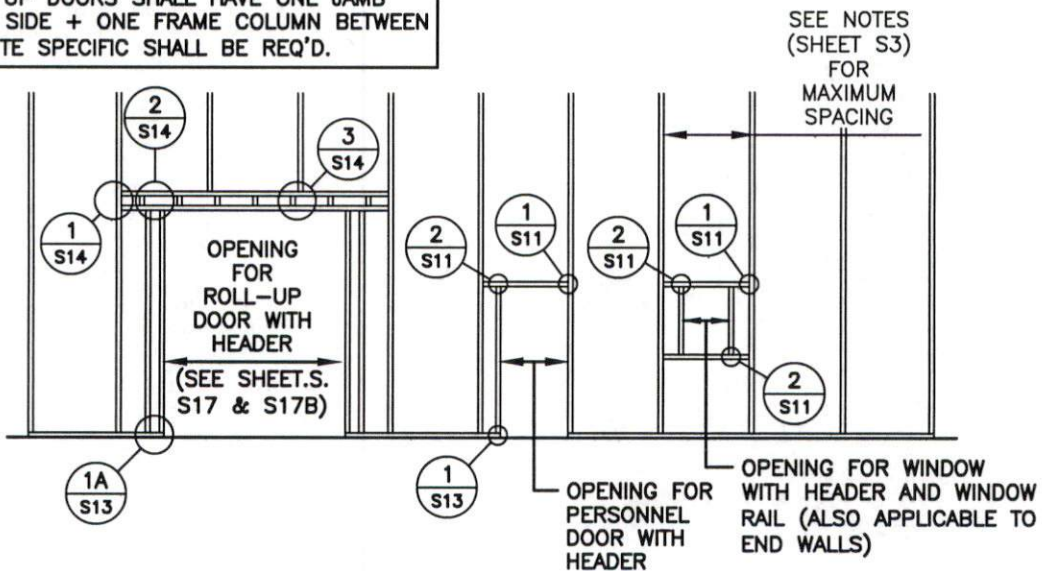

### TYPICAL SIDE WALL OPENING FRAMING SECTION

**TAYLOR & VIOLA**  
 STRUCTURAL ENGINEERS  
 P.O.B. 2616 HICKORY NORTH CAROLINA  
 TELE: 828-328-6331 FAX: 828-322-1801  
 WWW.TAYLORVIOLA.COM

**JCMT Associates, PLLC**  
 211 Stone Drive, Pilot Mountain, NC 27041  
 Telephone: (336) 399-6277

**NC CARPORTS & GARAGES**  
 116 EAST MARKET STREET  
 ELKIN, NORTH CAROLINA 28621  
 TELE: 336-368-0668

**DRAWN BY:**  
 BKS

**PROJECT NO:**  
 MISC

**DATE:**  
 01.23.24

**SHEET NO:**  
**S9A**

NOTE: THESE DRAWINGS ARE VALID FOR (1) CALENDAR YEAR AFTER THE ISSUE DATE LISTED ON THIS SHEET.

## CONNECTION DETAILS

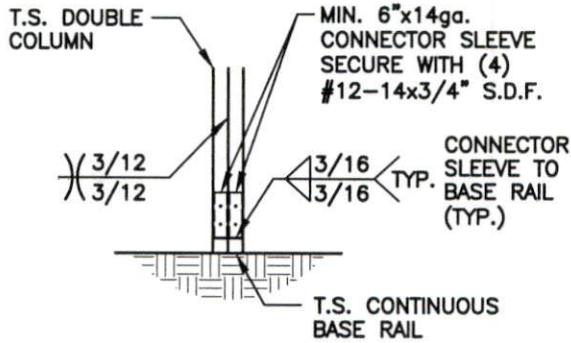

**1**  
S10 SCALE: 1/2" = 1'-0"

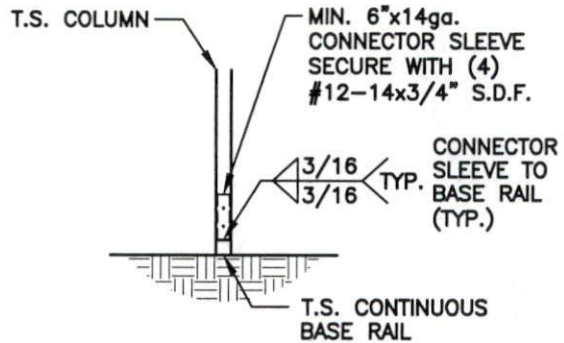

**1A**  
S10 SCALE: 1/2" = 1'-0"

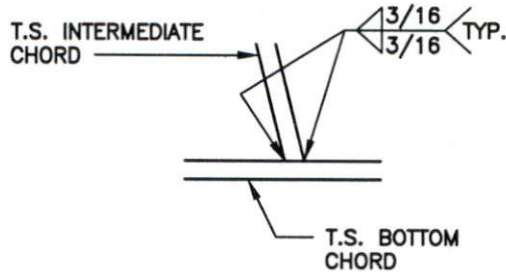

**2**  
S10 SCALE: 1/2" = 1'-0"

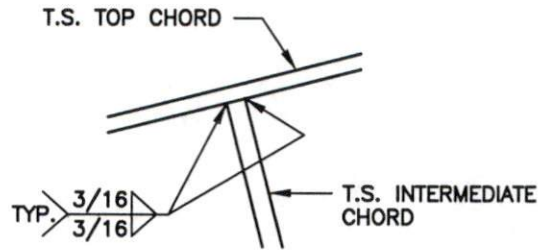

**3**  
S10 SCALE: 1/2" = 1'-0"

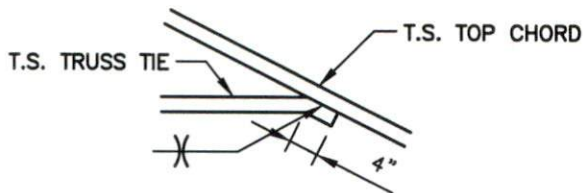

**4**  
S10 SCALE: 1/2" = 1'-0"

**Taylor & Viola**  
STRUCTURAL ENGINEERS  
P.O.B. 2616 HICKORY NORTH CAROLINA  
TELE: 828-328-6331 FAX: 828-322-1801  
WWW.TAYLORVIOLA.COM

JCMT Associates, PLLC  
211 Stone Drive, Pilot Mountain, NC 27041  
Telephone: (336) 399-6277

NC CARPORTS  
& GARAGES  
116 EAST MARKET STREET  
ELKIN, NORTH CAROLINA 28621  
TELE: 336-368-0668

DRAWN BY:  
BKS

PROJECT NO:  
MISC

DATE:  
01.23.24

SHEET NO:  
**S10**

NOTE: THESE DRAWINGS ARE VALID FOR (1) CALENDAR YEAR AFTER THE ISSUE DATE LISTED ON THIS SHEET.

CONNECTION DETAILS

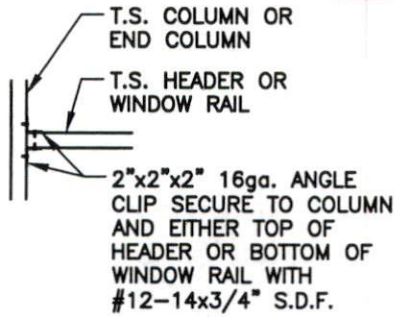

COLUMN OR WINDOW  
RAIL / WALL GIRT TO POST  
CONNECTION DETAIL

1  
S11

SCALE: 1/2" = 1'-0"

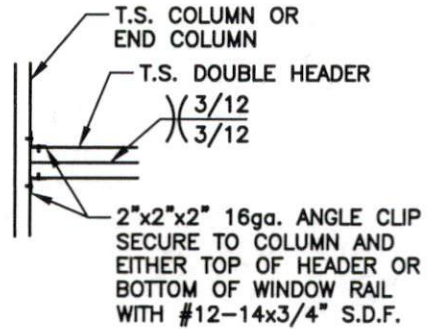

COLUMN / DOUBLE HEADER  
CONNECTION DETAIL

1A  
S11

SCALE: 1/2" = 1'-0"

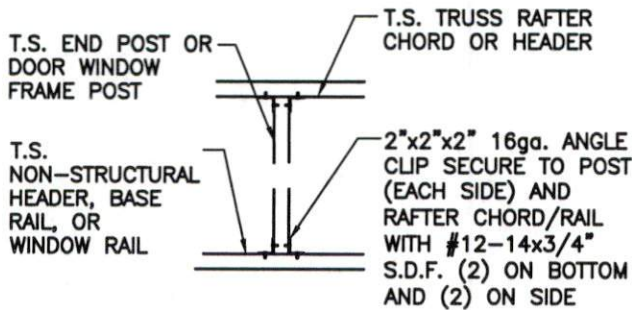

DOOR OR WINDOW HEADER  
RAIL TO POST CONNECTION  
DETAIL

2  
S11

SCALE: 1/2" = 1'-0"



**TAYLOR & VIOLA**  
STRUCTURAL ENGINEERS  
P.O.B. 2616 HICKORY NORTH CAROLINA  
TELE: 828-326-6331 FAX: 828-322-1801  
WWW.TAYLORVIOLA.COM

JCMT Associates, PLLC  
211 Stone Drive, Pilot Mountain, NC 27041  
Telephone: (336) 399-6277

NC CARPORTS  
& GARAGES

116 EAST MARKET STREET  
ELKIN, NORTH CAROLINA 28621  
TELE: 336-368-0668

DRAWN BY:  
BKS

PROJECT NO:  
MISC

DATE:  
01.23.24

SHEET NO:  
**S11**

NOTE: THESE DRAWINGS ARE VALID FOR (1) CALENDAR YEAR AFTER THE ISSUE DATE LISTED ON THIS SHEET.

CONNECTION DETAILS

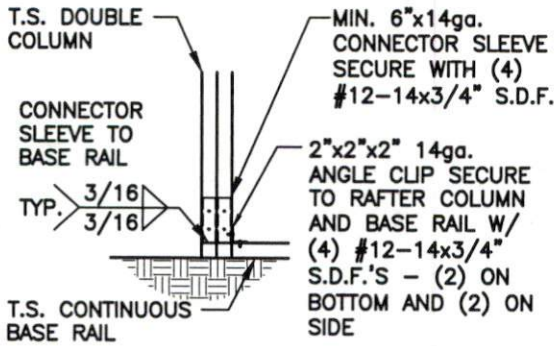

END COLUMN / BASE RAIL  
CONNECTION DETAIL

1  
S12

SCALE: 1/2" = 1'-0"

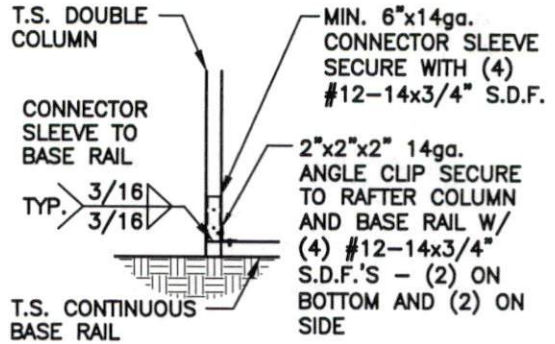

END COLUMN / BASE RAIL  
CONNECTION DETAIL

1A  
S12

SCALE: 1/2" = 1'-0"



**TAYLOR & VIOLA**  
STRUCTURAL ENGINEERS  
P.O.B. 2616 HICKORY NORTH CAROLINA  
TELE: 828-328-6831 FAX: 828-322-1991  
WWW.TAYLORVIOLA.COM

JCMT Associates, PLLC  
211 Stone Drive, Pilot Mountain, NC 27041  
Telephone: (336) 399-6277

NC CARPORTS  
& GARAGES

116 EAST MARKET STREET  
ELKIN, NORTH CAROLINA 28621  
TELE: 336-368-0668

DRAWN BY:  
BKS

PROJECT NO:  
MISC

DATE:  
01.23.24

SHEET NO:  
**S12**

NOTE: THESE DRAWINGS ARE VALID FOR (1) CALENDAR YEAR AFTER THE ISSUE DATE LISTED ON THIS SHEET.

## CONNECTION DETAILS

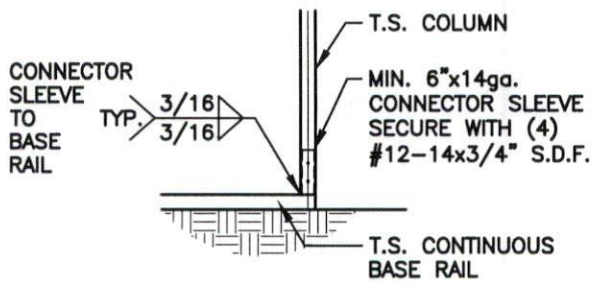

**1**  
COLUMN / BASE RAIL CONNECTION DETAIL

**S13**

SCALE: 1/2" = 1'-0"

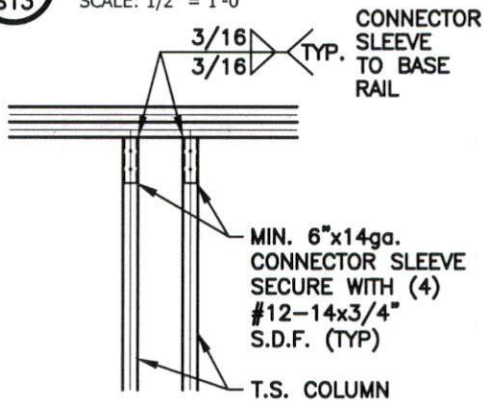

**2**  
DOUBLE HEADER / COLUMN CONNECTION DETAIL

**S13**

SCALE: 1/2" = 1'-0"

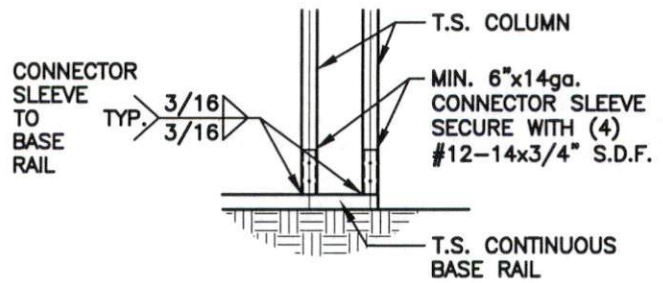

**1A**  
COLUMN / BASE RAIL CONNECTION DETAIL

**S13**

SCALE: 1/2" = 1'-0"

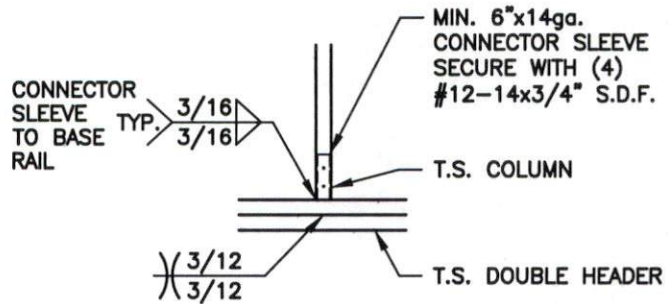

**3**  
COLUMN / DOUBLE HEADER CONNECTION DETAIL

**S13**

SCALE: 1/2" = 1'-0"

**Taylor & Viola**  
STRUCTURAL ENGINEERS  
P.O.B. 2616 HICKORY NORTH CAROLINA  
TELE: 828-328-6331 FAX: 828-322-1801  
WWW.TAYLORVIOLA.COM

JCMT Associates, PLLC  
211 Stone Drive, Pilot Mountain, NC 27041  
Telephone: (336) 399-6277

NC CARPORTS  
& GARAGES

116 EAST MARKET STREET  
ELKIN, NORTH CAROLINA 28621  
TELE: 336-368-0668

DRAWN BY:  
BKS

PROJECT NO:  
MISC

DATE:  
01.23.24

SHEET NO:  
**S13**

NOTE: THESE DRAWINGS ARE VALID FOR (1) CALENDAR YEAR AFTER THE ISSUE DATE LISTED ON THIS SHEET.

## CONNECTION DETAILS

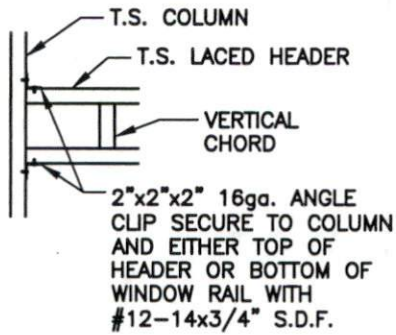

**1**  
COLUMN / LACED HEADER CONNECTION DETAIL

S14

SCALE: 1/2" = 1'-0"

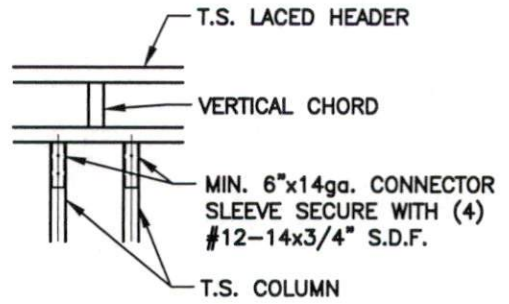

**2**  
LACED HEADER / COLUMN CONNECTION DETAIL

S14

SCALE: 1/2" = 1'-0"

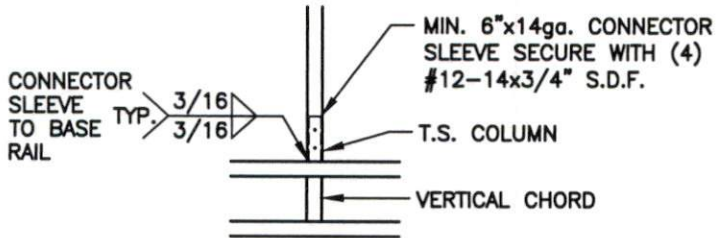

**3**  
COLUMN / LACED HEADER CONNECTION DETAIL

S14

SCALE: 1/2" = 1'-0"



**TAYLOR & VIOLA**  
STRUCTURAL ENGINEERS  
P.O.B. 2616 HICKORY NORTH CAROLINA  
TELE: 828-328-4331 FAX: 828-322-1801  
WWW.TAYLORVIOLA.COM

JCMT Associates, PLLC  
211 Stone Drive, Pilot Mountain, NC 27041  
Telephone: (336) 399-6277

**NC CARPORTS & GARAGES**

116 EAST MARKET STREET  
ELKIN, NORTH CAROLINA 28621  
TELE: 336-368-0668

DRAWN BY:  
BKS

PROJECT NO:  
MISC

DATE:  
01.23.24

SHEET NO:  
**S14**

NOTE: THESE DRAWINGS ARE VALID FOR (1) CALENDAR YEAR AFTER THE ISSUE DATE LISTED ON THIS SHEET.

BOX EVE RAFTER LEAN-TO OPTIONS

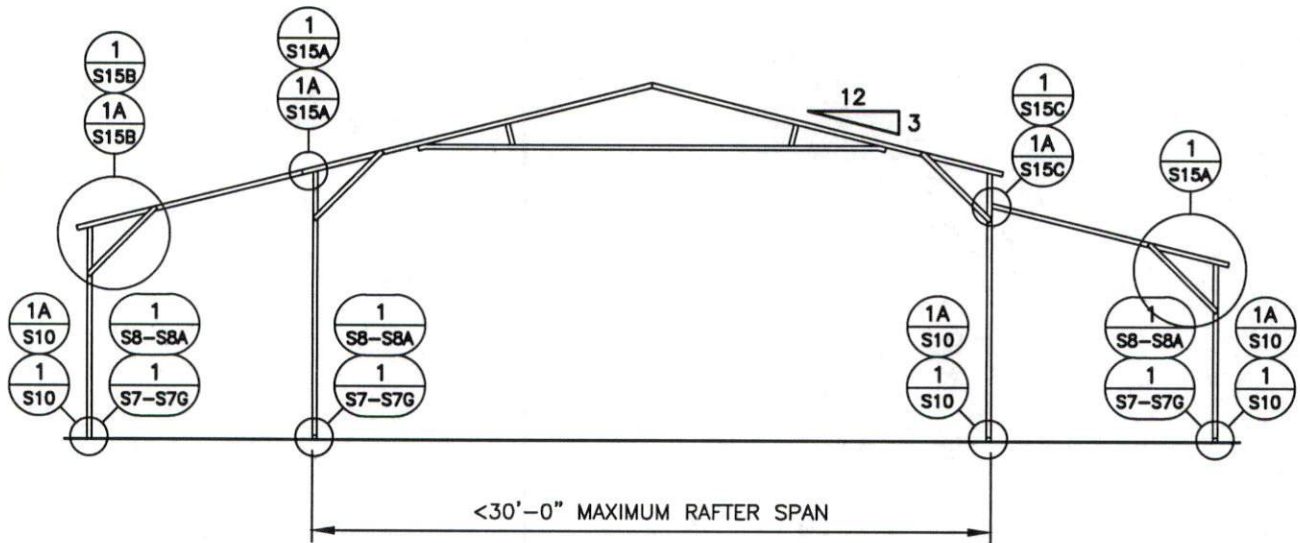

TYPICAL LEAN-TO OPTIONS FRAMING SECTION (BOTH OPTIONS SHOWN)

MAXIMUM WIDTH OF SINGLE MEMBER ROOF EXTENSION AND LEAN-TO OPTION IS 12'-0"

MAXIMUM WIDTH OF DOUBLE MEMBER ROOF EXTENSION AND LEAN-TO IS 15'-0"

12'-0" MAX. LEAN-TO HEIGHT WITH SINGLE COLUMN

16'-0" MAX. LEAN-TO HEIGHT WITH DOUBLE COLUMN



**TAYLOR & VIOLA**  
STRUCTURAL ENGINEERS  
P.O.B. 2616 HICKORY NORTH CAROLINA  
TELE: 828-328-6931 FAX: 828-322-1901  
WWW.TAYLORVIOLA.COM

**JCMT Associates, PLLC**  
211 Stone Drive, Pilot Mountain, NC 27041  
Telephone: (336) 399-6277

**NC CARPORTS  
& GARAGES**

116 EAST MARKET STREET  
ELKIN, NORTH CAROLINA 28621  
TELE: 336-368-0668

**DRAWN BY:**  
BKS

**PROJECT NO:**  
MISC

**DATE:**  
01.23.24

**SHEET NO:**  
**S15**

NOTE: THESE DRAWINGS ARE VALID FOR (1) CALENDAR YEAR AFTER THE ISSUE DATE LISTED ON THIS SHEET.

LEAN-TO CONNECTION DETAILS

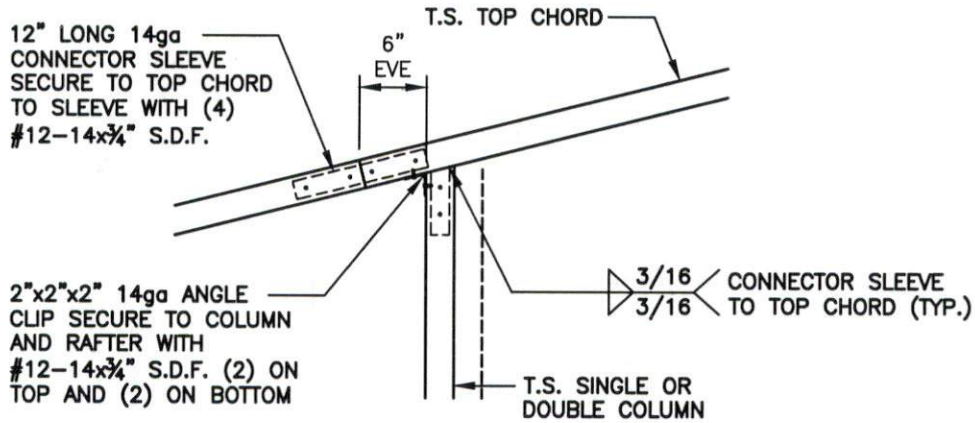

ROOF EXTENSION RAFTER / CORNER POST  
DETAIL FOR WIDTHS < 12'-0"

1  
S15A

SCALE: 3/4" = 1'-0"

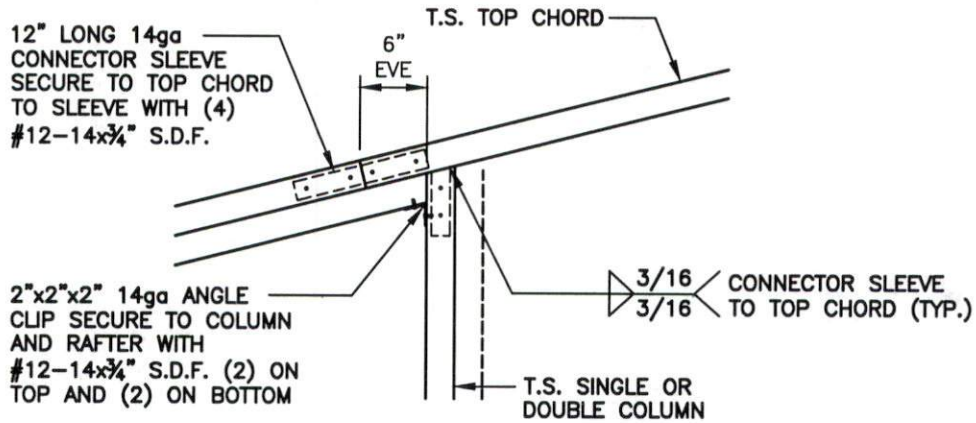

ROOF EXTENSION RAFTER / CORNER POST  
DETAIL FOR WIDTHS < 15'-0"

1A  
S15A

SCALE: 3/4" = 1'-0"



**TAYLOR & VIOLA**  
STRUCTURAL ENGINEERS  
P.O.B. 2616 HICKORY NORTH CAROLINA  
TELE: 828-326-6331 FAX: 828-322-1801  
WWW.TAYLORVIOLA.COM

JCMT Associates, PLLC  
211 Stone Drive, Pilot Mountain, NC 27041  
Telephone: (336) 399-6277

**NC CARPORTS  
& GARAGES**

116 EAST MARKET STREET  
ELKIN, NORTH CAROLINA 28621  
TELE: 336-368-0668

DRAWN BY:  
BKS

PROJECT NO:  
MISC

DATE:  
01.23.24

SHEET NO:  
**S15A**



## LEAN-TO CONNECTION DETAILS - SINGLE COLUMN

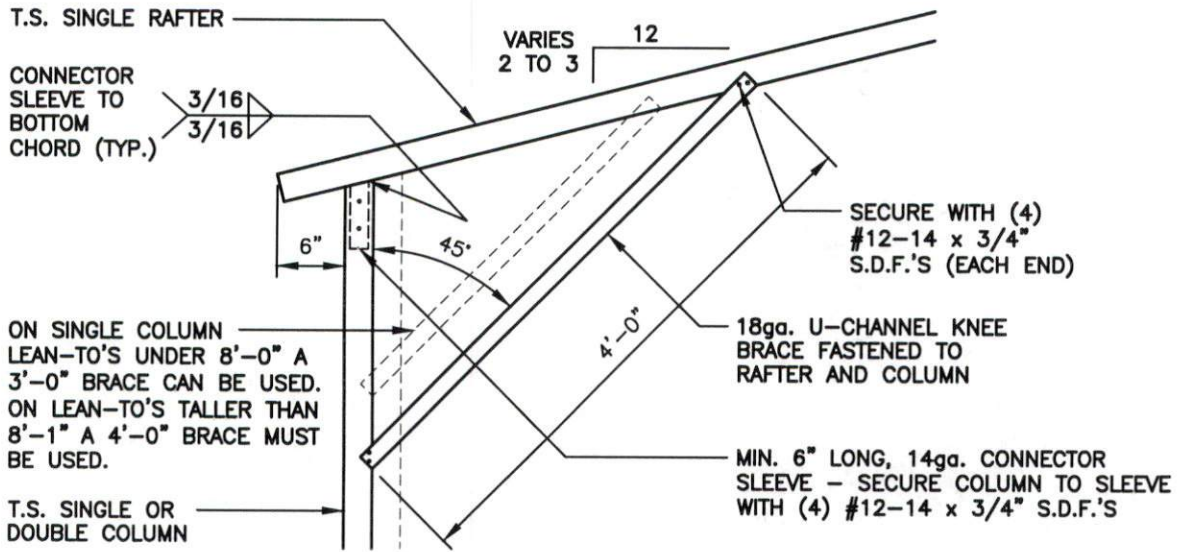

### LEAN-TO SINGLE RAFTER / SINGLE COLUMN CONNECTION DETAIL

1  
S15B

SCALE: 3/4" = 1'-0"

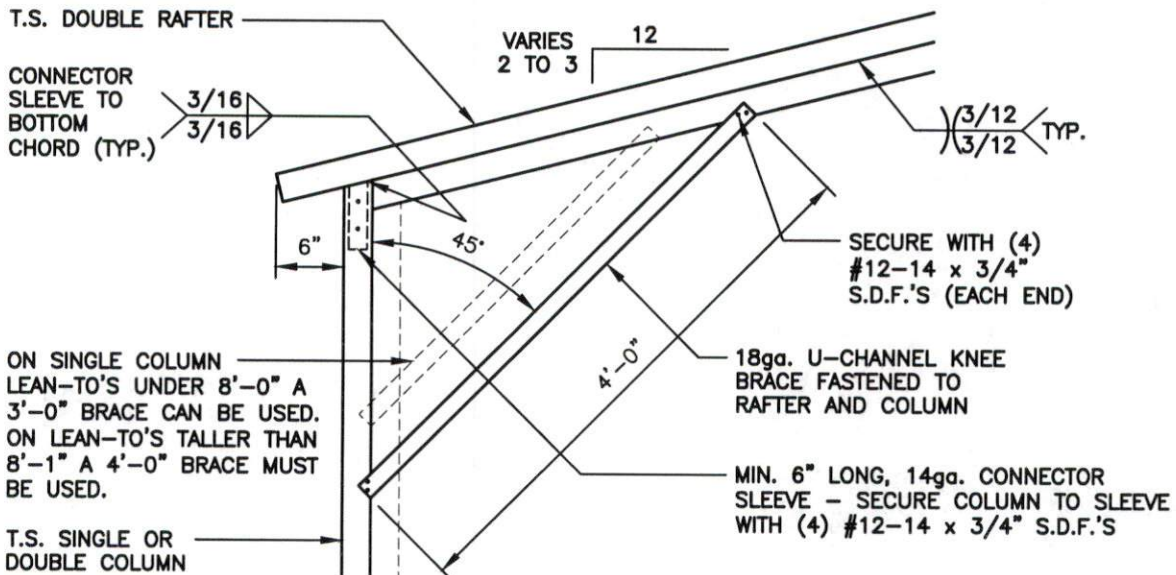

### LEAN-TO DOUBLE RAFTER / SINGLE COLUMN CONNECTION DETAIL

1A  
S15B

SCALE: 3/4" = 1'-0"

**Taylor & Viola**  
STRUCTURAL ENGINEERS  
P.O.B. 2616 HICKORY NORTH CAROLINA  
TELE: 828-398-6331 FAX: 828-322-1991  
WWW.TAYLORVIOLA.COM

JCMT Associates, PLLC  
211 Stone Drive, Pilot Mountain, NC 27041  
Telephone: (336) 399-6277

NC CARPORTS  
& GARAGES

116 EAST MARKET STREET  
ELKIN, NORTH CAROLINA 28621  
TELE: 336-368-0668

DRAWN BY:  
BKS

PROJECT NO:  
MISC

DATE:  
01.23.24

SHEET NO:  
**S15B**

NOTE: THESE DRAWINGS ARE VALID FOR (1) CALENDAR YEAR AFTER THE ISSUE DATE LISTED ON THIS SHEET.

LEAN-TO / MAIN FRAME CONNECTION DETAILS

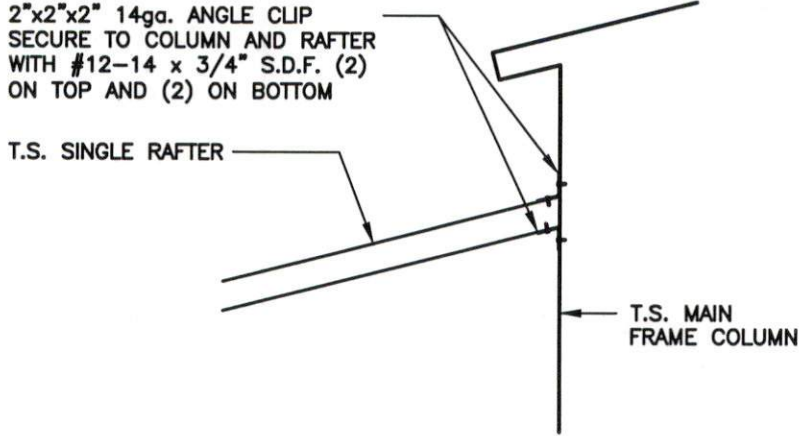

LEAN-TO SINGLE RAFTER / BUILDING FRAME CONNECTION DETAIL

1  
S15C

SCALE: 3/4" = 1'-0"

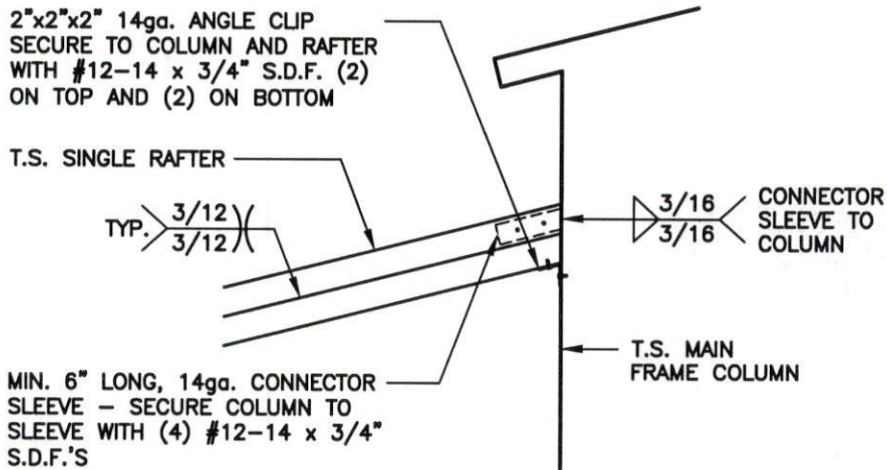

LEAN-TO DOUBLE RAFTER / BUILDING FRAME CONNECTION DETAIL

1A  
S15C

SCALE: 3/4" = 1'-0"

**Taylor & Viola**  
STRUCTURAL ENGINEERS  
P.O.B. 2616 HICKORY NORTH CAROLINA  
TELE: 828-326-6931 FAX: 828-322-1901  
WWW.TAYLORVIOLA.COM

**JCMT Associates, PLLC**  
211 Stone Drive, Pilot Mountain, NC 27041  
Telephone: (336) 399-6277

**NC CARPORTS & GARAGES**

116 EAST MARKET STREET  
ELKIN, NORTH CAROLINA 28621  
TELE: 336-368-0668

**DRAWN BY:**  
BKS

**PROJECT NO:**  
MISC

**DATE:**  
01.23.24

**SHEET NO:**  
**S15C**

NOTE: THESE DRAWINGS ARE VALID FOR (1) CALENDAR YEAR AFTER THE ISSUE DATE LISTED ON THIS SHEET.

VERTICAL ROOF / SIDING OPTION

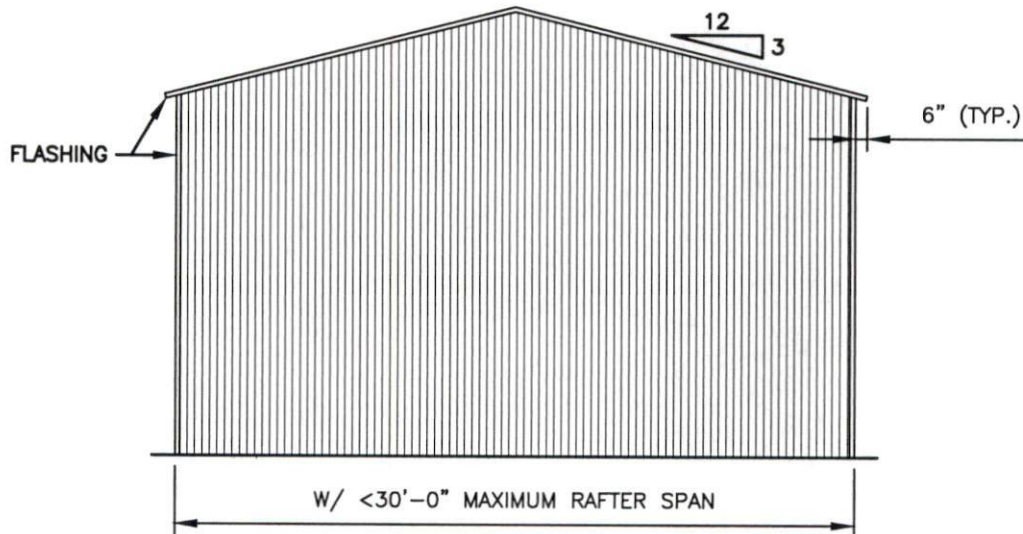

TYPICAL END ELEVATION - VERTICAL ROOF / SIDING

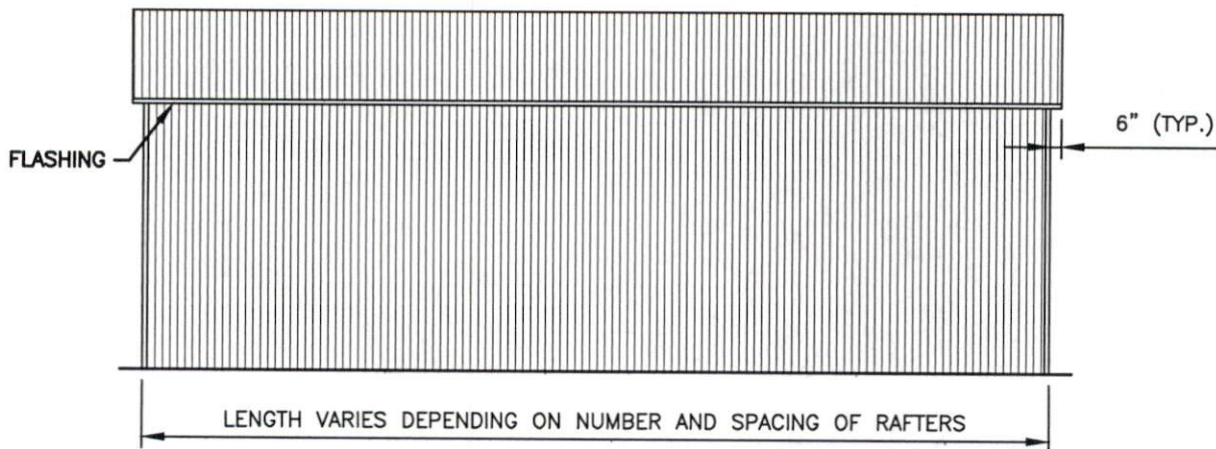

TYPICAL SIDE ELEVATION - VERTICAL ROOF / SIDING



TAYLOR & VIOLA  
STRUCTURAL ENGINEERS  
P.O.B. 2616 HICKORY NORTH CAROLINA  
TELE: 828-328-6331 FAX: 828-322-1801  
WWW.TAYLORVIOLA.COM

JCMT Associates, PLLC  
211 Stone Drive, Pilot Mountain, NC 27041  
Telephone: (336) 399-6277

NC CARPORTS  
& GARAGES

116 EAST MARKET STREET  
ELKIN, NORTH CAROLINA 28621  
TELE: 336-368-0668

DRAWN BY:  
BKS

PROJECT NO:  
MISC

DATE:  
01.23.24

SHEET NO:  
**S16**

NOTE: THESE DRAWINGS ARE VALID FOR (1) CALENDAR YEAR AFTER THE ISSUE DATE LISTED ON THIS SHEET.

VERTICAL ROOF / SIDING OPTION

1.125"-18ga. HAT CHANNELS  
FASTENED TO EACH RAFTER  
WITH (2) #12-14x $\frac{3}{4}$ " S.D.F.  
SPACED AT 4'-0"oc MAX.

29ga. GALVANIZED METAL  
ROOF AND WALL PANELS  
FASTENED TO HAT  
CHANNELS AND GIRT.S.

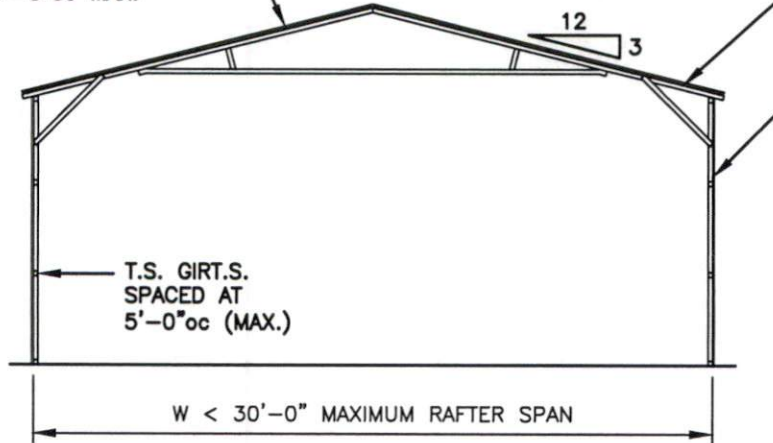

TYPICAL SECTION VERTICAL ROOF / SIDING OPTION

NOTE:  
H.S.S. 2-1/2"x2-1/2"x14ga. OR  
2-1/4"x2-1/4"x14ga. MATERIAL  
MAY BE USED FOR TRUSS METAL.

**TAYLOR & VIOLA**  
STRUCTURAL ENGINEERS  
P.O.B. 2616 HICKORY NORTH CAROLINA  
TELE: 828-328-6931 FAX: 828-322-1901  
WWW: TAYLORVIOLA.COM  
**JCMT Associates, PLLC**  
211 Stone Drive, Pilot Mountain, NC 27041  
Telephone: (336) 399-6277

**NC CARPORTS  
& GARAGES**  
116 EAST MARKET STREET  
ELKIN, NORTH CAROLINA 28621  
TELE: 336-368-0668

DRAWN BY:  
BKS

PROJECT NO:  
MISC

DATE:  
01.23.24

SHEET NO:  
**S16A**

NOTE: THESE DRAWINGS ARE VALID FOR (1) CALENDAR YEAR AFTER THE ISSUE DATE LISTED ON THIS SHEET.

VERTICAL ROOF / SIDING OPTION

SEE NOTES  
(SHEET S3)  
FOR MAXIMUM  
SPACING

1.125"-18ga. HAT CHANNELS  
FASTENED TO EACH RAFTER  
WITH (2) #12-14x $\frac{3}{4}$ " S.D.F.  
SPACED AT 4'-0"oc MAX.

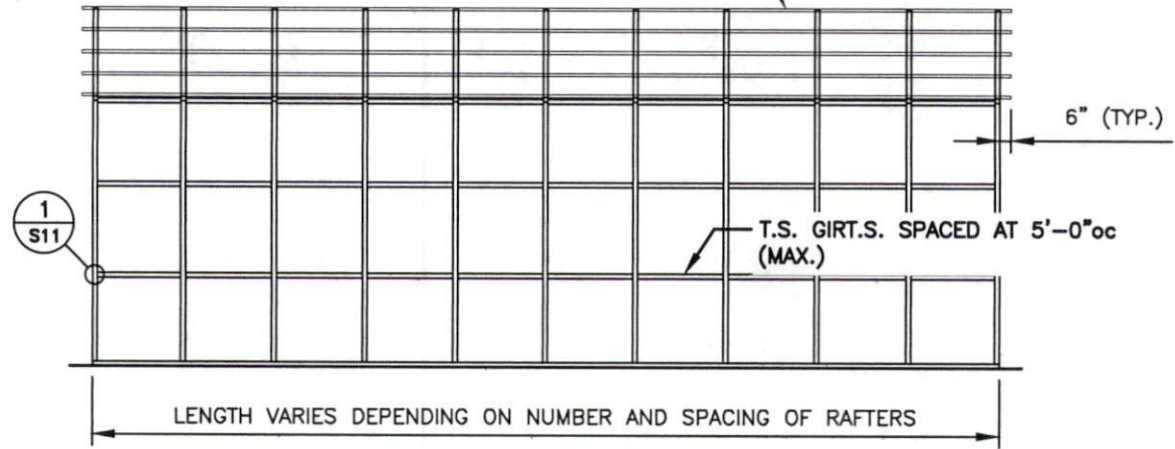

TYPICAL SIDE FRAMING SECTION VERTICAL ROOF / SIDING OPTION

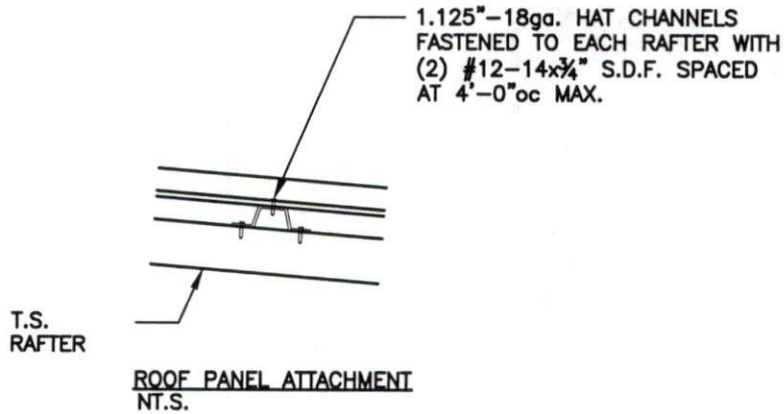

**TAYLOR & VIOLA**  
STRUCTURAL ENGINEERS  
P.O.B. 2616 HICKORY NORTH CAROLINA  
TELE: 828-328-4831 FAX: 828-322-1801  
WWW.TAYLORVIOLA.COM

JCMT Associates, PLLC  
211 Stone Drive, Pilot Mountain, NC 27041  
Telephone: (336) 399-6277

NC CARPORTS  
& GARAGES

116 EAST MARKET STREET  
ELKIN, NORTH CAROLINA 28621  
TELE: 336-368-0668

DRAWN BY:  
BKS

PROJECT NO:  
MISC

DATE:  
01.23.24

SHEET NO:  
**S168**

NOTE: THESE DRAWINGS ARE VALID FOR (1) CALENDAR YEAR AFTER THE ISSUE DATE LISTED ON THIS SHEET.

SIDE WALL HEADER OPTIONS

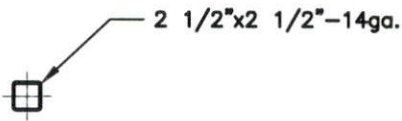

HEADER DETAIL FOR DOOR  
OPENINGS < 4'-0"  
 NT.S.

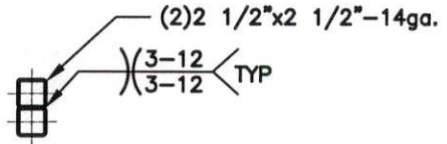

HEADER DETAIL FOR DOOR  
OPENINGS 4'-1" < TO < 12'-0"  
 NT.S.

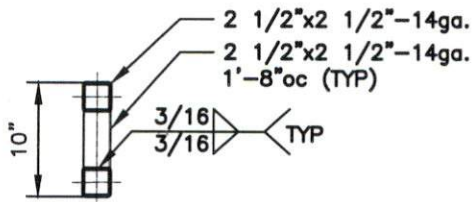

LACED HEADER DETAIL FOR DOOR  
OPENINGS 12'-1" < TO < 15'-0"  
 NT.S.

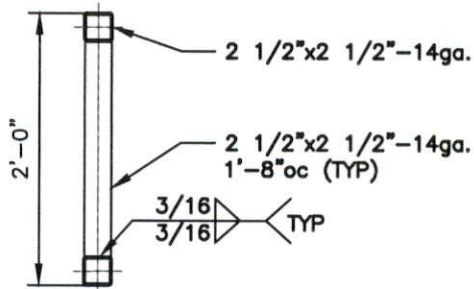

LACED HEADER DETAIL FOR DOOR  
OPENINGS 15'-1" < TO < 20'-0"

**Taylor & Viola**  
 STRUCTURAL ENGINEERS  
 P.O.B. 2616 HICKORY NORTH CAROLINA  
 TEL: 828-328-6331 FAX: 828-322-1801  
 WWW.TAYLORVIOLA.COM  
**JCMT Associates, PLLC**  
 211 Stone Drive, Pilot Mountain, NC 27041  
 Telephone: (336) 399-6277

**NC CARPORTS & GARAGES**  
 116 EAST MARKET STREET  
 ELKIN, NORTH CAROLINA 28621  
 TELE: 336-368-0668

**DRAWN BY:**  
 BKS

**PROJECT NO:**  
 MISC

**DATE:**  
 01.23.24

**SHEET NO:**  
**S17**

NOTE: THESE DRAWINGS ARE VALID FOR (1) CALENDAR YEAR AFTER THE ISSUE DATE LISTED ON THIS SHEET.

END WALL HEADER OPTIONS

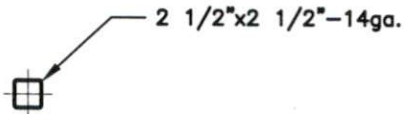

HEADER DETAIL FOR DOOR  
OPENINGS < 7'-0"  
 NT.S.

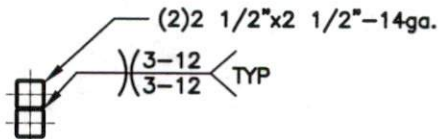

HEADER DETAIL FOR DOOR  
OPENINGS 7'-1" < TO < 16'-0"  
 NT.S.

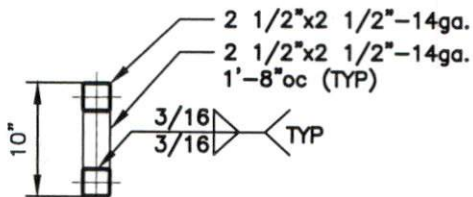

LACED HEADER DETAIL FOR DOOR  
OPENINGS 16'-1" < TO < 20'-0"  
 NT.S.



**TAYLOR & VIOLA**  
 STRUCTURAL ENGINEERS  
 P.O.B. 2616 HICKORY NORTH CAROLINA  
 TELE: 828-326-6331 FAX: 828-322-1801  
 WWW: TAYLORVIOLA.COM

JCMT Associates, PLLC  
 211 Stone Drive, Pilot Mountain, NC 27041  
 Telephone: (336) 399-6277

**NC CARPORTS**  
**& GARAGES**

116 EAST MARKET STREET  
 ELKIN, NORTH CAROLINA 28621  
 TELE: 336-368-0668

<b>DRAWN BY:</b> BKS	<b>PROJECT NO:</b> MISC
<b>DATE:</b> 01.23.24	<b>SHEET NO:</b> <b>S17A</b>

NOTE: THESE DRAWINGS ARE VALID FOR (1) CALENDAR YEAR AFTER THE ISSUE DATE LISTED ON THIS SHEET.

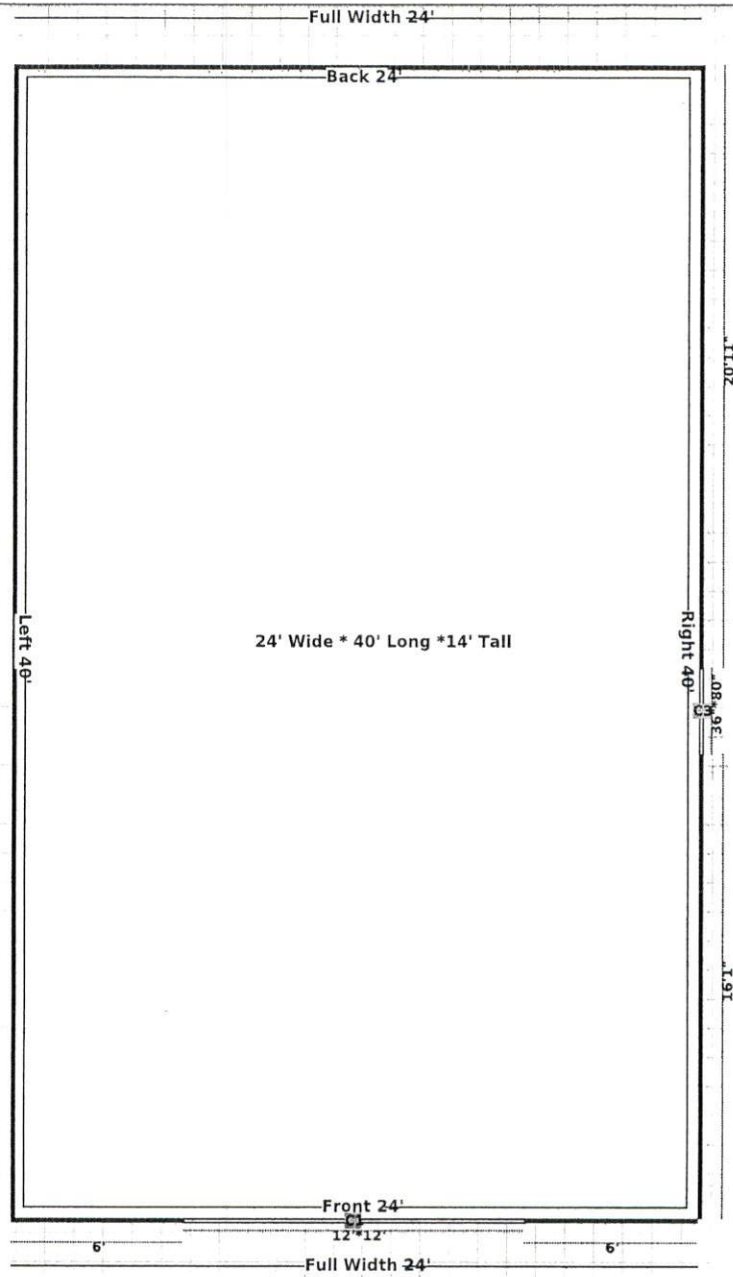

LEGENDS

- C1 Garage Door
- C2 Garage Door Frameout
- C3 Walk in Door
- C4 Walk in Door Frameout
- C5 Windows
- C6 Windows Frameout
- C7 Open Wall
- C8 Close Wall
- C9 Distance
- C10 Storage Length (Utility)
- C Cupola



BUILDING VIEW

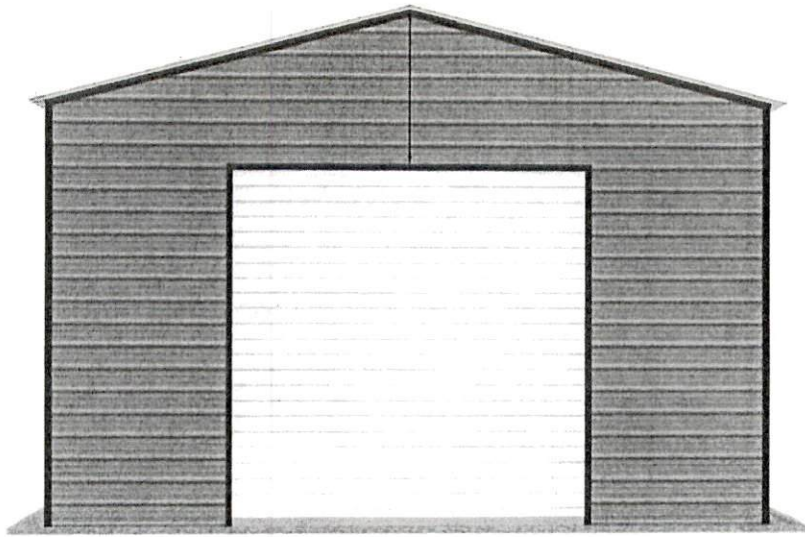

FRONT