



J&D SPRINKLER CO., INC.
Fire Protection - Est. 1986

**315 W Main St,
Clayton, NC 27520
(919) 553-2356**

WWW.JDSPRINKLER.COM

HARBOR FREIGHT

46 SHRIJI LN

ERWIN

NORTH CAROLINA

SUBMITTAL DATA



VALVES

FireLock® Butterfly Valve

Series 705 with Weatherproof Actuator



1.0 PRODUCT DESCRIPTION

- Available Sizes: 2 – 12”/50 – 300 mm
- cULus Listed, LPCB Listed, FM and VdS Approved for service up to 300 psi/2068 kPa /20 bar.
- Designed for fire protection services only.
- Features a weatherproof actuator housing Approved for indoor and outdoor use.
- Actuation options: Hand wheel (2 – 12”/50 – 300 mm)
- Exclusively for use with pipe and Victaulic products which feature ends formed with the Victaulic Original Groove System (OGS) groove profile (see section 7.0 for Reference Materials).

2.0 CERTIFICATION/LISTINGS



NOTES

- Refer to Victaulic [submittal publication 10.01](#) for details

ALWAYS REFER TO ANY NOTIFICATIONS AT THE END OF THIS DOCUMENT REGARDING PRODUCT INSTALLATION, MAINTENANCE OR SUPPORT.

System No.		Location	
Submitted By		Date	

Spec Section		Paragraph	
Approved		Date	

2.1 CERTIFICATION/LISTINGS

Size	Approval/Listing Service Pressures			
	Series 705 Butterfly Valve			
	cULus	FM	Vds	LPCB
2 50	up to 300psi/2068kPa	n/a	up to 300psi/2068kPa	up to 300psi/2068kPa
2½ 65	up to 300psi/2068kPa	up to 300psi/2068kPa	n/a	up to 300psi/2068kPa
76.1 mm	up to 300psi/2068kPa	up to 300psi/2068kPa	up to 300psi/2068kPa	up to 300psi/2068kPa
3 80	up to 300psi/2068kPa	up to 300psi/2068kPa	up to 300psi/2068kPa	up to 300psi/2068kPa
4 100	up to 300psi/2068kPa	up to 300psi/2068kPa	up to 300psi/2068kPa	up to 300psi/2068kPa
5 125	up to 300psi/2068kPa	up to 300psi/2068kPa	n/a	up to 300psi/2068kPa
139.7 mm	up to 300psi/2068kPa	up to 300psi/2068kPa	up to 300psi/2068kPa	up to 300psi/2068kPa
6 150	up to 300psi/2068kPa	up to 300psi/2068kPa	up to 300psi/2068kPa	up to 300psi/2068kPa
165.1 mm	up to 300psi/2068kPa	up to 300psi/2068kPa	n/a	up to 300psi/2068kPa
8 200	up to 300psi/2068kPa	up to 300psi/2068kPa	up to 300psi/2068kPa	up to 300psi/2068kPa
10 250	up to 300psi/2068kPa	up to 300psi/2068kPa	n/a	up to 300psi/2068kPa
12 300	up to 300psi/2068kPa	up to 300psi/2068kPa	n/a	up to 300psi/2068kPa

3.0 SPECIFICATIONS – MATERIAL

Body: Ductile Iron conforming to ASTM A-536, Grade 65-45-12

End Face, 2 – 6”/50 – 150 mm: Ductile Iron conforming to ASTM A-536, Grade 65-45-12

Seal Retainer, 8 – 12”/200 – 300 mm: Ductile Iron conforming to ASTM A-536, Grade 65-45-12

Body Coating: Black alkyd enamel

Disc: Ductile Iron conforming to ASTM A-536, Grade 65-45-12, with electroless nickel coating conforming to ASTM B-733

Seat: Grade “E” EPDM

Stems: 416 stainless steel conforming to ASTM A-582

Stem Seal Cartridge: C36000 brass

Bearings: Stainless steel with TFE lining

Stem Seals: EPDM

Stem Retaining Ring: Carbon steel

Actuator:

2 – 8”/50 – 200 mm: Brass or bronze traveling nut on a steel lead screw, in a ductile iron housing

10 – 12”/250 – 300 mm: Steel worm and cast iron quadrant gear, in a cast iron housing

4.0 DIMENSIONS

Series 705

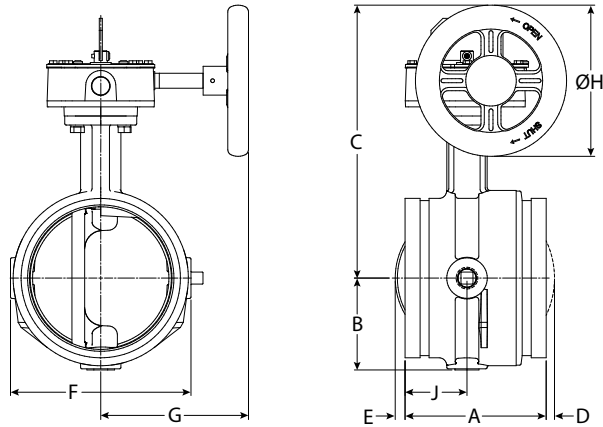

Size		Dimensions								
Nominal inches mm	Actual Outside Diameter inches mm	E to E A inches mm	B inches mm	C inches mm	D inches mm	E inches mm	F inches mm	G inches mm	DIA H inches mm	J inches mm
2 60.3	2.375 60.3	4.25 108.0	2.28 57.9	6.41 162.8	-	-	4.00 101.6	4.22 107.2	4.50 114.3	2.12 53.8
2½ 73	2.875 73.0	3.77 95.8	2.28 57.9	7.54 191.5	-	-	4.00 101.6	4.22 107.2	4.50 114.3	1.77 45.0
76.1 mm	3.000 76.1	3.77 95.8	2.28 57.9	7.54 191.5	-	-	4.00 101.6	4.22 107.2	4.50 114.3	1.77 45.0
3 88.9	3.500 88.9	3.77 95.8	2.53 64.3	7.79 197.9	-	-	4.50 114.3	4.22 107.2	4.50 114.3	1.77 45.0
108 mm	4.250 108.0	4.63 117.6	2.88 73.2	8.81 223.8	-	-	5.50 139.7	4.22 107.2	4.50 114.3	2.20 55.9
4 114.3	4.500 114.3	4.63 117.6	2.88 73.2	8.81 223.8	-	-	5.50 139.7	4.22 107.2	4.50 114.3	2.20 55.9
133 mm	5.250 133.0	5.88 149.4	3.35 85.1	10.88 276.4	-	-	6.56 166.6	6.19 157.2	6.30 160.0	2.58 65.5
139.7 mm	5.500 139.7	5.88 149.4	3.35 85.1	10.88 276.4	-	-	6.56 166.6	6.19 157.2	6.30 160.0	2.58 65.6
5 141.3	5.563 141.3	5.88 149.4	3.35 85.1	10.88 276.4	-	-	6.56 166.6	6.19 157.2	6.30 160.0	2.58 65.5
159 mm	6.250 159.0	5.88 149.4	3.84 97.5	11.38 289.1	-	0.41 10.4	7.52 191.0	6.19 157.2	6.30 160.0	2.58 65.5
165.1 mm	6.500 165.1	5.88 149.4	3.84 97.5	11.38 289.1	-	0.41 10.4	7.52 191.0	6.19 157.2	6.30 160.0	2.58 65.5
6 168.3	6.625 168.3	5.88 149.4	3.84 97.5	11.38 289.1	-	0.41 10.4	7.52 191.0	6.19 157.2	6.30 160.0	1.90 48.3
8 219.1	8.625 219.1	5.33 135.4	5.07 128.8	13.53 343.6	0.80 20.3	1.47 37.3	10.00 254.0	6.19 157.2	8.10 205.7	2.33 59.2
10 273	10.750 273.0	6.40 162.6	6.37 161.8	15.64 397.3	1.41 35.8	1.81 46.0	12.25 311.2	8.10 205.7	9.00 228.6	-
12 323.9	12.750 323.9	6.50 165.1	7.36 186.9	16.64 422.7	2.30 58.4	2.80 71.1	14.25 362.0	8.10 205.7	9.00 228.6	-

NOTE

- Optional ½"/15 mm tap available. Contact Victaulic for details.

5.0 PERFORMANCE

Series 705

The chart expresses the frictional resistance of Victaulic Series 705 Butterfly Valve in equivalent feet/meters of straight pipe.

Nominal Size mm inches	Outside Diameter mm inches	Equivalent
		Feet/m of pipe
2 50	2.375 60.3	6 1.8
2½ 65	2.875 73.0	6 1.8
76.1 mm	3.000 76.1	6 1.8
3 80	3.500 88.9	7 2.1
4 100	4.500 114.3	8 2.4
108 mm	108 mm	8 2.4
5 125	5.563 141.3	12 3.7
133 mm	133 mm	12 3.7
139.7 mm	5.500 139.7	12 3.7
6 150	6.625 168.3	14 4.2
159 mm	159 mm	14 4.3
165.1 mm	6.500 165.1	14 4.2
8 200	8.625 219.1	16 4.9
10 250	10.750 273.0	18 5.5
12 300	12.750 323.9	19 5.8

5.1 PERFORMANCE

Series 705

C_v values for flow of water at +60°F/+16°C through a fully open valve are shown in the table below. For additional details, contact Victaulic.

Formulas for C_v values

$$\Delta P = \frac{Q^2}{C_v^2}$$

$$Q = C_v \times \sqrt{\Delta P}$$

Where:

Q = Flow (GPM)
 ΔP = Pressure Drop (psi)
 C_v = Flow Coefficient

Formulas for K_v values

$$\Delta P = \frac{Q^2}{K_v^2}$$

$$Q = K_v \times \sqrt{\Delta P}$$

Where:

Q = Flow (m³/hr)
 ΔP = Pressure Drop (Bar)
 K_v = Flow Coefficient

Valve Size		Full Open
Nominal Size inches mm	Actual Outside Diameter inches mm	Flow Coefficient C _v
2 50	2.375 60.3	170
2½ 65	2.875 73.0	260
76.1 mm	3.000 76.1	260
3 80	3.500 88.9	440
4 100	4.500 114.3	820
108 mm	108 mm	820
5 125	5.563 141.3	1200
133 mm	133 mm	1200
139.7 mm	5.500 139.7	1200
6 150	6.625 168.3	1800
159 mm	159 mm	1800
165.1 mm	6.500 165.1	1800
8 200	8.625 219.1	3400
10 250	10.750 273.0	5800
12 300	12.750 323.9	9000

Valve Size		Full Open
Nominal Size inches mm	Actual Outside Diameter inches mm	Flow Coefficient K _v
2 50	2.375 60.3	147
2½ 65	2.875 73.0	225
76.1 mm	3.000 76.1	225
3 80	3.500 88.9	380
4 100	4.500 114.3	710
108 mm	108 mm	710
5 125	5.563 141.3	1040
133 mm	133 mm	1040
139.7 mm	5.500 139.7	1040
6 150	6.625 168.3	1560
159 mm	159 mm	1560
165.1 mm	6.500 165.1	1560
8 200	8.625 219.1	2940
10 250	10.750 273.0	5020
12 300	12.750 323.9	7790

6.0 NOTIFICATIONS

WARNING



- Read and understand all instructions before attempting to install, remove, adjust, or maintain any Victaulic piping products.
- Depressurize and drain the piping system before attempting to install, remove, adjust, or maintain any Victaulic piping products.
- Wear safety glasses, hardhat, and foot protection.

Failure to follow these instructions could result in death or serious personal injury and property damage.

7.0 REFERENCE MATERIALS

Switch and Wiring

1. The supervisory switch contains two single pole, double throw, pre-wired switches.
2. Switches are rated:
 - 10 amps @ 125 or 250 VAC/60 Hz
 - 0.50 amps @ 125 VDC
 - 0.25 amps @ 250 VDC
3. Switches supervise the valve in the “OPEN” position.
5. One switch has two #18 insulated wires per terminal, which permit complete supervision of leads (refer to diagrams and notes below). The second switch has one #18 insulated wire per terminal. This double circuit provides flexibility to operate two electrical devices at separate locations, such as an indicating light and an audible alarm, in the area that the valve is installed.
6. A #14 insulated ground lead (green) is provided.

Switch #1 = S1

For connection to the supervisory circuit of a UL Listed alarm control panel

Switch #2 = S2

Auxiliary switch that may be connected to auxiliary devices, per the authority having jurisdiction

S1 { Normally Closed: (2) Blue
Common: (2) Yellow

S2 { Normally Closed: Blue with Orange Stripe
Normally Open: Brown with Orange Stripe
Common: Yellow with Orange Stripe

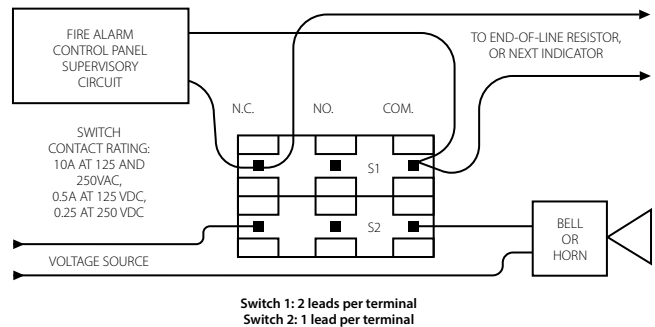
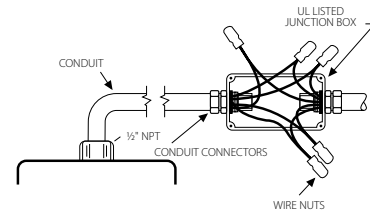

NOTES

- The above diagram shows a connection between the common terminal (yellow – S1 and yellow-with-orange stripe – S2) and the normally closed terminal (blue – S1 and blue-with-orange stripe – S2). In this example, the indicator light and alarm will stay on until the valve is fully open. When the valve is fully open, the indicator light and alarm will go out. Cap off any unused wires (e.g. brown with orange stripe).
- Only S1 (two leads per terminal) may be connected to the fire alarm control panel.
- The connection of the alarm switch wiring shall be in accordance with NFPA 72 and the auxiliary switch per NFPA 70 (NEC).

7.1 REFERENCE MATERIALS

[10.01: Regulatory Approval Reference Guide](#)

[29.01: Terms and Conditions/Warranty](#)

[I-100: Field Installation Handbook](#)

User Responsibility for Product Selection and Suitability

Each user bears final responsibility for making a determination as to the suitability of Victaulic products for a particular end-use application, in accordance with industry standards and project specifications, and the applicable building codes and related regulations as well as Victaulic performance, maintenance, safety, and warning instructions. Nothing in this or any other document, nor any verbal recommendation, advice, or opinion from any Victaulic employee, shall be deemed to alter, vary, supersede, or waive any provision of Victaulic Company's standard conditions of sale, installation guide, or this disclaimer.

Intellectual Property Rights

No statement contained herein concerning a possible or suggested use of any material, product, service, or design is intended, or should be construed, to grant any license under any patent or other intellectual property right of Victaulic or any of its subsidiaries or affiliates covering such use or design, or as a recommendation for the use of such material, product, service, or design in the infringement of any patent or other intellectual property right. The terms "Patented" or "Patent Pending" refer to design or utility patents or patent applications for articles and/or methods of use in the United States and/or other countries.

Note

This product shall be manufactured by Victaulic or to Victaulic specifications. All products to be installed in accordance with current Victaulic installation/assembly instructions. Victaulic reserves the right to change product specifications, designs and standard equipment without notice and without incurring obligations.

Installation

Reference should always be made to the Victaulic installation handbook or installation instructions of the product you are installing. Handbooks are included with each shipment of Victaulic products, providing complete installation and assembly data, and are available in PDF format on our website at www.victaulic.com.

Warranty

Refer to the Warranty section of the current Price List or contact Victaulic for details.

Trademarks

Victaulic and all other Victaulic marks are the trademarks or registered trademarks of Victaulic Company, and/or its affiliated entities, in the U.S. and/or other countries.



TECHNICAL DATA

EASY RISER® SWING CHECK VALVE MODELS E-1 & F-1

The Viking Corporation, 210 N Industrial Park Drive, Hastings MI 49058

Telephone: 269-945-9501 Technical Services: 877-384-5464 Fax: 269-818-1680 Email: techsvcs@vikingcorp.com
Visit the Viking website for the latest edition of this technical data page: www.vikinggroupinc.com

1. DESCRIPTION

The Viking Easy Riser® Swing Check Valve is a general purpose rubber-faced check valve approved for use in fire service systems. The valve is for use in wet system risers, preaction system risers and wherever a check valve with a drain connection and gauge connections can be utilized. When used with a flow switch on wet pipe systems not requiring a mechanical alarm, the Easy Riser® Swing Check Valve may replace an alarm check valve.

1-A Features

1. Ductile iron body for less weight and extra strength.
2. Rated to 300 psi (20.7 bar) water working pressure.
3. Rubber-faced clapper hinged to access cover for quick removal and easy servicing. All moving parts can be serviced without removing the valve from the installed position.
4. With the cover/clapper assembly removed, clapper rubber replacement requires removal of only one screw.
5. Valve housing tapped for inlet and outlet pressure gauges, and system main drain.

1-B Accessories

300 PSI (20.7 bar) Trim Package including:

- A. All necessary nipples and fittings
- B. Main Drain Ball Valve
- C. Necessary gauges



2. LISTINGS AND APPROVALS:

cULus Listed: HMER

FM Approved: Single Check Valves

NYC Department of Buildings: MEA 89-92-E, Vol. XI

VNIPO (250 psi (17.2 bar) MWP)

CE: Pressure Equipment Directive 97/23/EC (250 psi (17.2 bar) MWP)

3. TECHNICAL DATA

Specifications:

Standard Flanged Connections: ANSI B16.42 Class 150 (mates with ANSI Class 125 and Class 150 flanges).

Standard Grooved Connections: ANSI/AWWA C606

Drain outlet: 2-1/2" and 3" valves - one 1-1/4" (32 mm) NPT; 4", 6" & 8" valves - 2" (50 mm) NPT

Gauge Outlets: two 1/4" (8 mm) NPT

Other Outlets: two 1/2" (15 mm) NPT

Systems with water working pressures above 175 psi (12 bar) may require extra-heavy pattern fittings. Viking Easy Riser® Swing Check Valve flanges are Ductile Iron ANSI B16.42, Class 150, with a maximum water working pressure of 300 psi (20.7 bar). ANSI B16.42, Class 150 flanges are NOT compatible with ANSI Class 250 or Class 300 flanges. To mate the Easy Riser® Swing Check Valve with ANSI Class 250 or Class 300 flanges, use the grooved-inlet/grooved-outlet style installed with listed grooved/flanged adapters of the appropriate pressure rating. For piping with grooved connections, the grooved-inlet and/or grooved-outlet style Easy Riser® Swing Check Valve may be installed with listed grooved couplings of the appropriate pressure rating.

Material Standards:

Refer to Figure 1.

Ordering Information:

See Table 1 for part numbers and shipping weights.



TECHNICAL DATA

EASY RISER® SWING CHECK VALVE MODELS E-1 & F-1

The Viking Corporation, 210 N Industrial Park Drive, Hastings MI 49058

Telephone: 269-945-9501 Technical Services: 877-384-5464 Fax: 269-818-1680 Email: techsvcs@vikingcorp.com
Visit the Viking website for the latest edition of this technical data page: www.vikinggroupinc.com

4. INSTALLATION

The Easy Riser® Swing Check Valve must be installed in an area not subject to freezing temperatures or physical damage. When corrosive atmospheres and/or contaminated water supplies are present, it is the owner's responsibility to verify compatibility with the Easy Riser® Swing Check Valve, trim, and associated equipment.

Prior to installing the valve, thoroughly flush the water supply piping to verify that no foreign matter is present.

The Easy Riser® Swing Check Valve may be installed in the vertical position with direction of flow up, or in the horizontal position with the access cover up.

1. Remove all plastic thread protectors from the openings of the Easy Riser® Swing Check Valve.
2. Apply a small amount of pipe-joint compound or tape to the external threads of all pipe connections required. Take care not to allow any compound, tape, or other foreign matter inside any of the nipples or openings of the valve or trim components.
3. Easy Riser® Swing Check Valve Trim Charts are provided with Trim Packages and on the Viking website.
4. Verify that all system components are rated for the water working pressure of the system.

Hydrostatic Test:

The Easy Riser® Swing Check Valve is manufactured and listed for use at a maximum water working pressure of 300 psi (20.7 bar). The valve is factory tested at 600 psi (41.4 bar). Easy Riser® Swing Check Valves may be hydrostatically tested at 350 psi (24.1 bar) and/or 50 psi (3.5 bar) above the normal water working pressure for limited periods of time (two hours) for the purpose of acceptance by the Authority Having Jurisdiction. If air testing is required, DO NOT exceed 40 psi (2.8 bar) air pressure.

5. OPERATION (Refer to Figure 1.)

Water flowing through the Viking Easy Riser® Swing Check Valve lifts the rubber-gasketed clapper (8 and 9) off the seat (12) and flows into the sprinkler piping. When flow through the valve stops, the clapper (8) closes quickly. The rubber gasket (9) forms a tight seal against the brass water seat (12), trapping pressurized water above the clapper and preventing reverse flow from the sprinkler piping.

6. INSPECTIONS, TESTS, AND MAINTENANCE

NOTICE

The owner is responsible for maintaining the fire protection system and devices in proper operating condition.

The Viking Easy Riser® Swing Check Valve and trim must be kept free of foreign matter, freezing conditions, corrosive atmospheres, contaminated water supplies, and any condition that could impair its operation or damage the device.

It is imperative that the system be inspected and tested on a regular basis. The frequency of the inspections may vary due to contaminated water supplies, corrosive water supplies, and corrosive atmospheres. For minimum maintenance and inspection requirements, refer to NFPA 25. In addition, the Authority Having Jurisdiction may have additional maintenance, testing, and inspection requirements that must be followed.

WARNING

Any system maintenance that involves placing a control valve or detection system out of service may eliminate the fire protection capabilities of that system. Prior to proceeding, notify all Authorities Having Jurisdiction. Consideration should be given to employment of a fire patrol in the affected areas.

6-A. Five-Year Internal Inspection

Internal inspection of check valves is recommended every five years unless inspections and tests indicate more frequent inspections are required. (Refer to Figure 1.)

1. Notify the Authority Having Jurisdiction, remote station alarm monitors, and those in the area affected that the system will be taken out of service. Consideration should be given to employment of a fire patrol in the affected areas.
2. Close the water supply main control valve, placing the system out of service.
3. Open the main drain. If necessary, open the system test valve to vent and completely drain the system.
4. Use the appropriate wrench to loosen and remove cover screws (14), and remove cover and clapper assembly (2-11).
5. Inspect water seat (12). Wipe away all contaminants, dirt, and mineral deposits. DO NOT use solvents or abrasives.
6. Inspect cover and clapper assembly (2-11) and cover gasket (13). Test the hinged clapper (8) for freedom of movement. Renew or replace damaged or worn parts as required.



TECHNICAL DATA

EASY RISER® SWING CHECK VALVE MODELS E-1 & F-1

The Viking Corporation, 210 N Industrial Park Drive, Hastings MI 49058

Telephone: 269-945-9501 Technical Services: 877-384-5464 Fax: 269-818-1680 Email: techsvcs@vikingcorp.com
Visit the Viking website for the latest edition of this technical data page: www.vikinggroupinc.com

⚠ CAUTION

NEVER apply any lubricant to seats, gaskets, or any internal operating parts of the valve. Petroleum-based grease or oil will damage rubber components and may prevent proper operation.

7. When internal inspection of the Easy Riser® Swing Check Valve is complete, perform step 6 of paragraph 11. MAINTENANCE to re-install cover and clapper assembly (2-11).

6-B. Maintenance (Refer to Figure 1.)

1. Perform steps 1 through 5 of paragraph 6-A, FIVE-YEAR INTERNAL INSPECTION.
2. To replace clapper assembly (3, 6-11):
 - a. Remove the cover screws (14) from the cover (2) using a Socket Wrench with a 9/16" socket.
 - b. Remove the cover and clapper assembly (2-11) from the valve.
 - c. Remove the cover gasket (13) by sliding it over the clapper assembly.
 - d. Remove the existing clapper assembly (3, 6-11) from the cover assembly (2):
 - i. Remove one of the retaining rings (5) from the clapper hinge pin (4) using a flat head screwdriver.
 - ii. Remove the clapper hinge pin (4) from the cover and clapper assembly. This will allow the clapper assembly (3, 6-11) to be removed from the cover assembly (2).
 - e. Install the new clapper assembly (3, 6-11) onto the cover assembly (2):
 - i. Make sure the clapper rubber (9) is facing opposite the direction of the flow arrow on the inside of the cover (2).
 - ii. Line up the holes of the cover assembly (2) and the clapper assembly (3, 6-11) and insert the hinge pin (4).
 - iii. Install the retaining ring (5) onto the hinge pin (4).
 - iv. Install the cover gasket (13) onto the new cover and clapper assembly (2-11) by sliding the cover gasket (13) over the clapper assembly (3, 6-11) and lining up the holes with the cover (2).
 - v. To install the new cover and clapper assembly (2-11) into the valve, slide the clapper assembly into the valve with the clapper rubber (9) lined up with the water seat (12). Ensure the rubber retainer (10) fits inside the seat of the valve (pull back slightly and there should be some resistance).
 - vi. Line up the holes of the cover (2) and cover gasket (13) with the valve body (1) and replace the cover screws (14) using a Socket Wrench with a 9/16" socket.
3. To replace the clapper rubber (9):
 - i. Remove the cover screws (14) from the cover (2) using a Socket Wrench with a 9/16" socket.
 - ii. Remove the cover and clapper assembly (2-11) from the valve.
 - iii. Remove the cover gasket (13) by sliding it over the clapper assembly (3, 6-11).
 - iv. Use a 7/32" Allen wrench to hold the button head socket screw (11) in place and remove the jam nut (6) from the clapper rubber (9) using a Socket Wrench with a 9/16" socket.
 - v. Remove the button head socket screw (11) and sealing washer (7) from the clapper assembly (3, 6-11).
 - vi. Remove the clapper rubber retainer (10) from the clapper (8) to free the clapper rubber (9).
 - vii. To install the new clapper rubber (9), position the clapper rubber (9) on the clapper assembly so the grooved edge is facing down. This will allow the clapper rubber retainer (10) to fit up into the grooved edge of the clapper rubber (9).
 - viii. Install the button head socket screw (11) and sealing washer assembly (7) and the jam nut (6) using a 7/32" Allen wrench and a Socket Wrench with a 9/16" socket.
 - ix. Install the cover gasket (13) onto the cover (2) by sliding it over the clapper assembly (3, 6-11).
 - x. Re-install the cover and clapper assembly (2-11) back into the valve, with the clapper rubber (9) lined up with the water seat (12). Ensure the clapper rubber retainer (10) fits inside the seat of the valve (pull back slightly and there should be some resistance).
 - xi. Line up the holes of the cover (2) and cover gasket (13) with the valve body (1) and replace the cover screws (14) using a Socket Wrench with a 9/16" socket.
4. To replace the cover gasket (13):
 - i. Remove the cover screws (14) from the cover (2) using a Socket Wrench with a 9/16" socket.
 - ii. Remove the cover and clapper assembly (2-11) from the valve.
 - iii. Remove the cover gasket (13) by sliding it over the clapper assembly (3, 6-11).
 - iv. Install the new cover gasket (13) by sliding it over the clapper assembly (3, 6-11), onto the cover (2).
5. Reinstall the cover and clapper assembly (2-11) into the valve:
 - i. Line up the clapper rubber (9) with the water seat (12). Ensure the clapper rubber retainer (10) fits inside the seat of the valve (pull back slightly and there should be some resistance).
 - ii. Line up the holes of the cover (2) and cover gasket (13) with the valve body (1) and replace the cover screws (14) using a Socket Wrench with a 9/16" socket.



TECHNICAL DATA

EASY RISER® SWING CHECK VALVE MODELS E-1 & F-1

The Viking Corporation, 210 N Industrial Park Drive, Hastings MI 49058

Telephone: 269-945-9501 Technical Services: 877-384-5464 Fax: 269-818-1680 Email: techsvcs@vikingcorp.com
Visit the Viking website for the latest edition of this technical data page: www.vikinggroupinc.com

7. AVAILABILITY

The Viking Easy Riser® Swing Check Valve is available through a network of domestic and international distributors. See the Viking Corp. Web site for closest distributor or contact The Viking Corporation.

8. GUARANTEES

For details of warranty, refer to Viking's current list price schedule or contact Viking directly.

Table 1 - Valve Part Numbers and Specifications

Description	Nominal Size	Part Number	Friction Loss*	Shipping Weight
Flange/Flange				
Flange Drilling	Model F-1			
ANSI 3"	3"	08505	10 ft. (3.1 m)	35 lbs. (16 kg)
ANSI 4"	4"	08508	13 ft. (4.0 m)	44 lbs. (20 kg)
ANSI 6"	6"	08511	20 ft. (6.0 m)	75 lbs. (34 kg)
ANSI/Japan DN100	DN100	09039	13 ft. (4.0 m)	44 lbs. (20 kg)
ANSI/Japan DN150	DN150	09385	20 ft. (6.0 m)	75 lbs. (34 kg)
ANSI/Japan DN200	DN200	14023	23 ft. (7.0 m)	119 lbs. (54 kg)
PN10/16 DN80	DN80	08796	10 ft. (3.1 m)	35 lbs. (16 kg)
PN10/16 DN100	DN100	08797	13 ft. (4.0 m)	44 lbs. (20 kg)
PN10/16 DN150	DN150	08835	20 ft. (6.0 m)	75 lbs. (34 kg)
PN10 DN200	DN200	08836	23 ft. (7.0 m)	119 lbs. (54 kg)
PN16 DN200	DN200	12355	23 ft. (7.0 m)	119 lbs. (54 kg)
Flange/Groove				
Flange Drilling / Pipe O.D.	Model F-1			
ANSI / 89mm	3"	08506	10 ft. (3.1 m)	27 lbs. (12 kg)
ANSI / 114mm	4"	08509	13 ft. (4.0 m)	37 lbs. (17 kg)
ANSI / 168mm	6"	08512	20 ft. (6.0 m)	64 lbs. (29 kg)
ANSI / 219mm	8"	08515	23 ft. (7.0 m)	119 lbs. (54 kg)
PN10/16 / 89mm	DN80	12648	10 ft. (3.1 m)	27 lbs. (12 kg)
PN10/16 / 114mm	DN100	12649	13 ft. (4.0 m)	37 lbs. (17 kg)
PN10/16 / 165mm	DN150	12652	20 ft. (6.0 m)	64 lbs. (29 kg)
PN10/16 / 168mm	DN150	08512	20 ft. (6.0 m)	64 lbs. (29 kg)
PN10 / 219mm	DN200	12651	23 ft. (7.0 m)	119 lbs. (54 kg)
PN16 / 219mm	DN200	12650	23 ft. (7.0 m)	119 lbs. (54 kg)
Groove/Groove				
Pipe O.D.	Model E-1			
73mm	2½" / DN65	07929	6 ft. (1.8 m)	16 lbs. (7 kg)
76 mm	2½" / DN65	13516	6 ft. (1.8 m)	16 lbs. (7 kg)
	Model F-1			
89mm	3" / DN80	08507	10 ft. (3.1 m)	20 lbs. (9 kg)
114mm	4" / DN100	08510	13 ft. (4.0 m)	27 lbs. (12 kg)
165mm	DN150	12356	20 ft. (6.0 m)	51 lbs. (23 kg)
168mm	6" / DN150	08513	20 ft. (6.0 m)	51 lbs. (23 kg)
219mm	8" / DN200	08516	23 ft. (7.0 m)	106 lbs. (48 kg)

*Expressed in equivalent length of Schedule 40 pipe based on Hazen & Williams formula: C = 120.

Table 2 - Torque Values for Easy Riser Swing Check Valve Cover Screws

Valve Size	Screw Size	Torque Value
2-1/2" (DN65)	3/8"-16 H.H.C.	19 ft-lb (2.63 kg-m)
3" (DN80)	3/8"-16 H.H.C.	19 ft-lb (2.63 kg-m)
4" (DN100)	3/8"-16 H.H.C.	19 ft-lb (2.63 kg-m)
6" (DN150)	½"-13 H.H.C.	45 ft-lb (6.23 kg-m)
8" (DN200)	5/8"-11 H.H.C.	93 ft-lb (12.9 kg-m)

Table 3 - Trim Package Part Numbers

Valve Size	Part Number
Wet System Trim Packages	
2-1/2", 3" (DN65), (DN80)	07236
4", 6", 8", (DN100), (DN150), (DN200)	07237
Preaction System Trim Packages	
2-1/2", 3" (DN65)	13776
4", 6", 8", (DN80), (DN100), (DN150), (DN200)	13777



TECHNICAL DATA

EASY RISER® SWING CHECK VALVE MODELS E-1 & F-1

The Viking Corporation, 210 N Industrial Park Drive, Hastings MI 49058

Telephone: 269-945-9501 Technical Services: 877-384-5464 Fax: 269-818-1680 Email: techsvcs@vikingcorp.com
Visit the Viking website for the latest edition of this technical data page: www.vikinggroupinc.com

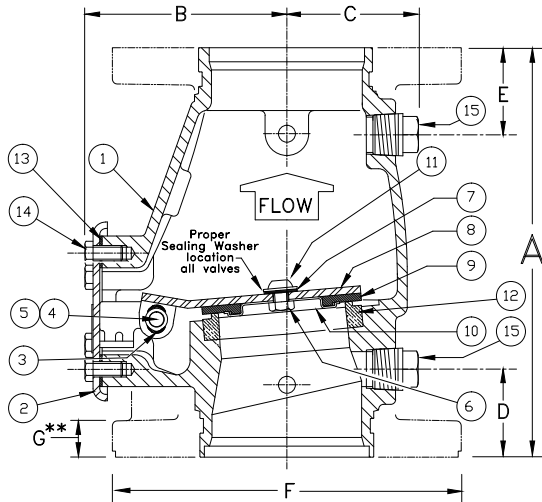

SIZE	A	B	C	D	E	F	G**
2-1/2" (65mm)	9" (228,6)	4-1/2" (114,3)	2-5/8" (66,7)	2" (50,8)	2" (50,8)	Flg-Flg Not Available	
3" (80mm)	10-1/8" (257)	4-13/16" (122,2)	2-11/16" (68,3)	2-9/32" (58,1)	2-9/32" (58,1)	7-7/8" (200)	25/32" (20)
4" (100mm)	10-5/8" (269,9)	5-3/16" (131,8)	3-1/8" (79,4)	2-1/4" (57,2)	2-1/4" (57,2)	9" (228,6)	15/16" (25,81)
6" (150mm)	13-3/8" (340)	6-13/16" (173,3)	4-1/16" (103,2)	2-1/4" (57,2)	2-1/4" (57,2)	11" (279,4)	1" (25,4)
8" (200mm)	17" (431,8)	8-13/16" (223,4)	5" (127)	2-1/2" (63,4)	2-7/8" (73,0)	13-1/2" (342,9)	1-1/8" (28,58)

Dimensions shown in parentheses are millimeter.

* For availability of Flg X Flg, Flg X Grv, or Grv X Grv options refer to Table 1.

** 4", 6", and 8" valves are manufactured with sculptured flanges. Dimension indicates thickness of flange at bolt holes.

Figure 1 - Replacement Parts

ITEM NO.	PART NUMBER					DESCRIPTION	MATERIAL	NO. REQ'D				
	E-1	F-1	F-1	F-1	F-1							
	2-1/2" (DN65)	3" (DN80)	4" (DN100)	6" (DN150)	8" (DN200)			2-1/2"	3"	4"	6"	8"
1	--	--	--	--	--	Body	Ductile Iron, ASTM A536 (65-45-12)	1	1	1	1	1
2	--	--	--	--	--	Cover Assembly	E-Coated HSLA Steel, A715 and Stainless Steel, UNS-S30400	1	1	1	1	1
3	07576	07576	07576	07576	None	Bushing	Lubricomp 189 Ryton	2	2	2	2	0
4	05355A	05355A	04900A	04991A	05334A	Clapper Hinge Pin	Stainless Steel, UNS-S30400	1	1	1	1	1
5	05445A	05445A	05445A	05445A	05369A	Hinge Pin Retaining Ring	Stainless Steel, UNS-S15700	2	2	2	2	2
6	01755A					Clapper Hex Jam Nut #10-24 UNC	Stainless Steel, UNS-S30400	1	0	0	0	0
		08159	08159			Clapper Hex Jam Nut 3/8"-24 UNF	Stainless Steel, UNS-S30400	0	1	1	0	0
				08144	08144	Clapper Hex Jam Nut 1/2"-20 UNF	Stainless Steel, UNS-S30400	0	0	0	1	1
7	--	08158	08158	08143	08143	Sealing Washer	EPDM and Stainless Steel	1	1	1	1	1
8	*	*	*	*	*	Clapper	PTFE Coated HR Steel UNS-G10180	1	1	1	1	1
9	*	*	*	*	*	Clapper Rubber	EPDM, ASTM D2000	1	1	1	1	1
10	*	*	*	*	*	Clapper Rubber Retainer	Stainless Steel, UNS-S30400	1	1	1	1	1
11	06595A					H.H.C. Screw, #10-24 UNC x 1/2" (12.7 mm) lg.	Stainless Steel, UNS-S30400	1	0	0	0	0
		10194	10194			Screw, Button Head, Socket, 3/8" - 24 UNF x 1/2 (12.7 mm) lg.	Stainless Steel, UNS-S30400	0	1	1	0	0
				10308		Screw, Button Head, Socket, 1/2" - 20 UNF x 3/4 (19.1 mm) lg.	Stainless Steel, UNS-S30400	0	0	0	1	0
					10686	Screw, Button Head, Socket, 1/2" - 20 UNF x 7/8 (22.2 mm) lg.	Stainless Steel, UNS-S30400	0	0	0	0	1
12	--	--	--	--	--	Seat	Brass, UNS-C84400	1	1	1	1	1
13	05354B	05354B	04649B	04992B	05339C	Cover Gasket	EPDM, ASTM D2000	1	1	1	1	1
14	01517A	01517A	01517A			Screw, Hex Head Cap, 3/8" - 16 UNC x 3/4 (19.1 mm) lg.	Steel, Zinc Plated	4	4	6	0	0
				04993A		Screw, Hex Head Cap, 1/2" - 13 x 7/8 (22.2 mm) lg.	Steel, Zinc Plated	0	0	0	6	0
					01922A	Screw, Hex Head Cap, 5/8" - 11 UNC x 1-1/4" (31.8 mm) lg.	Steel, Zinc Plated	0	0	0	0	6
15	--	--	--	--	--	1/2" (15 mm) NPT Pipe Plug	Steel	2	2	2	2	2

-- Indicates replacement part is not available

* Indicates replacement part only available in a Sub-Assembly listed below.

Sub-Assemblies

3, 6-11	05499B	08518	08519	08520	08521	Clapper Assembly
6, 7, 9, 11, 13	06343A	08522	08523	08524	08525	Replacement Rubber Kit



TECHNICAL DATA

EASY RISER® SWING CHECK VALVE MODELS E-1 & F-1

The Viking Corporation, 210 N Industrial Park Drive, Hastings MI 49058

Telephone: 269-945-9501 Technical Services: 877-384-5464 Fax: 269-818-1680 Email: techsvcs@vikingcorp.com
Visit the Viking website for the latest edition of this technical data page: www.vikinggroupinc.com

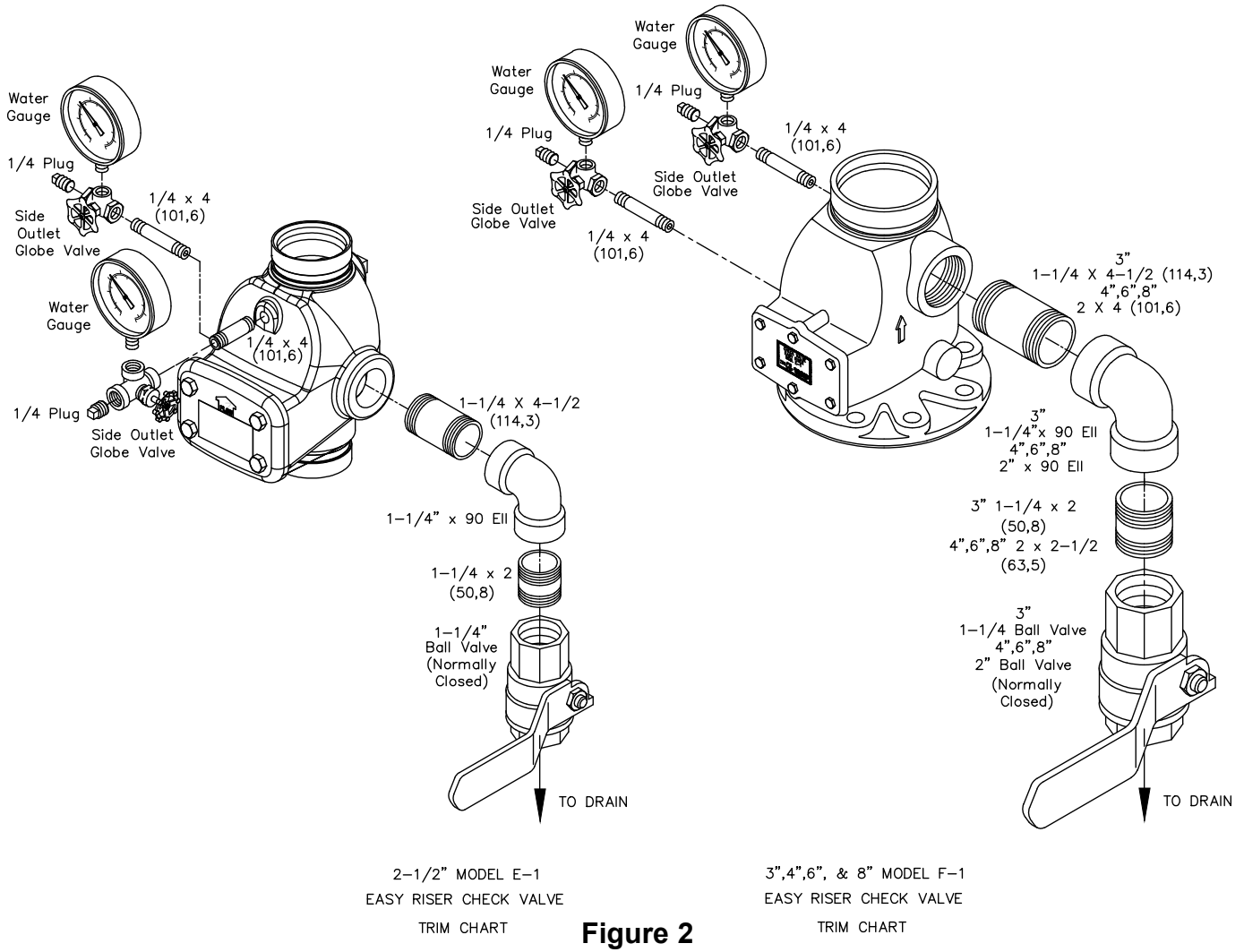

Note 1: 300 psi (20.7 bar) water pressure gauges are provided with trim. 600 psi (41.4 bar) water pressure gauges are available. Order separately when needed*. Refer to Viking's current price schedule.

* NFPA 13 requires gauges to have a minimum limit not less than twice the normal water working pressure at the point where the gauges are installed. When normal water working pressure exceeds 150 psi (10.3 bar), order 600 psi (41.4 bar) water pressure gauges separately.

Note 2: System Drain Ball Valve is UL Listed and FM Approved for 300 psi (20.7 bar) water working pressure.



TECHNICAL DATA

EASY RISER® SWING CHECK VALVE MODELS E-1 & F-1

The Viking Corporation, 210 N Industrial Park Drive, Hastings MI 49058

Telephone: 269-945-9501 Technical Services: 877-384-5464 Fax: 269-818-1680 Email: techsvcs@vikingcorp.com
Visit the Viking website for the latest edition of this technical data page: www.vikinggroupinc.com

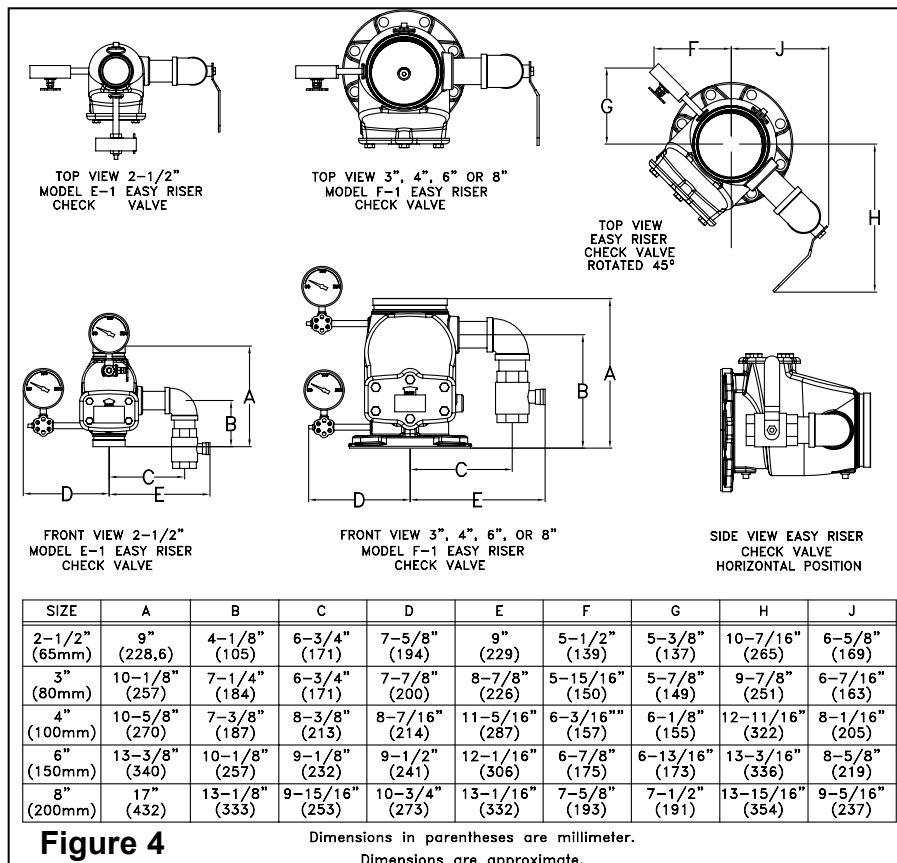
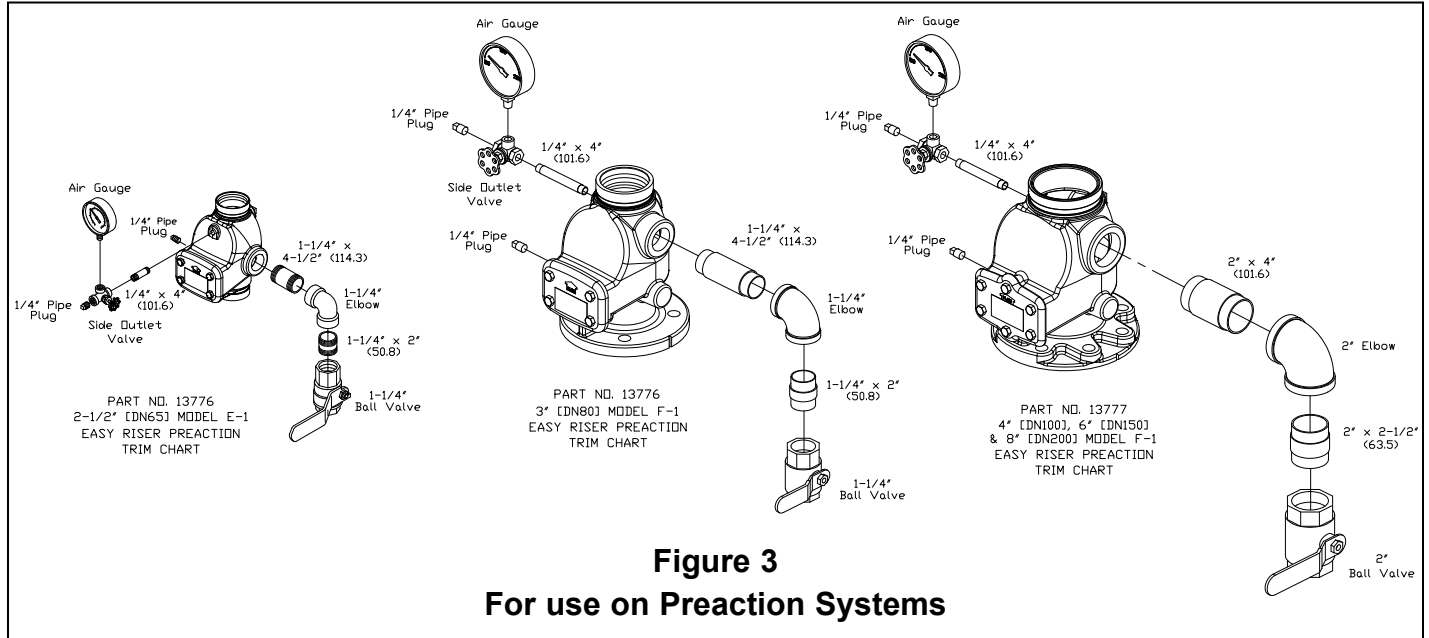

FireLock® Check Valves

Series 717 Check Valve

Series 717H High Pressure Check Valve



Series 717
(2½ – 3"/65 – 80 mm)



Series 717
(4 – 12"/100 – 300 mm)



Series 717H
High Pressure Check Valve
(2 – 3"/50 – 80 mm)

1.0 PRODUCT DESCRIPTION

Available Sizes

- 2 – 3"/DN50 – DN80 (Series 717H)
- 2½ – 12"/DN50 – DN300 (Series 717)

Pressure Class

- Up to 365 psi/2517 kPa/25 bar
- Working pressure dependent on size of pipe, valve size and approval requirements.

Application

- Designed for use in Fire Protection systems.
- Prevents back flow.
- Single-disc mechanism incorporates a spring-assisted feature for non-slamming operation.
- Can be installed either vertically (flow upwards only) or horizontally.
- Valve body cast with arrow indicator to assist with proper valve orientation.
- Optional upstream and downstream pressure taps included on select sizes. See Section 3.0.
- Provided with grooved ends.
- Rated for ambient temperature use in fire protection systems.

2.0 CERTIFICATION/LISTINGS



NOTE

- Refer to Victaulic [submittal publication 10.01](#) for details

ALWAYS REFER TO ANY NOTIFICATIONS AT THE END OF THIS DOCUMENT REGARDING PRODUCT INSTALLATION, MAINTENANCE OR SUPPORT.

System No.		Location	
Submitted By		Date	

Spec Section		Paragraph	
Approved		Date	

2.0 CERTIFICATION/LISTINGS (Continued)

Approvals/Listings

Size	Approval/Listing Service Pressures			
	Series 717H			
	cULus	FM	LPCB	Vds
2"/50 mm	365 psi/2517 kPa	365 psi/2517 kPa	365 psi/2517 kPa	365 psi/2517 kPa
2½"/65 mm	365 psi/2517 kPa	365 psi/2517 kPa	365 psi/2517 kPa	365 psi/2517 kPa
76.1 mm	365 psi/2517 kPa	365 psi/2517 kPa	365 psi/2517 kPa	365 psi/2517 kPa
3"/80 mm	365 psi/2517 kPa	365 psi/2517 kPa	365 psi/2517 kPa	365 psi/2517 kPa

Size	Approval/Listing Service Pressures			
	Series 717			
	cULus	FM	LPCB	Vds
2½"/65 mm	250 psi/1725 kPa	n/a	365 psi/2517 kPa	n/a
76.1 mm	250 psi/1725 kPa	n/a	365 psi/2517 kPa	16bar/232 psi
3"/80 mm	250 psi/1725 kPa	n/a	365 psi/2517 kPa	16bar/232 psi
4"/100 mm	365 psi/2517 kPa	365 psi/2517 kPa	365 psi/2517 kPa	16bar/232 psi
5"/125 mm	365 psi/2517 kPa	365 psi/2517 kPa	365 psi/2517 kPa	n/a
139.7 mm	365 psi/2517 kPa	365 psi/2517 kPa	365 psi/2517 kPa	16bar/232 psi
6"/150 mm	365 psi/2517 kPa	365 psi/2517 kPa	365 psi/2517 kPa	16bar/232 psi
165.1 mm	365 psi/2517 kPa	365 psi/2517 kPa	365 psi/2517 kPa	n/a
8"/200 mm	365 psi/2517 kPa	365 psi/2517 kPa	348 psi/2400 kPa	16bar/232 psi
10"/250 mm	250 psi/1725 kPa	250 psi/1725 kPa	1725 kPa/250 psi	n/a
12"/300 mm	250 psi/1725 kPa	250 psi/1725 kPa	1725 kPa/250 psi	n/a

3.0 SPECIFICATIONS – MATERIAL

Body:

Ductile Iron conforming to ASTM A-536, Grade 65-45-12.

Body Coating:

Series 717H Body: Black Paint

Series 717H Endface: Electroless Nickel conforming to ASTM B-733

Series 717 (2 ½ – 3"/DN65 – DN80): PPS Coating

Series 717 (4 – 12"/DN100 – DN300): Black Paint

Body Seat:

Series 717H: Nitrile O-ring installed into an Electroless Nickel plating conforming to ASTM B-733

Series 717 (2 ½" – 3"/DN65 – DN80): PPS Coated Ductile Iron

Series 717 (4 – 12"/DN100 – DN300): Ductile Iron with Electroless Nickel plating conforming to ASTM B-733

Disc Seal or Coating: (specify choice¹)

Nitrile (Series 717H only)

EPDM

NOT COMPATIBLE FOR PETROLEUM SERVICES.

Discs:

Series 717H: CF8M Cast Stainless Steel

Series 717 (2 ½ – 3"/DN65 – DN80): Aluminum bronze with elastomer seal

Series 717 (4 – 12"/DN100 – DN300): Elastomer encapsulated disc.

Shaft:

Series 717H: Brass

Series 717 (2 ½ – 3"/DN65 – DN80): Type 416 Stainless Steel

Series 717 (4 – 12"/DN100 – DN300): Type 316 Stainless Steel

Spring:

Type 302/304 Stainless Steel

Shaft Plug:

Series 717H: Carbon Steel Zinc Plated

Series 717: Carbon Steel Zinc Plated

Pipe Plug:

Series 717H: Carbon Steel Zinc Plated

Series 717: Carbon Steel Zinc Plated

Optional Pressure Taps:

Series 717H: Available on all sizes

Series 717: Available on sizes 4 – 12"/DN100 – DN300

4.0 DIMENSIONS

Series 717

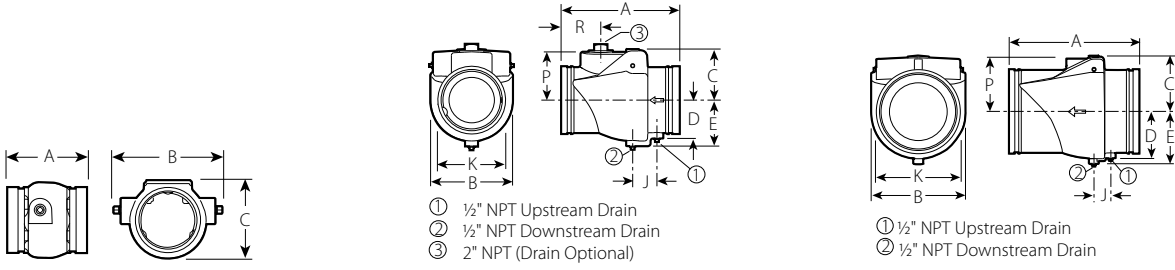

Typical 2 1/2 – 3/65 – 80 mm

Typical 4 – 8/100 – 200 mm

Typical 10 – 12/250 – 300 mm

Size		Dimensions									Weight
Nominal inches mm	Actual Outside Diameter inches mm	E to E A inches mm	B inches mm	C inches mm	D inches mm	E inches mm	J inches mm	K inches mm	P inches mm	R inches mm	Approximate (Each) lb kg
2 1/2 65	2.875 73.0	3.88 99	4.26 108	3.57 91	-	-	-	-	-	-	3.6 1.6
76.1 mm	3.000 76.1	3.88 99	4.26 108	3.57 91	-	-	-	-	-	-	3.6 1.6
3 80	3.500 88.9	4.25 108	5.06 129	4.17 106	-	-	-	-	-	-	4.5 2.0
4 100	4.500 114.3	9.63 245	6.00 152	3.88 99	2.75 70	3.50 89	2.00 51	4.50 114	3.50 89	3.35 85	20.0 9.1
5 125	5.563 141.3	10.50 267	6.80 173	4.50 114	-	4.17 106	2.15 55	5.88 149	4.08 104	3.98 101	27.0 12.3
139.7 mm	5.500 139.7	10.50 267	6.80 173	4.50 114	-	4.17 106	2.15 55	5.88 149	4.08 104	3.98 101	27.0 12.3
6 150	6.625 168.3	11.50 292	8.00 203	5.00 127	-	4.50 114	2.38 61	6.67 169	4.73 120	3.89 99	38.0 17.2
165.1 mm	6.500 165.1	11.50 292	8.00 203	5.00 127	-	4.50 114	2.38 61	6.67 169	4.73 120	3.89 99	38.0 17.2
8 200	8.625 219.1	14.00 356	9.88 251	6.06 154	5.05 128	5.65 144	2.15 55	8.85 225	5.65 144	5.75 146	64.0 29.0
10 250	10.750 273.0	17.00 432	12.00 305	7.09 180	5.96 151	6.69 170	2.15 55	10.92 277	6.73 171	-	100.0 45.4
12 300	12.750 323.9	19.50 495	14.00 356	8.06 205	6.91 176	7.64 194	2.51 64	12.81 925	7.73 196	-	140.0 63.5

4.1 DIMENSIONS

Series 717H

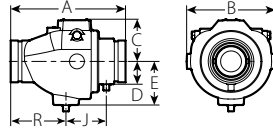

Typical 2¹/₅₀ mm – 3¹/₈₀ mm

Size	Dimensions									Weight
Nominal inches mm	E to E A inches mm	B inches mm	C inches mm	D inches mm	E inches mm	J inches mm	K inches mm	P inches mm	R inches mm	Approximate (Each) lb kg
2 50	8.66 219.8	6.46 164.1	3.23 82.1	1.48 37.5	3.02 76.7	2.80 71.0	-	-	4.25 108.0	10.7 4.9
2½ 65	9.37 238.0	6.94 176.3	3.31 84.1	1.66 42.2	3.40 86.4	3.38 85.9	-	-	4.38 111.3	13.8 6.3
76.1 mm	9.37 238.0	6.94 176.3	3.31 84.1	1.66 42.2	3.40 86.4	3.38 85.9	-	-	4.38 111.3	13.8 6.3
3 80	9.62 244.3	7.44 189.0	3.53 89.7	1.91 48.5	3.65 92.7	3.38 85.9	-	-	4.63 117.6	20.0 9.1

5.0 PERFORMANCE

Flow Characteristics

The charts below express the flow of water at 60°F/16°C through valve.

S717H / 717HR

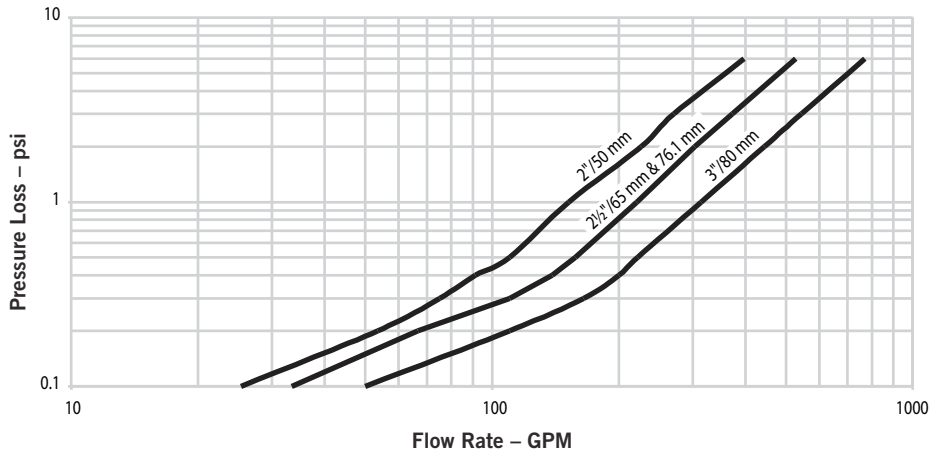

S717H / 717HR

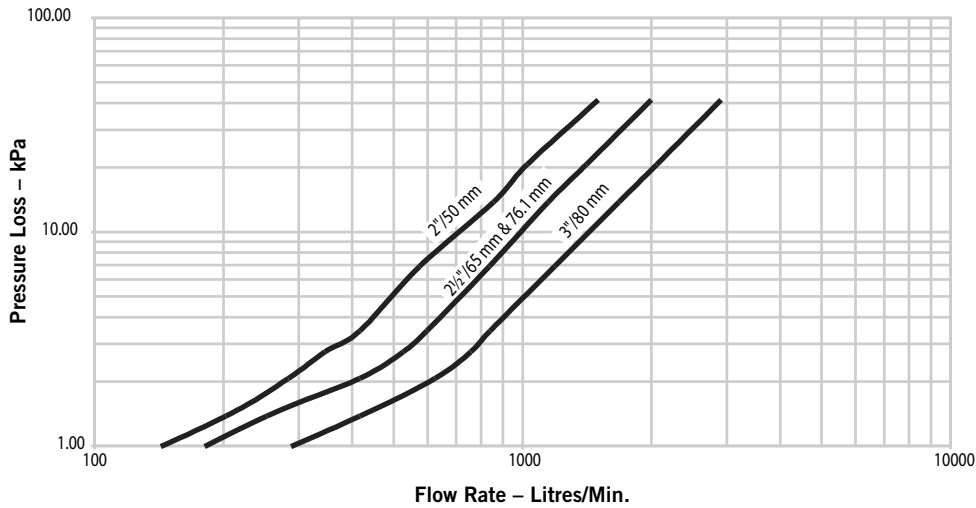

5.1 PERFORMANCE

Flow Characteristics

The charts below express the flow of water at 60°F/16°C through valve.

S717 / 717R

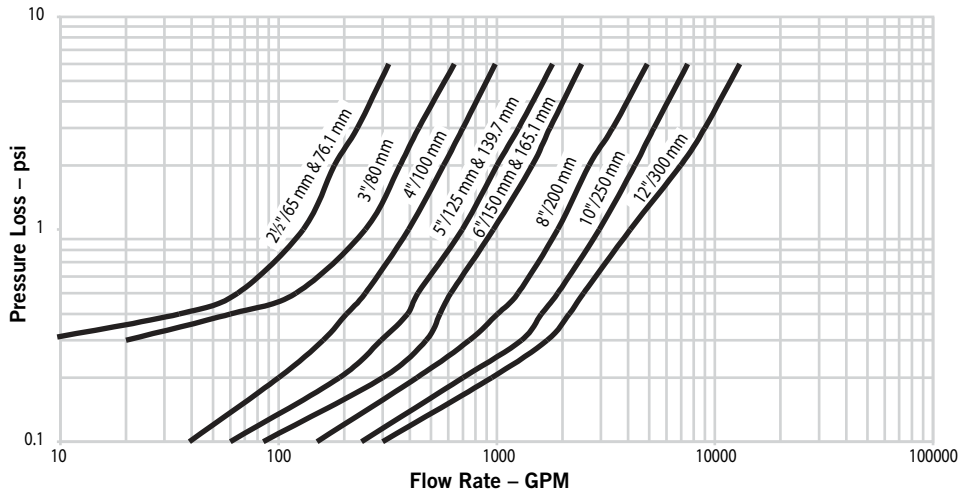

S717 / 717R

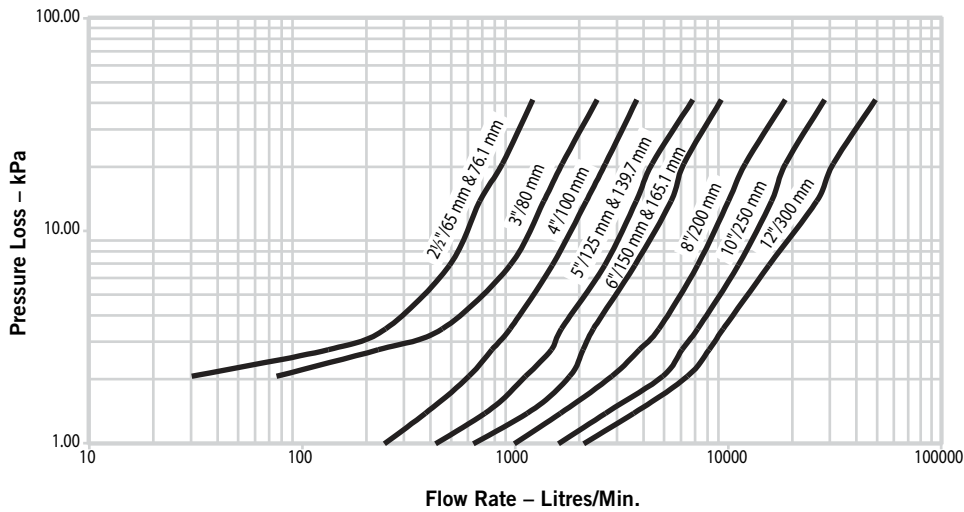

6.0 NOTIFICATIONS

WARNING

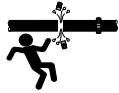

- Depressurize and drain the piping system before attempting to install, remove, adjust, or maintain any Victaulic piping products.

7.0 REFERENCE MATERIALS

[05.01: Seal Selection Guide](#)

[10.01: Regulatory Approval Reference Guide](#)

[29.01: Terms and Conditions/Warranty](#)

[I-100: Field Installation Handbook](#)

User Responsibility for Product Selection and Suitability

Each user bears final responsibility for making a determination as to the suitability of Victaulic products for a particular end-use application, in accordance with industry standards and project specifications, as well as Victaulic performance, maintenance, safety, and warning instructions. Nothing in this or any other document, nor any verbal recommendation, advice, or opinion from any Victaulic employee, shall be deemed to alter, vary, supersede, or waive any provision of Victaulic Company's standard conditions of sale, installation guide, or this disclaimer.

Intellectual Property Rights

No statement contained herein concerning a possible or suggested use of any material, product, service, or design is intended, or should be construed, to grant any license under any patent or other intellectual property right of Victaulic or any of its subsidiaries or affiliates covering such use or design, or as a recommendation for the use of such material, product, service, or design in the infringement of any patent or other intellectual property right. The terms "Patented" or "Patent Pending" refer to design or utility patents or patent applications for articles and/or methods of use in the United States and/or other countries.

Note

This product shall be manufactured by Victaulic or to Victaulic specifications. All products to be installed in accordance with current Victaulic installation/assembly instructions. Victaulic reserves the right to change product specifications, designs and standard equipment without notice and without incurring obligations.

Installation

Reference should always be made to the Victaulic installation handbook or installation instructions of the product you are installing. Handbooks are included with each shipment of Victaulic products, providing complete installation and assembly data, and are available in PDF format on our website at www.victaulic.com.

Warranty

Refer to the Warranty section of the current Price List or contact Victaulic for details.

Trademarks

Victaulic and all other Victaulic marks are the trademarks or registered trademarks of Victaulic Company, and/or its affiliated entities, in the U.S. and/or other countries.



Model 1011A TEST_{AND}DRAIN[®]

Sectional Floor Control Test and Drain Valve
for Systems Requiring Pressure Relief Valve

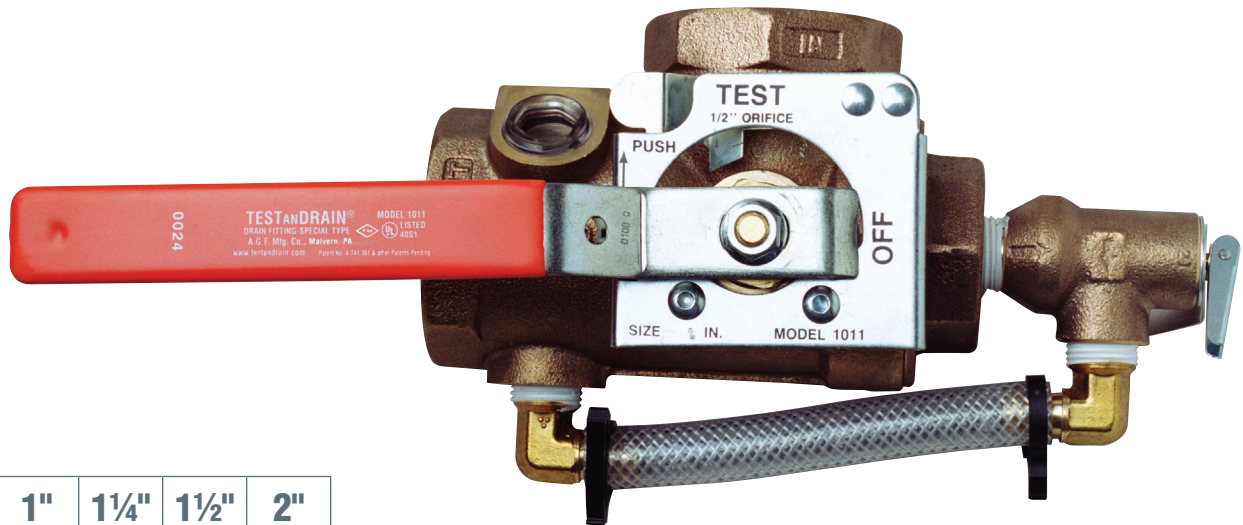

Sizes:

3/4"	1"	1 1/4"	1 1/2"	2"
------	----	--------	--------	----

The AGF **Model 1011A TEST_{AND}DRAIN[®]** provides the test and express drain functions for wet fire sprinkler systems on multi-story installations requiring pressure relief (NFPA 13 and NFPA 13R). The **Model 1011A** features a **Model 7000 Pressure Relief Valve** with drain pipe.

The **Model 1011A** is available in a full range of sizes (3/4" to 2") with NPT connections (BSPT available). The **Model 7000 Pressure Relief Valve** (UL/FM) features a flushing handle and a 175 PSI factory rating (other pressure ratings available).

- Complies with NFPA 13 and NFPA 13R Requirements
- Compact, Single-Handle Ball Valve
- Tamper-Resistant Test Orifice and Sight Glasses
- 300 PSI rated.
- Specifiable orifice sizes: 3/8" (2.8K), 7/16" (4.2K), 1/2" (5.6K), 17/32" (8.0K), 5/8" (11.2K, ELO), 3/4" (14.0K, ESFR), and K25
- Relieves Excess System Pressure caused by Surges or Temperature Changes
- Shipped with Relief Valve and Bypass Drain Ports Plugged to Expedite Pressure Testing
- Locking Kit Available

Repair kits are available for all **TEST_{AND}DRAIN[®]** valves. Kit includes: Adapter Gasket (1), Ball (1), Valve Seats (2), Stem Packing (1), and Stem Washer (1). *Valve and orifice size must be specified when ordering.*

NOTE: It is important to note that the pressure rating of the relief valve indicates an operating range of pressure for both opening and closing of the valve. Standard relief valves are required to OPEN in a range of pressure between 90% and 105% of their rating. The valves are required to CLOSE at a pressure above 80% of that rating. The relief valve should be installed where it is easily accessible for maintenance. Care should be taken that the relief valve CANNOT be isolated from the system when the system is operational. A relief valve should NEVER have a shutoff valve or a plug downstream of its outlet.

Reliability, Versatility, Code Compatibility



Model 1011A TEST AND DRAIN®

Model 1011A 300 PSI Bronze Ball Valve, Model 7000 Pressure Relief Valve
Factory Rated at 175 PSI with other setting available

Dimensions

SIZE	A	B	C	D	E	F	G	H
3/4"	7 9/16" (191 mm)	1 1/2" (37.5 mm)	2 3/16" (57 mm)	3 5/8" (93 mm)	3 3/8" (86 mm)	1 13/16" (46 mm)	4 9/16" (117 mm)	6 3/8" (162.5 mm)
1"	7 9/16" (191 mm)	1 1/2" (37.5 mm)	2 3/16" (57 mm)	3 5/8" (93 mm)	3 3/8" (86 mm)	1 13/16" (46 mm)	4 9/16" (117 mm)	6 3/8" (162.5 mm)
1 1/4"	7 15/16" (201 mm)	1 11/16" (43 mm)	2 9/16" (65 mm)	4 1/4" (108 mm)	3 5/8" (91 mm)	1 15/16" (51 mm)	5 9/16" (141 mm)	7 1/2" (192 mm)
1 1/2"	8 15/16" (227 mm)	1 13/16" (45 mm)	3 1/4" (81.5 mm)	5 1/16" (127 mm)	3 7/8" (99 mm)	2 5/8" (67 mm)	8 1/4" (207 mm)	10 7/8" (274 mm)
2"	8 15/16" (227 mm)	1 13/16" (45 mm)	3 1/4" (81.5 mm)	5 1/16" (127 mm)	3 7/8" (99 mm)	2 5/8" (67 mm)	8 1/4" (207 mm)	10 7/8" (274 mm)

The Model 1011A provides the following...

From the 2013 Edition of NFPA 13

- Chapter 8.16.2.4.1* Provisions shall be made to properly drain all parts of the system.
- Chapter 8.16.2.4.2 Drain connections, interior sectional or floor control valve(s) – & 8.16.2.4.3 shall be provided with a drain connection having a minimum size as shown in Table 8.16.2.4.2.
- Chapter 8.16.2.4.4 Drains shall discharge outside or to a drain capable of handling the flow of the drain.
- Chapter A.8.17.4.2 (Wet Pipe System) test connection is permitted to terminate into a drain capable of accepting full flow... using an approved sight test connection containing a smooth bore corrosion-resistant orifice giving a flow equivalent to one sprinkler...
- Chapter 8.17.4.2.2 The test connection valve shall be accessible.
- Chapter 8.17.4.2.4 shall be permitted to be installed in any location... downstream of the waterflow alarm.
- Chapter 8.17.4.3.1 (Dry Pipe System) a trip test connection not less than 1" in diameter, terminating in a smooth bore corrosion-resistant orifice, to provide a flow equivalent to one sprinkler...
- Chapter 8.17.4.3.2 The trip test connection... with a shutoff valve and plug not less than 1", at least one of which shall be brass.
- Chapter 7.1.2 - a wet pipe system shall be provided with a listed relief valve set to operate at 175 PSI or 10 PSI in excess of the maximum system pressure, whichever is greater.
- Chapter 8.16.1.2.3* A listed relief valve of not less than 1/2" in size shall be provided on the discharge side of the pressure-reducing valve set to operate at a pressure not exceeding rated pressure of the system.
- Chapter A.8.16.1.2.3 - consideration should be given to piping the discharge from the (pressure relief) valve

Model 1011A - Front View

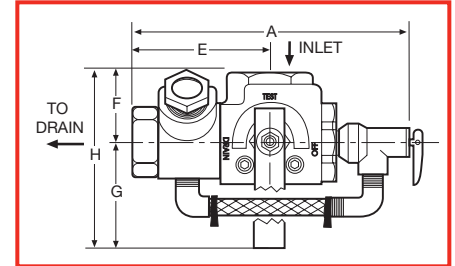

Model 1011A - Plan View

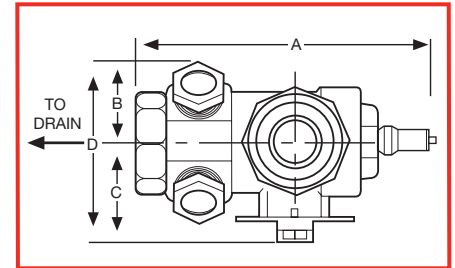

Orifice Sizes

3/8", 7/16", 1/2", 17/32", 5/8" ELO*,
3/4" ESRF*, and K25**

Materials

- Handle Steel
- Stem Rod Brass
- Ball C.P. Brass
- Body Bronze
- Valve Seat Impregnated Teflon®
- Indicator Plate Steel
- Relief Valve Bronze
- Bypass Fittings... Brass
- Bypass Tubing.... Nylobraid

Approvals

UL and ULC Listed:
(EX4019 & EX4533)
FM Approved
NYC-BSA No. 720-87-SM



USA Patent # 4741361 and Other Patents Pending



AGF Manufacturing Inc.
100 Quaker Lane, Malvern, PA 19355
Phone: 610-240-4900
Fax: 610-240-4906
www.testandrain.com

Job Name: _____
Architect: _____
Engineer: _____
Contractor: _____

*Available on 1 1/4" to 2" size units only • **Available on 1 1/2" and 2" size units only



Specifications subject to change without notice.

Ordering Information			
Nominal Pipe Size		Model	Part Number
2"	DN50	VSR-2	1144402
2 1/2"	DN65	VSR-2 1/2	1144425
3"	DN80	VSR-3	1144403
3 1/2"	-	VSR-3 1/2	1144435
4"	DN100	VSR-4	1144404
5"	-	VSR-5	1144405
6"	DN150	VSR-6	1144406
8"	DN200	VSR-8	1144408

Optional: Cover Tamper Switch Kit, stock no. 0090148

Replaceable Components: Retard/Switch Assembly, stock no. 1029030

UL, CUL and CSFM Listed, FM Approved, LPCB Approved, For CE Marked (EN12259-5) / VdS Approved model use VSR-EU

Service Pressure: 450 PSI (31 BAR) - UL

Flow Sensitivity Range for Signal:

4-10 GPM (15-38 LPM) - UL

Maximum Surge: 18 FPS (5.5 m/s)

Contact Ratings: Two sets of SPDT (Form C)

10.0 Amps at 125/250VAC

2.0 Amps at 30VDC Resistive

10 mAmps min. at 24VDC

Conduit Entrances: Two knockouts provided for 1/2" conduit.

Individual switch compartments suitable for dissimilar voltages.

Environmental Specifications:

- NEMA 4/IP54 Rated Enclosure suitable for indoor or outdoor use with factory installed gasket and die-cast housing when used with appropriate conduit fitting.
- Temperature Range: 40°F - 120°F, (4.5°C - 49°C) - UL
- Non-corrosive sleeve factory installed in saddle.

Service Use:

Automatic Sprinkler

NFPA-13

One or two family dwelling

NFPA-13D

Residential occupancy up to four stories

NFPA-13R

National Fire Alarm Code

NFPA-72

WARNING

- Installation must be performed by qualified personnel and in accordance with all national and local codes and ordinances.
- Shock hazard. Disconnect power source before servicing. Serious injury or death could result.
- Risk of explosion. Not for use in hazardous locations. Serious injury or death could result.

CAUTION

Waterflow switches that are monitoring wet pipe sprinkler systems shall not be used as the sole initiating device to discharge AFFF, deluge, or chemical suppression systems. Waterflow switches used for this application may result in unintended discharges caused by surges, trapped air, or short retard times.

Important: This document contains important information on the installation and operation of the VSR waterflow switches. Please read all instructions carefully before beginning installation. A copy of this document is required by NFPA 72 to be maintained on site.

General Information

The Model VSR is a vane type waterflow switch for use on wet sprinkler systems. It is UL Listed for use on a steel pipe; schedules 5 through 40, sizes 2" - 6" and is UL Listed and FM Approved for use on steel pipe; schedules 10 through 40, sizes 2" thru 8" (50 mm thru 200 mm). LPC approved sizes are 2" thru 8" (50 mm thru 200 mm). See Ordering Information chart.

The VSR may also be used as a sectional waterflow detector on large systems. The VSR contains two single pole, double throw, snap action switches and an adjustable, instantly recycling pneumatic retard. The switches are actuated when a flow of 10 GPM (38 LPM) or more occurs downstream of the device. The flow condition must exist for a period of time necessary to overcome the selected retard period.

Enclosure

The VSR switches and retard device are enclosed in a general purpose, die-cast housing. The cover is held in place with two tamper resistant screws which require a special key for removal. A field installable cover tamper switch is available as an option which may be used to indicate unauthorized removal of the cover. See bulletin number 5401103 for installation instructions of this switch.

Potter Electric Signal Company, LLC • St. Louis, MO • Phone: 866-956-1211/Canada 888-882-1833 • www.pottersignal.com

Installation (see Fig. 1)

These devices may be mounted on horizontal or vertical pipe. On horizontal pipe they shall be installed on the top side of the pipe where they will be accessible. The device should not be installed within 6" (15 cm) of a fitting which changes the direction of the waterflow or within 24" (60 cm) of a valve or drain.

NOTE: Do not leave cover off for an extended period of time.

Drain the system and drill a hole in the pipe using a hole saw in a slow speed drill (see Fig. 1). Clean the inside pipe of all growth or other material for a distance equal to the pipe diameter on either side of the hole. Roll the vane so that it may be inserted into the hole; do not bend or crease it. Insert the vane so that the arrow on the saddle points in the direction of the waterflow. Take care not to damage the non-corrosive bushing in the saddle. The bushing should fit inside the hole in the pipe. Install the saddle strap and tighten nuts alternately to required torque (see the chart in Fig. 1). The vane must not rub the inside of the pipe or bind in any way.

CAUTION

Do not trim the paddle. Failure to follow these instructions may prevent the device from operating and will void the warranty. Do not obstruct or otherwise prevent the trip stem of the flow switch from moving when water flows as this could damage the flow switch and prevent an alarm. If an alarm is not desired, a qualified technician should disable the alarm system.

Fig. 1

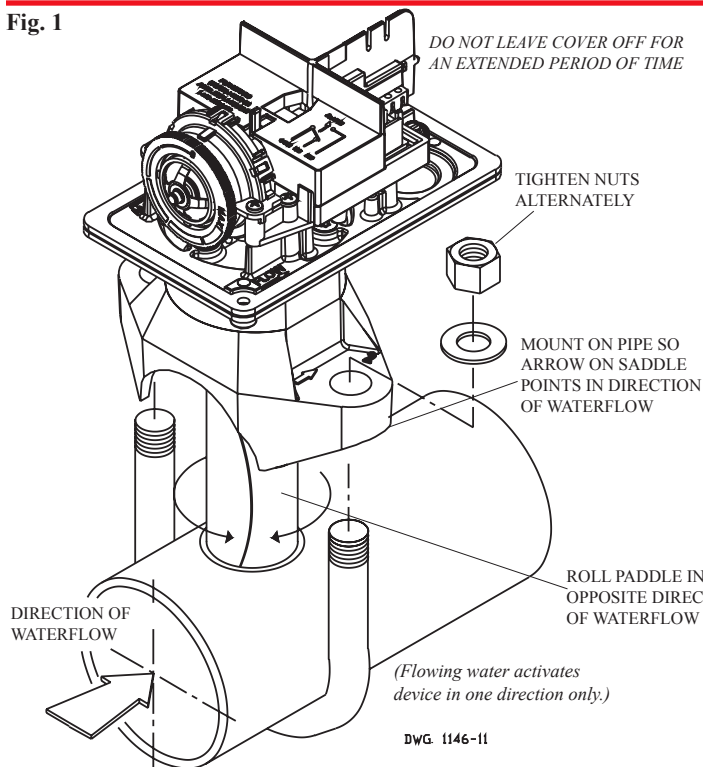

Retard Adjustment

The delay can be adjusted by rotating the retard adjustment knob from 0 to the max setting (60-90 seconds). The time delay should be set at the minimum required to prevent false alarms

CAUTION

Hole must be drilled perpendicular to the pipe and vertically centered. Refer to the Compatible Pipe/Installation Requirements chart for size.

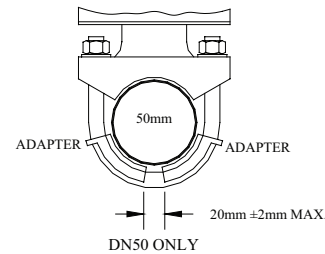

USE (2) 5180162 ADAPTERS AS SHOWN ABOVE

DWG# 1146-1F

Compatible Pipe/ Installation Requirements

Model	Nominal Pipe Size		Nominal Pipe O.D.		Pipe Wall Thickness										Hole Size		U-Bolt Nuts Torque	
	inch	mm	inch	mm	Lightwall		Schedule 10 (UL)		Schedule 40 (UL)		BS-1387 (LPC)		DN (VDS)		inch	mm	ft-lb	n-m
VSR-2	2	DN50	2.375	60.3	.065	1.651	0.109	2.77	0.154	3.91	0.142	3.6	0.091	2.3	1.25 ± .125/ .062	33.0 ± 2.0	20	27
VSR-2 1/2	2.5	-	2.875	73.0	.084	2.134	0.120	3.05	0.203	5.16	-	-	-	-				
VSR-2 1/2	-	DN65	3.000	76.1	-	-	-	-	-	-	0.142	3.6	0.102	2.6				
VSR-3	3	DN80	3.500	88.9	.083	2.108	0.120	3.05	0.216	5.49	0.157	4.0	0.114	2.9	2.00 ± .125	50.8 ± 2.0	20	27
VSR-3 1/2	3.5	-	4.000	101.6	-	-	0.120	3.05	0.226	5.74	-	-	-	-				
VSR-4	4	DN100	4.500	114.3	.084	2.134	0.120	3.05	0.237	6.02	0.177	4.5	0.126	3.2				
VSR-5	5	-	5.563	141.3	-	-	0.134	3.40	0.258	6.55	-	-	-	-				
VSR-6	6	DN150	6.625	168.3	.115	2.921	0.134	3.40	0.280	7.11	0.197	5.0	0.157	4.0				
VSR-8	8	DN200	8.625	219.1	-	-	0.148	3.76	0.322	8.18	0.248	6.3	0.177	4.5				

NOTE: For copper or plastic pipe use Model VSR-CF.

Fig. 2

To remove knockouts: Place screwdriver at inside edge of knockouts, not in the center.

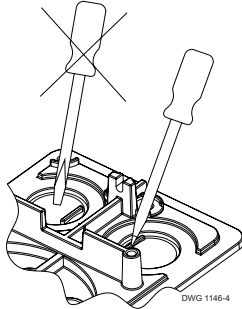

DWG 1146-4

NOTICE

Do not drill into the base as this creates metal shavings which can create electrical hazards and damage the device. Drilling voids the warranty.

Fig. 3

Break out thin section of cover when wiring both switches from one conduit entrance.

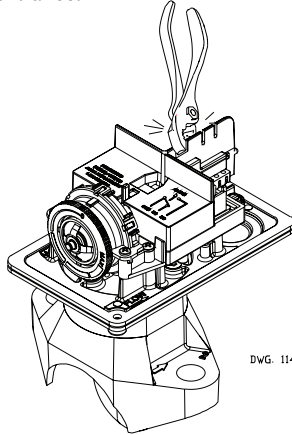

DWG 1146-13

Fig. 4 Switch Terminal Connections Clamping Plate Terminal

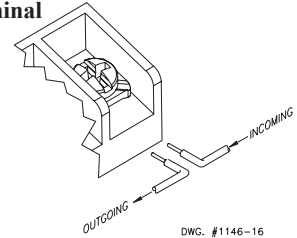

DWG. #1146-16

WARNING

An uninsulated section of a single conductor should not be looped around the terminal and serve as two separate connections. The wire must be severed, thereby providing supervision of the connection in the event that the wire become dislodged from under the terminal. Failure to sever the wire may render the device inoperable risking severe property damage and loss of life.

Do not strip wire beyond 3/8" or length or expose an uninsulated conductor beyond the edge of the terminal block. When using stranded wire, capture all strands under the clamping plate.

Fig. 5 Typical Electrical Connections

Notes:

1. The Model VSR has two switches, one can be used to operate a central station, proprietary or remote signaling unit, while the other contact is used to operate a local audible or visual annunciator.
2. For supervised circuits, see "Switch Terminal Connections" drawing and warning note (Fig. 4).

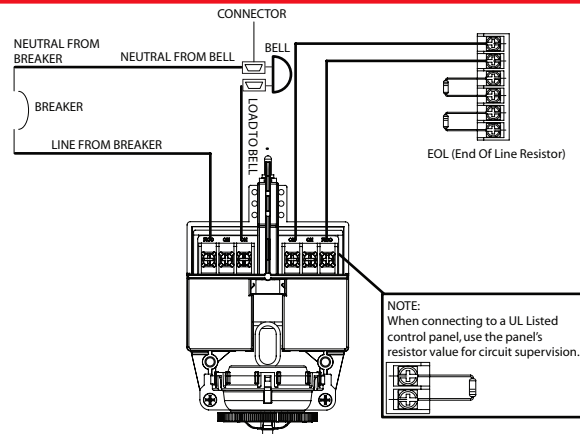

NOTE: When connecting to a UL Listed control panel, use the panel's resistor value for circuit supervision.

Testing

The frequency of inspection and testing for the Model VSR and its associated protective monitoring system shall be in accordance with applicable NFPA Codes and Standards and/or the authority having jurisdiction (manufacturer recommends quarterly or more frequently).

If provided, the inspector's test valve shall always be used for test purposes. If there are no provisions for testing the operation of the flow detection device on the system, application of the VSR is not recommended or advisable.

A minimum flow of 10 GPM (38 LPM) is required to activate this device.

NOTICE

Advise the person responsible for testing of the fire protection system that this system must be tested in accordance with the testing instructions.

Fig. 6 Mounting Dimensions

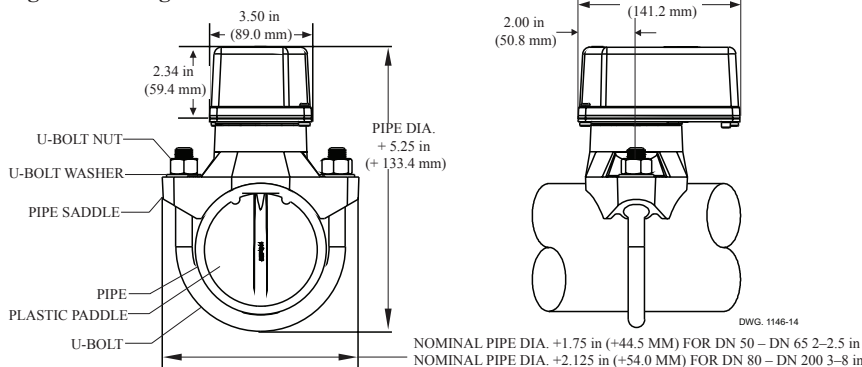

DWG. 1146-14

NOMINAL PIPE DIA. +1.75 in (+44.5 MM) FOR DN 50 - DN 65
NOMINAL PIPE DIA. +2.125 in (+54.0 MM) FOR DN 80 - DN 200

Fig. 7

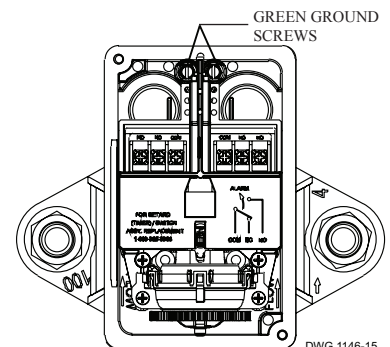

DWG 1146-15

Maintenance

Inspect detectors monthly. If leaks are found, replace the detector. The VSR waterflow switch should provide years of trouble-free service. The retard and switch assembly are easily field replaceable. In the unlikely event that either component does not perform properly, please order replacement retard switch assembly stock #1029030 (see Fig. 8). There is no maintenance required, only periodic testing and inspection.

Retard/Switch Assembly Replacement (See Fig. 8)

NOTICE The Retard/Switch Assembly is field-replaceable without draining the system or removing the waterflow switch from the pipe

1. Make sure the fire alarm zone or circuit connected to the waterflow switch is bypassed or otherwise taken out of service.
2. Disconnect the power source for local bell (if applicable).
3. Identify and remove all wires from the waterflow switch.
4. Remove the (2) mounting screws holding retard/switch assembly to the base. **Do not** remove the (2) retard housing screws.
5. Remove the retard assembly by lifting it straight up over the tripstem.
6. Install the new retard assembly. Make sure the locating pins on the retard/switch assembly fit into the locating pin bosses on the base.
7. Re-install the (2) original mounting screws.
8. Reconnect all wires. Perform a flow test and place the system back in service.

Fig. 8

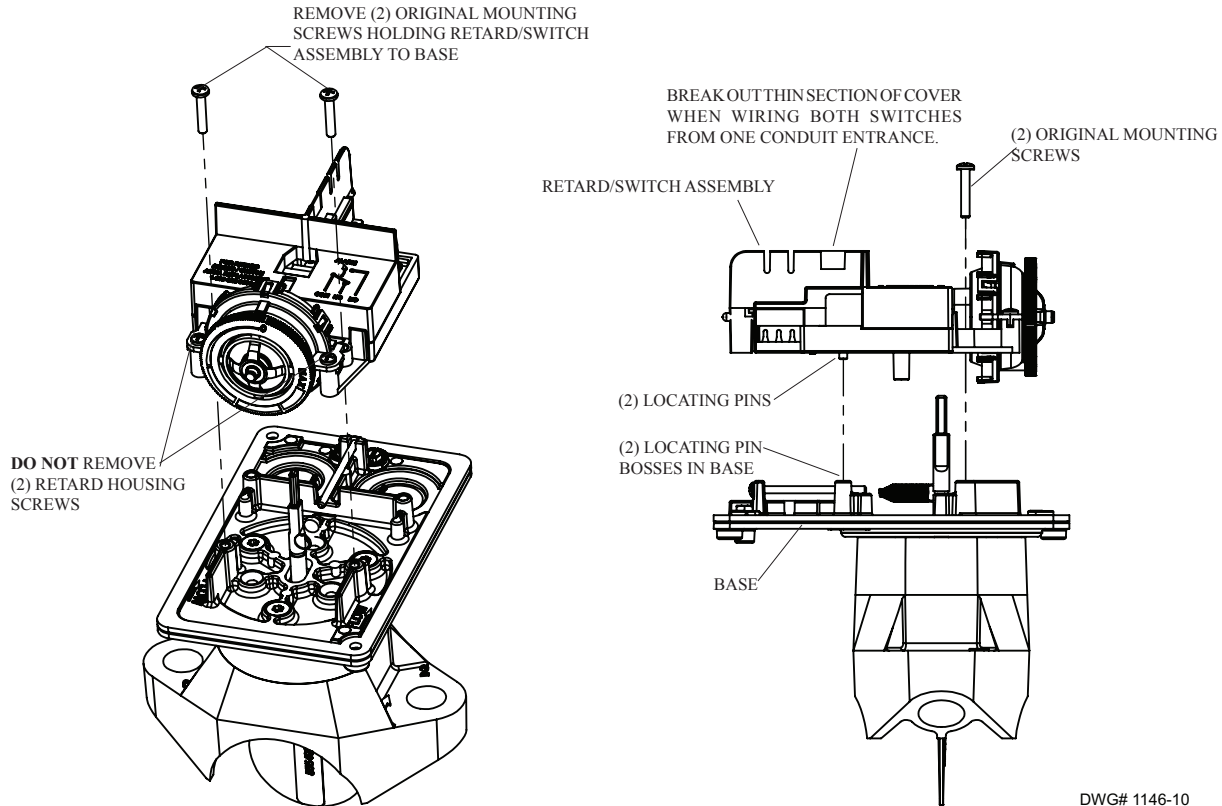

Removal of Waterflow Switch

- To prevent accidental water damage, all control valves should be shut tight and the system completely drained before waterflow detectors are removed or replaced.
- Turn off electrical power to the detector, then disconnect wiring.
- Loosen nuts and remove U-bolts.
- Gently lift the saddle far enough to get your fingers under it. With your fingers, roll the vane so it will fit through the hole while continuing to lift the waterflow detector saddle.
- Lift detector clear of pipe.



PIPE & FITTINGS

SCHEDULE 10 & 40



Always ready to protect your most valuable assets.

As the leading supplier of steel sprinkler pipe, we understand that there are no second chances in fire suppression. You need products of enduring quality and exceptional strength—plus reliable service. You need Bull Moose.

Bull Moose Fire Sprinkler Pipe Product Information

Nominal Pipe Size (Inches)		1"	1-1/4"	1-1/2"	2"	2-1/2"	3"	4"	6"	8"	NPS (In.)		1"	1-1/4"	1-1/2"	2"	2-1/2"	3"	4"	
SCHEDULE 10	O.D. (in)	1.315	1.660	1.900	2.375	2.875	3.500	4.500	6.625	8.625	SCHEDULE 40	1.315	1.660	1.900	2.375	2.875	3.500	4.500		
	I.D. (in)	1.097	1.442	1.682	2.157	2.635	3.260	4.260	6.357	8.249		1.049	1.380	1.610	2.067	2.469	3.068	4.026		
	Empty Weight (lb/ft)	1.410	1.810	2.090	2.640	3.530	4.340	5.620	9.290	16.940		1.680	2.270	2.720	3.660	5.800	7.580	10.800		
	Water Filled Weight (lb/ft)	1.820	2.518	3.053	4.223	5.893	7.957	11.796	23.038	40.086		2.055	2.918	3.602	5.114	7.875	10.783	16.316		
	C.R.R.	15.27	9.91	7.76	6.27	4.92	3.54	2.50	1.158	1.805		1.00	1.00	1.00	1.00	1.00	1.00	1.00		
	Pieces per Lift	91	61	61	37	30	19	19	10	7		70	51	44	30	30	19	19		
	Lift Weight (lbs) 21' lengths	2,695	2,319	2,677	2,051	2,224	1,732	2,242	1,951	2,490		2,470	2,431	2,513	2,306	3,654	3,024	4,309		
	Lift Weight (lbs) 24' lengths	3,079	2,650	3,060	2,344	2,542	1,979	2,563	2,230	2,848		2,822	2,778	2,872	2,635	4,176	3,456	4,925		
	Lift Weight (lbs) 25' lengths	3,208	2,760	3,187	2,442	2,648	2,062	2,670				2,940	2,894	2,992	2,745	4,350	3,601	5,130		

SCHEDULE 10 & 40 ADVANTAGES:

- UL listed (US & Canada) and FM approved
- ASTM A135 and A795 Type E, Grade A Certified
- Complies with NFPA-13, 13R and 14
- Industry-leading hydraulic characteristics
- CRR of 1.0 and greater
- All pipe NDT weld tested

OTHER BENEFITS/SERVICES:

- We have the most stocking locations in the industry, for best delivery and availability
- Plain end or roll groove
- Eddy Guard II™ bacterial-resistant internal coating
- Custom length options
- Hot dipped galvanization
- Reddi-Pipe® red or black pipe eliminates field painting
- Compatible for use in wet, dry, preaction and deluge sprinkler systems
- The only maker with EPDs (to help earn LEED points).

Exclusive maker of Reddi-Pipe®
RED OR BLACK PAINTED PIPE.



cULUS LISTED



BULL MOOSE
TUBE

800.325.4467
sales@BullMooseIndustries.com
BullMooseTube.com

Victaulic® FireLock™ Rigid Coupling

Style 009N



Patented

1.0 PRODUCT DESCRIPTION

Available Sizes

- 1 ¼ – 12"/32 – 300 mm

Pipe Material

- Carbon steel, Schedule 10, Schedule 40. For use with alternative materials and wall thicknesses please contact Victaulic.

Maximum Working Pressure

- Up to 365 psi/2517 kPa.

Function

- Joins carbon steel pipe.
- Provides a rigid pipe joint designed to restrict axial or angular movement.

2.0 CERTIFICATION/LISTINGS



C104-1a/36

ALWAYS REFER TO ANY NOTIFICATIONS AT THE END OF THIS DOCUMENT REGARDING PRODUCT INSTALLATION, MAINTENANCE OR SUPPORT.

System No.		Location	
Submitted By		Date	

Spec Section		Paragraph	
Approved		Date	

3.0 SPECIFICATIONS – MATERIAL

Housing: Ductile iron conforming to ASTM A 536, Grade 65-45-12. Ductile iron conforming to ASTM A 395, Grade 65-45-15, is available upon special request.

Housing Coating: (specify choice)

- Orange enamel (North America, Asia Pacific)
- Red enamel (Europe)
- Hot dipped galvanized

Gasket: (specify choice¹)

Grade “E” EPDM (Type A)

FireLock EZ products have been Listed by Underwriters Laboratories Inc., Underwriters Laboratories of Canada Limited, and Approved by Factory Mutual Research for wet and dry (oil free air) sprinkler services within the rated working pressure.

¹ Services listed are General Service Guidelines only. It should be noted that there are services for which these gaskets are not compatible. Reference should always be made to the latest [Victaulic Gasket Selection Guide](#) for specific gasket service guidelines and for a listing of services which are not compatible.

Bolts/Nuts: (specify choice²)

Standard: Carbon steel oval neck track bolts meeting the physical and chemical requirements of ASTM A449 (imperial) and ISO 898-1 Class 9.8 (metric). Carbon steel hex nuts meeting the physical and chemical requirements of ASTM A563 Grade B (imperial - heavy hex nuts) and ASTM A563M Class 9 (metric - hex nuts). Track bolts and hex nuts are zinc electroplated per ASTM B633 ZN/FE5, finish Type III (imperial) or Type II (metric).

Optional: Stainless steel oval neck track bolts meeting the requirements of ASTM F593, Group 2 (316 stainless steel), condition CW. Stainless steel heavy hex nuts meeting the requirements of ASTM F594, Group 2 (316 stainless steel), condition CW, with galling-resistant coating.²

² Optional bolts/nuts are available in imperial size only.

4.0 DIMENSIONS

Style 009N

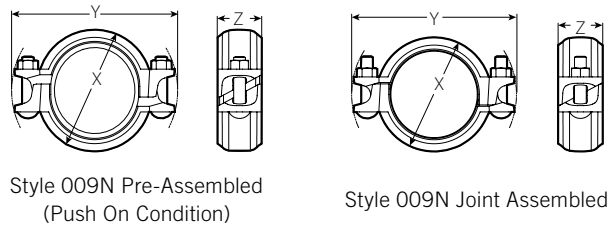

Nominal Size	Actual Outside Diameter	Maximum Working Pressure ³	Maximum End Load ³	Allow. Pipe End Separation ⁴	Qty.	Bolt/Nut Size	Dimensions					Weight Approx. (Each)
							Pre-assembled (Push On Condition)		Joint Assembled			
							X	Y	X	Y	Z	
1 ¼ 32	1.660 42.4	365 2517	790 3514	0.10 2.54	2	¾ × 2 M10 × 51	3.13 79	5.00 127	2.75 70	5.00 127	2.00 51	1.4 0.6
1 ½ 40	1.900 48.3	365 2517	1035 4604	0.10 2.54	2	¾ × 2 M10 × 51	3.38 86	5.13 130	3.00 76	5.13 130	2.00 51	1.5 0.7
2 50	2.375 60.3	365 2517	1616 7193	0.12 3.05	2	¾ × 2 ½ M10 × 63	4.00 102	5.63 143	3.50 89	5.63 143	2.00 51	1.9 0.9
2 ½ 65	2.875 73.0	365 2517	2370 10542	0.12 3.05	2	¾ × 2 ½ M10 × 63	4.50 114	6.13 156	4.00 102	6.13 156	2.00 51	2.1 1.0
76.1 mm	3.000 76.1	365 2517	2580 11476	0.12 3.05	2	¾ × 2 ½ M10 × 63	4.63 118	6.00 152	4.13 105	6.13 156	2.00 51	2.1 1.0
3 80	3.500 88.9	365 2517	3512 15622	0.12 3.05	2	¾ × 2 ½ M10 × 63	5.13 130	6.75 171	4.63 117	6.75 171	2.00 51	2.3 1.0
4 100	4.500 114.3	365 2517	5805 25822	0.17 4.32	2	¾ × 2 ½ M10 × 63	6.00 152	7.88 200	5.63 143	7.50 191	2.13 54	2.9 1.3
108.0 mm	4.250 108.0	365 2517	5175 23020	0.17 4.32	2	¾ × 2 ½ M10 × 63	5.63 152	7.38 187	5.38 137	7.38 187	2.13 54	3.1 1.4
5 125	5.563 141.3	365 2000	8870 39456	0.17 4.32	2	½ × 3 M12 × 76	7.25 184	9.25 235	6.75 171	9.13 232	2.25 57	5.0 2.3
133.0 mm	5.250 133.0	365 2517	7897 35106	0.17 4.32	2	½ × 3 M12 × 76	6.63 168	9.00 229	6.38 162	9.00 229	2.25 57	4.8 2.2
139.7 mm	5.500 139.7	365 2517	8667 38529	0.17 4.32	2	½ × 3 M12 × 76	6.88 175	9.25 235	6.75 171	9.13 232	2.25 57	4.9 2.2
159.0 mm	6.250 159.0	365 2517	11192 49753	0.17 4.32	2	½ × 3 ¼ M12 × 83	7.88 200	10.00 254	7.38 187	9.88 251	2.25 57	5.6 2.5
165.1 mm	6.500 165.1	365 2517	12105 53813	0.17 4.32	2	½ × 3 ¼ M12 × 83	8.00 203	10.25 260	7.75 197	10.13 257	2.25 57	6.0 2.7
6 150	6.625 168.3	365 2000	12582 44469	0.17 4.32	2	½ × 3 ¼ M12 × 83	8.38 213	10.38 264	7.88 200	10.13 257	2.25 57	6.0 2.7
216.0 mm	8.500 216.0	365 2517	20712 59968	0.17 4.32	2	¾ × 4 M16 × 101	10.63 270	13.25 337	10.25 260	10.13 257	2.63 67	11.4 5.2
8 200	8.625 219.1	365 1620	21326 94863	0.17 4.32	2	¾ × 4 M16 × 101	10.88 276	13.38 340	10.25 260	13.13 333	2.50 64	11.4 5.2
10 250	10.750 273.0	300 2068	27229 121121	0.25 6.4	2	7/8 × 6 ½ M22 × 165	13.75 349	17.00 432	13.25 337	17.13 435	2.75 70	22.6 10.3
12 300	12.750 323.9	300 2068	38303 170380	0.25 6.4	2	7/8 × 6 ½ M22 × 165	16.00 406	19.00 483	15.50 394	19.13 486	2.75 70	27.6 12.5

³ Working Pressure and End Load are total, from all internal and external loads, based on standard weight (ANSI) steel pipe, standard roll or cut grooved in accordance with Victaulic specifications. See the Listings/Approvals section of this publication for ratings on other pipe.

⁴ The allowable pipe separation dimension shown is for system layout purposes only. FireLock EZ™ couplings are considered rigid connections and will not accommodate expansion or contraction of the piping system.

NOTES

- When assembling FireLock EZ™ couplings onto end caps, take additional care to make certain the end cap is fully seated against the gasket end stop. For FireLock EZ™ Style 009N couplings, use FireLock No. 006 end caps containing the “EZ” marking on the inside face or No. 60 end caps containing the “QV EZ” marking on the inside face. Non-Victaulic end cap products shall not be used with Style 009N couplings. IMPORTANT: Gaskets intended for the Style 009 or Style 009V couplings cannot be used with the Style 009N coupling. There is no interchanging of gaskets or housings between coupling styles.
- Use Of Flushseal Gaskets For Dry Pipe Systems** FireLock EZ™ couplings are supplied with FireLock EZ™ Grade “E” Type A gaskets. These gaskets include an integral pipe stop, that once installed provides the similar benefits as a FlushSeal gasket for dry pipe systems. It should be noted that standard Victaulic Flush-Seal™ gaskets are not compatible and cannot be used with the FireLock EZ™ couplings.

5.0 PERFORMANCE⁶

Listings/Approval

The information provided below is based on the latest listing and approval data at the time of publication. Listings/Approvals are subject to change and/or additions by the approvals agencies. Contact Victaulic for performance on other pipe and the latest listings and approvals.

Nominal Size inches mm	cULus ¹¹			FM			Vds	LPCB
	Sch. 5 psi kPa	Sch. 10 psi kPa	Sch. 40 psi kPa	Sch. 5 psi kPa	Sch. 10 psi kPa	Sch. 40 psi kPa	psi kPa	psi kPa
1 ¼ 32	232 1600	365 2517	365 2517	175 1205	363 2502	363 2502	363 2500	363 2500
1 ½ 40	232 1600	365 2517	365 2517	175 1205	363 2502	363 2502	363 2500	363 2500
2 50	363 2502	365 2517	365 2517	175 1205	363 2502	363 2502	363 2500	363 2500
2 ½ 65	N/A	365 2517	365 2517	175 1205	363 2502	363 2502	363 2500	363 2500
76.1 mm	N/A	365 ⁶ 2517 ⁶	N/A	N/A	363 ⁷ 2502 ⁷	N/A	363 2500	363 2500
3 80	N/A	365 2517	365 2517	175 1205	363 2502	363 2502	363 2500	363 2500
4 100	N/A	365 2517	365 2517	175 1205	363 2502	363 2502	363 2500	363 2500
108.0 mm	N/A	N/A	N/A	175 1205	363 2502	363 2502	N/A	N/A
5 125	N/A	290 2000	365 2517	N/A	363 2502	363 2502	232 1600	N/A
133.0 mm	N/A	N/A	N/A	N/A	363 ⁷ 2502 ⁷	N/A	N/A	N/A
139.7 mm	N/A	290 ⁸ 2000 ⁸	N/A	N/A	363 ⁷ 2502 ⁷	N/A	232 1600	N/A
159.0 mm	N/A	N/A	N/A	N/A	363 ⁷ 2502 ⁷	N/A	N/A	N/A
165.1 mm	N/A	290 ⁹ 2000 ⁹	N/A	N/A	363 ⁷ 2502 ⁷	N/A	N/A	N/A
6 150	N/A	290 2000	365 2517	N/A	363 2502	363 2502	232 1600	N/A
216.0 mm	N/A	N/A	N/A	N/A	363 ⁷ 2502 ⁷	N/A	N/A	N/A
8 200	N/A	290 2000	365 2517	N/A	363 2502	363 2502	232 1600	N/A
216.0 mm	N/A	N/A	N/A	N/A	363 ⁷ 2502 ⁷	N/A	N/A	N/A
8 200	N/A	290 2000	365 2517	N/A	363 2502	363 2502	232 1600	N/A
10 250	N/A	300 2068	300 2068	N/A	300 2068	300 2068	N/A	N/A
12 300	N/A	300 ¹⁰ 2068 ¹⁰	300 2068	N/A	250 1724	300 2068	N/A	N/A

⁵ Listed/Approved for wet and dry pipe systems (> -40°F/-40°C) for continuous use in freezing conditions, use of Style 005H Coupling with Silicone Gasket is recommended. Please see the Victaulic [Installation Manual I-009N/009H](#) for details concerning when supplemental lubrication is required.

⁶ cULus listed for DIN 2458 2.6 mm pipe wall.

⁷ FM approved for BS 1387 Medium 3.6 mm pipe wall.

⁸ cULus listed for EN 10220 4.0 mm pipe wall.

⁹ cULus listed for EN 10255 4.5 mm pipe wall.

¹⁰ cUL listed to 250 psi.

¹¹ With optional stainless steel fasteners, cULus Listed to 175psi. The stainless steel fasteners have a marking designation of "316" on the end face of the bolt.

5.1 PERFORMANCE²

Listings/Approval Speciality Pipe

Pipe	Size inches	Pressure Rating		Pipe	Size inches	Pressure Rating		Pipe	Size inches	Pressure Rating	
		cULus psi kPa	FM psi kPa			cULus psi kPa	FM psi kPa			cULus psi kPa	FM psi kPa
BLT	1 ¼ – 2	300 2068	365 2517	EZT	1 ¼ – 2	300 2068	365 2517	MT	1 ¼ – 2	300 2068	365 2517
DF	1 ¼ – 4	300 2068	365 2517	FF	1 ¼ – 4	300 2068	365 2517	MLT	1 ¼ – 2	N/A	365 2517
DT	1 ¼ – 2	300 2068	365 2517	FLF	1 ¼ – 4	N/A	365 2517	ST	1 ¼ – 2	N/A	365 2517
EF	1 ¼ – 4	175 1206	175 1206	FLT	1 ¼ – 2	N/A	365 2517	STF	1 ¼ – 4	N/A	365 2517
EL	1 ¼ – 2	300 2068	365 2517	FLTL	1 ¼ – 2	N/A	365 2517	TF	2 ¼ – 4	N/A	365 2517
ET40	1 ¼ – 2	300 2068	365 2517	GL	1 ¼ – 2	300 2068	365 2517	WLS	1 ¼ – 2	300 2068	365 2517
EZF	3 – 4	300 2068	365 2517	MF	1 ¼ – 4	300 2068	365 2517	WST	1 ¼ – 2	N/A	365 2517
								XL	1 ¼ – 2	300 2068	365 2517

NOTES

- BLT = BLT steel pipe manufactured by Allied Tube & Conduit Corp.
- DF = DYNA-FLOW steel pipe manufactured by Allied Tube & Conduit Corp.
- DT = DYNA-FLOW steel pipe manufactured by Allied Tube & Conduit Corp.
- EF = EDDY FLOW steel pipe manufactured by Bull Moose Tube Co.
- EL = EDDYLITE steel pipe manufactured by Bull Moose Tube Co.
- ET40 = Eddythread 40 steel pipe manufactured by Bull Moose Tube Co.
- EZF = EZ-Flow steel pipe manufactured by Northwest Pipe Co.
- EZT = EZ-Thread steel pipe manufactured by Youngstown Tube Co.
- FF = Fire-Flo steel pipe manufactured by Youngstown Tube Co.
- FLF = Fire-Line Flow steel pipe manufactured by Western International Forest Products Inc.
- FLT = Fire-Line Threadable steel pipe manufactured by Western International Forest Products Inc.
- FLTL = Fire-Line Threadable Light steel pipe manufactured by Western International Forest Products Inc.
- GL = GL steel pipe manufactured by Wheatland Tube Co.
- MF = Mega-Flow steel pipe manufactured by Wheatland Tube Co.
- MT = Mega-Thread steel pipe manufactured by Wheatland Tube Co.
- MLT = MLT steel pipe manufactured by Wheatland Tube Co.
- ST = STD wall pipe in accordance with ASTM A53.
- STF = Steady Flow steel pipe manufactured by AMS Tube Corp.
- TF = Tex-Flow steel pipe manufactured by Tex-Tube Co.
- WLS = WLS steel pipe manufactured by Wheatland Tube Co.
- WST = WST steel pipe manufactured by Wheatland Tube Company.
- XL = XL steel pipe manufactured by Allied Tube & Conduit Corp.

6.0 NOTIFICATIONS

Not applicable – contact Victaulic with any questions.

7.0 REFERENCE MATERIALS

[05.01: Seal Selection Guide](#)

[I-009N/009H](#): Installation Instructions FireLock EZ™ Rigid Coupling

User Responsibility for Product Selection and Suitability

Each user bears final responsibility for making a determination as to the suitability of Victaulic products for a particular end-use application, in accordance with industry standards and project specifications, and the applicable building codes and related regulations as well as Victaulic performance, maintenance, safety, and warning instructions. Nothing in this or any other document, nor any verbal recommendation, advice, or opinion from any Victaulic employee, shall be deemed to alter, vary, supersede, or waive any provision of Victaulic Company's standard conditions of sale, installation guide, or this disclaimer.

Intellectual Property Rights

No statement contained herein concerning a possible or suggested use of any material, product, service, or design is intended, or should be constructed, to grant any license under any patent or other intellectual property right of Victaulic or any of its subsidiaries or affiliates covering such use or design, or as a recommendation for the use of such material, product, service, or design in the infringement of any patent or other intellectual property right. The terms "Patented" or "Patent Pending" refer to design or utility patents or patent applications for articles and/or methods of use in the United States and/or other countries.

Note

This product shall be manufactured by Victaulic or to Victaulic specifications. All products to be installed in accordance with current Victaulic installation/assembly instructions. Victaulic reserves the right to change product specifications, designs and standard equipment without notice and without incurring obligations.

Installation

Reference should always be made to the Victaulic installation handbook or installation instructions of the product you are installing. Handbooks are included with each shipment of Victaulic products, providing complete installation and assembly data, and are available in PDF format on our website at www.victaulic.com.

Warranty

Refer to the Warranty section of the current Price List or contact Victaulic for details.

Trademarks

Victaulic and all other Victaulic marks are the trademarks or registered trademarks of Victaulic Company, and/or its affiliated entities, in the U.S. and/or other countries.



No. 20 Tee



No. 10 Elbow

1.0 PRODUCT DESCRIPTION

Available Sizes

- ¾ – 60"/DN20 – DN1500

Maximum Working Pressure

- Pressure ratings for Victaulic standard fittings conform to the ratings of Victaulic Style 177N couplings (refer to [publication 06.24](#) for more information).

Application

- Connects pipe, provides change in direction and adapts sizes or components
- Supplied with Victaulic OGS grooves
- Exclusively for use with Victaulic couplings, valves, accessories and pipe which feature ends formed with the Victaulic OGS groove profile

Pipe Materials

- Carbon steel or stainless steel

NOTE

- These fittings are not intended for use with Victaulic plain end couplings. Intended for use only in grooved piping systems. When connecting wafer or lug type butterfly valves directly to Victaulic fittings using Style 741 or Style 743 flange adapters, be sure to check disc clearance dimensions with I.D. dimension of fitting.

ALWAYS REFER TO ANY NOTIFICATIONS AT THE END OF THIS DOCUMENT REGARDING PRODUCT INSTALLATION, MAINTENANCE OR SUPPORT.

System No.		Location	
Submitted By		Date	

Spec Section		Paragraph	
Approved		Date	

1.0 PRODUCT DESCRIPTION (Continued)

Other Fitting Styles



AGS - Advanced Groove System
from 14 – 60"/DN350 – DN1500
[Publication 20.05](#)



Ductile Iron for AWWA size pipe
[Publication 23.05](#)



Stainless Steel
[Publication 17.16](#)



XL fittings for abrasive services
[Publication 07.07](#)



Galvanized
[Publication 07.01](#) for Original Groove Fittings
[Publication 20.05](#) for AGS Fittings



Aluminum
[Publication 21.03](#)



Extra Heavy EndSeal "ES"
[Publication 07.03](#)



Shouldered Ends
[Publication 07.06](#)



Copper
[Publication 22.04](#)



Plain End
[Publication 14.04](#)

2.0 CERTIFICATION/LISTINGS



NOTES

- When supplied as “hot dip galvanized” the following fittings are UL Classified in accordance with ANSI/NSF 61 and for use on cold +86°F/+30°C potable water service and ANSI/NSF 372: No. 10 90° Elbow, No. 11 45° Elbow, No. 12 22 ½° Elbow, No. 13 11 ¼° Elbow, No. 100 90° Long Radius Elbow, No. 110 45° Long Radius Elbow, No. 20 Tee, No. 25 Tee with Grooved Branch, No. 30 45° Lateral, No. 60 Cap, No. 50 Concentric Reducers, No. 51 Eccentric Reducers.
- The following Victaulic fittings are VdS approved: No.10 90° Elbow, No.11 45° Elbow, No.20 Tee and No.60 Cap.
- The following Victaulic fittings are LPCB approved: No.10 90° Elbow, No.11 45° Elbow, No.12 22 ½° Elbow, No.13 11 ¼° Elbow, No.30 45° Lateral, No.30-R Reducing Lateral, No.100 Long Radius Elbow, No.110 Long Radius Elbow, No.20 Tee, No.35 Cross, No.60 Cap, No.25 Reducing Tee, No.33 True Wye, No.50 Concentric Reducer, No.51 Eccentric Reducer and No.29M Tee with Threaded Branch.
- The following Victaulic fittings are FM approved: No.10 90° Elbow, No.11 45° Elbow, No.12 22 ½° Elbow, No.13 11 ¼° Elbow, No.30 45° Lateral, No.100 Long Radius Elbow, No.20 Tee, No.35 Cross, No.60 Cap, No.25 Reducing Tee and No.50 Concentric Reducer.

3.0 SPECIFICATIONS - MATERIAL

Fitting: (specify choice)

Standard: Ductile iron conforming to ASTM A536, Grade 65-45-12.

Optional: Segmentally welded steel as shown under nipples

Nipples: (specify choice)

¾ – 4"/DN20 – DN100: Carbon steel, Schedule 40, conforming to ASTM A53, Type F

5 – 6"/DN125 – DN150: Carbon steel, Schedule 40, conforming to ASTM A53, Type E or S, Gr. B

8 – 12"/DN200 – DN300: Carbon steel, Schedule 30 or 40, conforming to ASTM A53, Type E or S, Gr. B

Flanged Adapter Nipples: (specify choice)

Class 125 Flange: Cast iron conforming to ANSI B16.1

Class 150 Flange: Carbon steel conforming to ANSI B16.5, raised or flat face

Class 300 Flange: Carbon steel conforming to ANSI B16.5, raised or flat face

Fitting Coating: (specify choice)

Standard: Orange enamel

Optional: Hot dip galvanized and others. Some fittings supplied electroplated as standard – see product specifications

Flanged Adapter Nipple Coating: (specify choice)

Standard: None (Unfinished)

Optional: Orange enamel, hot dip galvanized and others

4.0 DIMENSIONS

Elbows

- No. 10** 90° Elbow
- No. 11** 45° Elbow
- No. 12** 22 1/2° Elbow
- No. 13** 11 1/4° Elbow
- No. 100** 90° Long Radius Elbow
- No. 110** 45° Long Radius Elbow

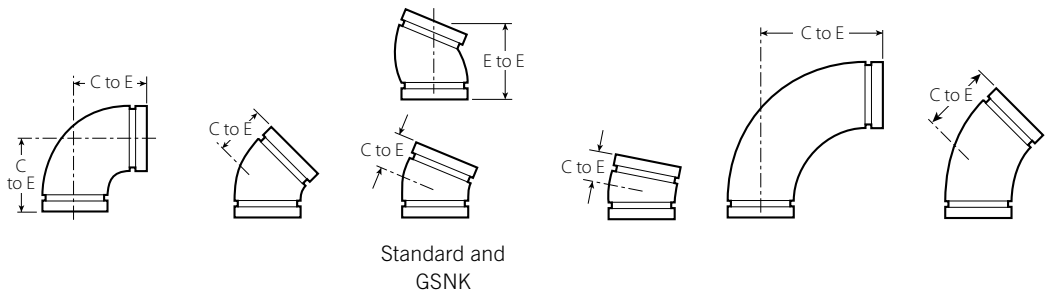

Standard and GSNK

Size		No. 10 90° Elbow		No. 11 45° Elbow		No. 12 22 1/2° Elbow		No. 13 11 1/4° Elbow		No. 100 90° Long Radius Elbow		No. 110 45° Long Radius Elbow	
Nominal	Actual Outside Diameter	C to E	Approx. Wgt. (Each)	C to E	Approx. Wgt. (Each)	C to E	Approx. Wgt. (Each)	C to E	Approx. Wgt. (Each)	C to E	Approx. Wgt. (Each)	C to E	Approx. Wgt. (Each)
inches DN	inches mm	inches mm	lb kg	inches mm	lb kg	inches mm	lb kg	inches mm	lb kg	inches mm	lb kg	inches mm	lb kg
3/4 DN20	1.050 26.9	2.25 57	0.5 0.2	1.50 38	0.5 0.2	1.63 (sw) 41	—	1.38 (sw) 35	—	2.50 (sw) 64	0.4 0.2	1.88 (sw) 48	0.3 0.1
1 DN25	1.315 33.7	2.25 57	0.6 0.3	1.75 44	0.6 0.3	3.25 ¹ 83	0.6 0.3	1.38 (sw) 35	0.3 0.1	2.88 (sw) 73	0.6 0.3	2.25 (sw) 57	0.5 0.2
1 1/4 DN32	1.660 42.4	2.75 70	1.0 0.5	1.75 44	0.9 0.4	1.75 44	0.8 0.4	1.38 (sw) 35	0.5 0.2	3.25 (sw) 83	1.1 0.5	2.38 (sw) 60	0.7 0.3
1 1/2 DN40	1.900 48.3	2.75 70	1.2 0.5	1.75 44	0.9 0.4	1.75 44	0.8 0.4	1.38 (sw) 35	0.5 0.2	3.63 (sw) 92	2.2 1.0	2.50 (sw) 64	1.3 0.6
2 DN50	2.375 60.3	3.25 83	1.8 0.8	2.00 51	1.3 0.6	1.88 48	1.2 0.5	1.38 35	1.0 0.5	4.38 111	2.5 1.1	2.75 70	1.8 0.8
2 1/2 DN65	2.875 73.0	3.75 95	3.2 1.5	2.25 57	2.2 1.0	4.00 ¹ 102	2.3 1.0	1.50 38	1.1 0.5	5.13 130	3.4 1.5	3.00 76	2.8 1.3
3 DN80	3.000 76.1	3.75 95	3.7 1.7	2.25 57	3.4 1.5	2.25 57	—	1.50 38	—	—	—	—	—
3 1/2 DN90	3.500 88.9	4.25 108	4.5 2.0	2.50 64	3.1 1.4	4.50 ¹ 114	3.1 1.4	1.50 38	2.1 1.0	5.88 149	6.0 2.7	3.38 86	4.9 2.2
4 DN100	4.000 101.6	4.50 114	5.6 2.5	2.75 70	4.3 2.0	2.50 (sw) 64	4.0 1.8	1.75 (sw) 44	2.7 1.2	—	—	—	—
	4.500 114.3	5.00 127	7.1 3.2	3.00 76	5.6 2.5	2.88 73	5.6 2.5	1.75 44	3.6 1.6	7.50 191	12.3 5.6	4.00 102	7.3 3.3
	4.250 108.0	5.00 127	11.0 5.0	3.00 76	5.6 2.5	—	—	—	—	—	—	—	—
	5.000 127.0	5.25 (sw) 133	10.0 4.5	3.13 (sw) 79	6.0 2.7	3.50 (sw) 89	6.6 3.0	1.88 (sw) 48	4.2 1.9	—	—	—	—
5	5.563 141.3	5.50 140	11.7 5.3	3.25 83	8.3 3.8	2.88 (sw) 73	7.8 3.5	2.00 (sw) 51	5.0 2.2	9.25 (sw) 235	18.0 8.2	4.88 (sw) 124	14.8 6.7
	5.250 133.0	5.50 140	11.7 5.3	3.25 83	8.3 3.8	—	—	—	—	—	—	—	—
DN125	5.500 139.7	5.50 140	11.7 5.3	3.25 83	8.3 3.8	2.88 73	—	2.00 51	—	—	—	—	—
6 DN150	6.625 168.3	6.50 165	17.2 7.8	3.50 89	10.8 4.9	6.25 ¹ 159	12.2 5.5	2.00 51	7.0 3.2	10.75 273	30.4 13.8	5.50 140	17.4 7.9
	6.250 159.0	6.50 165	18.6 8.4	3.50 89	10.8 4.9	—	—	—	—	—	—	—	—
	6.500 165.1	6.50 165	15.5 7.0	3.50 89	9.8 4.4	3.13 79	11.4 5.2	2.00 51	7.4 3.4	10.75 (sw) 273	29.0 13.2	5.50 (sw) 140	19.0 8.6

¹ Gooseneck design, end-to-end dimension fittings in this size, contact your nearest Victaulic sales representative.

(s) = Carbon Steel Direct Roll Groove (OGS)

(sw) = Carbon Steel Segmentally Welded

NOTE

- All fittings are ductile iron unless otherwise noted with an (sw) or (s).

4.0 DIMENSIONS (Continued)

Elbows

- No. 10 90° Elbow
- No. 11 45° Elbow
- No. 12 22 1/2° Elbow
- No. 13 11 1/4° Elbow
- No. 100 90° Long Radius Elbow
- No. 110 45° Long Radius Elbow

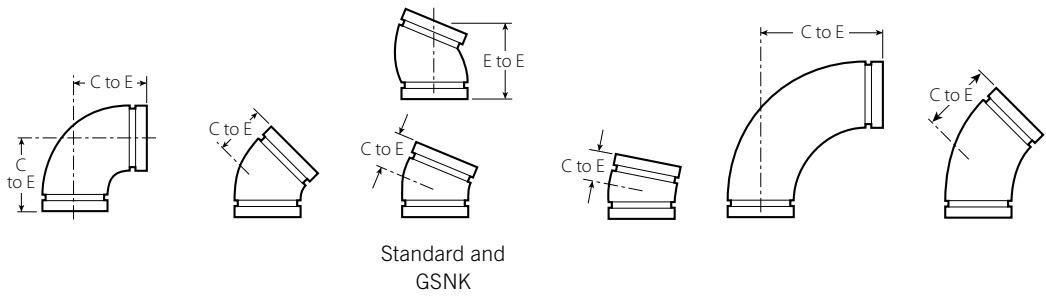

Standard and GSNK

Size		No. 10 90° Elbow		No. 11 45° Elbow		No. 12 22 1/2° Elbow		No. 13 11 1/4° Elbow		No. 100 90° Long Radius Elbow		No. 110 45° Long Radius Elbow	
Nominal	Actual Outside Diameter	C to E	Approx. Wgt. (Each)	C to E	Approx. Wgt. (Each)	C to E	Approx. Wgt. Each	C to E	Approx. Wgt. (Each)	C to E	Approx. Wgt. (Each)	C to E	Approx. Wgt. (Each)
inches DN	inches mm	inches mm	lb kg	inches mm	lb kg	inches mm	lb kg	inches mm	lb kg	inches mm	lb kg	inches mm	lb kg
8 DN200	8.625 219.1	7.75 197	29.9 13.6	4.25 108	20.4 9.3	7.75 ¹ 197	20.0 9.1	2.00 51	10.1 4.6	14.25 362	66.0 30.0	7.25 184	36.0 16.3
10 DN250	10.750 273.0	9.00 229	63.3 28.7	4.75 121	37.5 17.0	4.38 (sw) 111	30.0 13.6	2.13 54	11.8 5.3	15.00 381	107.0 48.5	6.25 159	57.0 25.9
12 DN300	12.750 323.9	10.00 254	74.0 33.6	5.25 133	66.7 30.3	4.88 (sw) 124	40.0 18.1	2.25 57	29.3 13.3	18.00 457	156.0 70.8	7.50 191	90.0 40.8
14 ² DN350	14.000 355.6	14.00 356	136.0 61.7	5.75 146	65.0 29.5	5.00 (sw) 127	46.0 20.9	3.50 (sw) 89	32.0 14.5	21.00 (s) 533	164.0 74.4	8.75 222	82.0 37.2
	14.843 377.0	14.84 377	149.3 67.7	6.13 156	82.0 37.2	—	—	—	—	—	—	—	—
16 ² DN400	16.000 406.5	16.00 406	171.0 77.6	6.63 168	88.0 39.3	5.00 (sw) 127	58.0 26.3	4.00 (sw) 102	42.0 19.1	24.00 (s) 610	210.0 95.3	10.00 (s) 254	100.0 45.4
	16.773 426.0	16.75 425	198.6 90.1	7.00 178	101.3 45.9	—	—	—	—	—	—	—	—
18 ² DN450	18.000 457.2	18.00 457	228.0 103.4	7.50 190	108.0 50.0	5.50 (sw) 140	65.0 29.5	4.50 (sw) 144	53.2 24.1	27.00 (s) 686	273.0 123.8	11.25 (s) 286	135.0 61.2
	18.898 480.0	18.88 480	291.0 132.0	7.83 200	141.7 64.3	—	—	—	—	—	—	—	—
20 ² DN500	20.000 508.0	20.00 508	298.0 135.2	8.25 210	138.0 62.6	6.00 (sw) 152	78.6 36.0	5.00 (sw) 127	65.0 29.5	30.00 (s) 762	343.0 155.6	12.50 (s) 318	174.0 78.9
	20.866 530.0	20.88 530	355.0 161.0	8.63 219	179.0 81.2	—	—	—	—	—	—	—	—
24 ² DN600	24.000 609.6	24.00 610	438.0 198.7	10.00 254	221.0 100.2	7.00 (sw) 178	140.0 63.5	6.00 (sw) 152	60.0 27.2	36.00 (s) 914	516.0 234.1	15.00 (s) 381	251.0 113.9
	24.803 630.0	24.80 630	545.0 247.2	10.25 261	255.2 115.7	—	—	—	—	—	—	—	—
14 – 60 DN350 – DN1500	For AGS fitting information, see publication 20.05												

¹ Gooseneck design, end-to-end dimension fittings in this size, contact your nearest Victaulic sales representative.
² For 14"/DN350 and larger roll grooved systems, Victaulic offers the Advanced Groove System (AGS). For pricing and availability of cut groove fittings in this size, contact your nearest Victaulic sales representative.
(s) = Carbon Steel Direct Roll Groove (OGS)
(sw) = Carbon Steel Segmentally Welded

NOTE

- All fittings are ductile iron unless otherwise noted with an (sw) or (s).

4.1 DIMENSIONS

Reducing Base Support Elbow

No. R-10G Grv. x Grv.

No. R-10F Grv. x Flange

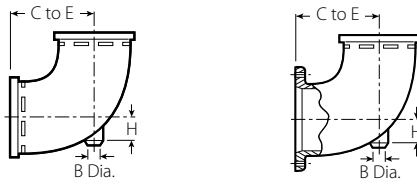

Size		No. R-10 Reducing Base Support Elbow			Approx. Weight Each		
Nominal inches DN		C to E inches mm	H inches mm	B Diameter inches mm	Grv. x Grv. lb kg	Grv. x Flange lb kg	
6 DN150	x	4 DN100	9.00 229	1.25 32	1.50 38	19.0 8.6	33.0 15.0
		5	9.00 229	1.50 38	1.50 38	23.0 10.4	38.0 17.2
8 DN200	x	6 DN150	10.50 267	2.13 24	1.50 38	33.0 15.0	52.0 23.6
		8 DN200	12.00 305	2.40 61	1.50 38	61.0 27.7	88.0 39.9

4.2 DIMENSIONS

Adapter Elbow

No. 18 90° Adapter Elbow

No. 19 45° Adapter Elbow



Size		No. 18 90° Adapter Elbow			No. 19 45° Adapter Elbow		
Nominal inches DN	Actual Outside Diameter inches mm	C to GE inches mm	C to TE inches mm	Approximate Weight (Each) lb kg	C to GE inches mm	C to TE inches mm	Approx. Weight (Each) lb kg
¾ DN20	1.050 26.9	2.25 57	2.25 57	0.5 0.2	1.50 38	1.50 38	0.5 0.2
1 DN25	1.315 33.7	2.25 57	2.25 57	0.5 0.2	—	—	—
1¼ DN32	1.660 42.4	2.75 70	2.75 70	0.9 0.4	—	—	—
1½ DN40	1.900 48.3	2.75 70	2.75 70	1.1 0.5	1.75 44	1.75 44	0.9 0.4
2 DN50	2.375 60.3	3.25 83	4.25 108	2.5 1.1	—	—	—
2½	2.875 73.0	3.75 95	3.75 95	3.0 1.4	2.25 57	2.25 57	2.3 1.0
3 DN80	3.500 88.9	4.25 108	6.00 152	5.8 2.6	2.50 64	4.25 108	5.0 2.3
3½ DN90	4.000 101.6	4.50 114	6.25 159	8.0 3.6	5.25 133	5.25 133	8.8 4.0
6 DN150	6.625 168.3	6.50 165	6.50 165	17.6 8.0	3.50 89	3.50 89	12.7 5.8

NOTE

- Available with British Standard Pipe Threads, specify "BSP" clearly on order.

4.3 DIMENSIONS

Tees, Crosses and True Wyes

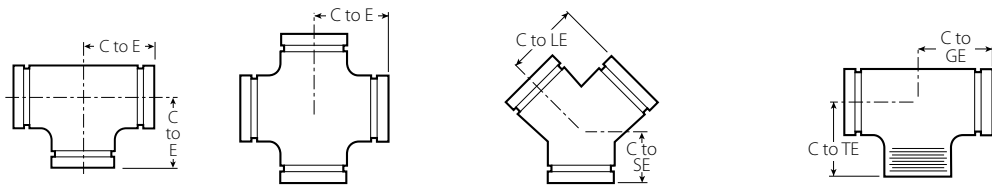

Size		No. 20 Tee		No. 35 Cross (sw)		No. 33 True Wye (sw)			No. 29M Tee with Threaded Branch		
Nominal inches DN	Actual Outside Diameter inches mm	C to E inches mm	Approx. Weight (Each) lb kg	C to E inches mm	Approx. Weight (Each) lb kg	C to LE inches mm	C to SE inches mm	Approx. Weight (Each) lb kg	C to GE inches mm	C to TE inches mm	Approx. Weight (Each) lb kg
3/4 DN20	1.050 26.9	2.25 57	0.6 0.3	2.25 57	0.9 0.4	2.25 57	2.00 51	0.7 0.3	2.25 57	2.25 (sw) 57	0.6 0.3
1 DN25	1.315 33.7	2.25 57	1.0 0.5	2.25 57	1.3 0.6	2.25 57	2.25 57	1.1 0.5	2.25 57	2.25 57	1.0 0.5
1 1/4 DN32	1.660 42.4	2.75 70	1.5 0.7	2.75 70	2.1 1.0	2.75 70	2.50 64	1.5 0.7	2.75 70	2.75 70	1.5 0.7
1 1/2 DN40	1.900 48.3	2.75 70	2.0 0.9	2.75 70	2.5 1.1	2.75 70	2.75 70	1.8 0.8	2.75 70	2.75 70	2.0 0.9
2 DN50	2.375 60.3	3.25 83	3.0 1.4	3.25 83	3.8 1.7	3.25 83	2.75 70	2.5 1.1	3.25 83	4.25 108	3.0 1.4
2 1/2 DN65	2.875 73.0	3.75 95	4.3 2.0	3.75 95	6.1 2.8	3.75 95	3.00 76	4.3 2.0	3.75 95	3.75 95	4.3 2.0
3 DN80	3.500 88.9	4.25 108	6.8 3.0	4.25 108	10.5 4.8	4.25 108	3.25 83	6.1 2.8	4.25 108	6.00 152	6.8 3.1
3 1/2 DN90	4.000 101.6	4.50 (sw) 114	7.9 3.6	4.50 114	11.5 5.2	4.50 114	3.50 89	9.6 4.4	4.50 114	4.50 (sw) 114	7.9 3.6
4 DN100	4.250 108.0	5.00 127	15.5 7.0	—	—	—	—	—	5.00 127	5.00 (sw) 127	15.5 7.0
4 DN100	4.500 114.3	5.00 127	11.9 5.4	5.00 127	15.8 7.2	5.00 127	3.75 95	9.8 4.4	5.00 127	7.25 184	11.9 5.4
5 DN125	5.000 127.0	5.25 (sw) 133	15.0 6.8	5.25 133	18.5 8.4	—	—	—	5.25 133	5.25 (sw) 133	15.0 6.8
5 DN125	5.250 133.0	5.50 140	17.8 8.1	—	—	—	—	—	5.50 140	5.50 (sw) 140	17.8 8.1
5 DN125	5.500 139.7	5.50 140	17.8 8.1	—	—	—	—	—	5.50 140	5.50 (sw) 140	17.8 8.1
5 DN125	5.563 141.3	5.50 140	17.8 8.1	5.50 140	20.0 9.1	5.50 140	4.00 102	15.0 6.8	5.50 140	5.50 (sw) 140	17.8 8.1
6 DN150	6.250 159.0	6.50 165	27.1 12.3	—	—	—	—	—	6.50 165	6.50 (sw) 165	27.1 12.3
6 DN150	6.500 165.1	6.50 165	22.0 10.0	6.50 165	28.0 12.7	—	—	—	6.50 165	6.50 (sw) 165	22.0 10.0
6 DN150	6.625 168.3	6.50 165	25.7 11.7	6.50 165	28.0 12.7	6.50 165	4.50 114	22.3 10.1	6.50 165	6.50 (sw) 165	25.7 11.7
8 DN200	8.625 219.1	7.75 197	47.6 21.6	7.75 197	48.0 21.8	7.75 197	6.00 152	36.0 16.3	7.75 197	7.75 197	47.6 21.6
10 DN250	10.750 273.0	9.00 229	99.0 44.9	9.00 229	121.5 55.1	9.00 229	6.50 155	69.9 31.7	9.00 229	9.00 229	99.0 44.9
12 DN300	12.750 323.9	10.00 254	133.0 60.3	10.00 254	110.0 49.9	10.00 254	7.00 178	80.0 36.3	10.00 254	10.00 254	133.0 60.3

(s) = Carbon Steel Direct Roll Groove (OGS)

(sw) = Carbon Steel Segmentally Welded

NOTE

- All fittings are ductile iron unless otherwise noted with an (sw) or (s).

4.3 DIMENSIONS (Continued)

Tees, Crosses and True Wyes

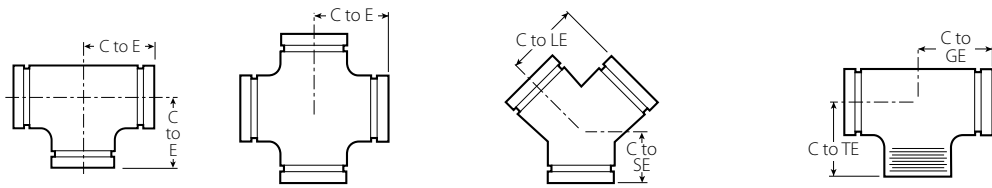

Size		No. 20 Tee		No. 35 Cross (sw)		No. 33 True Wye (sw)			No. 29M Tee with Threaded Branch		
Nominal inches DN	Actual Outside Diameter inches mm	C to E inches mm	Approx. Weight (Each) lb kg	C to E inches mm	Approx. Weight (Each) lb kg	C to LE inches mm	C to SE inches mm	Approx. Weight (Each) lb kg	C to GE inches mm	C to TE inches mm	Approx. Weight (Each) lb kg
14 ² DN350	14.000 355.6	11.00 (sw) 279	145.0 65.8	11.00 279	198.0 89.8	11.00 279	7.50 191	134.2 60.8	—	—	—
	377.0	11.50 292	145.0 65.8	—	—	—	—	—	—	—	—
16 ² DN400	16.000 406.4	12.00 (sw) 305	186.0 84.4	12.00 305	250.0 113.4	12.00 305	8.00 203	167.0 75.7	—	—	—
	426.0	13.00 300	186.0 84.4	—	—	—	—	—	—	—	—
18 ² DN450	18.000 457.0	15.50 (sw) 394	260.0 117.9	15.50 394	350.0 158.8	15.50 394	8.50 216	234.0 106.1	—	—	—
	480.0	14.63 372	256.0 116.1	—	—	—	—	—	—	—	—
20 ² DN500	20.000 508.0	17.25 (sw) 438	336.0 152.4	17.25 438	452.0 205.0	17.25 438	9.00 229	281.0 127.5	—	—	—
	530.0	15.38 (sw) 391	339.0 153.8	—	—	—	—	—	—	—	—
24 ² DN600	24.000 610.0	20.00 (sw) 508	592.0 268.5	20.00 508	795.0 360.6	20.00 508	10.00 254	523.0 237.2	—	—	—
	630.0	17.38 (sw) 441	473.0 214.5	—	—	—	—	—	—	—	—
14 – 60 DN350 – DN1500	For AGS fitting information, see publication 20.05 										

² For 14"/DN350 and larger roll grooved systems, Victaulic offers the Advanced Groove System (AGS). For pricing and availability of cut groove fittings in this size, contact your nearest Victaulic sales representative.

(s) = Carbon Steel Direct Roll Groove (OGS)

(sw) = Carbon Steel Segmentally Welded

NOTE

- All fittings are ductile iron unless otherwise noted with an (sw) or (s).

4.4 DIMENSIONS

Reducing Tee

No. 25 Grooved Branch

No. 29T Threaded Branch

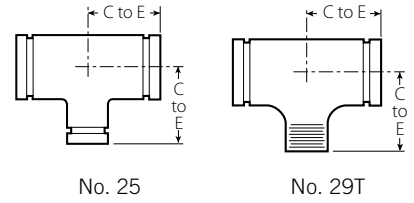
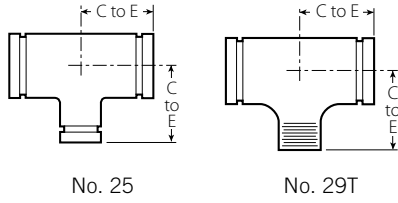

Size			No. 25 Std.	No. 29T w/ Thd. Branch	Approx. Weight (Each) lb kg	
Nominal inches DN			C to E inches mm	C to E inches mm		
1 DN25	x	1 DN25	2.25 (sw) 57	2.25 (sw) 57	1.0 0.5	
1 1/4 DN32	x	1 1/4 DN32	2.75 (sw) 70	2.75 (sw) 70	1.3 0.6	
1 1/2 DN40	x	1 1/2 DN40	3/4 DN20	2.75 (sw) 70	2.75 (sw) 70	1.5 0.7
			1 DN25	2.75 (sw) 70	2.75 (sw) 70	1.5 0.7
			1 1/4 DN32	2.75 (sw) 70	2.75 (sw) 70	1.7 0.8
2 DN50	x	2 DN50	3/4 DN20	3.25 83	3.25 83	2.5 1.1
			1 DN25	3.25 83	3.25 83	2.7 1.2
			1 1/4 DN32	3.25 (sw) 83	3.25 (sw) 83	1.8 0.8
			1 1/2 DN40	3.25 83	3.25 (sw) 83	3.0 1.4
2 1/2	x	2 1/2	3/4 DN20	3.75 (sw) 95	3.75 (sw) 95	3.9 1.8
			1 DN25	3.75 95	3.75 (sw) 95	3.8 1.7
			1 1/4 DN32	3.75 95	3.75 95	4.2 1.7
			1 1/2 DN40	3.75 95	3.75 95	3.9 1.8
			2 DN50	3.75 95	3.75 (sw) 95	4.5 2.0
3 DN80	x	3 DN80	3/4 DN20	4.25 (sw) 108	4.25 (sw) 108	5.7 2.6
			1 DN25	4.25 108	4.25 108	6.1 2.8
			1 1/4 DN32	4.25 108	4.25 108	8.0 3.6
			1 1/2 DN40	4.25 108	4.25 (sw) 108	6.5 2.9
			2 DN50	4.25 108	4.25 (sw) 108	6.2 2.8
			2 1/2	4.25 108	4.25 (sw) 108	6.4 2.9

Size			No. 25 Std.	No. 29T w/ Thd. Branch	Approx. Weight (Each) lb kg				
Nominal inches DN			C to E inches mm	C to E inches mm					
4 DN100	x	4 DN100	3/4 DN20	5.00 (sw) 127	5.00 (sw) 127	8.0 3.6			
			1 DN25	5.00 127	5.00 127	7.8 3.5			
			1 1/4 DN32	5.00 (sw) 127	5.00 (sw) 127	9.6 4.4			
			1 1/2 DN40	5.00 127	5.00 127	10.2 4.6			
			2 DN50	5.00 127	5.00 127	11.2 5.1			
			2 1/2	5.00 127	5.00 127	11.4 5.2			
			3 DN80	5.00 127	5.00 127	11.6 5.3			
			5	x	5	1 DN25	5.50 (sw) 140	5.50 (sw) 140	14.0 6.4
						1 1/2 DN40	5.50 (sw) 140	5.50 (sw) 140	14.3 6.5
						2 DN50	5.50 (sw) 140	5.50 (sw) 140	14.5 6.6
2 1/2	5.50 140	5.50 (sw) 140				15.2 6.9			
3 DN80	5.50 140	5.50 (sw) 140				16.6 7.5			
4 DN100	5.50 140	5.50 (sw) 140				16.7 7.6			
6 DN150	x	6 DN150	1 DN25	6.50 (sw) 165	6.50 (sw) 165	23.0 10.4			
			1 1/2 DN40	6.50 (sw) 165	6.50 (sw) 165	24.0 10.9			
			2 DN50	6.50 165	6.50 165	21.6 9.8			
			2 1/2	6.50 165	6.50 165	21.4 11.7			
			3 DN80	6.50 165	6.50 165	26.5 12.0			
			4 DN100	6.50 165	6.50 165	25.0 11.3			
6 1/2	x	6 1/2	3 DN80	6.50 165	6.50 (sw) 165	24.0 10.9			
			4 DN100	6.50 165	6.50 (sw) 165	25.0 11.3			

(s) = Carbon Steel Direct Roll Groove (OGS)

(sw) = Carbon Steel Segmentally Welded

NOTE

- Cast fitting available. Contact Victaulic for details.

(s) = Carbon Steel Direct Roll Groove (OGS)

(sw) = Carbon Steel Segmentally Welded

NOTE

- Cast fitting available. Contact Victaulic for details.

4.4 DIMENSIONS (Continued)

Reducing Tee

No. 25 Grooved Branch

No. 29T Threaded Branch

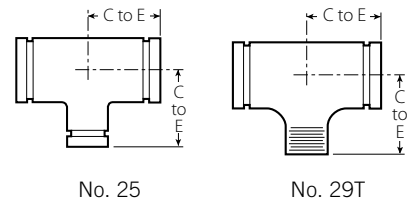
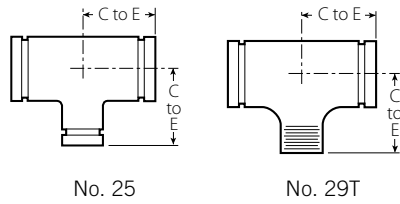

Size		No. 25 Std.	No. 29T w/ Thd. Branch	Approx. Weight (Each)	
Nominal inches DN		C to E inches mm	C to E inches mm	lb kg	
8 DN200 x 8 DN200	1 1/2 DN40	7.75 (sw) 197	7.75 (sw) 197	33.0 15.0	
	2 DN50	7.75 (sw) 197	7.75 (sw) 197	33.5 15.2	
	2 1/2	7.75 (sw) 197	7.75 (sw) 197	39.0 17.7	
	3 DN80	7.75 (sw) 197	7.75 (sw) 197	33.6 15.2	
	4 DN100	7.75 197	7.75 197	41.8 19.0	
	5	7.75 (sw) 197	7.75 (sw) 197	34.0 15.4	
	6 DN150	7.75 197	7.75 197	42.3 19.2	
	165.1mm	7.75 (sw) 197	7.75 (sw) 197	48.0 21.8	
	10 DN250 x 10 DN250	1 1/2 DN40	9.00 229	9.00 229	62.0 28.1
		2 DN50	9.00 (sw) 229	9.00 (sw) 229	62.0 28.1
2 1/2		9.00 (sw) 229	9.00 (sw) 229	62.4 28.3	
3 DN80		9.00 (sw) 229	9.00 (sw) 229	60.0 27.2	
4 DN100		9.00 (sw) 229	9.00 (sw) 229	61.0 27.7	
5		9.00 (sw) 229	9.00 (sw) 229	52.0 23.6	
6 DN150		9.00 (sw) 229	9.00 (sw) 229	59.0 26.8	
8 DN200		9.00 (sw) 229	9.00 (sw) 229	64.7 29.3	

(s) = Carbon Steel Direct Roll Groove (OGS)

(sw) = Carbon Steel Segmentally Welded

NOTE

- Cast fitting available. Contact Victaulic for details.

Size		No. 25 Std.	No. 29T w/ Thd. Branch	Approx. Weight (Each)	
Nominal inches DN		C to E inches mm	C to E inches mm	lb kg	
12 DN300 x 12 DN300	1 DN25	10.00 (sw) 254	10.00 (sw) 254	77.0 34.9	
	2 DN50	10.00 (sw) 254	10.00 (sw) 254	80.0 36.3	
	2 1/2	10.00 (sw) 254	10.00 (sw) 254	78.0 35.4	
	3 DN80	10.00 (sw) 254	10.00 (sw) 254	82.0 37.2	
	4 DN100	10.00 (sw) 254	10.00 (sw) 254	80.0 36.3	
	5	10.00 (sw) 254	10.00 (sw) 254	75.0 34.0	
	6 DN150	10.00 (sw) 254	10.00 (sw) 254	75.0 34.0	
	8 DN200	10.00 (sw) 254	10.00 (sw) 254	80.0 36.3	
	10 DN250	10.00 (sw) 254	10.00 (sw) 254	84.0 38.1	
	14 ² DN350 x 14 DN350	4 DN100	11.00 (sw) 279	11.00 (sw) 279	102.0 46.3
6 DN150		11.00 (sw) 279	11.00 (sw) 279	108.2 49.1	
8 DN200		11.00 279	11.00 279	112.0 50.8	
10 DN250		11.00 279	11.00 279	120.0 54.4	
12 DN300		11.00 279	11.00 279	129.1 58.6	
16 ² DN400 x 16 DN400		4 DN100	12.00 305	12.00 305	130.0 59.0
		6 DN150	12.00 (sw) 305	12.00 (sw) 305	133.5 60.6
		8 DN200	12.00 305	12.00 305	145.0 65.8
	10 DN250	12.00 305	12.00 305	149.5 67.8	
	12 DN300	12.00 305	12.00 305	154.0 69.9	
	14 DN350	12.00 (sw) 305	—	167.0 75.8	

² For 14"/DN350 and larger roll grooved systems, Victaulic offers the Advanced Groove System (AGS). For pricing and availability of cut groove fittings in this size, contact your nearest Victaulic sales representative.

(s) = Carbon Steel Direct Roll Groove (OGS)

(sw) = Carbon Steel Segmentally Welded

NOTE

- Cast fitting available. Contact Victaulic for details.

4.4 DIMENSIONS (Continued)

Reducing Tee

No. 25 Grooved Branch
 No. 29T Threaded Branch

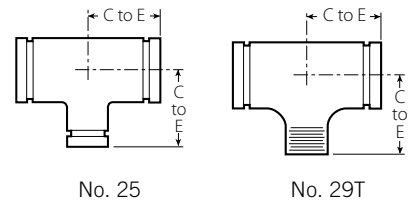
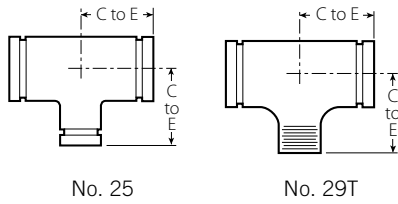

Size		No. 25 Std.	No. 29T w/ Thd. Branch	Approx. Weight (Each)			
Nominal inches	DN	C to E inches	C to E inches	lb			
		mm	mm	kg			
18 ² DN450	x 18 DN450	4 DN100	15.50 (sw) 394	15.50 (sw) 394	194.0 88.0		
		6 DN150	15.50 (sw) 394	15.50 (sw) 394	200.0 90.7		
		8 DN200	15.50 (sw) 394	15.50 (sw) 394	202.0 91.6		
		10 DN250	15.50 394	15.50 394	212.0 96.2		
		12 DN300	15.50 394	15.50 394	222.6 101.0		
		14 DN350	15.50 394	—	230.1 104.4		
		16 DN400	15.50 394	—	247.6 112.3		
		20 ² DN500	x 20 DN500	6 DN150	17.25 438	17.25 438	240.0 108.9
				8 DN200	17.25 438	17.25 438	244.0 110.7
				10 DN250	17.25 438	17.25 438	256.0 116.1
12 DN300	17.25 438			17.25 438	264.0 119.8		
14 DN350	17.25 438			—	275.0 124.7		
16 DN400	17.25 438			—	288.6 130.9		
18 DN450	17.25 438			—	297.0 134.7		

Size	No. 25 Std.	No. 29T w/ Thd. Branch	Approx. Weight (Each)		
Nominal inches	C to E inches	C to E inches	lb		
DN	mm	mm	kg		
24 ² DN600	x 24 DN600	8 DN200	20.00 508	20.00 508	340.0 154.2
		10 DN250	20.00 508	20.00 508	343.9 156.0
		12 DN300	20.00 508	20.00 508	352.8 160.0
		14 DN350	20.00 508	—	360.0 163.3
		16 DN400	20.00 508	—	378.0 171.5
		18 DN450	20.00 508	—	380.0 172.4
		20 DN500	20.00 508	—	373.0 169.2
		14 – 60 DN350 – 1500			For AGS fitting information, see publication 20.05

² For 14"/DN350 and larger roll grooved systems, Victaulic offers the Advanced Groove System (AGS). For pricing and availability of cut groove fittings in this size, contact your nearest Victaulic sales representative.

(s) = Carbon Steel Direct Roll Groove (OGS)
 (sw) = Carbon Steel Segmentally Welded

NOTES

- No. 29T Threaded Outlet Reducing Tees are supplied NPT and are available with British Standard threads. For British Standard specify "BSP" clearly on order.
- All fittings are ductile iron unless otherwise noted with an (sw) or (s).
- Cast fitting available. Contact Victaulic for details.

² For 14"/DN350 and larger roll grooved systems, Victaulic offers the Advanced Groove System (AGS). For pricing and availability of cut groove fittings in this size, contact your nearest Victaulic sales representative.

(s) = Carbon Steel Direct Roll Groove (OGS)
 (sw) = Carbon Steel Segmentally Welded

NOTE

- Cast fitting available. Contact Victaulic for details.

4.5 DIMENSIONS

Bull Plug

No. 61

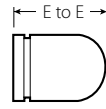

No. 61

Size		No. 61 Bull Plug (s)	
Nominal inches DN	Actual Outside Diameter inches mm	E to E inches mm	Approx. Weight (Each) lb kg
2 DN50	2.375 60.3	4.00 102	2.5 1.1
2 ½	2.875 73.0	5.00 127	3.0 1.4
3 DN80	3.500 88.9	6.00 152	4.5 2.0
4 DN100	4.500 114.3	7.00 178	7.5 3.4
5	5.563 141.3	8.00 203	12.0 5.4
6 DN150	6.625 168.5	10.00 254	17.0 7.7

(s) = Carbon Steel Direct Roll Groove (OGS)

(sw) = Carbon Steel Segmentally Welded

NOTES

- Steel dish caps available through 24"/DN600, contact Victaulic.
- No. 61 Bull Plugs should be used in vacuum service with Style 72 or 750 couplings.
- All fittings are ductile iron unless otherwise noted with an (sw) or (s).

4.6 DIMENSIONS

45° Lateral

No. 30

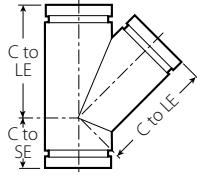

No. 30

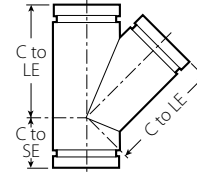

No. 30

Size		No. 30 45° Lateral		Weight
Nominal inches DN	Actual Outside Diameter inches mm	C to LE inches mm	C to SE inches mm	Approx. (Each) lb kg
¾ DN20	1.050 26.9	4.50 (sw) 114	2.00 (sw) 51	1.0 0.5
1 DN25	1.315 33.7	5.00 (sw) 127	2.25 (sw) 57	1.7 0.8
1¼ DN32	1.660 42.4	5.75 146	2.50 64	2.5 (d) 1.1
1½ DN40	1.900 48.3	6.25 (sw) 159	2.75 (sw) 70	3.5 1.6
2 DN50	2.375 60.3	7.00 (sw) 178	2.75 (sw) 70	5.0 2.3
2½	2.875 73.0	7.75 (sw) 197	3.00 (sw) 76	9.0 4.1
DN65	3.000 76.1	8.50 (sw) 216	3.25 (sw) 83	11.0 5.0
3 DN80	3.500 88.9	8.50 216	3.25 83	11.7 (d) 5.4
3½ DN90	4.000 101.6	10.00 (sw) 254	3.50 (sw) 89	17.8 8.1
4 DN100	4.500 114.3	10.50 267	3.75 95	22.2 (d) 10.1
5	5.563 141.3	12.50 (sw) 318	4.00 (sw) 102	21.8 9.9

(s) = Carbon Steel Direct Roll Groove (OGS)

(sw) = Carbon Steel Segmentally Welded

Size		No. 30 45° Lateral		Weight
Nominal inches DN	Actual Outside Diameter inches mm	C to LE inches mm	C to SE inches mm	Approx. (Each) lb kg
	6.500 165.1	14.00 (sw) 356	4.50 (sw) 114	43.6 19.8
6 DN150	6.625 168.3	14.00 (sw) 356	4.50 (sw) 114	43.6 19.8
8 DN200	8.625 219.1	18.00 (sw) 457	6.00 (sw) 152	72.0 32.7
10 DN250	10.750 273.0	20.50 (sw) 521	6.50 (sw) 165	105.0 47.6
12 DN300	12.750 323.9	23.00 (sw) 584	7.00 (sw) 178	165.0 74.8
14² DN350	14.000 355.6	26.50 (sw) 673	7.50 (sw) 191	276.0 125.2
16² DN400	16.000 406.4	29.00 (sw) 737	8.00 (sw) 203	344.2 156.1
18² DN450	18.000 457.0	32.00 (sw) 813	8.50 (sw) 216	429.0 194.6
20² DN500	20.000 508.0	35.00 (sw) 889	9.00 (sw) 229	500.0 226.8
24² DN600	24.000 610.0	40.00 (sw) 1016	10.00 (sw) 254	715.0 324.3
14 – 60 DN350 – DN1500	For AGS fitting information, see publication 20.05			



² For 14"/DN350 and larger roll grooved systems, Victaulic offers the Advanced Groove System (AGS). For pricing and availability of cut groove fittings in this size, contact your nearest Victaulic sales representative.

(s) = Carbon Steel Direct Roll Groove (OGS)

(sw) = Carbon Steel Segmentally Welded

NOTE

- All fittings are ductile iron unless otherwise noted with an (sw) or (s).

4.7 DIMENSIONS

45° Reducing Lateral

No. 30-R

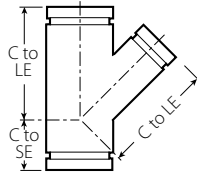

No. 30-R

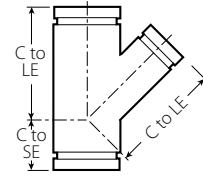

No. 30-R

Size			No 30-R 45° Reducing Lateral				
Nominal inches DN	x	Nominal inches DN	x	C to LE inches mm	C to SE inches mm	Approx. Weight (Each)	
						lb kg	
3 DN80	x	3 DN80	x	2 DN50	8.50 216	3.25 83	9.8 4.4
					2½	8.50 216	3.25 83
4 DN100	x	4 DN100	x	2 DN50	10.50 267	3.75 95	10.0 4.5
					2½	10.50 267	3.75 95
				3 DN80	10.50 267	3.75 95	18.3 8.3
5	x	5	x	2 DN50	12.50 318	4.00 102	24.0 10.9
				3 DN80	12.50 318	4.00 102	27.0 12.2
				4 DN100	12.50 318	4.00 102	26.5 12.0
6 DN150	x	6 DN150	x	3 DN80	14.00 356	4.50 114	37.0 16.8
				4 DN100	14.00 356	4.50 114	36.0 16.3
				5	14.00 356	4.50 114	44.7 20.3
8 DN200	x	8 DN200	x	4 DN100	18.00 457	6.00 152	62.0 28.1
				5	18.00 457	6.00 152	75.5 34.2
				6 DN150	18.00 457	6.00 152	82.0 37.2
10 DN250	x	10 DN250	x	4 DN100	20.50 521	6.50 165	104.8 47.5
				5	20.50 521	6.50 165	99.0 44.9
				6 DN150	20.50 521	6.50 165	105.8 48.0
				8 DN200	20.50 521	6.50 165	118.0 53.5
12 DN300	x	12 DN300	x	5	23.00 584	7.00 178	122.0 55.3
				6 DN150	23.00 584	7.00 178	137.0 62.1
				8 DN200	23.00 584	7.00 178	147.0 66.7
				10 DN250	23.00 584	7.00 178	167.0 75.8

Size			No 30-R 45° Reducing Lateral					
Nominal inches DN	x	Nominal inches DN	x	C to LE inches mm	C to SE inches mm	Approx. Weight (Each)		
						lb kg		
14 ² DN350	x	14 DN350	x	4 DN100	26.50 673	7.50 191	172.0 78.0	
					6 DN150	26.50 673	7.50 191	187.0 84.8
					8 DN200	26.50 673	7.50 191	205.8 93.4
					10 DN250	26.20 673	7.50 191	235.0 106.6
					12 DN300	26.50 673	7.50 191	250.0 113.4
16 ² DN400	x	16 DN400	x	6 DN150	29.00 737	8.00 203	215.0 97.5	
					8 DN200	29.00 737	8.00 203	252.5 114.5
					10 DN250	29.00 737	8.00 203	265.0 120.2
					12 DN300	29.00 737	8.00 203	295.0 133.8
					14 DN350	29.00 737	8.00 203	305.0 138.3
18 ² DN450	x	18 DN450	x	6 DN150	32.00 813	8.50 216	274.0 124.3	
					8 DN200	32.00 813	8.50 216	275.0 124.7
					12 DN300	32.00 813	8.50 216	347.0 157.4
					14 DN350	32.00 813	8.50 216	350.0 158.8
					16 DN400	32.00 813	8.50 216	362.0 164.2
20 ² DN500	x	20 DN500	x	12 DN300	35.00 889	9.00 229	415.0 188.2	
					14 DN350	35.00 889	9.00 229	420.0 190.5
					16 DN400	35.00 899	10.00 229	425.0 192.8
					20 DN600	40.00 1016	10.00 254	425.0 192.8
24 ² DN600	x	24 DN600	x	16 DN400	40.00 1016	10.00 254	425.0 192.8	
					20 DN600	40.00 1016	10.00 254	570.0 258.6
14 – 60 DN350 – DN1500				For AGS fitting information, see publication 20.05 				

² For 14"/DN350 and larger roll grooved systems, Victaulic offers the Advanced Groove System (AGS). For pricing and availability of cut groove fittings in this size, contact your nearest Victaulic sales representative.

4.8 DIMENSIONS

Tee Wye

No. 32

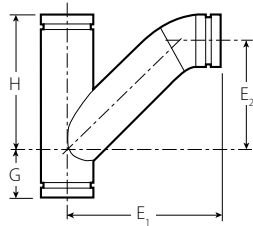

No. 32

Size			No. 32 Tee Wye (sw)				Approx. Weight (Each)		
Nominal inches DN			G inches mm	H inches mm	E ₁ inches mm	E ₂ inches mm			
2 DN50	x	2 DN50	x	2 DN50	2.75 70	7.00 178	9.00 229	4.63 118	6.4 2.9
2½	x	2½	x	2½	3.00 76	7.75 197	10.50 267	5.75 146	11.5 5.2
3 DN80	x	3 DN80	x	3 DN80	3.25 83	8.50 216	11.50 292	6.50 165	14.3 6.5
3½ DN90	x	3½ DN90	x	3½ DN90	3.25 89	10.00 254	13.00 330	7.75 197	22.9 10.4
4 100	x	4 DN100	x	4 DN100	3.75 95	10.50 267	13.63 346	8.13 207	26.0 11.8
5	x	5	x	5	4.00 102	12.50 318	16.13 410	10.00 254	48.0 21.8
6 DN150	x	6 DN150	x	6 DN150	4.50 114	14.00 356	18.25 464	11.50 292	60.5 27.4
8 DN200	x	8 DN200	x	8 DN200	6.00 152	18.00 457	23.25 591	15.25 387	127.1 57.7
10 DN250	x	10 DN250	x	10 DN250	6.50 165	20.50 521	27.25 692	18.00 457	190.0 86.2
12 DN300	x	12 DN300	x	12 DN300	7.00 178	23.00 584	31.00 787	20.50 521	240.0 108.9

(s) = Carbon Steel Direct Roll Groove (OGS)
 (sw) = Carbon Steel Segmentally Welded

4.9 DIMENSIONS

Adapter Nipple

No. 40¹² Grv. x Thd.

No. 42 Grv. x Bev.

No. 43 Grv. x Grv.

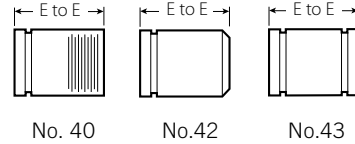

Size		No. 40, 42, 43 Adapter Nipple (s)	
Nominal inches DN	Actual Outside Diameter inches mm	E to E inches mm	Approx. Weight (Each) lb kg
¾ DN20	1.050 26.9	3.00 76	0.3 0.1
1 25	1.315 33.7	3.00 76	0.4 0.2
1¼ DN32	1.660 42.4	4.00 102	0.8 0.4
1½ 40	1.900 48.3	4.00 102	0.9 0.4
2 DN50	2.375 60.3	4.00 102	1.2 0.5
2½	2.875 73.0	4.00 102	1.9 0.9
3 DN80	3.500 88.9	4.00 102	2.5 1.1
3½ DN90	4.000 101.6	4.00 102	2.1 0.9
4 DN100	4.500 114.3	6.00 152	5.5 2.5
5	5.563 141.3	6.00 152	7.4 3.4
6 DN150	6.625 168.3	6.00 152	9.5 4.3
8 DN200	8.625 219.1	6.00 152	14.2 6.4
10 DN250	10.750 273.0	8.00 203	27.0 12.2
12 DN300	12.750 323.9	8.00 203	33.0 15.0

(s) = Carbon Steel Direct Roll Groove (OGS)
 (sw) = Carbon Steel Segmentally Welded

NOTES

- All fittings are ductile iron unless otherwise noted with an (sw) or (s).
- For pump package nipples with 1 ½"/40 mm hole cut to receive Style 923 Vic-Let or Style 924 Vic-O-Well request special No. 40, 42 or 43 nipples and specify No. 40-H, 42-H or 43-H on order. NOTE: 4 – 12"/DN100 – DN300 diameter — 8"/200mm minimum length required.
- For roll grooved systems, Victaulic offers the Advanced Groove System (AGS). For pricing and availability of cut groove fittings in this size, contact your nearest Victaulic sales representative.
- Available with British Standard Pipe Threads, specify "BSP" clearly on order.

4.10 DIMENSIONS

Cap

No. 60



No. 60



No. 60

Size		No. 60 Cap	
Nominal	Actual Outside Diameter	"T" Thickness	Approx. Weight (Each)
inches DN	inches mm	inches mm	lb kg
¾	1.050	0.88	0.2
DN20	26.9	22	0.1
1	1.315	0.88	0.3
25	33.7	22	0.1
1¼	1.660	0.88	0.3
DN32	42.4	22	0.1
1½	1.900	0.88	0.5
DN40	48.3	22	0.2
2	2.375	0.88	0.6
DN50	60.3	22	0.3
2½	2.875	0.88	1.0
	73.0	22	0.5
DN65	3.000	0.88	1.2
	76.1	22	0.5
3	3.500	0.88	1.2
DN80	88.9	22	0.5
3½	4.000	0.88	2.5
DN90	101.6	22	1.1
	4.250	1.00	2.3
	108.0	25	1.0
4	4.500	1.00	2.5
DN100	114.3	25	1.1
	5.250	1.00	4.5
	133.0	25	2.0
DN125	5.500	1.00	4.5
	139.7	25	2.0
5	5.563	1.00	4.6
	141.3	25	2.1

Size		No. 60 Cap	
Nominal	Actual Outside Diameter	"T" Thickness	Approx. Weight (Each)
inches DN	inches mm	inches mm	lb kg
	6.250	1.00	6.8
	159.0	25	3.1
	6.500	1.00	7.3
	165.1	25	3.3
6	6.625	1.00	6.1
DN150	168.3	25	2.8
8	8.625	1.19	13.1
DN200	219.1	30	5.9
10	10.750	1.25	21.0
DN250	273.0	32	9.5
12	12.750	1.25	35.6
DN300	323.9	32	16.2
14 ²	14.000	9.50 (s)	+
DN350	355.6	241	
16 ²	16.000	10.00 (s)	+
DN400	406.4	254	
18 ²	18.000	11.00 (s)	+
DN450	457.0	279	
20 ²	20.000	12.00 (s)	+
DN500	508.0	305	
24 ²	24.000	13.50 (s)	+
DN600	610.0	343	
14 – 60 DN350 – DN1500	For AGS fitting information, see publication 20.05		



² For 14"/DN350 and larger roll grooved systems, Victaulic offers the Advanced Groove System (AGS). For pricing and availability of cut groove fittings in this size, contact your nearest Victaulic sales representative.

(s) = Carbon Steel Direct Roll Groove (OGS)

(sw) = Carbon Steel Segmentally Welded

+ Contact Victaulic for details.

NOTES

- No. 60 cap is not suitable for use in vacuum service with Style 72 or 750 couplings. No. 61 bull plugs should be used.
- All fittings are ductile iron unless otherwise noted with an (sw) or (s).

4.11 DIMENSIONS

Flanged Adapter Nipple

No. 41 ANSI Class 125

No. 45F ANSI Class 150 Flat Face

No. 45R ANSI Class 150 Raised Face

No. 46F ANSI Class 300 Flat Face

No. 46R ANSI Class 300 Raised Face

No. 45RE PN10/PN16 Raised Face

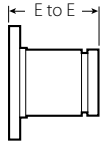

No. 41

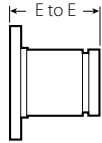

No. 45F

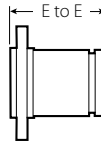

No. 45R

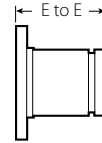

No. 46F

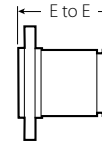

No. 46R

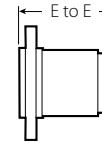

No. 45RE

Size		No. 41 ANSI 125 Flange Adapter Nipple		No. 45F and No. 45R ANSI 150 Flanged Adapter Nipple (s)		No. 46F and No. 46R ANSI 300 Flanged Adapter Nipple (s)		No. 45RE Flanged Adapter Nipple	
Nominal inches DN	Actual Outside Diameter inches mm	E to E inches mm	Approx. Weight (Each) lb kg	E to E inches mm	Approx. Weight (Each) lb kg	E to E inches mm	Approx. Weight (Each) lb kg	E to E inches mm	Approx. Weight (Each) lb kg
¾ DN20	1.050 26.9	3.00 76	—	3.00 76	2.3 1.0	3.00 76	3.3 1.5	—	—
1 DN25	1.315 33.7	3.00 76	2.5 1.1	3.00 76	2.7 1.2	3.00 76	3.9 1.8	—	—
1¼ DN32	1.660 42.4	4.00 102	3.0 1.4	4.00 102	3.3 1.5	4.00 102	4.8 2.2	—	—
1½ DN40	1.900 48.3	4.00 102	3.5 1.6	4.00 102	3.9 1.8	4.00 102	6.9 3.1	—	—
2 DN50	2.375 60.3	4.00 102	5.5 2.5	4.00 102	6.0 2.7	4.00 102	8.2 3.7	2.50 64	5.3 2.4
2½	2.875 73.0	4.00 102	8.0 3.6	4.00 102	9.9 4.5	4.00 102	11.9 5.4	—	—
DN65	3.000 76.1	—	—	—	—	—	—	2.50 64	6.5 2.9
3 DN80	3.500 88.9	4.00 102	9.5 4.3	4.00 102	11.7 5.3	4.00 102	16.5 7.5	2.50 64	8.2 3.7
3½ DN90	4.000 101.6	4.00 102	12.0 5.4	4.00 102	15.1 6.8	4.00 102	20.1 9.1	—	—
4 DN100	4.500 114.3	6.00 152	16.7 7.6	6.00 152	18.5 8.4	6.00 152	27.4 12.4	2.75 70	10.0 45
5	5.563 141.3	6.00 152	21.5 9.8	6.00 152	21.3 9.7	6.00 152	35.3 16.0	—	—
DN125	5.500 139.7	—	—	—	—	—	—	2.75 70	16.3 7.4
6 DN150	6.625 168.3	6.00 152	26.5 12.0	6.00 152	27.5 12.5	6.00 152	47.5 21.5	2.75 70	16.3 7.4
	6.500 165.1	—	—	—	—	—	—	—	—
8 DN200	8.625 219.1	6.00 152	39.0 17.7	6.00 152	41.3 18.8	6.00 152	70.3 31.9	—	—
10 DN250	10.750 273.0	8.00 203	57.0 25.9	8.00 203	59.3 27.1	8.00 203	100.8 45.7	—	—
12 DN300	12.750 323.9	8.00 203	41.0 18.6	8.00 203	40.0 40.0	8.00 203	146.2 66.3	—	—
14 ² DN350	14.000 355.6	8.00 203	—	8.00 203	+	8.00 203	+	—	—
16 ² DN400	16.000 406.4	8.00 203	—	8.00 203	+	8.00 203	+	—	—
18 ² DN450	18.000 457.0	8.00 203	—	8.00 203	+	8.00 203	+	—	—

² For 14"/DN350 and larger roll grooved systems, Victaulic offers the Advanced Groove System (AGS). For pricing and availability of cut groove fittings in this size, contact your nearest Victaulic sales representative.

(s) = Carbon Steel Direct Roll Groove (OGS)

(sw) = Carbon Steel Segmentally Welded

4.11 DIMENSIONS (Continued)

Flanged Adapter Nipple

No. 41 ANSI Class 125

No. 45F ANSI Class 150 Flat Face

No. 45R ANSI Class 150 Raised Face

No. 46F ANSI Class 300 Flat Face

No. 46R ANSI Class 300 Raised Face

No. 45RE PN10/PN16 Raised Face

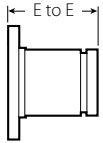

No. 41

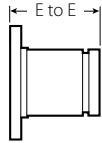

No. 45F

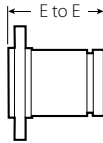

No. 45R

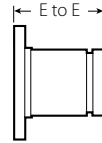

No. 46F

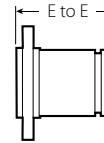

No. 46R

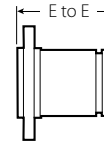

No. 45RE

Size		No. 41 ANSI 125 Flange Adapter Nipple		No. 45F and No. 45R ANSI 150 Flanged Adapter Nipple (s)		No. 46F and No. 46R ANSI 300 Flanged Adapter Nipple (s)		No. 45RE Flanged Adapter Nipple (s)	
Nominal inches DN	Actual Outside Diameter inches mm	E to E inches mm	Approx. Weight (Each) lb kg	E to E inches mm	Approx. Weight (Each) lb kg	E to E inches mm	Approx. Weight (Each) lb kg	E to E inches mm	Approx. Weight (Each) lb kg
20 ² DN500	20.000 508.0	8.00 203	—	8.00 203	+	8.00 203	+	—	—
24 ² DN600	24.000 610.0	8.00 203	—	8.00 203	+	8.00 203	+	—	—
14 – 60 DN350 – DN1500	For AGS fitting information, see publication 20.05 								

² For 14"/DN350 and larger roll grooved systems, Victaulic offers the Advanced Groove System (AGS). For pricing and availability of cut groove fittings in this size, contact your nearest Victaulic sales representative.

(s) = Carbon Steel Direct Roll Groove (OGS)

(sw) = Carbon Steel Segmentally Welded

+ Contact Victaulic for details

NOTE

- All fittings are ductile iron unless otherwise noted with an (sw) or (s).

4.12 DIMENSIONS

Swaged Nipple

No. 53 Grv. x Grv.

No. 54 Grv. x Thd.

No. 55 Thd. x Grv.

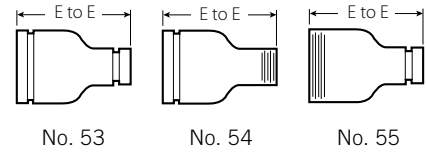
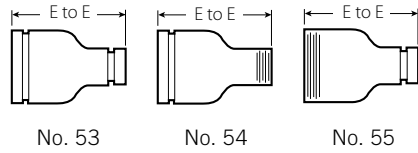

Size			No. 53, 54, and 55 Swaged Nipples (s)	
Nominal inches DN			E to E inches mm	Approx. Weight (Each) lb kg
2 DN50	x	1 DN25	6.50 165	2.0 0.9
		1¼ DN32	6.50 165	2.0 0.9
		1½ DN40	6.50 165	2.0 0.9
2½	x	1 DN25	7.00 178	3.0 1.4
		1¼ DN32	7.00 178	3.0 1.4
		1½ DN40	7.00 178	3.0 1.4
		2 DN50	7.00 178	3.0 1.4
3 DN80	x	1 DN25	8.00 203	4.5 2.0
		1¼ DN32	8.00 203	4.5 2.0
		1½ DN40	8.00 203	4.5 2.0
		2 DN50	8.00 203	4.5 2.0
		2½	8.00 203	4.5 2.0
3½ DN90	x	3 DN80	8.00 203	6.8 3.1
4 DN100	x	1 DN25	9.00 229	7.5 3.4
		1¼ DN32	9.00 229	7.5 3.4
		1½ DN40	9.00 229	7.5 3.4
		2 DN50	9.00 229	7.5 3.4
		2½	9.00 229	7.5 3.4
		3 DN80	9.00 229	7.5 3.4
		3½ DN90	9.00 229	7.5 3.4

Size			No. 53, 54, and 55 Swaged Nipples (s)	
Nominal inches DN			E to E inches mm	Approx. Weight (Each) lb kg
5	x	2 DN50	11.00 279	11.5 5.2
		3 DN80	11.00 279	11.3 5.1
		4 DN100	11.00 279	11.5 5.2
6 DN150	x	1 DN25	12.00 305	17.0 7.7
		1¼ DN32	12.00 305	17.0 7.7
		1½ DN40	12.00 305	17.2 7.8
		2 DN50	12.00 305	17.4 7.9
		2½	12.00 305	17.4 7.9
		3 DN80	12.00 305	17.4 7.9
		3½ DN90	12.00 305	17.4 7.9
		4 DN100	12.00 305	17.5 7.9
		4½	12.00 305	17.5 7.9
		5	12.00 305	17.5 7.9
		8 DN200	x	6 DN150

(s) = Carbon Steel Direct Roll Groove (OGS)

(sw) = Carbon Steel Segmentally Welded

+ Contact Victaulic for details

NOTE

- All fittings are ductile iron unless otherwise noted with an (sw) or (s).

4.13 DIMENSIONS

Female Threaded Adapter

No. 80

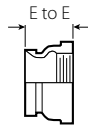

No. 80

Size		No. 80 Female Threaded Adapter	
Nominal inches DN	Actual Outside Diameter inches mm	E to E inches mm	Approx. Weight (Each) lb kg
¾ DN20	1.050 26.9	2.00 51	1.0 0.5
1 DN25	1.315 33.7	2.06 52	1.0 0.5
1¼ DN32	1.660 42.4	2.31 (sw) 59	1.5 0.7
1½ DN40	1.900 48.3	2.31 (sw) 59	1.5 0.7
2 DN50	2.375 60.3	2.50 64	1.4 0.6
2½	2.875 73.0	2.75 70	1.5 0.7
3 DN80	3.500 88.9	2.75 70	2.9 1.3
4 DN100	4.500 114.3	3.25 83	4.5 2.0

(s) = Carbon Steel Direct Roll Groove (OGS)

(sw) = Carbon Steel Segmentally Welded

NOTES

- Available with British Standard Pipe Threads, specify "BSP" clearly on order.
- All fittings are ductile iron unless otherwise noted with an (sw) or (s).

4.14 DIMENSIONS

Hose Nipple

No. 48

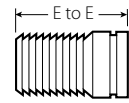

No. 48

Size		No. 48 Hose Nipple (s)	
Nominal inches DN	Actual Outside Diameter inches mm	E to E inches mm	Approx. Weight (Each) lb kg
¾ DN20	1.050 26.9	3.12 79	0.3 0.1
1 DN25	1.315 33.7	3.38 86	0.4 0.2
1¼ DN32	1.660 42.4	3.88 98	0.6 0.3
1½ DN40	1.900 48.3	3.88 98	0.8 0.4
2 DN50	2.375 60.3	4.50 114	1.1 0.5
2½	2.875 73.0	5.38 137	2.0 0.9
3 DN80	3.500 88.9	5.75 146	3.2 1.5
4 DN100	4.500 114.3	7.00 178	4.9 2.2
5	5.563 141.3	8.75 222	8.0 3.6
6 DN150	6.625 168.3	10.13 257	14.3 6.5
8 DN200	8.625 219.1	11.88 302	24.7 11.2
10 DN250	10.750 273.0	12.50 318	40.1 18.2
12 DN300	12.750 323.9	14.50 368	62.0 28.1

(s) = Carbon Steel Direct Roll Groove (OGS)

(sw) = Carbon Steel Segmentally Welded

NOTE

- All fittings are ductile iron unless otherwise noted with an (sw) or (s).

4.15 DIMENSIONS

Concentric/Eccentric Reducer

No. 50 Concentric

No. 51 Eccentric

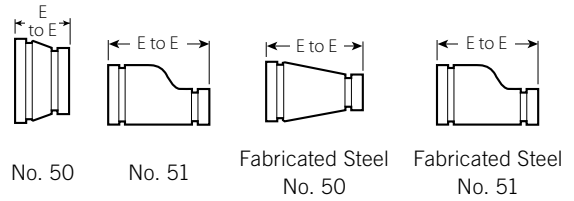
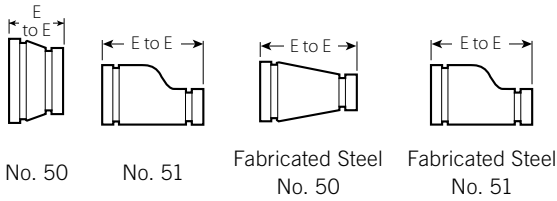

Size	No. 50 Concentric Reducer			No. 51 Eccentric Reducer	
	Nominal inches DN	E to E inches mm	Approx. Weight (Each) lb kg	E to E inches mm	Approx. Weight (Each) lb kg
1 1/4 DN32 x 3/4 DN20	+	1.9 0.9	—	—	
	1 DN25	+	1.9 0.9	—	—
1 1/2 DN40 x 3/4 DN20	+	1.4 0.6	—	—	
	1 DN25	2.50 64	0.8 0.4	8.50 (sw) 216	4.5 2.0
	1 1/4 DN32	2.50 64	1.0 0.5	—	—
2 DN50 x 3/4 DN20	2.50 64	0.9 0.3	9.00 (sw) 229	2.0 0.9	
	1 DN25	2.50 64	0.7 0.3	9.00 (sw) 229	2.3 1.0
	1 1/4 DN32	2.50 64	1.2 0.5	9.00 (sw) 229	4.6 2.1
	1 1/2 DN40	2.50 64	1.0 0.5	3.50 89	1.1 0.5
2 1/2 x 3/4 DN20	+	1.3 0.6	+	3.3 1.5	
	1 DN25	2.50 64	1.1 0.5	9.50 241	3.5 1.6
	1 1/4 DN32	3.50 89	3.3 1.5	3.50 89	1.4 0.6
	1 1/2 DN40	2.50 64	3.6 1.6	9.50 (sw) 241	3.7 1.7
	2 DN50	2.50 64	3.9 1.8	3.50 89	4.3 2.0
3 DN80 x 3/4 DN20	+	1.5 0.7	+	4.5 2.0	
	1 DN25	2.50 64	1.3 0.6	9.50 (sw) 241	4.8 2.2
	1 1/4 DN32	2.50 64	1.4 0.6	+	4.8 2.2
	1 1/2 DN40	2.50 64	5.1 2.3	9.50 (sw) 241	5.1 2.3
	2 DN50	2.50 64	1.6 0.7	3.50 89	6.0 2.7
	2 1/2	2.50 64	1.8 0.8	3.50 89	7.0 3.2
3 1/2 DN90 x 3 DN80	2.50 64	2.0 0.9	9.50 (sw) 241	7.0 3.2	
	4 DN100 x 1 DN25	3.00 76	3.0 1.4	13.00 (sw) 330	6.5 2.9

Size	No. 50 Concentric Reducer			No. 51 Eccentric Reducer	
	Nominal inches DN	E to E inches mm	Approx. Weight (Each) lb kg	E to E inches mm	Approx. Weight (Each) lb kg
5	1 1/4 DN32	+	4.6 2.1	—	—
	1 1/2 DN40	3.00 (sw) 76	2.6 1.2	10.00 (sw) 254	8.1 3.7
	2 DN50	3.00 76	2.4 1.1	4.00 102	3.3 1.5
	2 1/2	3.00 76	2.7 1.2	4.00 102	3.4 1.5
	3 DN80	3.00 76	3.2 1.4	4.00 102	3.5 1.6
	3 1/2 DN90	3.00 76	2.9 1.3	10.00 (sw) 254	8.0 3.6
	5 x 2 DN50	11.00 (sw) 279	9.0 4.1	11.00 (sw) 279	5.2 2.4
2 1/2		4.00 102	4.3 2.0	11.00 (sw) 279	10.8 4.9
3 DN80		4.00 102	5.5 2.5	11.00 (sw) 279	11.1 5.0
4 DN100		3.50 89	4.3 1.9	5.00 127	12.0 5.4
6 DN150 x 1 DN25	4.00 102	5.0 2.3	11.50 (sw) 292	14.5 6.6	
	1 1/2 DN40	+	5.5 2.5	+	+
	2 DN50	4.00 102	6.6 3.0	11.50 (sw) 292	14.5 6.6
	2 1/2	4.00 102	6.4 2.9	11.50 (sw) 292	14.2 6.4
	3 DN80	4.00 102	6.4 2.9	5.50 140	15.0 6.8
	4 DN100	4.00 102	6.5 2.9	5.50 140	17.0 7.7
	5	4.00 102	6.4 2.9	5.50 140	17.0 7.7
8 DN200 x 2 1/2	16.00 406	7.9 3.6	12.00 (sw) 305	26.1 11.8	
	3 DN80	5.00 127	9.3 4.2	12.00 (sw) 305	22.0 10.0
	4 DN100	5.00 127	10.4 4.8	12.00 (sw) 305	23.0 10.4
	5	5.00 127	11.6 5.2	12.00 (sw) 305	23.0 10.4
	6 DN150	5.00 127	11.9 5.4	6.00 152	24.0 10.9

4.15 DIMENSIONS (Continued)

Concentric/Eccentric Reducer

No. 50 Concentric

No. 51 Eccentric

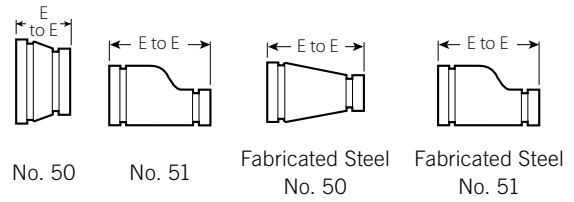
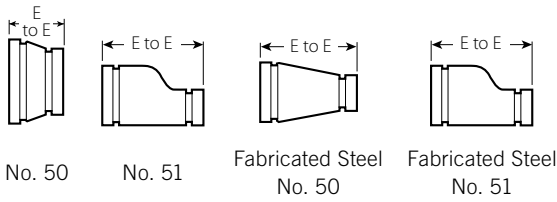

Size		No. 50 Concentric Reducer		No. 51 Eccentric Reducer	
Nominal inches DN	E to E inches mm	Approx. Weight (Each) lb kg	E to E inches mm	Approx. Weight (Each) lb kg	
10 DN250 ^x	4 DN100	19.7 8.9	13.00 (sw) 330	32.0 14.5	
	5	+ 15.0	+	34.6 15.7	
	6 DN150	20.0 9.1	13.00 (sw) 330	36.9 16.7	
	8 DN200	22.0 10.0	7.00 178	21.6 9.8	
12 DN300 ^x	4 DN100	44.0 20.0	14.00 (sw) 356	48.0 21.8	
	6 DN150	24.6 11.2	14.00 (sw) 356	50.0 22.7	
	8 DN200	52.0 23.6	14.00 (sw) 356	53.5 24.3	
	10 DN250	39.0 17.7	14.00 (sw) 356	57.0 25.9	
14 ² DN350 ^x	6 DN150	65.0 29.5	13.00 330	60.0 27.2	
	8 DN200	65.0 29.5	13.00 330	60.0 27.2	
	10 DN250	66.0 29.9	13.00 330	65.0 29.5	
	12 DN300	68.0 30.8	13.00 330	66.0 29.9	
	14 DN350	73.0 33.1	14.00 355	73.0 33.1	
16 ² DN400 ^x	8 DN200	73.0 33.1	14.00 355	73.0 33.1	
	10 DN250	73.0 33.1	14.00 355	73.0 33.1	
	12 DN300	73.0 33.1	14.00 355	73.0 33.1	
	14 DN350	73.0 33.1	14.00 355	73.0 33.1	
18 ² DN450 ^x	10 DN250	91.0 41.3	15.00 381	91.0 41.3	
	12 DN300	91.0 41.3	15.00 381	91.0 41.3	
	14 DN350	91.0 41.3	15.00 381	91.0 41.3	
	16 DN400	91.0 41.3	15.00 381	91.0 41.3	

Size		No. 50 Concentric Reducer		No. 51 Eccentric Reducer	
Nominal inches DN	E to E inches mm	Approx. Weight (Each) lb kg	E to E inches mm	Approx. Weight (Each) lb kg	
20 ² DN500 ^x	10 DN250	110.0 49.9	20.00 508	20.00 508	177.0 80.3
	12 DN300	120.0 54.4	20.00 508	20.00 508	120.0 54.4
	14 DN350	149.0 67.9	20.00 508	20.00 508	149.0 67.9
	16 DN400	120.0 54.4	20.00 508	20.00 508	120.0 54.4
	18 DN450	136.0 61.7	20.00 508	20.00 508	136.0 61.7
24 ² DN600 ^x	10 DN250	142.0 64.4	20.00 508	20.00 508	142.0 64.4
	12 DN300	150.0 68.0	20.00 508	20.00 508	150.0 68.0
	14 DN350	162.0 73.5	20.00 508	20.00 508	162.0 73.5
	16 DN400	162.0 73.5	20.00 508	20.00 508	162.0 73.5
	18 DN450	162.0 73.5	20.00 508	20.00 508	162.0 73.5
	20 DN500	151.0 68.5	20.00 508	20.00 508	190.0 86.2
14 – 60 DN350 – DN1500	For AGS fitting information, see publication 20.05				



² For 14"/DN350 and larger roll grooved systems, Victaulic offers the Advanced Groove System (AGS). For pricing and availability of cut groove fittings in this size, contact your nearest Victaulic sales representative.

(s) = Carbon Steel Direct Roll Groove (OGS)

(sw) = Carbon Steel Segmentally Welded

+ Contact Victaulic for details.

NOTES

- Available with male threaded small end No. 52.
- Cast fitting available for JIS size. Contact Victaulic for details.
- Steel eccentric reducers available through 30"/DN750, contact Victaulic for dimensions.
- All fittings are ductile iron unless otherwise noted with an (sw) or (s).

² For 14"/DN350 and larger roll grooved systems, Victaulic offers the Advanced Groove System (AGS). For pricing and availability of cut groove fittings in this size, contact your nearest Victaulic sales representative.

4.16 DIMENSIONS

Small Threaded Reducer

No. 52

No. 52F



No. 52

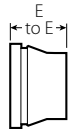

No. 52F



No. 52



No. 52F

Size		No. 52 Small Threader Reducer		No. 52F Concentric Reducer with BSPT Female Threaded End	
Nominal inches DN		E to E inches mm	Approx. Weight (Each) lb kg	E to E mm	Approx. Weight (Each) kg
1½ DN40	x 1 DN25	2.50 64	0.8 0.4	—	—
	x 1¼ DN32	2.50 64	0.9 0.4	—	—
2 DN50	x ¾ DN20	2.50 64	0.9 0.4	—	—
	x 1 DN25	2.50 64	0.7 0.3	—	—
	x 1¼ DN32	2.50 64	1.2 0.5	—	—
	x 1½ DN40	2.50 64	1.0 0.5	—	—
2½	x 1 DN25	2.50 64	1.1 0.5	—	—
	x 1¼ DN32	2.50 (sw) 64	1.2 0.5	—	—
	x 1½ DN40	2.50 (sw) 64	1.3 0.6	—	—
	x 2 DN50	2.50 64	1.4 0.6	—	—
DN65	x 1½ DN40	64	0.8	64	0.8
	x 2 DN50	—	—	64	0.9
3 DN80	x ¾ DN20	+(sw)	1.5 0.7	—	—
	x 1 DN25	2.50 64	1.3 0.6	—	—
	x 1¼ DN32	2.50 64	1.5 0.7	—	—
	x 1½ DN40	2.50 (sw) 64	1.5 0.7	—	—
	x 2 DN50	2.50 64	1.5 0.7	—	—
	x 2½	2.50 64	2.4 1.1	—	—
88.9mm	x 42.4mm	64	0.9	64	0.8
	x 48.3mm	64	0.9	64	0.9
	x 60mm	—	—	64	0.9

(s) = Carbon Steel Direct Roll Groove (OGS)

(sw) = Carbon Steel Segmentally Welded

+ Contact Victaulic for details.

Size		No. 52 Small Threader Reducer		No. 52F Concentric Reducer with BSPT Female Threaded End	
Nominal inches DN		E to E inches mm	Approx. Weight (Each) lb kg	E to E mm	Approx. Weight (Each) kg
4 DN100	x 1 DN25	3.00 76	2.3 1.0	—	—
	x 1½ DN40	3.00 76	2.7 1.2	—	—
	x 2 DN50	3.00 76	2.6 1.2	—	—
	x 2½	3.00 76	2.6 1.2	—	—
	x 3 DN80	3.00 76	2.5 1.1	—	—
108.0mm	x 42.4mm	76	1.3	76	1.3
	x 48.3mm	76	1.3	76	1.4
	x 60mm	—	—	76	1.4
114.3mm	x 42.4mm	76	1.3	76	1.3
	x 48.3mm	76	1.3	76	1.3
	x 60mm	76	1.3	76	1.4
5	x 4 DN100	+	4.5 2.0	—	—
	x 60mm	—	—	114	2.2
139.0mm	x 60mm	—	—	114	2.3
6 DN150	x 1 DN25	4.00 102	5.5 2.5	—	—
	x 2 DN50	4.00 102	5.7 2.6	—	—
	x 2½	4.00 102	5.8 2.6	—	—
	x 3 DN80	4.00 102	5.8 2.6	—	—
	x 4 DN100	+(sw)	6.5 2.9	—	—
159.0mm	x 42.4mm	114	2.2	144	2.5
	x 48.3mm	114	2.2	114	2.5
	x 60mm	—	—	114	2.6

4.16 DIMENSIONS (Continued)

Small Threaded Reducer

No. 52

No. 52F



No. 52



No 52F

Size	No. 52 Small Threader Reducer		No. 52F Concentric Reducer with BSPT Female Threaded End		
	Nominal inches DN	E to E inches mm	Approx. Weight (Each) lb kg	E to E mm	Approx. Weight (Each) kg
165.1mm x 42.4mm	48.3mm	102mm	2.4	102	2.9
	60mm	—	—	102	3.0
	8 DN200 x 2 DN50	16.00 406	1.5 0.7	—	—
	2 1/2	16.00 406	1.7 0.8	—	—

(s) = Carbon Steel Direct Roll Groove (OGS)

(sw) = Carbon Steel Segmentally Welded

NOTES

- Available with British Standard Pipe Threads, specify “BSP” clearly on order.
- All fittings are ductile iron unless otherwise noted with an (sw) or (s).

5.0 PERFORMANCE

Flow Data

(Frictional Resistance)

The chart expresses the frictional resistance of various Victaulic fittings as equivalent feet of straight pipe. Fittings not listed can be estimated from the data given, for example, a 22½° elbow is approximately one-half the resistance of a 45° elbow. Values of mid-sizes can be interpolated.

Size		Dimensions					
Nominal inches DN	Actual Outside Diameter inches mm	90° Elbows		45° Elbows		Tees	
		No. 10 Std. Radius feet meters	No. 100 1 ½ D Long Radius feet meters	No. 11 Std. Radius feet meters	No. 110 1 ½ D Long Radius feet meters	Branch feet meters	Run feet meters
1 DN25	1.315 33.7	1.7 0.5	—	0.8 0.2	—	4.2 1.3	1.7 0.5
2 DN50	2.375 60.3	3.5 1.1	2.5 0.8	1.8 0.5	1.1 0.3	8.5 2.6	3.5 1.1
DN65	3.000 76.1	4.3 1.3	—	2.1 0.7	—	10.8 3.3	4.3 1.3
3 DN80	3.500 88.9	5.0 1.5	3.8 1.2	2.6 0.8	1.6 0.5	13.0 4.0	5.0 1.5
	4.250 108.0	6.4 2.0	—	3.2 0.9	—	15.3 4.7	6.4 2.0
4 DN100	4.500 114.3	6.8 2.1	5.0 1.5	3.4 1.0	2.1 0.6	16.0 4.9	6.8 2.1
	5.250 133.0	8.1 2.5	—	4.1 1.2	—	20.0 6.2	8.1 2.5
DN125	5.500 139.7	8.5 2.6	—	4.2 1.3	—	21.0 6.4	8.5 2.6
5	5.563 141.3	8.5 2.6	—	4.2 1.3	—	21.0 6.4	8.5 2.6
	6.250 159.0	9.4 2.9	—	4.9 1.5	—	25.0 7.6	9.6 2.9
	6.500 165.1	9.6 2.9	—	5.0 1.5	—	25.0 7.6	10.0 3.0
6 DN150	6.625 168.3	10.0 3.0	7.5 2.3	5.0 1.5	3.0 0.9	25.0 7.6	10.0 3.0
8 DN200	8.625 219.1	13.0 4.0	9.8 3.0	6.5 2.0	4.0 1.2	33.0 10.1	13.0 4.0
10 DN250	10.750 273.0	17.0 5.2	12.0 3.7	8.3 2.5	5.0 1.5	41.0 12.5	17.0 5.2
12 DN300	12.750 323.9	20.0 6.1	14.5 4.4	10.0 3.0	6.0 1.8	50.0 15.2	20.0 6.1
14 DN350	14.000 355.6	24.5 ⁴ 7.5	15.8 4.8	18.5 ⁴ 5.6	11.0 3.4	70.0 21.3	23.0 7.0
16 DN400	16.000 406.4	28.0 ⁴ 8.5	18.0 5.5	21.0 ⁴ 6.4	13.0 4.0	80.0 24.4	27.0 8.2
18 DN450	18.000 457.0	31.0 ⁴ 9.5	20.0 6.1	23.5 ⁴ 7.2	14.0 4.3	90.0 27.4	30.0 9.1
20 DN800	20.000 508.0	34.0 ⁴ 10.4	22.5 6.9	25.5 ⁴ 7.8	16.0 4.9	100.0 30.5	33.0 10.1
24 DN600	24.000 610.0	42.0 ⁴ 12.8	27.0 8.2	29.5 ⁴ 9.0	19.0 5.8	120.0 36.6	40.0 12.2

AGS fittings available up to 60"/DN1500. Contact Victaulic for details.



⁴ Fitting flow data for 14-24"/DN350-DN600 size No. 10 and No. 11 Elbows is based on fittings for Style 07 and 77 couplings. For flow data on AGS fittings (No. W10 and No. W11 Elbows), refer to [publication 20.05](#).

User Responsibility for Product Selection and Suitability

Each user bears final responsibility for making a determination as to the suitability of Victaulic products for a particular end-use application, in accordance with industry standards and project specifications, and the applicable building codes and related regulations as well as Victaulic performance, maintenance, safety, and warning instructions. Nothing in this or any other document, nor any verbal recommendation, advice, or opinion from any Victaulic employee, shall be deemed to alter, vary, supersede, or waive any provision of Victaulic Company's standard conditions of sale, installation guide, or this disclaimer.

Intellectual Property Rights

No statement contained herein concerning a possible or suggested use of any material, product, service, or design is intended, or should be construed, to grant any license under any patent or other intellectual property right of Victaulic or any of its subsidiaries or affiliates covering such use or design, or as a recommendation for the use of such material, product, service, or design in the infringement of any patent or other intellectual property right. The terms "Patented" or "Patent Pending" refer to design or utility patents or patent applications for articles and/or methods of use in the United States and/or other countries.

Note

This product shall be manufactured by Victaulic or to Victaulic specifications. All products to be installed in accordance with current Victaulic installation/assembly instructions. Victaulic reserves the right to change product specifications, designs and standard equipment without notice and without incurring obligations.

Installation

Reference should always be made to the Victaulic installation handbook or installation instructions of the product you are installing. Handbooks are included with each shipment of Victaulic products, providing complete installation and assembly data, and are available in PDF format on our website at www.victaulic.com.

Warranty

Refer to the Warranty section of the current Price List or contact Victaulic for details.

Trademarks

Victaulic and all other Victaulic marks are the trademarks or registered trademarks of Victaulic Company, and/or its affiliated entities, in the U.S. and/or other countries.

FIG. 3205

Straight Tee

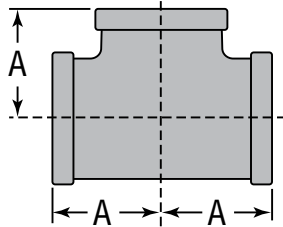

For Listings/Approval Details and Limitations, visit our website at www.anvilintl.com or contact an Anvil® Sales Representative.

FIGURE 3205 - STRAIGHT TEE

Nominal Size	Maximum Working Pressure [▲]	Dimension A	Approx. Wt. Each
<i>In. (mm)</i>	<i>PSI (kPa)</i>	<i>In. (mm)</i>	<i>Lbs. (kg)</i>
1 <i>25</i>	500 <i>3450</i>	1.50 <i>38.10</i>	0.85 <i>0.39</i>
1¼ <i>32</i>	500 <i>3450</i>	1.75 <i>44.45</i>	1.22 <i>0.55</i>
1½ <i>40</i>	500 <i>3450</i>	1.94 <i>49.27</i>	1.55 <i>0.70</i>
2 <i>50</i>	500 <i>3450</i>	2.25 <i>57.15</i>	2.45 <i>1.11</i>

▲ – Working Pressure Ratings are for reference only and based on Sch. 40 pipe. For the latest UL/ULC, and FM pressure ratings versus pipe schedule, please visit [anvilintl.com](http://www.anvilintl.com) or contact your local Anvil Representative.

MATERIAL SPECIFICATIONS

Dimensions: ASME B16.3

Material: ASTM A536 Grade 65-45-12

Finish: Black

Threads: NPT per ASME B1.20.1

Agency Approvals: All ductile iron threaded fittings are UL/ULC Listed and FM Approved.

NOTICE: Ductile iron fittings have higher tensile strength than that of steel pipe. Therefore, over tightening can cause damage to pipe threads which may cause leakage. Ductile iron fittings should be tightened approximately three turns beyond hand tight, but no more than four turns.

PROJECT INFORMATION

APPROVAL STAMP

Project:	<input type="checkbox"/> Approved
Address:	<input type="checkbox"/> Approved as noted
Contractor:	<input type="checkbox"/> Not approved
Engineer:	Remarks:
Submittal Date:	
Notes 1:	
Notes 2:	

FIG. 3221R

Reducing Coupling

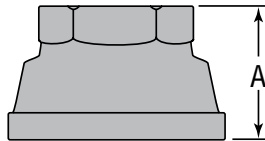

For Listings/Approval Details and Limitations, visit our website at www.anvilintl.com or contact an Anvil® Sales Representative.

FIGURE 3221R - REDUCING COUPLING			
Nominal Size	Maximum Working Pressure▲	Dimension A	Approx. Wt. Each
<i>In. (mm)</i>	<i>PSI (kPa)</i>	<i>In. (mm)</i>	<i>Lbs. (kg)</i>
1 x 1/2 <i>25 x 15</i>	500 <i>3450</i>	1.69 <i>42.92</i>	0.39 <i>0.18</i>
1 x 3/4 <i>25 x 20</i>	500 <i>3450</i>	1.69 <i>42.92</i>	0.53 <i>0.24</i>

▲ - Working Pressure Ratings are for reference only and based on Sch. 40 pipe. For the latest UL/ULC, and FM pressure ratings versus pipe schedule, please visit anvilintl.com or contact your local Anvil Representative.

MATERIAL SPECIFICATIONS

Dimensions: ASME B16.3

Material: ASTM A536 Grade 65-45-12

Finish: Black

Threads: NPT per ASME B1.20.1

Agency Approvals: All ductile iron threaded fittings are UL/ULC Listed and FM Approved.

NOTICE: Ductile iron fittings have higher tensile strength than that of steel pipe. Therefore, over tightening can cause damage to pipe threads which may cause leakage. Ductile iron fittings should be tightened approximately three turns beyond hand tight, but no more than four turns.

PROJECT INFORMATION		APPROVAL STAMP	
Project:		<input type="checkbox"/> Approved	
Address:		<input type="checkbox"/> Approved as noted	
Contractor:		<input type="checkbox"/> Not approved	
Engineer:		Remarks:	
Submittal Date:			
Notes 1:			
Notes 2:			

FIG. 3201

90° Elbow

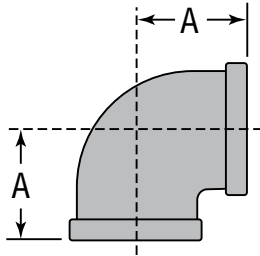

For Listings/Approval Details and Limitations, visit our website at www.anvilintl.com or contact an Anvil® Sales Representative.

FIGURE 3201 - 90° ELBOW

Nominal Size	Maximum Working Pressure▲	Dimension A	Approx. Wt. Each
<i>In. (mm)</i>	<i>PSI (kPa)</i>	<i>In. (mm)</i>	<i>Lbs. (kg)</i>
1 20	500 3450	1.50 38.10	0.62 0.28
1¼ 32	500 3450	1.75 44.45	0.90 0.41
1½ 40	500 3450	1.94 49.276	1.20 0.54
2 50	500 3450	2.25 57.15	1.85 0.84

▲ – Working Pressure Ratings are for reference only and based on Sch. 40 pipe. For the latest UL/ULC, and FM pressure ratings versus pipe schedule, please visit anvilintl.com or contact your local Anvil Representative.

MATERIAL SPECIFICATIONS

Dimensions: ASME B16.3

Material: ASTM A536 Grade 65-45-12

Finish: Black

Threads: NPT per ASME B1.20.1

Agency Approvals: All ductile iron threaded fittings are UL/ULC Listed and FM Approved.

NOTICE: Ductile iron fittings have higher tensile strength than that of steel pipe. Therefore, over tightening can cause damage to pipe threads which may cause leakage. Ductile iron fittings should be tightened approximately three turns beyond hand tight, but no more than four turns.

PROJECT INFORMATION

APPROVAL STAMP

Project:	<input type="checkbox"/> Approved
Address:	<input type="checkbox"/> Approved as noted
Contractor:	<input type="checkbox"/> Not approved
Engineer:	Remarks:
Submittal Date:	
Notes 1:	
Notes 2:	



HANGER MATERIAL

Threaded Rods

Low Carbon Steel Threaded Rod

The most economical and most common form of Threaded Rod. Typically used by the plumbing and contracting trades. Used in maintenance departments in various applications including hanging, mounting, bracing, supporting, and fastening applications.

- Low carbon steel according to ASTM A307, Grade A requirements
- Conforms to ASME B18.31.3
- Class 1A rolled threads
- Zinc Plated according to Fe/Zn 3AT Per ASTM F1941
- Hot Dip Galvanized according to ASTM A153 or F2329
- 60,000 psi Min. Tensile Strength



		1 ft				2 ft				3 ft				6 ft				10 ft				12 ft					
		Plain		Zinc		Plain		Zinc		Plain		Zinc		Hot Dip Galvanized		Plain		Zinc		Hot Dip Galvanized		Plain		Zinc		Hot Dip Galvanized	
Diameter	Thread Size	Part No.	Part No.	Part No.	Part No.	Part No.	Part No.	Part No.	Part No.	Part No.	Part No.	Part No.	Part No.	Part No.	Part No.	Part No.	Part No.	Part No.	Part No.	Part No.	Part No.	Part No.	Part No.	Part No.	Part No.	Part No.	Part No.
#6	32	-	-	-	-	47002	47052	-	-	47102	47152	-	-	-	-	-	-	-	-	-	-	-	-	-	-	-	-
#8	32	-	-	-	-	47003	47053	-	-	47103	47153	-	-	47136	47186	-	-	-	-	-	-	-	-	-	-	-	-
#10	24	-	-	-	-	47004	47054	-	-	47104	47154	-	-	47137	47187	-	-	-	-	-	-	-	-	-	-	-	-
#12	24	-	-	-	-	47006	47056	-	-	-	47156	-	-	-	-	-	-	-	-	-	-	-	-	-	-	-	-
1/4"	20	0156376	0156317	0156377	0156318	47007	47057	-	-	47107	47157	-	-	47140	47190	-	-	47207	47257	-	-	-	-	-	-	-	-
5/16"	18	0156378	0156319	0156379	0156320	47009	47059	-	-	47109	47159	-	-	47141	47191	-	-	47209	47259	-	-	-	-	-	-	-	-
3/8"	16	0156380	0156321	0156381	0156322	47011	47061	47602	47111	47161	47618	47142	47192	47634	47211	47261	47650	-	-	-	-	-	-	-	-	-	-
7/16"	14	0156382	0156323	0156383	0156324	47013	47063	0156404	47113	47163	-	47143	47193	-	47213	47263	-	-	-	-	-	-	-	-	-	-	-
1/2"	13	0156384	0156325	0156385	0156326	47015	47065	47604	47115	47165	47620	47144	47194	47636	47215	47265	47652	-	-	-	-	-	-	-	-	-	-
9/16"	12	0156386	0156327	0156387	0156328	47017	47067	-	47117	47167	-	47145	47195	-	47217	47267	-	-	-	-	-	-	-	-	-	-	-
5/8"	11	0156388	0156329	0156389	0156330	47019	47069	47606	47119	47169	47622	47146	47196	47638	47219	47269	47654	-	-	-	-	-	-	-	-	-	-
3/4"	10	0156390	0156331	0156391	0156332	47021	47071	47607	47121	47171	47623	47147	47197	47639	47221	47271	47655	-	-	-	-	-	-	-	-	-	-
7/8"	9	0156392	0156333	0156393	0156334	47023	47073	0156408	47123	47173	47624	47148	47198	47640	47223	47273	47656	-	-	-	-	-	-	-	-	-	-
1"	8	0156394	0156335	0156395	0156336	47025	47075	47609	47125	47175	47625	47149	47199	47641	47225	47275	47657	-	-	-	-	-	-	-	-	-	-
1-1/8"	7	-	-	-	-	47027	47077	-	47127	47177	47626	47150	47200	47642	47227	47277	47658	-	-	-	-	-	-	-	-	-	-
1-1/4"	7	-	-	-	-	47028	47078	47611	47128	47178	47627	47151	47201	47643	47228	47278	47659	-	-	-	-	-	-	-	-	-	-
1-3/8"	6	-	-	-	-	47029	47079	-	47129	47179	-	47233	47237	47644	47229	47279	47660	-	-	-	-	-	-	-	-	-	-
1-1/2"	6	-	-	-	-	47030	47080	-	47130	47180	47629	47234	47238	47645	47230	47280	47661	-	-	-	-	-	-	-	-	-	-
1-3/4"	5	-	-	-	-	47031	47081	-	47131	47181	47630	47235	47239	47646	47231	47281	47662	-	-	-	-	-	-	-	-	-	-
2"	4.5	-	-	-	-	47032	47082	-	47132	47182	-	47236	47240	47647	47232	47282	47663	-	-	-	-	-	-	-	-	-	-

		3 ft		6 ft		12 ft	
		Plain	Zinc	Plain	Zinc	Plain	Zinc
Diameter	Thread Size	Part No.	Part No.	Part No.	Part No.	Part No.	Part No.
#10	32	47005	47055	47105	47155	-	-
1/4"	28	47008	47058	47108	47158	47208	47258
5/16"	24	47010	47060	47110	47160	47210	47260
3/8"	24	47012	47062	47112	47162	47212	47262
7/16"	20	47014	47064	47114	47164	47214	47264
1/2"	20	47016	47066	47116	47166	47216	47266
9/16"	18	47018	47068	47118	47168	-	47268
5/8"	18	47020	47070	47120	47170	47220	47270
3/4"	16	47022	47072	47122	47172	47222	47272
7/8"	14	47024	47074	47124	47174	47224	47274
1"	14	47026	47076	47126	47176	47226	47276
1-1/8"	12	47033	47083	47133	47183	47094	-
1-1/4"	12	47034	47084	47134	47184	47095	47098
1-1/2"	12	47035	47087	47135	47185	47096	-

Left Hand Low Carbon Steel Threaded Rod



The most economical and most common form of Threaded Rod. Typically used by the plumbing and contracting trades. Used in maintenance departments in various applications; left hand threading. Plain Finish, or bare metal finish which may contain a light coating of oil.

- 6 foot lengths

Thread - Left Hand - Coarse		
Diameter	Thread Size	Plain Part No.
1/4"	20	47302
5/16"	18	47303
3/8"	16	47304
1/2"	13	47306
5/8"	11	47308
3/4"	10	47309
7/8"	9	47310
1"	8	47311
1-1/8"	7	47312
1-1/4"	7	47313
1-1/2"	6	47315
2"	4.5	47318

Metric Threaded Rod

- Made from heat treated Class 8.8 steel.



		Class 4.6		Class 8.8	
		Plain	Zinc	Plain	Zinc
Diameter	Thread Size	Part No.	Part No.	Part No.	Part No.
M2	0.4	-	0162065	-	-
M3	0.5	-	0162068	-	-
M4	0.7	47556	0162070	-	-
M5	0.8	47570	0162071	-	-
M6	1.0	47571	0162072	47870	-
M8	1.25	47572	0162073	47872	-
M10	1.5	47573	0162075	47873	-
M12	1.75	47574	0162078	47874	-
M14	2.0	47575	0162081	47875	-
M16	2.0	47576	0162083	47876	-
M18	2.5	47577	0162085	47877	-
M20	2.5	47578	0162086	47878	-
M22	2.5	47579	-	47879	-
M24	3.0	47580	0162088	47880	-

		Class 4.6		Class 8.8	
		Plain	Zinc	Plain	Zinc
Diameter	Thread Size	Part No.	Part No.	Part No.	Part No.
M27	3.0	47581	0162089	47881	-
M30	3.5	47582	0162090	47882	-
M33	3.5	47733	-	47883	-
M36	4.0	47583	-	47884	-
M39	4.0	47734	-	47885	-
M42	4.5	47735	-	47886	-
M48	5.0	47737	-	-	-

Thread - Fine		
Diameter	Thread Size	Class 4.6 Zinc Part No.
M8	1.0	0162074
M10	1.0	0162077
M10	1.25	0162076
M12	1.25	0162080
M12	1.5	0162079
M14	1.5	0162082
M16	1.5	0162084

HOW DO YOU PREFER TO BUY?

Local Store | Personal Service | Inventory Solutions | fastenal.com

105 Stainless Steel Loop Hanger



- Recommended for the suspension of stationary stainless steel pipe lines
- Conforms with Federal Specification WW-H-171 (Type 7), Manufacturers Standardization Society (MSS) SP-58 (Type 7)

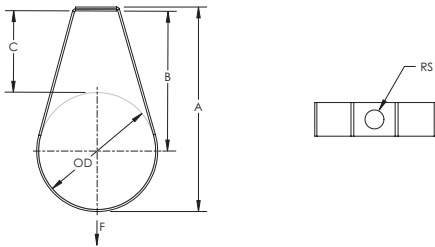

Material: Stainless Steel 304 (EN 1.4301)

Part Number	Pipe Size	Outer Diameter OD	Rod Size RS	A	B	C	Static Load F
1050050S4	1/2"	0.675"	3/8"	2 7/8"	2 5/16"	1 7/8"	600 lb
1050075S4	3/4"	1.050"	3/8"	3 1/8"	2 3/8"	1 7/8"	600 lb
1050100S4	1"	1.315"	3/8"	3 3/8"	2 9/16"	1 7/8"	600 lb
1050125S4	1 1/4"	1.660"	3/8"	3 3/4"	2 11/16"	1 7/8"	600 lb
1050150S4	1 1/2"	1.900"	3/8"	4 1/16"	2 15/16"	2"	600 lb
1050200S4	2"	2.375"	3/8"	4 7/16"	3 1/16"	1 7/8"	600 lb
1050250S4	2 1/2"	2.875"	1/2"	4 15/16"	3 5/16"	1 7/8"	970 lb
1050300S4	3"	3.500"	1/2"	5 9/16"	3 5/8"	1 7/8"	970 lb
1050350S4	3 1/2"	4.000"	1/2"	6 1/16"	3 7/8"	1 7/8"	970 lb
1050400S4	4"	4.500"	5/8"	6 9/16"	4 1/8"	1 7/8"	1,250 lb
1050500S4	5"	5.563"	5/8"	7 5/8"	4 11/16"	1 7/8"	1,250 lb
1050600S4	6"	6.625"	3/4"	8 3/4"	5 1/16"	1 3/4"	1,600 lb
1050800S4	8"	8.625"	3/4"	10 3/4"	6 1/16"	1 3/4"	1,800 lb

WARNING

nVent products shall be installed and used only as indicated in nVent's product instruction sheets and training materials. Instruction sheets are available at www.erico.com and from your nVent customer service representative. Improper installation, misuse, misapplication or other failure to completely follow nVent's instructions and warnings may cause product malfunction, property damage, serious bodily injury and death and/or void your warranty.

© 2021 nVent All rights reserved

nVent, nVent CADDY, nVent ERICO, nVent ERIFLEX and nVent LENTON are owned by nVent or its global affiliates.

All other trademarks are the property of their respective owners. nVent reserves the right to change specifications without prior notice.



300 Universal Beam Clamp



- Conforms with Federal Specification WW-H-171 (Type 23), Manufacturers Standardization Society ANSI®/MSS-SP-58 (Type 19 and 23)

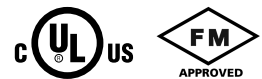
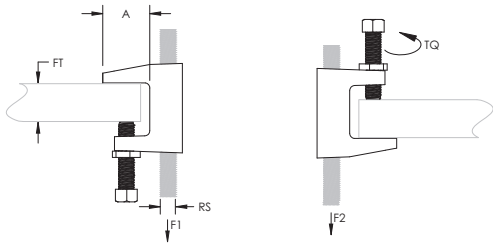

Material: Steel

Part Number	Rod Size RS	Flange Thickness FT	A	Torque TQ	Static Load 1 F1	Static Load 2 F2	Certifications	Standard Packaging Quantity
Finish: Plain								
3000037PL	3/8"	13/16" Max	1 1/8"	5 ft lb	500 lb	250 lb	cULus, FM	100 pc
3000050PL	1/2"	13/16" Max	1 1/8"	8 ft lb	950 lb	760 lb	cULus, FM	50 pc
3000062PL	5/8"	13/16" Max	1 1/8"	5 ft lb	950 lb	760 lb	cULus	50 pc
3000075PL	3/4"	13/16" Max	1 1/8"	5 ft lb	950 lb	760 lb	cULus	50 pc
3000087PL	7/8"	13/16" Max	1 1/8"	5 ft lb	950 lb	760 lb	cULus	50 pc
Finish: Electrogalvanized								
3000037EG	3/8"	13/16" Max	1 1/8"	5 ft lb	500 lb	250 lb	cULus, FM	100 pc
3000050EG	1/2"	13/16" Max	1 1/8"	8 ft lb	950 lb	760 lb	cULus, FM	50 pc
3000062EG	5/8"	13/16" Max	1 1/8"	5 ft lb	950 lb	760 lb	cULus	50 pc
3000075EG	3/4"	13/16" Max	1 1/8"	5 ft lb	950 lb	760 lb	cULus	50 pc
3000087EG	7/8"	13/16" Max	1 1/8"	5 ft lb	950 lb	760 lb	cULus	50 pc

Setscrew must be tightened and torqued onto the sloped side of the I-beam.

Recognizing that torque wrenches are generally not used or available on many job sites, the setscrew should be tightened so it contacts the I-beam and then an additional 1/4 to 1/2 turn added.

ANSI is a registered trademark of American National Standards Institute. FM is a registered certification mark of FM Approvals LLC, LTD. UL, UR, cUL, cUR, cULus and cURus are registered certification marks of UL LLC.

WARNING

Pentair products shall be installed and used only as indicated in Pentair's product instruction sheets and training materials. Instruction sheets are available at erico.pentair.com and from your Pentair customer service representative. Improper installation, misuse, misapplication or other failure to completely follow Pentair's instructions and warnings may cause product malfunction, property damage, serious bodily injury and death and/or void your warranty.

© 2017 Pentair All rights reserved

Pentair, CADDY, CADWELD, CRITEC, ERICO, ERIFLEX, ERITECH and LENTON are owned by Pentair or its global affiliates.

All other trademarks are the property of their respective owners. Pentair reserves the right to change specifications without prior notice.



SAMMY X-PRESS® Installs into Metal Deck, Purlin, or Tubular Steel

SAMMY X-PRESS® - Vertical Application



Application

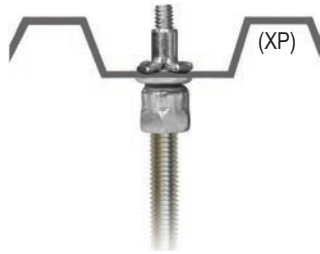

Product Features

- The **Sammy X-Press** expands to provide direct vertical attachment in:
 - light gauge steel deck or purlin (22 ga. - 1/8").
- Installs in seconds with Sammy X-Press It® Tool, saving time & installation costs.
- Use in applications where access to the back of the installed fastener is prohibited, i.e. metal roof deck, tubular steel, or vapor barrier fabric.
- Less jobsite material needed.
- No retaining nut required.
- Provides design flexibility.
- Manufactured in the U.S.A.



Approvals	Rod Size	Part Number	Model	Description	Ultimate Pullout (lbs)	UL Test Load (lbs)	UL Min Thick	FM Test Load (lbs)	FM Min Thick	Max Thick	Box Qty	Case Qty	Application
VERTICAL MOUNT													
	1/4"	8181922	XP 200	Sammy X-Press 200	1146 (22 ga)	185 (Luminaire) 250 (Luminaire)	.027" .056"			.125"	25	125	Metal Deck
 	3/8"	8150922	XP 20	Sammy X-Press 20	1146 (22 ga)	850 (2 1/2" Pipe) 185 (Luminaire) 250 (Luminaire) 283 (Conduit & Cable)	.027" .027" .056" .029"	940 (2" Pipe) 1475 (4" Pipe)	.029" .104"	.125"	25	125	Metal Deck
 	3/8"	8153922	XP 35	Sammy X-Press 35	1783 (16 ga)	1500 (4" Pipe) 185 (Luminaire) 250 (Luminaire) 416 (Conduit & Cable)	.060" .029" .056" .059"	940 (2" Pipe) 1475 (4" Pipe)	.029" .104"	.125"	25	125	Purlin
	3/8"	8150922	XP 20	Sammy X-Press 20	1146 (22 ga)	850 (2 1/2" Pipe)		Pre-Pour Structural Concrete @ 3000 psi			25	125	Metal Deck (Pre-Pour) Metal Deck (Post-Pour)

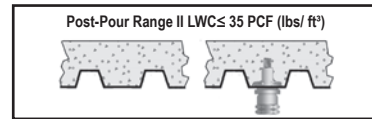
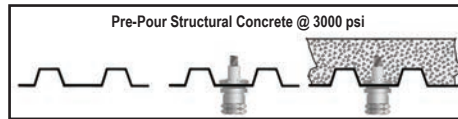
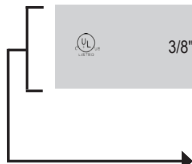

SAMMY X-PRESS SIDEWINDER™ - Horizontal Application



Application



Product Features

- The **Sammy X-Press Sidewinder** expands to provide horizontal attachment in:
 - 16 ga - 3/16" steel - purlin, tubular steel.
- Installs in seconds with Sammy X-Press It® Tool, saving time & installation costs.
- Use in applications where access to the back of the installed fastener is prohibited; i.e. metal roof deck, tubular steel, or vapor barrier fabric.
- Less jobsite material needed.
- No retaining nut required.
- Provides design flexibility.
- Manufactured in the U.S.A.



Approvals	Rod Size	Part Number	Model	Description	Ultimate Pullout (lbs)	UL Test Load (lbs)	UL Min Thick	FM Test Load (lbs)	Max Thick	Box Qty	Case Qty	Application
HORIZONTAL MOUNT												
	3/8"	8293957	SWXP 35	Sidewinder X-Press 35	1798 (16 ga)	1250 (3 1/2" Pipe) 80 (Luminaire) 416 (Conduit & Cable)	.059"		.125"	25	125	Purlin



SAMMY X-PRESS SWIVEL™ - Swivel Application



Application	Product Features
<p>FOR EXTREME OR VARIANT ROOF PITCHES</p>	<ul style="list-style-type: none"> The Sammy X-Press Swivel allows you to hang plumb in extreme roof pitches: <ul style="list-style-type: none"> - 89° in z-purlin - 45° in metal deck for 12/12 pitch Installs in seconds with Sammy X-Press It® Tool, saving time & installation costs. Use in applications where access to the back of the installed fastener is prohibited. ie. metal roof deck, tubular steel, or vapor barrier fabric. <ul style="list-style-type: none"> Less jobsite material needed. No retaining nut required. Provides design flexibility. Manufactured in the U.S.A.



Approvals	Rod Size	Part Number	Model	Description	Ultimate Pullout (lbs)	UL Test Load (lbs)	UL Min Thick	FM Test Load (lbs)	FM Min Thick	Max Thick	Box Qty	Case Qty	Application
SWIVEL MOUNT													
	3/8"	8294922	SXP 20	Swivel X-Press 20	1061 (22 ga Vert) 829 (45° Off Vert)	750 (2" Pipe) 170 Vertical (Luminaire) 80 @ 45° (Luminaire) 283 Vertical (Conduit & Cable) 233 @ 45° (Conduit & Cable)	.029"	635 (2" Pipe)	.029"	.125"	25	125	Metal Deck
	3/8"	8295922	SXP 35	Swivel X-Press 35	1675 (16 ga Vert) 1558 (89° Off Vert)	1250 (3-1/2" Pipe) 250 Vertical (Luminaire) 80 @ 90° (Luminaire) 500 Vertical (Conduit & Cable) 333 @ 89° (Conduit & Cable)	.059"	635 (2" Pipe)	.029"	.125"	25	125	Purlin
	1/2"	8272957	SXP 2.0	Swivel X-Press 2.0	1061 (22 ga Vert) 829 (45° Off Vert)		.027"	.125"			25	125	Metal Deck
	1/2"	8271957	SXP 3.5	Swivel X-Press 3.5	1675 (16 ga Vert) 1558 (89° Off Vert)		.060"	.125"			25	125	Purlin

SAMMY X-PRESS IT® Installation Tool



Application	Product Features
	<ul style="list-style-type: none"> The Sammy X-Press expands to provide direct vertical attachment in: <ul style="list-style-type: none"> - metal deck (22-16 gauge) - z-purlin (18-16 gauge) Manufactured in the U.S.A.



Part Number	Model	Description	Qty
8194910	UXPIT*	Universal X-Press It Tool	1
8152910	XPDB	25/64" Drill Bit	1

*Tool Includes: Sleeve, Bit Receiver, Hex Wrench, and 25/64" Drill Bit.



SPRINKLER HEADS

Victaulic® FireLock™ Series FL-QR

Standard Coverage, Quick Response

Upright, Pendent and Recessed Pendent Sprinklers

K2.8 (4.0), K4.2 (6.1), K5.6 (8.1), K8.0 (11.5)



41.01



1.0 PRODUCT DESCRIPTION

QUICK RESPONSE UPRIGHT SPRINKLERS				
SIN	V2815	V4215	V2704	V3402
ORIENTATION	UPRIGHT	UPRIGHT	UPRIGHT	UPRIGHT
K-FACTOR ¹	2.8 Imp./4.0 S.I.	4.2 Imp./6.1 S.I.	5.6 Imp./8.1 S.I.	8.0 Imp./11.5 S.I.
CONNECTION	½" NPT/15mm BSPT	½" NPT/15mm BSPT	½" NPT/15mm BSPT/IGS	¾" NPT/20mm BSPT/IGS
MAX. WORKING PRESSURE	175 psi/1200 kPa	175 psi/1200 kPa	175 psi/1200 kPa cULus 250 psi/1725 kPa	175 psi/1200 kPa
GLOBE RE-DESIGNATION	GL2815	GL4215	-	-
GLOBE EQUIVALENT	-	-	GL5615	GL8118

QUICK RESPONSE PENDENT SPRINKLERS				
SIN	V2801	V4201	V2708	V3406
ORIENTATION	PENDENT	PENDENT	PENDENT	PENDENT
K-FACTOR ¹	2.8 Imp./4.0 S.I.	4.2 Imp./6.1 S.I.	5.6 Imp./8.1 S.I.	8.0 Imp./11.5 S.I.
CONNECTION	½" NPT/15mm BSPT	½" NPT/15mm BSPT	½" NPT/15mm BSPT/IGS	¾" NPT/20mm BSPT/IGS
MAX. WORKING PRESSURE	175 psi/1200 kPa	175 psi/1200 kPa	175 psi/1200 kPa cULus 250 psi/1725 kPa	175 psi/1200 kPa
GLOBE RE-DESIGNATION	GL2801	GL4201	-	-
GLOBE EQUIVALENT	-	-	GL5601	GL8101

QUICK RESPONSE RECESSED PENDENT SPRINKLERS				
SIN	V2801	V4201	V2708	V3406
ORIENTATION	PENDENT	PENDENT	PENDENT	PENDENT
K-FACTOR ¹	2.8 Imp./4.0 S.I.	4.2 Imp./6.1 S.I.	5.6 Imp./8.1 S.I.	8.0 Imp./11.5 S.I.
CONNECTION	½" NPT/15mm BSPT	½" NPT/15mm BSPT	½" NPT/15mm BSPT/IGS	¾" NPT/20mm BSPT/IGS
MAX. WORKING PRESSURE	175 psi/1200 kPa	175 psi/1200 kPa	175 psi/1200 kPa cULus 250 psi/1725 kPa	175 psi/1200 kPa
ESCUTCHEON	Recessed	Recessed	Recessed	Recessed
GLOBE RE-DESIGNATION	GL2801	GL4201	-	-
GLOBE EQUIVALENT	-	-	GL5601	GL8101

AVAILABLE GUARDS/SHIELDS				
SPRINKLER	V28	V42	V27	V34
Upright			■	■
Pendent			■	■

AVAILABLE WRENCHES							
SPRINKLER	V56-2 Recessed	V56 Open End	V27-2 Recessed	V27 Open End	V34-2 Recessed	V34 Open End	⅜ Hex-Bit
V2815 and V4215		■					
V2707 and V2704				■			■
V3402						■	■
V2801, and V4201	■	■					
V2706 and V2708			■	■			■
V3406					■	■	■

Factory Hydrostatic Test: 100% @ 500 psi/3447 kPa/34 bar

Min. Operating Pressure: UL/FM: 7 psi/48 kPa/.5 bar
VdS: 5 psi/35 kPa/.35 bar (Upright only)

Temperature Rating: See tables in section 2.0

¹ For K-Factor when pressure is measured in bar, multiply S.I. units by 10.0.

ALWAYS REFER TO ANY NOTIFICATIONS AT THE END OF THIS DOCUMENT REGARDING PRODUCT INSTALLATION, MAINTENANCE OR SUPPORT.



2.0 CERTIFICATION/LISTINGS



UPRIGHT APPROVALS/LISTINGS				
SIN	V2815	V4215	V2704	V3402
Nominal K Factor Imperial	2.8	4.2	5.6	8.0
Nominal K Factor S.I. ²	4.0	6.1	8.1	11.5
Orientation	UPRIGHT	UPRIGHT	UPRIGHT	UPRIGHT
Approved Temperature Ratings F°/C°				
cULus	135°F/57°C 155°F/68°C 175°F/79°C 200°F/93°C 286°F/141°C	135°F/57°C 155°F/68°C 175°F/79°C 200°F/93°C 286°F/141°C	135°F/57°C 155°F/68°C 175°F/79°C 200°F/93°C 286°F/141°C	135°F/57°C 155°F/68°C 175°F/79°C 200°F/93°C 286°F/141°C
FM	-	-	135°F/57°C 155°F/68°C 175°F/79°C 200°F/93°C 286°F/141°C	135°F/57°C 155°F/68°C 175°F/79°C 200°F/93°C 286°F/141°C
LPCB	-	-	135°F/57°C 155°F/68°C 175°F/79°C 200°F/93°C 286°F/141°C	135°F/57°C 155°F/68°C 175°F/79°C 200°F/93°C 286°F/141°C
CE, UKCA	-	-	135°F/57°C 155°F/68°C 175°F/79°C 200°F/93°C 286°F/141°C	135°F/57°C 155°F/68°C 175°F/79°C 200°F/93°C 286°F/141°C
VdS	-	-	135°F/57°C 155°F/68°C 175°F/79°C 200°F/93°C 286°F/141°C	135°F/57°C 155°F/68°C 175°F/79°C 200°F/93°C 286°F/141°C
CCC K-ZSTZ	-	-	155°F/68°C 175°F/79°C 286°F/141°C	155°F/68°C 175°F/79°C 286°F/141°C

² For K-Factor when pressure is measured in Bar, multiply S.I. units by 10.

PENDENT APPROVALS/LISTINGS				
SIN	V2801	V4201	V2708	V3406
Nominal K Factor Imperial	2.8	4.2	5.6	8.0
Nominal K Factor S.I. ²	4.0	6.1	8.1	11.5
Orientation	PENDENT	PENDENT	PENDENT	PENDENT
Escutcheon	Flush/Extended	Flush/Extended	Flush/Extended	Flush/Extended
Approved Temperature Ratings F°/C°				
cULus	135°F/57°C 155°F/68°C 175°F/79°C 200°F/93°C 286°F/141°C	135°F/57°C 155°F/68°C 175°F/79°C 200°F/93°C 286°F/141°C	135°F/57°C 155°F/68°C 175°F/79°C 200°F/93°C 286°F/141°C	135°F/57°C 155°F/68°C 175°F/79°C 200°F/93°C 286°F/141°C
FM	-	-	135°F/57°C 155°F/68°C 175°F/79°C 200°F/93°C 286°F/141°C	135°F/57°C 155°F/68°C 175°F/79°C 200°F/93°C 286°F/141°C
CCC K-ZSTX	-	-	155°F/68°C 200°F/93°C 286°F/141°C	155°F/68°C 200°F/93°C 286°F/141°C

² For K-Factor when pressure is measured in Bar, multiply S.I. units by 10.

NOTES

- Listings and approval as of printing.
- Where cULus Listed, Polyester and VC-250 Coatings Listed as Corrosion Resistant (V3402 with VC-250 Only)
- Where FM Approved, VC-250 Coating Approved as Corrosion Resistant
- New York City Acceptance - All UL Listed and/or FM Approved sprinklers acceptable to NYC per section 28-113 of the Administrative Code and the OTCR Rule.

2.0 CERTIFICATION/LISTINGS (CONTINUED)

RECESSED PENDENT APPROVALS/LISTINGS				
SIN	V2801	V4201	V2708	V3406
Nominal K Factor Imperial	2.8	4.2	5.6	8.0
Nominal K Factor S.I. ²	4.0	6.1	8.1	11.5
Orientation	PENDENT	PENDENT	PENDENT	PENDENT
Escutcheon	Recessed	Recessed	Recessed	Recessed
Approved Temperature Ratings F°/C°				
cULus	135°F/57°C 155°F/68°C 175°F/79°C 200°F/93°C 286°F/141°C	135°F/57°C 155°F/68°C 175°F/79°C 200°F/93°C 286°F/141°C	135°F/57°C 155°F/68°C 175°F/79°C 200°F/93°C	135°F/57°C 155°F/68°C 175°F/79°C 200°F/93°C 286°F/141°C
FM WITH ½" ADJUSTMENT ESCUTCHEON ONLY	-	-	135°F/57°C 155°F/68°C 175°F/79°C 200°F/93°C	135°F/57°C 155°F/68°C 175°F/79°C 200°F/93°C
CCC K-ZSTX	-	-	155°F/68°C 200°F/93°C 286°F/141°C	155°F/68°C 286°F/141°C

² For K-Factor when pressure is measured in Bar, multiply S.I. units by 10.

NOTES

- Listings and approval as of printing.
- Where cULus Listed, Polyester and VC-250 Coatings Listed as Corrosion Resistant (V3402 with VC-250 Only)
- Where FM Approved, VC-250 Coating Approved as Corrosion Resistant
- New York City Acceptance - All UL Listed and/or FM Approved sprinklers acceptable to NYC per section 28-113 of the Administrative Code and the OTCR Rule.

3.0 SPECIFICATIONS – MATERIAL

Deflector: Bronze

Bulb Nominal Diameter: 3.0mm

Load Screw: Bronze

Pip Cap: Bronze

Spring Seal: PTFE coated Beryllium nickel alloy

Frame: Brass

Lodgement Spring: Stainless steel

Installation Wrench: Ductile iron

Sprinkler Frame Finishes:

- Plain brass
- Chrome plated
- White polyester painted^{3, 4}
- Flat black polyester painted^{3, 4}
- Custom polyester painted^{3, 4}
- VC-250⁵

³ Not available on the Intermediate Level Style Pendant.

⁴ UL Listed for corrosion resistance.

⁵ UL Listed and FM Approved for corrosion resistance.

NOTE

- For cabinets and other accessories refer to separate sheet.

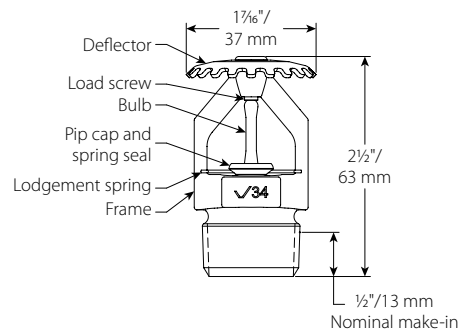
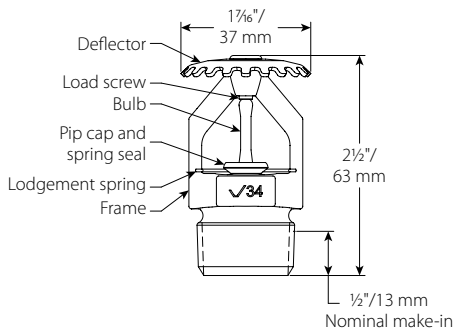
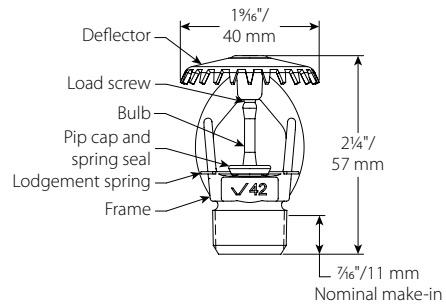
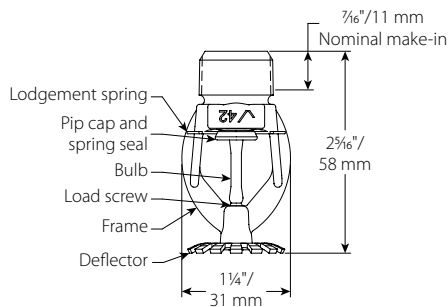
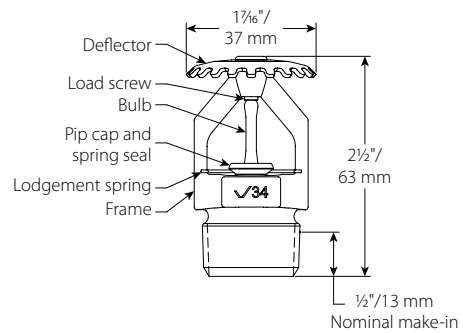
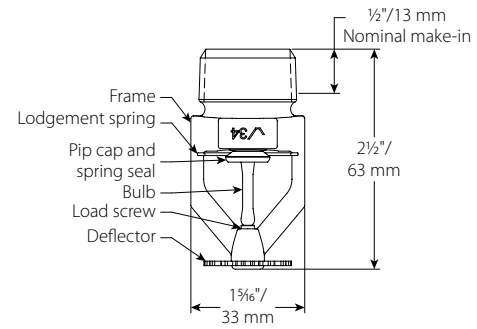

4.0 DIMENSIONS

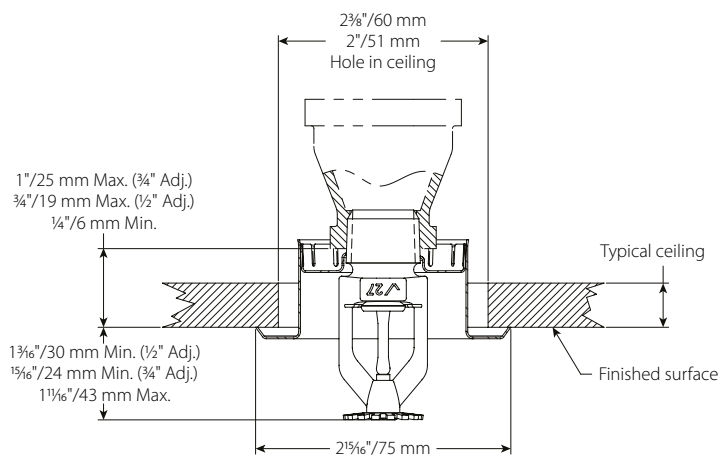
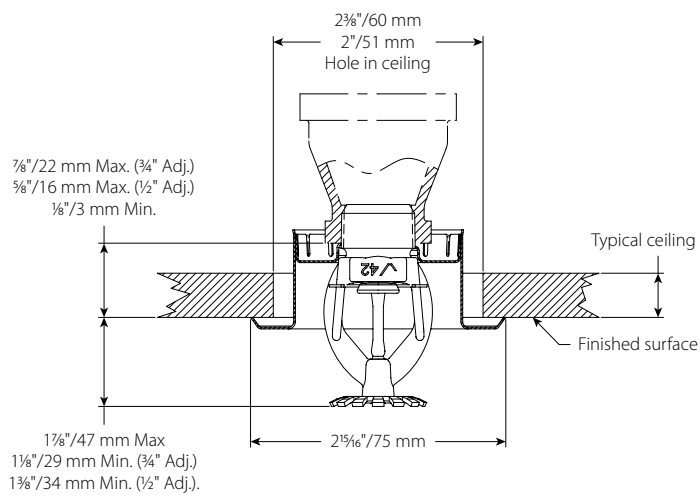
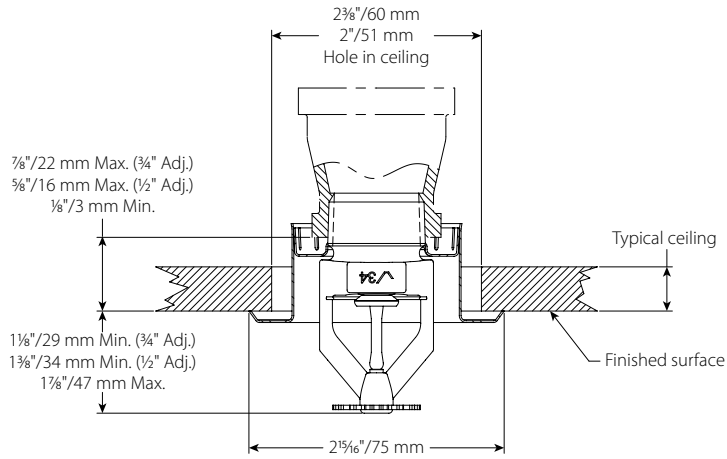

5.0 PERFORMANCE

Sprinkler is to be installed and designed as per NFPA, FM Datasheets, or any local standards.

6.0 NOTIFICATIONS

⚠ WARNING	
	<ul style="list-style-type: none"> • Read and understand all instructions before attempting to install any Victaulic products. • Always verify that the piping system has been completely depressurized and drained immediately prior to installation, removal, adjustment, or maintenance of any Victaulic products. • Wear safety glasses, hardhat, and foot protection. <p>Failure to follow these instructions could result in death or serious personal injury and property damage.</p>
<ul style="list-style-type: none"> • These products shall be used only in fire protection systems that are designed and installed in accordance with current, applicable National Fire Protection Association (NFPA 13, 13D, 13R, etc.) standards, or equivalent standards, and in accordance with applicable building and fire codes. These standards and codes contain important information regarding protection of systems from freezing temperatures, corrosion, mechanical damage, etc. • The installer shall understand the use of this product and why it was specified for the particular application. • The installer shall understand common industry safety standards and potential consequences of improper product installation. • It is the system designer's responsibility to verify suitability of materials for use with the intended fluid media within the piping system and external environment. • The material specifier shall evaluate the effect of chemical composition, pH level, operating temperature, chloride level, oxygen level, and flow rate on materials to confirm system life will be acceptable for the intended service. <p>Failure to follow installation requirements and local and national codes and standards could compromise system integrity or cause system failure, resulting in death or serious personal injury and property damage.</p>	

7.0 REFERENCE MATERIALS

Ratings: All glass bulbs are rated for temperatures from -67°F/-55°C to those shown in the table below.

[I-40: Victaulic FireLock™ Automatic Sprinklers Installation and Maintenance Instructions](#)

[I-V9: Style V9 Victaulic FireLock™ IGS™ Installation-Ready™ Sprinkler Coupling Installation Instructions](#)

User Responsibility for Product Selection and Suitability

Each user bears final responsibility for making a determination as to the suitability of Victaulic products for a particular end-use application, in accordance with industry standards and project specifications, as well as Victaulic performance, maintenance, safety, and warning instructions. Nothing in this or any other document, nor any verbal recommendation, advice, or opinion from any Victaulic employee, shall be deemed to alter, vary, supersede, or waive any provision of Victaulic Company's standard conditions of sale, installation guide, or this disclaimer.

Intellectual Property Rights

No statement contained herein concerning a possible or suggested use of any material, product, service, or design is intended, or should be construed, to grant any license under any patent or other intellectual property right of Victaulic or any of its subsidiaries or affiliates covering such use or design, or as a recommendation for the use of such material, product, service, or design in the infringement of any patent or other intellectual property right. The terms "Patented" or "Patent Pending" refer to design or utility patents or patent applications for articles and/or methods of use in the United States and/or other countries.

Note

This product shall be manufactured by Victaulic or to Victaulic specifications. All products to be installed in accordance with current Victaulic installation/assembly instructions. Victaulic reserves the right to change product specifications, designs and standard equipment without notice and without incurring obligations.

Installation

Reference should always be made to the Victaulic installation handbook or installation instructions of the product you are installing. Handbooks are included with each shipment of Victaulic products, providing complete installation and assembly data, and are available in PDF format on our website at www.victaulic.com.

Warranty

Refer to the Warranty section of the current Price List or contact Victaulic for details.

Trademarks

Victaulic and all other Victaulic marks are the trademarks or registered trademarks of Victaulic Company, and/or its affiliated entities, in the U.S. and/or other countries.



HYDRAULICS

Hydrant Flow Test Report

Test Date 2/6/2024

Test Time 1:45pm

Location

46 Shriji Lane
Erwin, NC

Tested by

J&D Sprinkler Company

Notes

Test was performed by Farrin Dunn and Travis Curry with J&D Sprinkler Company.

Read Hydrant

52 psi **static pressure**
36 psi **residual pressure**
hydrant elevation

Flow Hydrant(s)

Outlet	Elev	Size	C	Pitot Pressure	Flow
#1		2.5	.9		840 gpm

Flow Graph

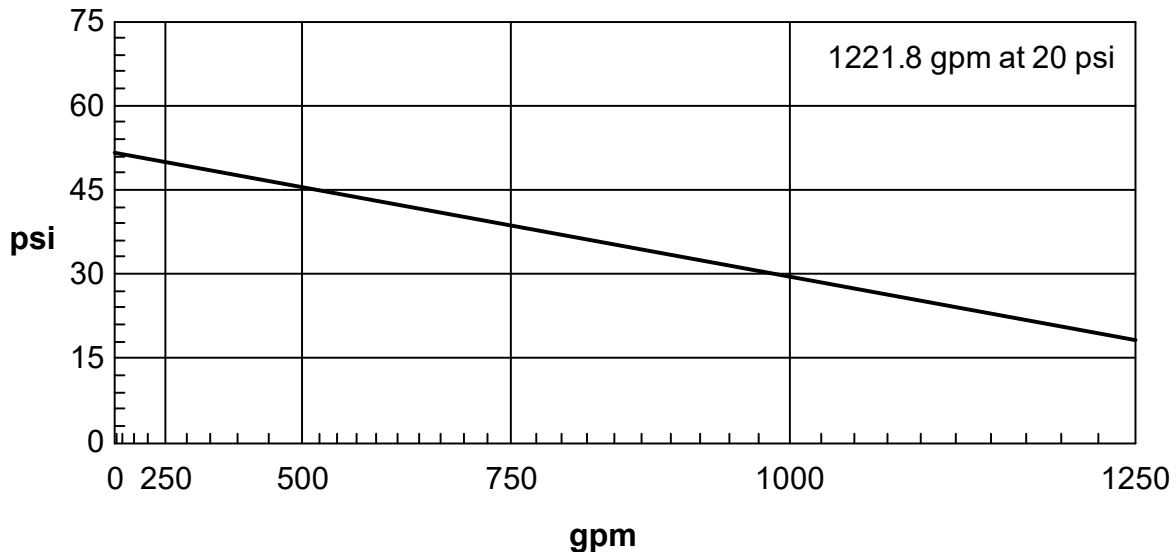

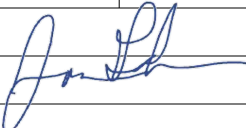

Job	
Job Number F24084	Designer MWL
Job Name: HARBOR FREIGHT TOOLS	Phone 919-553-2356
Address 1 46 SHRIJI LN	State Certification/License Number 16269FS
Address 2 ERWIN, NC	AHJ 
Address 3	Job Site/Building

System	
Density 0.20gpm/ft ²	Area of Application 1500ft ² (Actual 1502ft ²)
Most Demanding Sprinkler Data 5.6 K-Factor 25.00 at 19.930	Hose Streams 250.00
Coverage Per Sprinkler 125ft ²	Number Of Sprinklers Calculated 13
	Number Of Nozzles Calculated 0
System Pressure Demand 41.685	System Flow Demand 329.07
Total Demand 579.07 @ 41.685	Pressure Result +2.275 (5.2%)

Supplies						Check Point Gauges			
Node	Name	Flow(gpm)	Hose Flow(gpm)	Static(psi)	Residual(psi)	Identifier	Pressure(psi)	K-Factor(K)	Flow(gpm)
12	Water Supply	840.00	250.00	52.000	36.000	BOR (11)	30.834	59.26	329.07

Harbor Freight Shell FP REVISED BACKFLOW PLACEMENT Water Supply at Node 12 (840.00, 0.00, 52.000, 36.000)

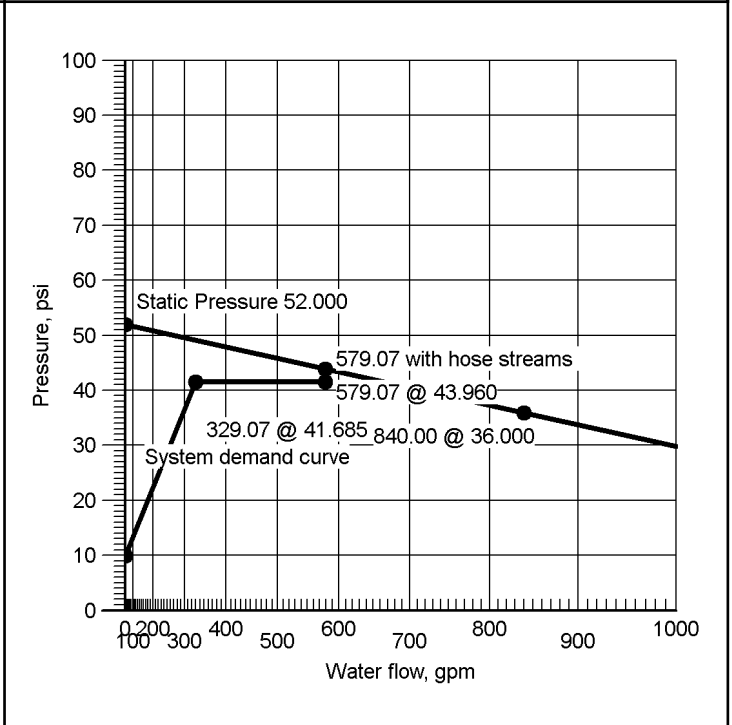
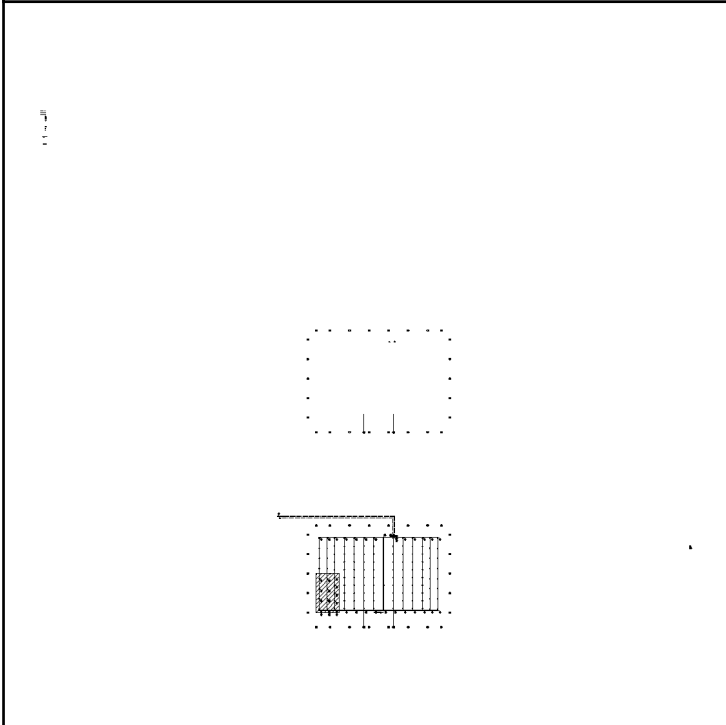

Hydraulic Calculations

for

Project Name: HARBOR FREIGHT TOOLS: (F24084)

Location: 46 SHRIJI LN, ERWIN, NC,

Drawing Name: Harbor Freight Shell FP REVISED BACKFLOW PLACEMENT

Calculation Date: 10/2/2024

Design

Remote Area Number: 1

Occupancy Classification: Ordinary Group II

Density 0.20gpm/ft²

Area of Application: 1500ft² (Actual 1502ft²)

Coverage per Sprinkler: 125ft²

Type of sprinklers calculated: Upright

No. of sprinklers calculated: 13

No. of nozzles calculated: 0

In-rack Demand: N/A gpm at Node: N/A

Hose Streams: 250.00 at Node: 12 Type: Allowance at Source

Total Water Required (including Hose Streams where applicable):

From Water Supply at Node 12: 579.07 @ 41.685 (Safety Margin = 2.275)

Type of System:

Volume of Dry/PreAction/Antifreeze/OtherAgent System: N/A

for Node: 12

Date: 2/6/2024

Location: 46 SHRIJI LN

Source: J&D SPRINKLER CO

Name of Contractor:

Address:

Phone Number:

Name of designer: MWL

Authority Having Jurisdiction: :

Notes:

Automatic peaking results

Left: 41.685

Right: 41.685

Hydraulic Graph

Job Name: HARBOR FREIGHT TOOLS
Remote Area Number: 1

N 1.85

Date: 10/2/2024

**Water Supply
Summary Sheet
Node: 12**

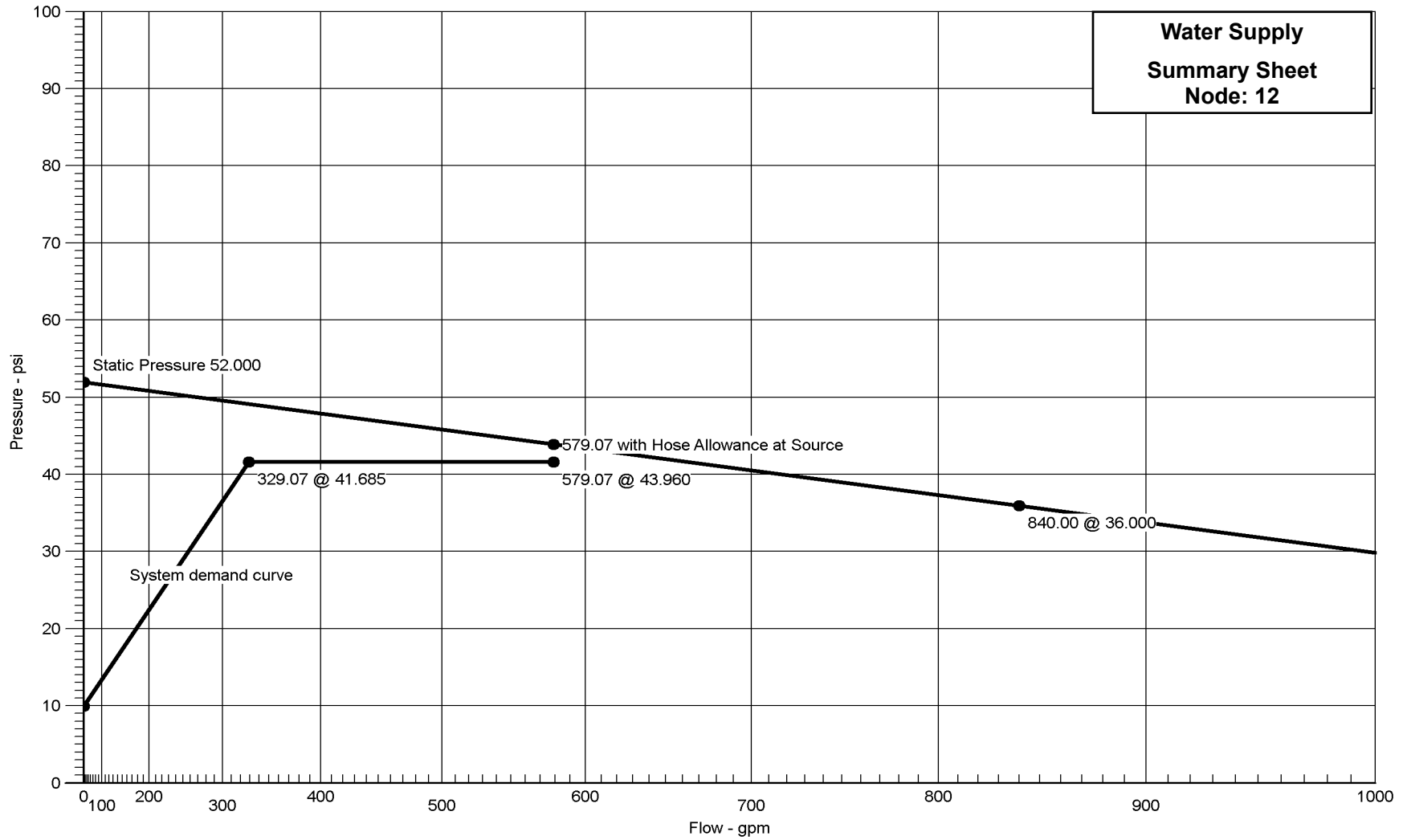

Supply:Static:52.000
Residual:36.000
Flowing:840.00
Available Flow @ 20 PSI:1221.34



Summary Of Outflowing Devices

Device	Actual Flow (gpm)	Minimum Flow (gpm)	K-Factor (K)	Pressure (psi)			
⇒ Sprinkler 101	25.00	25.00	5.6	19.930			
Sprinkler 102	25.01	25.00	5.6	19.946			
Sprinkler 103	25.12	25.00	5.6	20.117			
Sprinkler 104	25.19	25.00	5.6	20.231			
Sprinkler 105	25.19	25.00	5.6	20.240			
Sprinkler 106	25.26	25.00	5.6	20.347			
Sprinkler 107	25.44	25.00	5.6	20.637			
Sprinkler 108	25.29	25.00	5.6	20.392			
Sprinkler 109	25.29	25.00	5.6	20.400			
Sprinkler 110	25.47	25.00	5.6	20.678			
Sprinkler 111	25.67	25.00	5.6	21.012			
Sprinkler 112	25.47	25.00	5.6	20.687			

⇒ Most Demanding Sprinkler Data

Supply Analysis							
Node	Name	Static (psi)	Residual (psi)	@ Flow (gpm)	Available (psi)	@ Total Demand (gpm)	Required Pressure (psi)
12	Water Supply	52.000	36.000	840.00	43.960	579.07	41.685

Node Analysis					
Node Number	Elevation (Foot)	Node Type	Pressure at Node (psi)	Discharge at Node (gpm)	Notes
12	-3'-0	Supply	41.685	329.07	
101	20'-0½	Sprinkler	19.930	25.00	
102	19'-6	Sprinkler	19.946	25.01	
103	18'-11½	Sprinkler	20.117	25.12	
104	20'-1	Sprinkler	20.231	25.19	
105	20'-1	Sprinkler	20.240	25.19	
106	18'-5½	Sprinkler	20.347	25.26	
107	17'-11	Sprinkler	20.637	25.44	
108	19'-4½	Sprinkler	20.392	25.29	
109	19'-4½	Sprinkler	20.400	25.29	
110	18'-8	Sprinkler	20.678	25.47	
111	18'-0	Sprinkler	21.012	25.67	
112	18'-8	Sprinkler	20.687	25.47	
113	18'-0	Sprinkler	21.020	25.67	
1	18'-6½		21.581		
2	18'-6½		21.700		
3	13'-5		24.203		
4	13'-5		24.276		

Node Number	Elevation (Foot)	Node Type	Pressure at Node (psi)	Discharge at Node (gpm)	Notes
5	13'-5		24.362		
6	13'-5		24.461		
7	13'-5		24.577		
8	13'-5		24.710		
9	13'-5		25.058		
10	13'-5		25.434		
11	1'-6	Gauge	30.834		
13	18'-6½		21.534		
14	18'-6½		21.544		
15	13'-5		24.143		
16	13'-5		24.118		
17	13'-5		24.124		
18	13'-5		24.903		
19	13'-5		24.904		
20	13'-5		24.909		
21	13'-5		24.923		
22	13'-5		24.947		
23	18'-6½		22.155		
24	18'-6½		22.160		
25	18'-6½		22.162		
26	18'-6½		22.117		
27	18'-6½		22.141		

Node Number	Elevation (Foot)	Node Type	Pressure at Node (psi)	Discharge at Node (gpm)	Notes
28	18'-6½		22.030		
29	18'-6½		22.080		
30	18'-6½		21.892		
31	18'-6½		21.967		
32	18'-6½		21.803		

Pipe Information

Node 1	Elev 1 (Foot)	K-Factor	Flow added this step (q)	Nominal ID	Fittings & Devices	Length (Foot)	C Factor	Total(Pt)	Notes Fitting/Device (Equivalent Length) Fixed Pressure Losses, when applicable, are added directly to (Pf) and shown as a negative value.
	Node 2		Elev 2 (Foot)	Total Flow (Q)		Actual ID	Fitting (Foot)	Pf Friction Loss Per Unit (psi)	
		Total (Foot)			Friction(Pf)				
101	20'-0½	5.6	50.17	2	(See Notes)	3'-7	120	19.930	••••• Route 1 ••••• Sprinkler,, Flow (q) from Route 2 E(6'-2), PO(12'-3½)
1	18'-6½		75.17	2.1570		18'-5½	0.045030	0.658	
						22'-0½		0.993	
1	18'-6½		119.34	4		12'-6	120	21.581	Flow (q) from Route 4
2	18'-6½		194.51	4.2600		12'-6	0.009505	0.119	
2	18'-6½			2	(See Notes)	97'-1	120	21.700	PO(12'-3½) 2E(6'-2), PO(12'-3½)
3	13'-5		14.68	2.1570		36'-11	0.002195	2.209	
						134'-0		0.294	
3	13'-5		134.56	4		12'-6	120	24.203	Flow (q) from Route 6
4	13'-5		149.25	4.2600		12'-6	0.005823	0.073	
4	13'-5		13.85	4		12'-6	120	24.276	Flow (q) from Route 28
5	13'-5		163.10	4.2600		12'-6	0.006862	0.086	
5	13'-5		13.77	4		12'-6	120	24.362	Flow (q) from Route 24
6	13'-5		176.87	4.2600		12'-6	0.007973	0.100	
6	13'-5		14.45	4		12'-6	120	24.461	Flow (q) from Route 27
7	13'-5		191.32	4.2600		12'-6	0.009219	0.115	
7	13'-5		15.83	4		12'-6	120	24.577	Flow (q) from Route 21
8	13'-5		207.15	4.2600		12'-6	0.010679	-0.000 0.133	
8	13'-5		17.83	4	(See Notes)	1'-8	120	24.710	Flow (q) from Route 22 T(26'-4)
9	13'-5		224.98	4.2600		26'-4	0.012442	0.348	
						28'-0			
9	13'-5		104.09	4	(See Notes)	1'-9½	120	25.058	Flow (q) from Route 14 E(13'-2)
10	13'-5		329.07	4.2600		13'-2	0.025143	0.376	
						14'-11½			
10	13'-5			6	(See Notes)	11'-2	120	25.434	f, sCV(40'-3), BV(12'-7), BOR
11	1'-6		329.07	6.3570		52'-9½	0.003579	5.171	
						63'-11½		0.229	

Pipe Information

Node 1	Elev 1 (Foot)	K-Factor	Flow added this step (q)	Nominal ID	Fittings & Devices	Length (Foot)	C Factor	Total(Pt)	Notes Fitting/Device (Equivalent Length) Fixed Pressure Losses, when applicable, are added directly to (Pf) and shown as a negative value.	
										Node 2
11	1'-6			6	(See Notes)	182'-8	140	30.834		
12	-3'-0		329.07	6.2800		132'-4½	0.002856	1.951		
			250.00			315'-0½		8.900	41.685	
12			579.07						Total(Pt) Route 1	
102	19'-6	5.6	25.01	2	(See Notes)	10'-0	120	19.946	***** Route 2 ***** Sprinkler	
101	20'-0½		50.17	2.1570			0.021313	-0.230		
						10'-0		0.213		19.930
									Total(Pt) Route 2	
103	18'-11½	5.6	25.12	2	(See Notes)	10'-0	120	20.117	***** Route 3 ***** Sprinkler	
102	19'-6		25.16	2.1570			0.005945	-0.230		
						10'-0		0.060		19.946
									Total(Pt) Route 3	
104	20'-1	5.6	34.44	2	(See Notes)	3'-1½	120	20.231	***** Route 4 ***** Sprinkler,, Flow (q) from Route 8 E(6'-2), PO(12'-3½)	
13	18'-6½		59.63	2.1570		18'-5½	0.029337	0.669		
						21'-7		0.634		21.534
13	18'-6½		219.21	4		10'-0	120	21.534	Flow (q) from Route 1	
14	18'-6½		59.63	4.2600			0.001067			
						10'-0		0.011	21.544	
14	18'-6½		59.71	4		9'-8	120	21.544	Flow (q) from Route 5	
1	18'-6½		119.34	4.2600			0.003850	0.000		
						9'-8		0.037	21.581	
									Total(Pt) Route 4	
105	20'-1	5.6	34.51	2	(See Notes)	3'-1½	120	20.240	***** Route 5 ***** Sprinkler,, Flow (q) from Route 9 E(6'-2), PO(12'-3½)	
14	18'-6½		59.71	2.1570		18'-5½	0.029406	0.669		
						21'-7		0.635		21.544
									Total(Pt) Route 5	
106	18'-5½	5.6	25.26	2	(See Notes)	10'-0	120	20.347	***** Route 6 ***** Sprinkler	
107	17'-11		25.22	2.1570			0.005969	0.230		
						10'-0		0.060		

Pipe Information									
Node 1	Elev 1 (Foot)	K-Factor	Flow added this step (q)	Nominal ID	Fittings & Devices	Length (Foot)	C Factor	Total(Pt)	Notes Fitting/Device (Equivalent Length) Fixed Pressure Losses, when applicable, are added directly to (Pf) and shown as a negative value.
Node 2	Elev 2 (Foot)		Total Flow (Q)	Actual ID	Equiv. Length (Foot)	Fitting (Foot)	Pf Friction Loss Per Unit (psi)	Elev(Pe)	
						Total (Foot)		Friction(Pf)	
107	17'-11	5.6	25.44	2	(See Notes)	53'-5	120	20.637	Sprinkler, E(6'-2), PO(12'-3½)
15	13'-5		50.66	2.1570		18'-5½	0.021696	1.947	
						71'-10½		1.559	
15	13'-5		83.91	4		12'-6	120	24.143	Flow (q) from Route 10
							0.004808		
3	13'-5		134.56	4.2600		12'-6		0.060	
								24.203	Total(Pt) Route 6
106	18'-5½	5.6	25.26	2	(See Notes)	10'-0	120	20.347	***** Route 7 ***** Sprinkler
							0.000000	-0.230	
103	18'-11½		0.04	2.1570		10'-0		0.000	
								20.117	Total(Pt) Route 7
108	19'-4½	5.6	25.29	2	(See Notes)	13'-0	120	20.392	***** Route 8 ***** Sprinkler
							0.010627	-0.299	
104	20'-1		34.44	2.1570		13'-0		0.138	
								20.231	Total(Pt) Route 8
109	19'-4½	5.6	25.29	2	(See Notes)	13'-0	120	20.400	***** Route 9 ***** Sprinkler
							0.010667	-0.299	
105	20'-1		34.51	2.1570		13'-0		0.139	
								20.240	Total(Pt) Route 9
110	18'-8	5.6	25.47	2	(See Notes)	13'-0	120	20.678	***** Route 10 ***** Sprinkler
							0.002666	0.299	
111	18'-0		16.31	2.1570		13'-0		0.035	
111	18'-0	5.6	25.67	2	(See Notes)	54'-11	120	21.012	Sprinkler, E(6'-2), PO(12'-3½)
						18'-5½	0.015327	1.981	
16	13'-5		41.98	2.1570		73'-4½		1.125	
16	13'-5		182.50	4		10'-0	120	24.118	Flow (q) from Route 1
							0.000557		
17	13'-5		41.98	4.2600		10'-0		0.006	
17	13'-5		41.93	4		9'-8	120	24.124	Flow (q) from Route 12
							0.002007		
15	13'-5		83.91	4.2600		9'-8		0.019	
								24.143	Total(Pt) Route 10

Pipe Information										
Node 1	Elev 1 (Foot)	K-Factor	Flow added this step (q)	Nominal ID	Fittings & Devices	Length (Foot)	C Factor	Total(Pt)	Notes	
										Node 2
110	18'-8	5.6	25.47	2	(See Notes)	13'-0	120	20.678 Route 11 Sprinkler	
108	19'-4½		9.15	2.1570			0.000916	-0.299		
						13'-0		0.012		
								20.392	Total(Pt) Route 11	
112	18'-8	5.6	25.47	2	(See Notes)	13'-0	120	20.687 Route 12 Sprinkler	
113	18'-0		16.25	2.1570			0.002648	0.299		
						13'-0		0.034		
113	18'-0	5.6	25.67	2	(See Notes)	54'-11	120	21.020	Sprinkler, E(6'-2), PO(12'-3½)	
							18'-5½	0.015290		1.981
17	13'-5		41.93	2.1570			73'-4½			1.122
								24.124	Total(Pt) Route 12	
112	18'-8	5.6	25.47	2	(See Notes)	13'-0	120	20.687 Route 13 Sprinkler	
							0.000928	-0.299		
109	19'-4½		9.22	2.1570			13'-0			0.012
								20.400	Total(Pt) Route 13	
18	13'-5		20.24	4		10'-0	120	24.903 Route 14 Flow (q) from Route 17	
19	13'-5		20.24	4.2600			10'-0	0.000144		0.001
19	13'-5		20.30	4		9'-7½	120	24.904	Flow (q) from Route 16	
20	13'-5		40.53	4.2600			9'-7½	0.000522		0.005
20	13'-5		20.50	4		12'-6	120	24.909	Flow (q) from Route 15	
21	13'-5		61.03	4.2600			12'-6	0.001114		0.014
21	13'-5		21.06	4		12'-6	120	24.923	Flow (q) from Route 19	
22	13'-5		82.09	4.2600			12'-6	0.001927		-0.000
								0.024		
22	13'-5		22.00	4	(See Notes)	10'-10	120	24.947	Flow (q) from Route 18 T(26'-4)	
							26'-4	0.002990		
9	13'-5		104.09	4.2600			37'-2			0.111
								25.058	Total(Pt) Route 14	

Pipe Information									
Node 1	Elev 1 (Foot)	K-Factor	Flow added this step (q)	Nominal ID	Fittings & Devices	Length (Foot)	C Factor	Total(Pt)	Notes Fitting/Device (Equivalent Length) Fixed Pressure Losses, when applicable, are added directly to (Pf) and shown as a negative value.
Node 2	Elev 2 (Foot)		Total Flow (Q)	Actual ID	Equiv. Length (Foot)	Fitting (Foot)	Pf Friction Loss Per Unit (psi)	Elev(Pe)	
						Total (Foot)		Friction(Pf)	
23	18'-6½		61.03	2	(See Notes)	97'-1	120	22.155	••••• Route 15 ••••• PO(12'-3½), Flow (q) from Route 20 2E(6'-2), PO(12'-3½)
20	13'-5		20.50	2.1570		36'-11	0.004070	2.209	
						134'-0		0.545	
								24.909	Total(Pt) Route 15
23	18'-6½		61.03	4		9'-7½	120	22.155	••••• Route 16 ••••• Flow (q) from Route 20
24	18'-6½		40.53	4.2600		9'-7½	0.000522	0.005	
24	18'-6½			2	(See Notes)	97'-1		120	22.160
19	13'-5		20.30	2.1570		36'-11	0.003995	2.209	
						134'-0		0.535	
								24.904	Total(Pt) Route 16
24	18'-6½		357.28	4		10'-0	120	22.160	••••• Route 17 ••••• Flow (q) from Route 1
25	18'-6½		20.24	4.2600		10'-0	0.000144	0.001	
25	18'-6½			2	(See Notes)	97'-1		120	22.162
18	13'-5		20.24	2.1570		36'-11	0.003973	2.209	
						134'-0		0.532	
								24.903	Total(Pt) Route 17
26	18'-6½		104.09	2	(See Notes)	97'-1	120	22.117	••••• Route 18 ••••• PO(12'-3½), Flow (q) from Route 23 2E(6'-2), PO(12'-3½)
22	13'-5		22.00	2.1570		36'-11	0.004637	2.209	
						134'-0		0.621	
								24.947	Total(Pt) Route 18
26	18'-6½		104.09	4		12'-6	120	22.117	••••• Route 19 ••••• Flow (q) from Route 23
27	18'-6½		82.09	4.2600		12'-6	0.001927	0.024	
27	18'-6½			2	(See Notes)	97'-1		120	22.141
21	13'-5		21.06	2.1570		36'-11	0.004278	2.209	
						134'-0		0.573	
								24.923	Total(Pt) Route 19
27	18'-6½		23.65	4		12'-6	120	22.141	••••• Route 20 ••••• Flow (q) from Route 5
23	18'-6½		61.03	4.2600		12'-6	0.001114	0.014	
								22.155	Total(Pt) Route 20

Pipe Information

Node 1	Elev 1 (Foot)	K-Factor	Flow added this step (q)	Nominal ID	Fittings & Devices	Length (Foot)	C Factor	Total(Pt)	Notes	
										Node 2
28	18'-6½		137.75	2	(See Notes)	97'-1	120	22.030		
7	13'-5		15.83	2.1570		36'-11	0.002522	2.209		
						134'-0		0.338		
								24.577	Total(Pt) Route 21	
28	18'-6½		137.75	4		12'-6	120	22.030	***** Route 22 ***** Flow (q) from Route 25	
29	18'-6½		121.92	4.2600		12'-6	0.004006	0.050		
29	18'-6½			2	(See Notes)	97'-1		120	22.080	PO(12'-3½) 2E(6'-2), PO(12'-3½)
8	13'-5		17.83	2.1570		36'-11	0.003145	2.209		
						134'-0		0.421		
								24.710	Total(Pt) Route 22	
29	18'-6½		97.80	4		12'-6	120	22.080	***** Route 23 ***** Flow (q) from Route 9	
26	18'-6½		104.09	4.2600		12'-6	0.002990	0.037		
								22.117	Total(Pt) Route 23	
30	18'-6½		165.97	2	(See Notes)	97'-1	120	21.892	***** Route 24 ***** PO(12'-3½), Flow (q) from Route 26 2E(6'-2), PO(12'-3½)	
5	13'-5		13.77	2.1570		36'-11	0.001950	2.209		
						134'-0		0.261		
								24.362	Total(Pt) Route 24	
30	18'-6½		165.97	4		12'-6	120	21.892	***** Route 25 ***** Flow (q) from Route 26	
31	18'-6½		152.20	4.2600		12'-6	0.006038	0.075		
31	18'-6½		146.32	4		12'-6		120	21.967	Flow (q) from Route 9
28	18'-6½		137.75	4.2600		12'-6	0.005021	0.063		
								22.030	Total(Pt) Route 25	
2	18'-6½		45.20	4		12'-6	120	21.700	***** Route 26 ***** Flow (q) from Route 1	
32	18'-6½		179.83	4.2600		12'-6	0.008221	0.103		
32	18'-6½		24.82	4		12'-6		120	21.803	Flow (q) from Route 14
30	18'-6½		165.97	4.2600		12'-6	0.007088	0.089		
								21.892	Total(Pt) Route 26	

Pipe Information

Node 1	Elev 1 (Foot)	K-Factor	Flow added this step (q)	Nominal ID	Fittings & Devices	Length (Foot)	C Factor	Total(Pt)	Notes Fitting/Device (Equivalent Length) Fixed Pressure Losses, when applicable, are added directly to (Pf) and shown as a negative value.
31	18'-6½			2	(See Notes)	97'-1	120	21.967	
6	13'-5		14.45	2.1570		36'-11	0.002130	2.209	
						134'-0		0.285	
								24.461	Total(Pt) Route 27
32	18'-6½			2	(See Notes)	97'-1	120	21.803	
4	13'-5		13.85	2.1570		36'-11	0.001971	2.209	
						134'-0		0.264	
								24.276	Total(Pt) Route 28

Equivalent Pipe Lengths of Valves and Fittings (C=120 only)

C Value Multiplier

$$\left(\frac{\text{Actual Inside Diameter}}{\text{Schedule 40 Steel Pipe Inside Diameter}} \right)^{4.87} = \text{Factor}$$

Value Of C	100	130	140	150
Multiplying Factor	0.713	1.16	1.33	1.51

Fittings Legend

ALV Alarm Valve	AngV Angle Valve	b Bushing
BaIV Ball Valve	BFP Backflow Preventer	BV Butterfly Valve
C Cross Flow Turn 90°	cplg Coupling	Cr Cross Run
CV Check Valve	DelV Deluge Valve	DPV Dry Pipe Valve
E 90° Elbow	EE 45° Elbow	Ee1 11¼° Elbow
Ee2 22½° Elbow	f Flow Device	fd Flex Drop
FDC Fire Department Connection	fE 90° FireLock(TM) Elbow	fEE 45° FireLock(TM) Elbow
flg Flange	FN Floating Node	fT FireLock(TM) Tee
g Gauge	GloV Globe Valve	GV Gate Valve
Ho Hose	Hose Hose	HV Hose Valve
Hyd Hydrant	LtE Long Turn Elbow	mecT Mechanical Tee
Noz Nozzle	P1 Pump In	P2 Pump Out
PIV Post Indicating Valve	PO Pipe Outlet	PrV Pressure Relief Valve
PRV Pressure Reducing Valve	red Reducer/Adapter	S Supply
sCV Swing Check Valve	SFx Seismic Flex	Spr Sprinkler
St Strainer	T Tee Flow Turn 90°	Tr Tee Run
U Union	WirF Wirsbo	WMV Water Meter Valve
Z Cap		