

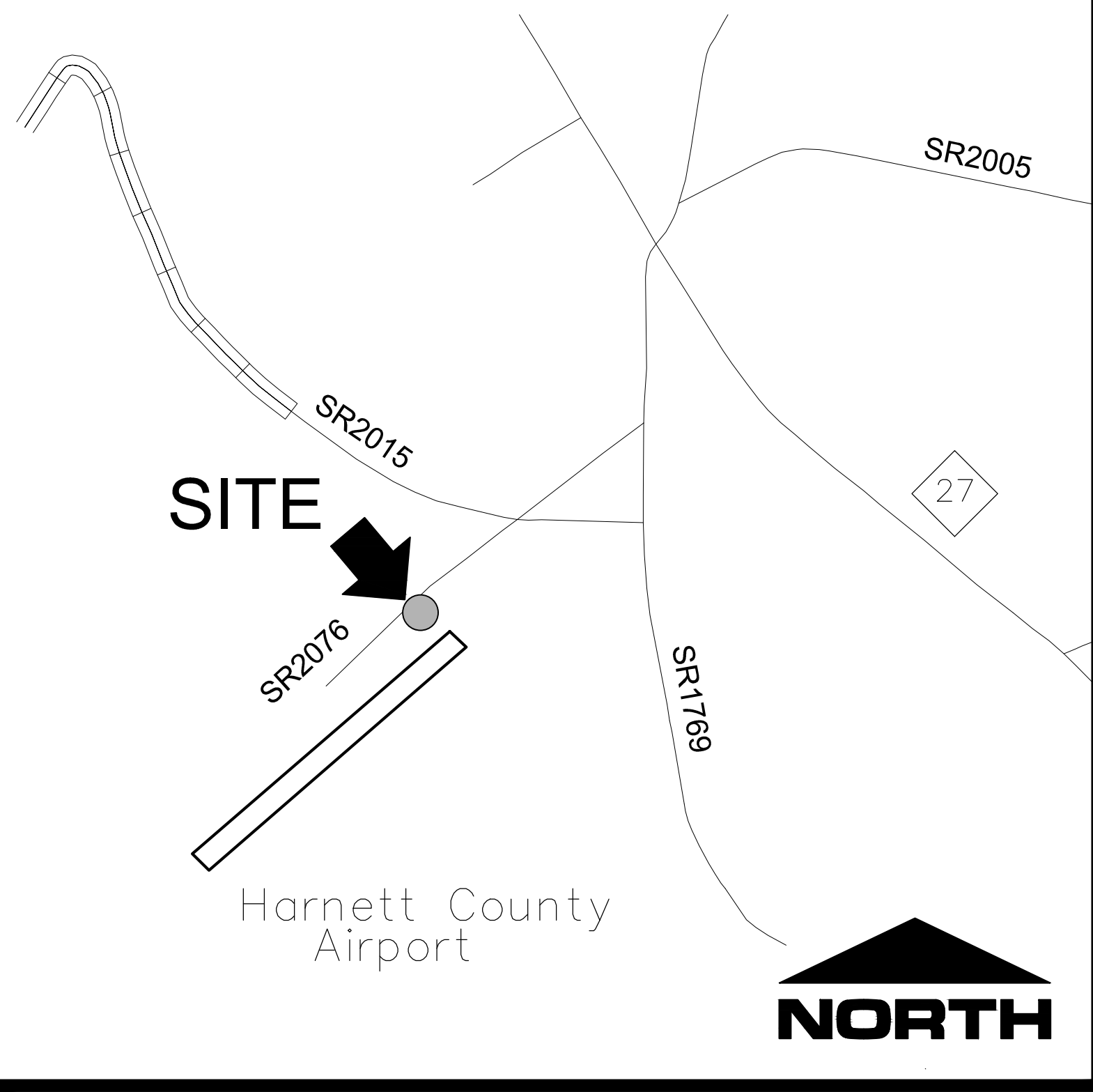

# AIRPORT ROAD HANGAR SITE DEVELOPMENT PLANS

NEILL'S CREEK TOWNSHIP  
 NEAR ERWIN, NORTH CAROLINA  
 HARNETT COUNTY

AIRPORT ROAD - SR 2076  
 70' PUBLIC ROW



**VICINITY MAP**  
 NOT TO SCALE

## EXISTING UTILITY OWNER

### WATER

HARNETT REGIONAL WATER  
 700 McKinney Parkway  
 Lillington, North Carolina 27546  
 910-893-7575  
 Contact: Katherine Moore



Know what's below.  
 Call before you dig.

## INDEX OF DRAWINGS

- G1.0 - PROJECT NOTES
- C1.0 - EXISTING CONDITIONS
- C2.0 - SITE PLAN
- C3.0 - GRADING AND EROSION CONTROL PLAN
- C4.0 - UTILITY PLAN
- C5.0 - SITE & EC DETAILS
- C5.1 - WATER DETAILS

**CIVIL ENGINEER**  
 4D SITE SOLUTIONS, INC.  
 409 Chicago Drive - Suite 112  
 Fayetteville, North Carolina 28306  
 910-426-6777  
 Contact: Scott Brown, PE  
 email: sbrown@4dsitesolutions.com

**OWNER/DEVELOPER**  
 BRIAN RAYNOR  
 2031 Middle Road  
 Fayetteville, North Carolina 27312  
 910-824-1238  
 Contact: Brian Raynor  
 email: braynor@highlandpaving.com

**SURVEYOR**  
 REGIONAL LAND SURVEYORS, INC  
 8642 West Market Street, Suite 100  
 Greensboro, North Carolina 27409  
 910-336-665-8155  
 Contact: David Clark, PLS  
 email: aclark@regionallandsurveyors.com

REVISIONS

PROJECT NAME

**AIRPORT  
 ROAD  
 HANGAR**

PIN: 0579-82-7353.000  
 AIRPORT ROAD  
 NEILL'S CREEK TOWNSHIP  
 NEAR ERWIN  
 HARNETT COUNTY  
 NORTH CAROLINA

CLIENT

**BRIAN RAYNOR**

2031 Middle Road  
 Fayetteville, NC 28312  
 Phone: (910) 824-1238  
 Fax: (910) 678-9988

PROJECT INFORMATION

DESIGNED BY:	SCOTT
DRAWN BY:	SCOTT
CHECKED BY:	CHRIS
PROJECT NUMBER:	1942

DRAWING SCALE

SEE SHEETS

DATE RELEASED

OCTOBER 16, 2023

THE CONTRACTOR MUST CONTACT NORTH CAROLINA ONE CALL CENTER AT 1-800-632-4949 A MINIMUM OF 72 HOURS PRIOR TO DIGGING IN ORDER TO HAVE THE EXISTING UTILITIES LOCATED

I:\Users\scottb\OneDrive\Documents\4D Site Solutions\2023\10-16-23\1942.dwg



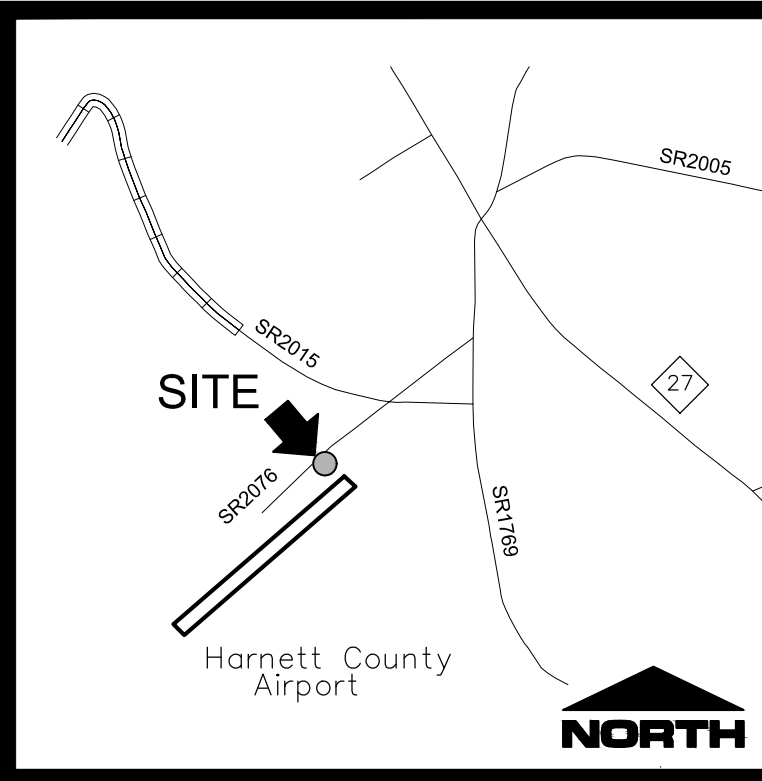

VICINITY MAP  
NOT TO SCALE

PID 110579 0153  
 REID 0579-74-2525.000  
 THE MUELLER-TOWNSEND  
 LLC  
 DB 2456 PG 85  
 PROPOSED ACQUISITION AREA  
 FROM MUELLER-TOWNSEND  
 97.26 ACRES

- LEGEND:  
 ERS-EXISTING RAILROAD SPIKE  
 EIR-EXISTING IRON ROD  
 SIR-SET IRON ROD  
 SIP-SET IRON PIPE  
 COMPUTED POINT  
 N/F - NOW OR FORMERLY  
 R/W - RIGHT OF WAY  
 PROPERTY LINE  
 OLD PROPERTY LINE  
 TIE LINE  
 RIGHT-OF-WAY  
 SETBACK LINE  
 STORM DRAINAGE  
 WATER LINE  
 OVERHEAD UTILITY  
 TREE LINE  
 MAJOR CONTOUR  
 MINOR CONTOUR  
 SPOT ELEVATION  
 BENCHMARK  
 UTILITY POLE  
 GUY WIRE  
 LIGHT POLE

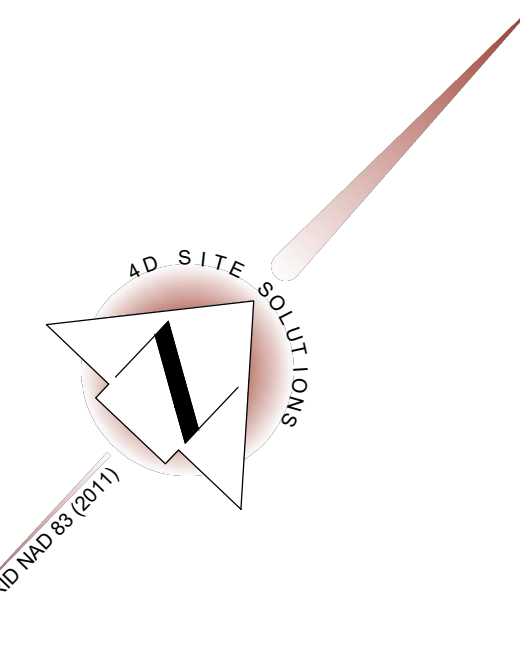
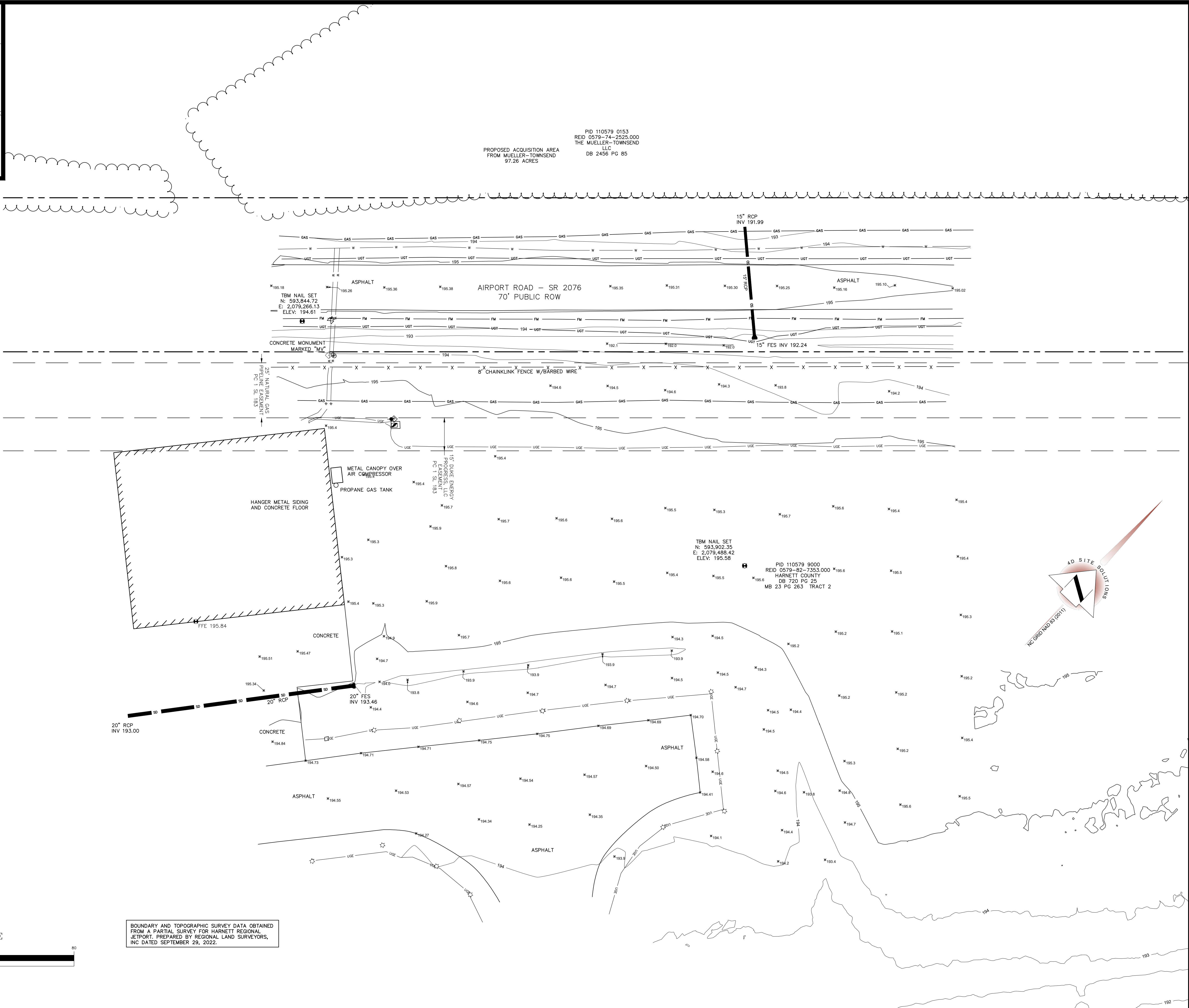

REVISIONS

PROJECT NAME

**AIRPORT ROAD HANGAR**

EXISTING CONDITIONS

CLIENT

**BRIAN RAYNOR**

2031 Middle Road  
 Fayetteville, NC 28312  
 Phone: (910) 824-1238  
 Fax: (910) 678-9988

PROJECT INFORMATION

DESIGNED BY:	SCOTT
DRAWN BY:	SCOTT
CHECKED BY:	CHRIS
PROJECT NUMBER:	1942

DRAWING SCALE

HORIZONTAL: 1"=20'

DATE RELEASED

OCTOBER 16, 2023

SHEET NUMBER

**C-1.0**

BOUNDARY AND TOPOGRAPHIC SURVEY DATA OBTAINED FROM A PARTIAL SURVEY FOR HARNETT REGIONAL JEPPORT, PREPARED BY REGIONAL LAND SURVEYORS, INC DATED SEPTEMBER 29, 2022.

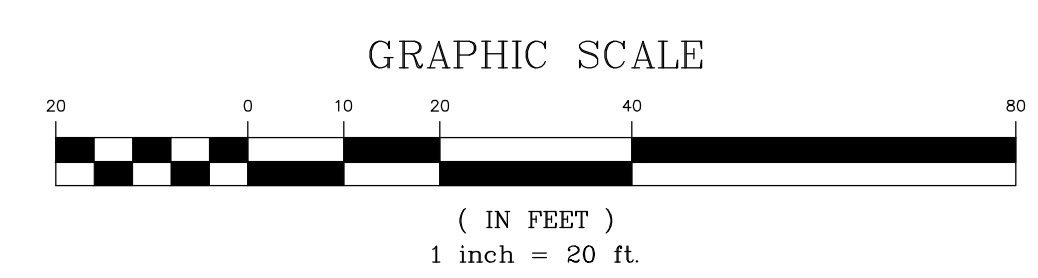

Brian Raynor 1942.dwg 10/16/23 10:52:41 AM 30 2000 10/16/23 10:52:41 AM 40 11.0 10/16/23 10:52:41 AM

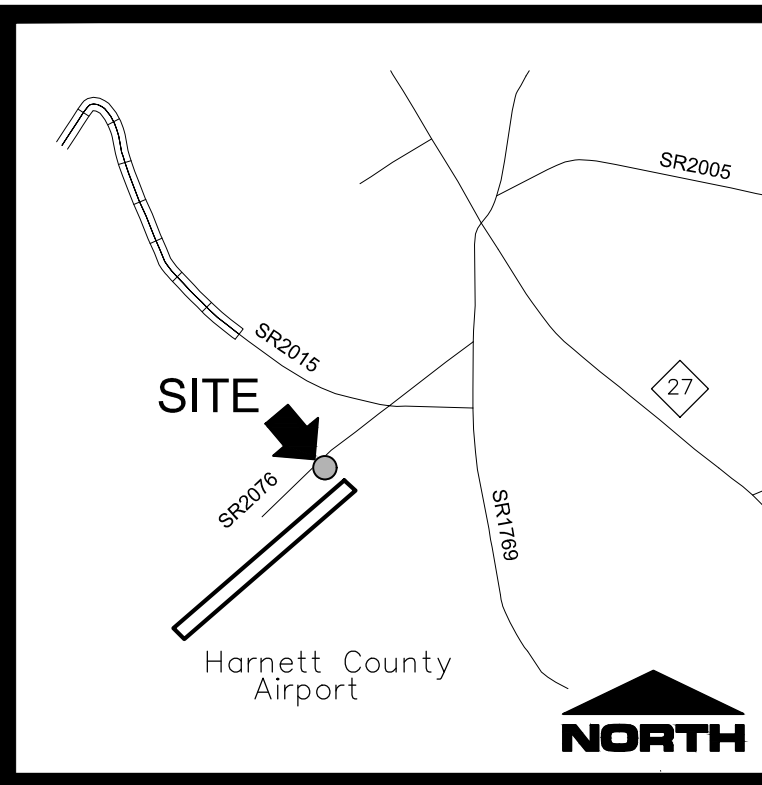

VICINITY MAP  
NOT TO SCALE

QTY.	TYPE	PLANTING SIZE	MIN. HEIGHT	SCIENTIFIC NAME
UNDERSTORY TREES				
2	WILLOW OAK	2" CALIPER	6'	QUERCUS PHellos

LANDSCAPING NOTES:

- HEIGHT AND SPREAD OF TREE SPECIMEN SHALL MEET REQUIREMENTS OF THE AMERICAN ASSOCIATION OF NURSERYMEN, AMERICAN STANDARD FOR NURSERY STOCK.
- SITE LIGHTING PLANS REQUIRE LIGHTS TO BE A MIN. OF 15 FEET FROM TREES. ANY ADJUSTMENTS IN THE FIELD NEED TO COMPLY WITH THIS STANDARD AND BE APPROVED BY COUNTY STAFF.
- EACH TREE MUST BE PLANTED SUCH THAT THE ROOT FLARE IS VISIBLE AT THE TOP OF THE ROOT BALL. TREES WHERE THE ROOT FLARE IS NOT VISIBLE SHALL BE REJECTED. DO NOT COVER THE ROOT FLARE WITH MULCH.
- DO NOT PLACE MULCH IN CONTACT WITH THE TREE TRUNK. KEEP MULCH A MIN. OF 4" AWAY FROM THE TRUNK BASE.
- ANY CHANGES TO THE PROPOSED PLANT SCHEDULE MUST BE APPROVED BY THE DESIGNER OF RECORD AND THE COUNTY. IN CASES WHERE THE PLANT SCHEDULE ONLY INCLUDES THE PLANT TYPE AND DOES NOT INCLUDE THE PLANT SPECIES, THE CONTRACTOR SHALL BE REQUIRED TO SUBMIT TO THE COUNTY FOR APPROVAL, A DETAILED PLANT SCHEDULE AND ASSOCIATED PLANTING PLAN PREPARED BY A PROFESSIONAL KNOWLEDGEABLE ABOUT PLANT MATERIAL AND DESIGN, PRIOR TO PROCEEDING WITH INSTALLATION.

\*THIS LANDSCAPING PLAN IS THE MINIMUM REQUIRED TO MEET WITH HARNETT COUNTY ZONING ORDINANCE. THE OWNER OR DEVELOPER IS ENCOURAGED TO CONSULT WITH A LANDSCAPE ARCHITECT IN ORDER TO DEVELOP A PLAN THAT IS MORE IN DEPTH THAN THE MINIMUM REQUIREMENTS. THIS PLAN IS FOR PERMITTING PURPOSES ONLY.



REVISIONS

PROJECT NAME

**AIRPORT ROAD HANGAR**

SITE PLAN

CLIENT

**BRIAN RAYNOR**

2031 Middle Road  
Fayetteville, NC 28312  
Phone: (910) 824-1238  
Fax: (910) 678-9988

PROJECT INFORMATION

DESIGNED BY:	SCOTT
DRAWN BY:	SCOTT
CHECKED BY:	CHRIS
PROJECT NUMBER:	1942

DRAWING SCALE

HORIZONTAL: 1"=20'

DATE RELEASED

OCTOBER 16, 2023

SHEET NUMBER

**C-2.0**

- LEGEND:
- ERS-EXISTING RAILROAD SPIKE
  - EIR-EXISTING IRON ROD
  - SIR-SET IRON ROD
  - SIP-SET IRON PIPE
  - COMPUTED POINT
  - N/F - NOW OR FORMERLY
  - R/W - RIGHT OF WAY
  - PROPERTY LINE
  - OLD PROPERTY LINE
  - TIE LINE
  - RIGHT-OF-WAY
  - SETBACK LINE
  - STORM DRAINAGE
  - WATER LINE
  - OVERHEAD UTILITY
  - TREE LINE
  - MAJOR CONTOUR
  - MINOR CONTOUR
  - SPOT ELEVATION
  - BENCHMARK
  - UTILITY POLE
  - GUY WIRE
  - LIGHT POLE

SITE NOTES

- EXISTING UNDERGROUND UTILITIES ARE SHOWN ONLY WHERE EVIDENCE COULD BE FOUND TO VERIFY LOCATION. PRIOR TO CONSTRUCTION OR EXCAVATION OF THE SITE, THE GENERAL CONTRACTOR SHALL CONTACT ALL UTILITY COMPANIES TO VERIFY THE LOCATION OF THEIR RESPECTIVE UTILITIES. ALL DAMAGE INCURRED TO EXISTING UTILITIES DURING CONSTRUCTION SHALL BE REPAIRED AT THE GENERAL CONTRACTOR'S EXPENSE.
- ASPHALT AND BASE TYPE SHALL BE PER THE DETAILS.
- HANDICAP RAMPS, SIGNAGE AND PARKING SPACES SHALL BE PROVIDED BY THE CONTRACTOR AND INSTALLED PER FEDERAL ADA AND LOCAL REQUIREMENTS.
- ALL DIMENSIONS ARE TO THE BACK OF CURB OR TO THE FACE OF SIDEWALK UNLESS OTHERWISE NOTED.
- ALL RADII ARE 5' UNLESS OTHERWISE NOTED.
- PARKING STALLS MUST BE STRIPED WITH A 4 INCH CONTRASTING STRIPE (YELLOW ON CONCRETE AND YELLOW OR WHITE ON ASPHALT PARKING LOT).
- HANDICAP PARKING SPACES ARE TO BE DESIGNATED BY BLUE STRIPING AND EITHER A BLUE SYMBOL ON A WHITE BACKGROUND OR A WHITE SYMBOL ON A BLUE BACKGROUND. ALL HANDICAP PARKING STALLS REQUIRE THE INSTALLATION OF THE PROPER SIGNAGE.
- ALL PARKING SPACES ARE TO BE LAID OUT IN ACCORDANCE WITH THE SITE PLAN DIMENSIONS.
- ALL WASTE MATERIAL SHALL BE DISPOSED OF OFF-SITE IN ACCORDANCE WITH STATE AND LOCAL LAWS AND REGULATIONS.
- ALL SITE IMPROVEMENTS SHALL BE INSTALLED PER HARNETT COUNTY AND STATE REGULATIONS.

SITE DATA

DEVELOPER	BRIAN RAYNOR
MAILING ADDRESS	2031 MIDDLE ROAD
CITY, STATE	FAYETTEVILLE, NORTH CAROLINA 28312
PIN NUMBER	0579-82-7353.000
TOTAL LOT AREA	0.74 AC
AREA TO BE DEVELOPED	0.74 AC
EXISTING ZONING	INDUSTRIAL
EXISTING USE	AIRPORT VACANT PARCEL
PROPOSED USE	HANGAR
DISTURBED/DENUDED AREA	0.97 AC
<b>SETBACKS REQUIRED:</b>	
FRONT	25
SIDE	0
REAR	25
<b>PARKING:</b>	
REQUIRED (INCLUDING HANDICAP)	XX
PROPOSED (INCLUDING HANDICAP)	7
PROPOSED HC SPACES	1

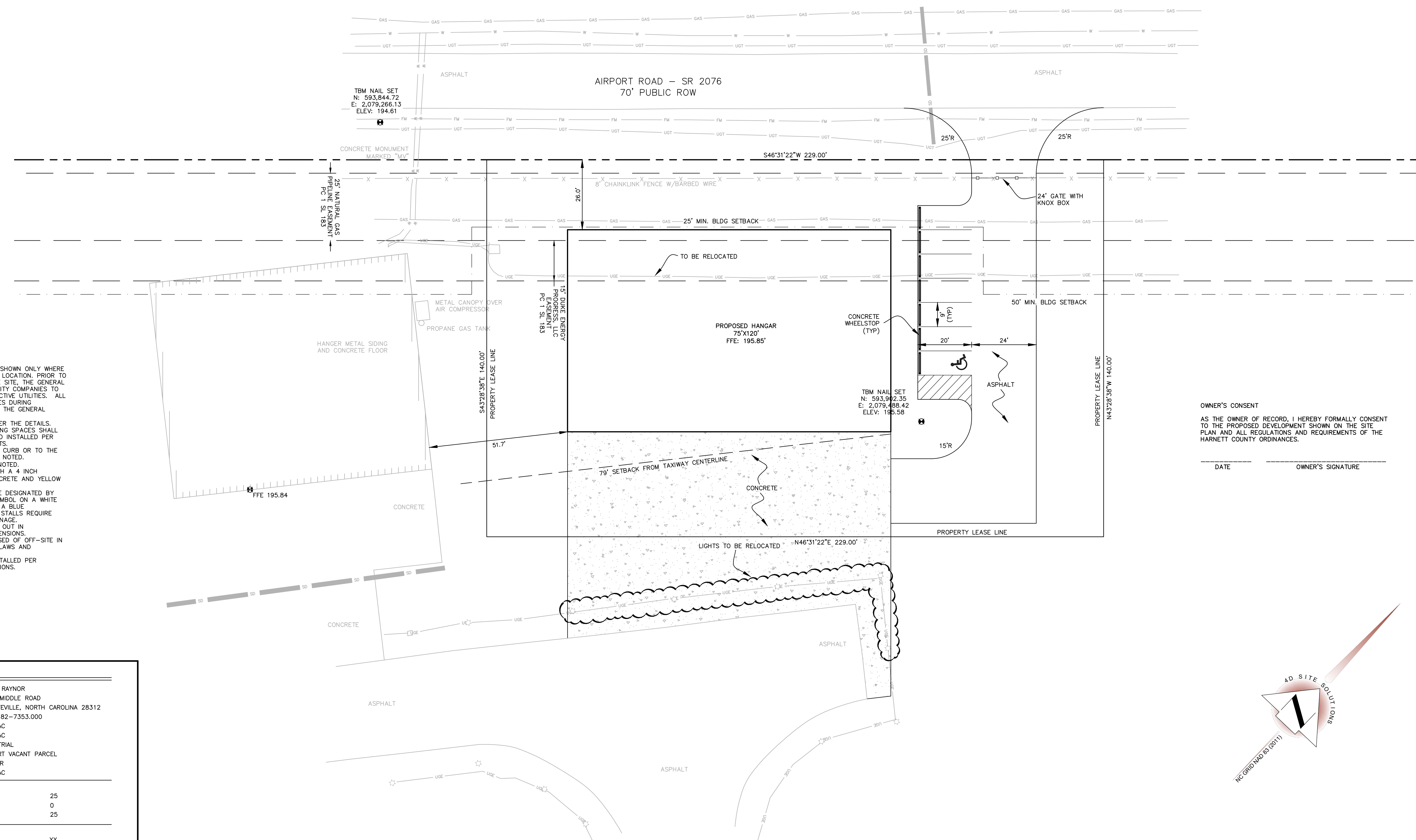

OWNER'S CONSENT  
AS THE OWNER OF RECORD, I HEREBY FORMALLY CONSENT TO THE PROPOSED DEVELOPMENT SHOWN ON THE SITE PLAN AND ALL REGULATIONS AND REQUIREMENTS OF THE HARNETT COUNTY ORDINANCES.

DATE \_\_\_\_\_ OWNER'S SIGNATURE \_\_\_\_\_

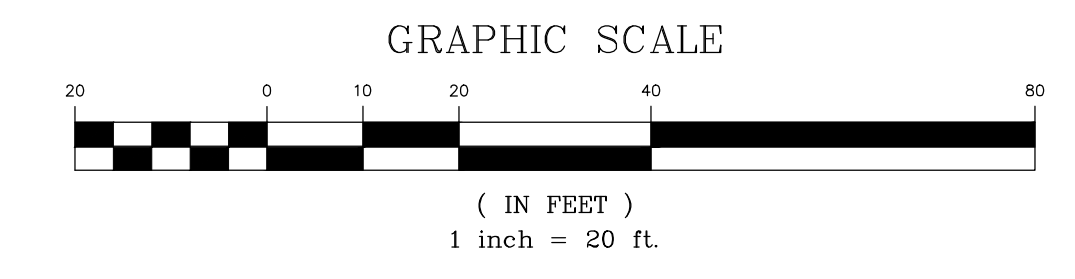

B: Brian Raynor 10/16/23 10:45 AM 409 Chicago Drive, Suite 112, Fayetteville, NC 28304 910-426-6777 910-426-5777 www.4dsitesolutions.com



REVISIONS

PROJECT NAME

**AIRPORT ROAD HANGAR**

**GRADING AND EROSION CONTROL PLAN**

CLIENT

**BRIAN RAYNOR**

2031 Middle Road  
 Fayetteville, NC 28312  
 Phone: (910) 824-1238  
 Fax: (910) 678-9988

PROJECT INFORMATION

DESIGNED BY:	SCOTT
DRAWN BY:	SCOTT
CHECKED BY:	CHRIS
PROJECT NUMBER:	1942

DRAWING SCALE

HORIZONTAL: 1"=20'

DATE RELEASED

OCTOBER 16, 2023

SHEET NUMBER

**C-3.0**

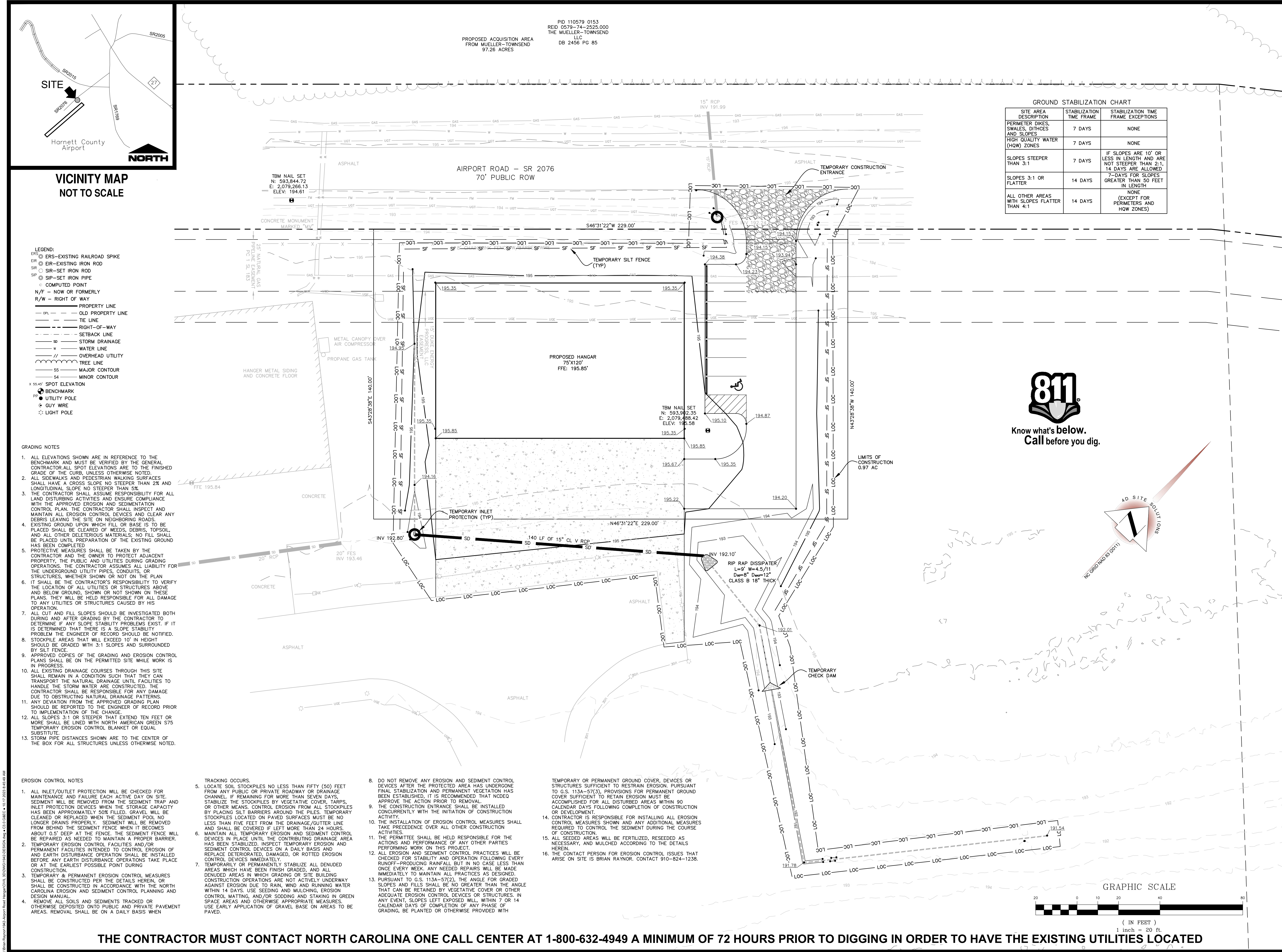

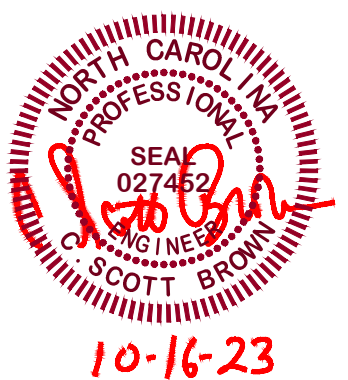

REVISIONS

PROJECT NAME

**AIRPORT ROAD HANGAR**

**UTILITY PLAN**

PIN:

CLIENT

**BRIAN RAYNOR**

2031 Middle Road  
Fayetteville, NC 28312  
Phone: (910) 824-1238  
Fax: (910) 678-9988

PROJECT INFORMATION

DESIGNED BY:	SCOTT
DRAWN BY:	SCOTT
CHECKED BY:	CHRIS
PROJECT NUMBER:	1942

DRAWING SCALE

HORIZONTAL: 1"=20'

DATE RELEASED

OCTOBER 16, 2023

SHEET NUMBER

**C-4.0**

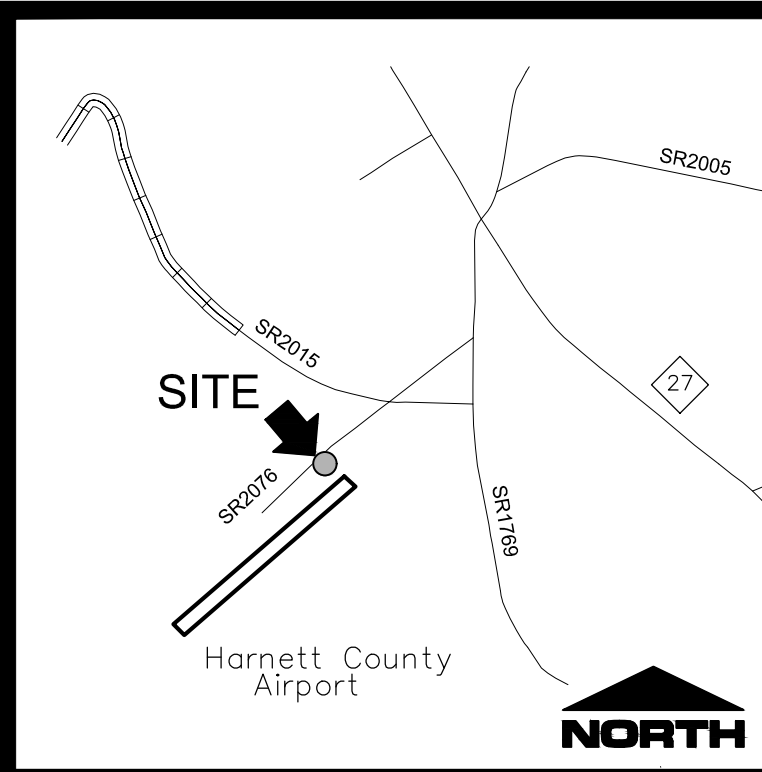

**VICINITY MAP  
NOT TO SCALE**

PID 110579 0153  
REID 0579-74-2525.000  
THE MUELLER-TOWNSEND  
LLC  
DB 2456 PG 85

PROPOSED ACQUISITION AREA  
FROM MUELLER-TOWNSEND  
97.26 ACRES

- LEGEND:
- ERS-EXISTING RAILROAD SPIKE
  - EIR-EXISTING IRON ROD
  - SIR-SET IRON ROD
  - SIP-SET IRON PIPE
  - COMPUTED POINT
  - N/F - NOW OR FORMERLY
  - R/W - RIGHT OF WAY
  - PROPERTY LINE
  - OLD PROPERTY LINE
  - TIE LINE
  - RIGHT-OF-WAY
  - SETBACK LINE
  - STORM DRAINAGE
  - WATER LINE
  - OVERHEAD UTILITY
  - TREE LINE
  - MAJOR CONTOUR
  - MINOR CONTOUR
  - SPOT ELEVATION
  - BENCHMARK
  - UTILITY POLE
  - GUY WIRE
  - LIGHT POLE

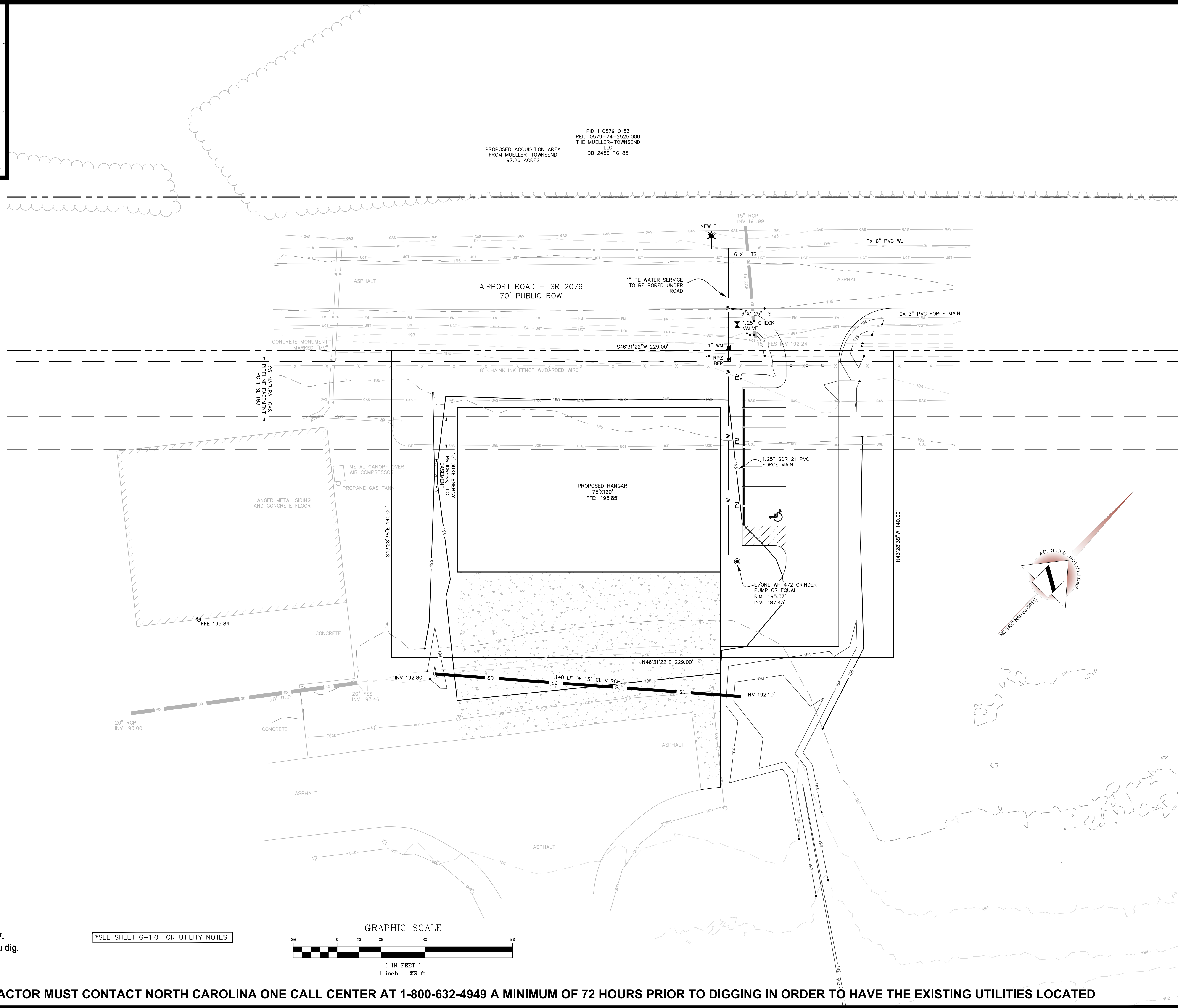

Know what's below.  
Call before you dig.

\*SEE SHEET G-1.0 FOR UTILITY NOTES

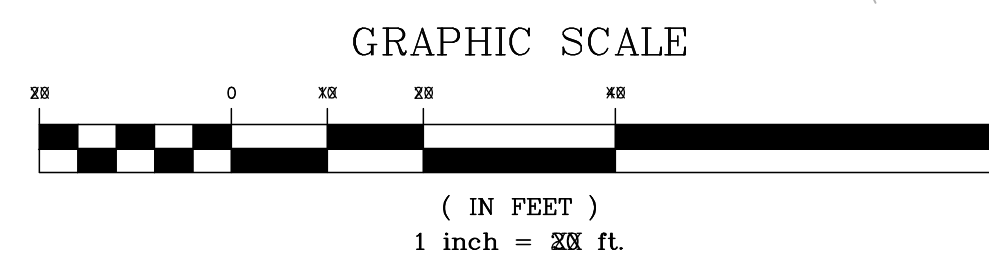

**THE CONTRACTOR MUST CONTACT NORTH CAROLINA ONE CALL CENTER AT 1-800-632-4949 A MINIMUM OF 72 HOURS PRIOR TO DIGGING IN ORDER TO HAVE THE EXISTING UTILITIES LOCATED**

D:\Projects\1942\BRIAN RAYNOR\1942-AIRPORT HANGAR\1942-AIRPORT HANGAR.dwg 10/16/23 8:48:19 AM



REVISIONS

PROJECT NAME

**AIRPORT ROAD HANGAR**

**SITE & EROSION CONTROL DETAILS**

CLIENT

**BRIAN RAYNOR**

2031 Middle Road  
 Fayetteville, NC 28312  
 Phone: (910) 824-1238  
 Fax: (910) 678-9988

PROJECT INFORMATION

DESIGNED BY:	SCOTT
DRAWN BY:	SCOTT
CHECKED BY:	CHRIS
PROJECT NUMBER:	1942

DRAWING SCALE

NOT TO SCALE

DATE RELEASED

OCTOBER 16, 2023

SHEET NUMBER

**C-5.0**

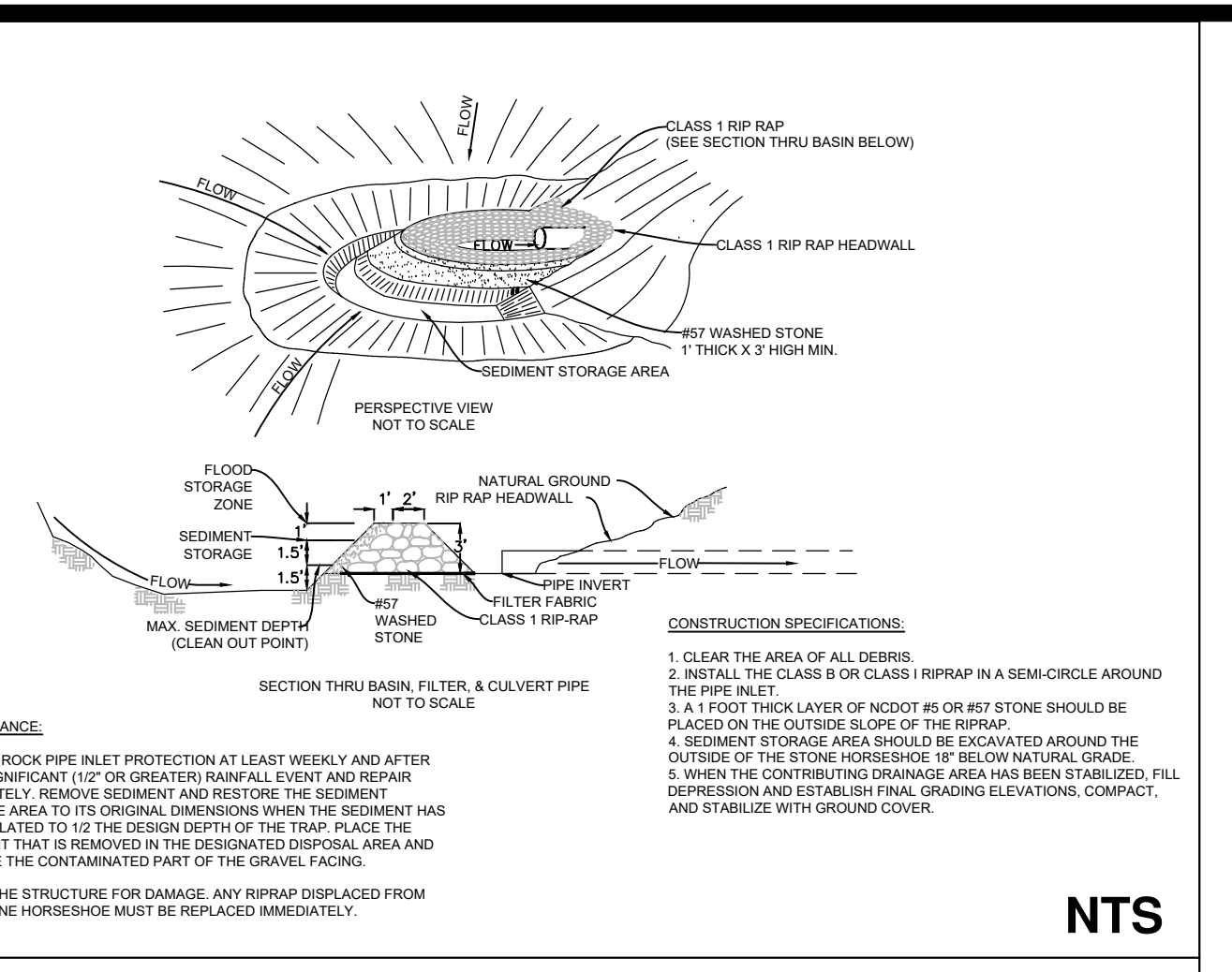

**4 ROCK PIPE INLET PROTECTION**

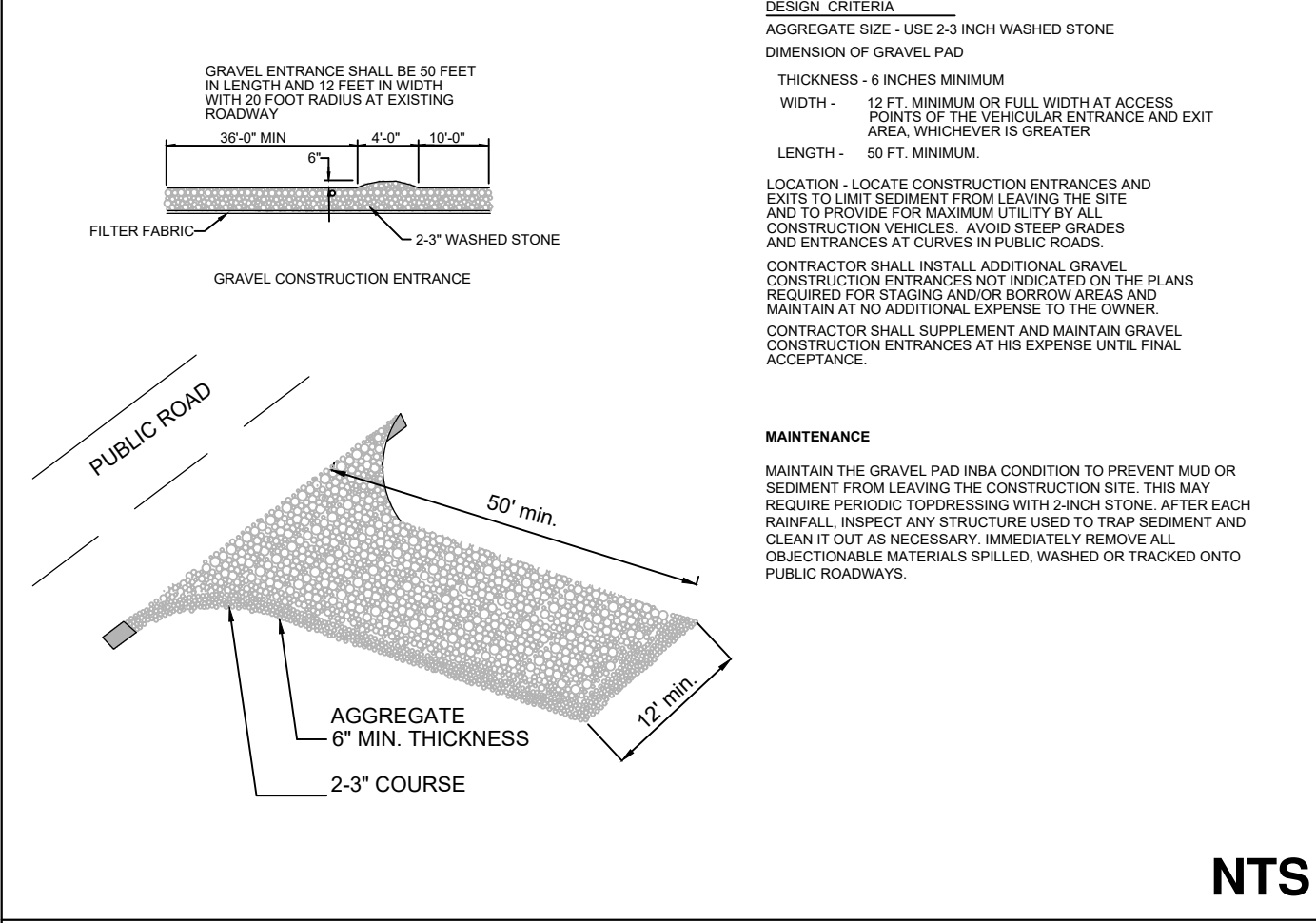

**7 TEMPORARY GRAVEL CONSTRUCTION ENTRANCE**

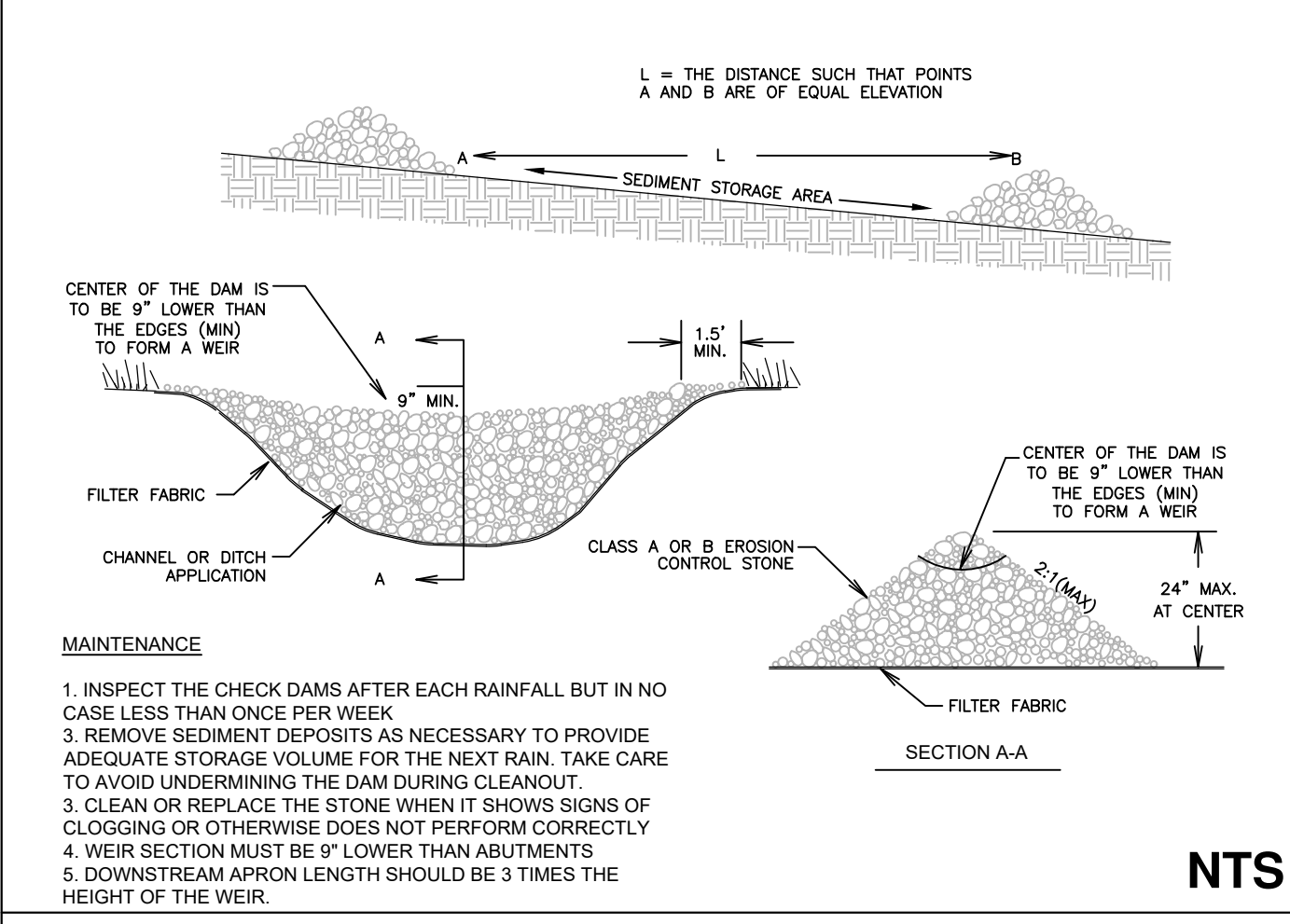

**11 CHECK DAM WITH WEIR**

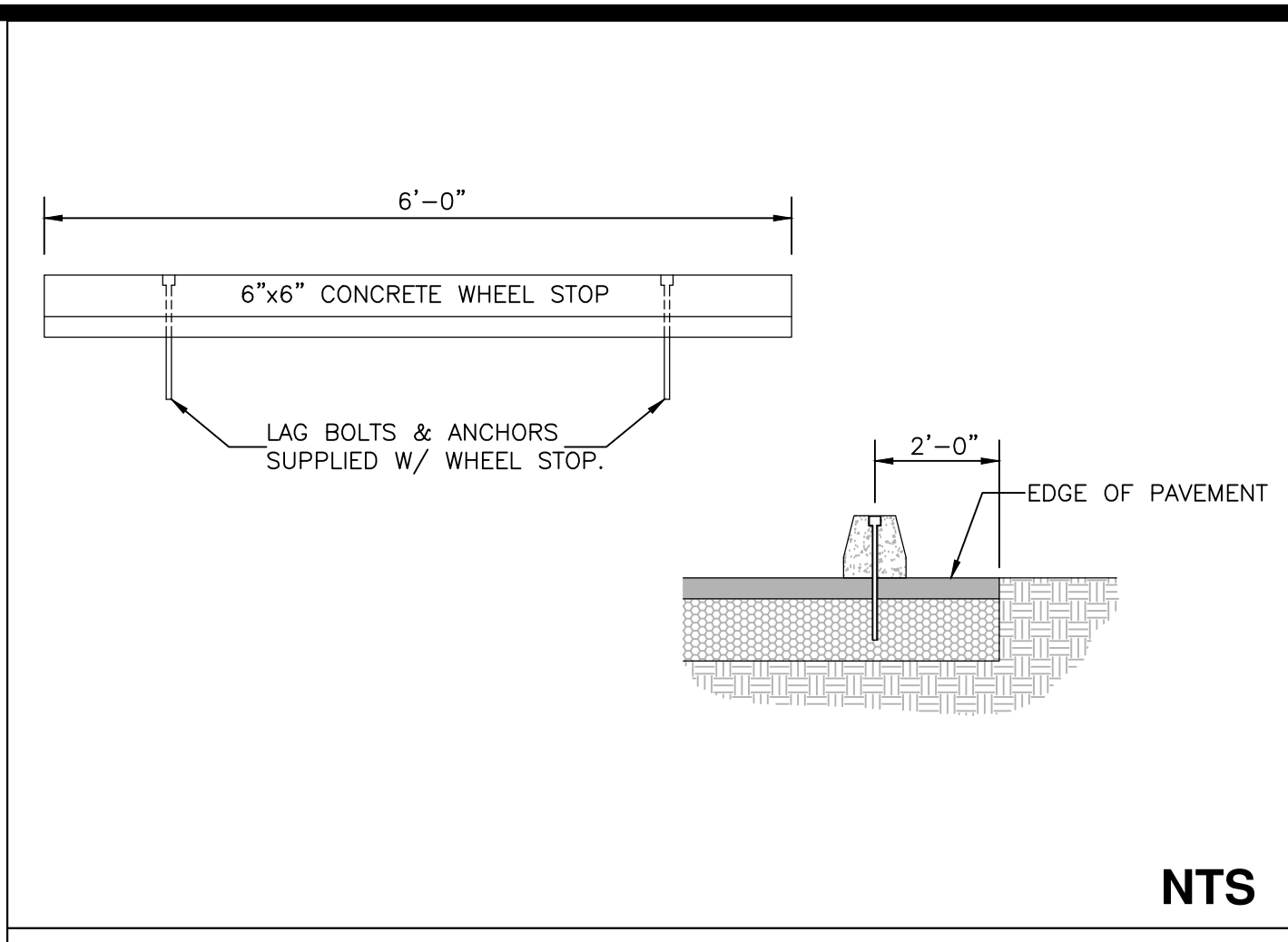

**3 CONCRETE WHEEL STOP**

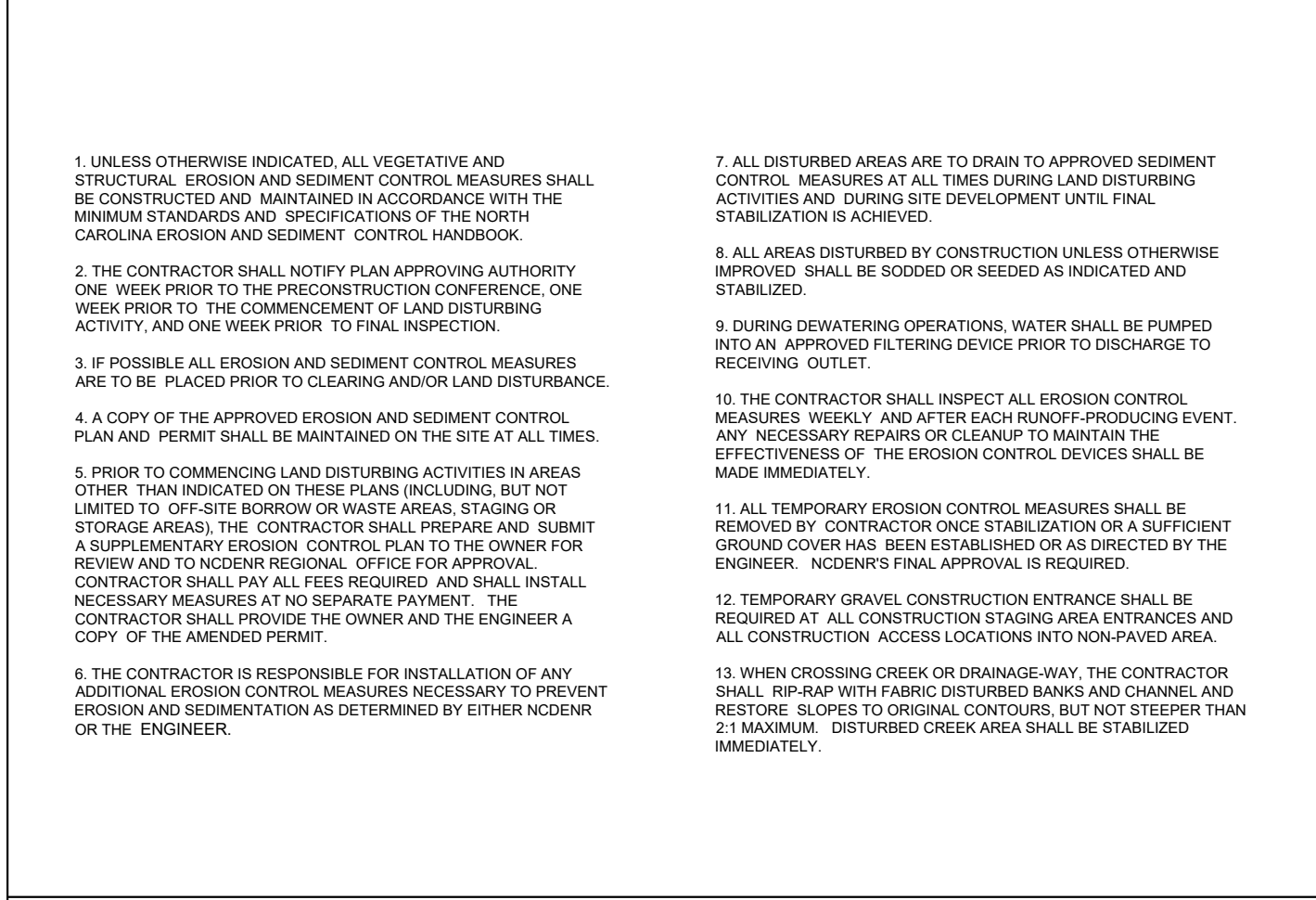

**6 GENERAL EROSION AND SEDIMENT CONTROL NOTES**

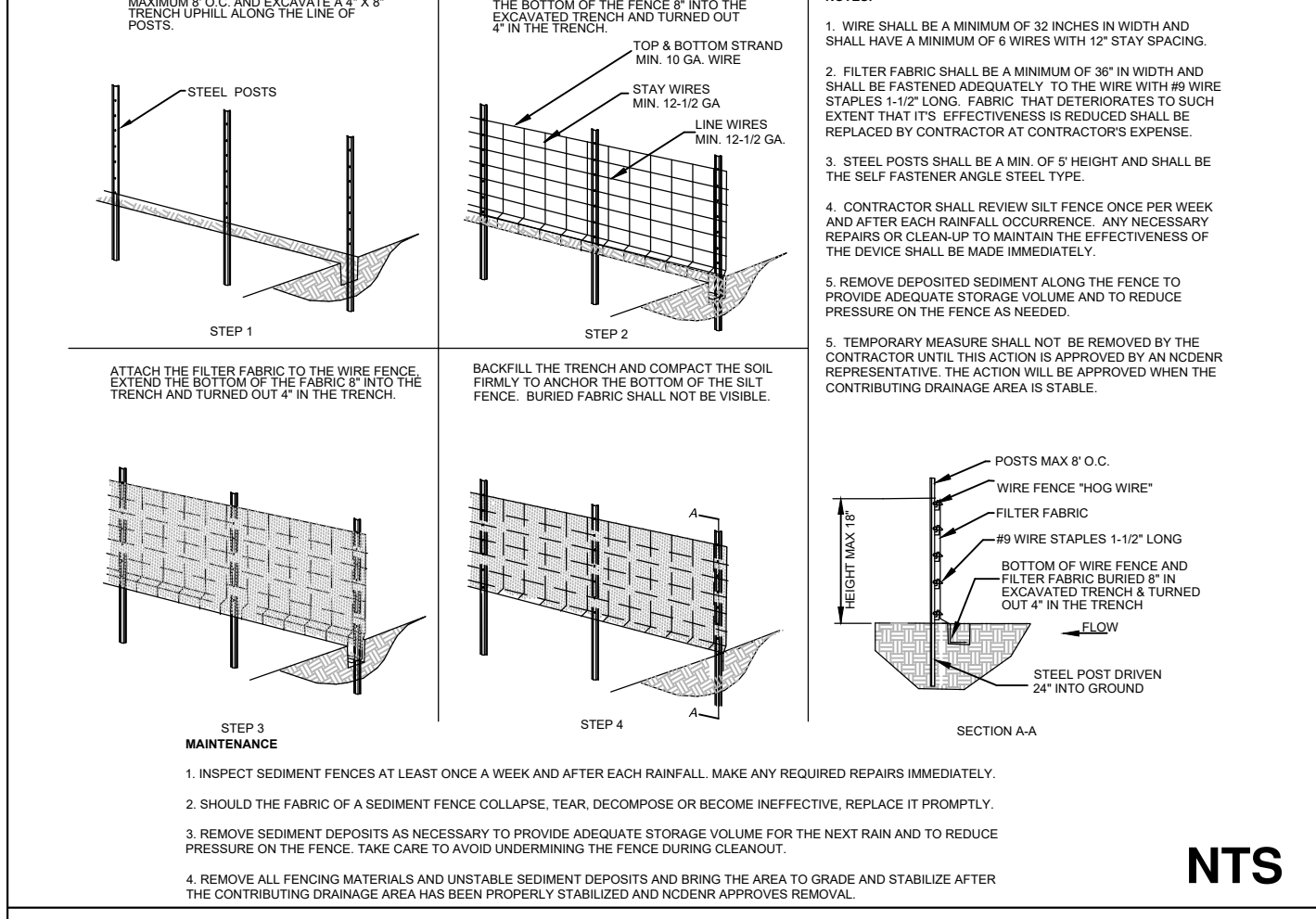

**10 SILT FENCE**

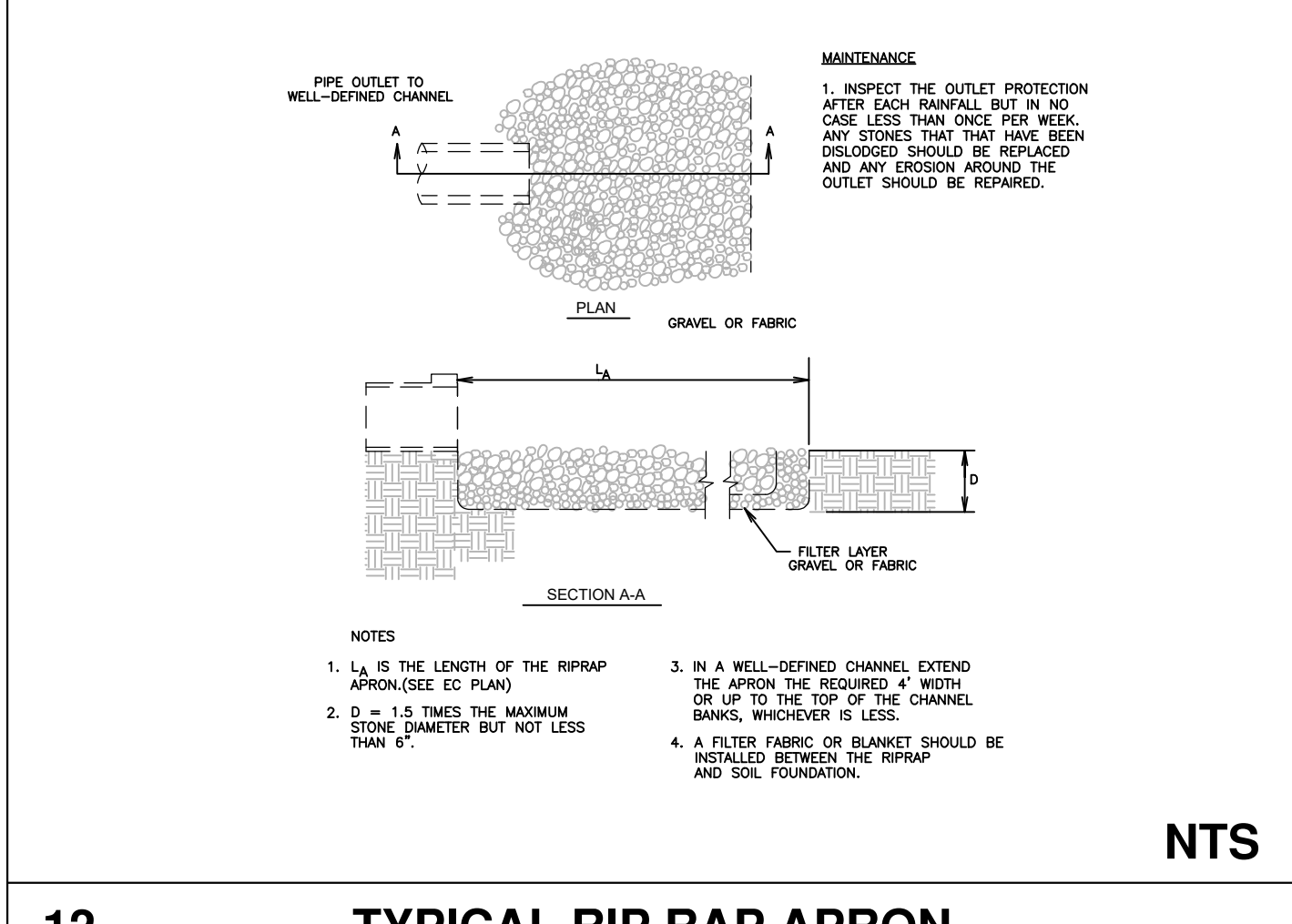

**12 TYPICAL RIP RAP APRON**

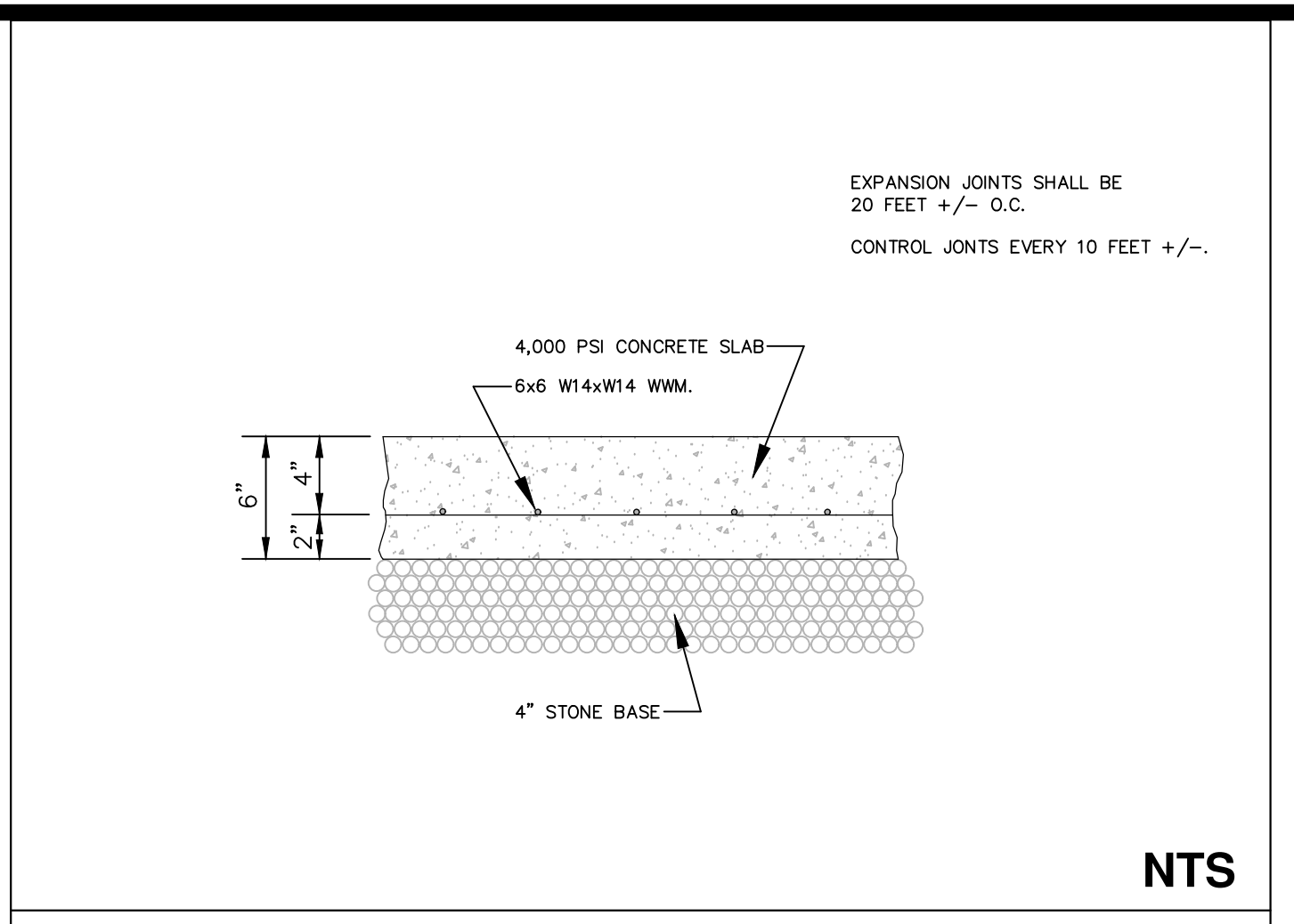

**2 CONCRETE DRIVE PAVEMENT SECTION**

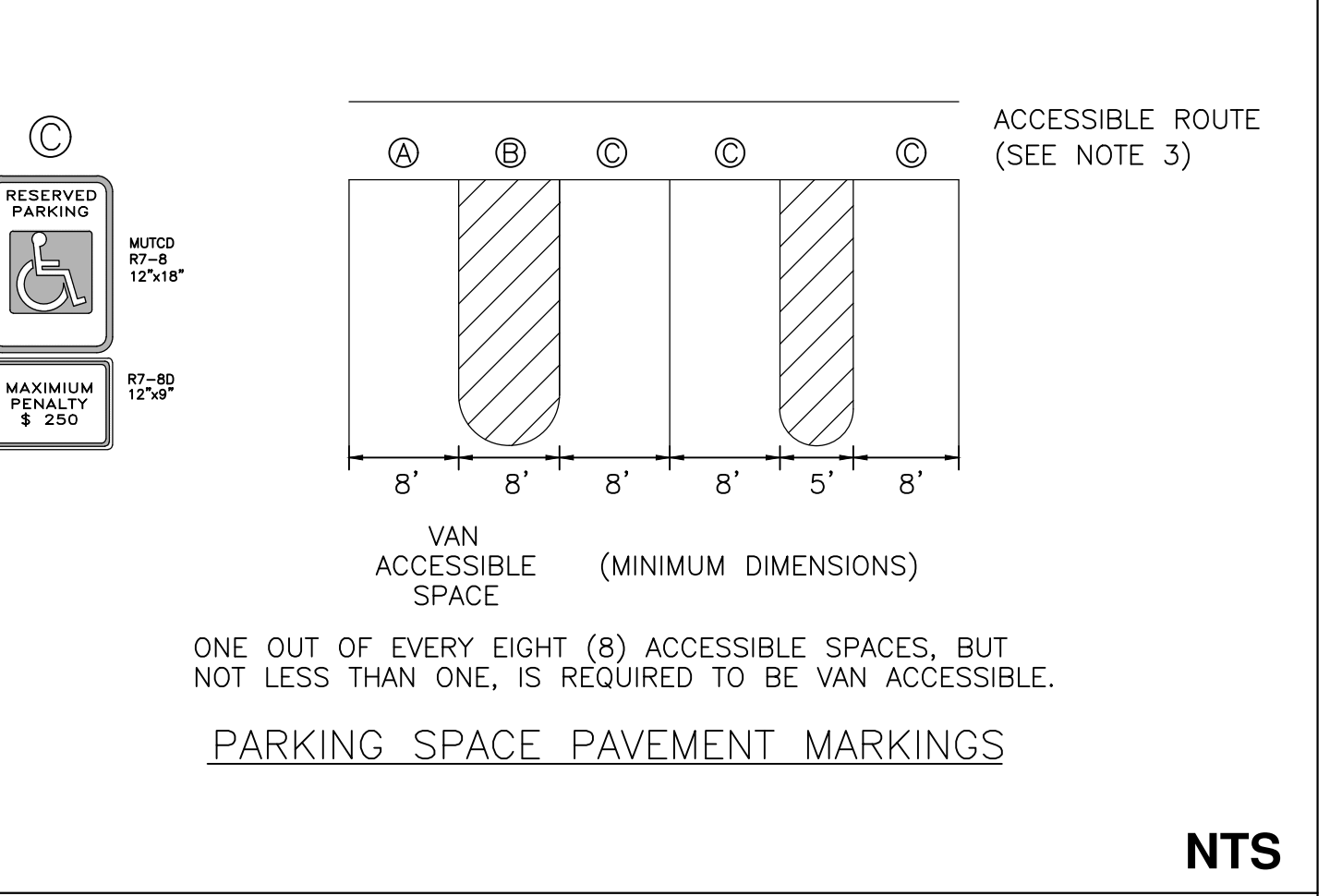

**5 HANDICAP SIGNAGE AND PAVEMENT MARKINGS**

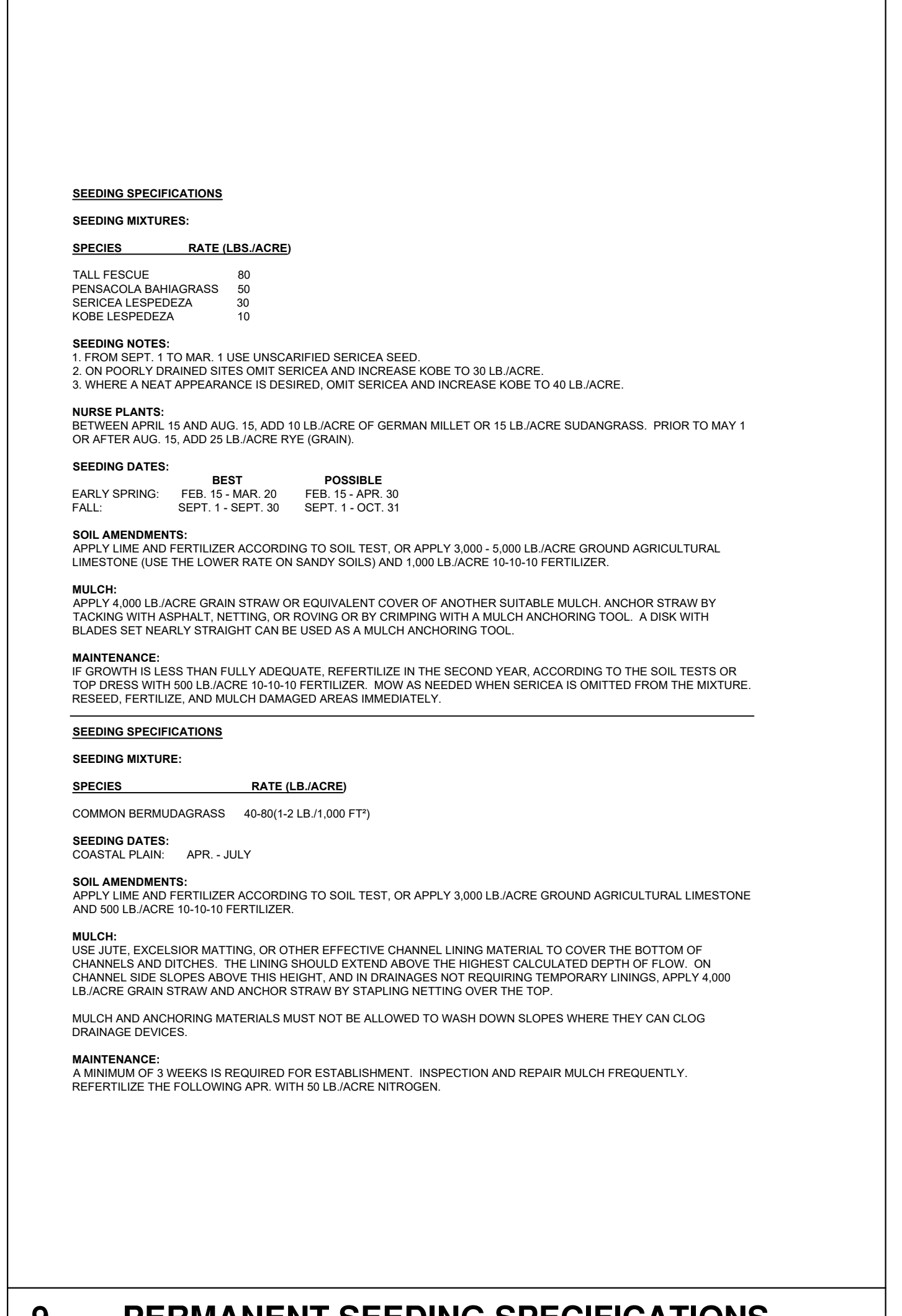

**8 TEMPORARY SEEDING SPECIFICATIONS**

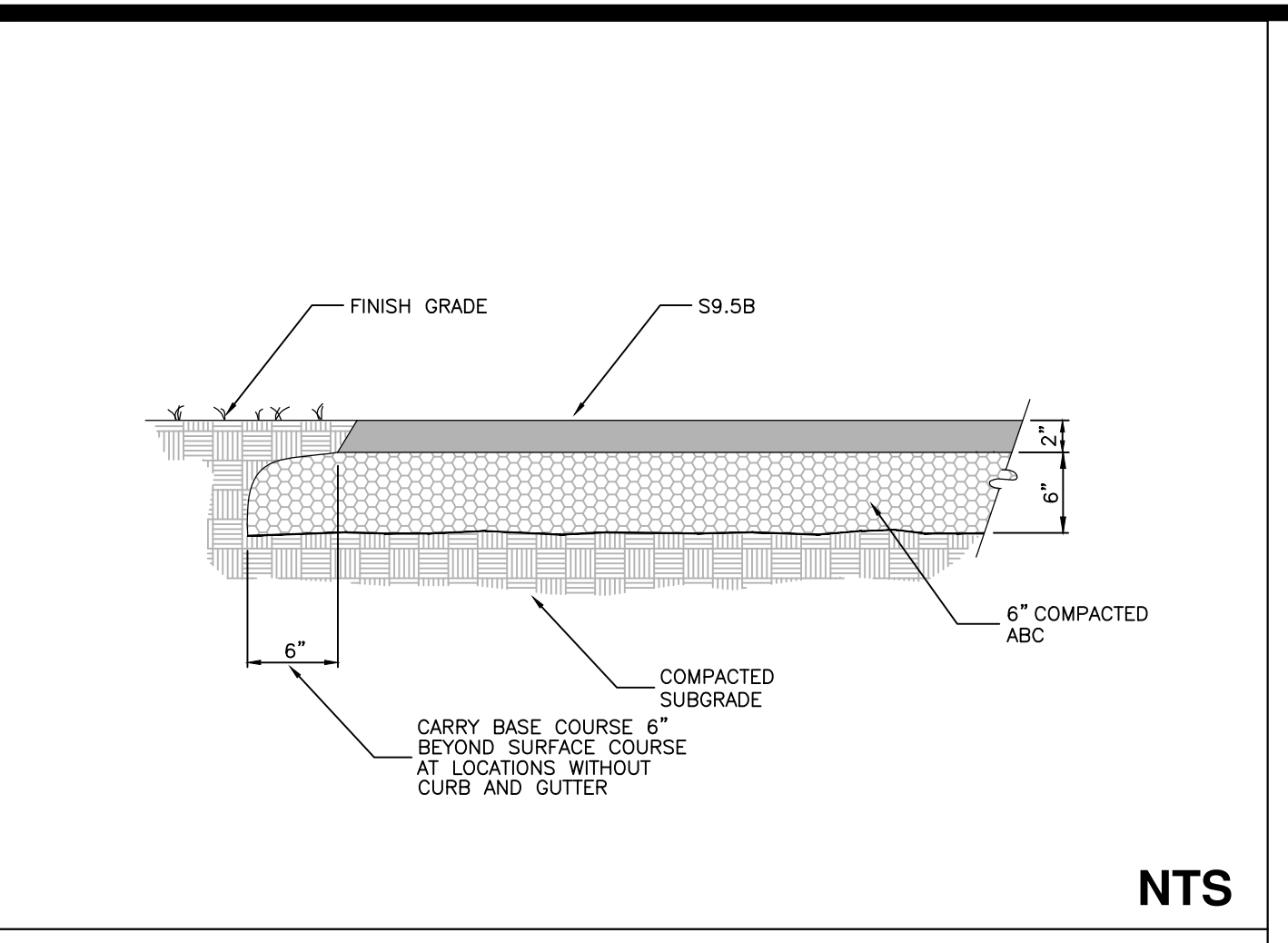

**1 ASPHALT PAVEMENT**

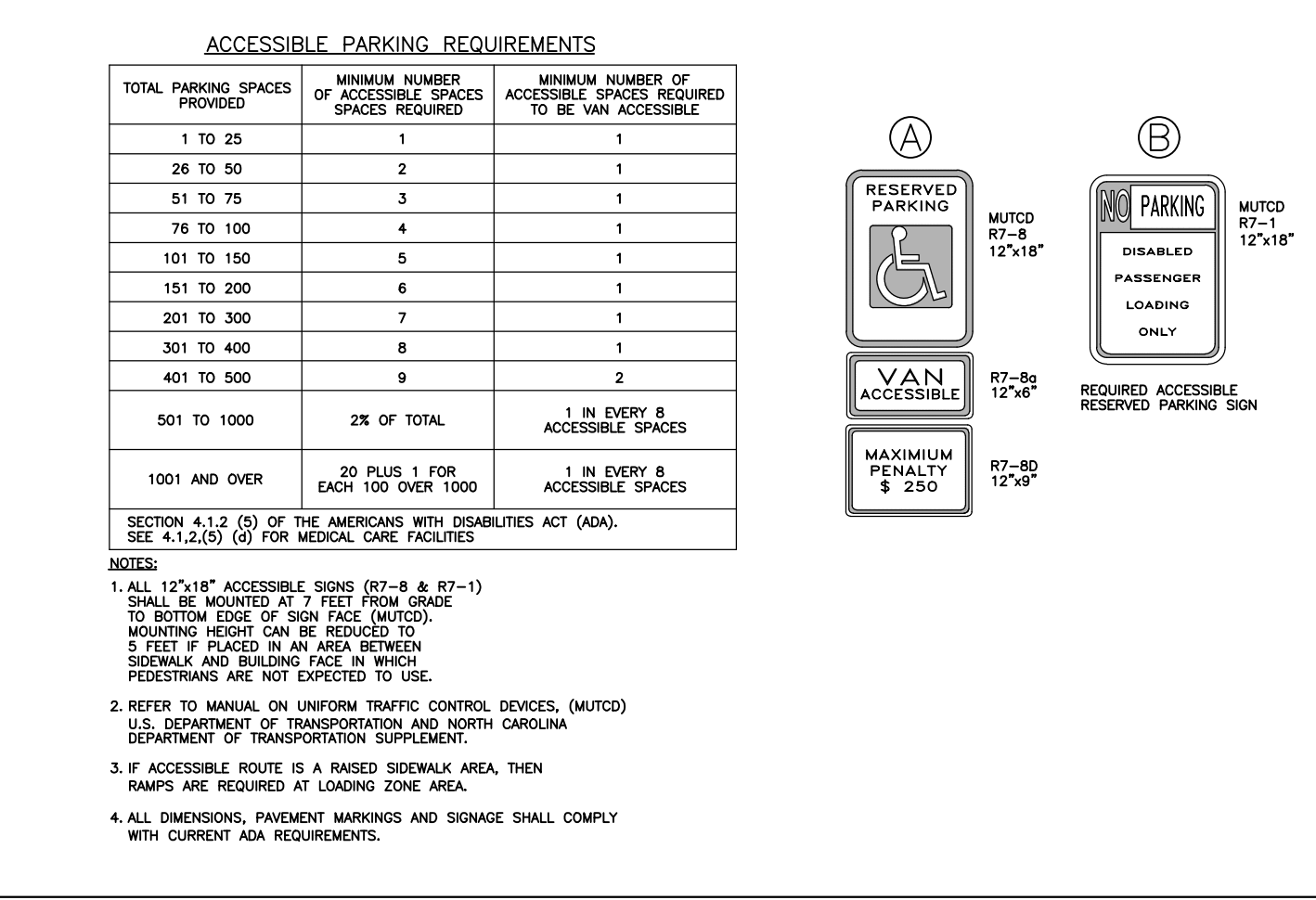

**3 CONCRETE WHEEL STOP**

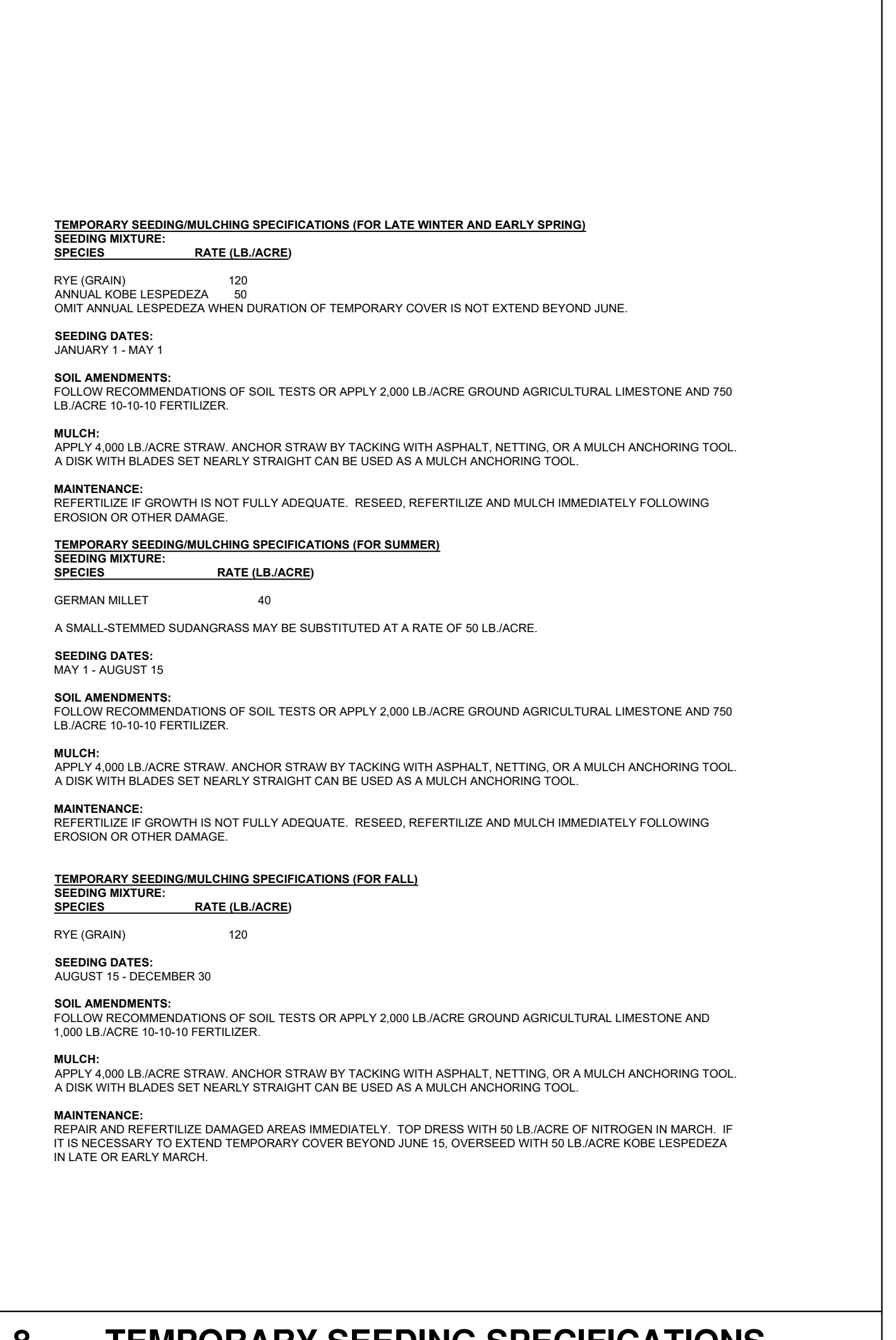

**8 TEMPORARY SEEDING SPECIFICATIONS**



REVISIONS

PROJECT NAME

**AIRPORT ROAD HANGAR**

WATER DETAILS

CLIENT

**BRIAN RAYNOR**

2031 Middle Road  
 Fayetteville, NC 28312  
 Phone: (910) 824-1238  
 Fax: (910) 678-9988

PROJECT INFORMATION

DESIGNED BY:	SCOTT
DRAWN BY:	SCOTT
CHECKED BY:	CHRIS
PROJECT NUMBER:	1942

DRAWING SCALE

NOT TO SCALE

DATE RELEASED

OCTOBER 16, 2023

SHEET NUMBER

**C-5.1**

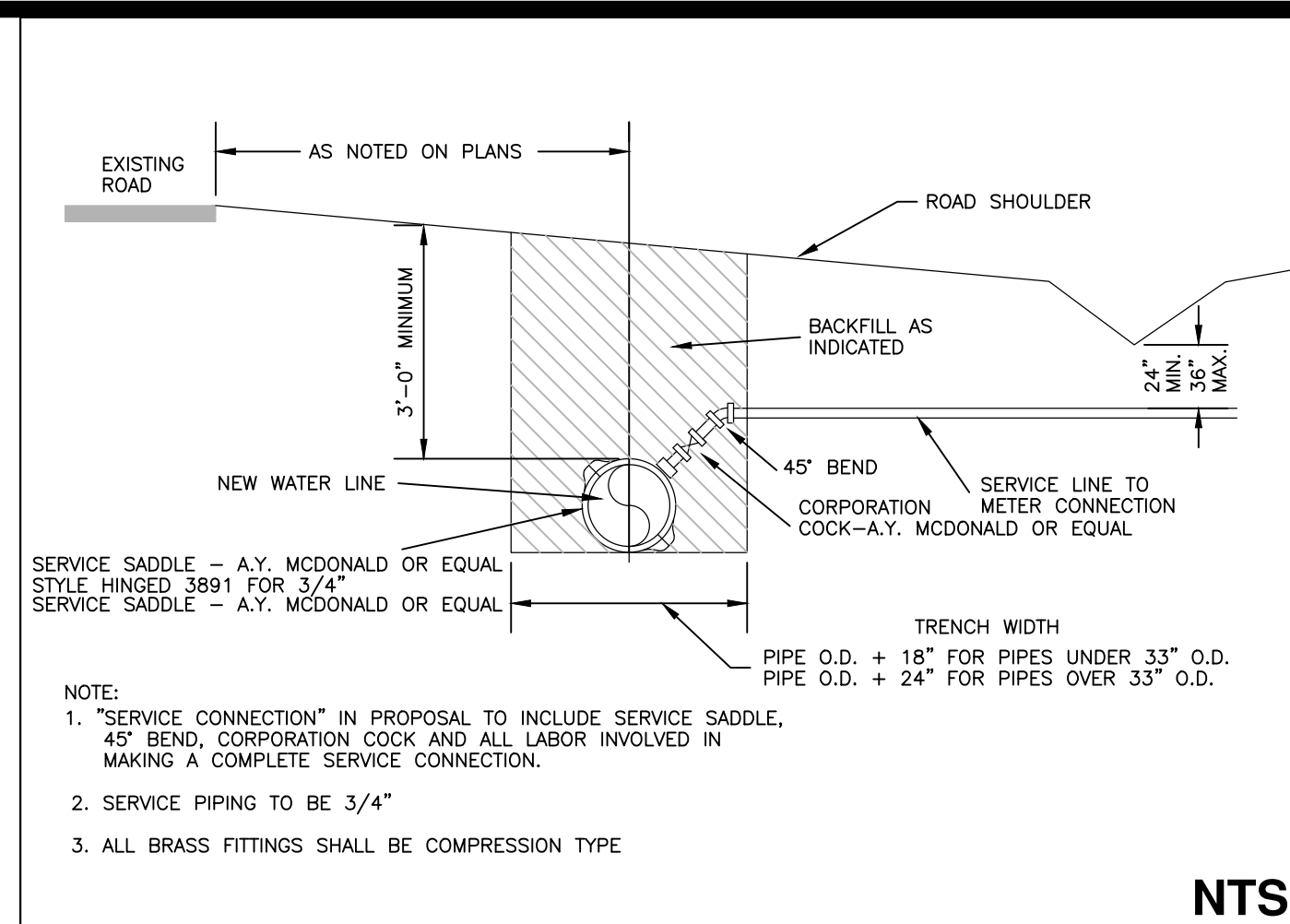

**3 TYPICAL WATER SERVICE CONNECTION**

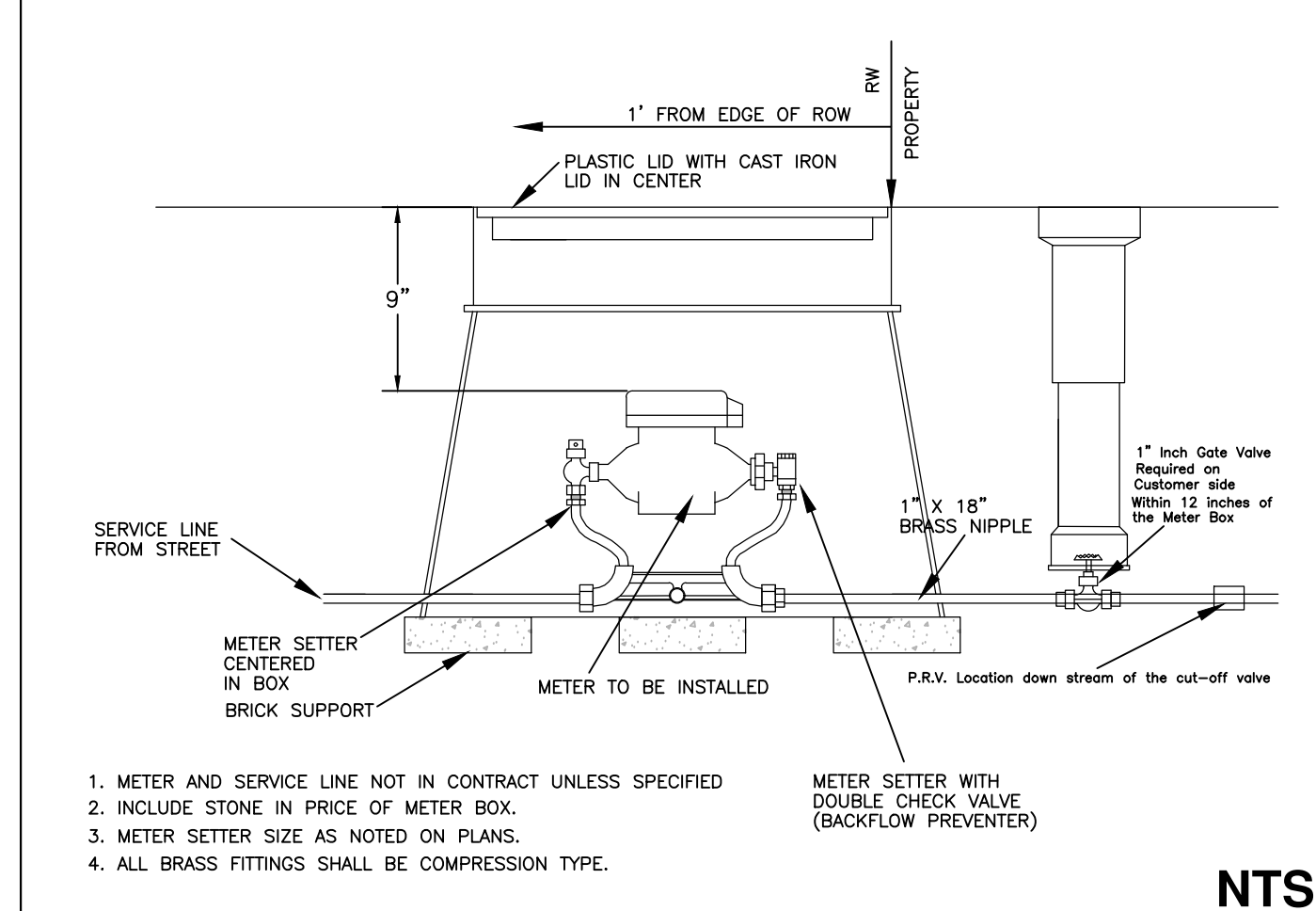

**5 TYPICAL 1" METER BOX INSTALLATION**

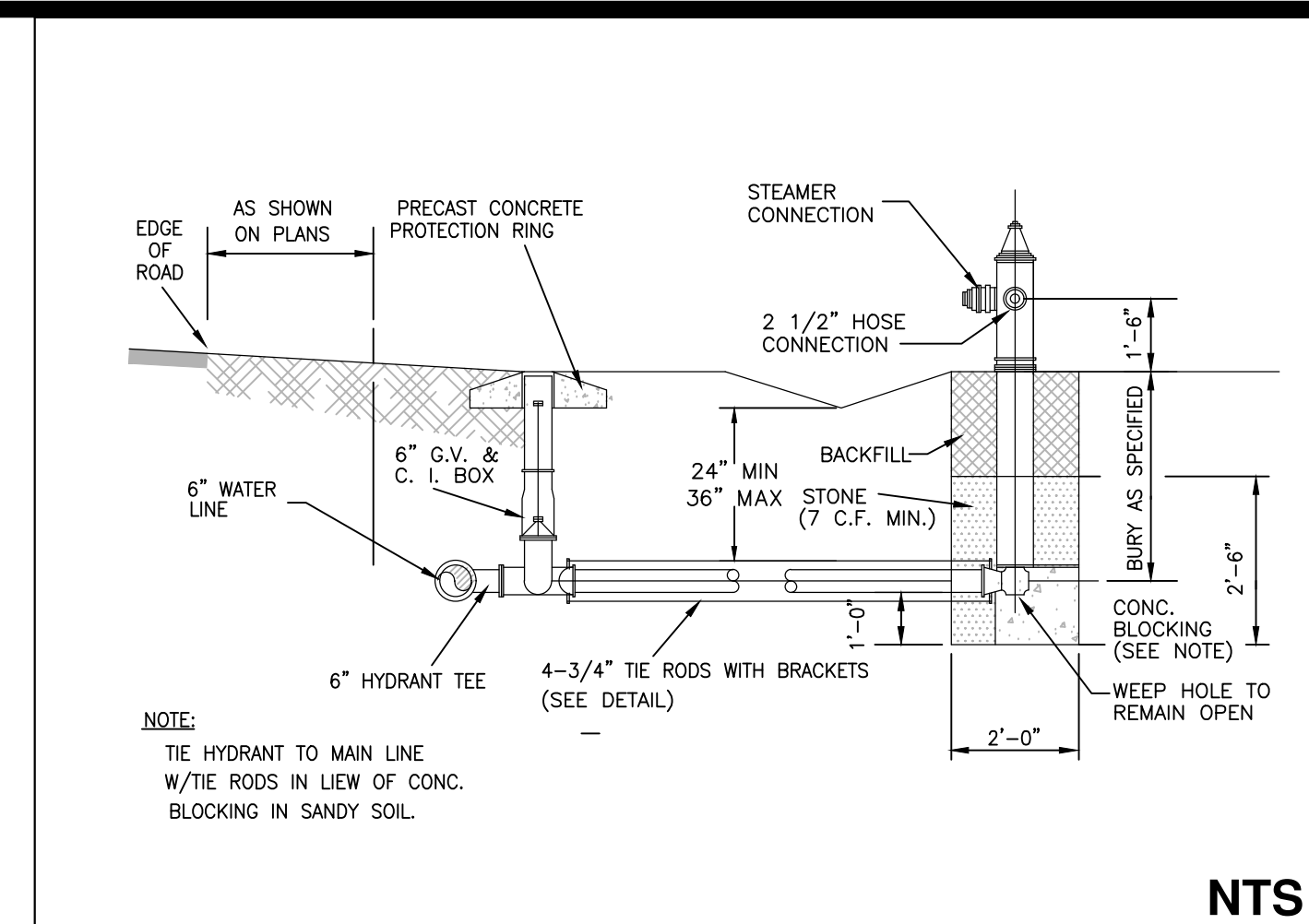

**4 FIRE HYDRANT ASSEMBLY INSTALLATION**

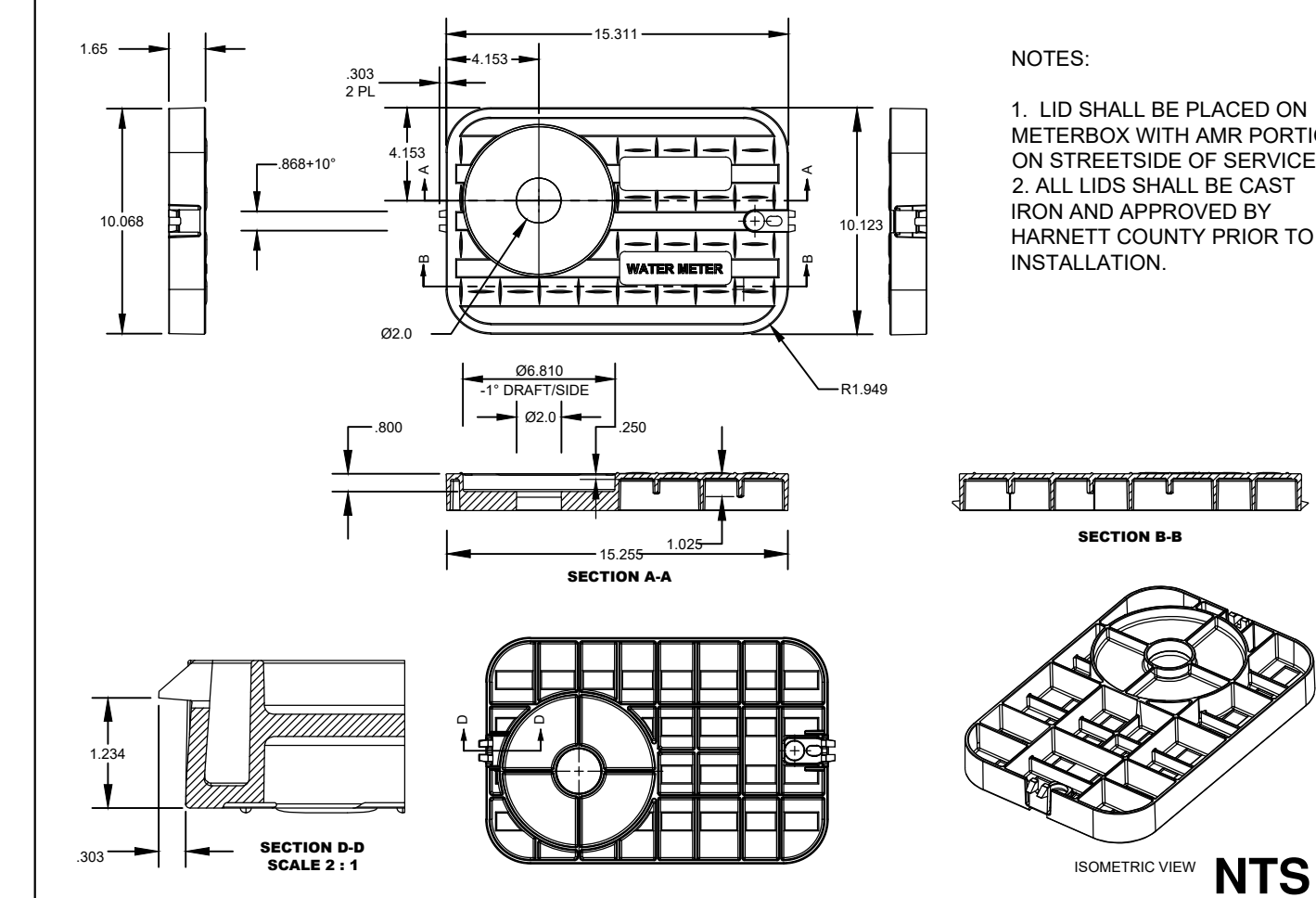

**6 METER BOX AMR LID**

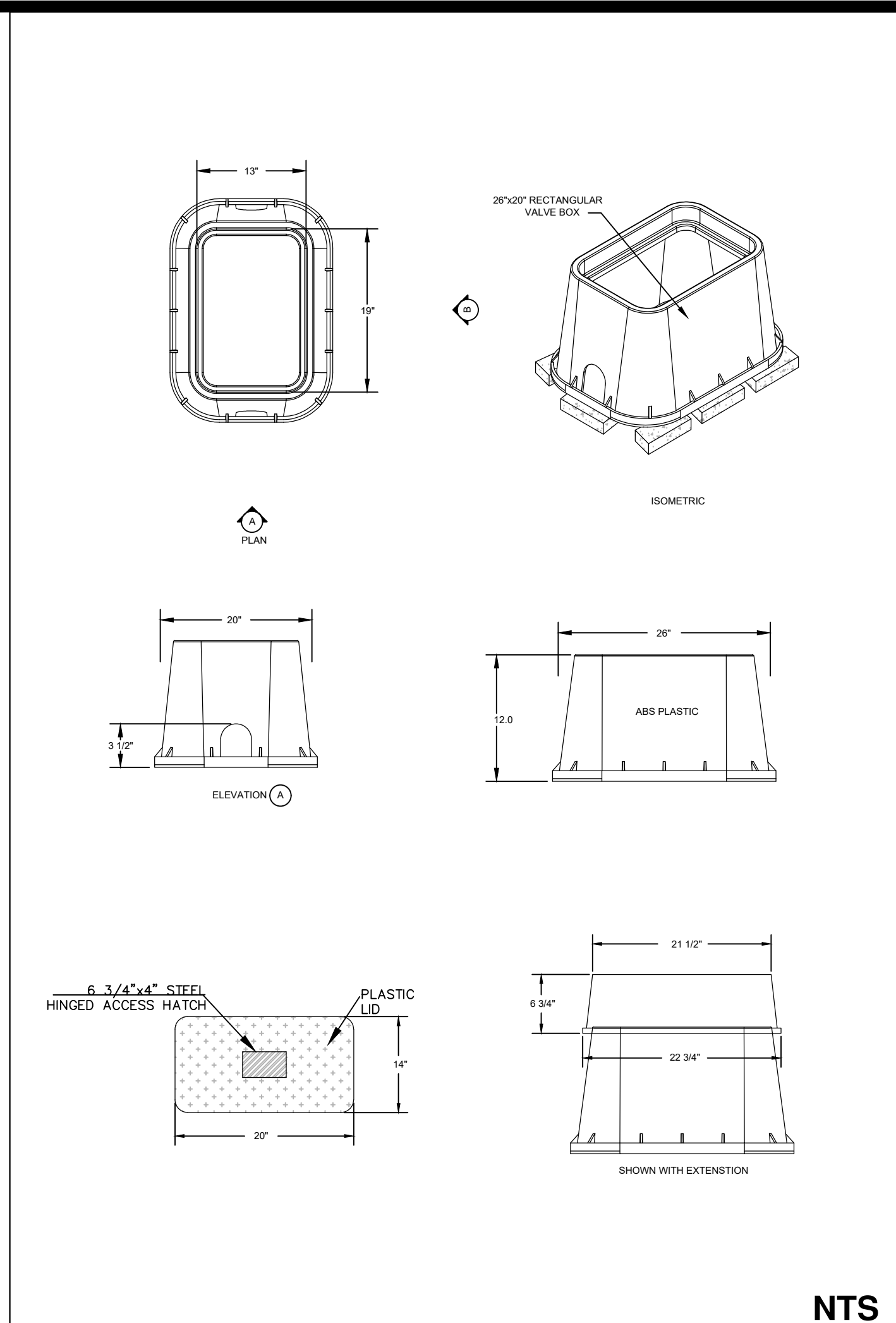

**1 METER BOX DETAIL FOR 1" SERVICE**

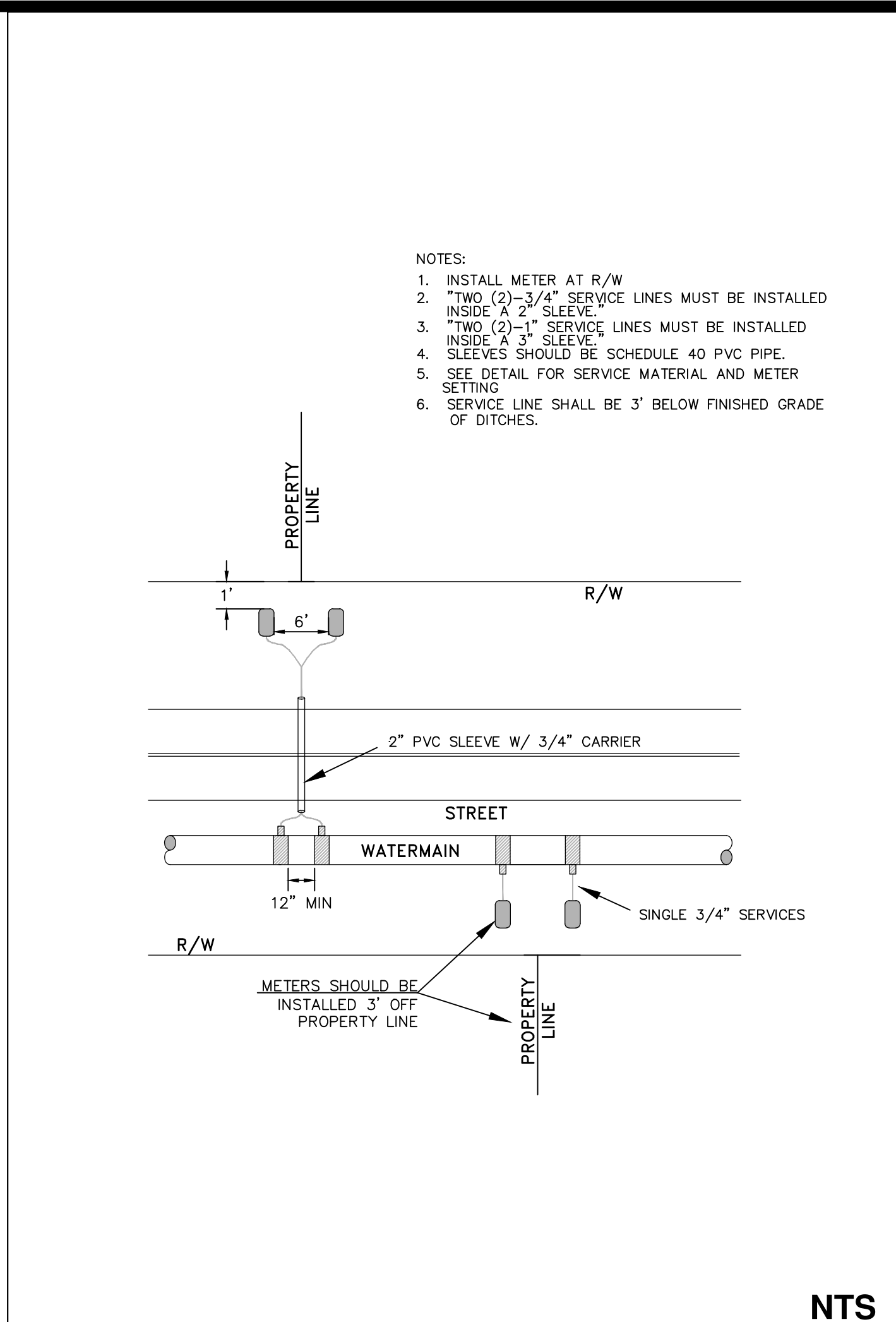

**2 TYP. DOMESTIC WATER SERVICE DETAIL**

I:\Brian Raynor\1942\Airport Hangar\DWG\3D\20231016\C-5.1.dwg - C-5.1.dwg - 10/17/2023 8:41:38 AM