

Item # _____
Project : _____
Qty : _____

14" Deep Economy Series Sinks

Model No.

E3CWP1515



Additional Sizes

<i>E3CWP1515</i>	<i>E3CWP1824</i>
<i>E3CWP1515L-15</i>	<i>E3CWP1824L-18</i>
<i>E3CWP1515R-15</i>	<i>E3CWP1824R-18</i>
<i>E3CWP15152-15</i>	<i>E3CWP1824L-24</i>
<i>E3CWP1818</i>	<i>E3CWP1824R-24</i>
<i>E3CWP1818L-18</i>	<i>E3CWP18242-18</i>
<i>E3CWP1818R-18</i>	<i>E3CWP18242-24</i>
<i>E3CWP18182-18</i>	<i>E3CWP2424</i>
<i>E3CWP18182-24</i>	<i>E3CWP24242-24</i>

← **E3CWP18242-18**

Features:

- 18 Gauge 304 Series Stainless Steel.

Warranty Info:

- See Last Pages



Revised

04/26/2024

E3CWP1515

<i>E3CWP1515</i>	<i>E3CWP1818</i>	<i>E3CWP18182-24</i>	<i>E3CWP1824L-24</i>	<i>E3CWP2424</i>
<i>E3CWP1515L-15</i>	<i>E3CWP1818L-18</i>	<i>E3CWP1824</i>	<i>E3CWP1824R-24</i>	<i>E3CWP24242-24</i>
<i>E3CWP1515R-15</i>	<i>E3CWP1818R-18</i>	<i>E3CWP1824L-18</i>	<i>E3CWP18242-18</i>	
<i>E3CWP15152-15</i>	<i>E3CWP18182-18</i>	<i>E3CWP1824R-18</i>	<i>E3CWP18242-24</i>	

SERV-WARE™

www.servware.com

Phone:(800).768.5953

Fax:(800).976.1299

Socket View

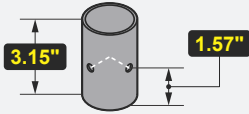

Top View

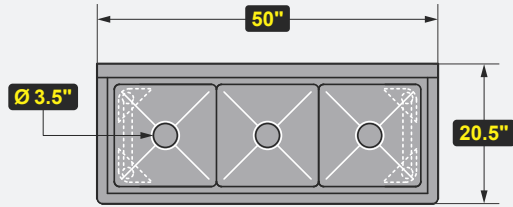

Side View

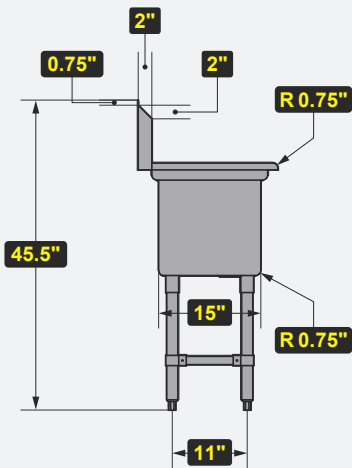

Front View

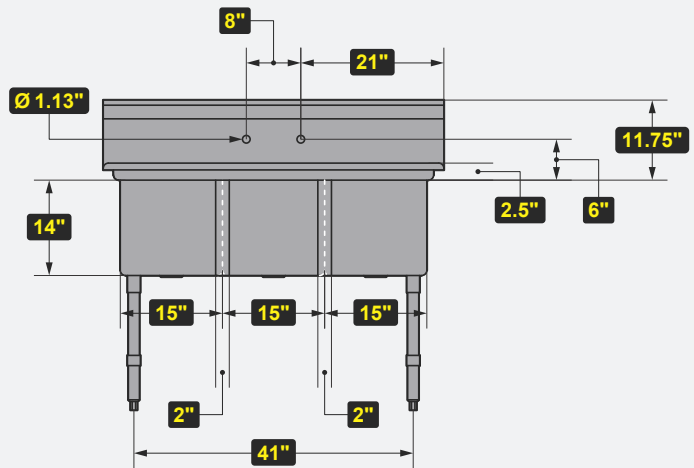

MODEL #	DESCRIPTION	DIMENSIONS (W x D x H)	WEIGHT/LBS. (Shipping)
E3CWP1515	14" Economy Sink	50" W x 20.5" D x 45.5" H	133 lbs.

# OF BOWLS	BOWL DIMENSIONS (W x D x H)	BACK SPLASH
3	15" W x 15" D x 14" H	N/A

DRAIN BOARDS
NO
N/A

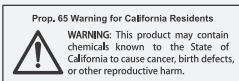

Phone:(800).768.5953
 Fax:(800).976.1299

Top View

Socket View

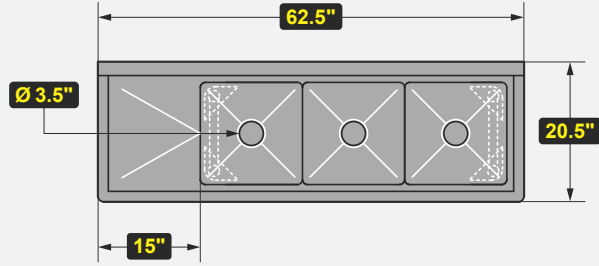
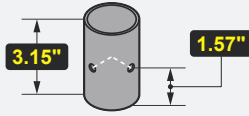

Side View

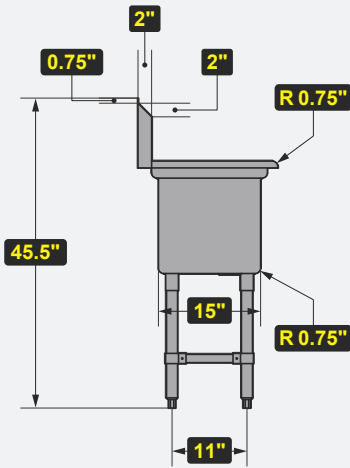

Front View

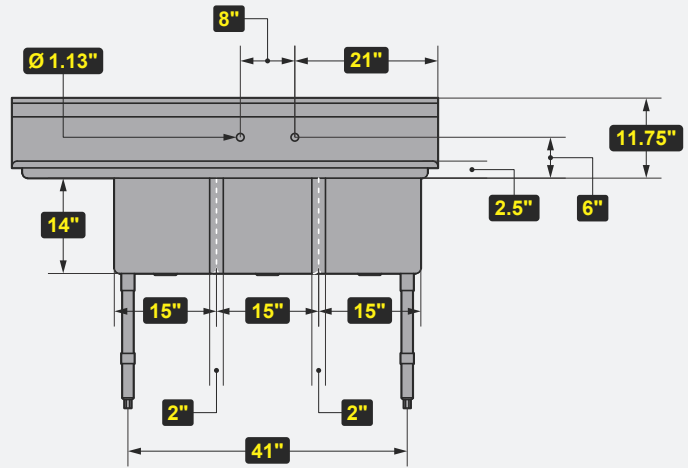

MODEL #	DESCRIPTION	DIMENSIONS (W x D x H)	WEIGHT/LBS. (Shipping)
E3CWP1515L-15	14" Economy Sink	62.5" W x 20.5" D x 45.5" H	158 lbs.

# OF BOWLS	BOWL DIMENSIONS (W x D x H)	BACK SPLASH
3	15" W x 15" D x 14" H	N/A

DRAIN BOARDS

YES

One 15" Left

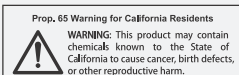

Phone:(800).768.5953
 Fax:(800).976.1299

Socket View

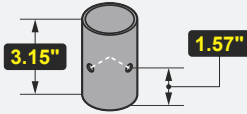

Top View

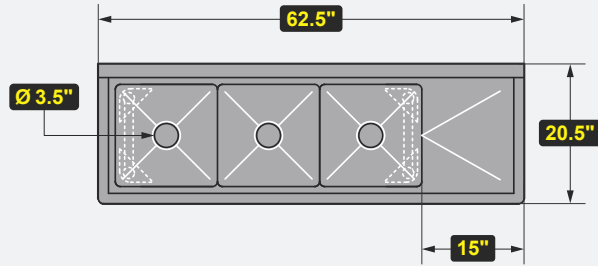

Side View

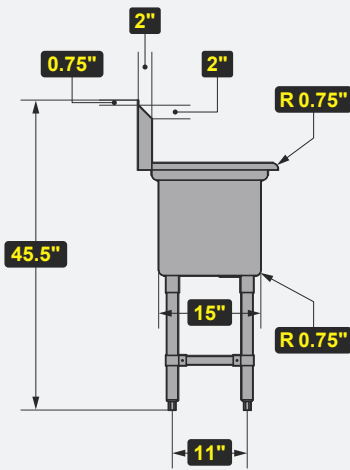

Front View

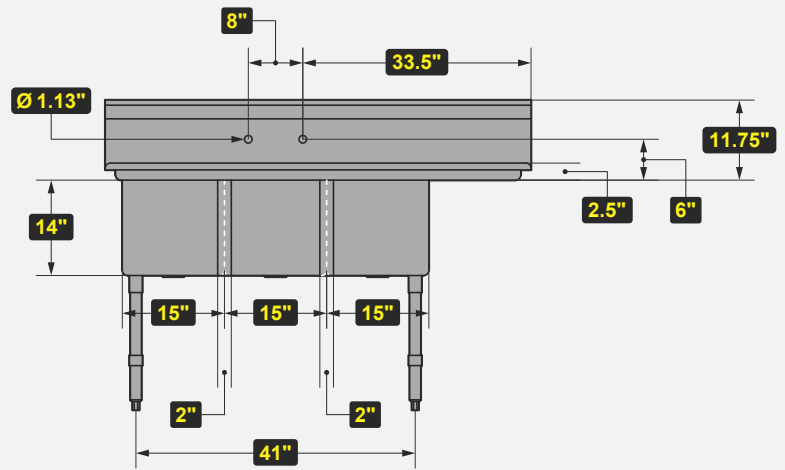

MODEL #	DESCRIPTION	DIMENSIONS (W x D x H)	WEIGHT/LBS. (Shipping)
E3CWP1515R-15	14" Economy Sink	62.5" W x 20.5" D x 45.5" H	158 lbs.

# OF BOWLS	BOWL DIMENSIONS (W x D x H)	BACK SPLASH
3	15" W x 15" D x 14" H	N/A

DRAIN BOARDS

YES

One 15" Right

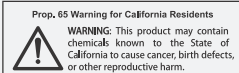

Phone:(800).768.5953
 Fax:(800).976.1299

Socket View

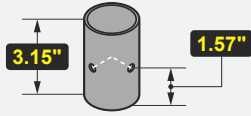

Top View

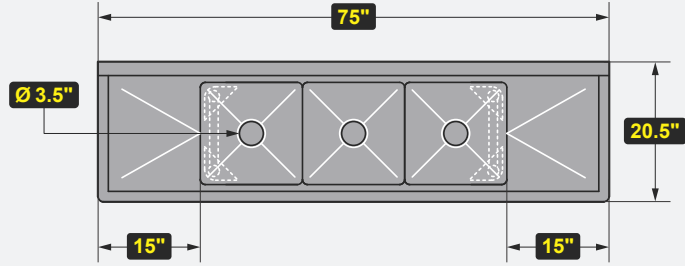

Side View

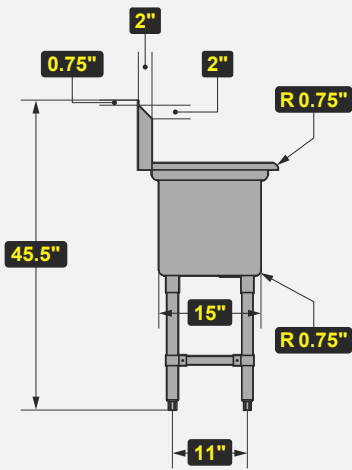

Front View

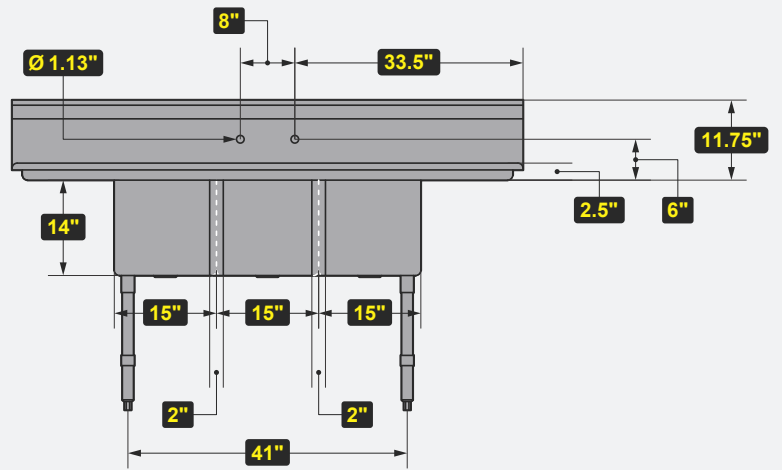

MODEL #	DESCRIPTION	DIMENSIONS (W x D x H)	WEIGHT/LBS. (Shipping)
E3CWP15152-15	14" Economy Sink	75" W x 20.5" D x 45.5" H	175 lbs.

# OF BOWLS	BOWL DIMENSIONS (W x D x H)	BACK SPLASH
3	15" W x 15" D x 14" H	N/A

DRAIN BOARDS

YES

Two 15"

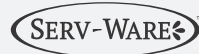
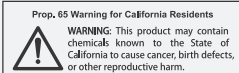

Phone:(800).768.5953
 Fax:(800).976.1299

Socket View

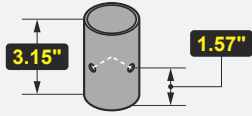

Top View

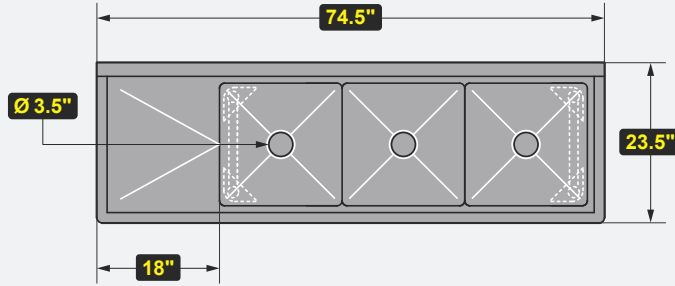

Side View

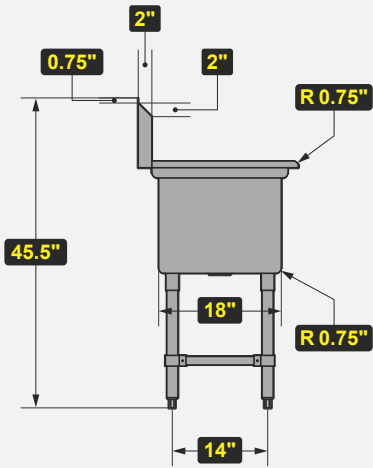

Front View

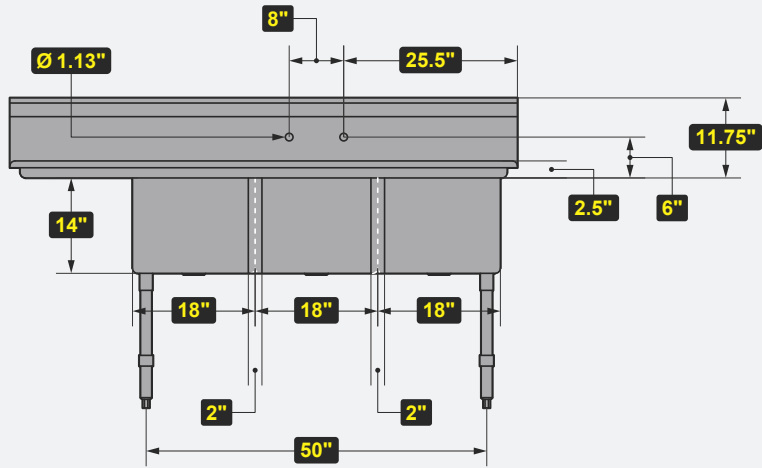

MODEL #	DESCRIPTION	DIMENSIONS (W x D x H)	WEIGHT/LBS. (Shipping)
E3CWP1818L-18	14" Economy Sink	74.5" W x 23.5" D x 45.5" H	110 lbs.

# OF BOWLS	BOWL DIMENSIONS (W x D x H)	BACK SPLASH
3	18" W x 18" D x 14" H	N/A

DRAIN BOARDS

YES

One 18" Left

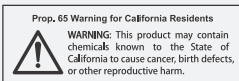

Phone:(800).768.5953
 Fax:(800).976.1299

Socket View

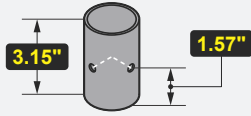

Top View

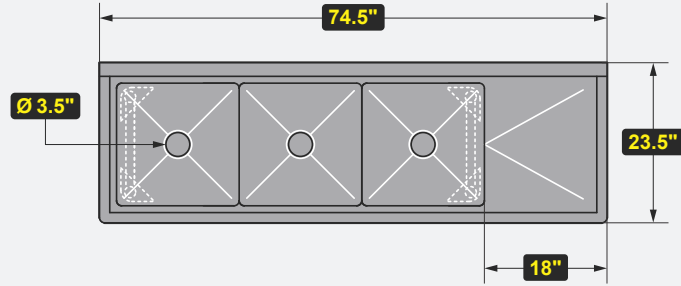

Side View

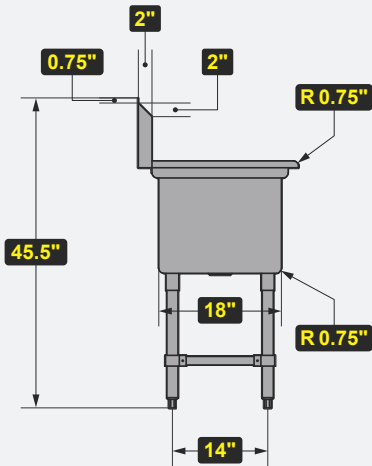

Front View

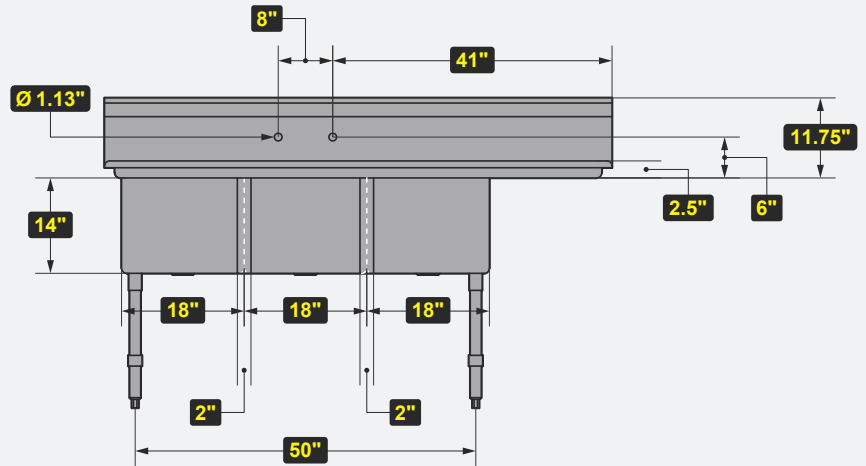

MODEL #	DESCRIPTION	DIMENSIONS (W x D x H)	WEIGHT/LBS. (Shipping)
E3CWP1818R-18	14" Economy Sink	74.5" W x 23.5" D x 45.5" H	110 lbs.

# OF BOWLS	BOWL DIMENSIONS (W x D x H)	BACK SPLASH
3	18" W x 18" D x 14" H	N/A

DRAIN BOARDS

YES

One 18" Right

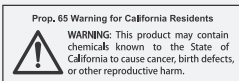

Phone:(800).768.5953
 Fax:(800).976.1299

Socket View

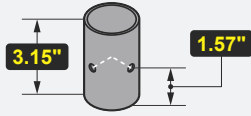

Top View

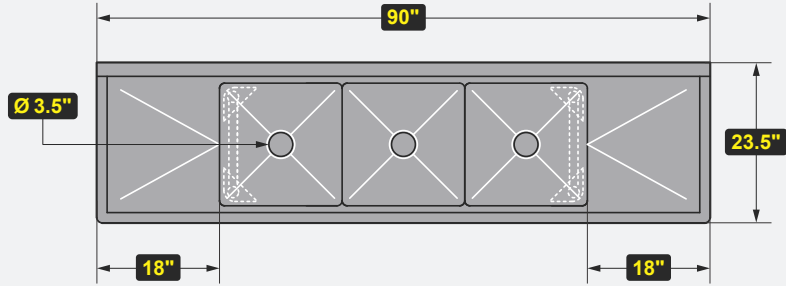

Side View

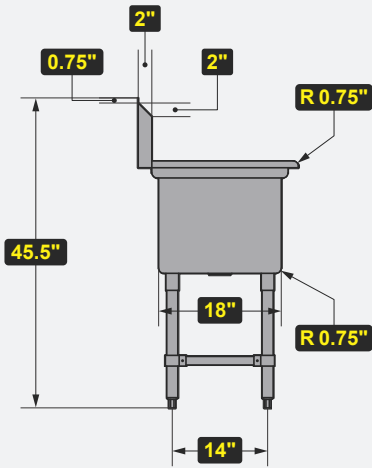

Front View

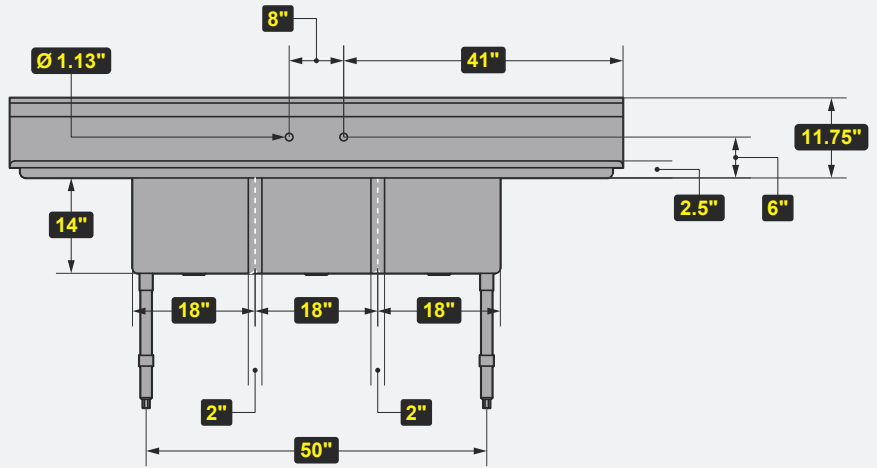

MODEL #	DESCRIPTION	DIMENSIONS (W x D x H)	WEIGHT/LBS. (Shipping)
E3CWP18182-18	14" Economy Sink	90" W x 23.5" D x 45.5" H	126 lbs.

# OF BOWLS	BOWL DIMENSIONS (W x D x H)	BACK SPLASH
3	18" W x 18" D x 14" H	N/A

DRAIN BOARDS

YES

Two 18"

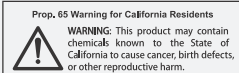

Phone:(800).768.5953
 Fax:(800).976.1299

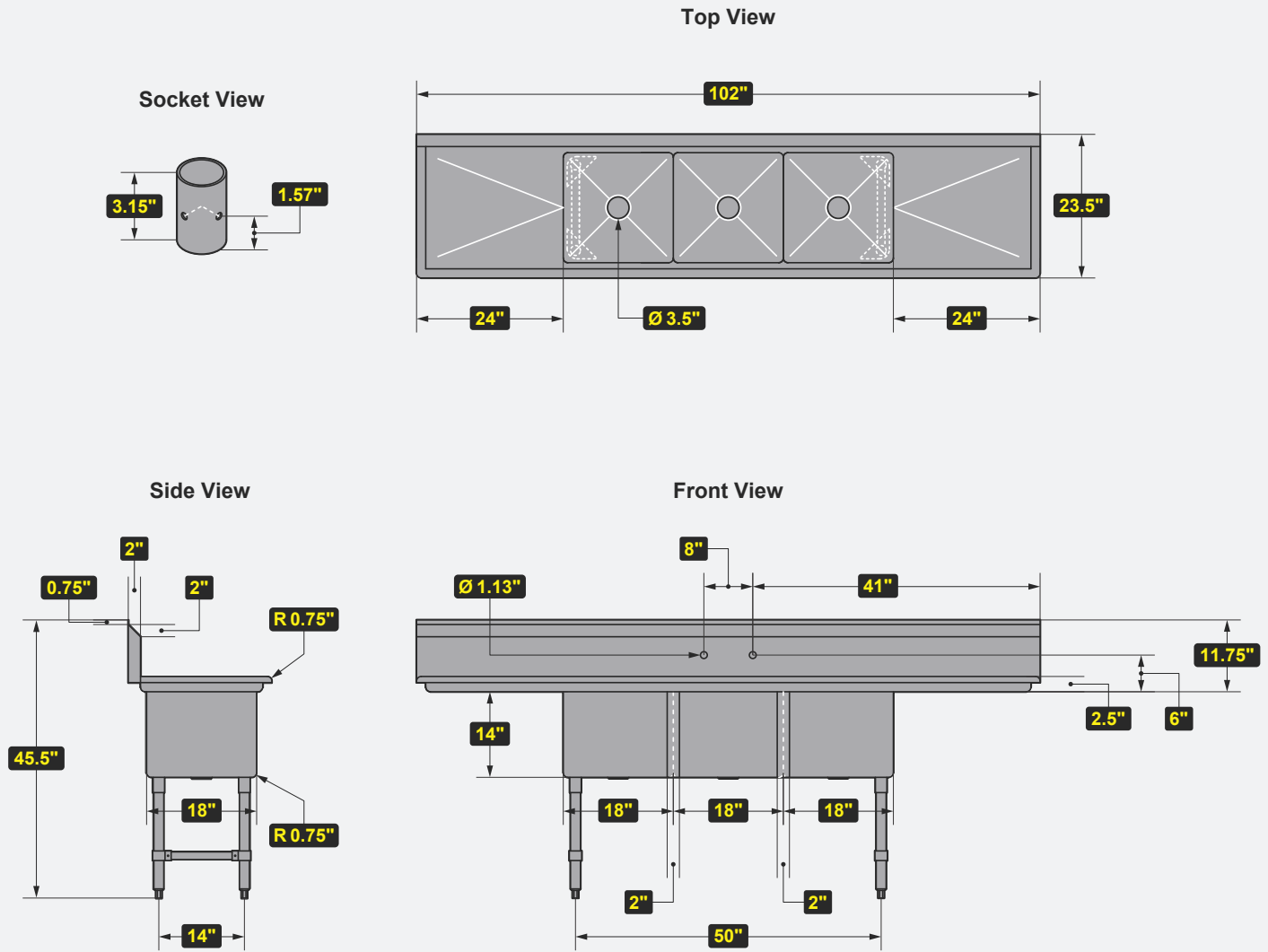

MODEL #	DESCRIPTION	DIMENSIONS (W x D x H)	WEIGHT/LBS. (Shipping)
E3CWP18182-24	14" Economy Sink	102" W x 23.5" D x 45.5" H	167 lbs.

# OF BOWLS	BOWL DIMENSIONS (W x D x H)	BACK SPLASH
3	18" W x 18" D x 14" H	N/A

DRAIN BOARDS

YES

Two 24"



Prop. 65 Warning for California Residents
 WARNING: This product may contain chemicals known to the State of California to cause cancer, birth defects, or other reproductive harm.

Socket View

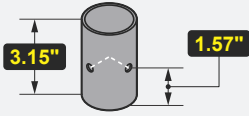

Top View

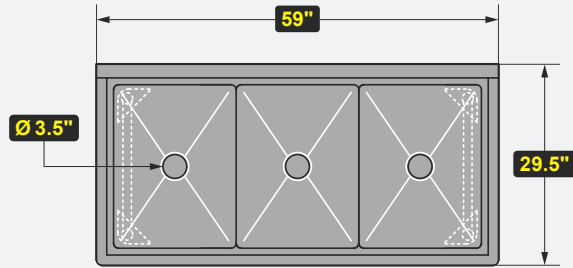

Side View

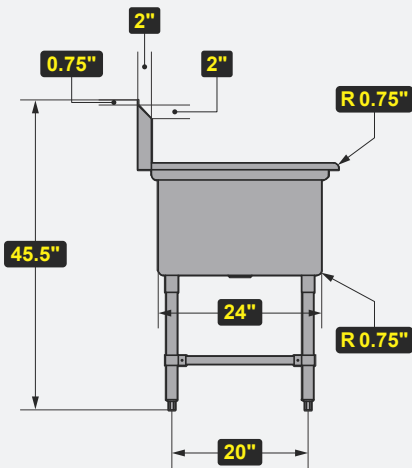

Front View

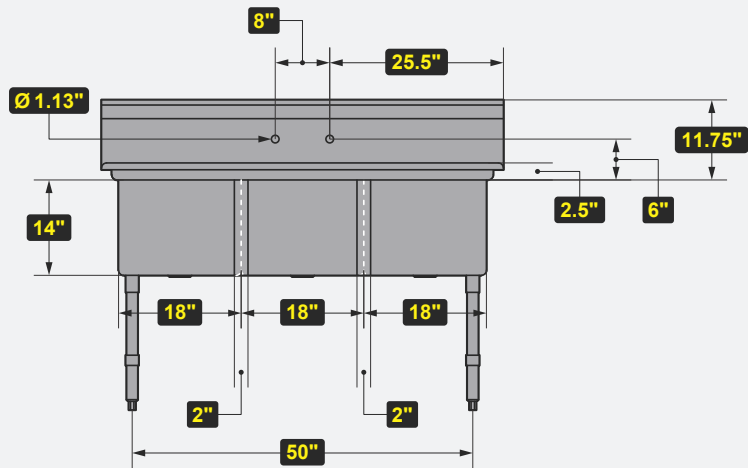

MODEL #	DESCRIPTION	DIMENSIONS (W x D x H)	WEIGHT/LBS. (Shipping)
E3CWP1824	14" Economy Sink	59" W x 29.5" D x 45.5" H	178 lbs.

# OF BOWLS	BOWL DIMENSIONS (W x D x H)	BACK SPLASH
3	18" W x 24" D x 14" H	N/A

DRAIN BOARDS
NO
N/A

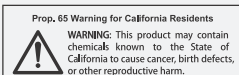

Phone:(800).768.5953
 Fax:(800).976.1299

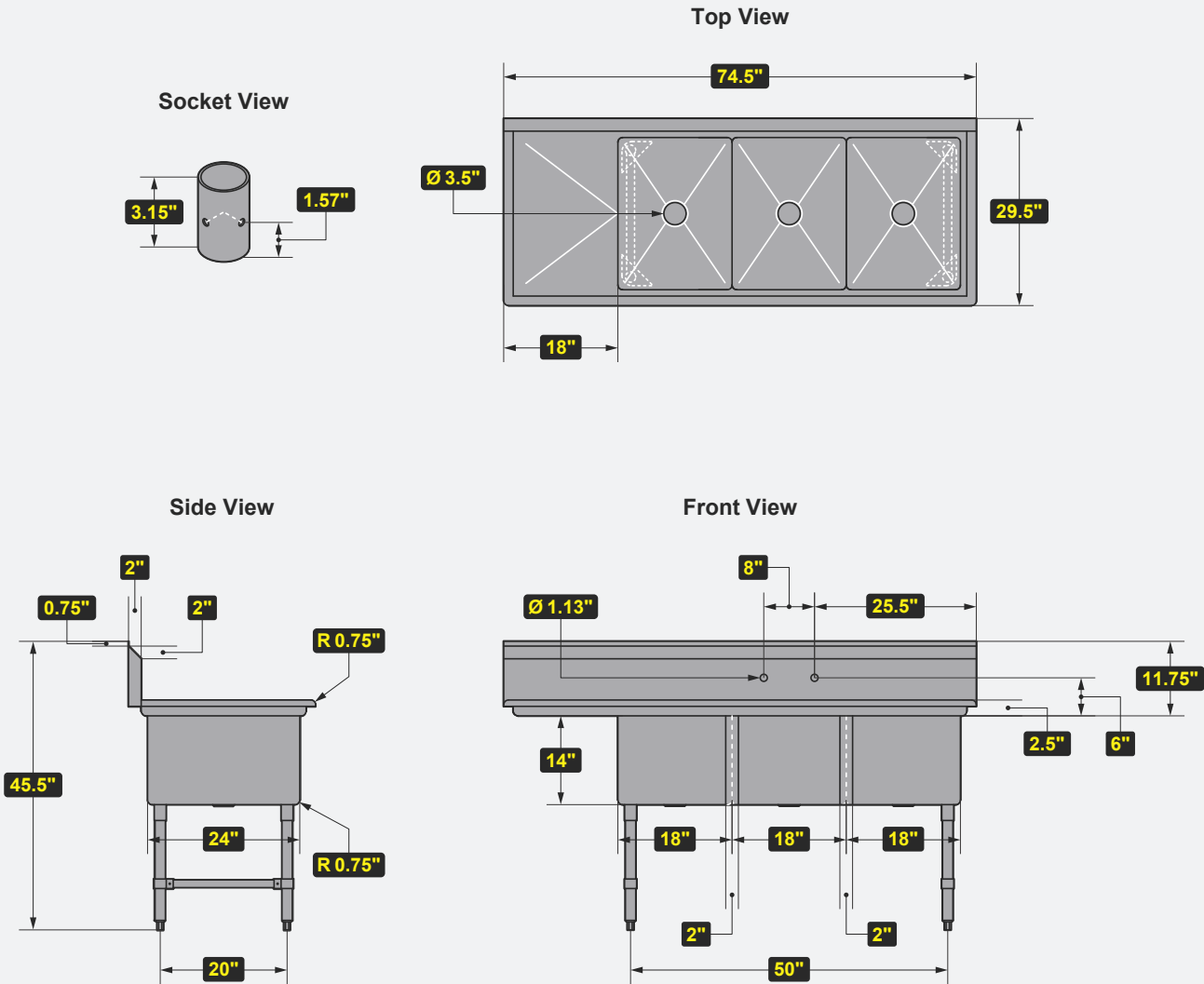

MODEL #	DESCRIPTION	DIMENSIONS (W x D x H)	WEIGHT/LBS. (Shipping)
E3CWP1824L-18	14" Economy Sink	74.5" W x 29.5" D x 45.5" H	112 lbs.

# OF BOWLS	BOWL DIMENSIONS (W x D x H)	BACK SPLASH
3	18" W x 24" D x 14" H	N/A

DRAIN BOARDS

YES

One 18" Left



Prop. 65 Warning for California Residents
 WARNING: This product may contain chemicals known to the State of California to cause cancer, birth defects, or other reproductive harm.



Phone: (800) 768.5953
 Fax: (800) 976.1299

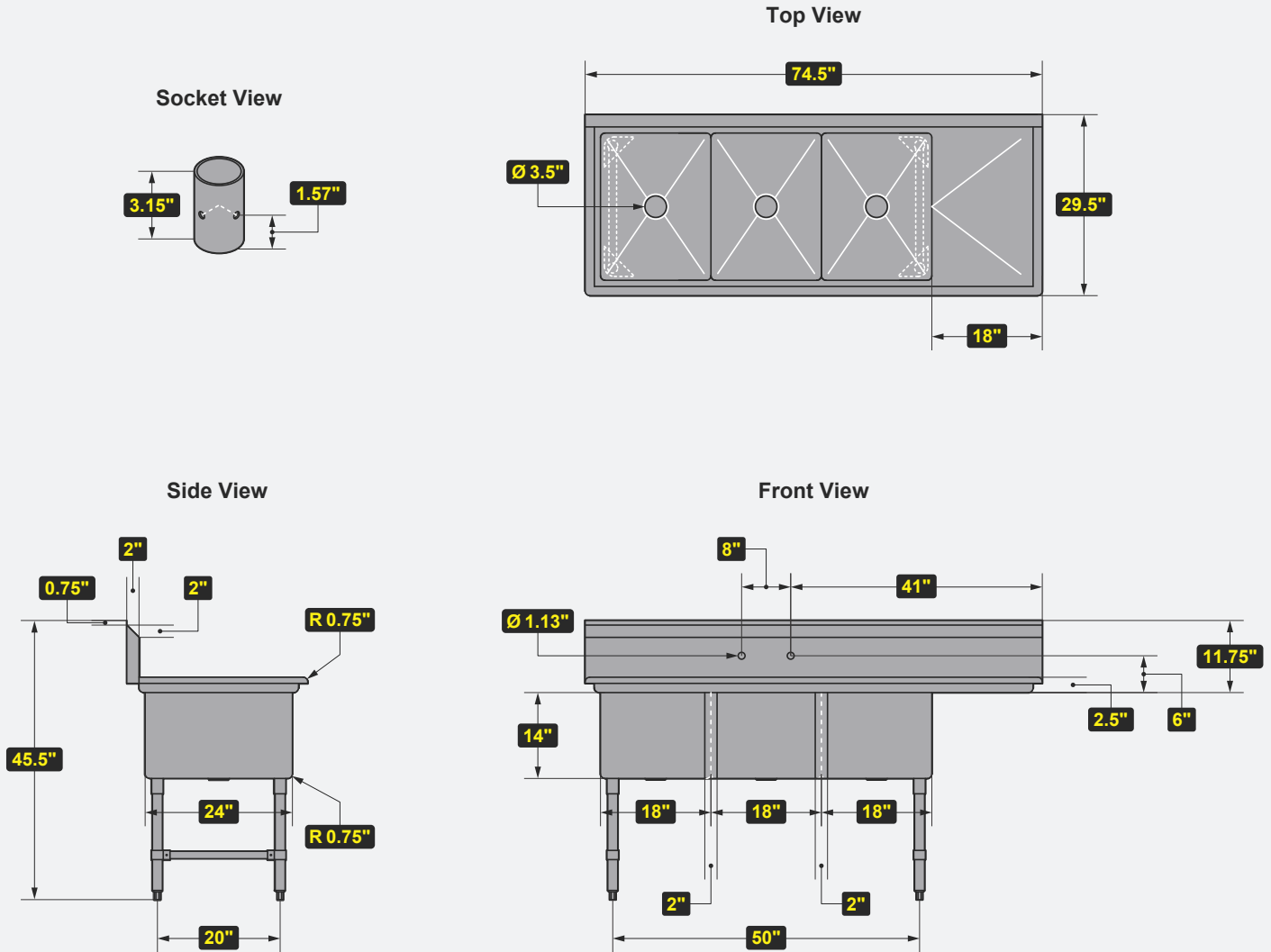

MODEL #	DESCRIPTION	DIMENSIONS	WEIGHT/LBS.
		(W x D x H)	(Shipping)
E3CWP1824R-18	14" Economy Sink	74.5" W x 29.5" D x 45.5" H	112 lbs.

# OF BOWLS	BOWL DIMENSIONS	BACK SPLASH
	(W x D x H)	
3	18" W x 24" D x 14" H	N/A

DRAIN BOARDS

YES

One 18" Right



Prop. 65 Warning for California Residents
 WARNING: This product may contain chemicals known to the State of California to cause cancer, birth defects, or other reproductive harm.



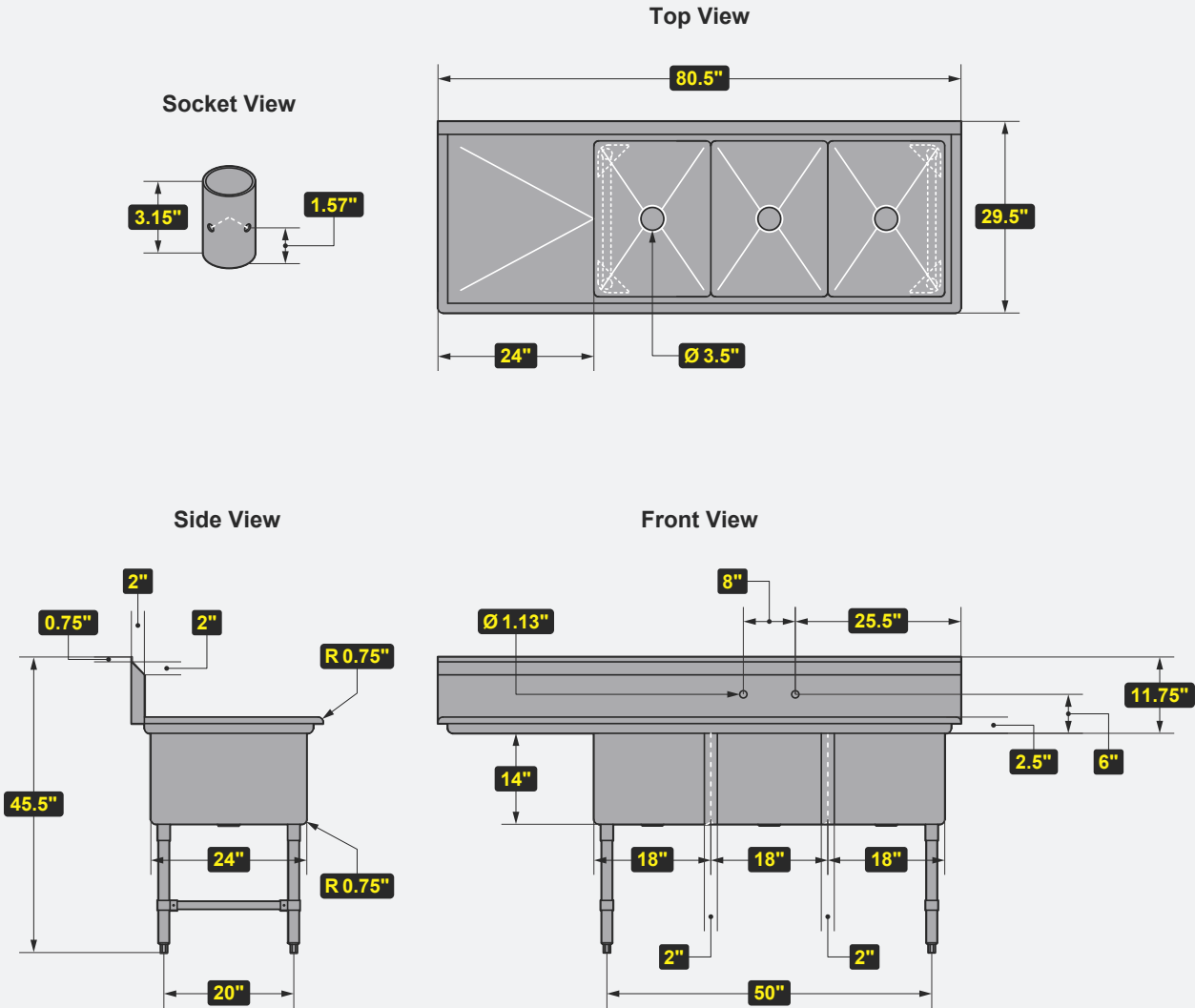

MODEL #	DESCRIPTION	DIMENSIONS (W x D x H)	WEIGHT/LBS. (Shipping)
E3CWP1824L-24	14" Economy Sink	80.5" W x 29.5" D x 45.5" H	120 lbs.

# OF BOWLS	BOWL DIMENSIONS (W x D x H)	BACK SPLASH
3	18" W x 24" D x 14" H	N/A

DRAIN BOARDS

YES

One 24" Left



Prop. 65 Warning for California Residents
 WARNING: This product may contain chemicals known to the State of California to cause cancer, birth defects, or other reproductive harm.

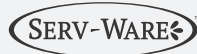

Phone:(800).768.5953
 Fax:(800).976.1299

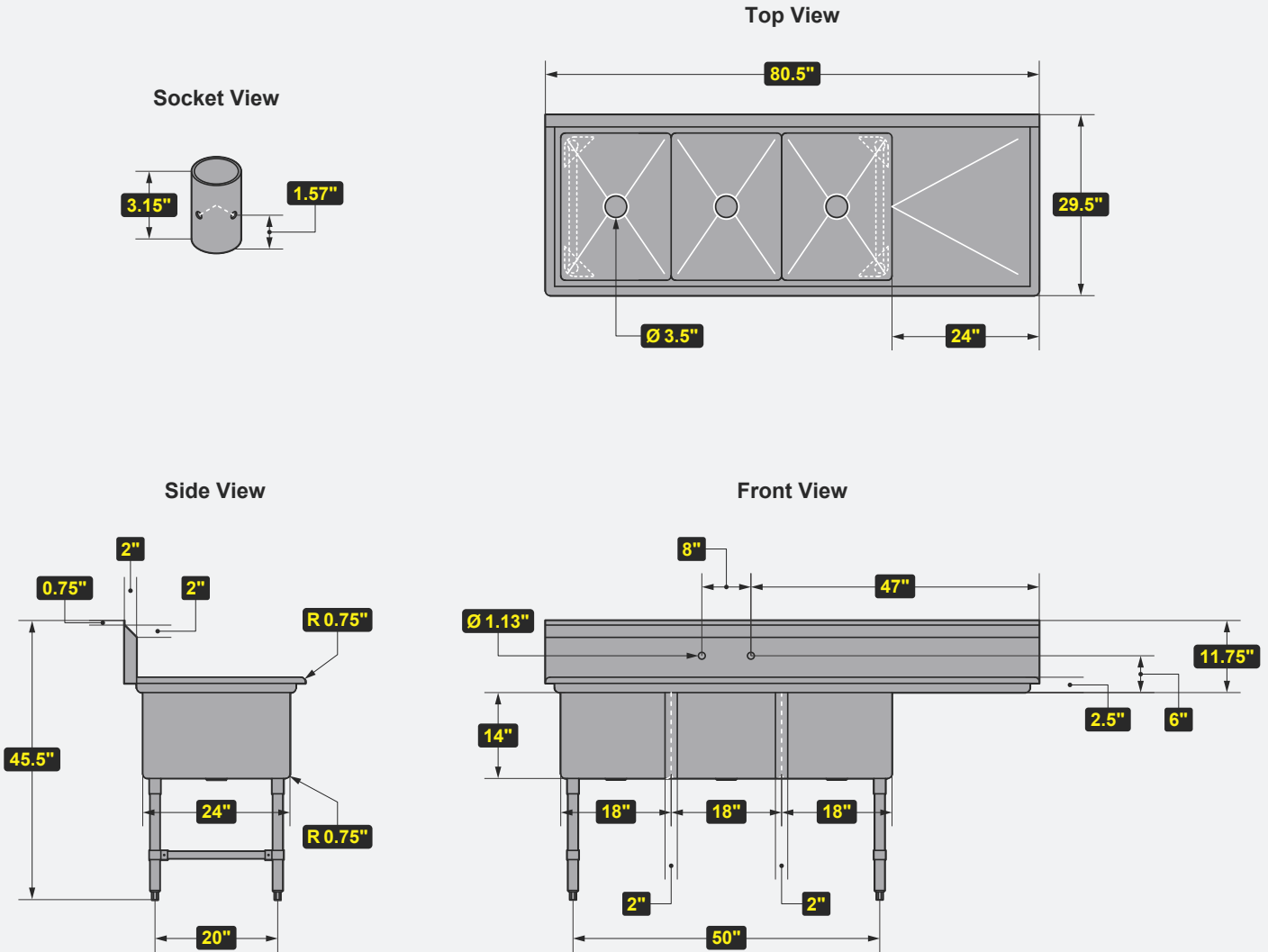

MODEL #	DESCRIPTION	DIMENSIONS (W x D x H)	WEIGHT/LBS. (Shipping)
E3CWP1824R-24	14" Economy Sink	80.5" W x 29.5" D x 45.5" H	120 lbs.

# OF BOWLS	BOWL DIMENSIONS (W x D x H)	BACK SPLASH
3	18" W x 24" D x 14" H	N/A

DRAIN BOARDS

YES

One 24" Right



Prop. 65 Warning for California Residents
 WARNING: This product may contain chemicals known to the State of California to cause cancer, birth defects, or other reproductive harm.

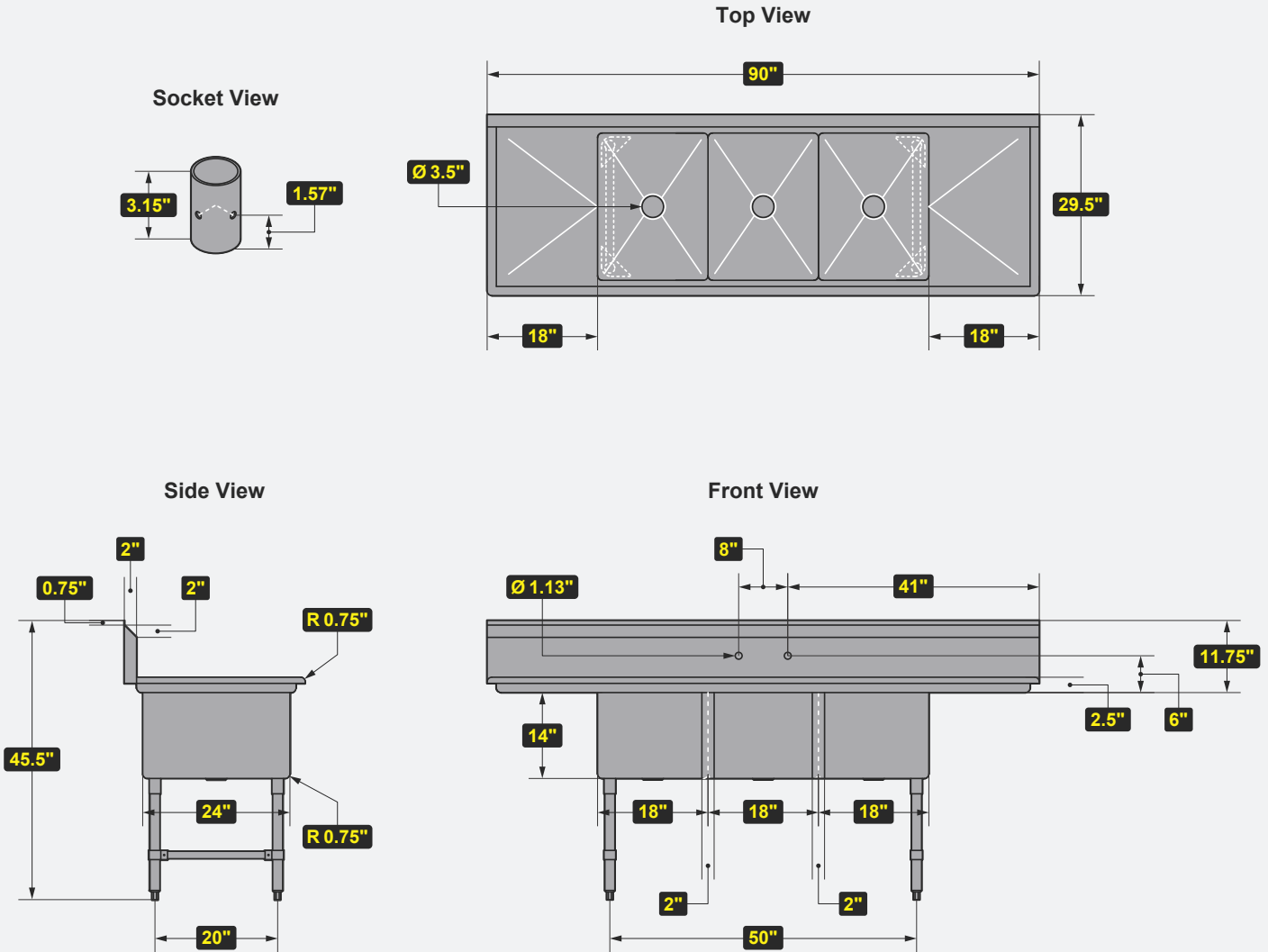

MODEL #	DESCRIPTION	DIMENSIONS (W x D x H)	WEIGHT/LBS. (Shipping)
E3CWP18242-18	14" Economy Sink	90" W x 29.5" D x 45.5" H	167 lbs.

# OF BOWLS	BOWL DIMENSIONS (W x D x H)	BACK SPLASH
3	18" W x 24" D x 14" H	N/A

DRAIN BOARDS

YES

Two 18"



Prop. 65 Warning for California Residents
 WARNING: This product may contain chemicals known to the State of California to cause cancer, birth defects, or other reproductive harm.

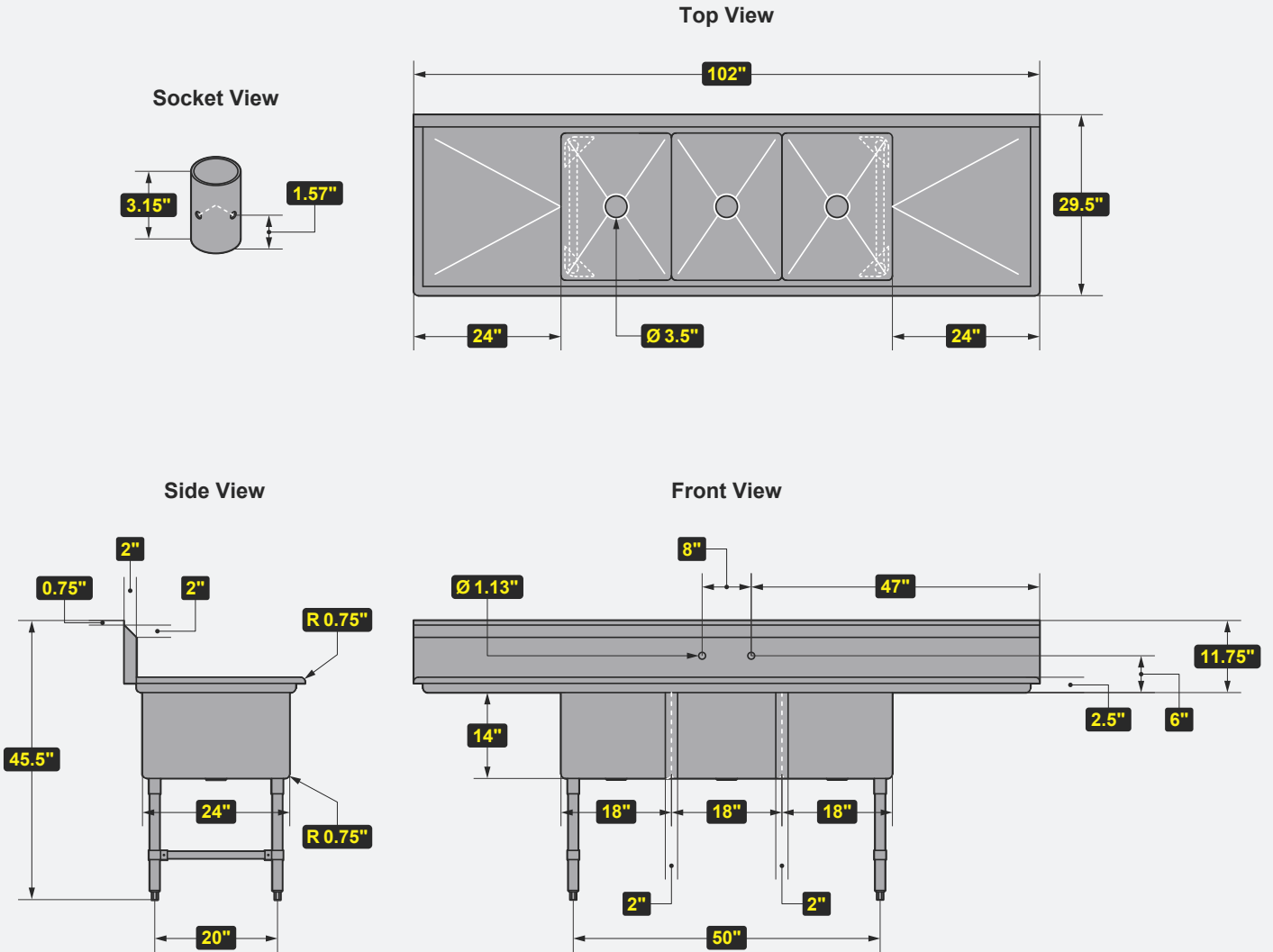

MODEL #	DESCRIPTION	DIMENSIONS (W x D x H)	WEIGHT/LBS. (Shipping)
E3CWP18242-24	14" Economy Sink	102" W x 29.5" D x 45.5" H	195 lbs.

# OF BOWLS	BOWL DIMENSIONS (W x D x H)	BACK SPLASH
3	18" W x 24" D x 14" H	N/A

DRAIN BOARDS

YES

Two 24"



Prop. 65 Warning for California Residents
 WARNING: This product may contain chemicals known to the State of California to cause cancer, birth defects, or other reproductive harm.



Phone: (800) 768.5953
 Fax: (800) 976.1299

Socket View

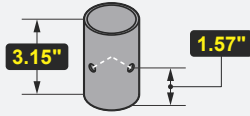

Top View

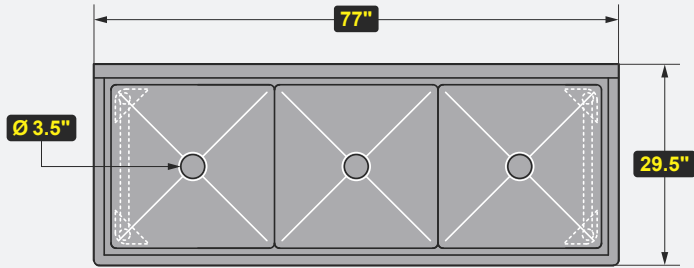

Side View

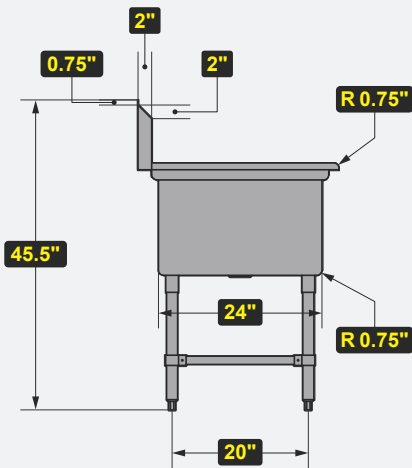

Front View

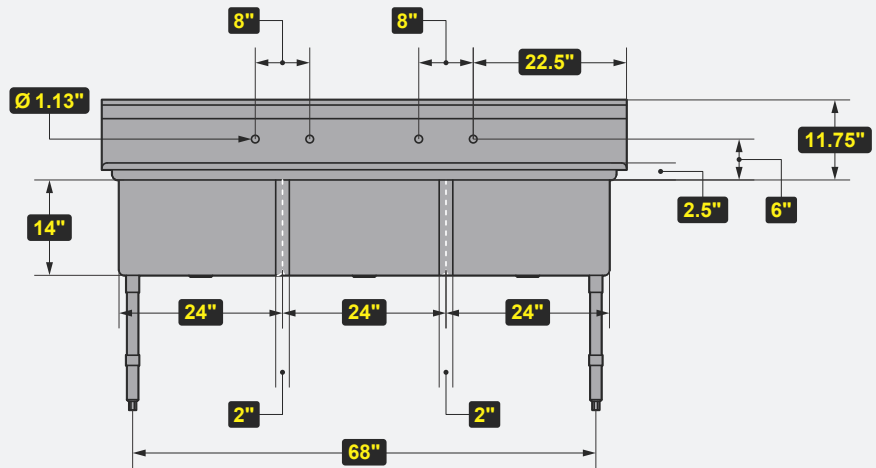

MODEL #	DESCRIPTION	DIMENSIONS (W x D x H)	WEIGHT/LBS. (Shipping)
E3CWP2424	14" Economy Sink	77" W x 29.5" D x 45.5" H	180 lbs.

# OF BOWLS	BOWL DIMENSIONS (W x D x H)	BACK SPLASH
3	24" W x 24" D x 14" H	N/A

DRAIN BOARDS
NO
N/A

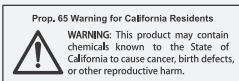

Phone:(800).768.5953
 Fax:(800).976.1299

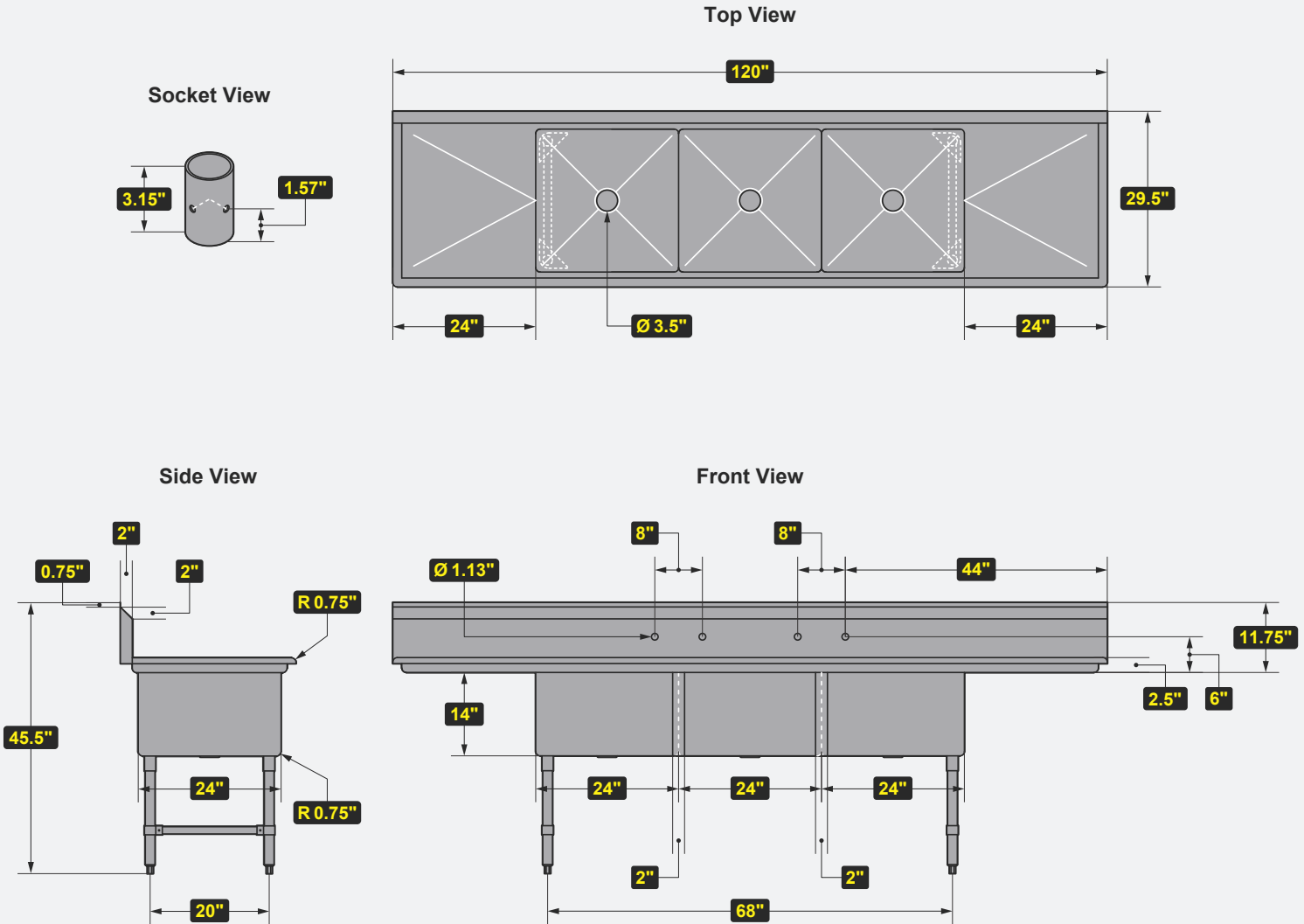

MODEL #	DESCRIPTION	DIMENSIONS (W x D x H)	WEIGHT/LBS. (Shipping)
E3CWP24242-24	14" Economy Sink	120" W x 29.5" D x 45.5" H	215 lbs.

# OF BOWLS	BOWL DIMENSIONS (W x D x H)	BACK SPLASH
3	24" W x 24" D x 14" H	N/A

DRAIN BOARDS

YES

Two 24"



Prop. 65 Warning for California Residents
 WARNING: This product may contain chemicals known to the State of California to cause cancer, birth defects, or other reproductive harm.

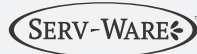

Phone:(800).768.5953
 Fax:(800).976.1299

Serv-Ware Sinks & Accessories

Notify carrier of damage! Inspect all components immediately.

Serv-Ware Products warrants to the original owner/user that any product manufactured shall be free of defects in material or workmanship, under normal use and maintenance, for a period of one (1) year from the original installation date or a maximum of eighteen (18) months after the shipment date from Serv-Ware Products. Proper installation and start-up in accordance with the instruction manual supplied will be taken into consideration when evaluating the warranty on the specified equipment.

This warranty does not include labor charges. Serv-Ware Products reserves the right to have any warranty "failed" parts returned to the factory for inspection before agreeing to covering the above stated warranty.

This warranty does not include parts coverage resulting from:

- Adverse operating conditions for the product.
- Failure to clean and/or maintain the product.
- Standard wear & tear items.
- Damage that is caused by employees or customers.
- Any part or assembly that has been altered, modified, or changed.
- Equipment usage in a residential or non-commercial setting.

LIMITATION OF LIABILITY AND OTHER WARRANTIES

Serv-Ware Products assumes no liability for misuse or inadequate maintenance of the Product. In no event shall the user be entitled to recover incidental or consequential damages. Including but not limited to; damages for inconvenience, food loss, rental or replacement equipment, loss of profits, or other commercial loss.

Warranties stated above are the only warranties made in connection with the sale and distribution of the Products. ANY AND ALL OTHER EXPRESSED STATUTORY AND IMPLIED WARRANTIES APPLICABLE TO THE PRODUCT INCLUDING, WITHOUT LIMITATION, ALL IMPLIED WARRANTIES OF MERCHANTABILITY AND FITNESS FOR USE ARE EXPRESSLY DISCLAIMED. The warranty information set forth above shall be governed by and construed in accordance with the laws of the State of North Carolina and, if applicable, the laws of the United States of America. The warranty, as stated, is extended only to the original owner/user and is not assignable. Serv-Ware reserves the right to change product specifications without notice due to constant product improvement.