

**Reviewed for Fire Code Compliance**



**Leslie Jackson**  
11/16/2023 2:05:38 PM

**DO NOT REMOVE!**

## Details: Appointment of Lien Agent

Entry #: 1994631

Filed on: 09/07/2023

Initially filed by: blakecon

### Designated Lien Agent

Chicago Title Company, LLC

**Online:** [www.liensnc.com](http://www.liensnc.com) (<http://www.liensnc.com>)

**Address:** 223 S. West Street, Suite 900 /  
Raleigh, NC 27603

**Phone:** 888-690-7384

**Fax:** 913-489-5231

**Email:** [support@liensnc.com](mailto:support@liensnc.com) (<mailto:support@liensnc.com>)

### Project Property

Cumberland County Hospitals Systems, Inc.  
D/B/A Cape Fear Valley Health Systems-  
Harnett Health-Lillington - Located at 215  
Brightwater Drive, Lillington, NC 27546 /  
Project Title: Cape Fear-Harnett Health-  
Siemens RF Room Renovation/Changeout  
215 Brightwater Drive  
Lillington, NC 27546  
Harnett County

### Print & Post



**Contractors:**

Please post this notice on the Job Site.

**Suppliers and Subcontractors:**

Scan this image with your smart phone to view this filing. You can then file a Notice to Lien Agent for this project.

### Owner Information

Blake Skarpalezos  
1994 Remount Road  
Gastonia, NC 28054  
United States  
Email: [blake@blakegc.com](mailto:blake@blakegc.com)  
Phone: 704-868-9930

### Property Type

Other

### Date of First Furnishing

09/07/2023

[View Comments \(0\)](#)

**Technical Support Hotline:** (888) 690-7384

# HARNETT HEALTH RAD ROOM 1318

an Interior Renovation for:

215 Brightwater Drive  
Lillington, North Carolina

**ARCHITECT**  
C.D. HAIR ARCHITECT L.L.C.  
8401 LAKE WORTH ROAD, SUITE 119  
LAKE WORTH, FLORIDA 33461  
(561) 209.6050  
chris@cdhairarchitect.com

**MECHANICAL ELECTRICAL**  
THOMPSON YOUNGROSS ENGINEERING CONSULTANTS  
902 CLINT MOORE ROAD, SUITE 142  
BOCA RATON, FLORIDA 33461  
(561) 274.0200  
artur@tecfia.com (Artur Amarel)

**GENERAL CONTRACTOR**  
BLAKE CONTRACTING  
1994 REMOUNT ROAD  
GASTONIA, NORTH CAROLINA 28054  
(704) 868.9930  
blake@blakegc.com (Blake Skarpalezos)



C.D. HAIR ARCHITECT  
8401 Lake Worth Road  
Suite 119  
Lake Worth, FL  
15034

revision:

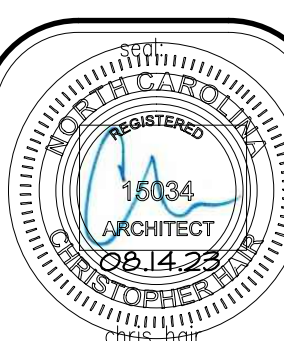

An Interior Renovation for:  
**Harnett Health  
RAD Room 1318 Renovation**  
215 Brightwater Drive  
Lillington, North Carolina

job no. 23-016  
principal: CHRIS HAIR  
CH

file name:  
date: 08.10.23  
title:

TITLE SHEET

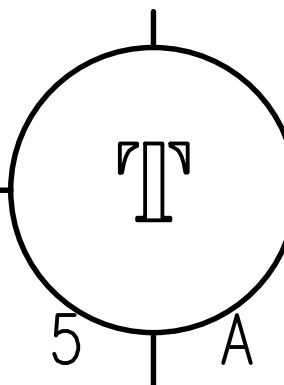

FINAL SUBMITTAL for construction

PROJECT SCOPE	PROJECT DATA	PROJECT CODE TABULAR		SHEET INDEX																		
<p>THE PROJECT INVOLVES AN EQUIPMENT CHANGE-OUT WITHIN AN EXISTING ROOM ON THE FIRST FLOOR WITHIN AN EXISTING IN-PATIENT, HOSPITAL. THE NEWLY RENOVATED SPACE WILL BE USED AS A RAD ROOM. (NO CHANGE TO THE EXISTING FUNCTION OF THE ROOM), NO NEW WALLS, DOORS OR OTHER LAYOUT CHANGES ARE IN THIS SCOPE OF THE RAD ROOM WORK. THE EXISTING FLOOR FINISHES SHALL BE REPLACED, THE EXISTING MILLWORK WILL REMAIN. THE EXISTING LIGHTING SHALL BE REPLACED. THE EXISTING HVAC SHALL REMAIN. THE BUILDING IS MULTI STORY AND ASSUMED TO BE TYPE I-B. THE SCOPE AREA IS PROTECTED BY A FULLY AUTOMATIC FIRE-SPRINKLER SYSTEM.</p> <p>DHSR PROJECT NO.: HL-12893</p> <p><b>VICINITY SKETCH</b> NOT TO SCALE</p>	<p><b>AREA CALCULATIONS:</b></p> <p>SCOPE AREA WITHIN EXIST. HOSPITAL 574 SF</p> <p><b>OCCUPANCY LOAD CALCULATIONS:</b></p> <p>INSTITUTIONAL I-2 574 S.F. / 240 GROSS = 2.39 (3 PEOPLE)</p>	<p><b>MUNICIPALITY:</b> HARNETT COUNTY</p> <p><b>GOVERNING CODES:</b> 2018 NORTH CAROLINA STATE BUILDING CODE BASED ON IBC - 2015 INTERNATIONAL BUILDING CODE W, AMENDMENTS IEBC - 2015 INTERNATIONAL EXISTING BUILDING CODE, '15 INTERNATIONAL FUEL GAS CODE, '15 INTERNATIONAL MECHANICAL CODE, '15 INTERNATIONAL PLUMBING CODE, 2018 FGI GUIDELINES OUTPATIENT FACILITIES, ICC / ANSI-A117.1-2013 ADA STANDARDS, 2017 NCSEC, 2005 U.S. PUBLIC HEALTH CODE, NORTH CAROLINA ADMIN. CODE, DHSR RULES AND REGULATIONS</p> <p><b>OCCUPANCY:</b> GROUP I-2 (INSTITUTIONAL)</p> <p><b>REQUIRED SEPARATION:</b> *NO SEPARATION REQUIRED TO ADJACENT GROUP 'I' TENANTS</p> <p><b>TYPE OF CONSTRUCTION:</b> TYPE I-B</p> <p><b>CLASSIFICATION OF WORK:</b> ALTERATION - LEVEL 2</p> <table border="1"> <thead> <tr> <th></th> <th>REQUIRED</th> <th>PROVIDED</th> </tr> </thead> <tbody> <tr> <td>MIN STAIR WIDTH:</td> <td>44"</td> <td>N/A</td> </tr> <tr> <td>MAX COMMON PATH OF TRAVEL:</td> <td>75'</td> <td>36'-3"</td> </tr> <tr> <td>MAX TRAVEL DISTANCE:</td> <td>200'</td> <td>105'-6"</td> </tr> <tr> <td>MAX DEAD END:</td> <td>20'</td> <td>N/A</td> </tr> <tr> <td>NO. OF EXITS:</td> <td>2</td> <td>2</td> </tr> </tbody> </table> <p>* BUILDING IS PROVIDED WITH A FULLY AUTOMATIC SPRINKLER SYSTEM</p>		REQUIRED	PROVIDED	MIN STAIR WIDTH:	44"	N/A	MAX COMMON PATH OF TRAVEL:	75'	36'-3"	MAX TRAVEL DISTANCE:	200'	105'-6"	MAX DEAD END:	20'	N/A	NO. OF EXITS:	2	2	<p>REV DATE</p>	<p><b>ARCHITECTURAL:</b></p> <p>T TITLE SHEET A010 LIFE SAFETY PLAN A210 DEMO AND FLOOR PLAN A410 DEMO AND REFLECTED CEILING PLAN A910 ICRA COORDINATION PLAN</p> <p><b>ELECTRICAL:</b></p> <p>E0.1 ELECTRICAL NOTES, LEGEND AND SCHEDULES E1.1 FIRST FLOOR ELECTRICAL PLAN E2.1 FIRST FLOOR LIGHTING PLAN E3.1 SIEMENS REFERENCE DESIGN PLANS E3.2 SIEMENS REFERENCE DESIGN PLANS</p> <p><b>MECHANICAL:</b></p> <p>M1.1 FIRST FLOOR MECHANICAL PLAN</p>
	REQUIRED	PROVIDED																				
MIN STAIR WIDTH:	44"	N/A																				
MAX COMMON PATH OF TRAVEL:	75'	36'-3"																				
MAX TRAVEL DISTANCE:	200'	105'-6"																				
MAX DEAD END:	20'	N/A																				
NO. OF EXITS:	2	2																				
<p><b>BUILDING KEY PLAN</b></p>		<p><b>LIFE SAFETY CODE</b></p>																				
<p>SCOPE AREA WITHIN BUILDING</p>		<p><b>GOVERNING CODES:</b> 2015 INTERNATIONAL FIRE CODE NCBC - FPC NFPA 101 LIFE SAFETY CODE - 2012 ED. NFPA 13 LIFE SAFETY CODE - STANDARD FOR THE INSTALLATION OF SPRINKLER SYSTEMS 2013 ED.</p> <p><b>OCCUPANCY:</b> (INSTITUTIONAL)</p> <table border="1"> <thead> <tr> <th></th> <th>REQUIRED</th> <th>PROVIDED</th> </tr> </thead> <tbody> <tr> <td>MAX COMMON PATH OF TRAVEL:</td> <td>75'</td> <td>36'-3"</td> </tr> <tr> <td>MAX TRAVEL DISTANCE:</td> <td>200'</td> <td>105'-6"</td> </tr> <tr> <td>MAX DEAD END:</td> <td>20'</td> <td>N/A</td> </tr> </tbody> </table> <p>* BUILDING IS PROVIDED WITH A FULLY AUTOMATIC SPRINKLER SYSTEM</p>		REQUIRED	PROVIDED	MAX COMMON PATH OF TRAVEL:	75'	36'-3"	MAX TRAVEL DISTANCE:	200'	105'-6"	MAX DEAD END:	20'	N/A								
	REQUIRED	PROVIDED																				
MAX COMMON PATH OF TRAVEL:	75'	36'-3"																				
MAX TRAVEL DISTANCE:	200'	105'-6"																				
MAX DEAD END:	20'	N/A																				

revision:

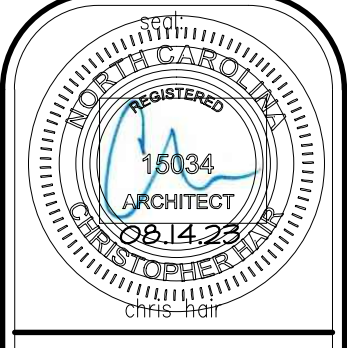

An Interior Renovation for:  
**Harnett Health**  
**RAD Room 1318 Renovation**  
 215 Brighwater Drive  
 Lillington, North Carolina

job no.	23-016
principal:	CHRIS HAIR CH
file name:	
date:	08.10.23
title:	LIFE SAFETY PLAN

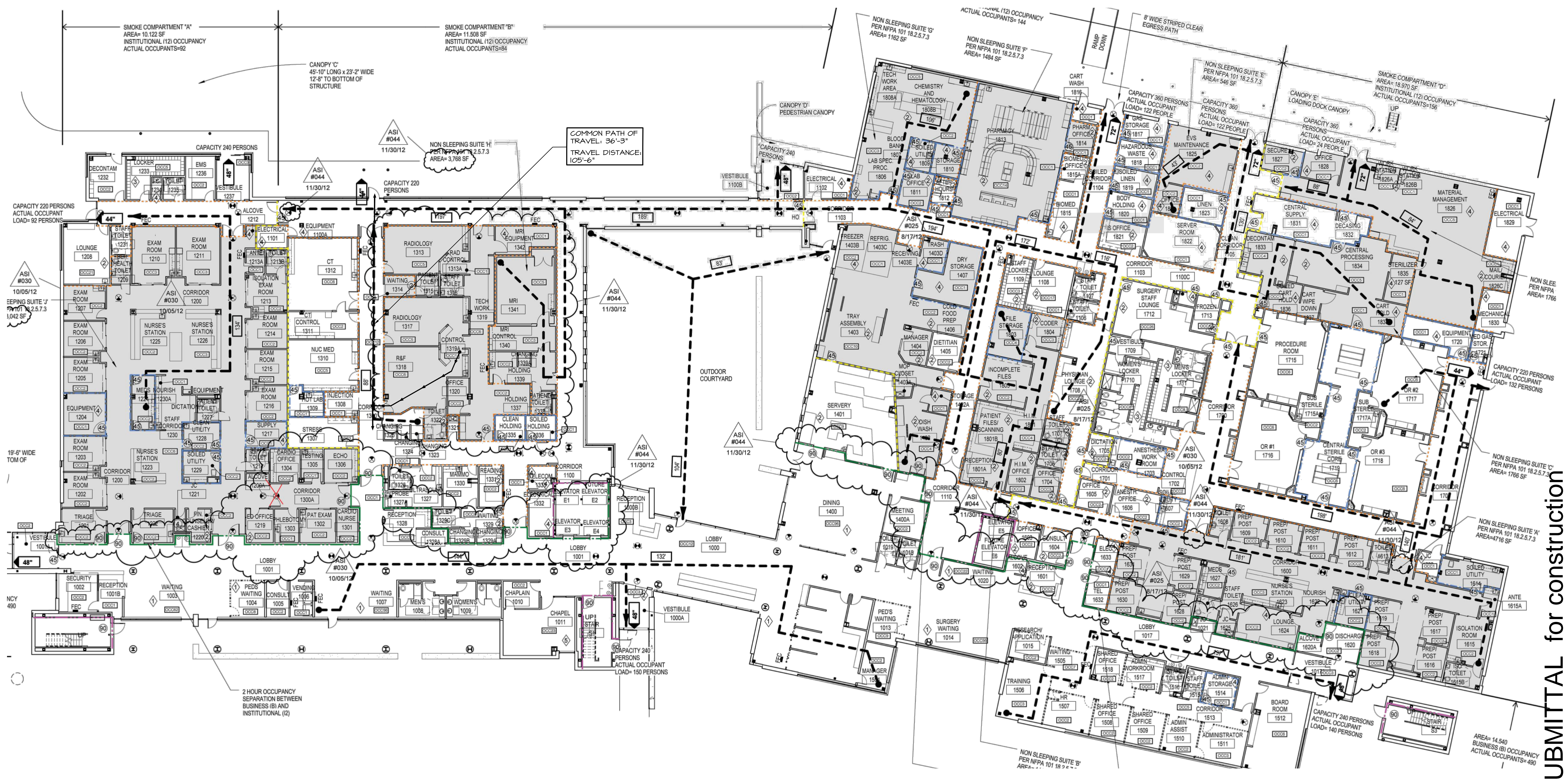

**LIFE SAFETY PLAN**  
 1/32" = 1'-0"

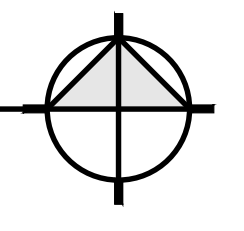

FINISH SCHEDULE						REMARKS
ROOM #	DESCR.	FLOOR	WALLS	BASE	CEILING	
1310	EXAM ROOM	SV-1	PT-1	CB-1	AC-1	
1310A	CONTROL	SV-1	PT-1	CB-1	EX	
1322	RESTROOM	SV-1	PT-1	CB-1	EX	
<b>ABBREV.</b> UNO = UNLESS OTHERWISE NOTED, MS = MANUFACTURER STANDARD, EX = EXISTING, EXP = EXPOSED <b>NOTES</b> ALL FINISHES TO BE VERIFIED BY OWNER PRIOR TO PURCHASE AND INSTALL.						

MANUFACTURER SPECIFICATIONS			
DESCR.	MANUF.	MODEL	REMARKS
SHEET VINYL (SV-1)	ME	ME	MATCH EXISTING ADJACENT
COVE BASE (CB-1)	ME	ME	4" INTEGRAL FLASH COVE BASE
PAINT (PT-1)	ME	LATEX PAINT	MATCH EXISTING ADJACENT
PAINT (PT-2)	ME	LATEX PAINT	MATCH EXISTING ADJACENT
<b>ABBREV.</b> UNO = UNLESS OTHERWISE NOTED, MS = MANUFACTURER STANDARD, EX = EXISTING, EXP = EXPOSED, ME = MATCH EXISTING <b>NOTES</b> ALL FINISHES TO BE VERIFIED BY OWNER PRIOR TO PURCHASE AND INSTALL.			

**DEMOLITION NOTES:**

- ITEMS SCHEDULED TO BE DEMOLISHED SHALL BE REMOVED IN THEIR ENTIRETY, INCLUDING INSTALLATIONS ABOVE THE CEILING. EXISTING WALLS SHALL BE PATCHED WHERE ITEMS WERE REMOVED TO MATCH ADJACENT SURFACES.
- DUST BARRIERS SHALL BE CONSTRUCTED AND MAINTAINED THROUGH THE COURSE OF CONSTRUCTION TO MINIMIZE THE SPREAD OF CONSTRUCTION DUST.
- PROTECT EXISTING WALLS TO REMAIN. ALL EXISTING WALLS TO REMAIN TO BE FINISHED TO ACHIEVE 'AS NEW' APPEARANCE.
- CONTRACTOR TO PROTECT OR REMOVE CEILING TILE AS REQUIRED IN AREAS WHERE EQUIPMENT IS BEING INSTALLED.
- PATCH EXISTING CEILINGS AS REQUIRED DUE TO INSTALLATION OF OVERHEAD EQUIPMENT.
- REMOVE EXISTING LIGHTING AS SCHEDULED. EXISTING FIRE SPRINKLER HEADS TO BE LEFT INTACT.

**SYMBOL LEGEND:**

- EXISTING WALL TO REMAIN
- EXISTING WINDOW TO REMAIN
- EXISTING DOOR TO REMAIN

**PLAN NOTES:**

- CONTRACTORS TO VERIFY ALL FIELD CONDITIONS PRIOR TO COMMENCEMENT AND REPORT ANY DISCREPANCIES TO THE ARCHITECT
- ALL PENETRATIONS, NEW AND EXISTING THROUGH RATED PARTITIONS MUST MEET UL APPROVED STANDARDS - SUBMIT SYSTEM TO ARCHITECT FOR APPROVAL. FIELD VERIFY PRIOR TO BID.
- PROVIDE SOLID WOOD BACKING FOR ALL WALLS TO RECEIVE COUNTERS, CABINETS, DOOR STOPS, SINKS, TOILET ACCESSORIES, CHAIR RAILS, AND OTHER RELATED INSTALLATIONS. THE INSTALLATIONS SHALL BE INSPECTED BY THE ARCHITECT PRIOR TO COVERING WITH DRYWALL.
- THE NOTE HOLD ON DIMENSION STRINGS INDICATE MINIMUM CLEAR FINISH DIMENSIONS.
- PENETRATIONS THROUGH FIRE RATED PARTITIONS WILL BE FIRE CAULKED WITH THE UL SYSTEM NO. W-L-1044.

**FINISH NOTES:**

- ALL FINISHES SHALL MEET THE REQUIREMENTS OF NCBC 2010 CHAPTER 0, TABLE 003.11:
  - VERTICAL EXITS AND EXIT PASSAGEWAYS - CLASS B
  - EXIT ACCESS CORRIDORS AND OTHER EXIT WAYS - CLASS C
  - ROOMS AND ENCLOSED SPACES - CLASS C
- ALL FINISHES TO BE APPROVED BY TENANT PRIOR TO INSTALLATION.
- PROVIDE APPROPRIATE HANDICAP ACCESSIBLE THRESHOLDS WHERE FLOOR CHANGES MATERIAL.
- SEE FINISH SCHEDULE FOR PLASTIC LAMINATE COLORS.
- ALL EXISTING DRYWALL WALLS WITHIN THE SCOPE AREA SHALL BE PAINTED W/ TWO COATS FLAT FINISH LATEX PAINT AS REQUIRED TO COVER. ALL WALLS SHALL THEN BE PAINTED WITH ONE COLOR, ONE COAT, SEE FINISH SCHEDULE FOR COLORS.
- THE EXISTING DOORS SHALL BE REFINISHED TO MATCH THE EXISTING ADJACENT.
- PROVIDE MINIMUM CLASS II FLOOR FINISH MATERIALS TO COMPLY WITH MINIMUM CRITICAL RADIANT FLUX IN EXIT PASSAGEWAYS AND CORRIDORS. ALL OTHER AREAS MUST COMPLY WITH THE DOC FF-1 'PULL-TEST' (FPC 16 CFR, PART 1630)
- PAINT NEW EXPOSED ELECTRICAL CABLE DUCTING AND CONDUIT, COLOR TO MATCH WALLS.
- PAINT DOOR AND WINDOW FRAMES WITH TWO COATS SEMI GLOSS LATEX PAINT.

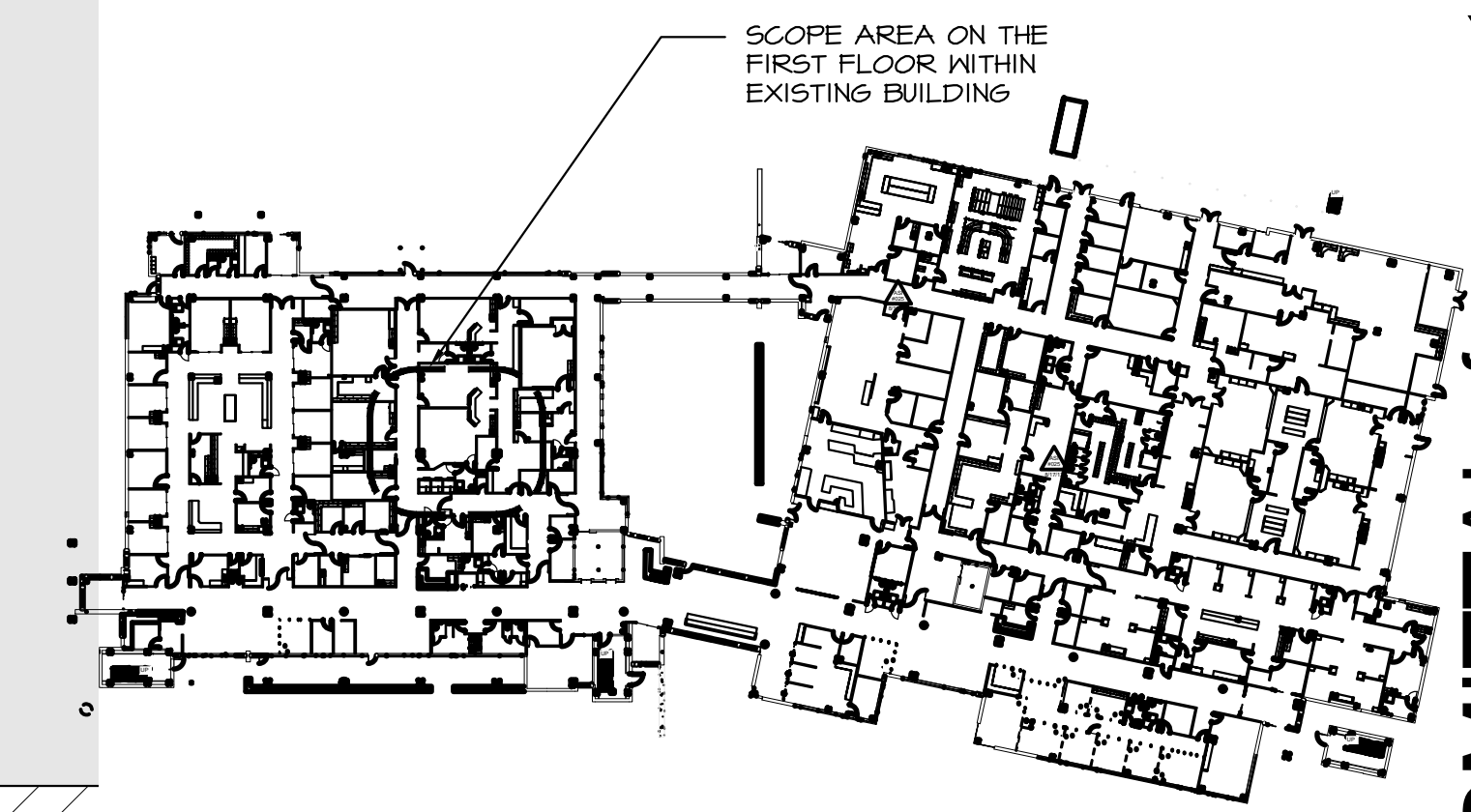
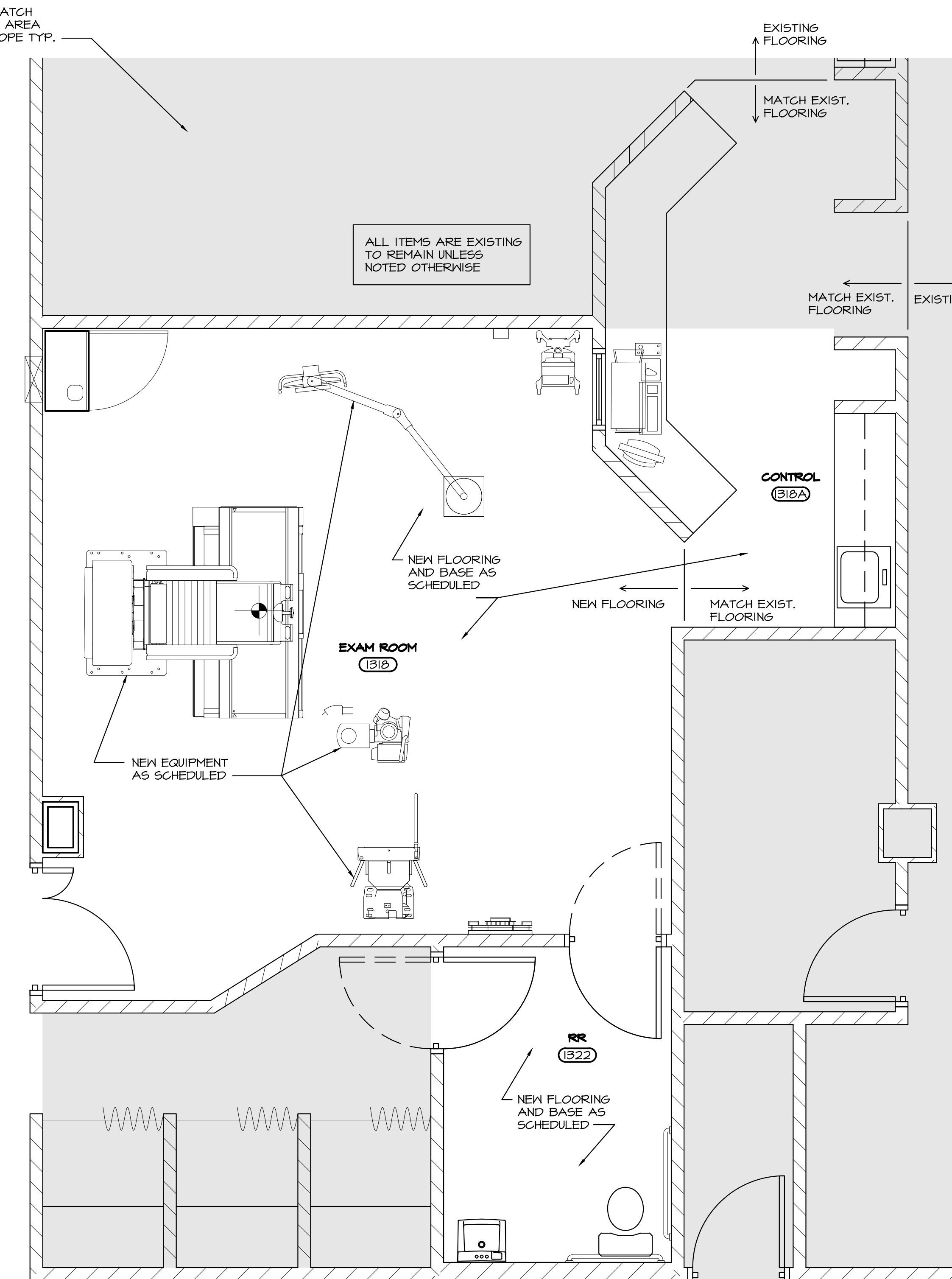
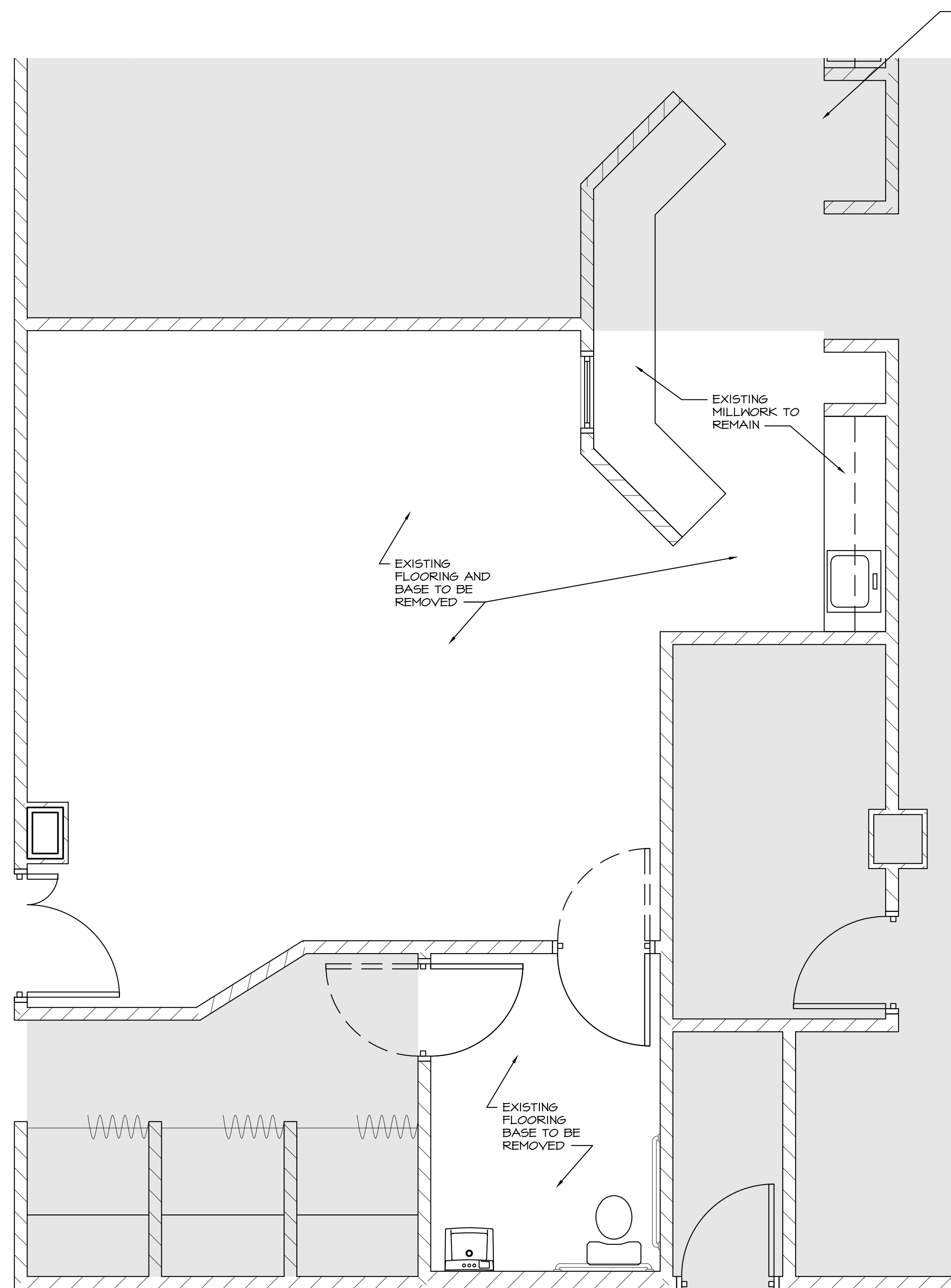

**DEMOLITION PLAN**  
3/8"=1'-0"

**FIRST FLOOR PLAN**  
3/8"=1'-0"

**OVERALL FIRST FLOOR PLAN**  
NTS

**C.D. HAIR ARCHITECT**  
8401 Lake Worth Road  
Suite 119  
Lake Worth, FL  
15034

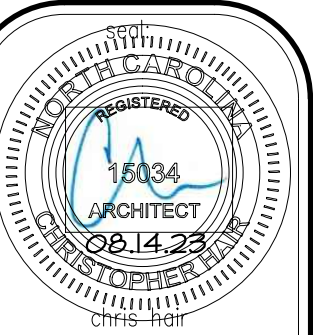





An Interior Renovation for:  
**Harnett Health  
RAD Room 1318 Renovation**  
215 Brighthwater Drive  
Lillington, North Carolina

**FINAL SUBMITTAL for construction**



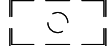

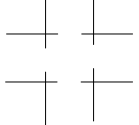
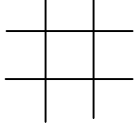
job no. 23-016  
principal: CHRIS HAIR  
CH  
file name:  
date: 08.10.23  
title: DEMO AND FLOOR PLAN

**A210**  
5 A

**CEILING DEMOLITION LEGEND:**

-  EXISTING LIGHT FIXTURE TO BE REMOVED
-  EXISTING LIGHT FIXTURE TO BE SALVAGED FOR REINSTALLATION
-  EXISTING SUPPLY REGISTER TO BE SALVAGED FOR REINSTALLATION
-  EXISTING RETURN REGISTER TO BE SALVAGED FOR REINSTALLATION
-  EXISTING ACOUSTICAL CEILING AND GRID TO BE REMOVED
-  EXISTING CEILING AND INSTALLATIONS TO REMAIN
-  EXISTING FIRE SPRINKLER HEAD TO BE SALVAGED FOR REINSTALLATION

**CEILING LEGEND:**

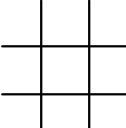
-  EXISTING REINSTALLED 2' x 4' LED LIGHT FIXTURE
  -  NEW 6" RECESSED DIMMABLE LED CAN LIGHT FIXTURE
  -  EXISTING REINSTALLED SUPPLY REGISTER
  -  EXISTING REINSTALLED RETURN REGISTER
  -  EXISTING REINSTALLED FIRE SPRINKLER HEAD
  -  NEW 2 X 2 CEILING IN NEW GRID - PROVIDE TILE AS SPECIFIED
- D = DIMMABLE

**CEILING NOTES:**

1. ALL CEILING MOUNTED ITEMS, INCLUDING LIGHTS, AND HVAC REGISTERS, SHALL BE CENTERED IN THE TILE. ANY CONFLICTS SHALL BE REPORTED TO THE ARCHITECT UPON DISCOVERY. UNDER NO CIRCUMSTANCES SHALL ANY ITEM BE RELOCATED WITHOUT THE ARCHITECT'S APPROVAL.
2. ALL RECTANGULAR ROOMS SHALL HAVE EQUAL BORDERS UNLESS NOTED OTHERWISE. SEE THE PLANS FOR DENOTED STARTING POINTS AND POINTS OF ALIGNMENT.
3. ALL CEILING HEIGHTS FOR SUSPENDED CEILINGS ARE INDICATED ON THE CEILING PLAN.
4. ALL NEW CEILING GRID SHALL BE ATTACHED TO THE ROOF / FLOOR JOISTS ABOVE AT 4'-0" O.C. (MAX) WITH ASTM A641, CLASS 1 ZINC COATED, SOFT TEMPER, PRE-STRETCHED HANGER WIRE (12 GA) MINIMUM. ALL HANGER WIRE SHALL BE INSTALLED PLUMB AND STRAIGHT. GRID SUSPENSION SYSTEM TO MEET ASTM 635-636.

**C.D. HAIR ARCHITECT**  
 8401 Lake Worth Road  
 Suite 119  
 Lake Worth, FL  
**15034**

revision:

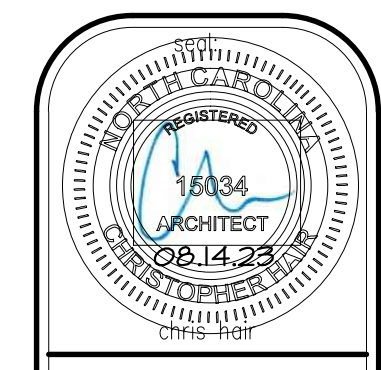
An Interior Renovation for:  
**Harnett Health**  
**RAD Room 1318 Renovation**  
 215 Brighthwater Drive  
 Lillington, North Carolina

FINAL SUBMITTAL for construction



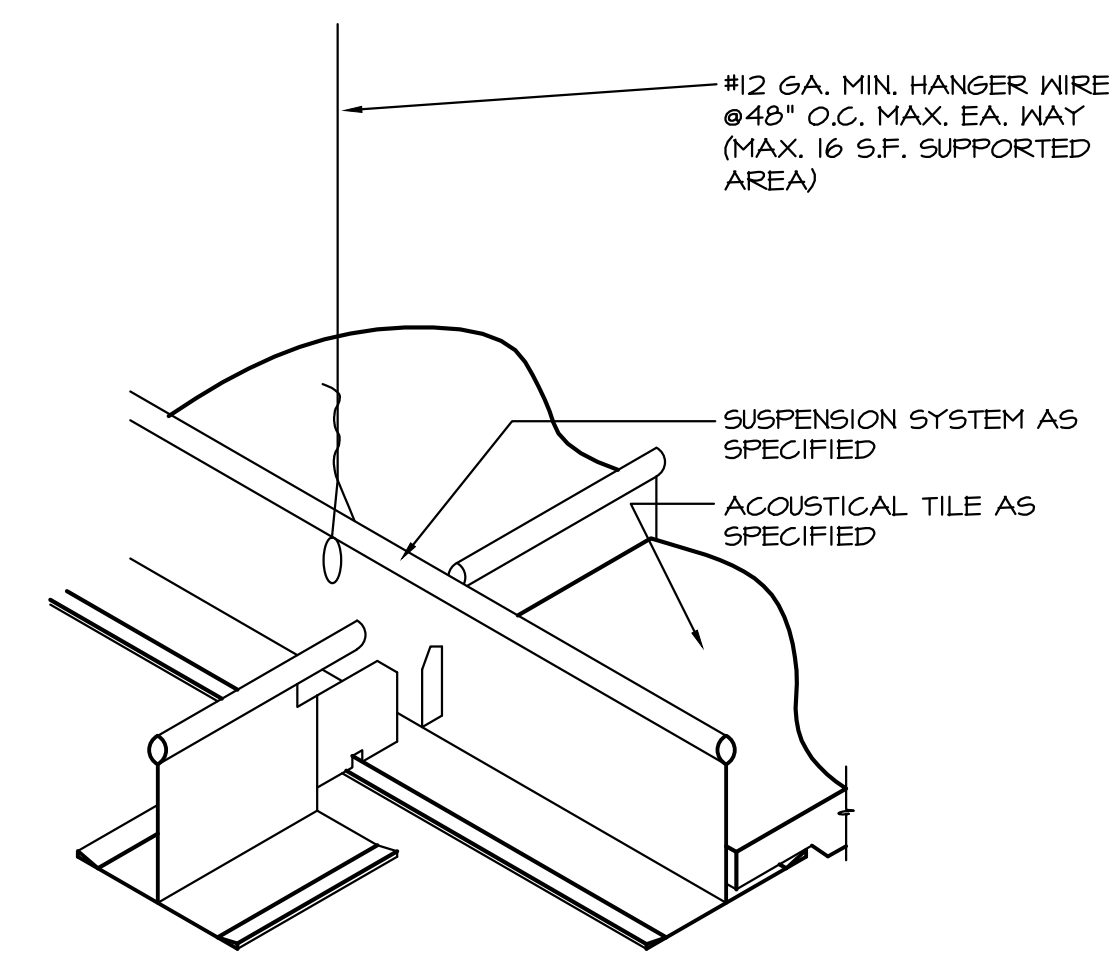
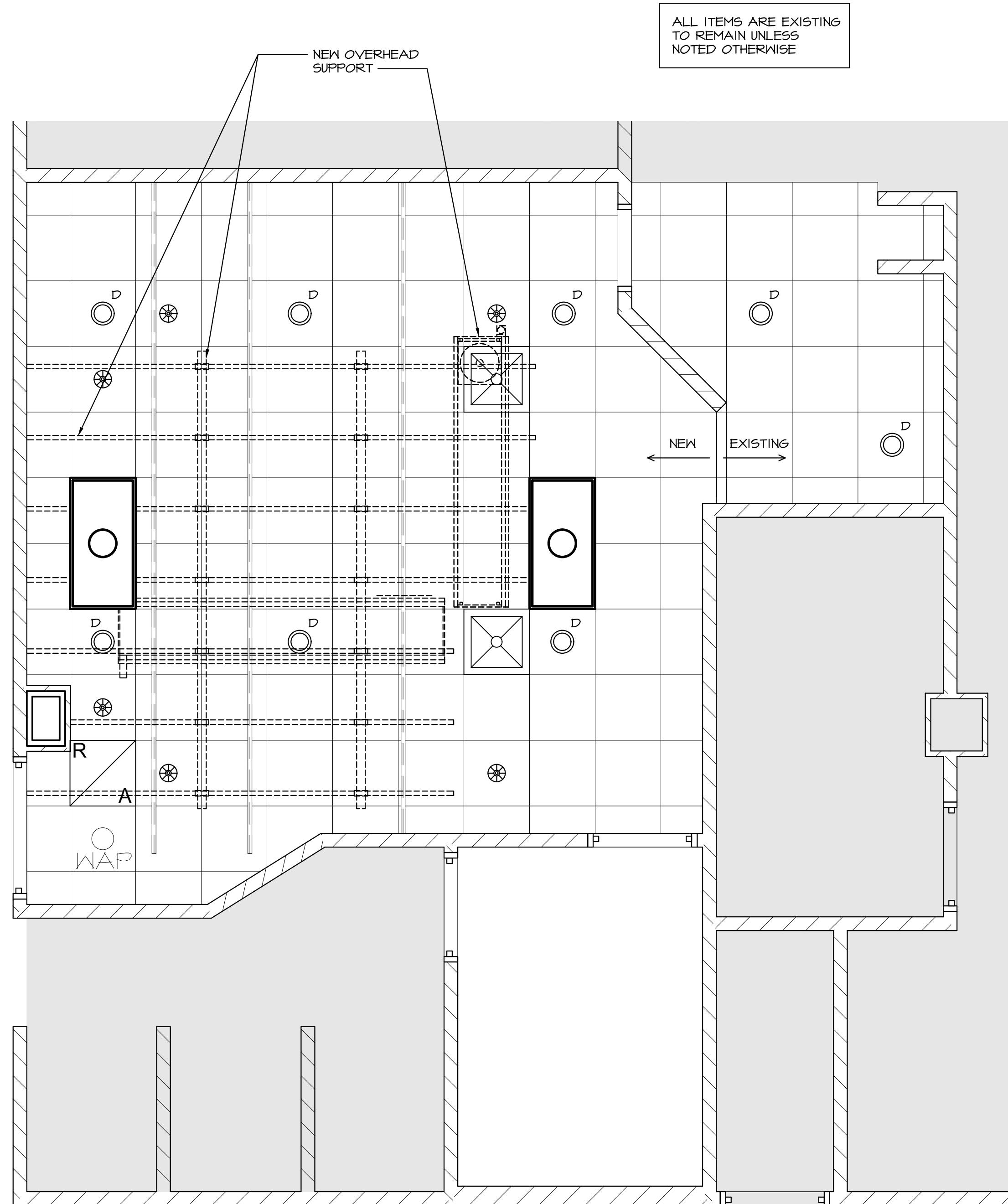
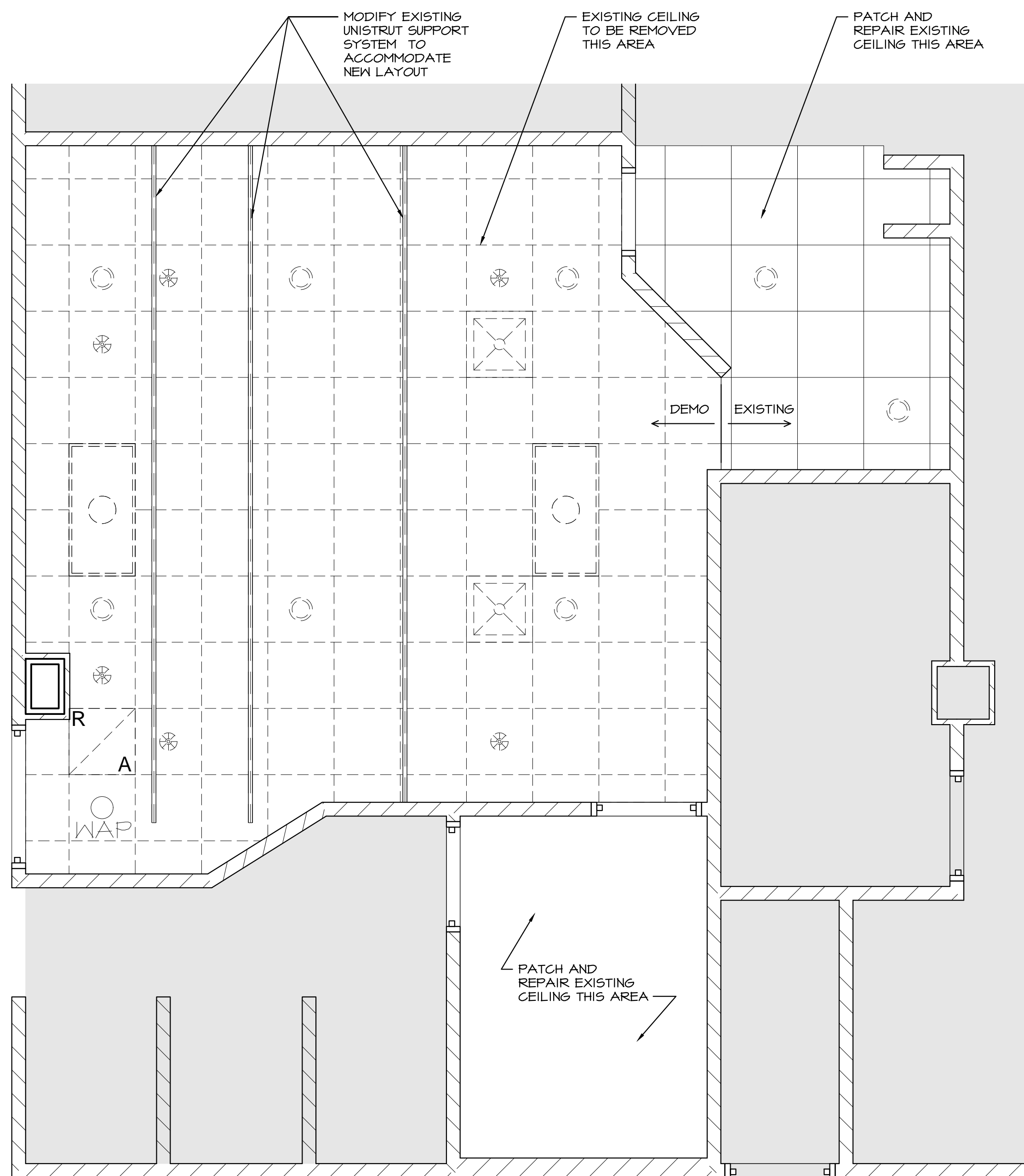

**DEMOLITION CEILING PLAN**  
 3/8" = 1'-0"

**REFLECTED CEILING PLAN**  
 3/8" = 1'-0"

**CEILING GRID DETAIL**  
 3" = 1'-0"

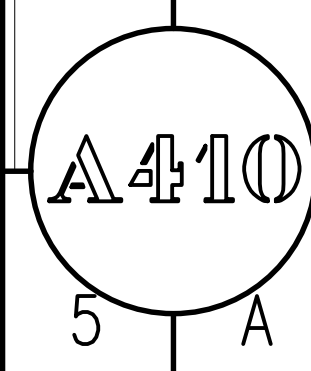
job no. **23-016**  
 principal: **CHRIS HAIR**  
 CH  
 file name:  
 date: **08.10.23**  
 title: **DEMO AND REFLECTED CEILING PLAN**



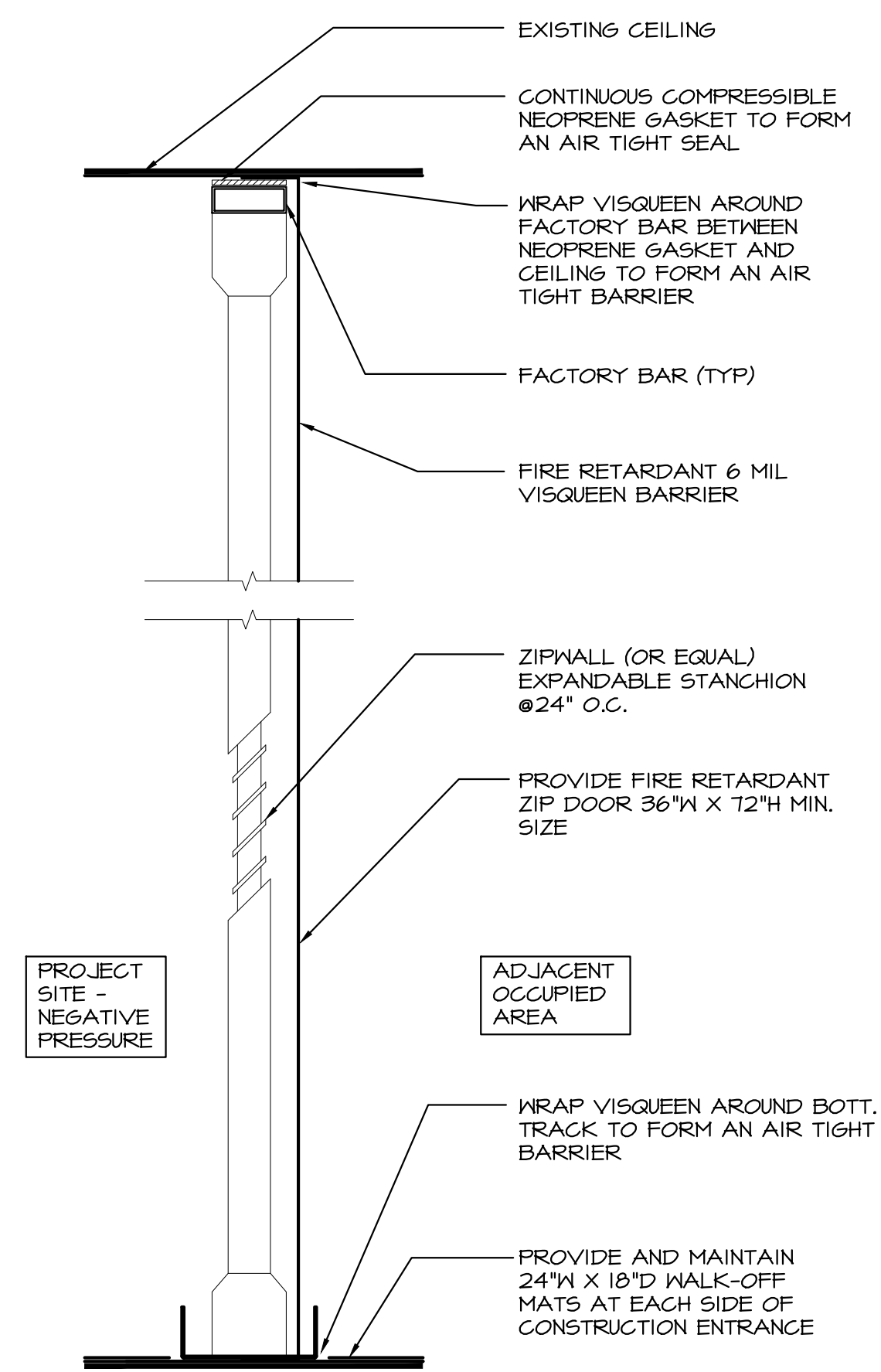

**TEMPORARY ZIPWALL CONTAINMENT BARRIER**  
 3" = 1'-0"  
 01.24.01-001 A910

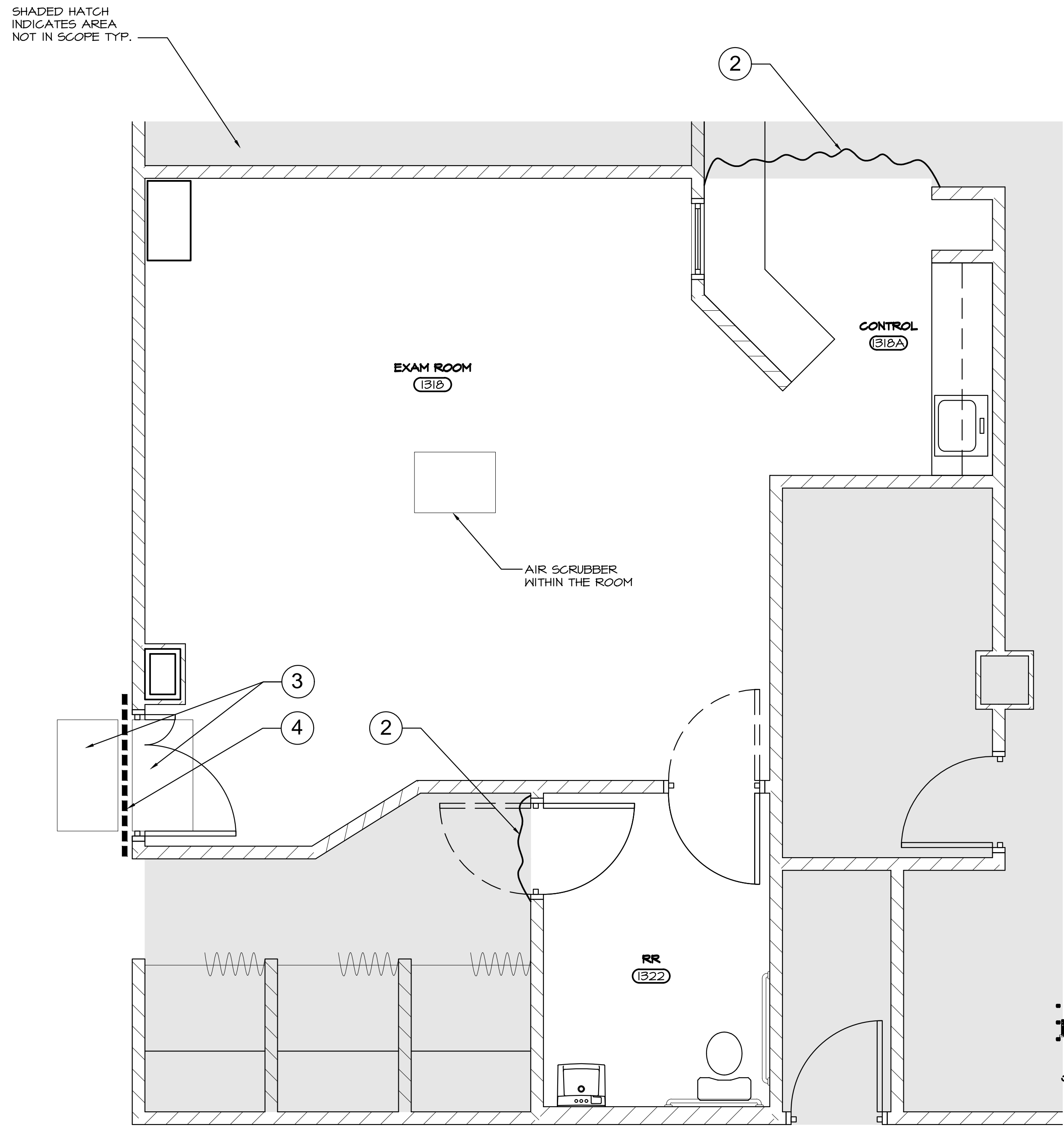

**ICRA COORDINATION PLAN**  
 3/8" = 1'-0"

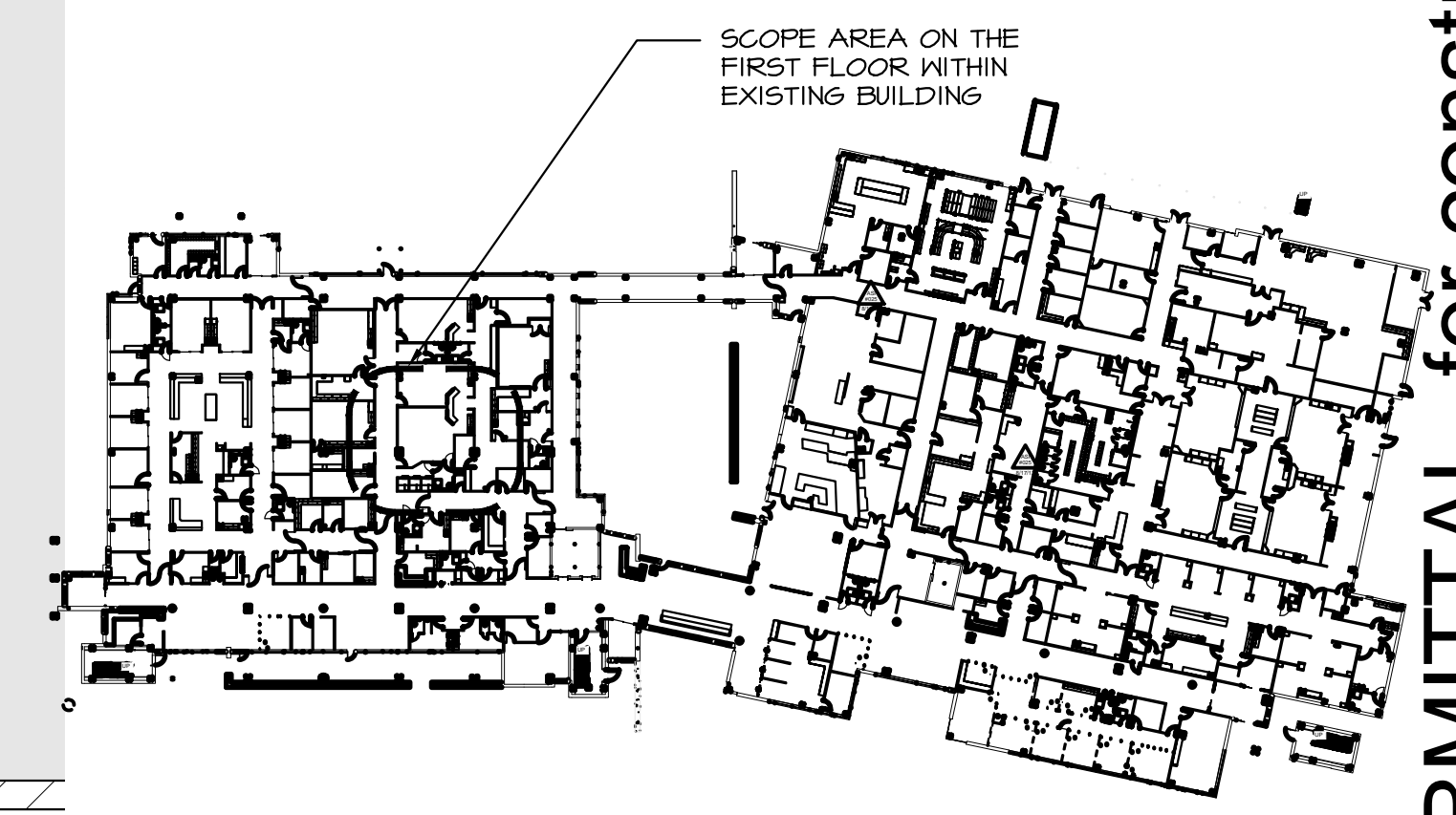

**OVERALL FIRST FLOOR PLAN**  
 NTS

**ICRA PLAN NOTES**

1. THE GENERAL CONTRACTOR SHALL BECOME FAMILIAR WITH THE PROJECT SITE AND NOTIFY THE ARCHITECT IMMEDIATELY OF DISCREPANCIES.

**PLAN KEYNOTES**

① PRIOR TO CONSTRUCTION, SEAL OFF APPLICABLE SITE SUPPLY AND RETURN AIR DIFFUSERS AND GRILLES TO MINIMIZE DUST CONTAMINATION OF DUCTWORK AND SURROUNDING AREAS. PROVIDE NEGATIVE PRESSURE WITHIN THE PROJECT AREA RELATIVE TO THE AREAS SURROUNDING THE PROJECT AREA AS WELL AS HEPA AIR FILTRATION. PROVIDE MEANS OF MONITORING THE AIR PRESSURE FOR THE ENTIRE DURATION OF CONSTRUCTION.

② SEAL EXISTING AREA WITH FIRE RETARDANT VISQUEEN ABOVE THE CEILING. TAPE PERIMETER SUCH THAT AN AIR TIGHT BARRIER IS ACHIEVED.

③ PROVIDE WALK-OFF MAT

④ PROVIDE TEMPORARY ZIPWALL CONTAINMENT BARRIER

**ICRA CLASSIFICATION DATA**

CONSTRUCTION TYPE: I-B  
 CONSTRUCTION CLASS: II  
 RISK CLASS: MEDIUM

CONSTRUCTION PROTOCOLS

DURING CONSTRUCTION	UPON COMPLETION
1. SEAL SITE SUPPLY AND RETURN AIR DIFFUSERS.	1. DO NOT REMOVE BARRIERS FROM WORK AREA UNTIL COMPLETED PROJECT IS INSPECTED BY THE OWNERS SAFETY DEPARTMENT AND INFECTION CONTROL DEPARTMENT AND THOROUGHLY CLEANED BY THE OWNERS ENVIRONMENTAL SERVICES DEPARTMENT.
2. INSTALL TEMPORARY ZIPWALL BARRIER AS SHOWN ON DETAIL 1, THIS SHEET.	2. REMOVE BARRIER MATERIALS CAREFULLY TO MINIMIZE SPREADING OF DIRT AND DEBRIS ASSOCIATED WITH CONSTRUCTION.
3. PROVIDE A TEMPORARY NEGATIVE AIR UNIT WITH HEPA FILTRATION TO PLACE PROJECT SITE AT NEGATIVE PRESSURE.	3. VACUUM WORK AREA WITH HEPA FILTERED VACUUMS.
4. PROVIDE SHOE COVERS AND TEMPORARY WALK OFF ADHESIVE MATS AT EXIT OF PROJECT AREA.	4. WET MOP AREA WITH DISINFECTANT.
5. CONTAIN CONSTRUCTION WASTE BEFORE TRANSPORT IN TIGHTLY COVERED CONTAINERS.	5. REMOVE ISOLATION OF HVAC SYSTEM IN AREAS WHERE WORK IS BEING PERFORMED.

**C.D. HAIR ARCHITECT**  
 8401 Lake Worth Road  
 Suite 119  
 Lake Worth, FL  
 15034

revision:

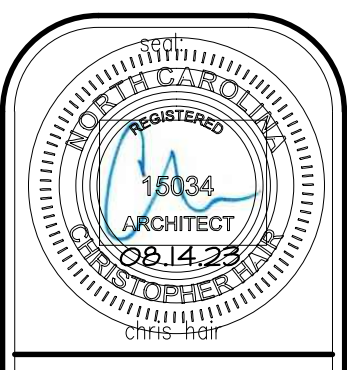
An Interior Renovation for:  
**Harnett Health  
 RAD Room 1318 Renovation**  
 215 Brighthwater Drive  
 Lillington, North Carolina

FINAL SUBMITTAL for construction

job no. 23-016  
 principal: CHRIS HAIR  
 CH  
 file name:  
 date: 08.10.23  
 title: ICRA COORDINATION PLAN

A910  
 5 A

# HARNETT HEALTH RAD ROOM 1318

an Interior Renovation for:

215 Brightwater Drive  
Lillington, North Carolina

**ARCHITECT**  
C.D. HAIR ARCHITECT L.L.C.  
8401 LAKE WORTH ROAD, SUITE 119  
LAKE WORTH, FLORIDA 33461  
(561) 209.6050  
chris@cdhairarchitect.com

**MECHANICAL ELECTRICAL**  
THOMPSON YOUNGROSS ENGINEERING CONSULTANTS  
902 CLINT MOORE ROAD, SUITE 142  
BOCA RATON, FLORIDA 33461  
(561) 274.0200  
artur@tecfla.com (Artur Amarel)

**GENERAL CONTRACTOR**  
BLAKE CONTRACTING  
1994 REMOUNT ROAD  
GASTONIA, NORTH CAROLINA 28054  
(704) 868.9930  
blake@blakegc.com (Blake Skarpalezos)



C.D. HAIR ARCHITECT  
8401 Lake Worth Road  
Suite 119  
Lake Worth, FL  
15034

revision:

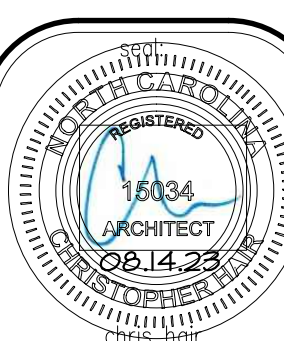

An Interior Renovation for:  
**Harnett Health  
RAD Room 1318 Renovation**  
215 Brightwater Drive  
Lillington, North Carolina

job no. 23-016  
principal: CHRIS HAIR  
CH

file name:

date: 08.10.23  
title:

TITLE SHEET

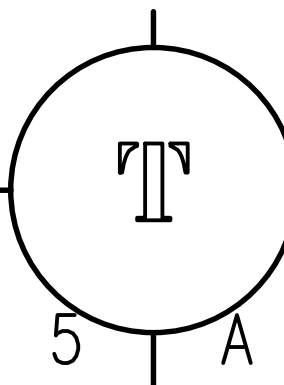

FINAL SUBMITTAL for construction

PROJECT SCOPE		PROJECT DATA		PROJECT CODE TABULAR			SHEET INDEX																				
<p>THE PROJECT INVOLVES AN EQUIPMENT CHANGE-OUT WITHIN AN EXISTING ROOM ON THE FIRST FLOOR WITHIN AN EXISTING IN-PATIENT, HOSPITAL. THE NEWLY RENOVATED SPACE WILL BE USED AS A RAD ROOM. (NO CHANGE TO THE EXISTING FUNCTION OF THE ROOM), NO NEW WALLS, DOORS OR OTHER LAYOUT CHANGES ARE IN THIS SCOPE OF THE RAD ROOM WORK. THE EXISTING FLOOR FINISHES SHALL BE REPLACED, THE EXISTING MILLWORK WILL REMAIN. THE EXISTING LIGHTING SHALL BE REPLACED. THE EXISTING HVAC SHALL REMAIN. THE BUILDING IS MULTI STORY AND ASSUMED TO BE TYPE I-B. THE SCOPE AREA IS PROTECTED BY A FULLY AUTOMATIC FIRE-SPRINKLER SYSTEM.</p> <p>DHSR PROJECT NO.: HL-12893</p> <p><b>VICINITY SKETCH</b> NOT TO SCALE</p>		<p><b>AREA CALCULATIONS:</b></p> <p>SCOPE AREA WITHIN EXIST. HOSPITAL 574 SF</p> <p><b>OCCUPANCY LOAD CALCULATIONS:</b></p> <p>INSTITUTIONAL I-2 574 S.F. / 240 GROSS = 2.39 (3 PEOPLE)</p>		<p><b>MUNICIPALITY:</b> HARNETT COUNTY</p> <p><b>GOVERNING CODES:</b> 2018 NORTH CAROLINA STATE BUILDING CODE BASED ON IBC - 2015 INTERNATIONAL BUILDING CODE W, AMENDMENTS IEBC - 2015 INTERNATIONAL EXISTING BUILDING CODE, '15 INTERNATIONAL FUEL GAS CODE, '15 INTERNATIONAL MECHANICAL CODE, '15 INTERNATIONAL PLUMBING CODE, 2018 FGI GUIDELINES OUTPATIENT FACILITIES, ICC / ANSI-A117.1-2013 ADA STANDARDS, 2017 NCSEC, 2005 U.S. PUBLIC HEALTH CODE, NORTH CAROLINA ADMIN. CODE, DHSR RULES AND REGULATIONS</p> <p><b>OCCUPANCY:</b> GROUP I-2 (INSTITUTIONAL)</p> <p><b>REQUIRED SEPARATION:</b> *NO SEPARATION REQUIRED TO ADJACENT GROUP 'I' TENANTS</p> <p><b>TYPE OF CONSTRUCTION:</b> TYPE I-B</p> <p><b>CLASSIFICATION OF WORK:</b> ALTERATION - LEVEL 2</p> <table border="1"> <thead> <tr> <th></th> <th>REQUIRED</th> <th>PROVIDED</th> </tr> </thead> <tbody> <tr> <td>MIN STAIR WIDTH:</td> <td>44"</td> <td>N/A</td> </tr> <tr> <td>MAX COMMON PATH OF TRAVEL:</td> <td>75'</td> <td>36'-3"</td> </tr> <tr> <td>MAX TRAVEL DISTANCE:</td> <td>200'</td> <td>105'-6"</td> </tr> <tr> <td>MAX DEAD END:</td> <td>20'</td> <td>N/A</td> </tr> <tr> <td>NO. OF EXITS:</td> <td>2</td> <td>2</td> </tr> </tbody> </table> <p>* BUILDING IS PROVIDED WITH A FULLY AUTOMATIC SPRINKLER SYSTEM</p>				REQUIRED	PROVIDED	MIN STAIR WIDTH:	44"	N/A	MAX COMMON PATH OF TRAVEL:	75'	36'-3"	MAX TRAVEL DISTANCE:	200'	105'-6"	MAX DEAD END:	20'	N/A	NO. OF EXITS:	2	2	REV	DATE	<p><b>ARCHITECTURAL:</b></p> <p>T TITLE SHEET A010 LIFE SAFETY PLAN A210 DEMO AND FLOOR PLAN A410 DEMO AND REFLECTED CEILING PLAN A910 ICRA COORDINATION PLAN</p> <p><b>ELECTRICAL:</b></p> <p>E0.1 ELECTRICAL NOTES, LEGEND AND SCHEDULES E1.1 FIRST FLOOR ELECTRICAL PLAN E2.1 FIRST FLOOR LIGHTING PLAN E3.1 SIEMENS REFERENCE DESIGN PLANS E3.2 SIEMENS REFERENCE DESIGN PLANS</p> <p><b>MECHANICAL:</b></p> <p>M1.1 FIRST FLOOR MECHANICAL PLAN</p>
	REQUIRED	PROVIDED																									
MIN STAIR WIDTH:	44"	N/A																									
MAX COMMON PATH OF TRAVEL:	75'	36'-3"																									
MAX TRAVEL DISTANCE:	200'	105'-6"																									
MAX DEAD END:	20'	N/A																									
NO. OF EXITS:	2	2																									
<p><b>BUILDING KEY PLAN</b></p> <p>SCOPE AREA WITHIN BUILDING</p>		<p><b>LIFE SAFETY CODE</b></p> <p><b>GOVERNING CODES:</b> 2015 INTERNATIONAL FIRE CODE NCBC - FPC NFPA 101 LIFE SAFETY CODE - 2012 ED. NFPA 13 LIFE SAFETY CODE - STANDARD FOR THE INSTALLATION OF SPRINKLER SYSTEMS 2013 ED.</p> <p><b>OCCUPANCY:</b> (INSTITUTIONAL)</p> <table border="1"> <thead> <tr> <th></th> <th>REQUIRED</th> <th>PROVIDED</th> </tr> </thead> <tbody> <tr> <td>MAX COMMON PATH OF TRAVEL:</td> <td>75'</td> <td>36'-3"</td> </tr> <tr> <td>MAX TRAVEL DISTANCE:</td> <td>200'</td> <td>105'-6"</td> </tr> <tr> <td>MAX DEAD END:</td> <td>20'</td> <td>N/A</td> </tr> </tbody> </table> <p>* BUILDING IS PROVIDED WITH A FULLY AUTOMATIC SPRINKLER SYSTEM</p>				REQUIRED	PROVIDED	MAX COMMON PATH OF TRAVEL:	75'	36'-3"	MAX TRAVEL DISTANCE:	200'	105'-6"	MAX DEAD END:	20'	N/A											
	REQUIRED	PROVIDED																									
MAX COMMON PATH OF TRAVEL:	75'	36'-3"																									
MAX TRAVEL DISTANCE:	200'	105'-6"																									
MAX DEAD END:	20'	N/A																									

revision:

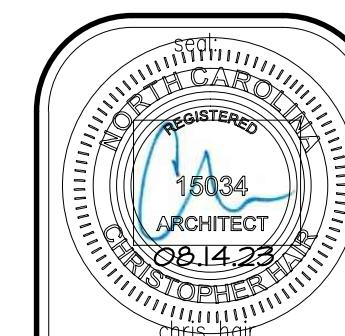

An Interior Renovation for:  
**Harnett Health  
 RAD Room 1318 Renovation**  
 215 Brighwater Drive  
 Lillington, North Carolina

job no. 23-016  
 principal: CHRIS HAIR  
 CH  
 file name:  
 date: 08.10.23  
 title: LIFE SAFETY PLAN

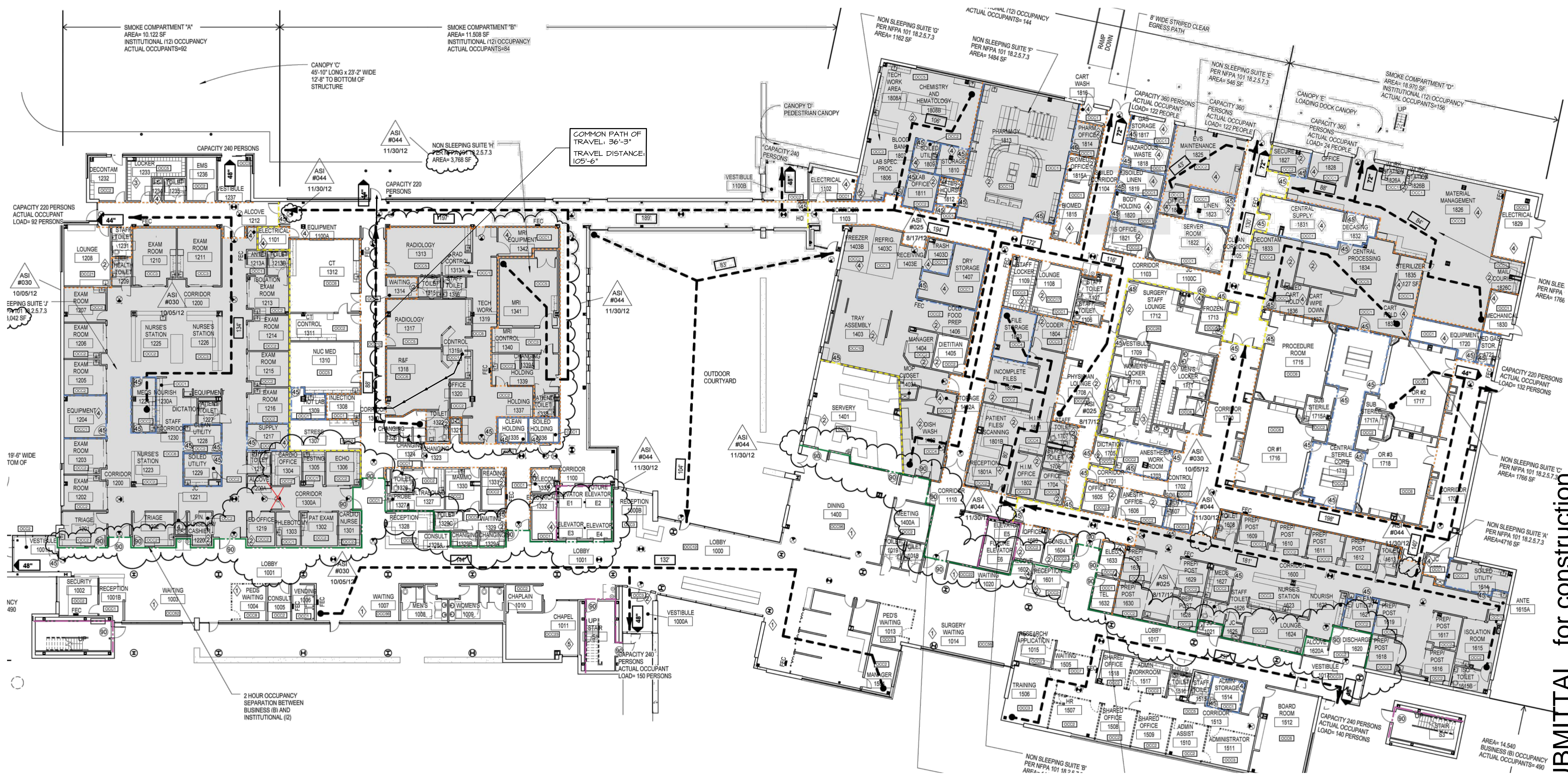
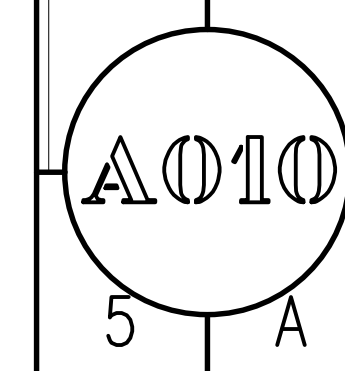

**FINAL SUBMITTAL for construction**



FINISH SCHEDULE						REMARKS
ROOM #	DESCR.	FLOOR	WALLS	BASE	CEILING	
1310	EXAM ROOM	SV-1	PT-1	CB-1	AC-1	
1310A	CONTROL	SV-1	PT-1	CB-1	EX	
1322	RESTROOM	SV-1	PT-1	CB-1	EX	
<b>ABBREV.</b> UNO = UNLESS OTHERWISE NOTED, MS = MANUFACTURER STANDARD, EX = EXISTING, EXP = EXPOSED ALL FINISHES TO BE VERIFIED BY OWNER PRIOR TO PURCHASE AND INSTALL. <b>NOTES</b>						

MANUFACTURER SPECIFICATIONS			
DESCR.	MANUF.	MODEL	REMARKS
SHEET VINYL (SV-1)	ME	ME	MATCH EXISTING ADJACENT
COVE BASE (CB-1)	ME	ME	4" INTEGRAL FLASH COVE BASE
PAINT (PT-1)	ME	LATEX PAINT	MATCH EXISTING ADJACENT
PAINT (PT-2)	ME	LATEX PAINT	MATCH EXISTING ADJACENT
<b>ABBREV.</b> UNO = UNLESS OTHERWISE NOTED, MS = MANUFACTURER STANDARD, EX = EXISTING, EXP = EXPOSED, ME = MATCH EXISTING ALL FINISHES TO BE VERIFIED BY OWNER PRIOR TO PURCHASE AND INSTALL. <b>NOTES</b>			

**DEMOLITION NOTES:**

- ITEMS SCHEDULED TO BE DEMOLISHED SHALL BE REMOVED IN THEIR ENTIRETY, INCLUDING INSTALLATIONS ABOVE THE CEILING. EXISTING WALLS SHALL BE PATCHED WHERE ITEMS WERE REMOVED TO MATCH ADJACENT SURFACES.
- DUST BARRIERS SHALL BE CONSTRUCTED AND MAINTAINED THROUGH THE COURSE OF CONSTRUCTION TO MINIMIZE THE SPREAD OF CONSTRUCTION DUST.
- PROTECT EXISTING WALLS TO REMAIN. ALL EXISTING WALLS TO REMAIN TO BE FINISHED TO ACHIEVE 'AS NEW' APPEARANCE.
- CONTRACTOR TO PROTECT OR REMOVE CEILING TILE AS REQUIRED IN AREAS WHERE EQUIPMENT IS BEING INSTALLED.
- PATCH EXISTING CEILINGS AS REQUIRED DUE TO INSTALLATION OF OVERHEAD EQUIPMENT.
- REMOVE EXISTING LIGHTING AS SCHEDULED. EXISTING FIRE SPRINKLER HEADS TO BE LEFT INTACT.

**SYMBOL LEGEND:**

- EXISTING WALL TO REMAIN
- EXISTING WINDOW TO REMAIN
- EXISTING DOOR TO REMAIN

**PLAN NOTES:**

- CONTRACTORS TO VERIFY ALL FIELD CONDITIONS PRIOR TO COMMENCEMENT AND REPORT ANY DISCREPANCIES TO THE ARCHITECT
- ALL PENETRATIONS, NEW AND EXISTING THROUGH RATED PARTITIONS MUST MEET UL APPROVED STANDARDS - SUBMIT SYSTEM TO ARCHITECT FOR APPROVAL. FIELD VERIFY PRIOR TO BID.
- PROVIDE SOLID WOOD BACKING FOR ALL WALLS TO RECEIVE COUNTERS, CABINETS, DOOR STOPS, SINKS, TOILET ACCESSORIES, CHAIR RAILS, AND OTHER RELATED INSTALLATIONS. THE INSTALLATIONS SHALL BE INSPECTED BY THE ARCHITECT PRIOR TO COVERING WITH DRYWALL.
- THE NOTE HOLD ON DIMENSION STRINGS INDICATE MINIMUM CLEAR FINISH DIMENSIONS.
- PENETRATIONS THROUGH FIRE RATED PARTITIONS WILL BE FIRE CAULKED WITH THE UL SYSTEM NO. W-L-1044.

**FINISH NOTES:**

- ALL FINISHES SHALL MEET THE REQUIREMENTS OF NCBC 2010 CHAPTER 8, TABLE 803.11:
  - VERTICAL EXITS AND EXIT PASSAGEWAYS - CLASS B
  - EXIT ACCESS CORRIDORS AND OTHER EXIT WAYS - CLASS C
  - ROOMS AND ENCLOSED SPACES - CLASS C
- ALL FINISHES TO BE APPROVED BY TENANT PRIOR TO INSTALLATION.
- PROVIDE APPROPRIATE HANDICAP ACCESSIBLE THRESHOLDS WHERE FLOOR CHANGES MATERIAL.
- SEE FINISH SCHEDULE FOR PLASTIC LAMINATE COLORS.
- ALL EXISTING DRYWALL WALLS WITHIN THE SCOPE AREA SHALL BE PAINTED W/ TWO COATS FLAT FINISH LATEX PAINT AS REQUIRED TO COVER. ALL WALLS SHALL THEN BE PAINTED WITH ONE COLOR, ONE COAT, SEE FINISH SCHEDULE FOR COLORS.
- THE EXISTING DOORS SHALL BE REFINISHED TO MATCH THE EXISTING ADJACENT.
- PROVIDE MINIMUM CLASS II FLOOR FINISH MATERIALS TO COMPLY WITH MINIMUM CRITICAL RADIANT FLUX IN EXIT PASSAGEWAYS AND CORRIDORS. ALL OTHER AREAS MUST COMPLY WITH THE DOC FF-1 'PULL-TEST' (FPC 16 CFR, PART 1630)
- PAINT NEW EXPOSED ELECTRICAL CABLE DUCTING AND CONDUIT, COLOR TO MATCH WALLS.
- PAINT DOOR AND WINDOW FRAMES WITH TWO COATS SEMI GLOSS LATEX PAINT.

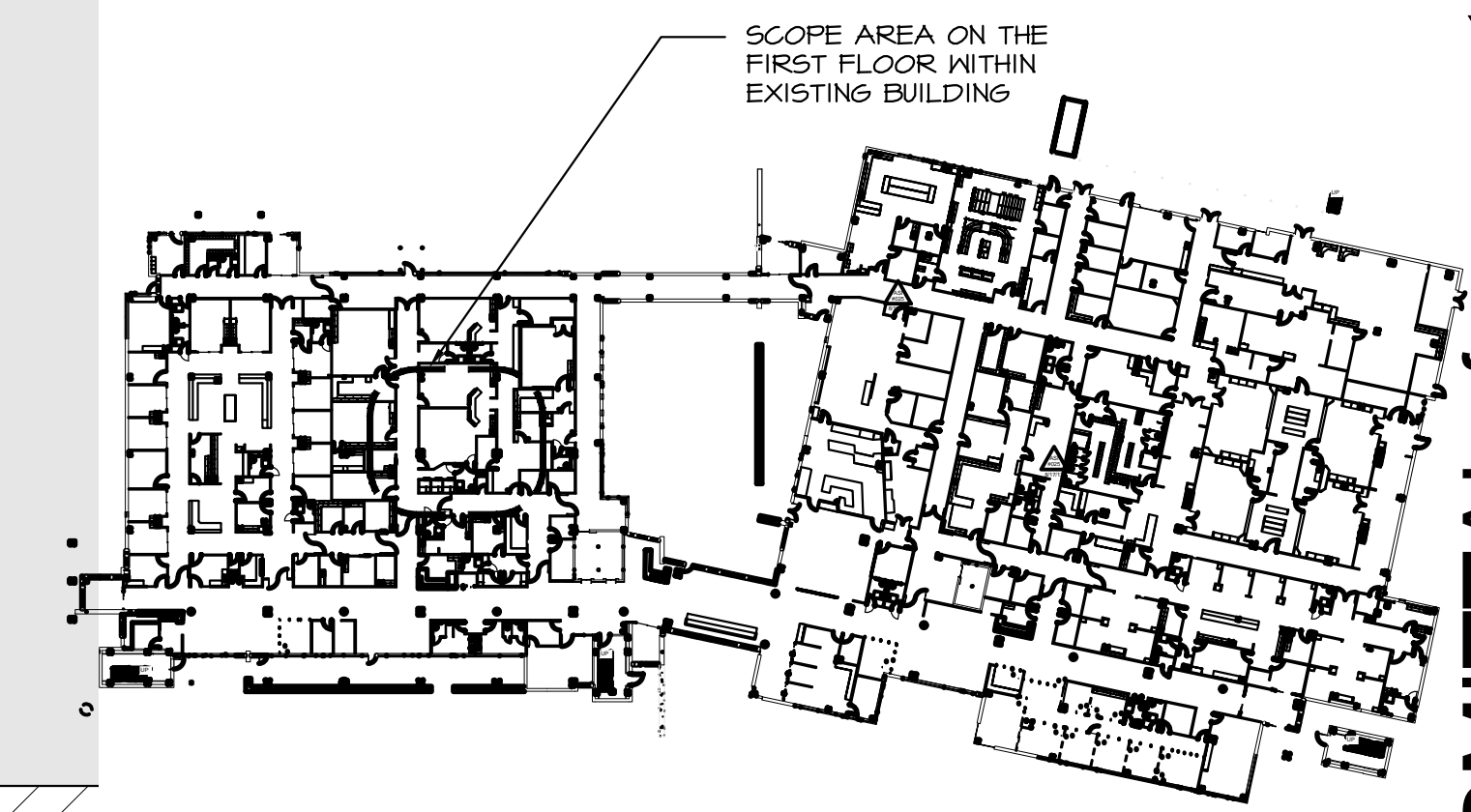
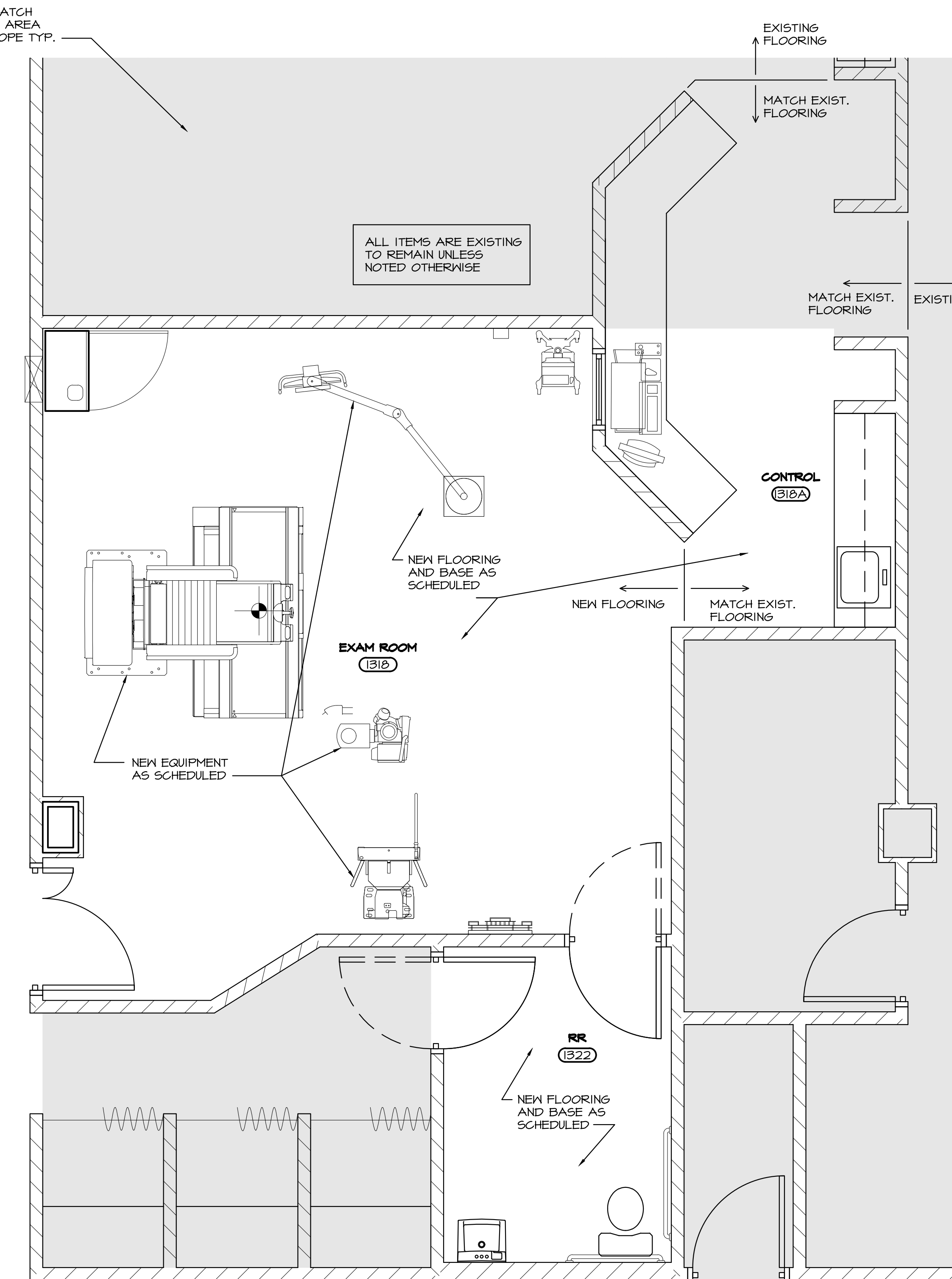
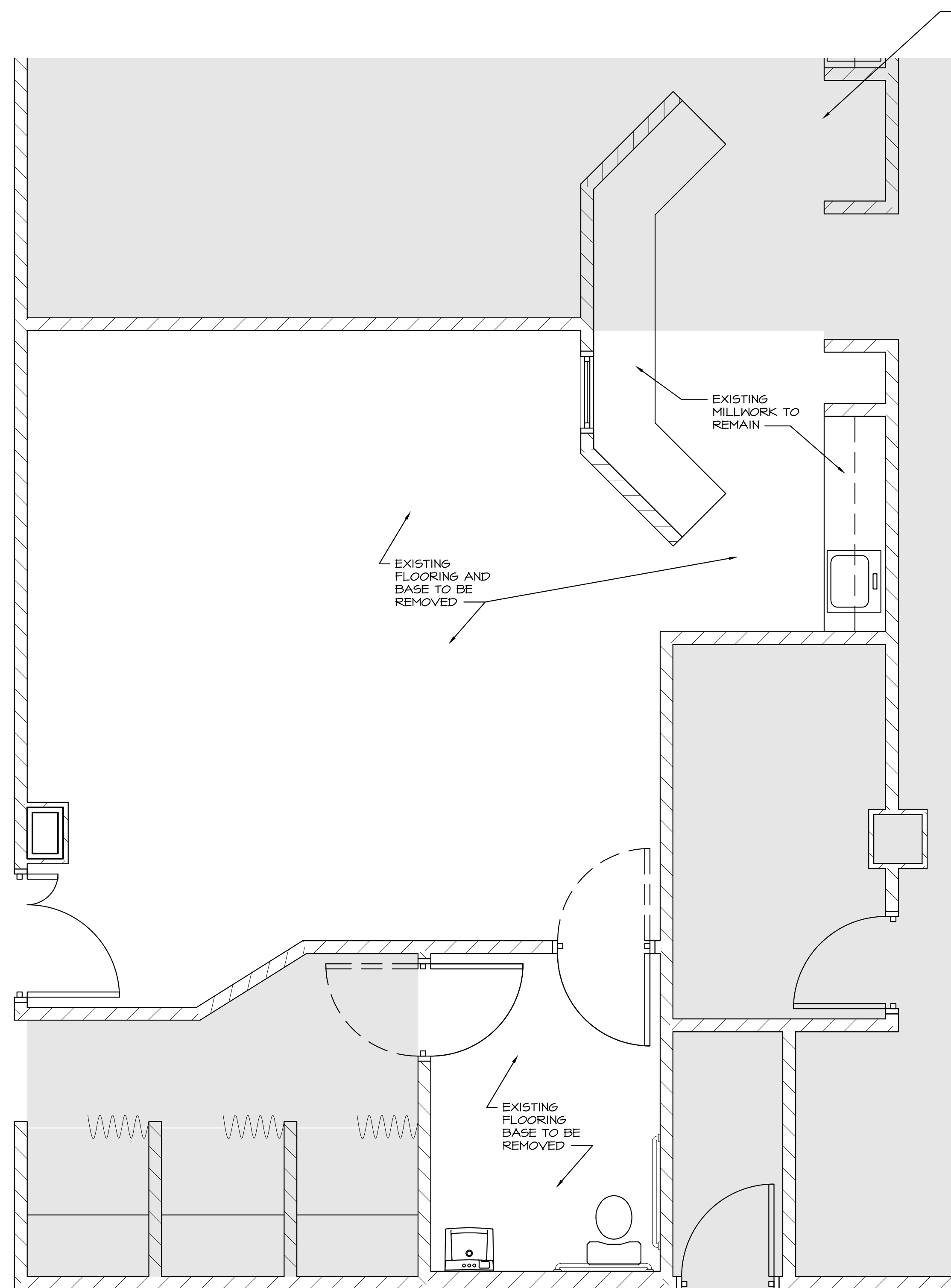

**DEMOLITION PLAN**  
3/8"=1'-0"

**FIRST FLOOR PLAN**  
3/8"=1'-0"

**OVERALL FIRST FLOOR PLAN**  
NTS

**C.D. HAIR ARCHITECT**  
8401 Lake Worth Road  
Suite 119  
Lake Worth, FL  
15034

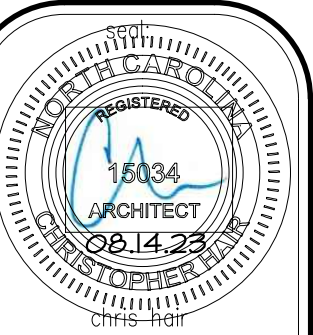





An Interior Renovation for:  
**Harnett Health  
RAD Room 1318 Renovation**  
215 Brighthwater Drive  
Lillington, North Carolina

**FINAL SUBMITTAL for construction**



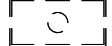

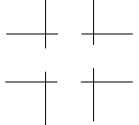
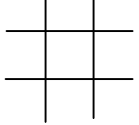
job no. 23-016  
principal: CHRIS HAIR  
CH  
file name:  
date: 08.10.23  
title: DEMO AND FLOOR PLAN

**A210**  
5 A

**CEILING DEMOLITION LEGEND:**

-  EXISTING LIGHT FIXTURE TO BE REMOVED
-  EXISTING LIGHT FIXTURE TO BE SALVAGED FOR REINSTALLATION
-  EXISTING SUPPLY REGISTER TO BE SALVAGED FOR REINSTALLATION
-  EXISTING RETURN REGISTER TO BE SALVAGED FOR REINSTALLATION
-  EXISTING ACOUSTICAL CEILING AND GRID TO BE REMOVED
-  EXISTING CEILING AND INSTALLATIONS TO REMAIN
-  EXISTING FIRE SPRINKLER HEAD TO BE SALVAGED FOR REINSTALLATION

**CEILING LEGEND:**

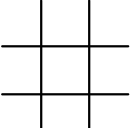
-  EXISTING REINSTALLED 2' x 4' LED LIGHT FIXTURE
  -  NEW 6" RECESSED DIMMABLE LED CAN LIGHT FIXTURE
  -  EXISTING REINSTALLED SUPPLY REGISTER
  -  EXISTING REINSTALLED RETURN REGISTER
  -  EXISTING REINSTALLED FIRE SPRINKLER HEAD
  -  NEW 2 X 2 CEILING IN NEW GRID - PROVIDE TILE AS SPECIFIED
- D = DIMMABLE

**CEILING NOTES:**

1. ALL CEILING MOUNTED ITEMS, INCLUDING LIGHTS, AND HVAC REGISTERS, SHALL BE CENTERED IN THE TILE. ANY CONFLICTS SHALL BE REPORTED TO THE ARCHITECT UPON DISCOVERY. UNDER NO CIRCUMSTANCES SHALL ANY ITEM BE RELOCATED WITHOUT THE ARCHITECT'S APPROVAL.
2. ALL RECTANGULAR ROOMS SHALL HAVE EQUAL BORDERS UNLESS NOTED OTHERWISE. SEE THE PLANS FOR DENOTED STARTING POINTS AND POINTS OF ALIGNMENT.
3. ALL CEILING HEIGHTS FOR SUSPENDED CEILINGS ARE INDICATED ON THE CEILING PLAN.
4. ALL NEW CEILING GRID SHALL BE ATTACHED TO THE ROOF / FLOOR JOISTS ABOVE AT 4'-0" O.C. (MAX) WITH ASTM A641, CLASS 1 ZINC COATED, SOFT TEMPER, PRE-STRETCHED HANGER WIRE (12 GA) MINIMUM. ALL HANGER WIRE SHALL BE INSTALLED PLUMB AND STRAIGHT. GRID SUSPENSION SYSTEM TO MEET ASTM 635-636.

**C.D. HAIR ARCHITECT**  
 8401 Lake Worth Road  
 Suite 119  
 Lake Worth, FL  
**15034**

revision:

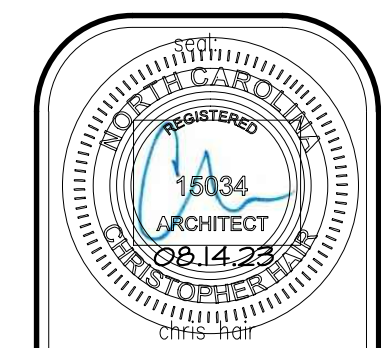



An Interior Renovation for:  
**Harnett Health**  
**RAD Room 1318 Renovation**  
 215 Brighthwater Drive  
 Lillington, North Carolina

FINAL SUBMITTAL for construction

job no. **23-016**  
 principal: **CHRIS HAIR**  
 CH  
 file name:  
 date: **08.10.23**  
 title: **DEMO AND REFLECTED CEILING PLAN**

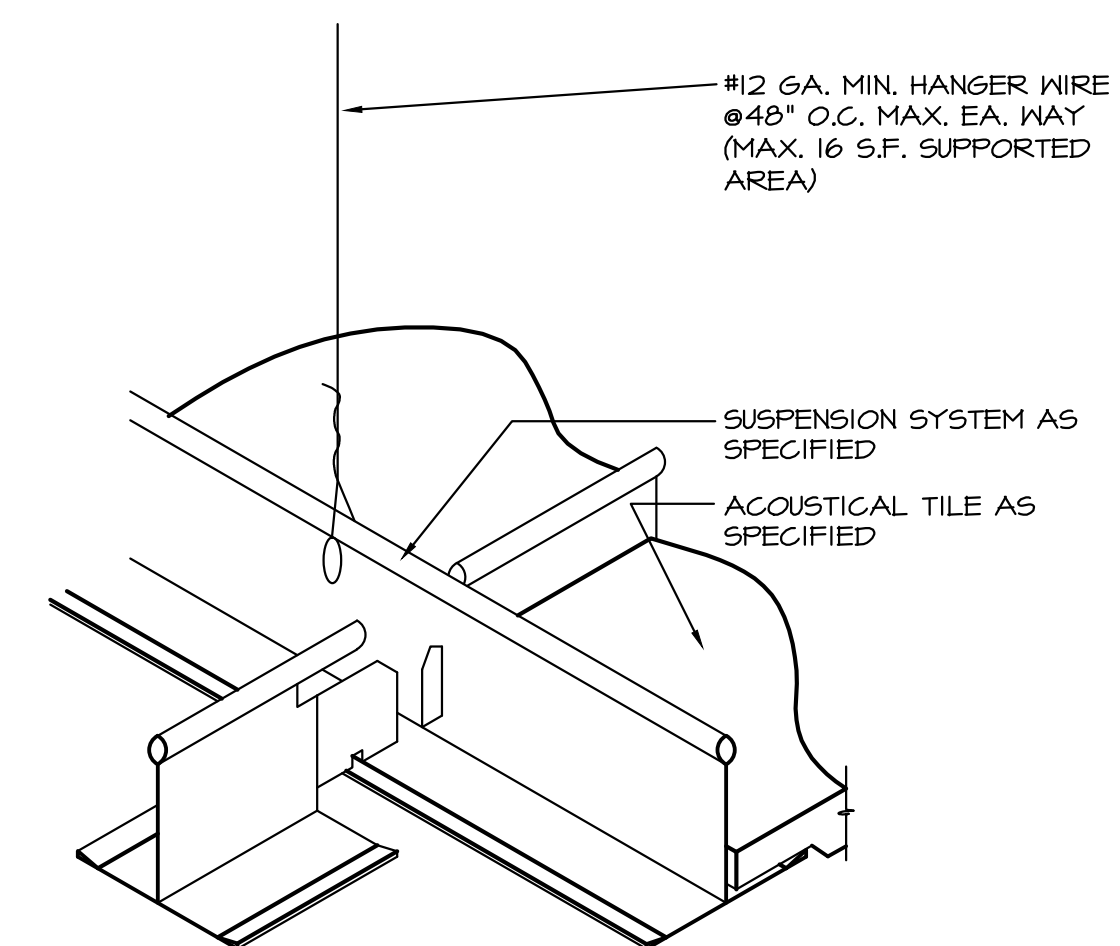
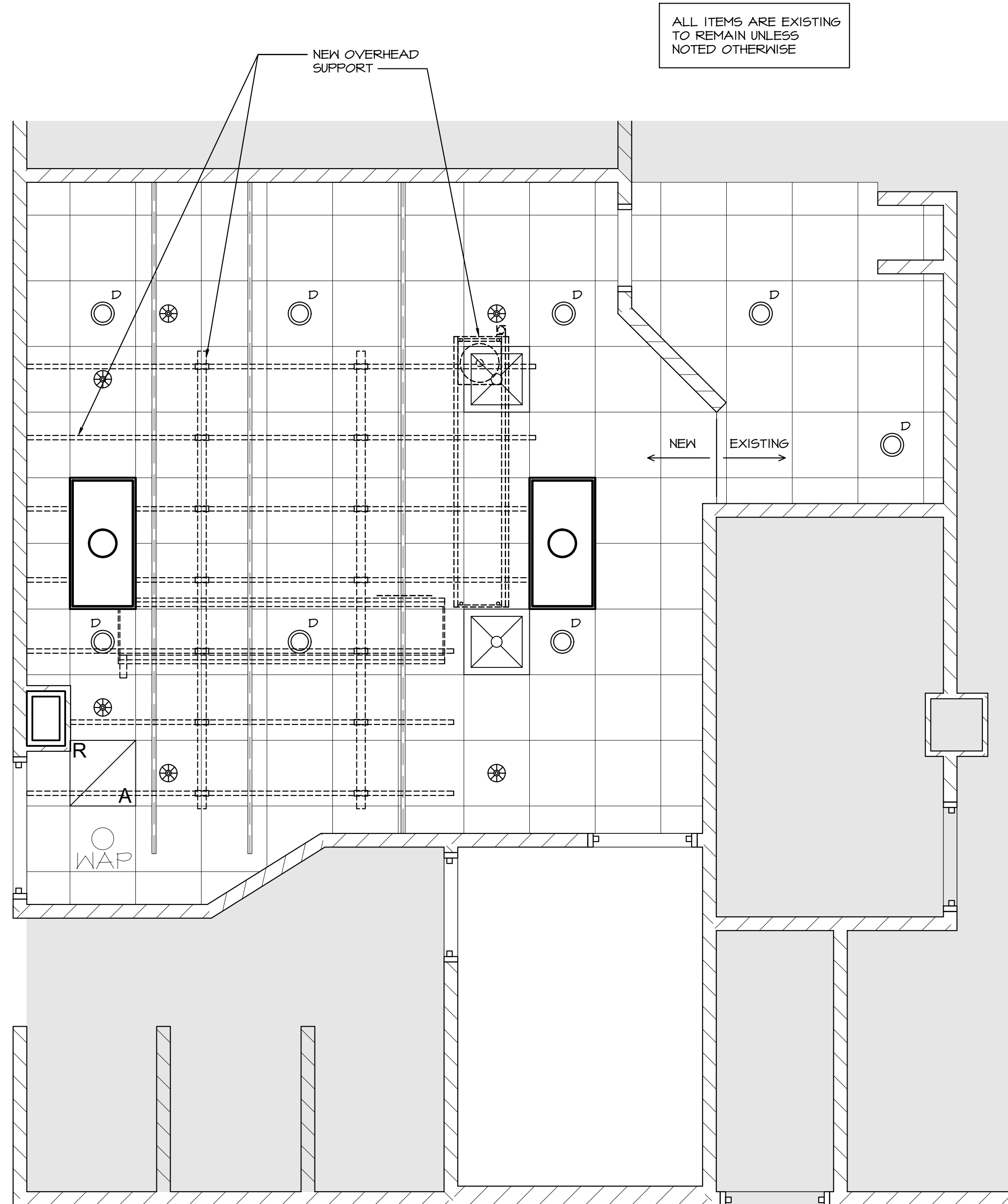
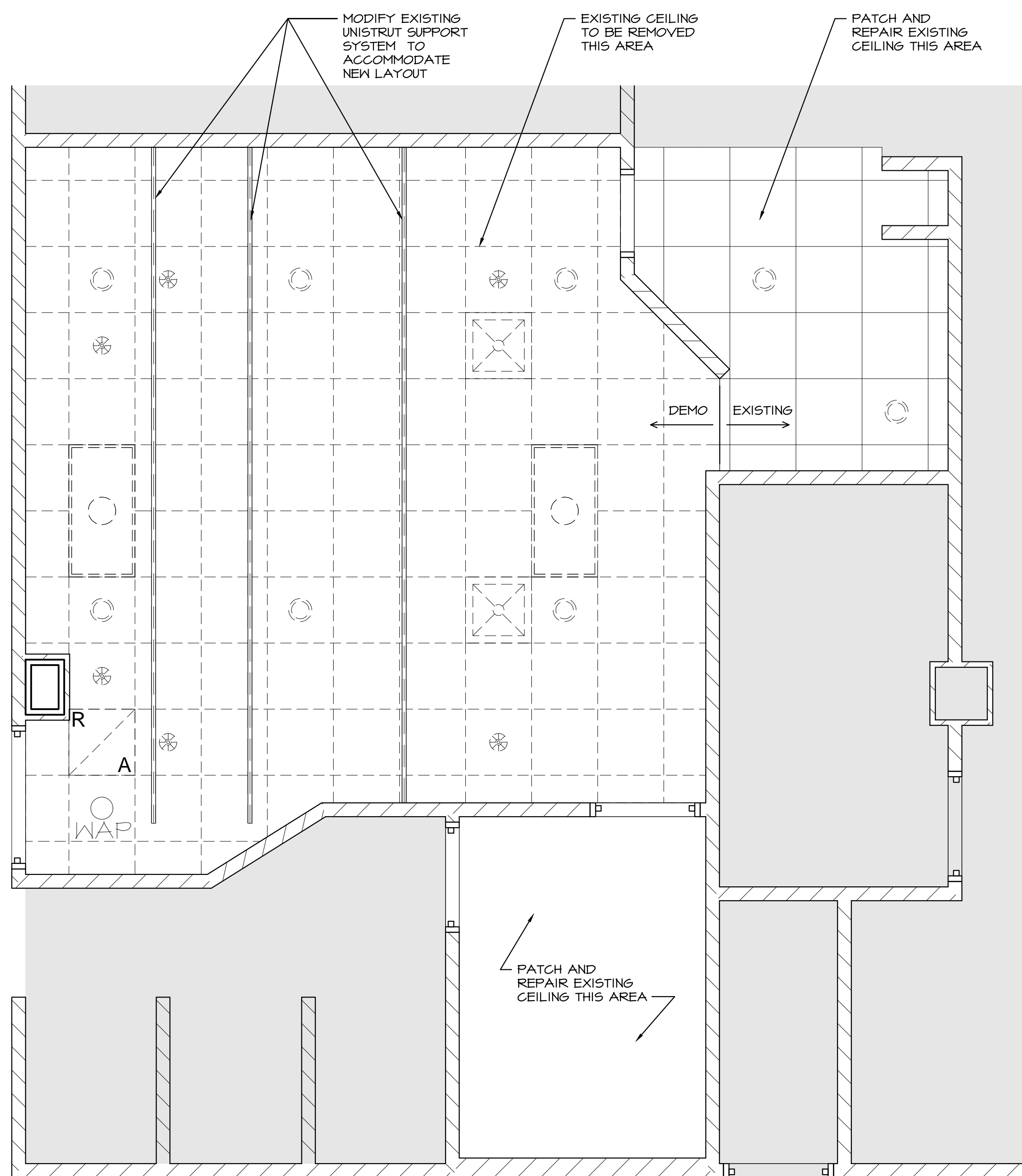
**A410**  
 5 A



**DEMOLITION CEILING PLAN**  
 3/8" = 1'-0"

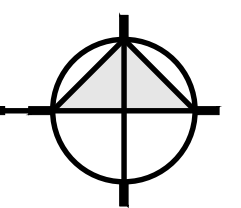

**REFLECTED CEILING PLAN**  
 3/8" = 1'-0"

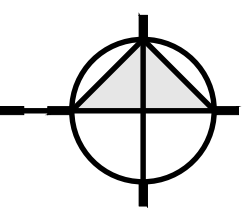

**CEILING GRID DETAIL**  
 3" = 1'-0"

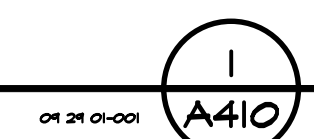

FINAL SUBMITTAL for construction

revision:

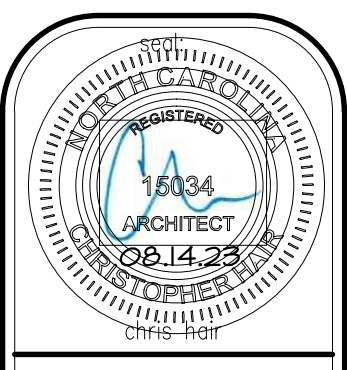
An Interior Renovation for:  
**Hennett Health  
 RAD Room 1318 Renovation**  
 215 Brighthelm Drive  
 Lillington, North Carolina

FINAL SUBMITTAL for construction

job no. 23-016  
 principal: CHRIS HAIR  
 CH  
 file name:  
 date: 08.10.23  
 title: ICRA COORDINATION PLAN

**ICRA PLAN NOTES**

1. THE GENERAL CONTRACTOR SHALL BECOME FAMILIAR WITH THE PROJECT SITE AND NOTIFY THE ARCHITECT IMMEDIATELY OF DISCREPANCIES.

**PLAN KEYNOTES**

1. PRIOR TO CONSTRUCTION, SEAL OFF APPLICABLE SITE SUPPLY AND RETURN AIR DIFFUSERS AND GRILLES TO MINIMIZE DUST CONTAMINATION OF DUCTWORK AND SURROUNDING AREAS. PROVIDE NEGATIVE PRESSURE WITHIN THE PROJECT AREA RELATIVE TO THE AREAS SURROUNDING THE PROJECT AREA AS WELL AS HEPA AIR FILTRATION. PROVIDE MEANS OF MONITORING THE AIR PRESSURE FOR THE ENTIRE DURATION OF CONSTRUCTION.
2. SEAL EXISTING AREA WITH FIRE RETARDANT VISQUEEN ABOVE THE CEILING. TAPE PERIMETER SUCH THAT AN AIR TIGHT BARRIER IS ACHIEVED.
3. PROVIDE WALK-OFF MAT
4. PROVIDE TEMPORARY ZIPWALL CONTAINMENT BARRIER

**ICRA CLASSIFICATION DATA**

CONSTRUCTION TYPE: I-B  
 CONSTRUCTION CLASS: II  
 RISK CLASS: MEDIUM

CONSTRUCTION PROTOCOLS

DURING CONSTRUCTION	UPON COMPLETION
1. SEAL SITE SUPPLY AND RETURN AIR DIFFUSERS.	1. DO NOT REMOVE BARRIERS FROM WORK AREA UNTIL COMPLETED PROJECT IS INSPECTED BY THE OWNERS SAFETY DEPARTMENT AND INFECTION CONTROL DEPARTMENT AND THOROUGHLY CLEANED BY THE OWNERS ENVIRONMENTAL SERVICES DEPARTMENT.
2. INSTALL TEMPORARY ZIPWALL BARRIER AS SHOWN ON DETAIL 1, THIS SHEET.	2. REMOVE BARRIER MATERIALS CAREFULLY TO MINIMIZE SPREADING OF DIRT AND DEBRIS ASSOCIATED WITH CONSTRUCTION.
3. PROVIDE A TEMPORARY NEGATIVE AIR UNIT WITH HEPA FILTRATION TO PLACE PROJECT SITE AT NEGATIVE PRESSURE.	3. VACUUM WORK AREA WITH HEPA FILTERED VACUUMS.
4. PROVIDE SHOE COVERS AND TEMPORARY WALK OFF ADHESIVE MATS AT EXIT OF PROJECT AREA.	4. WET MOP AREA WITH DISINFECTANT.
5. CONTAIN CONSTRUCTION WASTE BEFORE TRANSPORT IN TIGHTLY COVERED CONTAINERS.	5. REMOVE ISOLATION OF HVAC SYSTEM IN AREAS WHERE WORK IS BEING PERFORMED.

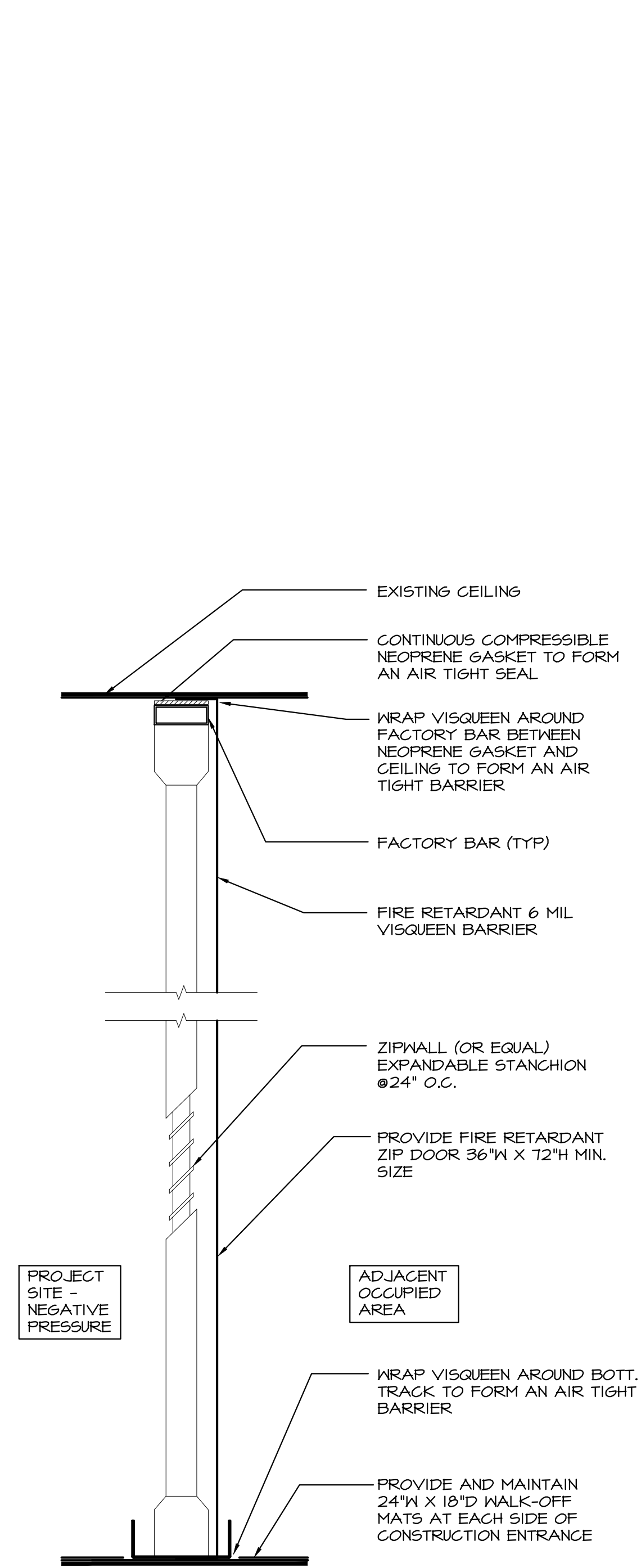

**TEMPORARY ZIPWALL CONTAINMENT BARRIER**  
 3" = 1'-0" 01/24/01-001 A910

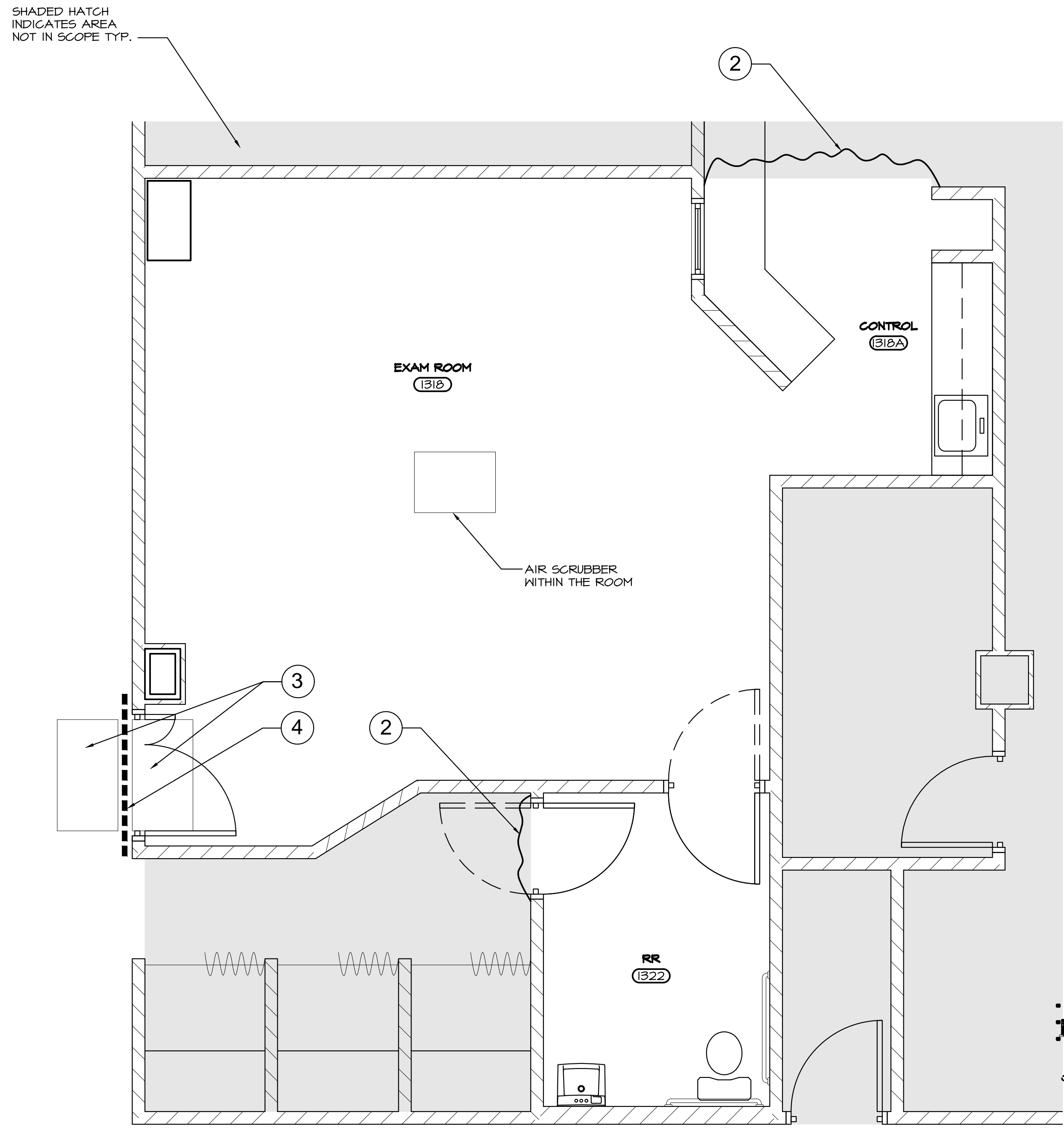

**ICRA COORDINATION PLAN**  
 3/8" = 1'-0"

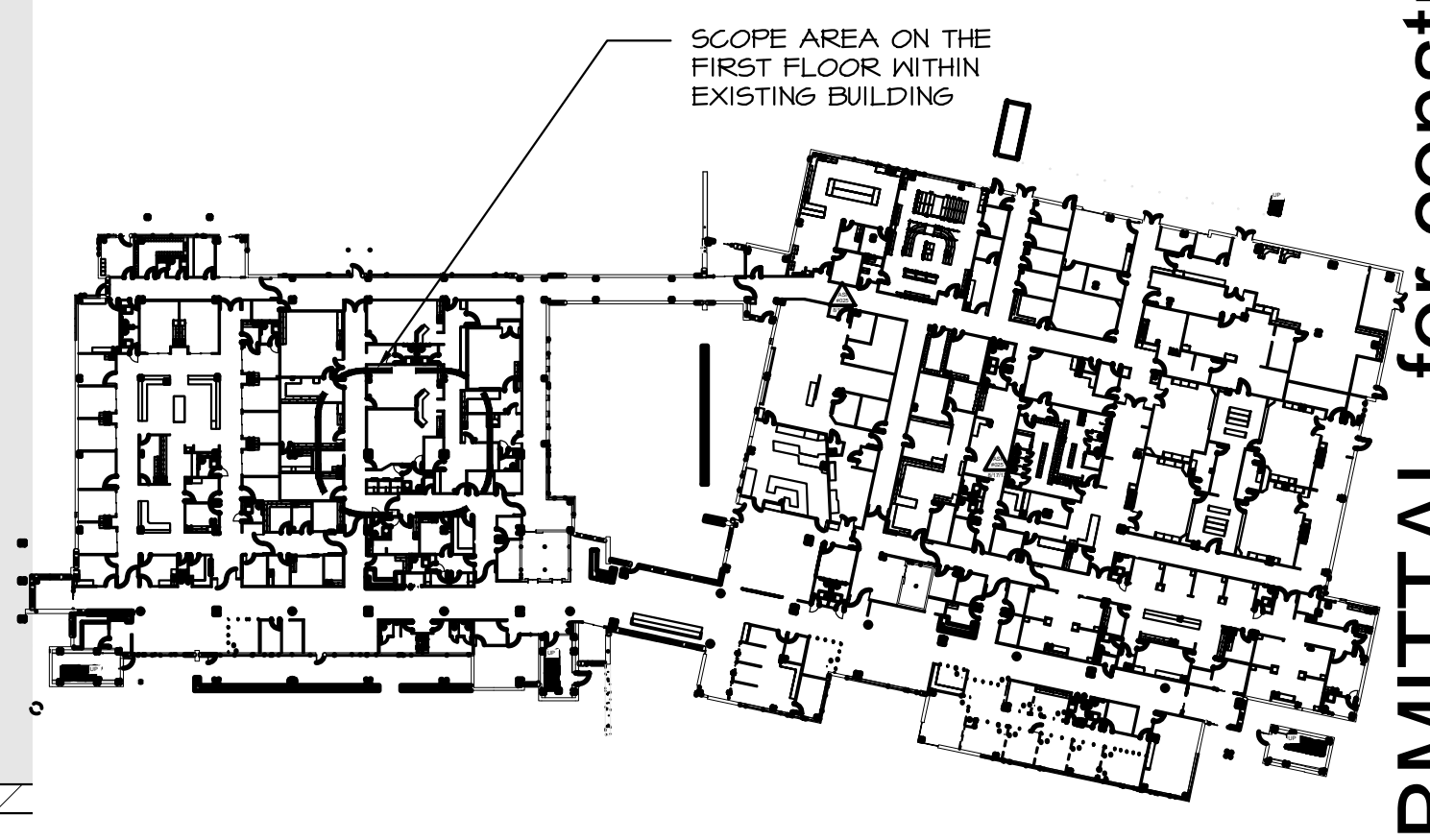

**OVERALL FIRST FLOOR PLAN**  
 NTS

FINAL SUBMITTAL for construction

# HARNETT HEALTH RAD ROOM 1318

an Interior Renovation for:

215 Brightwater Drive  
Lillington, North Carolina

**ARCHITECT**  
C.D. HAIR ARCHITECT L.L.C.  
8401 LAKE WORTH ROAD, SUITE 119  
LAKE WORTH, FLORIDA 33461  
(561) 209.6050  
chris@cdhairarchitect.com

**MECHANICAL ELECTRICAL**  
THOMPSON YOUNGROSS ENGINEERING CONSULTANTS  
902 CLINT MOORE ROAD, SUITE 142  
BOCA RATON, FLORIDA 33461  
(561) 274.0200  
artur@tecfla.com (Artur Amarel)

**GENERAL CONTRACTOR**  
BLAKE CONTRACTING  
1994 REMOUNT ROAD  
GASTONIA, NORTH CAROLINA 28054  
(704) 868.9930  
blake@blakegc.com (Blake Skarpalezos)



C.D. HAIR ARCHITECT  
8401 Lake Worth Road  
Suite 119  
Lake Worth, FL  
15034

revision:

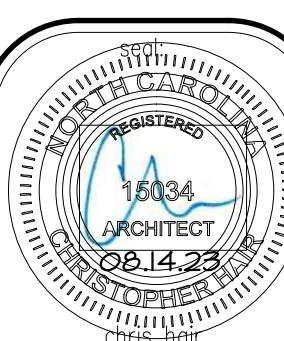

An Interior Renovation for:  
**Harnett Health  
RAD Room 1318 Renovation**  
215 Brightwater Drive  
Lillington, North Carolina

job no. 23-016  
principal: CHRIS HAIR  
CH

file name:

date: 08.10.23  
title:

TITLE SHEET

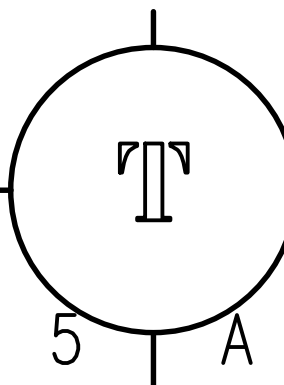

FINAL SUBMITTAL for construction

PROJECT SCOPE		PROJECT DATA		PROJECT CODE TABULAR			SHEET INDEX																				
<p>THE PROJECT INVOLVES AN EQUIPMENT CHANGE-OUT WITHIN AN EXISTING ROOM ON THE FIRST FLOOR WITHIN AN EXISTING IN-PATIENT, HOSPITAL. THE NEWLY RENOVATED SPACE WILL BE USED AS A RAD ROOM. (NO CHANGE TO THE EXISTING FUNCTION OF THE ROOM), NO NEW WALLS, DOORS OR OTHER LAYOUT CHANGES ARE IN THIS SCOPE OF THE RAD ROOM WORK. THE EXISTING FLOOR FINISHES SHALL BE REPLACED, THE EXISTING MILLWORK WILL REMAIN. THE EXISTING LIGHTING SHALL BE REPLACED. THE EXISTING HVAC SHALL REMAIN. THE BUILDING IS MULTI STORY AND ASSUMED TO BE TYPE I-B. THE SCOPE AREA IS PROTECTED BY A FULLY AUTOMATIC FIRE-SPRINKLER SYSTEM.</p> <p>DHSR PROJECT NO.: HL-12893</p> <p><b>VICINITY SKETCH</b> NOT TO SCALE</p>		<p><b>AREA CALCULATIONS:</b></p> <p>SCOPE AREA WITHIN EXIST. HOSPITAL 574 SF</p> <p><b>OCCUPANCY LOAD CALCULATIONS:</b></p> <p>INSTITUTIONAL I-2 574 S.F. / 240 GROSS = 2.39 (3 PEOPLE)</p>		<p><b>MUNICIPALITY:</b> HARNETT COUNTY</p> <p><b>GOVERNING CODES:</b> 2018 NORTH CAROLINA STATE BUILDING CODE BASED ON IBC - 2015 INTERNATIONAL BUILDING CODE W, AMENDMENTS IEBC - 2015 INTERNATIONAL EXISTING BUILDING CODE, '15 INTERNATIONAL FUEL GAS CODE, '15 INTERNATIONAL MECHANICAL CODE, '15 INTERNATIONAL PLUMBING CODE, 2018 FGI GUIDELINES OUTPATIENT FACILITIES, ICC / ANSI-A117.1-2013 ADA STANDARDS, 2017 NCSEC, 2005 U.S. PUBLIC HEALTH CODE, NORTH CAROLINA ADMIN. CODE, DHSR RULES AND REGULATIONS</p> <p><b>OCCUPANCY:</b> GROUP I-2 (INSTITUTIONAL)</p> <p><b>REQUIRED SEPARATION:</b> *NO SEPARATION REQUIRED TO ADJACENT GROUP 'I' TENANTS</p> <p><b>TYPE OF CONSTRUCTION:</b> TYPE I-B</p> <p><b>CLASSIFICATION OF WORK:</b> ALTERATION - LEVEL 2</p> <table border="1"> <thead> <tr> <th></th> <th>REQUIRED</th> <th>PROVIDED</th> </tr> </thead> <tbody> <tr> <td>MIN STAIR WIDTH:</td> <td>44"</td> <td>N/A</td> </tr> <tr> <td>MAX COMMON PATH OF TRAVEL:</td> <td>75'</td> <td>36'-3"</td> </tr> <tr> <td>MAX TRAVEL DISTANCE:</td> <td>200'</td> <td>105'-6"</td> </tr> <tr> <td>MAX DEAD END:</td> <td>20'</td> <td>N/A</td> </tr> <tr> <td>NO. OF EXITS:</td> <td>2</td> <td>2</td> </tr> </tbody> </table> <p>* BUILDING IS PROVIDED WITH A FULLY AUTOMATIC SPRINKLER SYSTEM</p>				REQUIRED	PROVIDED	MIN STAIR WIDTH:	44"	N/A	MAX COMMON PATH OF TRAVEL:	75'	36'-3"	MAX TRAVEL DISTANCE:	200'	105'-6"	MAX DEAD END:	20'	N/A	NO. OF EXITS:	2	2	REV	DATE	<p><b>ARCHITECTURAL:</b></p> <p>T TITLE SHEET A010 LIFE SAFETY PLAN A210 DEMO AND FLOOR PLAN A410 DEMO AND REFLECTED CEILING PLAN A910 ICRA COORDINATION PLAN</p> <p><b>ELECTRICAL:</b></p> <p>E0.1 ELECTRICAL NOTES, LEGEND AND SCHEDULES E1.1 FIRST FLOOR ELECTRICAL PLAN E2.1 FIRST FLOOR LIGHTING PLAN E3.1 SIEMENS REFERENCE DESIGN PLANS E3.2 SIEMENS REFERENCE DESIGN PLANS</p> <p><b>MECHANICAL:</b></p> <p>M1.1 FIRST FLOOR MECHANICAL PLAN</p>
	REQUIRED	PROVIDED																									
MIN STAIR WIDTH:	44"	N/A																									
MAX COMMON PATH OF TRAVEL:	75'	36'-3"																									
MAX TRAVEL DISTANCE:	200'	105'-6"																									
MAX DEAD END:	20'	N/A																									
NO. OF EXITS:	2	2																									
<b>BUILDING KEY PLAN</b>		<b>LIFE SAFETY CODE</b>																									
<p>SCOPE AREA WITHIN BUILDING</p>		<p><b>GOVERNING CODES:</b> 2015 INTERNATIONAL FIRE CODE NCBC - FPC NFPA 101 LIFE SAFETY CODE - 2012 ED. NFPA 13 LIFE SAFETY CODE - STANDARD FOR THE INSTALLATION OF SPRINKLER SYSTEMS 2013 ED.</p> <p><b>OCCUPANCY:</b> (INSTITUTIONAL)</p> <table border="1"> <thead> <tr> <th></th> <th>REQUIRED</th> <th>PROVIDED</th> </tr> </thead> <tbody> <tr> <td>MAX COMMON PATH OF TRAVEL:</td> <td>75'</td> <td>36'-3"</td> </tr> <tr> <td>MAX TRAVEL DISTANCE:</td> <td>200'</td> <td>105'-6"</td> </tr> <tr> <td>MAX DEAD END:</td> <td>20'</td> <td>N/A</td> </tr> </tbody> </table> <p>* BUILDING IS PROVIDED WITH A FULLY AUTOMATIC SPRINKLER SYSTEM</p>				REQUIRED	PROVIDED	MAX COMMON PATH OF TRAVEL:	75'	36'-3"	MAX TRAVEL DISTANCE:	200'	105'-6"	MAX DEAD END:	20'	N/A											
	REQUIRED	PROVIDED																									
MAX COMMON PATH OF TRAVEL:	75'	36'-3"																									
MAX TRAVEL DISTANCE:	200'	105'-6"																									
MAX DEAD END:	20'	N/A																									





FINISH SCHEDULE						REMARKS
ROOM #	DESCR.	FLOOR	WALLS	BASE	CEILING	
1310	EXAM ROOM	SV-1	PT-1	CB-1	AC-1	
1310A	CONTROL	SV-1	PT-1	CB-1	EX	
1322	RESTROOM	SV-1	PT-1	CB-1	EX	
<b>ABBREV.</b> UNO = UNLESS OTHERWISE NOTED, MS = MANUFACTURER STANDARD, EX = EXISTING, EXP = EXPOSED <b>NOTES</b> ALL FINISHES TO BE VERIFIED BY OWNER PRIOR TO PURCHASE AND INSTALL.						

MANUFACTURER SPECIFICATIONS			
DESCR.	MANUF.	MODEL	REMARKS
SHEET VINYL (SV-1)	ME	ME	MATCH EXISTING ADJACENT
COVE BASE (CB-1)	ME	ME	4" INTEGRAL FLASH COVE BASE
PAINT (PT-1)	ME	LATEX PAINT	MATCH EXISTING ADJACENT
PAINT (PT-2)	ME	LATEX PAINT	MATCH EXISTING ADJACENT
<b>ABBREV.</b> UNO = UNLESS OTHERWISE NOTED, MS = MANUFACTURER STANDARD, EX = EXISTING, EXP = EXPOSED, ME = MATCH EXISTING <b>NOTES</b> ALL FINISHES TO BE VERIFIED BY OWNER PRIOR TO PURCHASE AND INSTALL.			

**DEMOLITION NOTES:**

- ITEMS SCHEDULED TO BE DEMOLISHED SHALL BE REMOVED IN THEIR ENTIRETY, INCLUDING INSTALLATIONS ABOVE THE CEILING. EXISTING WALLS SHALL BE PATCHED WHERE ITEMS WERE REMOVED TO MATCH ADJACENT SURFACES.
- DUST BARRIERS SHALL BE CONSTRUCTED AND MAINTAINED THROUGH THE COURSE OF CONSTRUCTION TO MINIMIZE THE SPREAD OF CONSTRUCTION DUST.
- PROTECT EXISTING WALLS TO REMAIN. ALL EXISTING WALLS TO REMAIN TO BE FINISHED TO ACHIEVE 'AS NEW' APPEARANCE.
- CONTRACTOR TO PROTECT OR REMOVE CEILING TILE AS REQUIRED IN AREAS WHERE EQUIPMENT IS BEING INSTALLED.
- PATCH EXISTING CEILINGS AS REQUIRED DUE TO INSTALLATION OF OVERHEAD EQUIPMENT.
- REMOVE EXISTING LIGHTING AS SCHEDULED. EXISTING FIRE SPRINKLER HEADS TO BE LEFT INTACT.

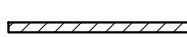
**SYMBOL LEGEND:**

-  EXISTING WALL TO REMAIN
-  EXISTING WINDOW TO REMAIN
-  EXISTING DOOR TO REMAIN

**PLAN NOTES:**

- CONTRACTORS TO VERIFY ALL FIELD CONDITIONS PRIOR TO COMMENCEMENT AND REPORT ANY DISCREPANCIES TO THE ARCHITECT
- ALL PENETRATIONS, NEW AND EXISTING THROUGH RATED PARTITIONS MUST MEET UL APPROVED STANDARDS - SUBMIT SYSTEM TO ARCHITECT FOR APPROVAL. FIELD VERIFY PRIOR TO BID.
- PROVIDE SOLID WOOD BACKING FOR ALL WALLS TO RECEIVE COUNTERS, CABINETS, DOOR STOPS, SINKS, TOILET ACCESSORIES, CHAIR RAILS, AND OTHER RELATED INSTALLATIONS. THE INSTALLATIONS SHALL BE INSPECTED BY THE ARCHITECT PRIOR TO COVERING WITH DRYWALL.
- THE NOTE HOLD ON DIMENSION STRINGS INDICATE MINIMUM CLEAR FINISH DIMENSIONS.
- PENETRATIONS THROUGH FIRE RATED PARTITIONS WILL BE FIRE CAULKED WITH THE UL SYSTEM NO. W-L-1044.

**FINISH NOTES:**

- ALL FINISHES SHALL MEET THE REQUIREMENTS OF NCBC 2010 CHAPTER 0, TABLE 003.11:
  - VERTICAL EXITS AND EXIT PASSAGEWAYS - CLASS B
  - EXIT ACCESS CORRIDORS AND OTHER EXIT WAYS - CLASS C
  - ROOMS AND ENCLOSED SPACES - CLASS C
- ALL FINISHES TO BE APPROVED BY TENANT PRIOR TO INSTALLATION.
- PROVIDE APPROPRIATE HANDICAP ACCESSIBLE THRESHOLDS WHERE FLOOR CHANGES MATERIAL.
- SEE FINISH SCHEDULE FOR PLASTIC LAMINATE COLORS.
- ALL EXISTING DRYWALL WALLS WITHIN THE SCOPE AREA SHALL BE PAINTED W/ TWO COATS FLAT FINISH LATEX PAINT AS REQUIRED TO COVER. ALL WALLS SHALL THEN BE PAINTED WITH ONE COLOR, ONE COAT, SEE FINISH SCHEDULE FOR COLORS.
- THE EXISTING DOORS SHALL BE REFINISHED TO MATCH THE EXISTING ADJACENT.
- PROVIDE MINIMUM CLASS II FLOOR FINISH MATERIALS TO COMPLY WITH MINIMUM CRITICAL RADIANT FLUX IN EXIT PASSAGEWAYS AND CORRIDORS. ALL OTHER AREAS MUST COMPLY WITH THE DOC FF-1 'PULL-TEST' (FPC 16 CFR, PART 1630)
- PAINT NEW EXPOSED ELECTRICAL CABLE DUCTING AND CONDUIT, COLOR TO MATCH WALLS.
- PAINT DOOR AND WINDOW FRAMES WITH TWO COATS SEMI GLOSS LATEX PAINT.

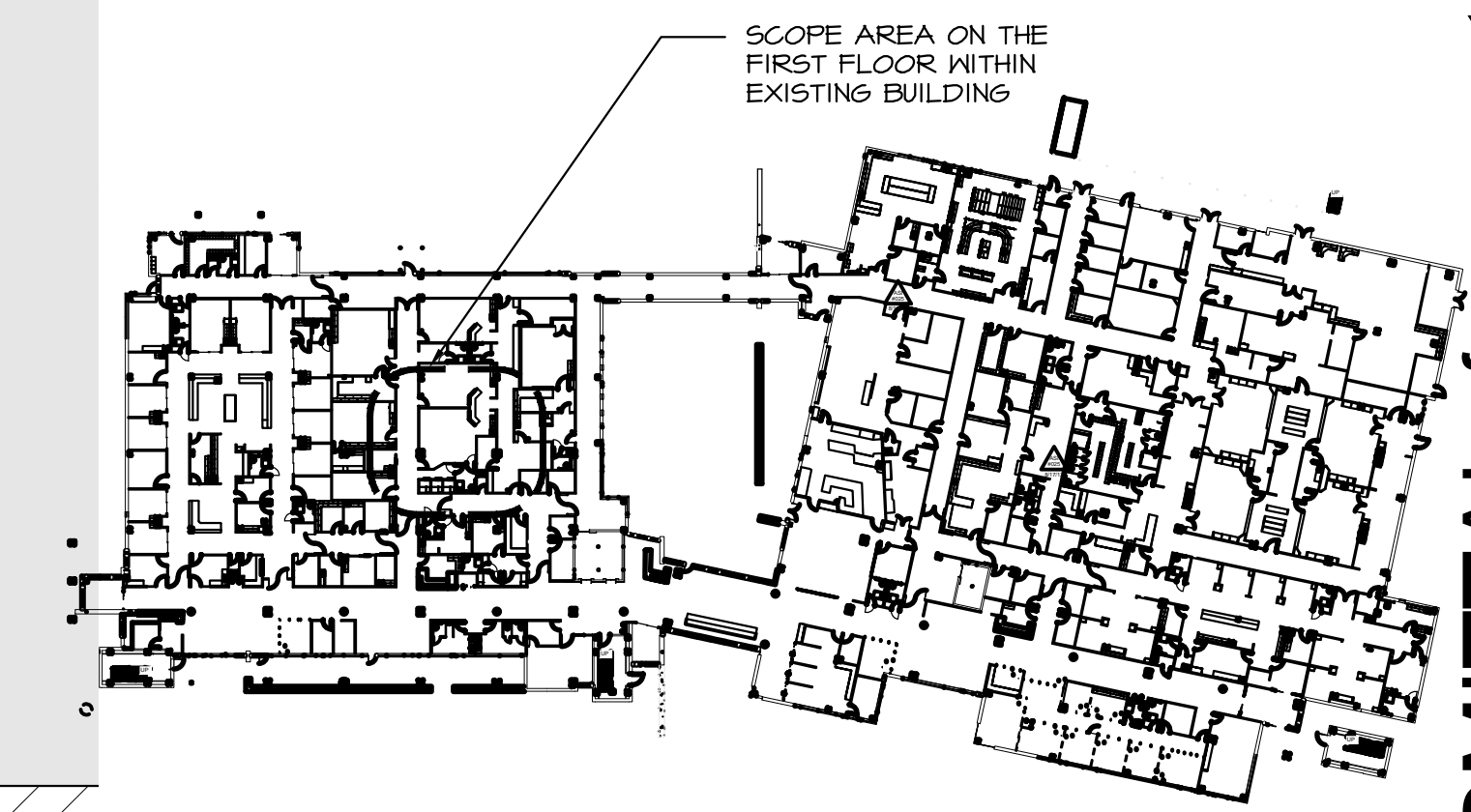
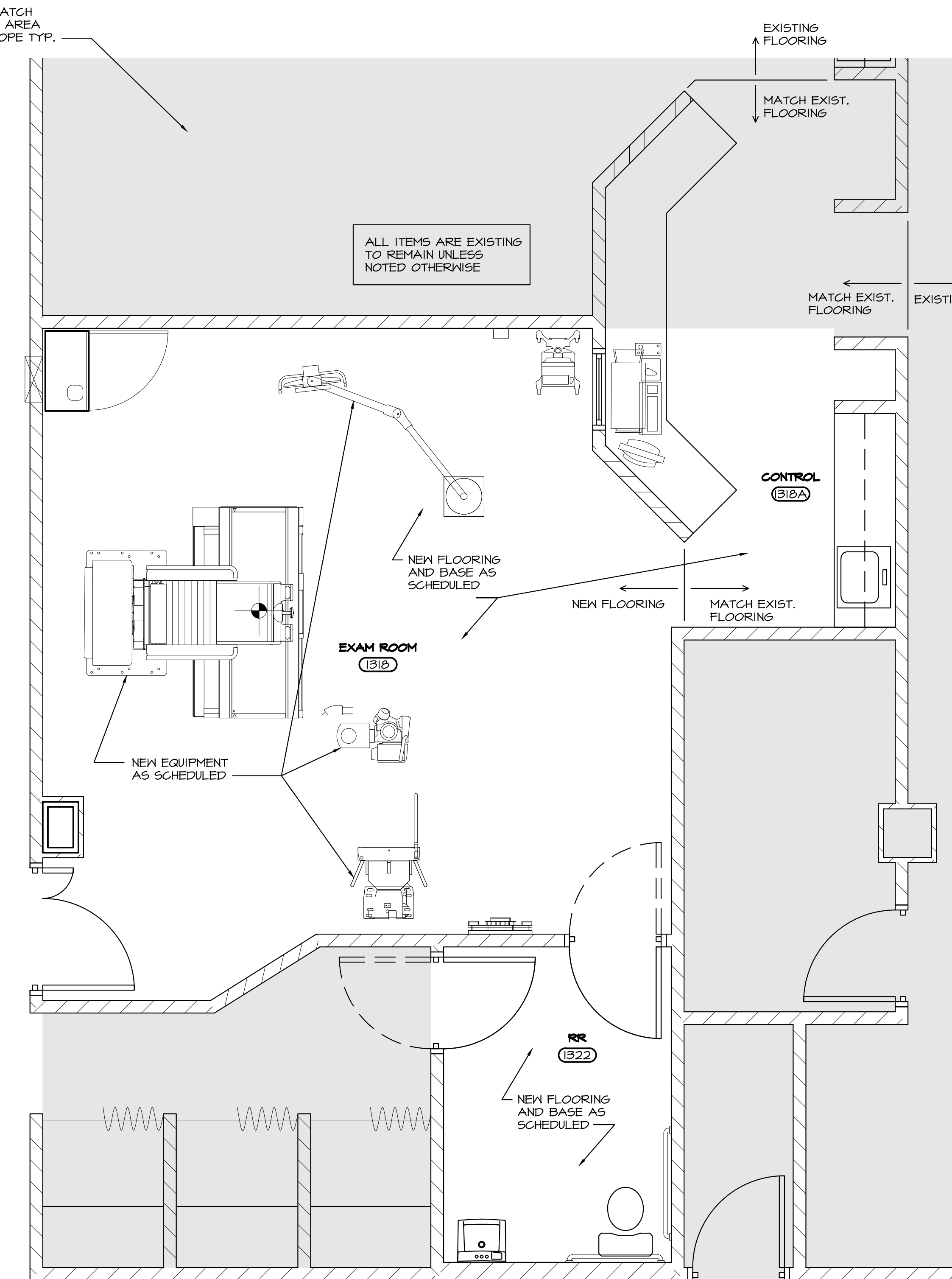
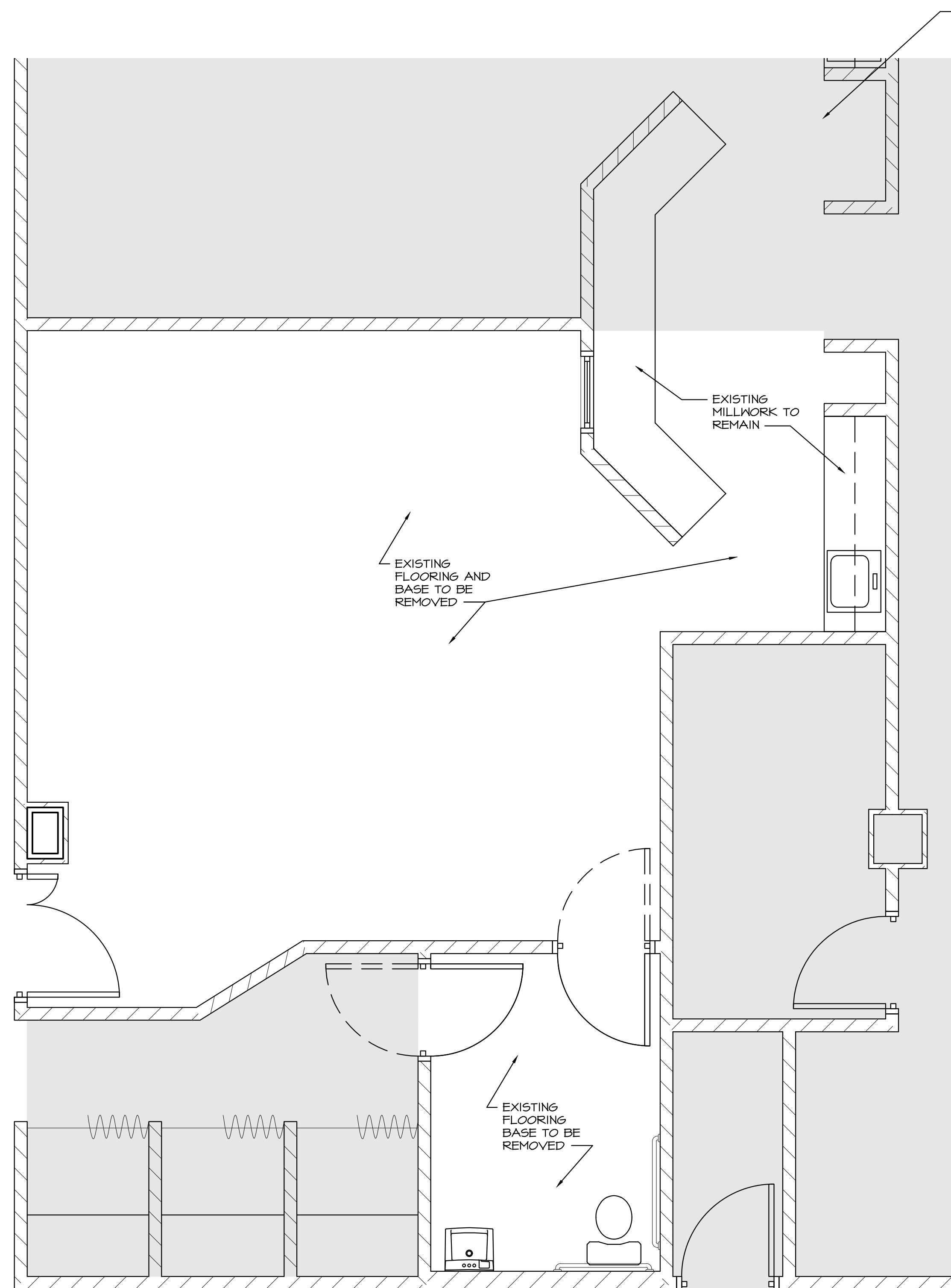

**DEMOLITION PLAN**  
3/8"=1'-0"

**FIRST FLOOR PLAN**  
3/8"=1'-0"

**OVERALL FIRST FLOOR PLAN**  
NTS

**C.D. HAIR ARCHITECT**  
8401 Lake Worth Road  
Suite 119  
Lake Worth, FL  
15034

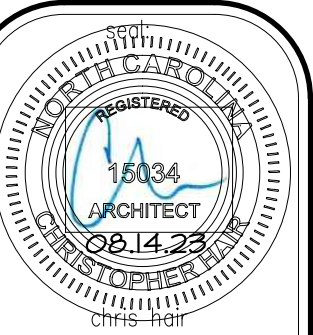





An Interior Renovation for:  
**Harnett Health  
RAD Room 1318 Renovation**  
215 Brighthwater Drive  
Lillington, North Carolina

**FINAL SUBMITTAL for construction**



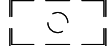

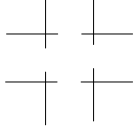
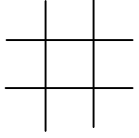
job no. 23-016  
principal: CHRIS HAIR  
CH  
file name:  
date: 08.10.23  
title: DEMO AND FLOOR PLAN

**A210**  
5 A

**CEILING DEMOLITION LEGEND:**

-  EXISTING LIGHT FIXTURE TO BE REMOVED
-  EXISTING LIGHT FIXTURE TO BE SALVAGED FOR REINSTALLATION
-  EXISTING SUPPLY REGISTER TO BE SALVAGED FOR REINSTALLATION
-  EXISTING RETURN REGISTER TO BE SALVAGED FOR REINSTALLATION
-  EXISTING ACOUSTICAL CEILING AND GRID TO BE REMOVED
-  EXISTING CEILING AND INSTALLATIONS TO REMAIN
-  EXISTING FIRE SPRINKLER HEAD TO BE SALVAGED FOR REINSTALLATION

**CEILING LEGEND:**

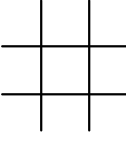
-  EXISTING REINSTALLED 2' x 4' LED LIGHT FIXTURE
  -  NEW 6" RECESSED DIMMABLE LED CAN LIGHT FIXTURE
  -  EXISTING REINSTALLED SUPPLY REGISTER
  -  EXISTING REINSTALLED RETURN REGISTER
  -  EXISTING REINSTALLED FIRE SPRINKLER HEAD
  -  NEW 2 X 2 CEILING IN NEW GRID - PROVIDE TILE AS SPECIFIED
- D = DIMMABLE

**CEILING NOTES:**

1. ALL CEILING MOUNTED ITEMS, INCLUDING LIGHTS, AND HVAC REGISTERS, SHALL BE CENTERED IN THE TILE. ANY CONFLICTS SHALL BE REPORTED TO THE ARCHITECT UPON DISCOVERY. UNDER NO CIRCUMSTANCES SHALL ANY ITEM BE RELOCATED WITHOUT THE ARCHITECT'S APPROVAL.
2. ALL RECTANGULAR ROOMS SHALL HAVE EQUAL BORDERS UNLESS NOTED OTHERWISE. SEE THE PLANS FOR DENOTED STARTING POINTS AND POINTS OF ALIGNMENT.
3. ALL CEILING HEIGHTS FOR SUSPENDED CEILINGS ARE INDICATED ON THE CEILING PLAN.
4. ALL NEW CEILING GRID SHALL BE ATTACHED TO THE ROOF / FLOOR JOISTS ABOVE AT 4'-0" O.C. (MAX) WITH ASTM A641, CLASS 1 ZINC COATED, SOFT TEMPER, PRE-STRETCHED HANGER WIRE (12 GA) MINIMUM. ALL HANGER WIRE SHALL BE INSTALLED PLUMB AND STRAIGHT. GRID SUSPENSION SYSTEM TO MEET ASTM 635-636.

**C.D. HAIR ARCHITECT**  
 8401 Lake Worth Road  
 Suite 119  
 Lake Worth, FL  
**15034**

revision:

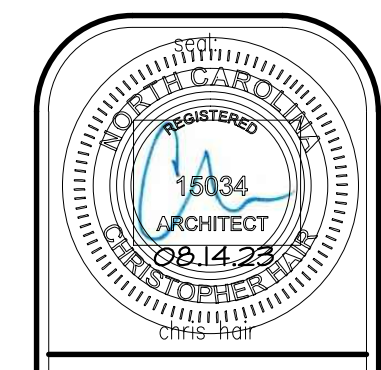



An Interior Renovation for:  
**Harnett Health**  
**RAD Room 1318 Renovation**  
 215 Brighthwater Drive  
 Lillington, North Carolina

FINAL SUBMITTAL for construction

job no. **23-016**  
 principal: **CHRIS HAIR**  
 CH  
 file name:  
 date: **08.10.23**  
 title: **DEMO AND REFLECTED CEILING PLAN**

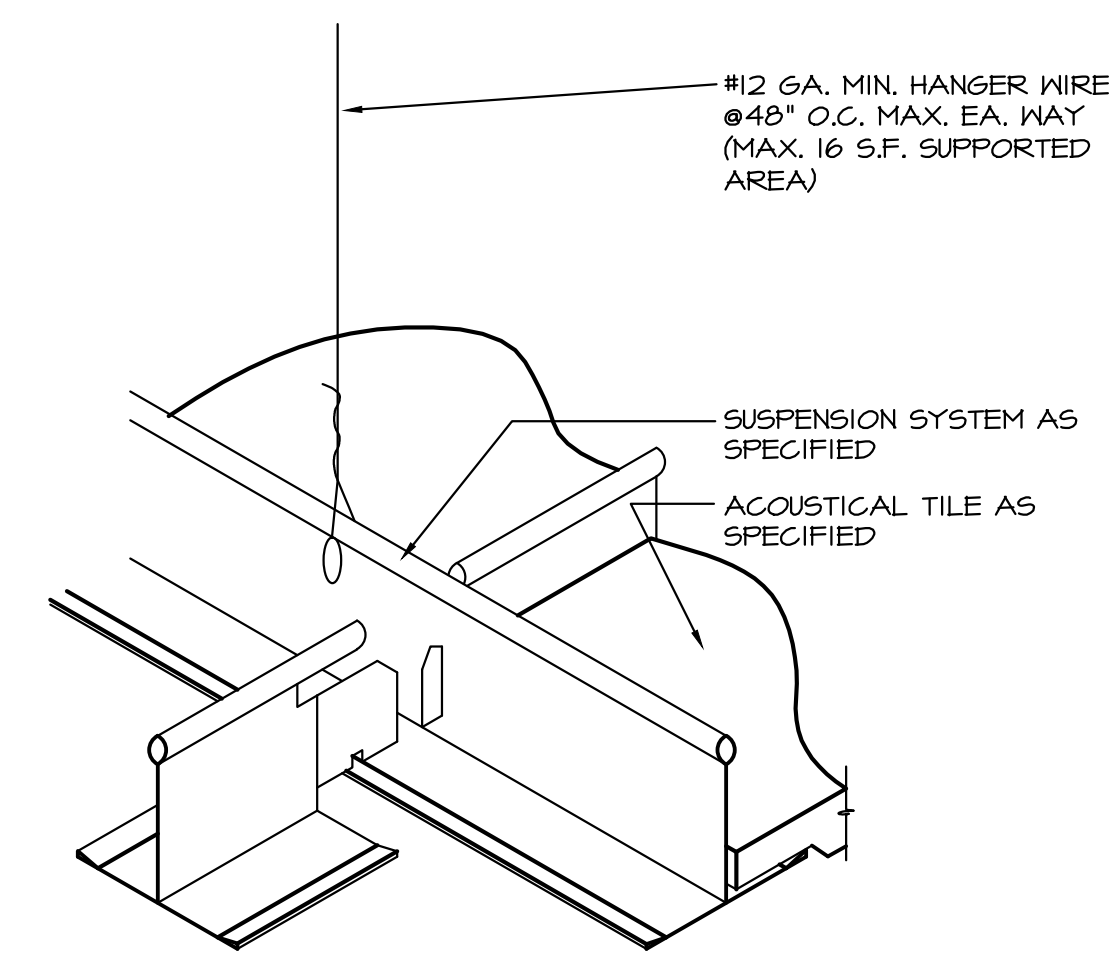
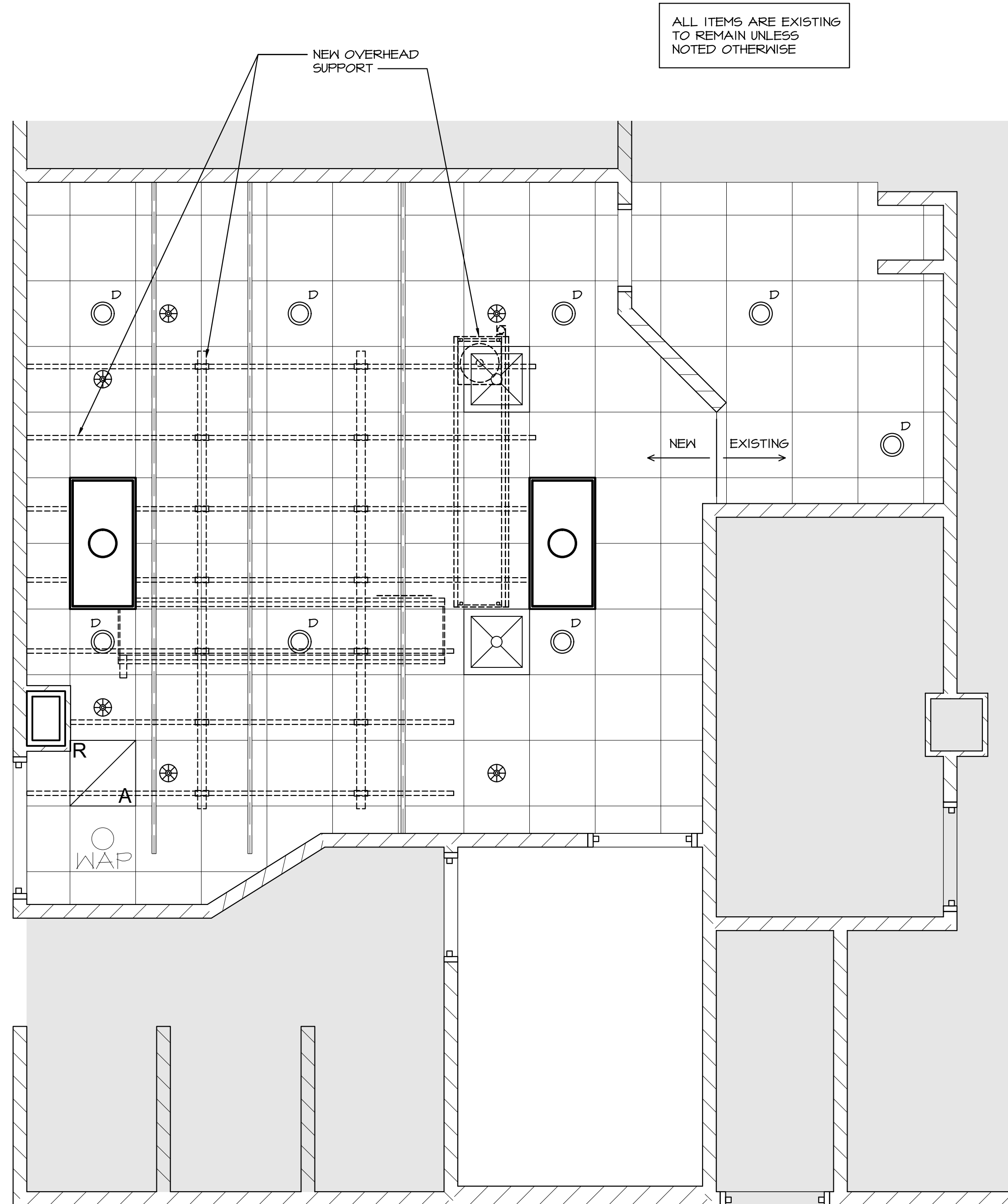
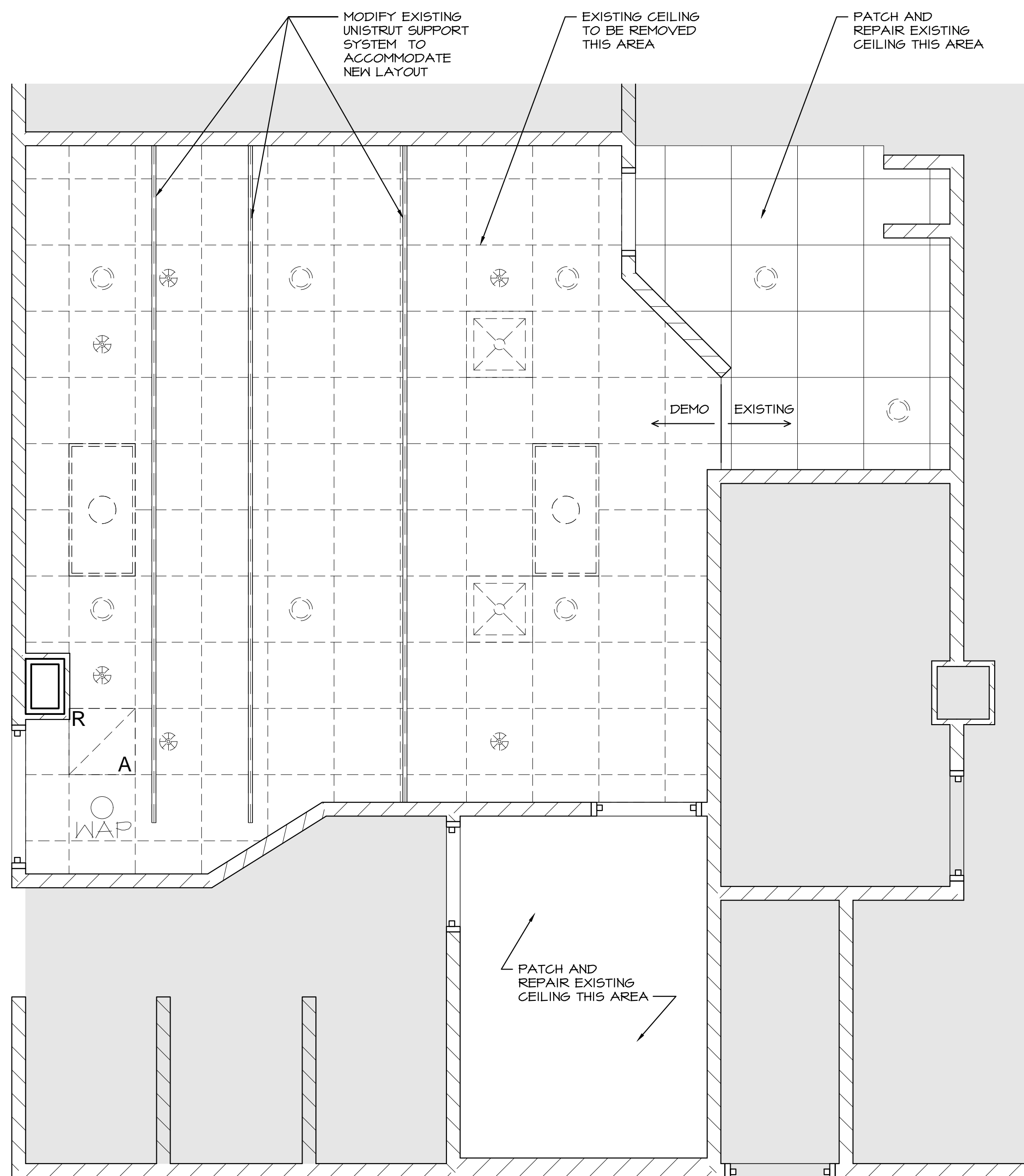
**A410**  
 5 A



**DEMOLITION CEILING PLAN**  
 3/8" = 1'-0"

**REFLECTED CEILING PLAN**  
 3/8" = 1'-0"

**CEILING GRID DETAIL**  
 3" = 1'-0"





# HARNETT HEALTH RAD ROOM 1318

an Interior Renovation for:

215 Brightwater Drive  
Lillington, North Carolina

**ARCHITECT**  
C.D. HAIR ARCHITECT L.L.C.  
8401 LAKE WORTH ROAD, SUITE 119  
LAKE WORTH, FLORIDA 33461  
(561) 209.6050  
chris@cdhairarchitect.com

**MECHANICAL ELECTRICAL**  
THOMPSON YOUNGROSS ENGINEERING CONSULTANTS  
902 CLINT MOORE ROAD, SUITE 142  
BOCA RATON, FLORIDA 33461  
(561) 274.0200  
artur@tecfla.com (Artur Amarel)

**GENERAL CONTRACTOR**  
BLAKE CONTRACTING  
1994 REMOUNT ROAD  
GASTONIA, NORTH CAROLINA 28054  
(704) 868.9930  
blake@blakegc.com (Blake Skarpalezos)



C.D. HAIR ARCHITECT  
8401 Lake Worth Road  
Suite 119  
Lake Worth, FL  
15034

revision:

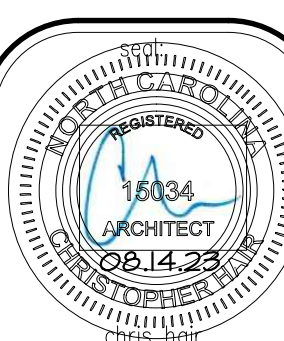

An Interior Renovation for:  
**Harnett Health  
RAD Room 1318 Renovation**  
215 Brightwater Drive  
Lillington, North Carolina

job no. 23-016  
principal: CHRIS HAIR  
CH

file name:  
date: 08.10.23  
title:

TITLE SHEET

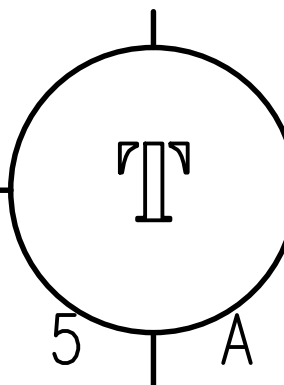

FINAL SUBMITTAL for construction

PROJECT SCOPE	PROJECT DATA	PROJECT CODE TABULAR		SHEET INDEX																		
<p>THE PROJECT INVOLVES AN EQUIPMENT CHANGE-OUT WITHIN AN EXISTING ROOM ON THE FIRST FLOOR WITHIN AN EXISTING IN-PATIENT, HOSPITAL. THE NEWLY RENOVATED SPACE WILL BE USED AS A RAD ROOM. (NO CHANGE TO THE EXISTING FUNCTION OF THE ROOM), NO NEW WALLS, DOORS OR OTHER LAYOUT CHANGES ARE IN THIS SCOPE OF THE RAD ROOM WORK. THE EXISTING FLOOR FINISHES SHALL BE REPLACED, THE EXISTING MILLWORK WILL REMAIN. THE EXISTING LIGHTING SHALL BE REPLACED. THE EXISTING HVAC SHALL REMAIN. THE BUILDING IS MULTI STORY AND ASSUMED TO BE TYPE I-B. THE SCOPE AREA IS PROTECTED BY A FULLY AUTOMATIC FIRE-SPRINKLER SYSTEM.</p> <p>DHSR PROJECT NO.: HL-12893</p> <p><b>VICINITY SKETCH</b> NOT TO SCALE</p>	<p><b>AREA CALCULATIONS:</b></p> <p>SCOPE AREA WITHIN EXIST. HOSPITAL 574 SF</p> <p><b>OCCUPANCY LOAD CALCULATIONS:</b></p> <p>INSTITUTIONAL I-2 574 S.F. / 240 GROSS = 2.39 (3 PEOPLE)</p>	<p><b>MUNICIPALITY:</b> HARNETT COUNTY</p> <p><b>GOVERNING CODES:</b> 2018 NORTH CAROLINA STATE BUILDING CODE BASED ON IBC - 2015 INTERNATIONAL BUILDING CODE W, AMENDMENTS IEBC - 2015 INTERNATIONAL EXISTING BUILDING CODE, '15 INTERNATIONAL FUEL GAS CODE, '15 INTERNATIONAL MECHANICAL CODE, '15 INTERNATIONAL PLUMBING CODE, 2018 FGI GUIDELINES OUTPATIENT FACILITIES, ICC / ANSI-A117.1-2013 ADA STANDARDS, 2017 NCSEC, 2005 U.S. PUBLIC HEALTH CODE, NORTH CAROLINA ADMIN. CODE, DHSR RULES AND REGULATIONS</p> <p><b>OCCUPANCY:</b> GROUP I-2 (INSTITUTIONAL)</p> <p><b>REQUIRED SEPARATION:</b> *NO SEPARATION REQUIRED TO ADJACENT GROUP 'I' TENANTS</p> <p><b>TYPE OF CONSTRUCTION:</b> TYPE I-B</p> <p><b>CLASSIFICATION OF WORK:</b> ALTERATION - LEVEL 2</p> <table border="1"> <thead> <tr> <th></th> <th>REQUIRED</th> <th>PROVIDED</th> </tr> </thead> <tbody> <tr> <td>MIN STAIR WIDTH:</td> <td>44"</td> <td>N/A</td> </tr> <tr> <td>MAX COMMON PATH OF TRAVEL:</td> <td>75'</td> <td>36'-3"</td> </tr> <tr> <td>MAX TRAVEL DISTANCE:</td> <td>200'</td> <td>105'-6"</td> </tr> <tr> <td>MAX DEAD END:</td> <td>20'</td> <td>N/A</td> </tr> <tr> <td>NO. OF EXITS:</td> <td>2</td> <td>2</td> </tr> </tbody> </table> <p>* BUILDING IS PROVIDED WITH A FULLY AUTOMATIC SPRINKLER SYSTEM</p>		REQUIRED	PROVIDED	MIN STAIR WIDTH:	44"	N/A	MAX COMMON PATH OF TRAVEL:	75'	36'-3"	MAX TRAVEL DISTANCE:	200'	105'-6"	MAX DEAD END:	20'	N/A	NO. OF EXITS:	2	2	<p>REV</p> <p>DATE</p>	<p><b>ARCHITECTURAL:</b></p> <p>T TITLE SHEET A010 LIFE SAFETY PLAN A210 DEMO AND FLOOR PLAN A410 DEMO AND REFLECTED CEILING PLAN A910 ICRA COORDINATION PLAN</p> <p><b>ELECTRICAL:</b></p> <p>E0.1 ELECTRICAL NOTES, LEGEND AND SCHEDULES E1.1 FIRST FLOOR ELECTRICAL PLAN E2.1 FIRST FLOOR LIGHTING PLAN E3.1 SIEMENS REFERENCE DESIGN PLANS E3.2 SIEMENS REFERENCE DESIGN PLANS</p> <p><b>MECHANICAL:</b></p> <p>M1.1 FIRST FLOOR MECHANICAL PLAN</p>
	REQUIRED	PROVIDED																				
MIN STAIR WIDTH:	44"	N/A																				
MAX COMMON PATH OF TRAVEL:	75'	36'-3"																				
MAX TRAVEL DISTANCE:	200'	105'-6"																				
MAX DEAD END:	20'	N/A																				
NO. OF EXITS:	2	2																				
<p><b>BUILDING KEY PLAN</b></p>		<p><b>LIFE SAFETY CODE</b></p>																				
<p>SCOPE AREA WITHIN BUILDING</p>		<p><b>GOVERNING CODES:</b> 2015 INTERNATIONAL FIRE CODE NCBC - FPC NFPA 101 LIFE SAFETY CODE - 2012 ED. NFPA 13 LIFE SAFETY CODE - STANDARD FOR THE INSTALLATION OF SPRINKLER SYSTEMS 2013 ED.</p> <p><b>OCCUPANCY:</b> (INSTITUTIONAL)</p> <table border="1"> <thead> <tr> <th></th> <th>REQUIRED</th> <th>PROVIDED</th> </tr> </thead> <tbody> <tr> <td>MAX COMMON PATH OF TRAVEL:</td> <td>75'</td> <td>36'-3"</td> </tr> <tr> <td>MAX TRAVEL DISTANCE:</td> <td>200'</td> <td>105'-6"</td> </tr> <tr> <td>MAX DEAD END:</td> <td>20'</td> <td>N/A</td> </tr> </tbody> </table> <p>* BUILDING IS PROVIDED WITH A FULLY AUTOMATIC SPRINKLER SYSTEM</p>		REQUIRED	PROVIDED	MAX COMMON PATH OF TRAVEL:	75'	36'-3"	MAX TRAVEL DISTANCE:	200'	105'-6"	MAX DEAD END:	20'	N/A								
	REQUIRED	PROVIDED																				
MAX COMMON PATH OF TRAVEL:	75'	36'-3"																				
MAX TRAVEL DISTANCE:	200'	105'-6"																				
MAX DEAD END:	20'	N/A																				

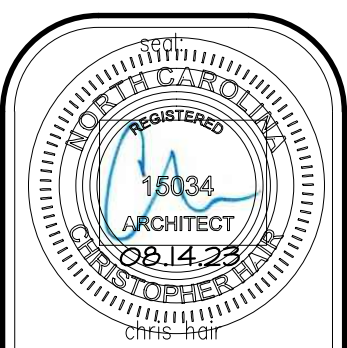

An Interior Renovation for:  
**Harnett Health  
 RAD Room 1318 Renovation**  
 215 Brighwater Drive  
 Lillington, North Carolina

job no. 23-016  
 principal: CHRIS HAIR  
 CH  
 file name:  
 date: 08.10.23  
 title: LIFE SAFETY PLAN

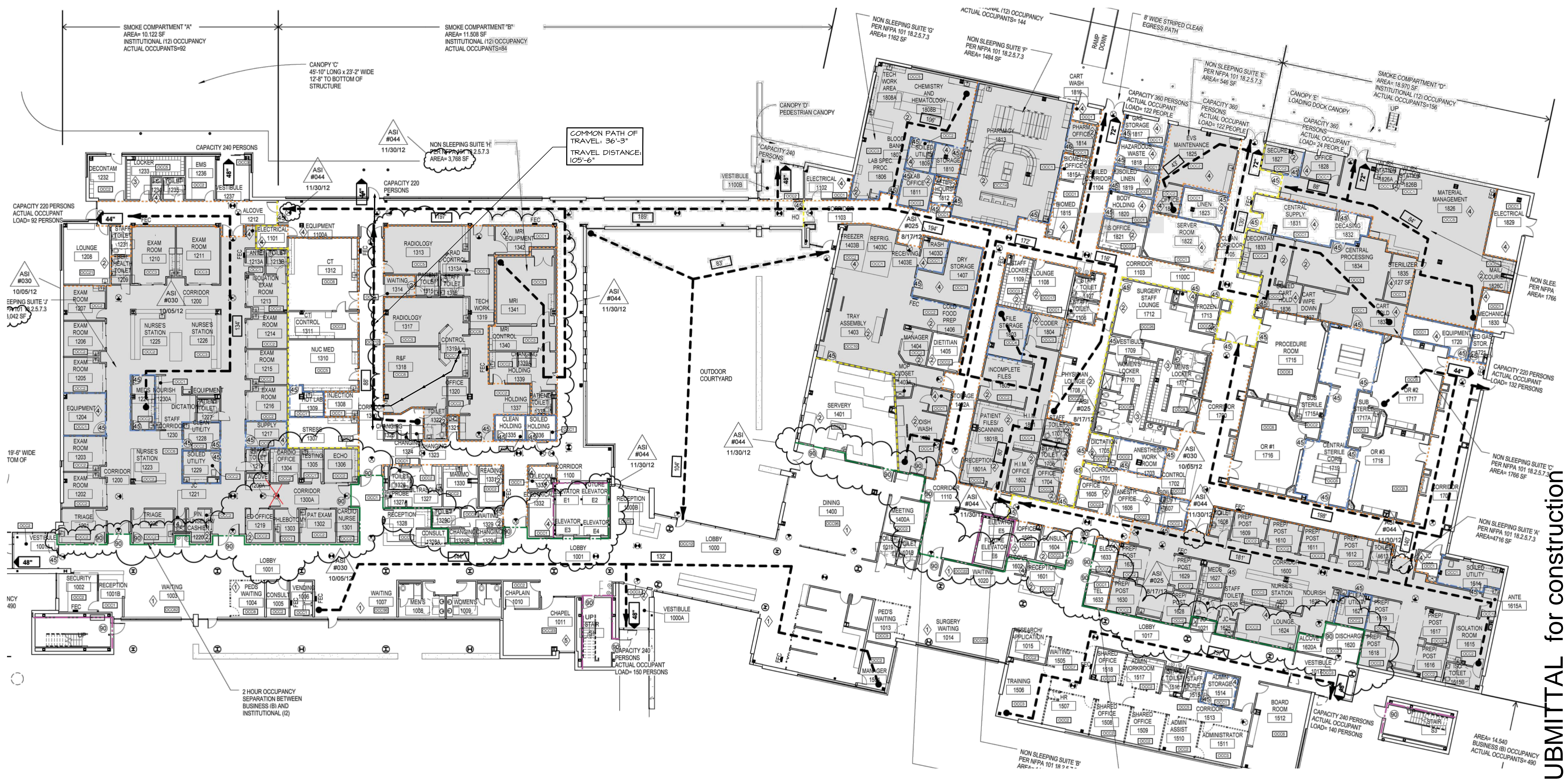

FINAL SUBMITTAL for construction

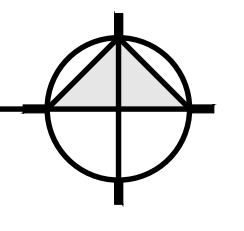

FINISH SCHEDULE						REMARKS
ROOM #	DESCR.	FLOOR	WALLS	BASE	CEILING	
1310	EXAM ROOM	SV-1	PT-1	CB-1	AC-1	
1310A	CONTROL	SV-1	PT-1	CB-1	EX	
1322	RESTROOM	SV-1	PT-1	CB-1	EX	
<b>ABBREV.</b> UNO = UNLESS OTHERWISE NOTED, MS = MANUFACTURER STANDARD, EX = EXISTING, EXP = EXPOSED ALL FINISHES TO BE VERIFIED BY OWNER PRIOR TO PURCHASE AND INSTALL.						

MANUFACTURER SPECIFICATIONS			
DESCR.	MANUF.	MODEL	REMARKS
SHEET VINYL (SV-1)	ME	ME	MATCH EXISTING ADJACENT
COVE BASE (CB-1)	ME	ME	4" INTEGRAL FLASH COVE BASE
PAINT (PT-1)	ME	LATEX PAINT	MATCH EXISTING ADJACENT
PAINT (PT-2)	ME	LATEX PAINT	MATCH EXISTING ADJACENT
<b>ABBREV.</b> UNO = UNLESS OTHERWISE NOTED, MS = MANUFACTURER STANDARD, EX = EXISTING, EXP = EXPOSED, ME = MATCH EXISTING ALL FINISHES TO BE VERIFIED BY OWNER PRIOR TO PURCHASE AND INSTALL.			

**DEMOLITION NOTES:**

- ITEMS SCHEDULED TO BE DEMOLISHED SHALL BE REMOVED IN THEIR ENTIRETY, INCLUDING INSTALLATIONS ABOVE THE CEILING. EXISTING WALLS SHALL BE PATCHED WHERE ITEMS WERE REMOVED TO MATCH ADJACENT SURFACES.
- DUST BARRIERS SHALL BE CONSTRUCTED AND MAINTAINED THROUGH THE COURSE OF CONSTRUCTION TO MINIMIZE THE SPREAD OF CONSTRUCTION DUST.
- PROTECT EXISTING WALLS TO REMAIN. ALL EXISTING WALLS TO REMAIN TO BE FINISHED TO ACHIEVE 'AS NEW' APPEARANCE.
- CONTRACTOR TO PROTECT OR REMOVE CEILING TILE AS REQUIRED IN AREAS WHERE EQUIPMENT IS BEING INSTALLED.
- PATCH EXISTING CEILINGS AS REQUIRED DUE TO INSTALLATION OF OVERHEAD EQUIPMENT.
- REMOVE EXISTING LIGHTING AS SCHEDULED. EXISTING FIRE SPRINKLER HEADS TO BE LEFT INTACT.

**SYMBOL LEGEND:**

- EXISTING WALL TO REMAIN
- EXISTING WINDOW TO REMAIN
- EXISTING DOOR TO REMAIN

**PLAN NOTES:**

- CONTRACTORS TO VERIFY ALL FIELD CONDITIONS PRIOR TO COMMENCEMENT AND REPORT ANY DISCREPANCIES TO THE ARCHITECT
- ALL PENETRATIONS, NEW AND EXISTING THROUGH RATED PARTITIONS MUST MEET UL APPROVED STANDARDS - SUBMIT SYSTEM TO ARCHITECT FOR APPROVAL. FIELD VERIFY PRIOR TO BID.
- PROVIDE SOLID WOOD BACKING FOR ALL WALLS TO RECEIVE COUNTERS, CABINETS, DOOR STOPS, SINKS, TOILET ACCESSORIES, CHAIR RAILS, AND OTHER RELATED INSTALLATIONS. THE INSTALLATIONS SHALL BE INSPECTED BY THE ARCHITECT PRIOR TO COVERING WITH DRYWALL.
- THE NOTE HOLD ON DIMENSION STRINGS INDICATE MINIMUM CLEAR FINISH DIMENSIONS.
- PENETRATIONS THROUGH FIRE RATED PARTITIONS WILL BE FIRE CAULKED WITH THE UL SYSTEM NO. W-L-1044.

**FINISH NOTES:**

- ALL FINISHES SHALL MEET THE REQUIREMENTS OF NCBC 2018 CHAPTER 8, TABLE 803.11:
  - VERTICAL EXITS AND EXIT PASSAGEWAYS - CLASS B
  - EXIT ACCESS CORRIDORS AND OTHER EXIT WAYS - CLASS C
  - ROOMS AND ENCLOSED SPACES - CLASS C
- ALL FINISHES TO BE APPROVED BY TENANT PRIOR TO INSTALLATION.
- PROVIDE APPROPRIATE HANDICAP ACCESSIBLE THRESHOLDS WHERE FLOOR CHANGES MATERIAL.
- SEE FINISH SCHEDULE FOR PLASTIC LAMINATE COLORS.
- ALL EXISTING DRYWALL WALLS WITHIN THE SCOPE AREA SHALL BE PAINTED W/ TWO COATS FLAT FINISH LATEX PAINT AS REQUIRED TO COVER. ALL WALLS SHALL THEN BE PAINTED WITH ONE COLOR, ONE COAT, SEE FINISH SCHEDULE FOR COLORS.
- THE EXISTING DOORS SHALL BE REFINISHED TO MATCH THE EXISTING ADJACENT.
- PROVIDE MINIMUM CLASS II FLOOR FINISH MATERIALS TO COMPLY WITH MINIMUM CRITICAL RADIANT FLUX IN EXIT PASSAGEWAYS AND CORRIDORS. ALL OTHER AREAS MUST COMPLY WITH THE DOC FF-1 'PULL-TEST' (FPC 16 CFR, PART 1630)
- PAINT NEW EXPOSED ELECTRICAL CABLE DUCTING AND CONDUIT, COLOR TO MATCH WALLS.
- PAINT DOOR AND WINDOW FRAMES WITH TWO COATS SEMI GLOSS LATEX PAINT.

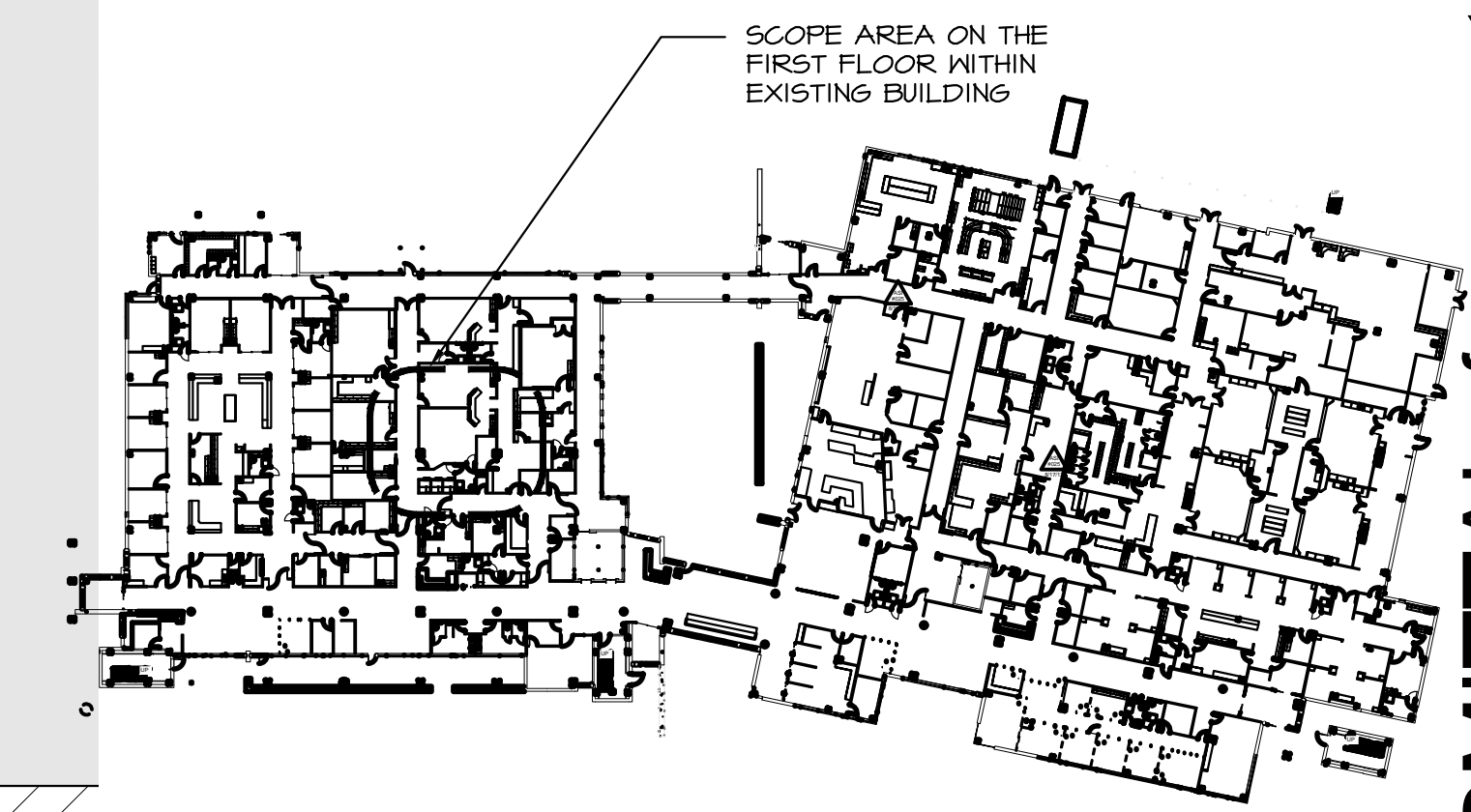
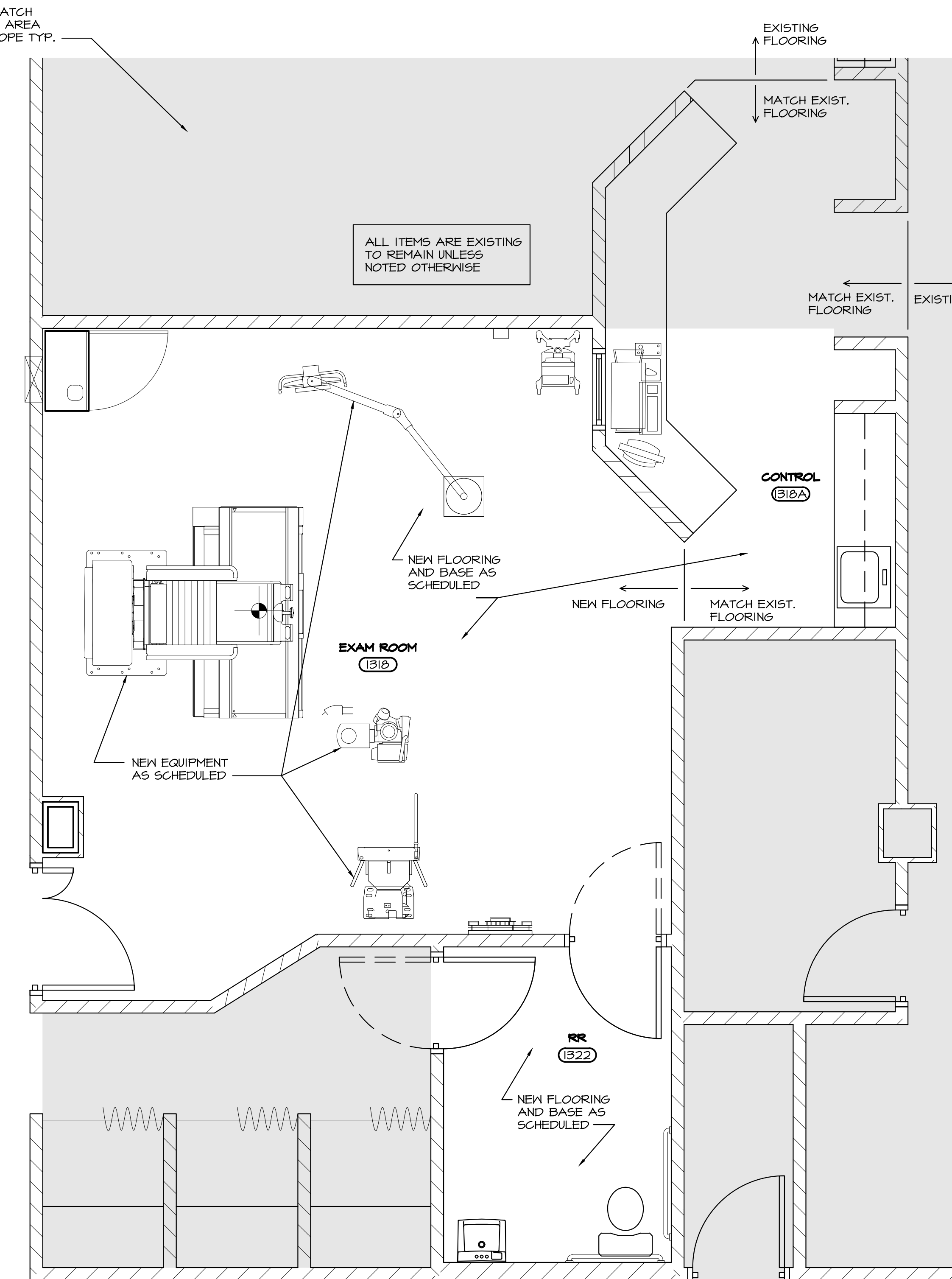
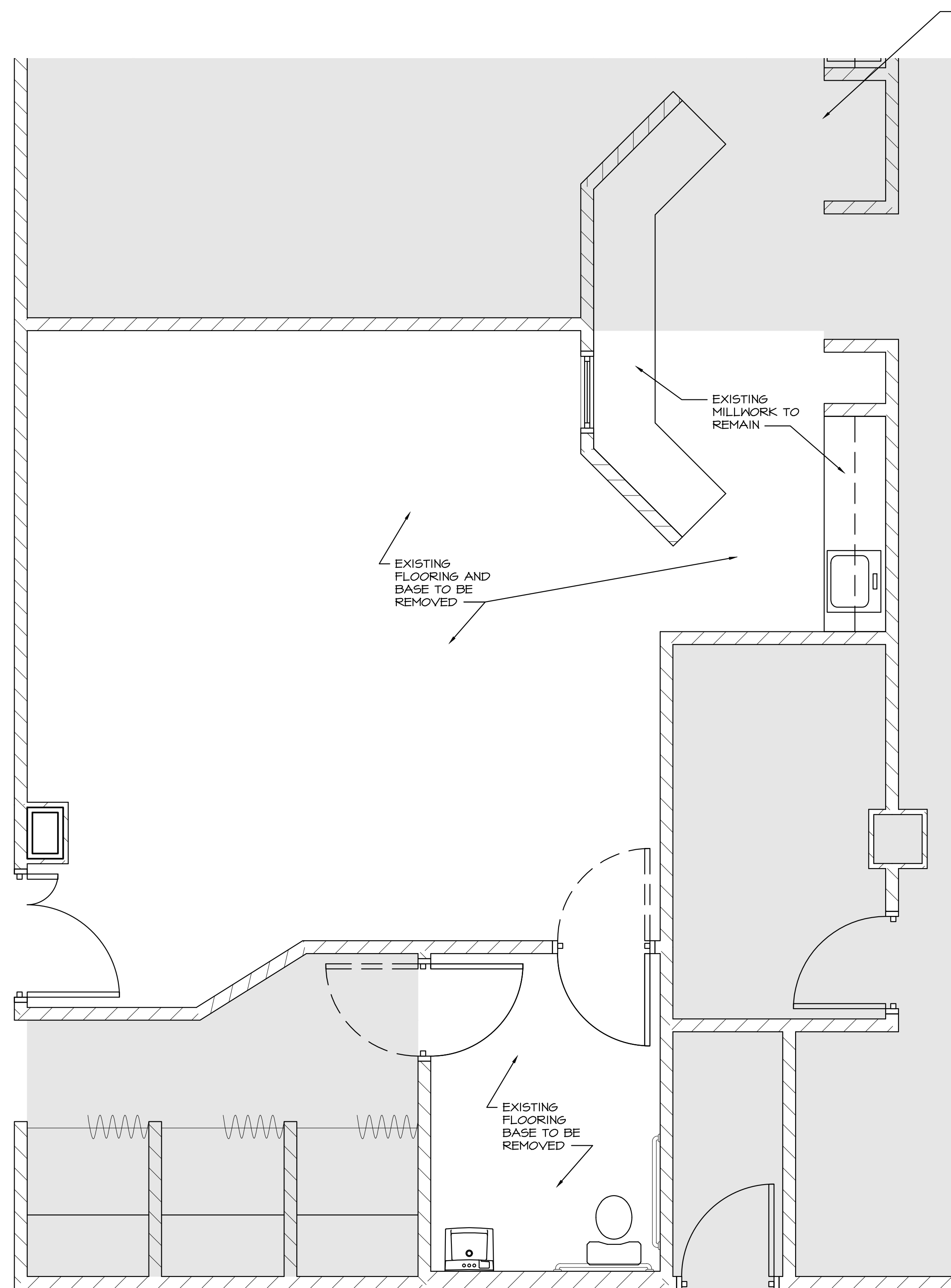

**DEMOLITION PLAN**  
3/8"=1'-0"

**FIRST FLOOR PLAN**  
3/8"=1'-0"

**OVERALL FIRST FLOOR PLAN**  
NTS

**C.D. HAIR ARCHITECT**  
8401 Lake Worth Road  
Suite 119  
Lake Worth, FL  
15034

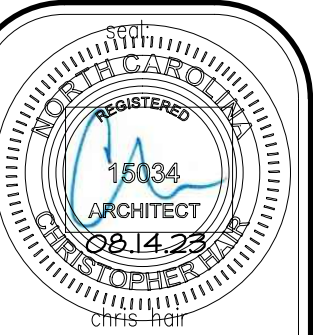





An Interior Renovation for:  
**Harnett Health  
RAD Room 1318 Renovation**  
215 Brighthwater Drive  
Lillington, North Carolina

**FINAL SUBMITTAL for construction**



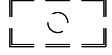

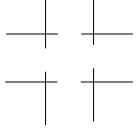
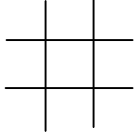
job no. 23-016  
principal: CHRIS HAIR  
CH  
file name:  
date: 08.10.23  
title: DEMO AND FLOOR PLAN

**A210**  
5 A

**CEILING DEMOLITION LEGEND:**

-  EXISTING LIGHT FIXTURE TO BE REMOVED
-  EXISTING LIGHT FIXTURE TO BE SALVAGED FOR REINSTALLATION
-  EXISTING SUPPLY REGISTER TO BE SALVAGED FOR REINSTALLATION
-  EXISTING RETURN REGISTER TO BE SALVAGED FOR REINSTALLATION
-  EXISTING ACOUSTICAL CEILING AND GRID TO BE REMOVED
-  EXISTING CEILING AND INSTALLATIONS TO REMAIN
-  EXISTING FIRE SPRINKLER HEAD TO BE SALVAGED FOR REINSTALLATION

**CEILING LEGEND:**

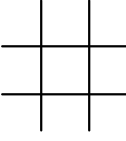
-  EXISTING REINSTALLED 2' x 4' LED LIGHT FIXTURE
  -  NEW 6" RECESSED DIMMABLE LED CAN LIGHT FIXTURE
  -  EXISTING REINSTALLED SUPPLY REGISTER
  -  EXISTING REINSTALLED RETURN REGISTER
  -  EXISTING REINSTALLED FIRE SPRINKLER HEAD
  -  NEW 2 X 2 CEILING IN NEW GRID - PROVIDE TILE AS SPECIFIED
- D = DIMMABLE

**CEILING NOTES:**

1. ALL CEILING MOUNTED ITEMS, INCLUDING LIGHTS, AND HVAC REGISTERS, SHALL BE CENTERED IN THE TILE. ANY CONFLICTS SHALL BE REPORTED TO THE ARCHITECT UPON DISCOVERY. UNDER NO CIRCUMSTANCES SHALL ANY ITEM BE RELOCATED WITHOUT THE ARCHITECT'S APPROVAL.
2. ALL RECTANGULAR ROOMS SHALL HAVE EQUAL BORDERS UNLESS NOTED OTHERWISE. SEE THE PLANS FOR DENOTED STARTING POINTS AND POINTS OF ALIGNMENT.
3. ALL CEILING HEIGHTS FOR SUSPENDED CEILINGS ARE INDICATED ON THE CEILING PLAN.
4. ALL NEW CEILING GRID SHALL BE ATTACHED TO THE ROOF / FLOOR JOISTS ABOVE AT 4'-0" O.C. (MAX) WITH ASTM A641, CLASS 1 ZINC COATED, SOFT TEMPER, PRE-STRETCHED HANGER WIRE (12 GA) MINIMUM. ALL HANGER WIRE SHALL BE INSTALLED PLUMB AND STRAIGHT. GRID SUSPENSION SYSTEM TO MEET ASTM 635-636.

**C.D. HAIR ARCHITECT**  
 8401 Lake Worth Road  
 Suite 119  
 Lake Worth, FL  
**15034**

revision:

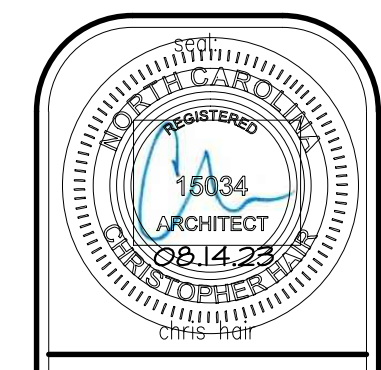
An Interior Renovation for:  
**Harnett Health**  
**RAD Room 1318 Renovation**  
 215 Brighthwater Drive  
 Lillington, North Carolina

FINAL SUBMITTAL for construction



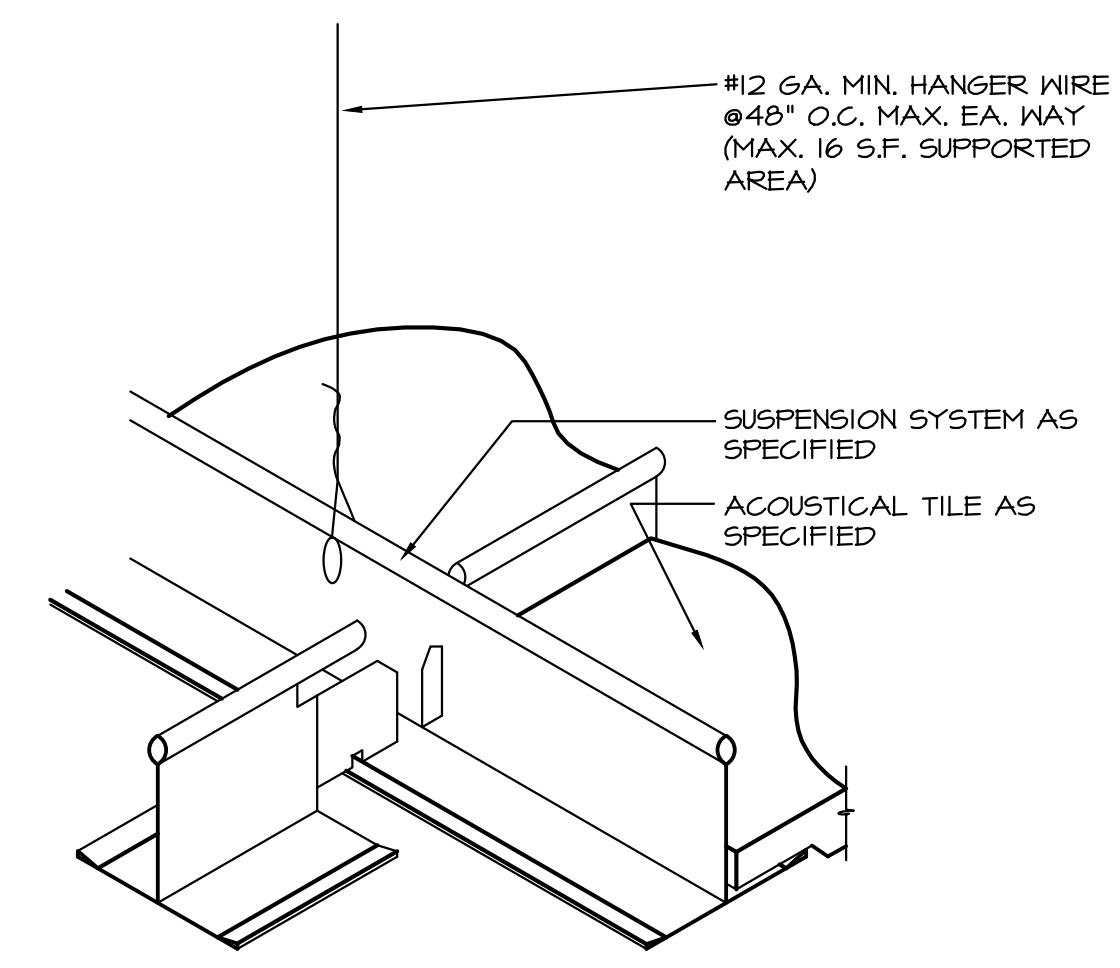
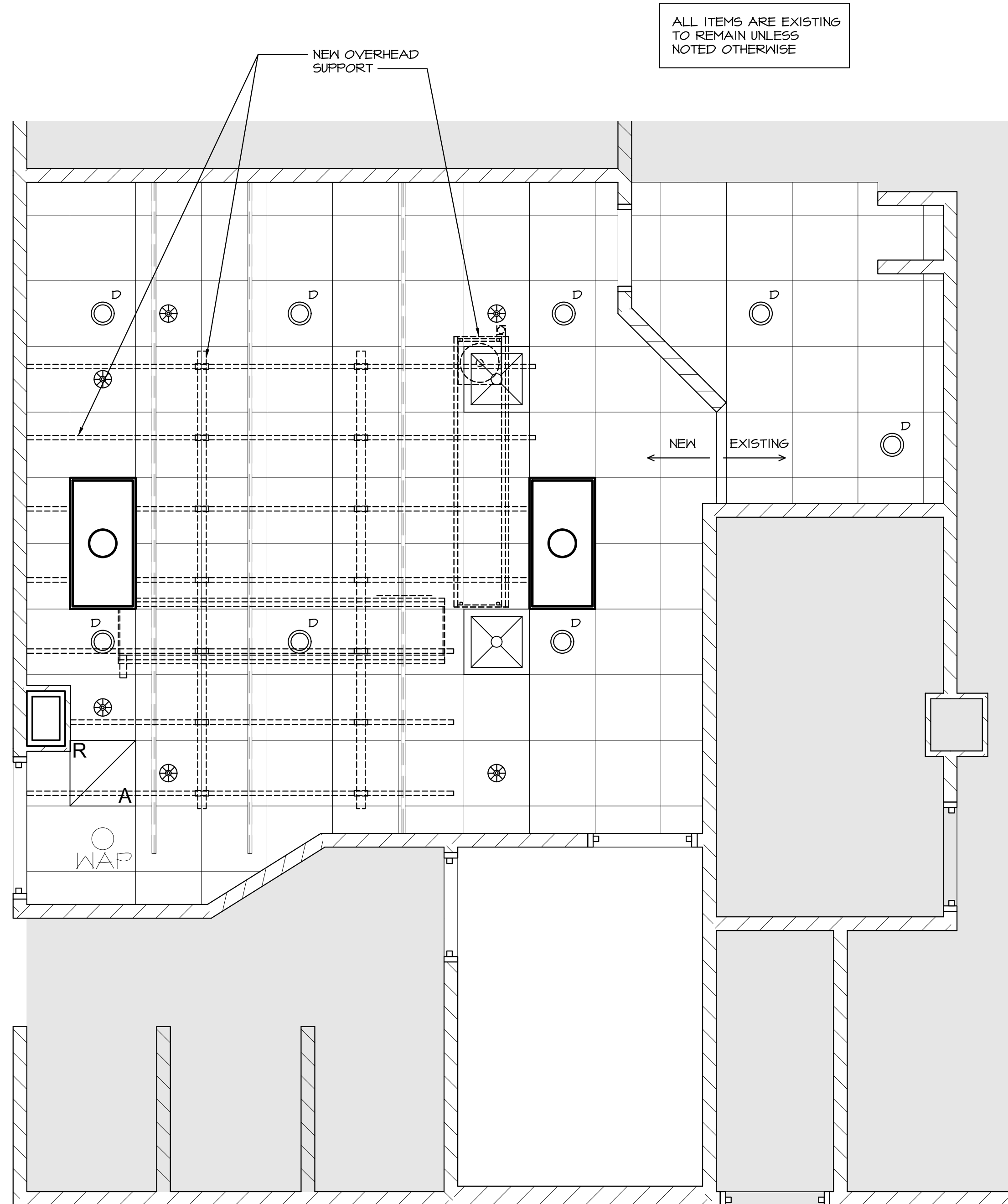
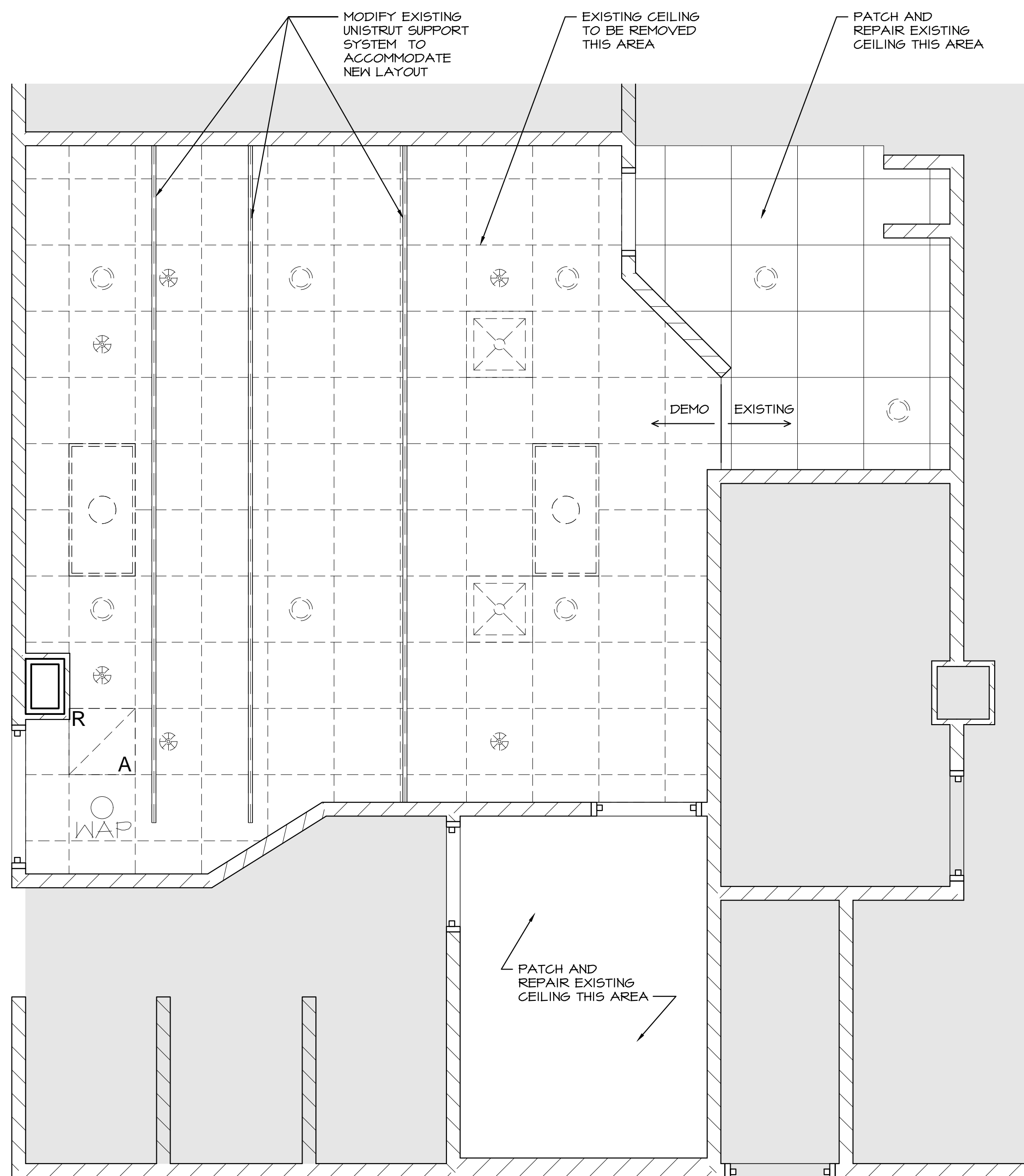

**DEMOLITION CEILING PLAN**  
 3/8" = 1'-0"

**REFLECTED CEILING PLAN**  
 3/8" = 1'-0"

**CEILING GRID DETAIL**  
 3" = 1'-0"

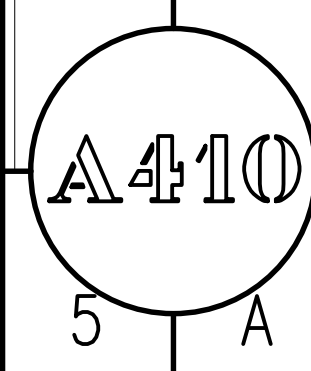
job no. **23-016**  
 principal: **CHRIS HAIR**  
 CH  
 file name:  
 date: **08.10.23**  
 title: **DEMO AND REFLECTED CEILING PLAN**



**ICRA PLAN NOTES**

1. THE GENERAL CONTRACTOR SHALL BECOME FAMILIAR WITH THE PROJECT SITE AND NOTIFY THE ARCHITECT IMMEDIATELY OF DISCREPANCIES.

**PLAN KEYNOTES**

① PRIOR TO CONSTRUCTION, SEAL OFF APPLICABLE SITE SUPPLY AND RETURN AIR DIFFUSERS AND GRILLES TO MINIMIZE DUST CONTAMINATION OF DUCTWORK AND SURROUNDING AREAS. PROVIDE NEGATIVE PRESSURE WITHIN THE PROJECT AREA RELATIVE TO THE AREAS SURROUNDING THE PROJECT AREA AS WELL AS HEPA AIR FILTRATION. PROVIDE MEANS OF MONITORING THE AIR PRESSURE FOR THE ENTIRE DURATION OF CONSTRUCTION.

② SEAL EXISTING AREA WITH FIRE RETARDANT VISQUEEN ABOVE THE CEILING. TAPE PERIMETER SUCH THAT AN AIR TIGHT BARRIER IS ACHIEVED.

③ PROVIDE WALK-OFF MAT

④ PROVIDE TEMPORARY ZIPWALL CONTAINMENT BARRIER

**ICRA CLASSIFICATION DATA**

CONSTRUCTION TYPE: I-B  
 CONSTRUCTION CLASS: II  
 RISK CLASS: MEDIUM

CONSTRUCTION PROTOCOLS

DURING CONSTRUCTION	UPON COMPLETION
1. SEAL SITE SUPPLY AND RETURN AIR DIFFUSERS.	1. DO NOT REMOVE BARRIERS FROM WORK AREA UNTIL COMPLETED PROJECT IS INSPECTED BY THE OWNERS SAFETY DEPARTMENT AND INFECTION CONTROL DEPARTMENT AND THOROUGHLY CLEANED BY THE OWNERS ENVIRONMENTAL SERVICES DEPARTMENT.
2. INSTALL TEMPORARY ZIPWALL BARRIER AS SHOWN ON DETAIL 1, THIS SHEET.	2. REMOVE BARRIER MATERIALS CAREFULLY TO MINIMIZE SPREADING OF DIRT AND DEBRIS ASSOCIATED WITH CONSTRUCTION.
3. PROVIDE A TEMPORARY NEGATIVE AIR UNIT WITH HEPA FILTRATION TO PLACE PROJECT SITE AT NEGATIVE PRESSURE.	3. VACUUM WORK AREA WITH HEPA FILTERED VACUUMS.
4. PROVIDE SHOE COVERS AND TEMPORARY WALK OFF ADHESIVE MATS AT EXIT OF PROJECT AREA.	4. WET MOP AREA WITH DISINFECTANT.
5. CONTAIN CONSTRUCTION WASTE BEFORE TRANSPORT IN TIGHTLY COVERED CONTAINERS.	5. REMOVE ISOLATION OF HVAC SYSTEM IN AREAS WHERE WORK IS BEING PERFORMED.

**C.D. HAIR ARCHITECT**  
 8407 Lake Worth Road  
 Suite 119  
 Lake Worth, FL  
 15034

revision:

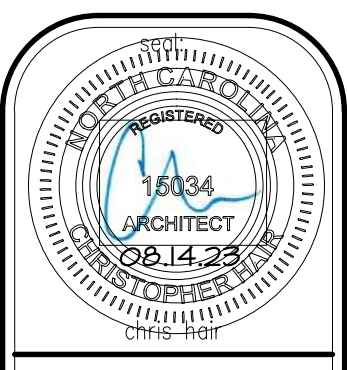



An Interior Renovation for:  
**Hennett Health  
 RAD Room 1318 Renovation**  
 215 Brighthouse Drive  
 Lillington, North Carolina

FINAL SUBMITTAL for construction

job no. 23-016  
 principal: CHRIS HAIR  
 CH  
 file name:  
 date: 08.10.23  
 title: ICRA COORDINATION PLAN

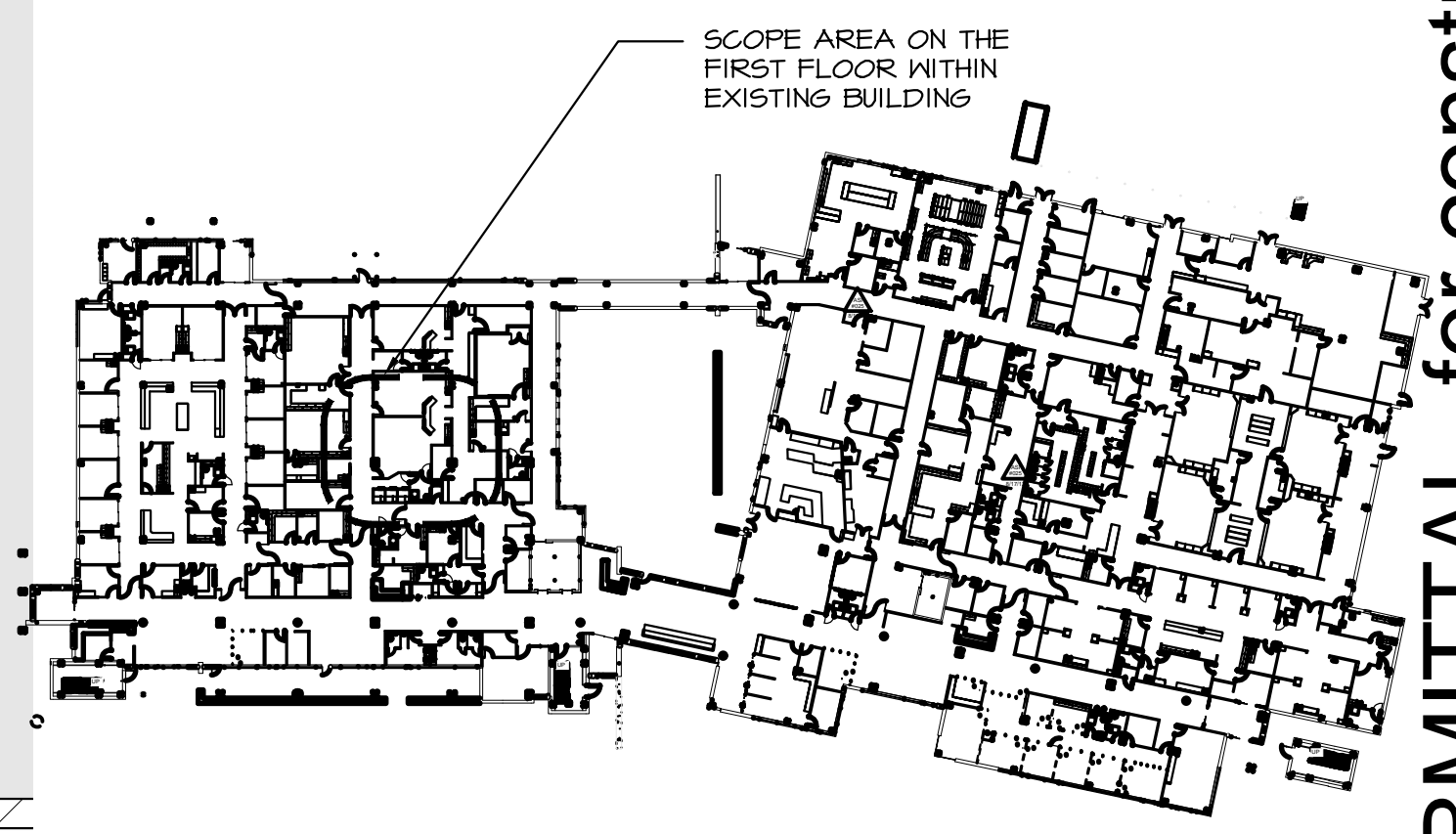
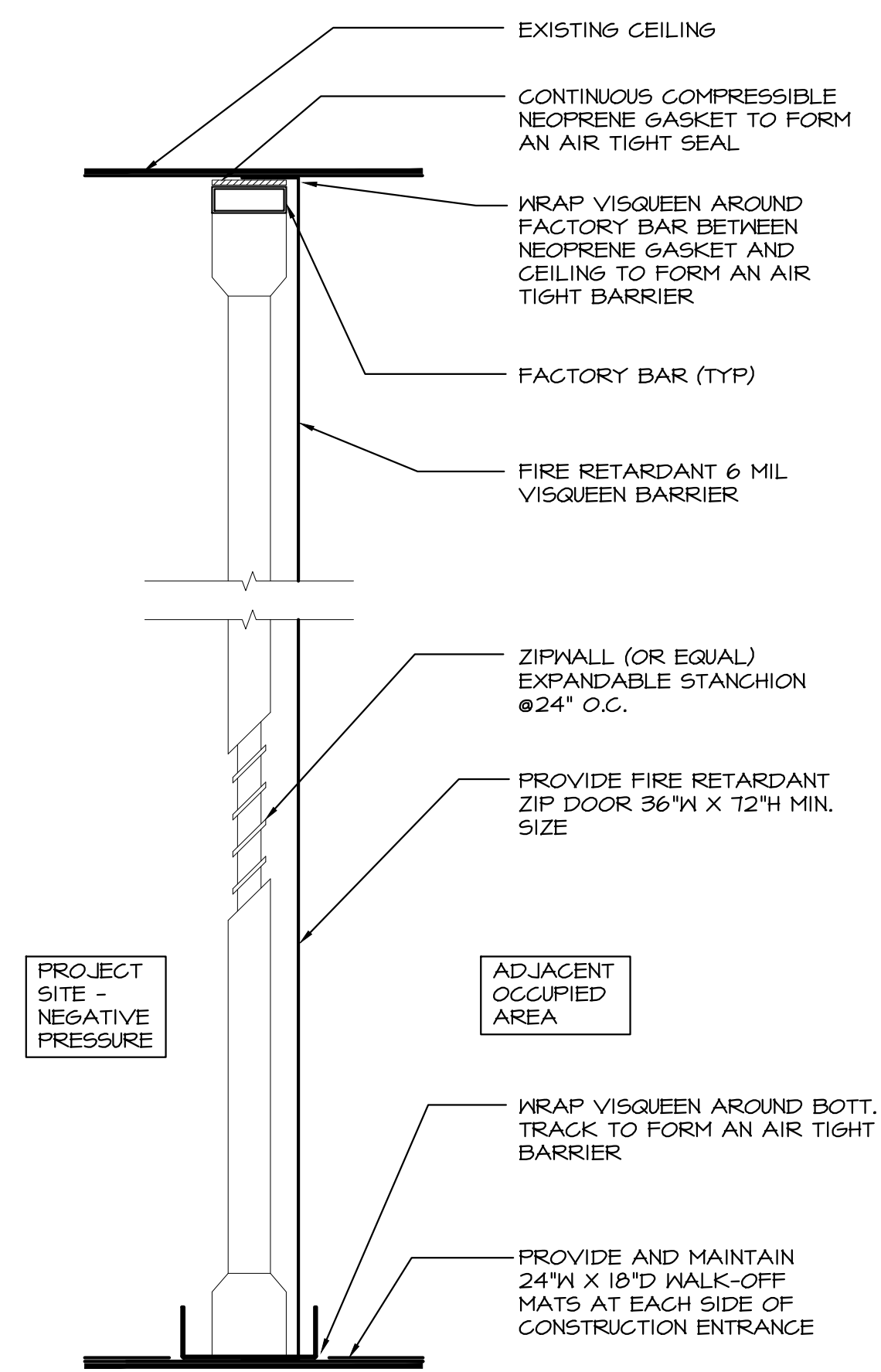
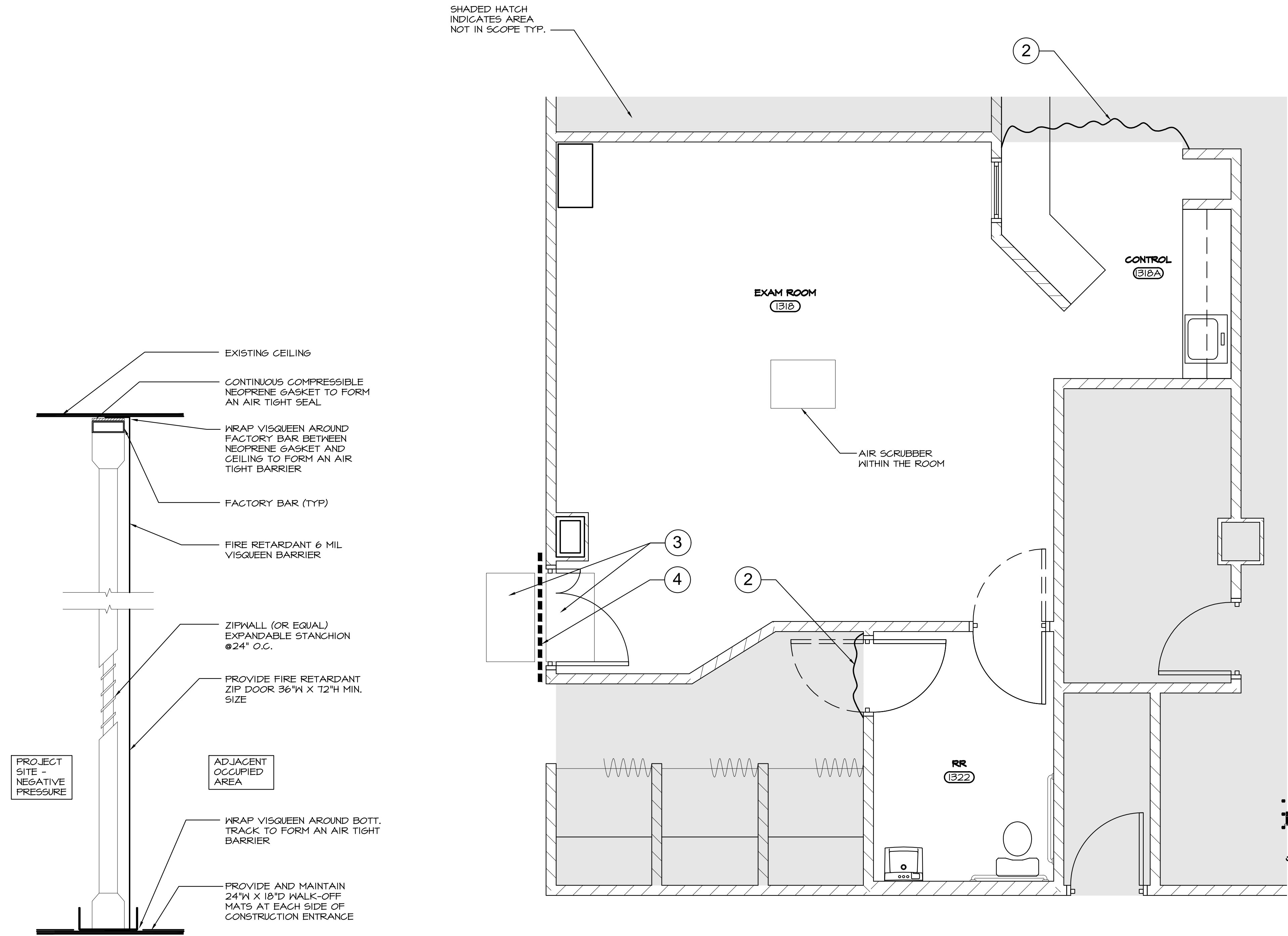
**A910**  
 5 A



**TEMPORARY ZIPWALL CONTAINMENT BARRIER**  
 3/8" = 1'-0"

**ICRA COORDINATION PLAN**  
 3/8" = 1'-0"

**OVERALL FIRST FLOOR PLAN**  
 NTS

# HARNETT HEALTH RAD ROOM 1318

an Interior Renovation for:

215 Brightwater Drive  
Lillington, North Carolina

**ARCHITECT**  
C.D. HAIR ARCHITECT L.L.C.  
8401 LAKE WORTH ROAD, SUITE 119  
LAKE WORTH, FLORIDA 33461  
(561) 209.6050  
chris@cdhairarchitect.com

**MECHANICAL ELECTRICAL**  
THOMPSON YOUNGROSS ENGINEERING CONSULTANTS  
902 CLINT MOORE ROAD, SUITE 142  
BOCA RATON, FLORIDA 33461  
(561) 274.0200  
artur@tecfla.com (Artur Amarel)

**GENERAL CONTRACTOR**  
BLAKE CONTRACTING  
1994 REMOUNT ROAD  
GASTONIA, NORTH CAROLINA 28054  
(704) 868.9930  
blake@blakegc.com (Blake Skarpalezos)



C.D. HAIR ARCHITECT  
8401 Lake Worth Road  
Suite 119  
Lake Worth, FL  
15034

revision:

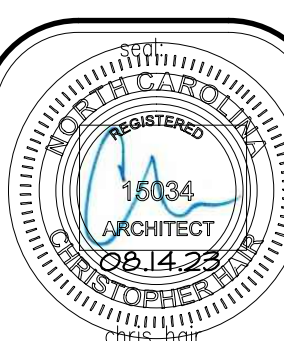

An Interior Renovation for:  
**Harnett Health  
RAD Room 1318 Renovation**  
215 Brightwater Drive  
Lillington, North Carolina

job no. 23-016  
principal: CHRIS HAIR  
CH

file name:

date: 08.10.23  
title:

TITLE SHEET

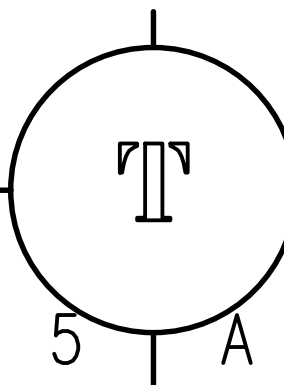

FINAL SUBMITTAL for construction

PROJECT SCOPE	PROJECT DATA	PROJECT CODE TABULAR		SHEET INDEX																		
<p>THE PROJECT INVOLVES AN EQUIPMENT CHANGE-OUT WITHIN AN EXISTING ROOM ON THE FIRST FLOOR WITHIN AN EXISTING IN-PATIENT, HOSPITAL. THE NEWLY RENOVATED SPACE WILL BE USED AS A RAD ROOM. (NO CHANGE TO THE EXISTING FUNCTION OF THE ROOM), NO NEW WALLS, DOORS OR OTHER LAYOUT CHANGES ARE IN THIS SCOPE OF THE RAD ROOM WORK. THE EXISTING FLOOR FINISHES SHALL BE REPLACED, THE EXISTING MILLWORK WILL REMAIN. THE EXISTING LIGHTING SHALL BE REPLACED. THE EXISTING HVAC SHALL REMAIN. THE BUILDING IS MULTI STORY AND ASSUMED TO BE TYPE I-B. THE SCOPE AREA IS PROTECTED BY A FULLY AUTOMATIC FIRE-SPRINKLER SYSTEM.</p> <p>DHSR PROJECT NO.: HL-12893</p> <p><b>VICINITY SKETCH</b> NOT TO SCALE</p>	<p><b>AREA CALCULATIONS:</b></p> <p>SCOPE AREA WITHIN EXIST. HOSPITAL 574 SF</p> <p><b>OCCUPANCY LOAD CALCULATIONS:</b></p> <p>INSTITUTIONAL I-2 574 S.F. / 240 GROSS = 2.39 (3 PEOPLE)</p>	<p><b>MUNICIPALITY:</b> HARNETT COUNTY</p> <p><b>GOVERNING CODES:</b> 2018 NORTH CAROLINA STATE BUILDING CODE BASED ON IBC - 2015 INTERNATIONAL BUILDING CODE W, AMENDMENTS IEBC - 2015 INTERNATIONAL EXISTING BUILDING CODE, '15 INTERNATIONAL FUEL GAS CODE, '15 INTERNATIONAL MECHANICAL CODE, '15 INTERNATIONAL PLUMBING CODE, 2018 FGI GUIDELINES OUTPATIENT FACILITIES, ICC / ANSI-A117.1-2013 ADA STANDARDS, 2017 NCSEC, 2005 U.S. PUBLIC HEALTH CODE, NORTH CAROLINA ADMIN. CODE, DHSR RULES AND REGULATIONS</p> <p><b>OCCUPANCY:</b> GROUP I-2 (INSTITUTIONAL)</p> <p><b>REQUIRED SEPARATION:</b> *NO SEPARATION REQUIRED TO ADJACENT GROUP 'I' TENANTS</p> <p><b>TYPE OF CONSTRUCTION:</b> TYPE I-B</p> <p><b>CLASSIFICATION OF WORK:</b> ALTERATION - LEVEL 2</p> <table border="1"> <thead> <tr> <th></th> <th>REQUIRED</th> <th>PROVIDED</th> </tr> </thead> <tbody> <tr> <td>MIN STAIR WIDTH:</td> <td>44"</td> <td>N/A</td> </tr> <tr> <td>MAX COMMON PATH OF TRAVEL:</td> <td>75'</td> <td>36'-3"</td> </tr> <tr> <td>MAX TRAVEL DISTANCE:</td> <td>200'</td> <td>105'-6"</td> </tr> <tr> <td>MAX DEAD END:</td> <td>20'</td> <td>N/A</td> </tr> <tr> <td>NO. OF EXITS:</td> <td>2</td> <td>2</td> </tr> </tbody> </table> <p>* BUILDING IS PROVIDED WITH A FULLY AUTOMATIC SPRINKLER SYSTEM</p>		REQUIRED	PROVIDED	MIN STAIR WIDTH:	44"	N/A	MAX COMMON PATH OF TRAVEL:	75'	36'-3"	MAX TRAVEL DISTANCE:	200'	105'-6"	MAX DEAD END:	20'	N/A	NO. OF EXITS:	2	2	<p>REV DATE</p>	<p><b>ARCHITECTURAL:</b></p> <p>T TITLE SHEET A010 LIFE SAFETY PLAN A210 DEMO AND FLOOR PLAN A410 DEMO AND REFLECTED CEILING PLAN A910 ICRA COORDINATION PLAN</p> <p><b>ELECTRICAL:</b></p> <p>E0.1 ELECTRICAL NOTES, LEGEND AND SCHEDULES E1.1 FIRST FLOOR ELECTRICAL PLAN E2.1 FIRST FLOOR LIGHTING PLAN E3.1 SIEMENS REFERENCE DESIGN PLANS E3.2 SIEMENS REFERENCE DESIGN PLANS</p> <p><b>MECHANICAL:</b></p> <p>M1.1 FIRST FLOOR MECHANICAL PLAN</p>
	REQUIRED	PROVIDED																				
MIN STAIR WIDTH:	44"	N/A																				
MAX COMMON PATH OF TRAVEL:	75'	36'-3"																				
MAX TRAVEL DISTANCE:	200'	105'-6"																				
MAX DEAD END:	20'	N/A																				
NO. OF EXITS:	2	2																				
<p><b>BUILDING KEY PLAN</b></p>		<p><b>LIFE SAFETY CODE</b></p>																				
<p>SCOPE AREA WITHIN BUILDING</p>		<p><b>GOVERNING CODES:</b> 2015 INTERNATIONAL FIRE CODE NCBC - FPC NFPA 101 LIFE SAFETY CODE - 2012 ED. NFPA 13 LIFE SAFETY CODE - STANDARD FOR THE INSTALLATION OF SPRINKLER SYSTEMS 2013 ED.</p> <p><b>OCCUPANCY:</b> (INSTITUTIONAL)</p> <table border="1"> <thead> <tr> <th></th> <th>REQUIRED</th> <th>PROVIDED</th> </tr> </thead> <tbody> <tr> <td>MAX COMMON PATH OF TRAVEL:</td> <td>75'</td> <td>36'-3"</td> </tr> <tr> <td>MAX TRAVEL DISTANCE:</td> <td>200'</td> <td>105'-6"</td> </tr> <tr> <td>MAX DEAD END:</td> <td>20'</td> <td>N/A</td> </tr> </tbody> </table> <p>* BUILDING IS PROVIDED WITH A FULLY AUTOMATIC SPRINKLER SYSTEM</p>		REQUIRED	PROVIDED	MAX COMMON PATH OF TRAVEL:	75'	36'-3"	MAX TRAVEL DISTANCE:	200'	105'-6"	MAX DEAD END:	20'	N/A								
	REQUIRED	PROVIDED																				
MAX COMMON PATH OF TRAVEL:	75'	36'-3"																				
MAX TRAVEL DISTANCE:	200'	105'-6"																				
MAX DEAD END:	20'	N/A																				



FINISH SCHEDULE						REMARKS
ROOM #	DESCR.	FLOOR	WALLS	BASE	CEILING	
1310	EXAM ROOM	SV-1	PT-1	CB-1	AC-1	
1310A	CONTROL	SV-1	PT-1	CB-1	EX	
1322	RESTROOM	SV-1	PT-1	CB-1	EX	
<b>ABBREV.</b> UNO = UNLESS OTHERWISE NOTED, MS = MANUFACTURER STANDARD, EX = EXISTING, EXP = EXPOSED <b>NOTES</b> ALL FINISHES TO BE VERIFIED BY OWNER PRIOR TO PURCHASE AND INSTALL.						

MANUFACTURER SPECIFICATIONS			
DESCR.	MANUF.	MODEL	REMARKS
SHEET VINYL (SV-1)	ME	ME	MATCH EXISTING ADJACENT
COVE BASE (CB-1)	ME	ME	4" INTEGRAL FLASH COVE BASE
PAINT (PT-1)	ME	LATEX PAINT	MATCH EXISTING ADJACENT
PAINT (PT-2)	ME	LATEX PAINT	MATCH EXISTING ADJACENT
<b>ABBREV.</b> UNO = UNLESS OTHERWISE NOTED, MS = MANUFACTURER STANDARD, EX = EXISTING, EXP = EXPOSED, ME = MATCH EXISTING <b>NOTES</b> ALL FINISHES TO BE VERIFIED BY OWNER PRIOR TO PURCHASE AND INSTALL.			

**DEMOLITION NOTES:**

- ITEMS SCHEDULED TO BE DEMOLISHED SHALL BE REMOVED IN THEIR ENTIRETY, INCLUDING INSTALLATIONS ABOVE THE CEILING. EXISTING WALLS SHALL BE PATCHED WHERE ITEMS WERE REMOVED TO MATCH ADJACENT SURFACES.
- DUST BARRIERS SHALL BE CONSTRUCTED AND MAINTAINED THROUGH THE COURSE OF CONSTRUCTION TO MINIMIZE THE SPREAD OF CONSTRUCTION DUST.
- PROTECT EXISTING WALLS TO REMAIN. ALL EXISTING WALLS TO REMAIN TO BE FINISHED TO ACHIEVE 'AS NEW' APPEARANCE.
- CONTRACTOR TO PROTECT OR REMOVE CEILING TILE AS REQUIRED IN AREAS WHERE EQUIPMENT IS BEING INSTALLED.
- PATCH EXISTING CEILINGS AS REQUIRED DUE TO INSTALLATION OF OVERHEAD EQUIPMENT.
- REMOVE EXISTING LIGHTING AS SCHEDULED. EXISTING FIRE SPRINKLER HEADS TO BE LEFT INTACT.

**SYMBOL LEGEND:**

- EXISTING WALL TO REMAIN
- EXISTING WINDOW TO REMAIN
- EXISTING DOOR TO REMAIN

**PLAN NOTES:**

- CONTRACTORS TO VERIFY ALL FIELD CONDITIONS PRIOR TO COMMENCEMENT AND REPORT ANY DISCREPANCIES TO THE ARCHITECT
- ALL PENETRATIONS, NEW AND EXISTING THROUGH RATED PARTITIONS MUST MEET UL APPROVED STANDARDS - SUBMIT SYSTEM TO ARCHITECT FOR APPROVAL. FIELD VERIFY PRIOR TO BID.
- PROVIDE SOLID WOOD BACKING FOR ALL WALLS TO RECEIVE COUNTERS, CABINETS, DOOR STOPS, SINKS, TOILET ACCESSORIES, CHAIR RAILS, AND OTHER RELATED INSTALLATIONS. THE INSTALLATIONS SHALL BE INSPECTED BY THE ARCHITECT PRIOR TO COVERING WITH DRYWALL.
- THE NOTE HOLD ON DIMENSION STRINGS INDICATE MINIMUM CLEAR FINISH DIMENSIONS.
- PENETRATIONS THROUGH FIRE RATED PARTITIONS WILL BE FIRE CAULKED WITH THE UL SYSTEM NO. W-L-1044.

**FINISH NOTES:**

- ALL FINISHES SHALL MEET THE REQUIREMENTS OF NCBC 2010 CHAPTER 8, TABLE 803.11:
  - VERTICAL EXITS AND EXIT PASSAGEWAYS - CLASS B
  - EXIT ACCESS CORRIDORS AND OTHER EXIT WAYS - CLASS C
  - ROOMS AND ENCLOSED SPACES - CLASS C
- ALL FINISHES TO BE APPROVED BY TENANT PRIOR TO INSTALLATION.
- PROVIDE APPROPRIATE HANDICAP ACCESSIBLE THRESHOLDS WHERE FLOOR CHANGES MATERIAL.
- SEE FINISH SCHEDULE FOR PLASTIC LAMINATE COLORS.
- ALL EXISTING DRYWALL WALLS WITHIN THE SCOPE AREA SHALL BE PAINTED W/ TWO COATS FLAT FINISH LATEX PAINT AS REQUIRED TO COVER. ALL WALLS SHALL THEN BE PAINTED WITH ONE COLOR, ONE COAT, SEE FINISH SCHEDULE FOR COLORS.
- THE EXISTING DOORS SHALL BE REFINISHED TO MATCH THE EXISTING ADJACENT.
- PROVIDE MINIMUM CLASS II FLOOR FINISH MATERIALS TO COMPLY WITH MINIMUM CRITICAL RADIANT FLUX IN EXIT PASSAGEWAYS AND CORRIDORS. ALL OTHER AREAS MUST COMPLY WITH THE DOC FF-1 'PULL-TEST' (FPC 16 CFR, PART 1630)
- PAINT NEW EXPOSED ELECTRICAL CABLE DUCTING AND CONDUIT, COLOR TO MATCH WALLS.
- PAINT DOOR AND WINDOW FRAMES WITH TWO COATS SEMI GLOSS LATEX PAINT.

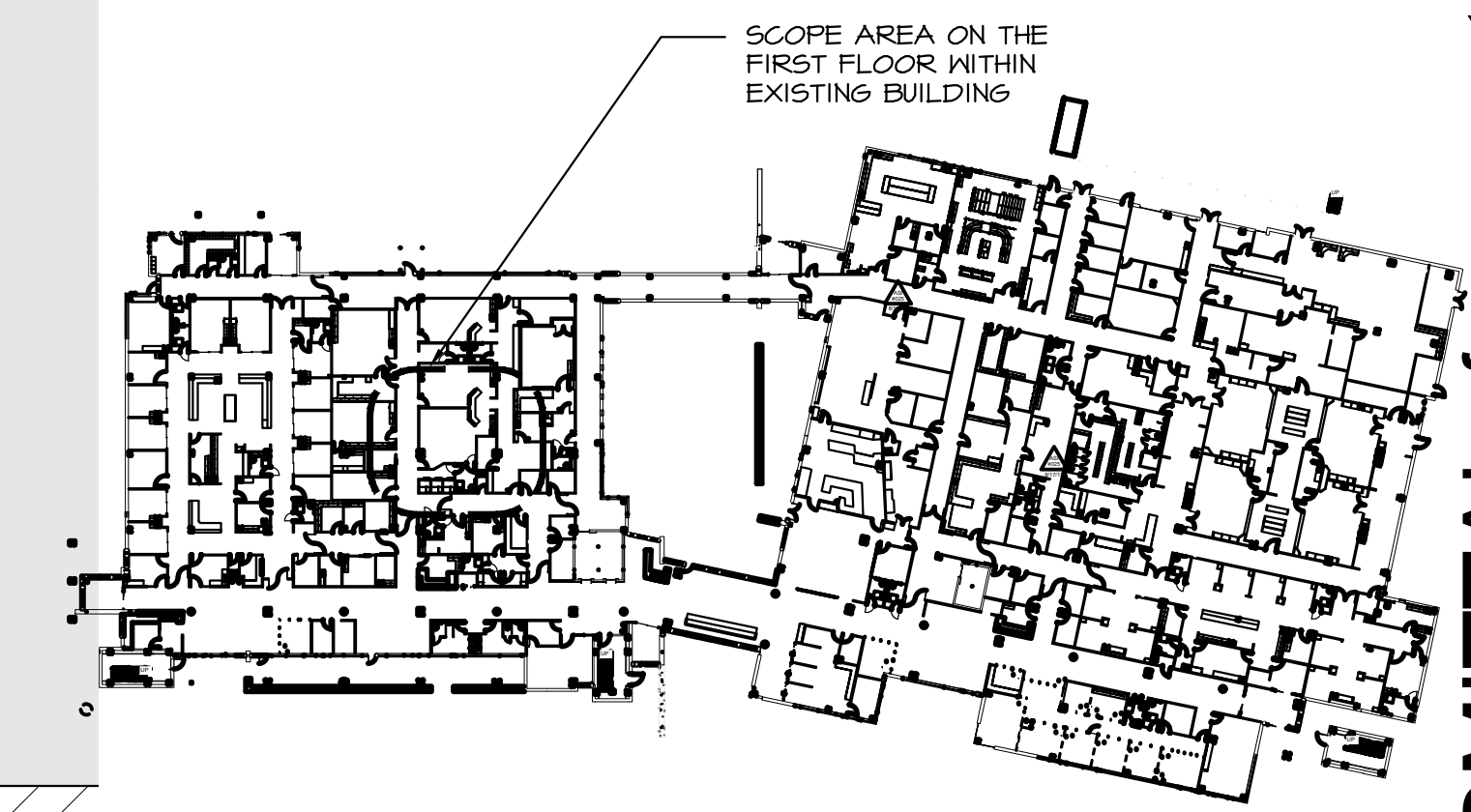
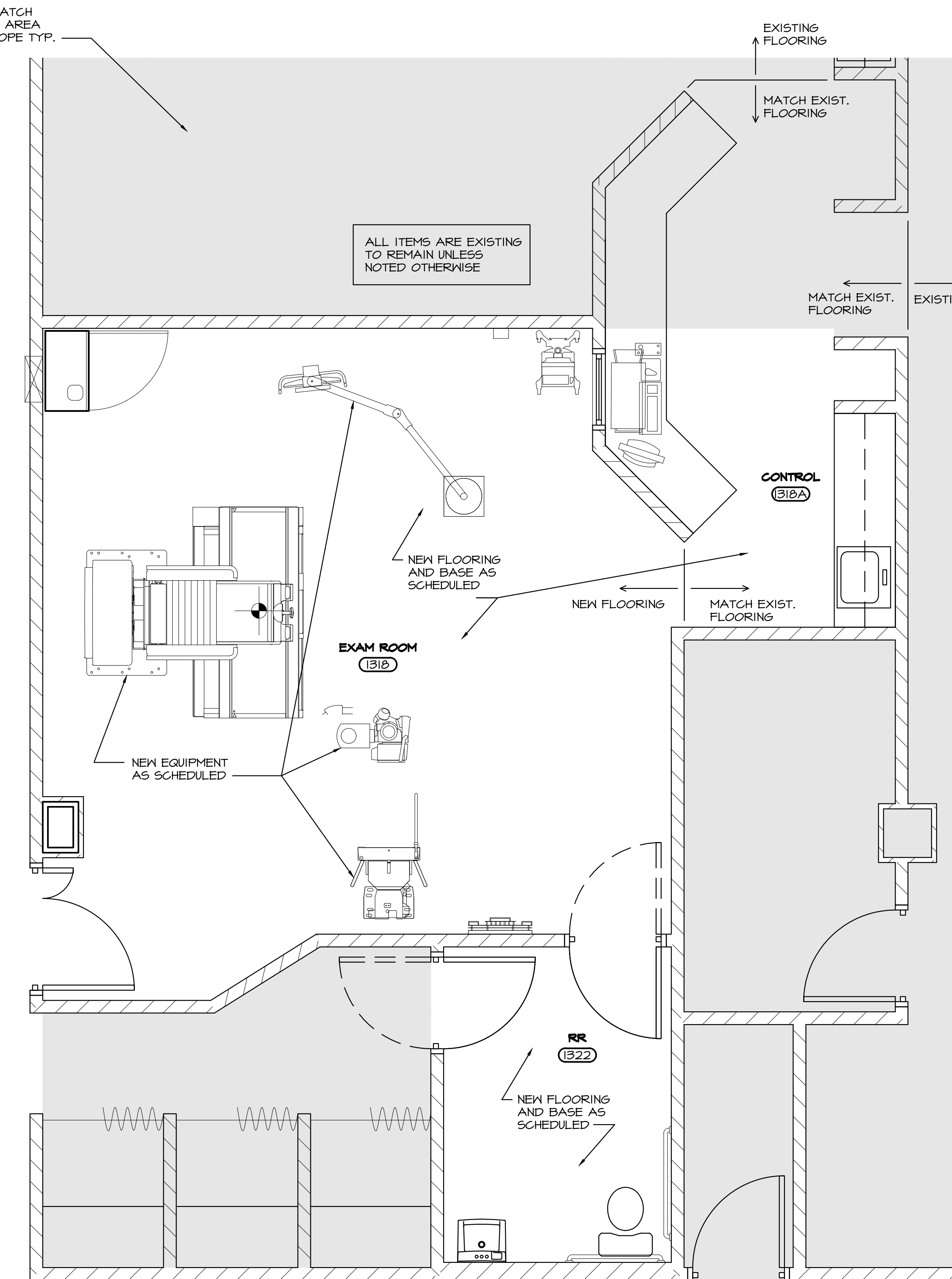
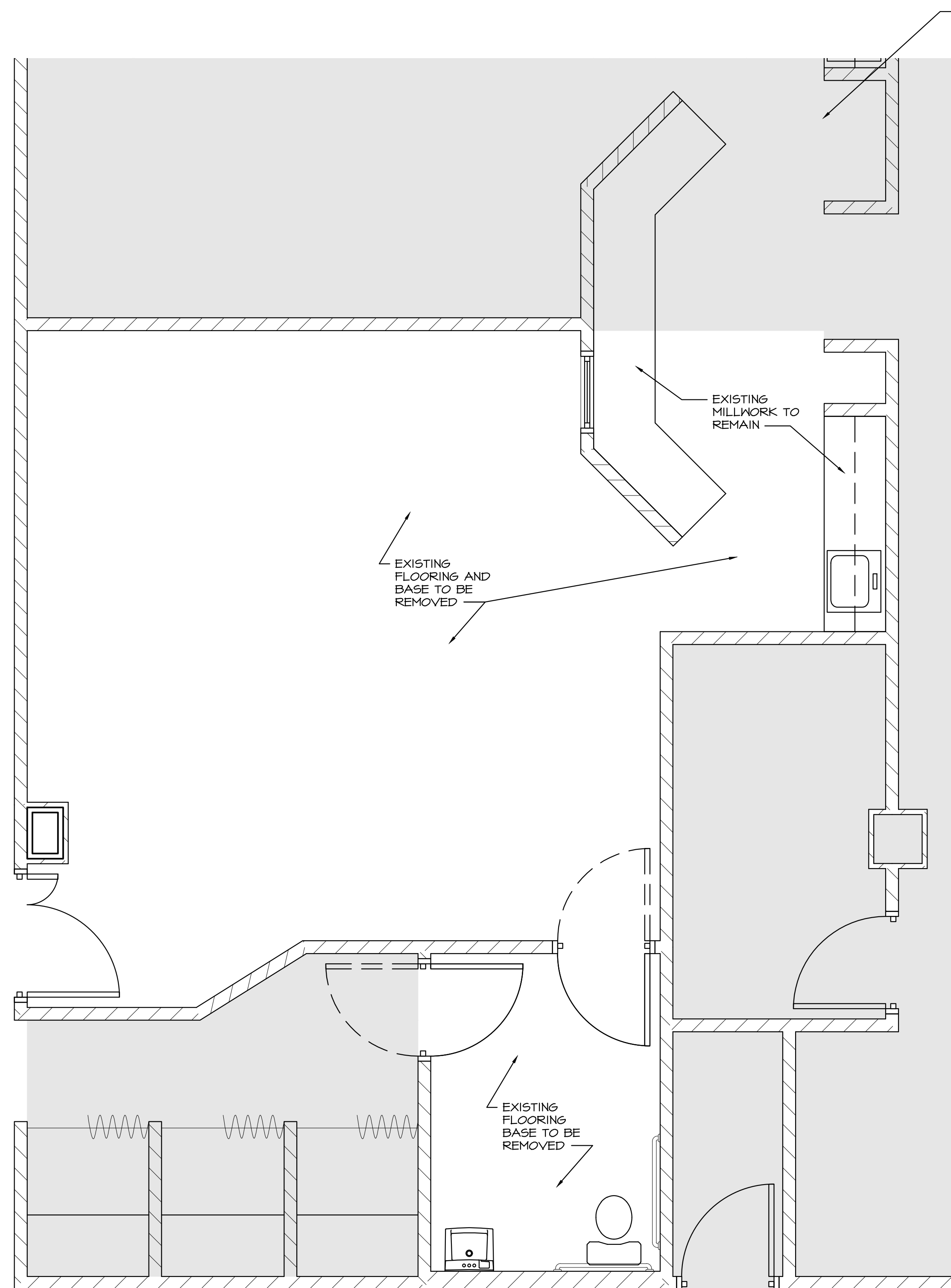

**DEMOLITION PLAN**  
3/8"=1'-0"

**FIRST FLOOR PLAN**  
3/8"=1'-0"

**OVERALL FIRST FLOOR PLAN**  
NTS

**C.D. HAIR ARCHITECT**  
8401 Lake Worth Road  
Suite 119  
Lake Worth, FL  
15034

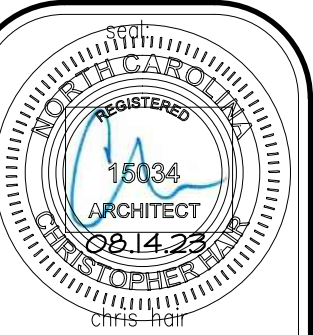

An Interior Renovation for:  
**Harnett Health  
RAD Room 1318 Renovation**  
215 Brighthwater Drive  
Lillington, North Carolina





**FINAL SUBMITTAL for construction**

job no. 23-016  
principal: CHRIS HAIR  
CH  
file name:  
date: 08.10.23  
title: DEMO AND FLOOR PLAN



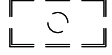

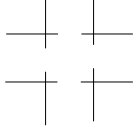
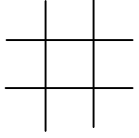
**A210**  
5 A



**CEILING DEMOLITION LEGEND:**

-  EXISTING LIGHT FIXTURE TO BE REMOVED
-  EXISTING LIGHT FIXTURE TO BE SALVAGED FOR REINSTALLATION
-  EXISTING SUPPLY REGISTER TO BE SALVAGED FOR REINSTALLATION
-  EXISTING RETURN REGISTER TO BE SALVAGED FOR REINSTALLATION
-  EXISTING ACOUSTICAL CEILING AND GRID TO BE REMOVED
-  EXISTING CEILING AND INSTALLATIONS TO REMAIN
-  EXISTING FIRE SPRINKLER HEAD TO BE SALVAGED FOR REINSTALLATION

**CEILING LEGEND:**

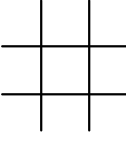
-  EXISTING REINSTALLED 2' x 4' LED LIGHT FIXTURE
  -  NEW 6" RECESSED DIMMABLE LED CAN LIGHT FIXTURE
  -  EXISTING REINSTALLED SUPPLY REGISTER
  -  EXISTING REINSTALLED RETURN REGISTER
  -  EXISTING REINSTALLED FIRE SPRINKLER HEAD
  -  NEW 2 X 2 CEILING IN NEW GRID - PROVIDE TILE AS SPECIFIED
- D = DIMMABLE

**CEILING NOTES:**

1. ALL CEILING MOUNTED ITEMS, INCLUDING LIGHTS, AND HVAC REGISTERS, SHALL BE CENTERED IN THE TILE. ANY CONFLICTS SHALL BE REPORTED TO THE ARCHITECT UPON DISCOVERY. UNDER NO CIRCUMSTANCES SHALL ANY ITEM BE RELOCATED WITHOUT THE ARCHITECT'S APPROVAL.
2. ALL RECTANGULAR ROOMS SHALL HAVE EQUAL BORDERS UNLESS NOTED OTHERWISE. SEE THE PLANS FOR DENOTED STARTING POINTS AND POINTS OF ALIGNMENT.
3. ALL CEILING HEIGHTS FOR SUSPENDED CEILINGS ARE INDICATED ON THE CEILING PLAN.
4. ALL NEW CEILING GRID SHALL BE ATTACHED TO THE ROOF / FLOOR JOISTS ABOVE AT 4'-0" O.C. (MAX) WITH ASTM A641, CLASS 1 ZINC COATED, SOFT TEMPER, PRE-STRETCHED HANGER WIRE (12 GA) MINIMUM. ALL HANGER WIRE SHALL BE INSTALLED PLUMB AND STRAIGHT. GRID SUSPENSION SYSTEM TO MEET ASTM 635-636.

**C.D. HAIR ARCHITECT**  
 8401 Lake Worth Road  
 Suite 119  
 Lake Worth, FL  
**15034**

revision:

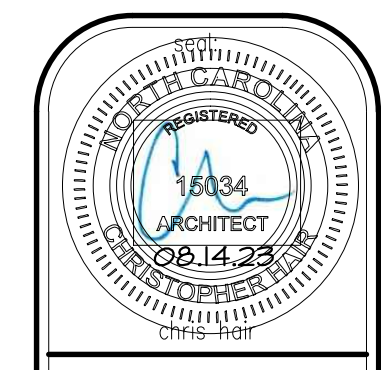



An Interior Renovation for:  
**Harnett Health**  
**RAD Room 1318 Renovation**  
 215 Brighthwater Drive  
 Lillington, North Carolina

FINAL SUBMITTAL for construction

job no. **23-016**  
 principal: **CHRIS HAIR**  
 CH  
 file name:  
 date: **08.10.23**  
 title: **DEMO AND REFLECTED CEILING PLAN**

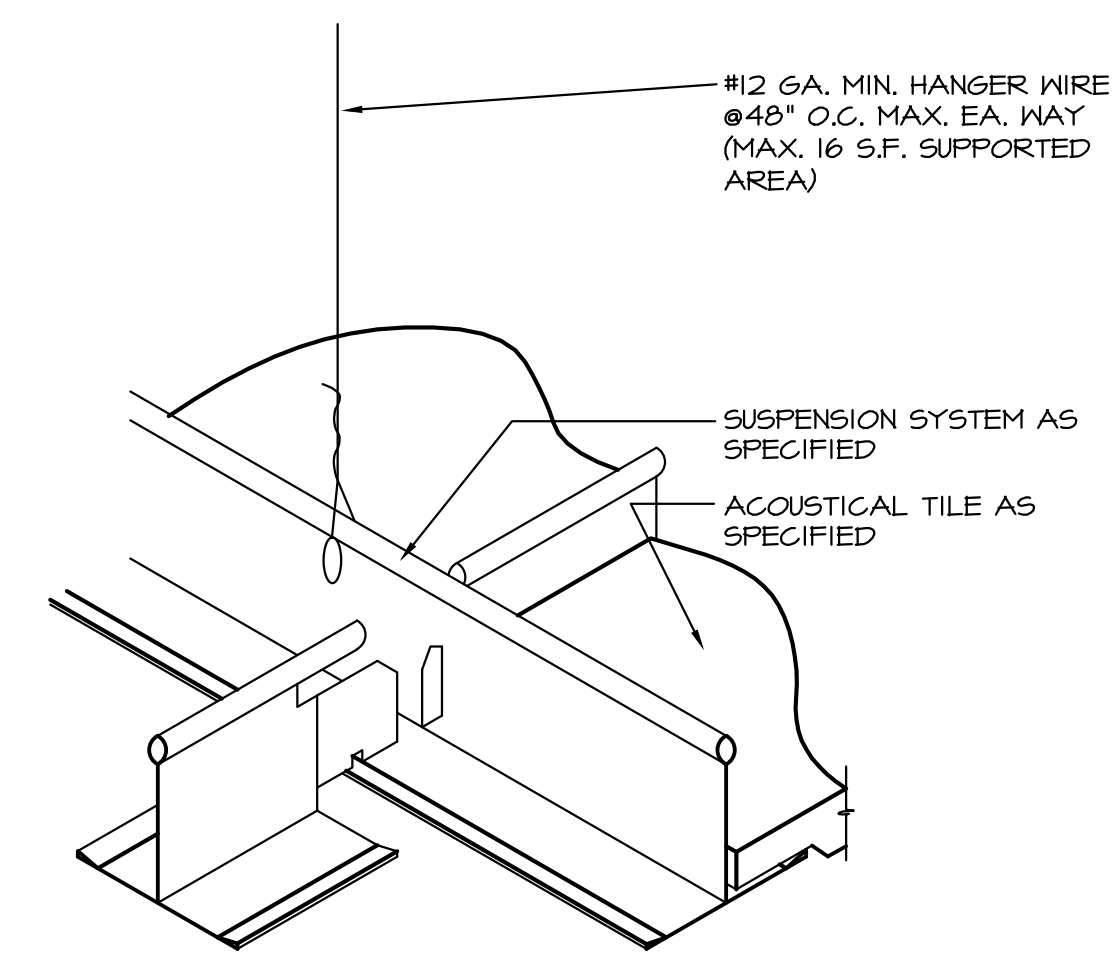
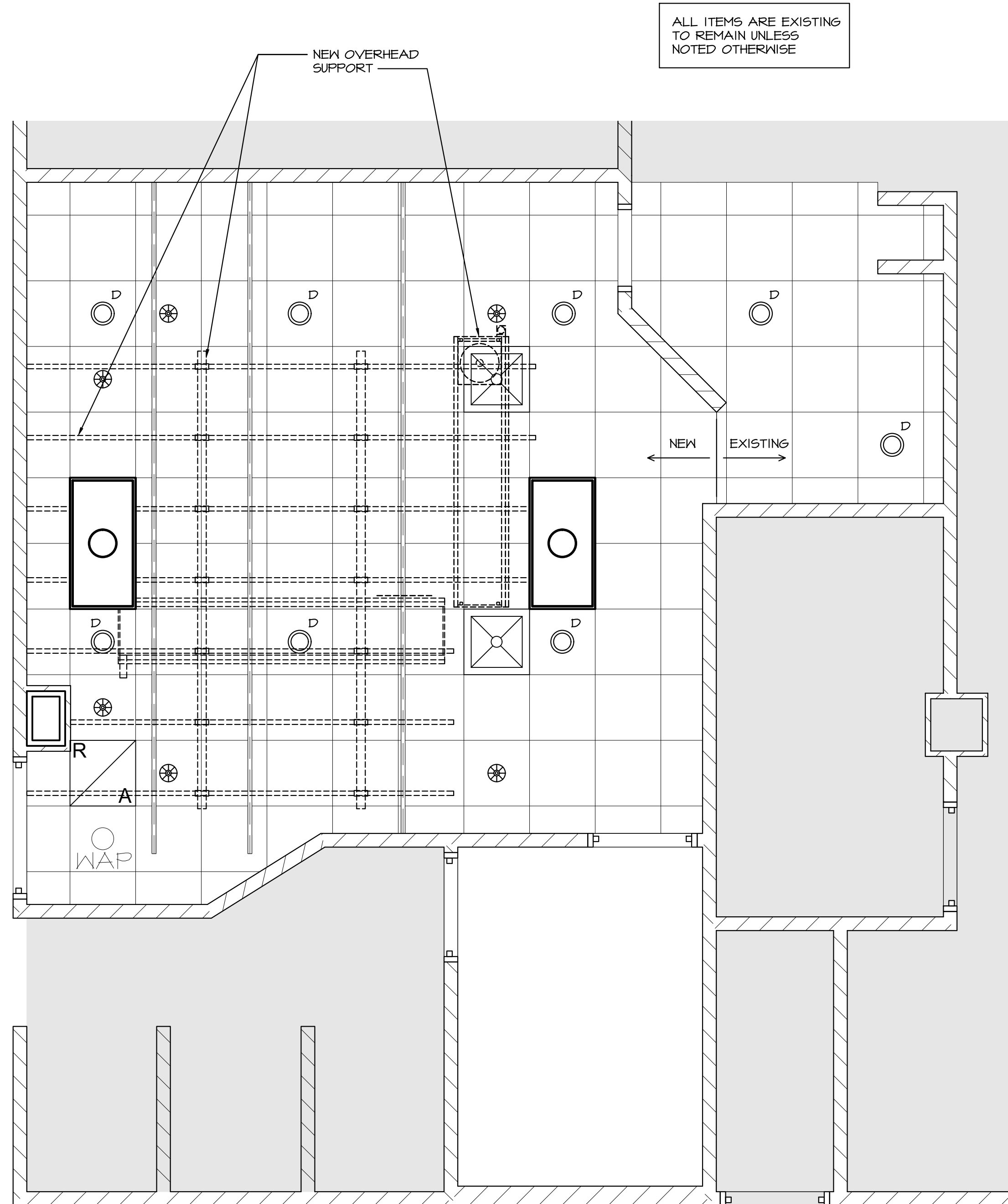
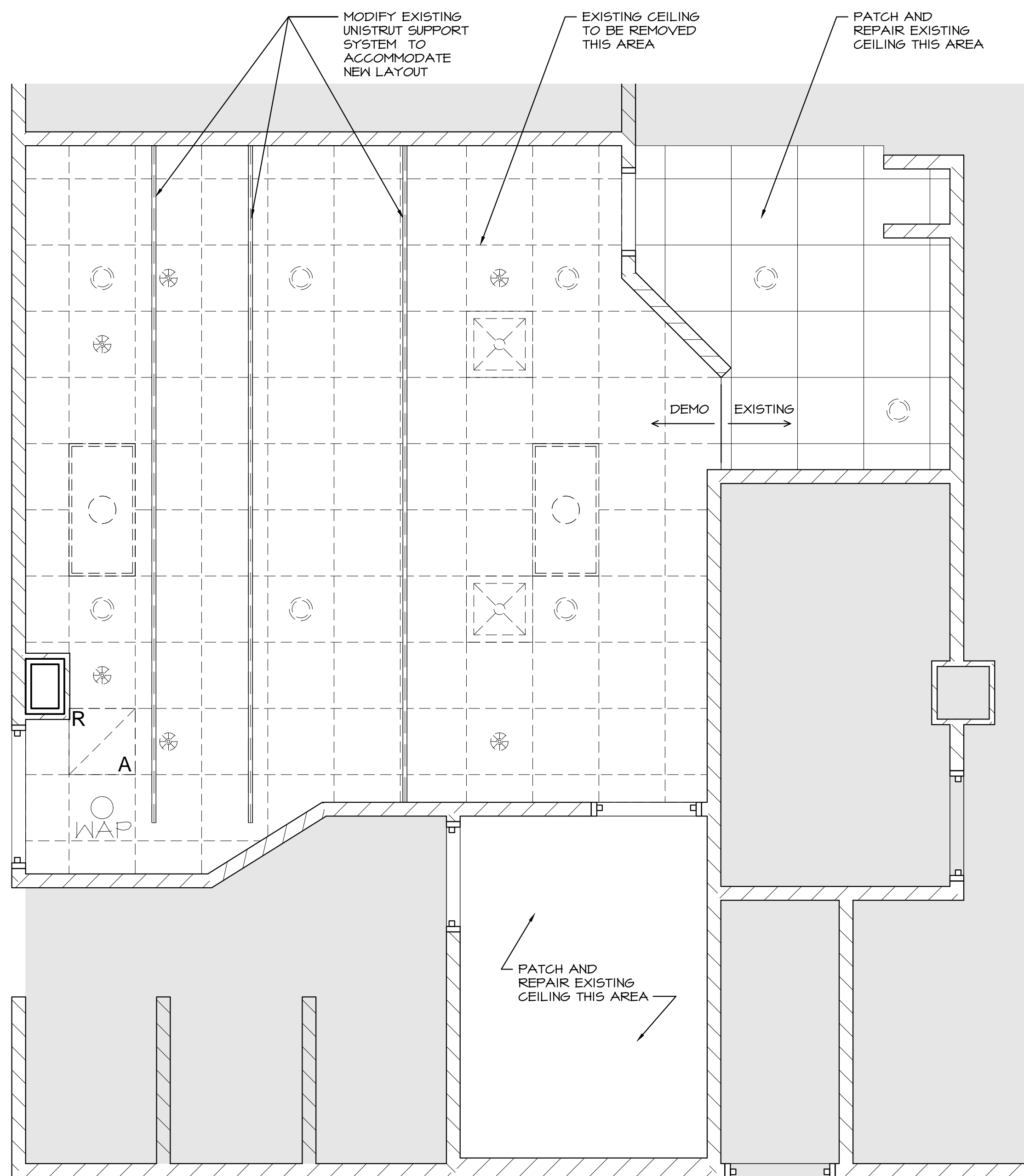
**A410**  
 5 A



**DEMOLITION CEILING PLAN**  
 3/8" = 1'-0"

**REFLECTED CEILING PLAN**  
 3/8" = 1'-0"

**CEILING GRID DETAIL**  
 3" = 1'-0"

FINAL SUBMITTAL for construction

**ICRA PLAN NOTES**

1. THE GENERAL CONTRACTOR SHALL BECOME FAMILIAR WITH THE PROJECT SITE AND NOTIFY THE ARCHITECT IMMEDIATELY OF DISCREPANCIES.

**PLAN KEYNOTES**

1. PRIOR TO CONSTRUCTION, SEAL OFF APPLICABLE SITE SUPPLY AND RETURN AIR DIFFUSERS AND GRILLES TO MINIMIZE DUST CONTAMINATION OF DUCTWORK AND SURROUNDING AREAS. PROVIDE NEGATIVE PRESSURE WITHIN THE PROJECT AREA RELATIVE TO THE AREAS SURROUNDING THE PROJECT AREA AS WELL AS HEPA AIR FILTRATION. PROVIDE MEANS OF MONITORING THE AIR PRESSURE FOR THE ENTIRE DURATION OF CONSTRUCTION.
2. SEAL EXISTING AREA WITH FIRE RETARDANT VISQUEEN ABOVE THE CEILING. TAPE PERIMETER SUCH THAT AN AIR TIGHT BARRIER IS ACHIEVED.
3. PROVIDE WALK-OFF MAT
4. PROVIDE TEMPORARY ZIPWALL CONTAINMENT BARRIER

**ICRA CLASSIFICATION DATA**

CONSTRUCTION TYPE: I-B  
 CONSTRUCTION CLASS: II  
 RISK CLASS: MEDIUM

CONSTRUCTION PROTOCOLS

DURING CONSTRUCTION	UPON COMPLETION
1. SEAL SITE SUPPLY AND RETURN AIR DIFFUSERS.	1. DO NOT REMOVE BARRIERS FROM WORK AREA UNTIL COMPLETED PROJECT IS INSPECTED BY THE OWNERS SAFETY DEPARTMENT AND INFECTION CONTROL DEPARTMENT AND THOROUGHLY CLEANED BY THE OWNERS ENVIRONMENTAL SERVICES DEPARTMENT.
2. INSTALL TEMPORARY ZIPWALL BARRIER AS SHOWN ON DETAIL 1, THIS SHEET.	2. REMOVE BARRIER MATERIALS CAREFULLY TO MINIMIZE SPREADING OF DIRT AND DEBRIS ASSOCIATED WITH CONSTRUCTION.
3. PROVIDE A TEMPORARY NEGATIVE AIR UNIT WITH HEPA FILTRATION TO PLACE PROJECT SITE AT NEGATIVE PRESSURE.	3. VACUUM WORK AREA WITH HEPA FILTERED VACUUMS.
4. PROVIDE SHOE COVERS AND TEMPORARY WALK OFF ADHESIVE MATS AT EXIT OF PROJECT AREA.	4. WET MOP AREA WITH DISINFECTANT.
5. CONTAIN CONSTRUCTION WASTE BEFORE TRANSPORT IN TIGHTLY COVERED CONTAINERS.	5. REMOVE ISOLATION OF HVAC SYSTEM IN AREAS WHERE WORK IS BEING PERFORMED.

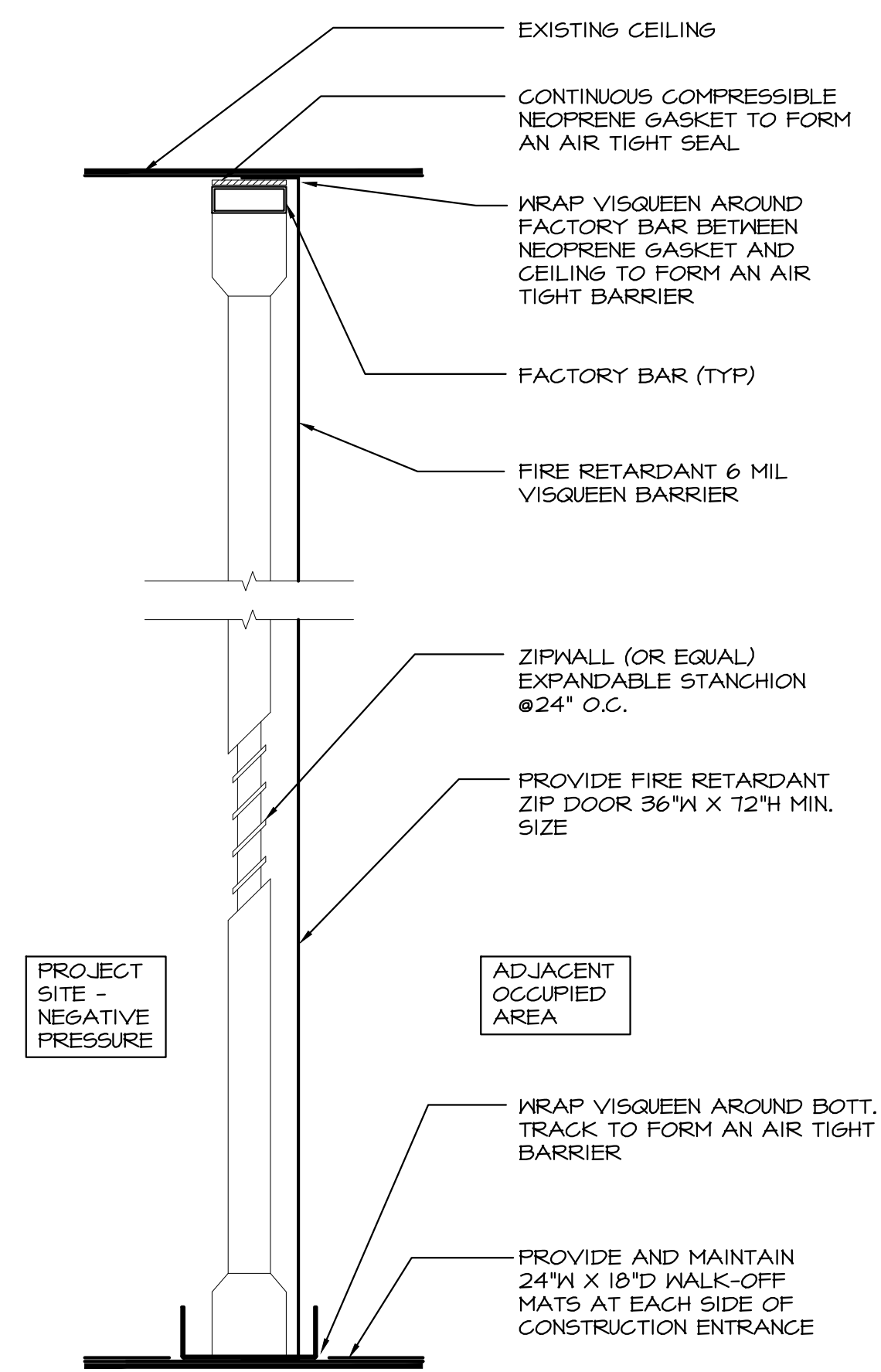

**TEMPORARY ZIPWALL CONTAINMENT BARRIER**  
 3" = 1'-0" A910

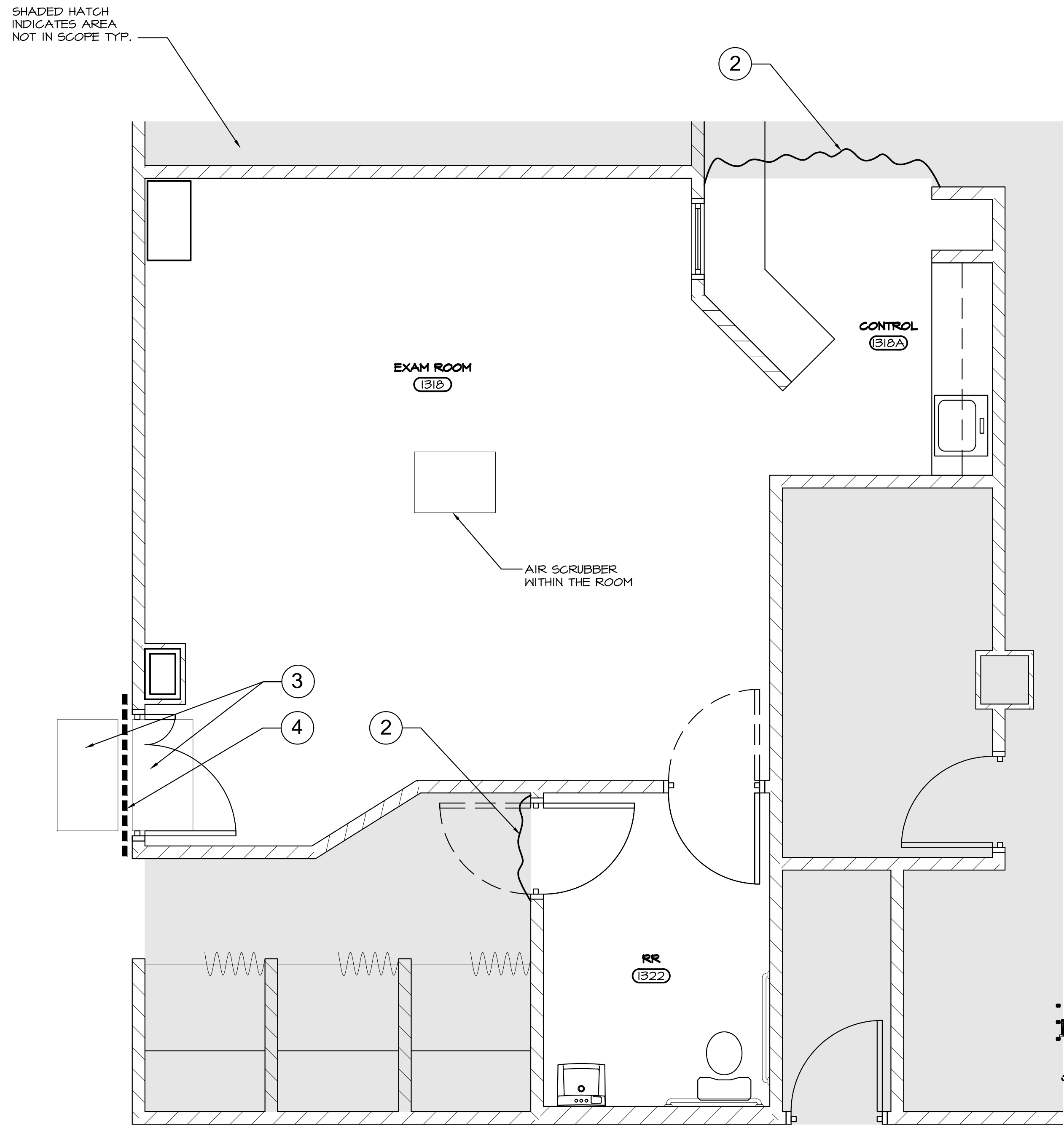

**ICRA COORDINATION PLAN**  
 3/8" = 1'-0"

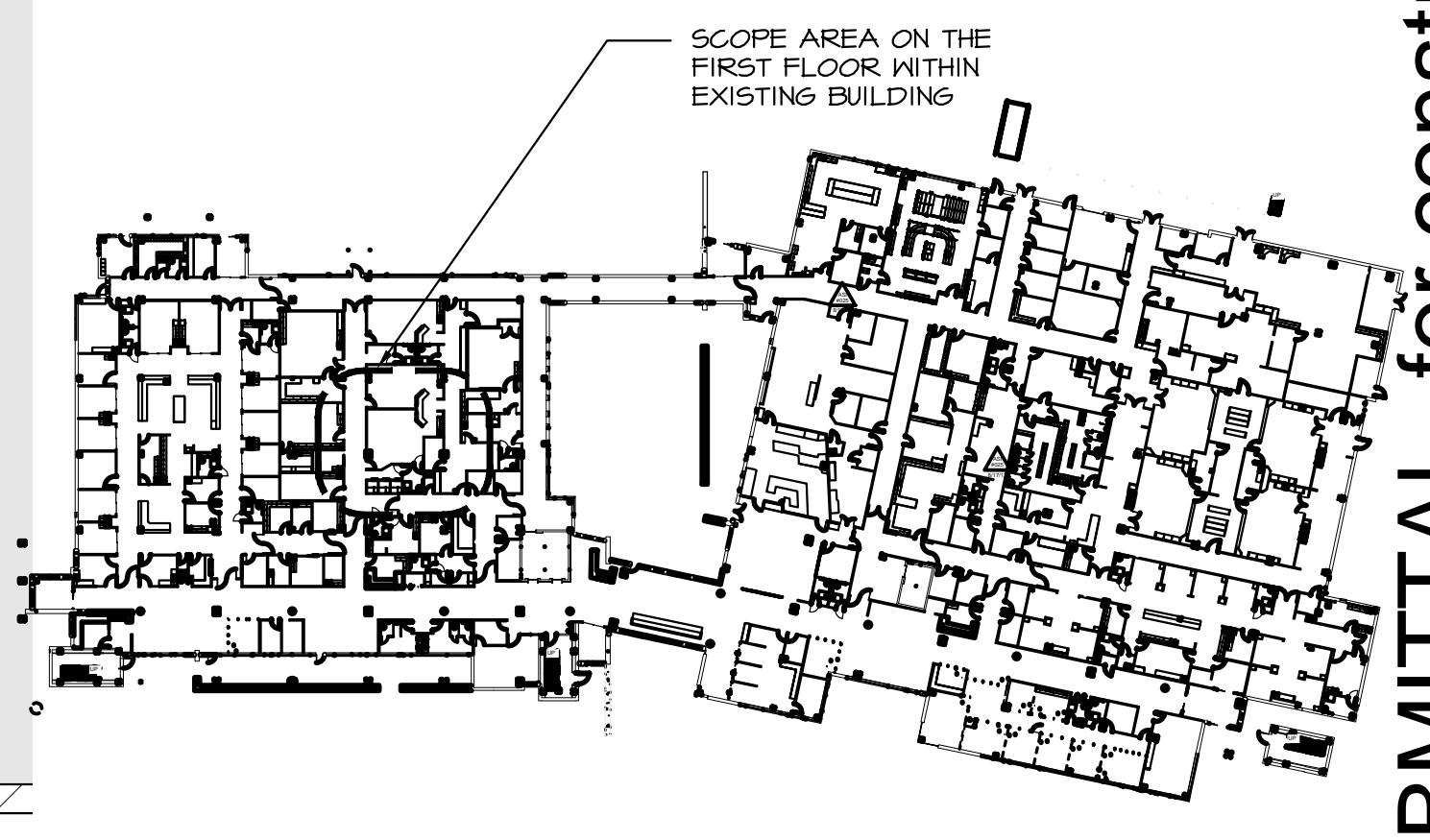

**OVERALL FIRST FLOOR PLAN**  
 NTS

**FINAL SUBMITTAL for construction**

**2018 APPENDIX B**  
**BUILDING CODE SUMMARY FOR ALL COMMERCIAL PROJECTS**  
**(EXCEPT 1 AND 2-FAMILY DWELLINGS AND TOWNHOUSES)**

(Reproduce the following data on the building plans sheet 1 or 2)

Name of Project: Cape Fear Valley Medical Center - Harnett Health Rad Rm Replacement  
 Address: 215 Brightwater Drive, Lillington, North Carolina Zip Code 27546  
 Owner/Authorized Agent: Bruce Dantzer Phone # ( 910 ) 615 - 4393 E-Mail BDANT@capefearvalley.com  
 Owned By:  City/County  Private  State  
 Code Enforcement Jurisdiction:  City \_\_\_\_\_  County Harnett  State

**CONTACT:**

DESIGNER	FIRM	NAME	LICENSE #	TELEPHONE #	E-MAIL
Architectural	<u>CD Hair Architect, LLC</u>	<u>Chris Hair R.A.</u>	<u>15034</u>	<u>(561) 209-6050</u>	<u>chris@cdhairarchitect.com</u>
Civil	<u>N/A</u>			<u>( )</u>	
Electrical	<u>TYEC Engineers</u>	<u>Andy Youngross PE</u>	<u>048609</u>	<u>(561) 274.0200</u>	<u>andrew@tecfla.com</u>
Fire Alarm	<u>N/A</u>			<u>( )</u>	
Plumbing	<u>N/A</u>			<u>( )</u>	
Mechanical	<u>TYEC Engineers</u>	<u>Andy Youngross PE</u>	<u>048609</u>	<u>(561) 274.0200</u>	<u>andrew@tecfla.com</u>
Sprinkler-Standpipe	<u>N/A</u>			<u>( )</u>	
Structural	<u>N/A</u>			<u>( )</u>	
Retaining Walls >5' High	<u>N/A</u>			<u>( )</u>	
Other	<u>N/A</u>			<u>( )</u>	

("Other" should include firms and individuals such as truss, precast, pre-engineered, interior designers, etc.)

**2018 NC BUILDING CODE:**  New Building  Addition  Renovation  
 1<sup>st</sup> Time Interior Completion  
 Shell/Core - Contact the local inspection jurisdiction for possible additional procedures and requirements  
 Phased Construction - Shell/Core- Contact the local inspection jurisdiction for possible additional procedures and requirements

**2018 NC EXISTING BUILDING CODE: EXISTING:**  Prescriptive  Repair  Chapter 14  
 Alteration:  Level I  Level II  Level III  
 Historic Property  Change of Use

**CONSTRUCTED:** (date) 2010 **CURRENT OCCUPANCY(S) (Ch. 3):** I-2, Condition 2  
**RENOVATED:** (date) Several **PROPOSED OCCUPANCY(S) (Ch. 3):** I-2, Condition 2

**RISK CATEGORY (Table 1604.5):** **Current:**  I  II  III  IV  
**Proposed:**  I  II  III  IV

**BASIC BUILDING DATA**

**Construction Type:**  I-A  II-A  III-A  IV  V-A  
 (check all that apply)  I-B  II-B  III-B  V-B  
**Sprinklers:**  No  Partial  Yes  NFPA 13  NFPA 13R  NFPA 13D  
**Standpipes:**  No  Yes Class  I  II  III  Wet  Dry  
**Fire District:**  No  Yes **Flood Hazard Area:**  No  Yes  
**Special Inspections Required:**  No  Yes (Contact the local inspection jurisdiction for additional procedures and requirements.)

**Gross Building Area Table**

FLOOR	EXISTING (SQ FT)	NEW (SQ FT)	SUB-TOTAL
3 <sup>rd</sup> Floor			
2 <sup>nd</sup> Floor			
Mezzanine			
1 <sup>st</sup> Floor	<b>EXISTING TO REMAIN</b>		
Basement			
TOTAL	AREA OF RENOVATION:	<b>574 SF</b>	

**ALLOWABLE AREA**

**Primary Occupancy Classification(s):**

- Assembly  A-1  A-2  A-3  A-4  A-5
- Business
- Educational
- Factory  F-1 Moderate  F-2 Low
- Hazardous  H-1 Detonate  H-2 Deflagrate  H-3 Combust  H-4 Health  H-5 HPM
- Institutional  I-1 Condition  1  2  
 I-2 Condition  1  2  
 I-3 Condition  1  2  3  4  5  
 I-4
- Mercantile
- Residential  R-1  R-2  R-3  R-4
- Storage  S-1 Moderate  S-2 Low  High-piled  
 Parking Garage  Open  Enclosed  Repair Garage
- Utility and Miscellaneous

**Accessory Occupancy Classification(s):** NONE

**Incidental Uses (Table 509):** NONE

**Special Uses (Chapter 4 – List Code Sections):** 407

**Special Provisions: (Chapter 5 – List Code Sections):** NONE

**Mixed Occupancy:**  No  Yes Separation: \_\_\_\_\_ Hr. Exception: \_\_\_\_\_

Non-Separated Use (508.3) - The required type of construction for the building shall be determined by applying the height and area limitations for each of the applicable occupancies to the entire building. The most restrictive type of construction, so determined, shall apply to the entire building.

Separated Use (508.4) - See below for area calculations for each story, the area of the occupancy shall be such that the sum of the ratios of the actual floor area of each use divided by the allowable floor area for each use shall not exceed 1.

$$\frac{\text{Actual Area of Occupancy A}}{\text{Allowable Area of Occupancy A}} + \frac{\text{Actual Area of Occupancy B}}{\text{Allowable Area of Occupancy B}} \leq 1$$

$$\underline{\hspace{2cm}} + \underline{\hspace{2cm}} + \dots = \underline{\hspace{2cm}} \leq 1.00$$

STORY NO.	DESCRIPTION AND USE	(A) BLDG AREA PER STORY (ACTUAL)	(B) TABLE 506.2 <sup>4</sup> AREA	(C) AREA FOR FRONTAGE INCREASE <sup>1,5</sup>	(D) ALLOWABLE AREA PER STORY OR UNLIMITED <sup>2,3</sup>
		<b>EXISTING TO REMAIN</b>			

<sup>1</sup> Frontage area increases from Section 506.3 are computed thus:

- a. Perimeter which fronts a public way or open space having 20 feet minimum width = \_\_\_\_\_ (F)
- b. Total Building Perimeter = \_\_\_\_\_ (P)
- c. Ratio (F/P) = \_\_\_\_\_ (F/P)
- d. W = Minimum width of public way = \_\_\_\_\_ (W)
- e. Percent of frontage increase  $I_f = 100[F/P - 0.25] \times W/30 =$  \_\_\_\_\_ (%)

<sup>2</sup> Unlimited area applicable under conditions of Section 507.

<sup>3</sup> Maximum Building Area = total number of stories in the building x D (maximum 3 stories) (506.2).

<sup>4</sup> The maximum area of open parking garages must comply with Table 406.5.4.

<sup>5</sup> Frontage increase is based on the unsprinklered area value in Table 506.2.

### ALLOWABLE HEIGHT

	ALLOWABLE	SHOWN ON PLANS	CODE REFERENCE <sup>1</sup>
Building Height in Feet (Table 504.3) <sup>2</sup>			
Building Height in Stories (Table 504.4) <sup>3</sup>		<b>EXISTING TO REMAIN</b>	

<sup>1</sup> Provide code reference if the "Shown on Plans" quantity is not based on Table 504.3 or 504.4.

<sup>2</sup> The maximum height of air traffic control towers must comply with Table 412.3.1.

<sup>3</sup> The maximum height of open parking garages must comply with Table 406.5.4.

## FIRE PROTECTION REQUIREMENTS

BUILDING ELEMENT	FIRE SEPARATION DISTANCE (FEET)	RATING		DETAIL # AND SHEET #	DESIGN # FOR RATED ASSEMBLY	SHEET # FOR RATED PENETRATION	SHEET # FOR RATED JOINTS
		REQ'D	PROVIDED (w/ <u>          </u> * REDUCTION)				
Structural Frame, including columns, girders, trusses							
Bearing Walls							
Exterior							
North							
East							
West							
South							
Interior							
Nonbearing Walls and Partitions		EXISTING TO REMAIN					
Exterior walls							
North							
East							
West							
South							
Interior walls and partitions							
Floor Construction							
Including supporting beams and joists							
Floor Ceiling Assembly							
Columns Supporting Floors							
Roof Construction, including supporting beams and joists							
Roof Ceiling Assembly							
Columns Supporting Roof							
Shaft Enclosures - Exit							
Shaft Enclosures - Other							
Corridor Separation							
Occupancy/Fire Barrier Separation							
Party/Fire Wall Separation							
Smoke Barrier Separation							
Smoke Partition							
Tenant/Dwelling Unit/Sleeping Unit Separation							
Incidental Use Separation							

\* Indicate section number permitting reduction

**PERCENTAGE OF WALL OPENING CALCULATIONS**

FIRE SEPARATION DISTANCE (FEET) FROM PROPERTY LINES	DEGREE OF OPENINGS PROTECTION (TABLE 705.8)	ALLOWABLE AREA (%)	ACTUAL SHOWN ON PLANS (%)
<b>EXISTING TO REMAIN</b>			

**LIFE SAFETY SYSTEM REQUIREMENTS**

- Emergency Lighting:       No  Yes
- Exit Signs:                 No  Yes
- Fire Alarm:                 No  Yes
- Smoke Detection Systems:  No  Yes  Partial \_\_\_\_\_
- Carbon Monoxide Detection:  No  Yes

**LIFE SAFETY PLAN REQUIREMENTS**

Life Safety Plan Sheet #:           Sheet A010                **EXISTING TO REMAIN**

- Fire and/or smoke rated wall locations (Chapter 7)
- Assumed and real property line locations (if not on the site plan)
- Exterior wall opening area with respect to distance to assumed property lines (705.8)
- Occupancy Use for each area as it relates to occupant load calculation (Table 1004.1.2)
- Occupant loads for each area
- Exit access travel distances (1017)
- Common path of travel distances (Tables 1006.2.1 & 1006.3.2(1))
- Dead end lengths (1020.4)
- Clear exit widths for each exit door
- Maximum calculated occupant load capacity each exit door can accommodate based on egress width (1005.3)
- Actual occupant load for each exit door
- A separate schematic plan indicating where fire rated floor/ceiling and/or roof structure is provided for purposes of occupancy separation
- Location of doors with panic hardware (1010.1.10)
- Location of doors with delayed egress locks and the amount of delay (1010.1.9.7)
- Location of doors with electromagnetic egress locks (1010.1.9.9)
- Location of doors equipped with hold-open devices
- Location of emergency escape windows (1030)
- The square footage of each fire area (202)
- The square footage of each smoke compartment for Occupancy Classification I-2 (407.5)
- Note any code exceptions or table notes that may have been utilized regarding the items above

**ACCESSIBLE DWELLING UNITS  
(SECTION 1107)**

**N/A**

TOTAL UNITS	ACCESSIBLE UNITS REQUIRED	ACCESSIBLE UNITS PROVIDED	TYPE A UNITS REQUIRED	TYPE A UNITS PROVIDED	TYPE B UNITS REQUIRED	TYPE B UNITS PROVIDED	TOTAL ACCESSIBLE UNITS PROVIDED

**ACCESSIBLE PARKING  
(SECTION 1106)**

**EXISTING TO REMAIN**

LOT OR PARKING AREA	TOTAL # OF PARKING SPACES		# OF ACCESSIBLE SPACES PROVIDED			TOTAL # ACCESSIBLE PROVIDED
	REQUIRED	PROVIDED	REGULAR WITH 5' ACCESS AISLE	VAN SPACES WITH		
				132" ACCESS AISLE	8' ACCESS AISLE	
TOTAL						

**PLUMBING FIXTURE REQUIREMENTS  
(TABLE 2902.1)**

**EXISTING TO REMAIN**

USE		WATERCLOSETS			URINALS	LAVATORIES			SHOWERS /TUBS	DRINKING FOUNTAINS	
		MALE	FEMALE	UNISEX		MALE	FEMALE	UNISEX		REGULAR	ACCESSIBLE
SPACE	EXIST'G										
	NEW										
	REQ'D										

**SPECIAL APPROVALS**

**Special approval:** (Local Jurisdiction, Department of Insurance, OSC, DPI, DHHS, etc., describe below)

DHSR Approval Required

---



---



---

---

**ENERGY SUMMARY**    **EXISTING TO REMAIN**

**ENERGY REQUIREMENTS:**

The following data shall be considered minimum and any special attribute required to meet the energy code shall also be provided. Each Designer shall furnish the required portions of the project information for the plan data sheet. If performance method, state the annual energy cost for the standard reference design vs annual energy cost for the proposed design.

**Existing building envelope complies with code:**     No     Yes (The remainder of this section is not applicable)

**Exempt Building:**     No     Yes (Provide code or statutory reference): \_\_\_\_\_

**Climate Zone:**     3A     4A     5A

**Method of Compliance:** Energy Code     Performance     Prescriptive  
ASHRAE 90.1     Performance     Prescriptive  
(If "Other" specify source here) \_\_\_\_\_

**THERMAL ENVELOPE** (Prescriptive method only)

**Roof/ceiling Assembly** (each assembly)

Description of assembly: \_\_\_\_\_  
U-Value of total assembly: \_\_\_\_\_  
R-Value of insulation: \_\_\_\_\_  
Skylights in each assembly: \_\_\_\_\_  
    U-Value of skylight: \_\_\_\_\_  
total square footage of skylights in each assembly: \_\_\_\_\_

**Exterior Walls** (each assembly)

Description of assembly: \_\_\_\_\_  
U-Value of total assembly: \_\_\_\_\_  
R-Value of insulation: \_\_\_\_\_  
Openings (windows or doors with glazing)  
    U-Value of assembly: \_\_\_\_\_  
    Solar heat gain coefficient: \_\_\_\_\_  
    projection factor: \_\_\_\_\_  
    Door R-Values: \_\_\_\_\_

**Walls below grade** (each assembly)

Description of assembly: \_\_\_\_\_  
U-Value of total assembly: \_\_\_\_\_  
R-Value of insulation: \_\_\_\_\_

**Floors over unconditioned space** (each assembly)

Description of assembly: \_\_\_\_\_  
U-Value of total assembly: \_\_\_\_\_  
R-Value of insulation: \_\_\_\_\_

**Floors slab on grade**

Description of assembly: \_\_\_\_\_  
U-Value of total assembly: \_\_\_\_\_  
R-Value of insulation: \_\_\_\_\_  
Horizontal/vertical requirement: \_\_\_\_\_  
slab heated: \_\_\_\_\_

---

---

**2018 APPENDIX B**  
**BUILDING CODE SUMMARY FOR ALL COMMERCIAL PROJECTS**  
**STRUCTURAL DESIGN**  
**(PROVIDE ON THE STRUCTURAL SHEETS IF APPLICABLE)**

**DESIGN LOADS:**

**Importance Factors:** Snow (I<sub>s</sub>) \_\_\_\_\_  
Seismic (I<sub>E</sub>) \_\_\_\_\_ **EXISTING TO REMAIN**

**Live Loads:** Roof \_\_\_\_\_ psf  
Mezzanine \_\_\_\_\_ psf  
Floor \_\_\_\_\_ psf

**Ground Snow Load:** \_\_\_\_\_ psf

**Wind Load:** Ultimate Wind Speed \_\_\_\_\_ mph (ASCE-7)  
Exposure Category \_\_\_\_\_

**SEISMIC DESIGN CATEGORY:**  A  B  C  D

Provide the following Seismic Design Parameters:

**Risk Category** (Table 1604.5)  I  II  III  IV

**Spectral Response Acceleration** S<sub>s</sub> \_\_\_\_\_ %g S<sub>1</sub> \_\_\_\_\_ %g

**Site Classification** (ASCE 7)  A  B  C  D  E  F

Data Source:  Field Test  Presumptive  Historical Data

**Basic structural system**  Bearing Wall  Dual w/Special Moment Frame  
 Building Frame  Dual w/Intermediate R/C or Special Steel  
 Moment Frame  Inverted Pendulum

**Analysis Procedure:**  Simplified  Equivalent Lateral Force  Dynamic

**Architectural, Mechanical, Components anchored?**  Yes  No

**LATERAL DESIGN CONTROL:** Earthquake  Wind

**SOIL BEARING CAPACITIES:**

Field Test (provide copy of test report) \_\_\_\_\_ psf

Presumptive Bearing capacity \_\_\_\_\_ psf

Pile size, type, and capacity \_\_\_\_\_

---

---

---

---

**2018 APPENDIX B**  
**BUILDING CODE SUMMARY FOR ALL COMMERCIAL PROJECTS**  
**MECHANICAL DESIGN**  
**(PROVIDE ON THE MECHANICAL SHEETS IF APPLICABLE)**

**MECHANICAL SUMMARY**

**MECHANICAL SYSTEMS, SERVICE SYSTEMS AND EQUIPMENT**

**Thermal Zone**

winter dry bulb: \_\_\_\_\_  
summer dry bulb: \_\_\_\_\_

**Interior design conditions**

winter dry bulb: \_\_\_\_\_  
summer dry bulb: \_\_\_\_\_  
relative humidity: \_\_\_\_\_

**EXISTING TO REMAIN**

**Building heating load:** \_\_\_\_\_

**Building cooling load:** \_\_\_\_\_

**Mechanical Spacing Conditioning System**

Unitary

description of unit: \_\_\_\_\_  
heating efficiency: \_\_\_\_\_  
cooling efficiency: \_\_\_\_\_  
size category of unit: \_\_\_\_\_

Boiler

Size category. If oversized, state reason.: \_\_\_\_\_

Chiller

Size category. If oversized, state reason.: \_\_\_\_\_

**List equipment efficiencies:** \_\_\_\_\_

---

---

**2018 APPENDIX B**  
**BUILDING CODE SUMMARY FOR ALL COMMERCIAL PROJECTS**  
**ELECTRICAL DESIGN**  
**(PROVIDE ON THE ELECTRICAL SHEETS IF APPLICABLE)**

**ELECTRICAL SUMMARY**

**EXISTING TO REMAIN**

**ELECTRICAL SYSTEM AND EQUIPMENT**

**Method of Compliance:** Energy Code     Performance             Prescriptive  
ASHRAE 90.1     Performance             Prescriptive

**Lighting schedule** (each fixture type)

lamp type required in fixture  
number of lamps in fixture  
ballast type used in the fixture  
number of ballasts in fixture  
total wattage per fixture  
total interior wattage specified vs. allowed (whole building or space by space)  
total exterior wattage specified vs. allowed

**Additional Efficiency Package Options**

**(When using the 2018 NCECC; not required for ASHRAE 90.1)**

- C406.2 More Efficient HVAC Equipment Performance
  - C406.3 Reduced Lighting Power Density
  - C406.4 Enhanced Digital Lighting Controls
  - C406.5 On-Site Renewable Energy
  - C406.6 Dedicated Outdoor Air System
  - C406.7 Reduced Energy Use in Service Water Heating
- 
-

**ELECTRICAL NOTES**

1. THE CONTRACTOR SHALL BE FULLY COGNIZANT OF THE LATEST EDITION OF THE 2018 NORTH CAROLINA STATE BUILDING CODE, 2017 NEC, 2015 NFPA101, 2013 NFPA72, AND ALL LOCAL CODES, ORDINANCES OF THE AUTHORITIES HAVING JURISDICTION AND PERFORM ALL WORK IN ACCORDANCE WITH THE INTENT AND REQUIREMENTS OF THESE CODES, ORDINANCES AND AUTHORITIES.
2. DO NOT SCALE DRAWINGS. VERIFY DIMENSIONS IN FIELD PRIOR TO COMMENCEMENT OF ALL WORK. THE DRAWINGS ARE DIAGRAMMATIC AND INDICATE GENERAL LAYOUT OF ELECTRICAL SYSTEMS.
3. WHEREVER THE WORD "PROVIDE" IS USED, IT SHALL MEAN TO "FURNISH AND INSTALL".
4. FINAL CONNECTIONS TO EQUIPMENT SHALL BE PER MANUFACTURERS APPROVED WIRING DIAGRAMS, DETAILS AND INSTRUCTIONS. IT SHALL BE THE CONTRACTORS RESPONSIBILITY TO PROVIDE MATERIALS AND EQUIPMENT COMPATIBLE WITH EQUIPMENT ACTUALLY SUPPLIED.
5. PROVIDE WITH SHOP DRAWING SUBMITTAL, 1/4" SCALE LAYOUT DRAWINGS OF AREAS WITH ELECTRICAL SWITCHGEAR AND TRANSFORMERS. LAYOUT SHALL SHOW LOCATIONS OF AND SHALL BE COORDINATED WITH MECHANICAL EQUIPMENT AND MECHANICAL EQUIPMENT SHALL BE DRAIN TO SCALE.
6. IT IS THE INTENT OF THESE DRAWINGS AND SPECIFICATIONS TO ESTABLISH A STANDARD OF QUALITY. THE ENGINEER RESERVES THE RIGHT TO APPROVE METHODS AND MATERIALS NOT REFLECTED HEREIN.
7. THE CONTRACTOR SHALL REVIEW ARCHITECTURAL, STRUCTURAL AND MECHANICAL DRAWINGS AND SHALL PROVIDE LIGHTS, SWITCHES, RECEPTACLES, TELEPHONE OUTLETS, EQUIPMENT CONNECTIONS, ETC. AND ASSOCIATED CIRCUITING IN NEW AND REMODELED AREAS. EVEN IF SUCH AREAS ARE NOT SHOWN ON THE ELECTRICAL DRAWINGS, LAYOUTS, FIXTURE TYPES, QUANTITIES AND SPACING SHALL BE IN ACCORDANCE WITH SIMILAR AREAS ON THIS PROJECT. THE CONTRACTOR SHALL INCLUDE COSTS FOR THE ABOVE IN HIS BID. IN ADDITION, THE CONTRACTOR SHALL PROVIDE LAYOUT DRAWINGS FOR WORK IN SUCH AREAS AND SUBMIT FOR APPROVAL PRIOR TO ROUGH-IN.
8. THE CONTRACTOR SHALL REVIEW ARCHITECTURAL, STRUCTURAL, MECHANICAL AND OTHER DRAWINGS PRIOR TO BID AND SHALL COORDINATE ALL TRADES TO PROVIDE A COMPLETE PRODUCT TO AVOID CONFLICTS BETWEEN TRADES, AND TO DETERMINE WHICH TRADE IS TO PERFORM THE NECESSARY WORK. COORDINATION BETWEEN TRADES SHALL INCLUDE LOW VOLTAGE WIRING.
9. PROVIDE SUBSTITUTIONS OF ELECTRICAL EQUIPMENT OR REQUEST FOR "OR EQUIVALENT" OR "APPROVED EQUIVALENT" LISTING SHALL BE SUBMITTED TO THE ARCHITECT NOT LESS THAN TEN (10) WORKING DAYS PRIOR TO BID. REFER TO SPECIFICATIONS FOR ADDITIONAL INFORMATION.
10. WORK SHALL BE PERFORMED IN A WORKMANLIKE MANNER, CONSISTENT WITH THE HIGHEST LEVEL OF STANDARDS AND TO THE SATISFACTION OF THE ARCHITECT.
11. ALL EQUIPMENT AND MATERIALS PROVIDED SHALL BE NEW AND IN CONFORMANCE WITH APPLICABLE PROVISIONS OF NEMA, ANSI U.L., ETC. AND SHALL BEAR AN APPROVED TESTING AGENCY LABEL WHERE APPLICABLE.
12. PROVIDE PERMITS AND INSPECTIONS AS REQUIRED.
13. GUARANTEE THE INSTALLATION AGAINST DEFECTS IN MATERIALS AND WORKMANSHIP WHICH MAY OCCUR UNDER NORMAL USAGE FOR A PERIOD OF ONE YEAR AFTER OWNER'S ACCEPTANCE. DEFECTS SHALL BE PROMPTLY REMEDIATED WITHOUT COST TO THE OWNER.
14. VERIFY EXACT LOCATION OF EQUIPMENT TO BE FURNISHED BY OTHERS PRIOR TO ROUGH-IN. MODIFICATIONS REQUIRED DUE TO LACK OF COORDINATION BY CONTRACTORS, WILL BE DONE AT NO ADDITIONAL COST TO THE OWNER.
15. SYSTEMS SHALL BE TESTED FOR PROPER OPERATION. IF TESTS SHOW THAT WORK IS DEFECTIVE, THE CONTRACTOR SHALL MAKE CORRECTIONS NECESSARY AT NO COST TO THE OWNER.
16. THE CONTRACTOR SHALL PROVIDE OPERATING MANUALS TO THE OWNER.
17. THE CONTRACTOR SHALL BE RESPONSIBLE FOR INSTALLING ELECTRICAL UTILITY COMPANY FURNISHED CONDUIT FOR THE PRIMARY CONDUCTORS FROM THE PRIMARY POINT OF CONNECTION TO THE PAD MOUNT TRANSFORMER, PROVIDING A CONCRETE PAD PER ELECTRICAL UTILITY CO. REQUIREMENTS, AND TO COORDINATE WITH ALL REQUIREMENTS FOR CONDUIT ENTRY AND CABLE TERMINATIONS IN THE UTILITY TRANSFORMER. ANY CONFLICTS SHALL BE BROUGHT TO THE ATTENTION OF THE ARCHITECT/ ENGINEER PRIOR TO COMMENCEMENT OF WORK.
18. PROVIDE EXPANSION FITTINGS IN CONDUIT RUNS CROSSING STRUCTURAL EXPANSION JOINTS.
19. WIRE SHALL BE COPPER, 75 DEGREES C RATED FOR GENERAL USE. FOR HID FIXTURES AND WIRING WITHIN 3 INCHES OF FLUORESCENT BALLAST WIRE SHALL BE COPPER, MINIMUM 90 DEGREES C RATED. SIZES INDICATED ARE FOR INSTALLATION IN A MAXIMUM 30 DEGREES C AMBIENT. CONDUCTOR AMPACITY SHALL BE DERATED FOR HIGHER AMBIENT INSTALLATIONS. THE CONTRACTOR SHALL INCREASE THE SIZE OF THE CONDUCTOR TO MEET VOLTAGE DROP REQUIREMENTS WHERE FIELD CONDITIONS INCREASE THE CONDUIT RUN LENGTH SUCH THAT THE VOLTAGE DROP IS EFFECTED.
20. ALL EMPTY RACEWAY SYSTEMS SHALL HAVE A #12 PULL WIRE OR EQUIVALENT AND SHALL BE IDENTIFIED AT ALL JUNCTION, PULL AND TERMINATION POINTS, USING PERMANENT METALLIC TAGS. TAG SHALL INDICATE INTENDED USE OF CONDUIT, ORIGIN AND TERMINATION POINTS OF EACH INDIVIDUAL CONDUIT.
21. PRESENT SHOP DRAWING SUBMITTAL DATA AT ONE TIME. SUBMITTAL SHALL BE SUBMITTED IN PDF FORM WITH CONTRACTOR APPROVAL PRIOR TO SUBMITTAL. PARTIAL SUBMITTALS WILL NOT BE ACCEPTED. SUBMITTALS SHALL INCLUDE, BUT NOT BE LIMITED TO: LIGHTING FIXTURES, SWITCHGEAR, PANELBOARDS, WIRING DEVICES, SAFETY SWITCHES, FUSES, MOTOR STARTERS, LAMPS, CONDUIT, CONDUIT FITTINGS AND TRANSFORMERS.
22. CONTRACTOR SHALL BE RESPONSIBLE FOR REPLACING EQUIPMENT WHICH IS DAMAGED DUE TO INCORRECT FIELD WIRING PROVIDED UNDER THIS SECTION OR FACTORY WIRING IN EQUIPMENT PROVIDED UNDER THIS SECTION.
23. CONTRACTOR'S FAILURE TO ORDER OR RELEASE ORDER FOR MATERIALS AND/OR EQUIPMENT WILL NOT BE ACCEPTED AS A REASON TO SUBSTITUTE ALTERNATE MATERIAL, EQUIPMENT OR INSTALLATION METHODS.
24. SYSTEMS SHALL BE COMPLETE, OPERABLE AND READY FOR CONTINUOUS OPERATION. LIGHTS, SWITCHES, RECEPTACLES, MOTORS, ETC., SHALL BE CONNECTED AND OPERABLE.
25. RECEPTACLES WHICH ARE SHOWN WALL MOUNTED ON THE ELECTRICAL DRAWINGS ON WALLS WHICH, ON THE ARCHITECTURAL DRAWINGS AND ELEVATIONS ARE SHOWN AS GLASS OR PARTITIONS, SHALL BE FLUSH FLOOR DUPLEX RECEPTACLES MOUNTED ADJACENT TO BASE OR WALLS.
26. BOXES FOR TELEPHONE, T.V., COMPUTER, WIRING DEVICES, ETC., SHALL BE MINIMUM 4" SQUARE. THE CONTRACTOR SHALL COORDINATE WITH THE ARCHITECTURAL AND INTERIOR DRAWINGS FOR ALL ROUGH-IN LOCATIONS FOR APPLIANCES. IF NO LOCATION IS INDICATED, THE CONTRACTOR SHALL NOTIFY THE ARCHITECT IN WRITING FOR CLARIFICATION.
27. GROUNDING OF RECEPTACLES AND FIXED ELECTRICAL EQUIPMENT IN PATIENT CARE AREAS TO COMPLY WITH NEC 517.13 (A) & (B) AND NEC 517.31
28. ALL ELECTRICAL SYSTEMS COMPONENTS SHALL BE LISTED OR LABELED BY U.L. OR OTHER RECOGNIZED TESTING FACILITIES
29. THE LIGHTING HAS BEEN DESIGNED IN ACCORDANCE OF THE STATE OF NORTH CAROLINA STATE BUILDING CODE, ENERGY EFFICIENCY CODE, CHAPTER 13 (2018 EDITION).
30. VOLTAGE DROP CALCULATIONS ON ALL FEEDERS AND BRANCH CIRCUITS HAVE BEEN PERFORMED WITH A MAXIMUM OF 5 PERCENT VOLTAGE DROP TOTAL. THE CONTRACTOR IS RESPONSIBLE TO BE FAMILIAR WITH CHAPTER 13 AND SHALL UPSIZE THE CONDUCTORS FOR FEEDER AND BRANCH CIRCUITS BASED ON THE ACTUAL ROUTING IN THE FIELD.
31. THE CONTRACTOR SHALL HAVE A QUALIFIED PERSON COMMISSION ALL LIGHTING CONTROL SYSTEMS PRIOR TO OBTAINING THE C.O. THE PERSON SHALL TRAIN THE OWNER ON THE OPERATION OF THE LIGHTING CONTROLS.
32. ALL WIRING SHALL BE INSTALLED IN LISTED METALLIC RACEWAYS. RACEWAYS IN SLAB-ON-GRADE OR BELOW GRADE SHALL BE SCHEDULED 40 PVC. TRANSITIONS FROM BELOW TO ABOVE GRADE SHALL BE WITH RIGID STEEL ELBOWS WITH P.V.C. JACKET OR APPROVED EQUIVALENT PROTECTION. MET FITTINGS SHALL BE MALLEABLE IRON OR STEEL. CONDUCTORS SHALL BE INSULATED WITH A CODE SIZED COPPER GROUNDING CONDUCTOR. INCREASE CONDUIT SIZE AS REQUIRED.
33. FIRE ALARM, SOUND, TELEPHONE, COMPUTER, AND SIMILAR SYSTEMS CONDUITS LARGER THAN 1" SHALL HAVE LONG RADIUS SWEEPS (12 TIMES THE DIAMETER).
34. THE CONTRACTOR SHALL PROVIDE OFCI PROTECTION FOR PERSONNEL AS PER 2017 NEC 210.8(B).
35. FINAL CONNECTIONS TO MOTORS, TRANSFORMERS AND OTHER VIBRATING EQUIPMENT SHALL BE WITH SEAL TITE FLEX AND APPROVED FITTINGS. DO NOT SECURE CONDUITS, DISCONNECTS OR DEVICES TO DUCTWORK OR MECHANICAL EQUIPMENT.
36. WHERE PANELS ARE INSTALLED FLUSH WITH WALLS, EMPTY CONDUITS SHALL BE EXTENDED FROM THE PANEL TO AN ACCESSIBLE SPACE ABOVE OR BELOW. A MINIMUM OF ONE 3/4" SHALL BE INSTALLED FOR EVERY THREE SINGLE POLE SPARE CIRCUIT BREAKERS OR SPACES, OR FRACTION THEREOF, BUT NOT LESS THAN TWO CONDUITS. FLUSH MOUNTED PANEL SHALL BE INSTALLED IN 6" WALLS. COORDINATE WITH GENERAL CONTRACTOR.
37. WIRE TERMINATION PROVISIONS FOR PANELBOARDS, CIRCUIT BREAKERS, SAFETY SWITCHES, AND ALL OTHER ELECTRICAL APPARATUS SHALL BE LISTED AS SUITABLE FOR 75 DEGREE C.
38. ELECTRICAL CONTRACTOR SHALL PROVIDE CONTROLS, INTERLOCKS, ACCESSORIES, ETC., IN MOTOR CONTROL STARTERS AS REQUIRED BY THE TEMPERATURE CONTROL CONTRACTOR. STARTERS SHALL CONTAIN 120V CONTROL TRANSFORMER, PILOT LIGHT, AND PUSH BUTTONS OR SELECTOR SWITCH AS REQUIRED. IN ADDITION TO OTHER ITEMS (AUXILIARY CIRCUITS, DOOR SWITCHES, RELAYS, ETC.) REQUIRED. SUBMIT ELEMENTARY CONTROL DIAGRAMS FOR APPROVAL. SUBMITTALS SHALL INCLUDE INDICATION OF PRIOR REVIEW AND ACCEPTANCE BY TEMPERATURE CONTROL CONTRACTOR. REFER TO DIV. 15 DRAWINGS AND TEMPERATURE CONTROL DIAGRAMS FOR ADDITIONAL WIRE, RELAYS, TRANSFORMERS, CONNECTIONS, ETC. REQUIRED FOR A COMPLETE AND OPERABLE SYSTEM.
39. RECEPTACLE AND TELEPHONE OUTLETS AT COUNTER SHALL BE MOUNTED WITH THEIR LONG AXIS HORIZONTAL AT +42" UNLESS NOTED.
40. PANEL DIRECTORIES SHALL BE REMOVABLE. SUBMIT PROPOSED SCHEDULE OF DIRECTORIES TO OWNER FOR APPROVAL. ROOM NAMES AND NUMBERS SHALL BE AS DIRECTED BY OWNER. DIRECTORIES SHALL BE TYPED AND INSTALLED UNDER CLEAR PLASTIC COVERS.
41. DISCONNECT SWITCHES SHALL BE GENERAL DUTY TYPE. FUSIBLE SWITCHES SHALL ACCEPT CLASS "T" FUSES ONLY AND REJECT ALL OTHERS.
42. PROVIDE DYMO-TAPE TAG INSIDE COVER OF EACH FUSIBLE SWITCH, INDICATING SIZE AND TYPE OF FUSES PROVIDED.
43. DEVICES SHALL BE AS FOLLOWS: (OR OTHERWISE AS NOTED)  
A. RECEPTACLES - HUBBELL #5362 SERIES  
B. SWITCHES - HUBBELL #1221 SERIES  
C. DIMMERS - LUTRON "NOVA" SERIES  
D. THE COLOR OF THE DEVICES AND COVER PLATES SHALL BE AS DIRECTED BY ARCHITECT. IN DAMP OR WET LOCATIONS COVER PLATES SHALL BE STAINLESS STEEL. IN DRY LOCATIONS COVER PLATES SHALL BE SMOOTH HIGH ABUSE NYLON OR EQUIVALENT. PROVIDE COVER PLATES FOR SWITCHES, RECEPTACLES, TELEPHONE, TELEVISION, COMPUTER, AND J-BOX OUTLETS AS REQUIRED.
44. THE CONTRACTOR SHALL COORDINATE WITH THE TELEPHONE UTILITY FOR PROVIDING THE REQUIRED CONDUIT SIZE AND NUMBER TO THE TENANT SPACE. THE CONTRACTOR SHALL PROVIDE ALL CONDUITS WITH PULL CORDS AND SHALL INSTALL FROM THE LOCAL TELEPHONE BOARD TO THE MAIN POINT OF SERVICE
45. FIRE ALARM SYSTEM. CONTRACTOR SHALL PROVIDE DEVICES, CONDUIT, WIRES AND CABLE AS DIRECTED BY EQUIPMENT AND WORKMANSHIP SHALL MEET PREVAILING CODES. THE SYSTEM SHALL BE COMPLETE AND OPERABLE IN EVERY RESPECT. SUBMIT SINGLE LINE OF SYSTEM WITH SHOP DRAWINGS. THIS SINGLE LINE DIAGRAM SHALL SHOW DEVICES, CONDUIT, WIRE AND CABLE SIZES. EQUIPMENT TO BE USED AND SHALL BE STAMPED AND SIGNED BY LOCAL FIRE DEPARTMENT. SYSTEM CALIBRATION AND TESTING SHALL BE BY FACTORY CERTIFIED TECHNICIAN.
46. SEE DIVISION 22 & 23 DRAWINGS FOR LOCATION OF MECHANICAL EQUIPMENT. PROVIDE SERVICE TO AND CONNECT EQUIPMENT AS REQUIRED.
47. SPLICES IN EXTERIOR PULL BOXES AND MANHOLES SHALL BE MADE WATER PROOF USING "SCOTCHCAST" SPLICE KIT OR APPROVED EQUIVALENT. SEAL ENDS OF CONDUITS AND DUCTS WITH "DUCT SEAL" OR APPROVED EQUIVALENT
48. CIRCUIT BREAKERS SHALL BE BOLT-ON TYPE AND FUSES SHALL BE BUSSMANN OR LITTLEFUSE.
49. PROVIDE APPROVED FIRE STOPPING MATERIALS AT ALL PENETRATIONS THROUGH FIRE RATED FLOORS AND WALLS TO PREVENT THE PASSAGE OF SMOKE, FIRE TOXIC GAS OR WATER THROUGH THE PENETRATION EITHER BEFORE, DURING OR AFTER A FIRE, AS REQUIRED BY ARTICLE 300, OF THE NEC.
50. PROVIDE TWO (2) SETS OF THREE (3) SPARE FUSES FOR EACH SIZE AND TYPE PROVIDED ON THIS PROJECT. INSTALL FUSES IN A HINGED DOOR, SHEET METAL STORAGE CABINET EQUIPPED WITH CLIPS OR CUBICLES, EACH MARKED WITH THE SIZE AND TYPE FUSE STORED THEREIN. PROVIDE NAMEPLATE "SPARE FUSES". INSTALL IN LOCATIONS AS DIRECTED BY OWNER.
51. PULL BOXES, CABINETS, ETC. MOUNTED ON THE EXTERIOR AT GRADE LEVEL, SHALL BE WEATHER PROOF TYPE WITH HINGED LOCKABLE COVERS SECURED WITH TAMPER-PROOF SCREWS.
52. FLUSH FLOOR RECEPTACLE OUTLETS SHALL BE HUBBELL #8-2529 WITH BRASS COVER #8-3725. PROVIDE CARPET OR TILE FLANGE TO MATCH FLOOR FINISH.
53. FLUSH FLOOR TELEPHONE OUTLETS SHALL BE HUBBELL #8-2529 WITH BRASS COVER #8-2725. PROVIDE CARPET OR TILE FLANGE TO MATCH FLOOR FINISH.
54. RECESSED LIGHT FIXTURES INSTALLED IN GYP. BOARD OR PLASTER CEILINGS SHALL HAVE PLASTER FRAMES INSTALLED PRIOR TO CEILING MATERIAL.
55. RECESSED FIXTURES INSTALLED INDOORS SHALL BE THERMALLY PROTECTED.
56. FIXTURES RECESSED IN "T-BAR" U.L. FIRE RATED CEILING ASSEMBLIES SHALL BE SUPPORTED INDEPENDENTLY OF THE CEILING SYSTEM, WITH TWO #12 HANGER WIRES UP TO STRUCTURE. SECURE HANGER WIRES TO CORNERS OF FIXTURE. CLIP FIXTURE TO GRID ON TWO SIDES WITH FACTORY-FURNISHED CLIPS. FINAL CONNECTION TO FIXTURE SHALL BE MADE WITH FLEXIBLE U.L. APPROVED ASSEMBLY.
57. CONDUITS PENETRATING THRU ROOF SHALL HAVE FLASHING WITH CAULK TYPE COUNTER FLASHING SLEEVE. INSTALLATION SHALL BE WATER TIGHT.
58. PROVIDE A GREEN GROUND CONDUCTOR AND METAL RACEWAY IN ALL BRANCH CIRCUITS FEEDING OUTLETS IN MEDICAL EXAM ROOMS & PATIENT CARE ROOMS AS PER 2017 NEC 517.13. PROVIDE EMT METAL RACEWAY OR HEALTH CARE RATED MC CABLE AS PER 2017 NEC 517.13.
59. AN ISOLATED GROUND RECEPTACLE SHALL NOT BE INSTALLED WITHIN A PATIENT CARE WING AS PER 2017 NEC 517.16
60. AUTOMATIC LIGHTING CONTROL DEVICES SHALL COMPLY WITH NFPA 101: 7.8.1.2.2 (1) THROUGH (7).
61. THE CONTRACTOR SHALL LABEL ALL ELECTRICAL CONTROL DEVICES (OCCUPANCY/VACANCY SENSORS) WITH THE CORRECT CIRCUIT, ACCORDING TO CIRCUIT PANEL DESIGN FOR MAINTENANCE AS REQUIRED BY NEC 408.4.
62. ADDITIONAL NOTES FOR NEW PANELBOARDS:  
A. PROVIDE LIGHTING AND RECEPTACLE PANELS AS INDICATED ON THE PLANS AND AS SPECIFIED HEREIN. ALL PANELS SHALL BE DEAD FRONT, CIRCUIT BREAKER TYPE, AND SHALL BEAR THE U.L. LABEL AS WELL AS MEET ALL APPLICABLE NEMA REQUIREMENTS.  
B. UNLESS OTHERWISE NOTED, TOP OF PANELS SHALL BE MOUNTED 6"-0" A.F.F.  
C. ALL PANELS SHALL HAVE TYPEWRITTEN CIRCUIT DIRECTORIES MOUNTED INSIDE OF DOOR.  
D. PANELS SHALL BE SUITABLE FOR THE SERVICE RATING AND THE A.I.C. RATING INDICATED ON THE PANEL SCHEDULES.  
E. ALL BREAKERS SHALL BE FULL SPACE, INDIVIDUAL FRAME TYPE, BOLT-ON E. TYPE. NO "PIGGY-BACK" OR TANDEM BREAKERS WILL BE PERMITTED.  
F. CONTRACTOR SHALL PROVIDE ON ALL FLUSH (RECESSED) MOUNTED PANELS TWO (2), SPARE 2" CONDUITS STUBBED INTO THE CEILING SPACE.  
G. ALL CURRENT CARRYING BUS BARS SHALL BE COPPER.

**ELECTRICAL SYMBOL LIST**

S	WALL SWITCH - 1 POLE - 125V - 20 AMP, MOUNT 46" A.F.F. 42" A.F.F. @ COUNTERTOPS OR AS NOTED, QUIET TYPE.	W.P.	WEATHERPROOF
S <sub>3</sub>	WALL SWITCH - 3 WAY - 125V - 20 AMP, MOUNT 46" A.F.F. OR AS NOTED	I.G.	ISOLATED GROUND
S <sub>D</sub>	DIMMER SWITCH - 125V - 1000W - 20 AMP, MOUNT 46" A.F.F. OR AS NOTED	N.L.	NIGHT LIGHT
S <sub>M</sub>	MOTOR RATED "SNAP" SWITCH - 125V - 20 AMP, MOUNT AS NOTED	EM.	EMERGENCY
	LINE VOLTAGE OCCUPANCY SENSOR SWITCH - 120V-800W-6.7 AMP, MOUNT 46" A.F.F. OR AS NOTED. DUAL TECHNOLOGY	E OR EX	EXISTING
	LINE VOLTAGE OCCUPANCY SENSOR SWITCH - 125V-800W-6 AMP, CEILING MOUNT OR AS NOTED. DUAL TECHNOLOGY	N.	NEW
	LINE VOLTAGE OCCUPANCY SENSOR SWITCH - 125V-800W-6 AMP, CEILING MOUNT FOR CORRIDOR OR AS NOTED. DUAL TECHNOLOGY		EMERGENCY POWER OFF (EPO) BUTTON
	HOSPITAL GRADE DUPLEX RECEPTACLE - 125V - 20 AMP - NEMA 5-20R, MOUNT 15" A.F.F. (STANDARD), 42" A.F.F. @ COUNTERTOPS OR AS NOTED		X-RAY "IN USE" LIGHT
	HOSPITAL GRADE QUAD RECEPTACLE - 125V - 20 AMP - NEMA 5-20R, MOUNT 15" A.F.F. (STANDARD), 42" A.F.F. @ COUNTERTOPS OR AS NOTED		X-RAY "IN USE" LIGHTING CONTROL PANEL
GFI	DUPLEX RECEPTACLE ON GROUND FAULT INTERRUPTER CIRCUIT. 125V - 20 AMP - NEMA 5-20R		DOOR SAFETY SWITCH
	JUNCTION BOX MOUNTED ABOVE CEILING.		RECESSED LED DOWNLIGHT, SEE LUMINAIRE LIST.
	JUNCTION BOX RECESS OR MOUNTED IN WALL.		2' x 4' LED LAY-IN TROFFER, SEE LUMINAIRE LIST.
	TELEVISION OUTLET MOUNT 15" A.F.F. OR AS NOTED, PROVIDE CONDUIT IN WALL STUBBED UP 6" INTO CEILING CAVITY. COORDINATE EXACT SIZE OF J-BOX AND CONDUIT WITH CABLING CONTRACTOR.		EMERGENCY BATTERY PACK WITH LAMPS, SEE LUMINAIRE LIST.
	ETHERNET OUTLET, MOUNT 15" A.F.F. OR AS NOTED. PROVIDE CONDUIT IN WALL STUBBED UP 6" INTO CEILING CAVITY. COORDINATE EXACT SIZE OF J-BOX AND CONDUIT WITH CABLING CONTRACTOR.		EXISTING 2' x 4' LAY-IN TROFFER.
	EXHAUST FAN - FRACTIONAL HORSEPOWER.		ELECTRICAL CONDUIT CONCEALED IN WALLS OR IN CONCRETE
	MOTOR - NUMBER DENOTES HORSEPOWER.		ELECTRICAL CONDUIT UNDERGROUND
	PANELBOARD		ELECTRICAL CONTROL WIRING
	NON-FUSED DISCONNECT SWITCH.		ELECTRICAL WIRE HOME-RUN, 1ST HASH MARK REPRESENTS THE HOT, SECOND HASH MARK WITH A DOT REPRESENTS THE NEUTRAL, ARC WIRE MARK REPRESENTS THE GROUND.
	FUSED DISCONNECT SWITCH OR CIRCUIT BREAKER ENCLOSURE.		ELECTRICAL MULTI-WIRE HOME-RUN, HASH MARKS WITHOUT DOT REPRESENTS THE NUMBER OF HOT'S, HASH MARK WITH A DOT REPRESENTS THE NEUTRAL, ARC WIRE MARK REPRESENTS THE GROUND, NUMBER OF ARROWS INDICATE NUMBER OF CIRCUITS
	PUSH BUTTON		ELECTRICAL WIRE HOME-RUN, HASH MARKS WITHOUT DOT REPRESENTS THE NUMBER OF HOT'S, ARC WIRE MARK REPRESENTS THE GROUND

**LIGHTING FIXTURE SCHEDULE**

TYPE	NOTE	MANUF	PART #	WATTAGE	LUMENS	VOLTAGE
A	6" ROUND LED DOWNLIGHT	LITHONIA	LDN6 35/25 LOGAR LD MVOLT E210 TRV	27	2500	120/277
E	LED EMERGENCY LIGHT W/90 MIN EM BATTERY	LITHONIA	ELM2L	5		120/277

**NOTE**

THESE DRAWINGS ARE PREPARED PER ESTABLISHED INDUSTRY STANDARDS AND REPRESENT THE ENGINEERS DESIGN CONCEPT. THEY ARE NOT INTENDED TO PROVIDE EVERY DETAIL OR CONDITION REQUIRED TO CONSTRUCT THE BUILDING. THE CONTRACTOR THROUGH SUBMITTALS AND OTHER COORDINATION EFFORTS IS FULLY RESPONSIBLE FOR PROVIDING A COMPLETE AND OPERATIONAL BUILDING WHETHER INDICATED ON THE PLANS OR NOT.

ANDREW J YOUNGROSS, P.E.  
2522 S.E. COLUSA AVE.  
PORT ST. LUCIE, FLORIDA

HYAC  
PLUMBING  
ELECTRICAL

TEL: 561-900-2447  
FAX: 561-274-0222  
E-MAIL: andrew@ecfla.com

**ELECTRICAL DRAWING LIST**

DRAWING NUMBER	DRAWING NAME
E01	ELECTRICAL NOTES, LEGEND AND SCHEDULES
E11	FIRST FLOOR ELECTRICAL PLAN
E21	FIRST FLOOR LIGHTING PLAN
E31	SIEMENS REFERENCE DESIGN PLANS
E32	SIEMENS REFERENCE DESIGN PLANS

FINAL SUBMITTAL for construction

An Interior Renovation for:  
**Harnett Health**  
**RAD Room 1318 Renovation**  
215 Brightwater Drive  
Lillington, North Carolina

job no. 23-016/23077  
principal: AJY/AA  
designer: RR  
file name:  
date: 08.10.23  
title: ELECTRICAL NOTES, LEGEND, AND SCHEDULES

5 | E

**C.D. HAIR ARCHITECT**  
8661 Lake Worth Road  
Lake Worth, FL  
AR96135

revision:

NORTH CAROLINA  
PROFESSIONAL  
SEAL  
048609  
ENGINEER  
ANDREW J. YOUNGROSS

DRAWINGS FROM SIEMENS INCLUDED ON SHEETS E3.1 AND E3.2 ARE INCLUDED IN THE SCOPE OF WORK. CONTRACTOR SHALL PROVIDE ALL CONDUIT AND WIRING AS NECESSARY.

**C.D. HAIR ARCHITECT**  
 8661 Lake Worth Road  
 Lake Worth, FL  
 AR96135

revision:

NORTH CAROLINA  
 PROFESSIONAL  
 SEAL  
 048609  
 ENGINEER  
 ANDREW J. YOUNGROSS

An Interior Renovation for:  
**Harnett Health  
 RAD Room 1318 Renovation**  
 215 Brightwater Drive  
 Lillington, North Carolina

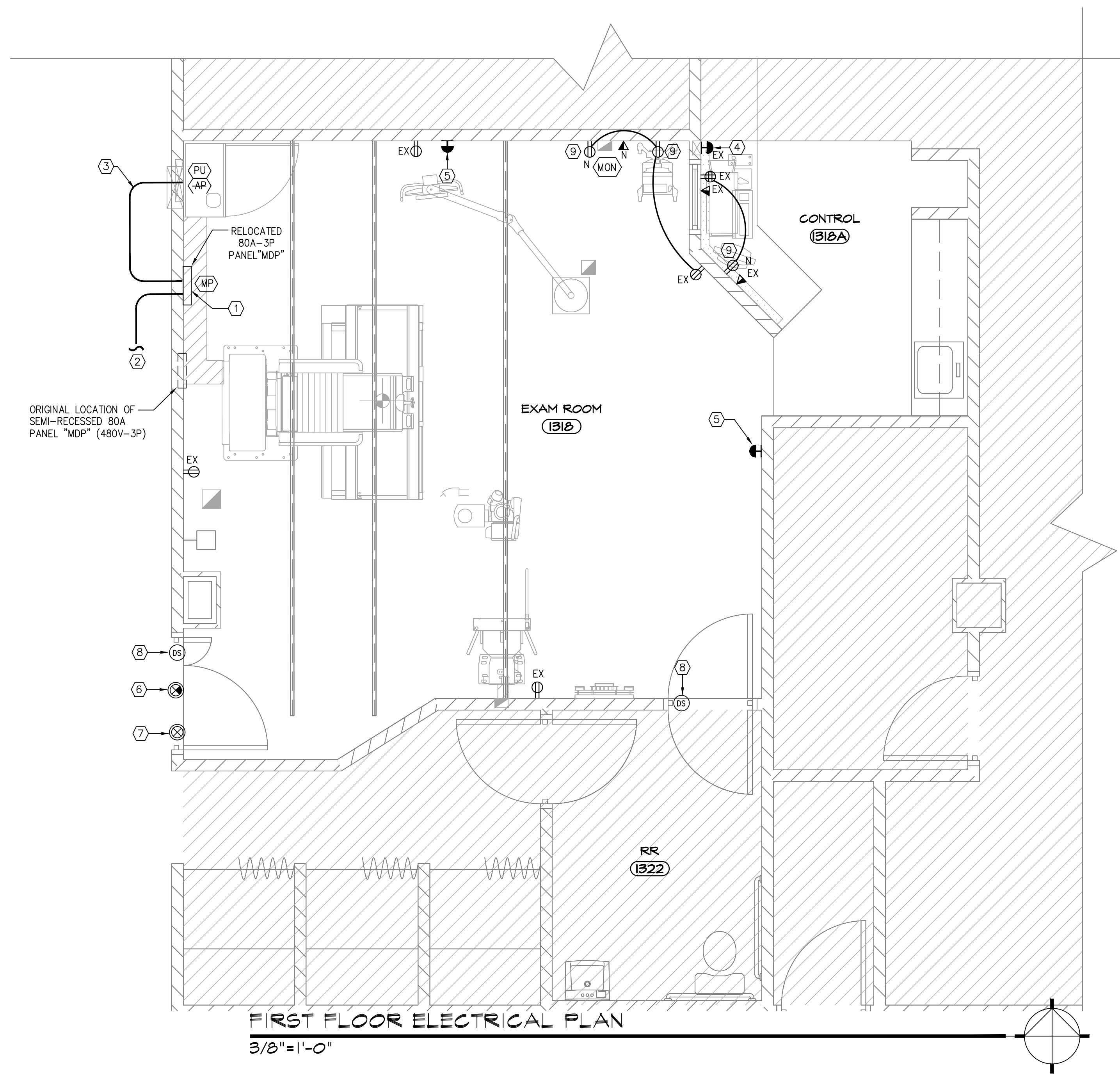

job no. 23-016/23077  
 principal: AJY/AA  
 designer: RR  
 file name:  
 date: 08.10.23  
 title: **FIRST FLOOR  
 ELECTRICAL  
 PLAN**

**5 E**

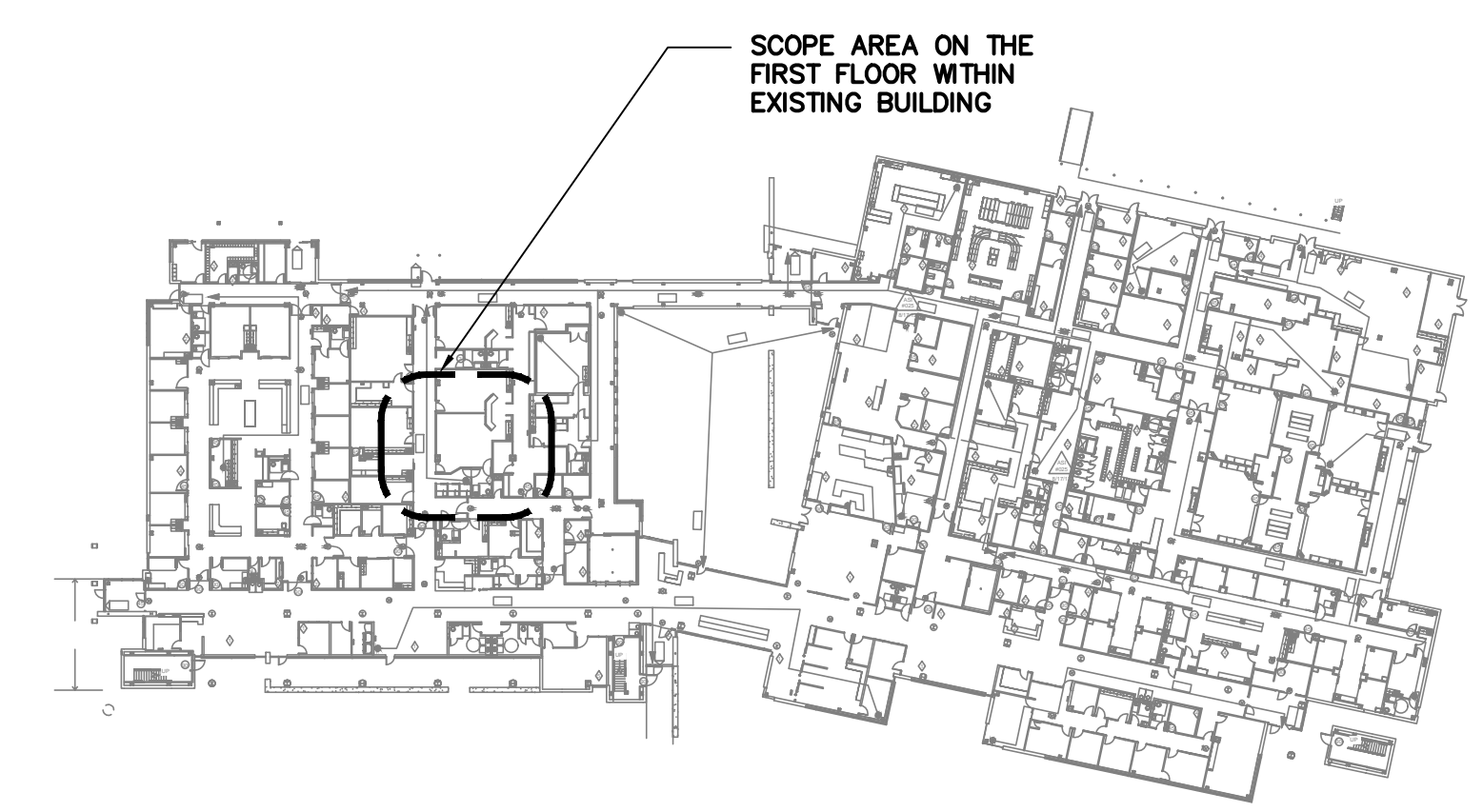

- NOTES**
- SEE SIEMENS ELECTRICAL DRAWINGS ON SHEETS E3.1, AND E3.2 FOR WORK SCOPE REQUIRED.
  - PROVIDE LABOR AND MATERIALS TO INSTALL NEW OVERHEAD AND IN FLOOR RACEWAY TO ACCOMMODATE NEW RAD EQUIPMENT TOO ADAPT TO EXISTING RACEWAY.
  - PROVIDE POST TESTING OF ROOM FOR GROUND IMPEDANCE.

- PLAN KEY NOTES**
- RELOCATED SEMI-RECESSED MAIN DISTRIBUTION PANEL "MDP". PANEL "MDP" HAS 100A CIRCUIT BREAKER (WITH 80A PLUG) AND 150A LOW PEAK FUSES IN SERIES (480V-3P). SEE SHEETS E3.1 (SIEMENS), E3.2 (SIEMENS) AND E4.1 (ELECTRICAL RISER) FOR ADDITIONAL INFORMATION. NOTE: PANEL "MDP" REQUIRES 48" DEEP X 30" WIDE CLEARANCE IN FRONT OF THE PANEL. VERIFY WITH SIEMENS REPRESENTATIVE IF THE LOCATION SHOWN IS ACCEPTABLE PRIOR TO COMMENCEMENT OF WORK - AN ALTERNATE LOCATION MAY BE REQUIRED.
  - PROVIDE 20" X 20" SPLICE BOX ABOVE THE CEILING IN THE AREA OF ORIGINAL PANEL "MDP". INTERCEPT THE EXISTING CONDUIT/ CONDUCTORS FEEDING PANEL "MDP" & EXTEND TO RELOCATED PANEL "MDP" (3#2 CU & 1#2 CU GRD IN 1-1/4" CONDUIT) USE POLARIS TAPS. NOTE: SIEMENS DESIGN DRAWINGS REQUIRE THE GROUND CONDUCTOR TO BE THE SAME SIZE AS THE PHASE CONDUCTORS. FIELD VERIFY ALL CONDUCTORS ARE #2 CU - IF THE GROUND IS NOT #2 CU A NEW GROUND CONDUCTOR WILL NEED TO BE INSTALLED.
  - FURNISH AND INSTALL NEW 3#2 CU & 1#2 CU GRD CONDUCTORS IN 1-1/4" CONDUIT FROM RELOCATED 80A PANEL "MDP" TO SIEMENS GENERATOR CABINET.
  - EXISTING EMERGENCY POWER OFF (EPO) SWITCH TO REMAIN.
  - FURNISH AND INSTALL NEW EMERGENCY POWER OFF (EPO) SWITCH - TIE INTO EXISTING EPO SWITCH. SEE SIEMENS DESIGN DRAWINGS ON SHEETS E3.1, E3.2 FOR ADDITIONAL INFORMATION. PROVIDE CONDUIT/CONDUCTORS AS NECESSARY.
  - EXISTING X-RAY ROOM "IN USE" LIGHT TO REMAIN.
  - REWORK EXISTING X-RAY LIGHT CONTROL PANEL AND CONNECT TO EXISTING X-RAY ROOM "IN-USE" LIGHT AND NEW SIEMENS SYSTEM. SEE SIEMENS DESIGN DRAWINGS ON SHEETS E3.1, E3.2 FOR ADDITIONAL INFORMATION. PROVIDE CONDUIT/CONDUCTORS & RELAYS AS NECESSARY.
  - FURNISH AND INSTALL DOOR INTERLOCK SWITCH, IF NOT EXISTING AT PRESENT. SEE SIEMENS DESIGN DRAWINGS ON SHEETS E3.1, E3.2 FOR ADDITIONAL INFORMATION. PROVIDE CONDUIT/ CONDUCTORS AS NECESSARY AND TIE INTO SIEMENS SYSTEM.
  - FURNISH AND INSTALL 20A,120V, HOSPITAL GRADE DUPLEX WITH RED FACEPLATE. PROVIDE CONDUIT/CONDUCTORS AND CONNECT TO RECEPTACLE SHOWN.



**NOTE**

THESE DRAWINGS ARE PREPARED PER ESTABLISHED INDUSTRY STANDARDS AND REPRESENT THE ENGINEERS DESIGN CONCEPT. THEY ARE NOT INTENDED TO PROVIDE EVERY DETAIL OR CONDITION REQUIRED TO CONSTRUCT THE BUILDING. THE CONTRACTOR THROUGH SUBMITTALS AND OTHER COORDINATION EFFORTS IS FULLY RESPONSIBLE FOR PROVIDING A COMPLETE AND OPERATIONAL BUILDING WHETHER INDICATED ON THE PLANS OR NOT.

ANDREW J. YOUNGROSS, P.E.  
 2522 S.E. COLUSA AVE.  
 PORT ST. LUCIE, FLORIDA  
 TEL: 561-900-2447  
 FAX: 561-274-0222  
 E-MAIL: andrew@tecfia.com

HVAC  
 PLUMBING  
 ELECTRICAL

**FINAL SUBMITTAL for construction**

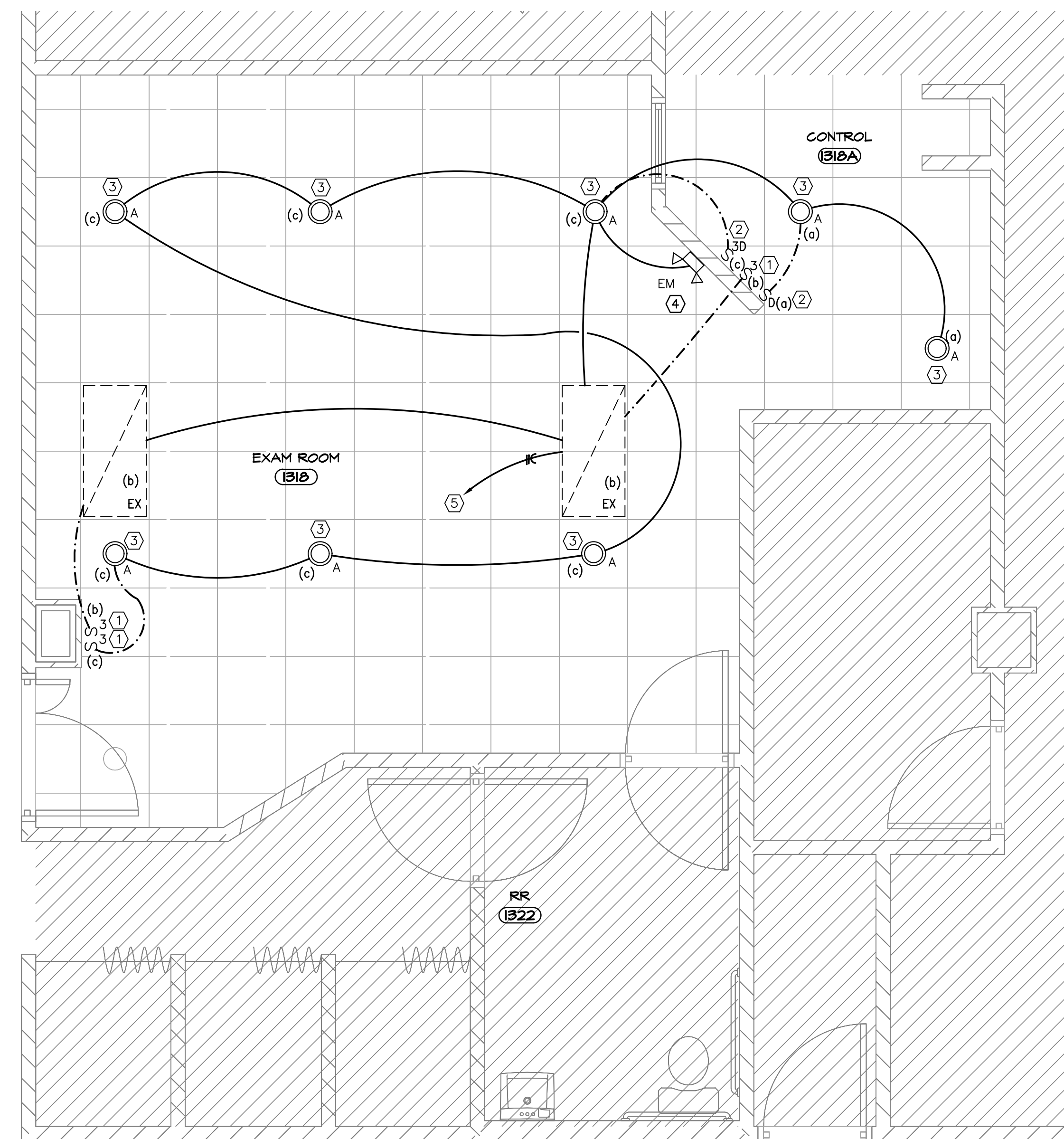

FIRST FLOOR LIGHTING PLAN  
3/8"=1'-0"

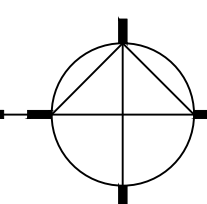

PLAN KEY NOTES	
①	FURNISH AND INSTALL NEW LIGHT SWITCH (ON/OFF). 1-WAY OR 3-WAY AS NOTED.
②	FURNISH AND INSTALL NEW 0-10V LED DIMMABLE LIGHT SWITCH. 1-WAY OR 3-WAY AS NOTED.
③	PROVIDE NEW LED DOWN LIGHT. CONNECT TO SWITCHES AS SHOWN. PROVIDE CONDUIT/ CONDUCTORS AS NECESSARY.
④	PROVIDE NEW EMERGENCY LIGHT. CONNECT TO THE EXISTING LIGHTING CIRCUIT SERVING THIS ROOM - CONNECT ON THE SUPPLY SIDE OF ANY LOCAL SWITCH CONTROLS. PROVIDE CONDUIT/ CONDUCTORS AS REQUIRED.
⑤	CONNECT LIGHTS IN THE EXAM ROOM TO THE EXISTING LIGHTING CIRCUIT SERVING THIS ROOM. PROVIDE CONDUIT/ CONDUCTORS AS NECESSARY.

GENERAL NOTES	
REMOVE ANY UNUSED LIGHT SWITCHES.	
LIGHTING LEGEND	
	A - LIGHT TYPE "A" (b) - LIGHT SWITCHING ZONE "(b)"
	S_D - DIMMER SWITCH (c) - LIGHT SWITCHING ZONE "(c)"

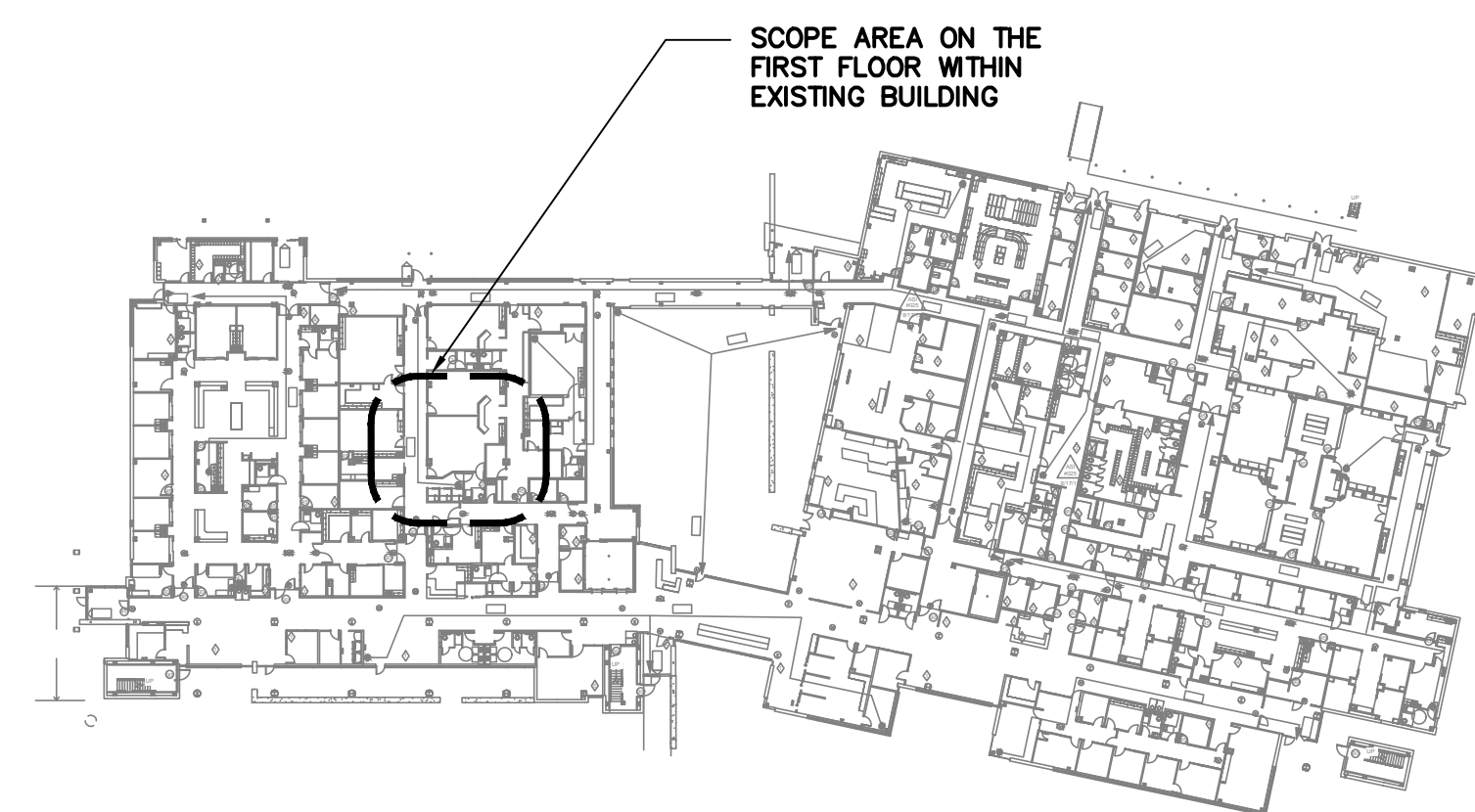

OVERALL FIRST FLOOR PLAN  
NTS

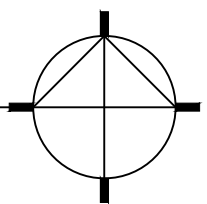

**NOTE**  
THESE DRAWINGS ARE PREPARED PER ESTABLISHED INDUSTRY STANDARDS AND REPRESENT THE ENGINEERS DESIGN CONCEPT. THEY ARE NOT INTENDED TO PROVIDE EVERY DETAIL OR CONDITION REQUIRED TO CONSTRUCT THE BUILDING. THE CONTRACTOR THROUGH SUBMITTALS AND OTHER COORDINATION EFFORTS IS FULLY RESPONSIBLE FOR PROVIDING A COMPLETE AND OPERATIONAL BUILDING WHETHER INDICATED ON THE PLANS OR NOT.

ANDREW J. YOUNGROSS, P.E.  
2522 S.E. COLUSA AVE.  
PORT ST. LUCIE, FLORIDA  
TEL: 561-900-2447  
FAX: 561-274-0222  
E-MAIL: andrew@tecfia.com

HVAC  
PLUMBING  
ELECTRICAL

12.1  
5 E

C.D. HAIR ARCHITECT  
8661 Lake Worth Road  
Lake Worth, FL  
AR96135

revision:

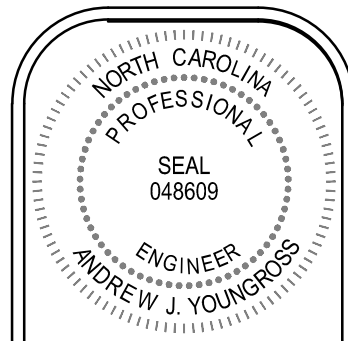
An Interior Renovation for:  
**Harnett Health  
RAD Room 1318 Renovation**  
215 Brightwater Drive  
Lillington, North Carolina

job no. 23-016/23077  
principal: AJY/AA  
designer: RR  
file name:  
date: 08.10.23  
title: FIRST FLOOR LIGHTING PLAN

FINAL SUBMITTAL for construction





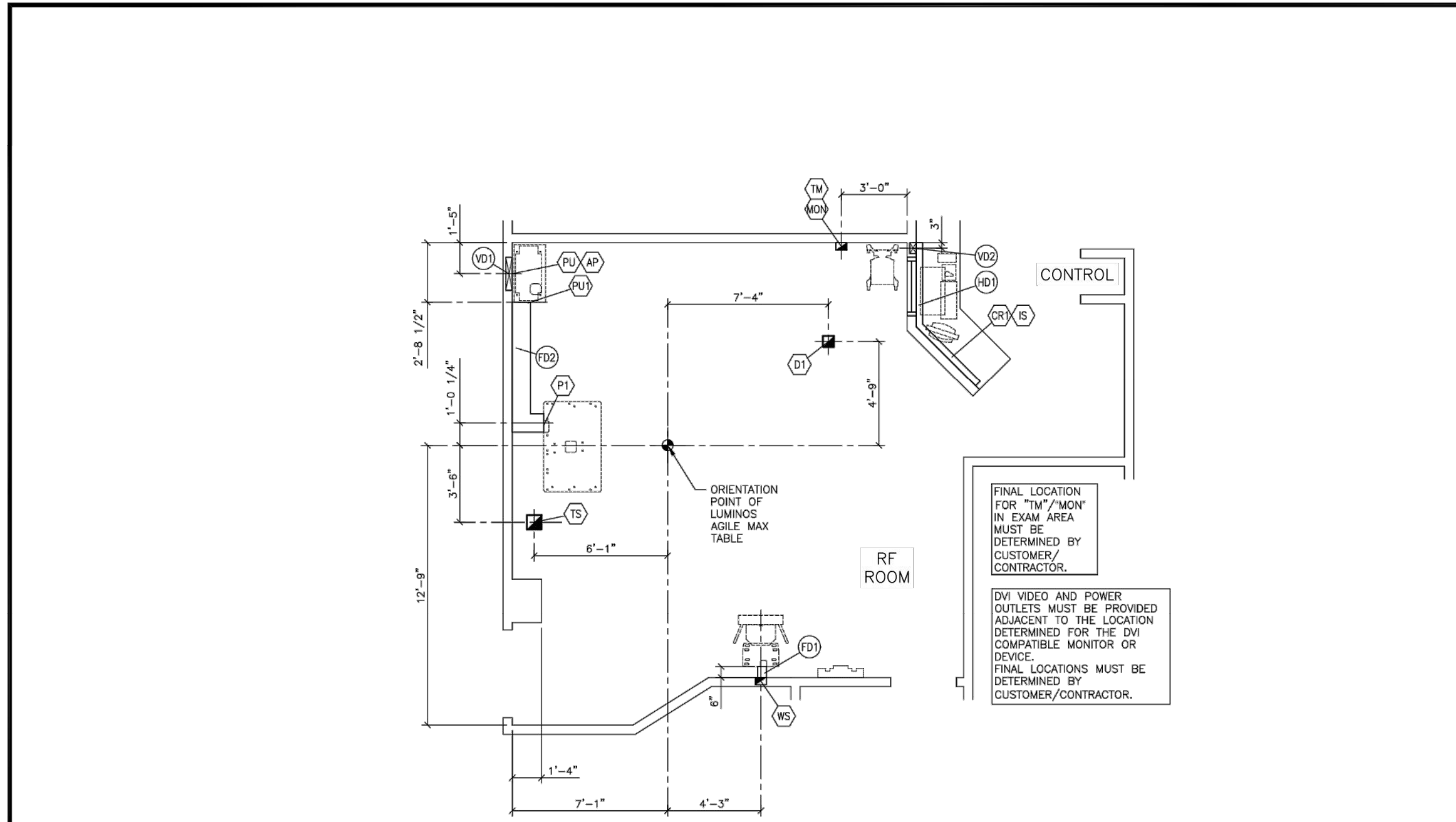

ELECTRICAL DIMENSION PLAN

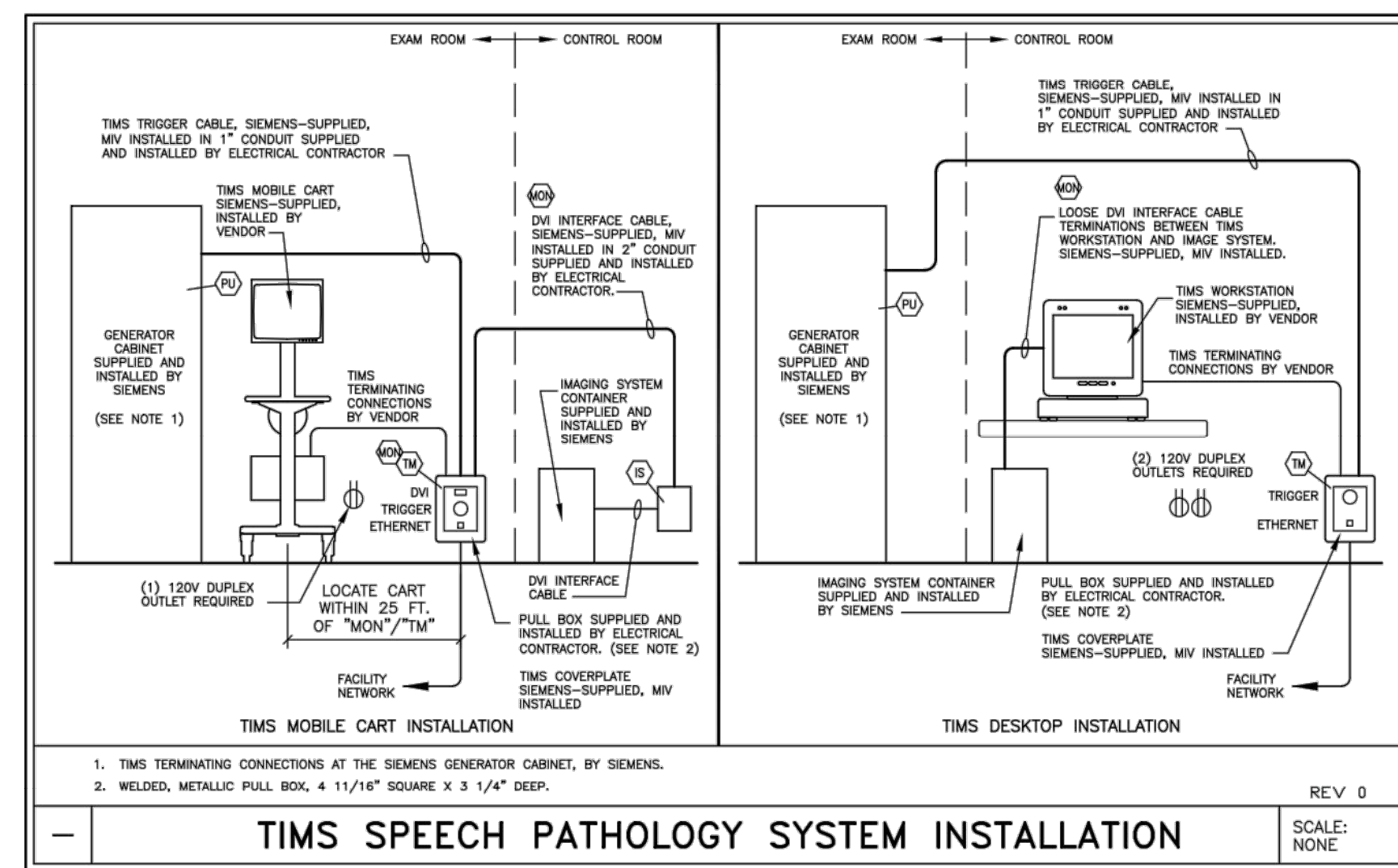

**ATTENTION:**

THIS DRAWING IS DESIGNED TO CONFORM TO FEATURES AND EQUIPMENT REQUIREMENTS PRESENTED AT THE TIME OF THEIR PREPARATION. SINCE BOTH THESE FACTORS ARE SUBJECT TO DESIGN MODIFICATION, THEY ARE NOT TO BE USED FOR CONSTRUCTION PURPOSES.  
THIS SET OF PLANS REPRESENTS A COMPLETE SET OF DETAILS AND SHOULD NOT BE SEPARATED.

IT IS RECOMMENDED THAT THE SIEMENS DRAWINGS BE INCORPORATED WITH THE CONSTRUCTION DOCUMENTS FOR REFERENCE.

MINIMUM CEILING HEIGHT W/RESTRICTION	CEILING HEIGHT WITHOUT RESTRICTION	RECOMMENDED CEILING HEIGHT
SEE RM HT REQMTS	SEE RM HT REQMTS	9'-6"

ALL DIMENSIONS SHOWN ON THIS DRAWING ARE FROM FINISHED SURFACES.  
THIS DRAWING DOES NOT PROVIDE RADIATION SHIELDING REQUIREMENTS FOR X-RAY AND ASSOCIATED EQUIPMENT. THE CUSTOMER IS RESPONSIBLE FOR CONSULTING WITH A REGISTERED RADIATION PHYSICIST TO SPECIFY RADIATION PROTECTION.

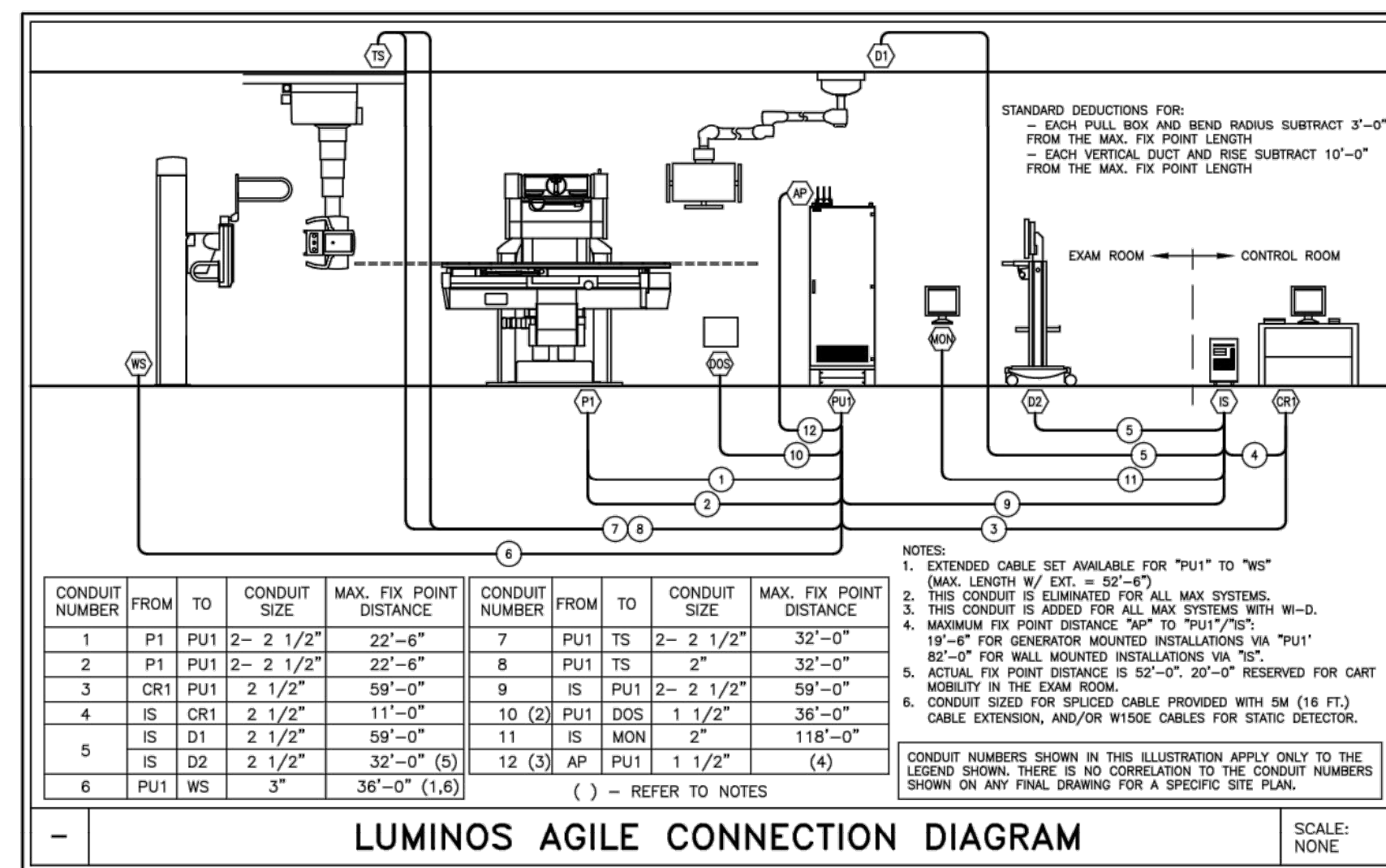

**GROUNDING NOTES**

- EQUIPMENT GROUNDING CONDUCTOR TO COMPLY WITH THE FOLLOWING:
- 1) SIZE GROUNDING WIRE TO SIEMENS EQUIPMENT PER POWER SCHEDULE REQUIREMENTS.
  - 2) DERIVED FROM THE ELECTRICAL SERVICE, TRANSFORMER OR MAIN DISTRIBUTION PANEL FEEDING THE SIEMENS EQUIPMENT.
  - 3) RUN IN THE SAME CONDUIT, TROUGH OR RACEWAY AS THE PHASE CONDUCTORS.
  - 4) CONTINUOUS, WITH NO BREAKS OR USE OF CONDUIT, CHASSIS OR EARTH AS THE SOLE GROUNDING PATH.
  - 5) BONDED TO CHASSIS AND/OR CONDUIT IN ACCORDANCE WITH THE NEC REQUIREMENTS.
  - 6) MINIMIZE CONNECTIONS OR TERMINALS TO ENSURE CONTINUITY OVER THE LIFE OF THE INSTALLATION.
  - 7) AS A NORM, THERE SHOULD NOT BE ANY CURRENT PRESENCE ON THE GROUND CONDUCTOR, BUT IT IS ACCEPTABLE TO HAVE  $\leq 500\text{mA}$  DURING OPERATION OF THE IMAGING EQUIPMENT.

**POWER QUALITY**

POOR POWER WILL ALTER EQUIPMENT PERFORMANCE  
IT IS IN THE CUSTOMER'S INTEREST THAT THE ELECTRICAL CONTRACTOR BE RESPONSIBLE FOR TESTING AND VERIFYING THAT THE EQUIPMENT POWER SUPPLY COMPLIES WITH THE SIEMENS SPECIFICATIONS.

**POLYDOROS F80 80kW**

X-RAY GENERATOR POWER REQUIREMENTS

INCOMING POWER:	480 VOLTS, 3 PHASE, 60HZ
CIRCUIT BREAKER:	80 AMPS
GENERATOR OUTPUT:	80 KW
ALLOWABLE IMPEDANCE:	$\leq 0.16 \Omega$
MAXIMUM MOMENTARY LOAD:	126 KVA
LINE VOLTAGE VARIATION:	$\pm 10\%$ MAX.
PHASE IMBALANCE:	$\pm 2\%$
FREQUENCY VARIATION:	$\pm 1$ Hz

NOTE:  
ALL INCOMING POWER SUPPLIES, FOR THE SIEMENS EQUIPMENT, ARE TO BE DEDICATED (BACK TO SOURCE) ISOLATED AND INSULATED FROM ANY OTHER EQUIPMENT, SUCH AS, ELEVATORS, GENERATORS, HVAC SYSTEMS, ETC.

A NEUTRAL CONDUCTOR, IF PRESENT, IS NOT USED FOR THE LINE VOLTAGE CONNECTION TO THE SIEMENS EQUIPMENT. IF THE NEUTRAL CONDUCTOR IS PROVIDED, IT SHOULD NOT BE ELECTRICALLY CONNECTED AT ANY POINT IN THE POWER DISTRIBUTION TO THE SIEMENS EQUIPMENT UNLESS SPECIFICALLY REQUIRED. UNINTENTIONAL NEUTRAL TO GROUND BONDS MAY VIOLATE LOCAL AND NATIONAL ELECTRICAL CODES, AS WELL AS CREATE GROUNDING PROBLEMS.  
IF AN ON-SITE TRANSFORMER IS REQUIRED TO OBTAIN XP MODALITY OPERATING VOLTAGE, IT MUST BE OF SUFFICIENT CAPACITY AND CHARACTERISTICS TO MAINTAIN SUPPLY VOLTAGE AND IMPEDANCE REQUIREMENTS (TRANSFORMER & CONDUCTORS).

ATTENTION:  
SIEMENS MEDICAL SYSTEMS, INC. RECOMMENDS THAT THE INCOMING POWER LINES BE ANALYZED WITH RESPECT TO TRANSIENT SURGES AND IMPULSES, SAGS, AND OVERVOLTAGES.

**POWER SCHEDULE**

ALL CONDUITS AND WIRES SIZES MUST BE DETERMINED BY THE ELECTRICAL ENGINEER OF RECORD PER N.E.C. AND TO MAINTAIN SIEMENS IMPEDANCE REQUIREMENTS.

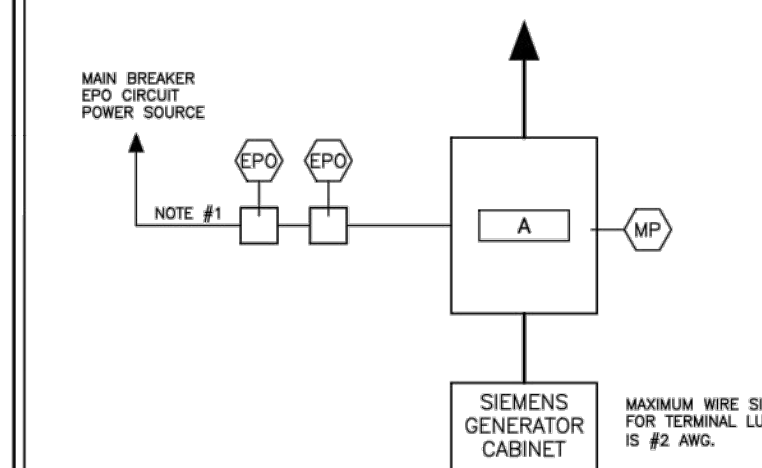

ITEM	QTY	DESCRIPTION
MP	1	MAIN PANEL WITH CIRCUIT BREAKER FLUSH OR SURFACE MOUNTED.
A	1	BREAKER MUST HAVE TRIPPING DEVICE SO WHEN ANY EPO IS PRESSED THE BREAKER TRIPS.

BREAKER AMPS: SEE POWER REQUIREMENTS

VOLTS	PHASES	NEUTRAL	GROUND	TOTAL WIRES
480Y	3	0	1	4 (NOTE 1)

1) ALL WIRES MUST BE SAME SIZE.  
NOTE: UNLESS OTHERWISE NOTED, ALL BREAKERS WILL BE 80% RATED

NOTE 1 - EPO CIRCUIT #1  
MAIN CIRCUIT BREAKER EMERGENCY POWER OFF BUTTON WITH PROTECTIVE COVER THAT PREVENTS ACCIDENTAL ACTIVATION. THE EPO MUST BE OF FAIL-SAFE DESIGN. ALL EPO'S TO HAVE MECHANICAL LATCHING MECHANISM. EPO MUST BE RESET BEFORE MAIN BREAKER CAN RESUME OPERATION. CONTACTS AND WIRING CONFIGURATION TO BE DESIGNED BY ELECTRICAL ENGINEER OF RECORD.

THE EPO'S MUST BE INSTALLED BY A QUALIFIED ELECTRICAL CONTRACTOR ACCORDING TO NATIONAL ELECTRICAL CODE, STATE AND LOCAL REGULATIONS. MEASURES SHOULD BE TAKEN TO DESIGN THE CIRCUIT IN SUCH A WAY THAT IT WILL ALWAYS WORK WHEN THE MEDICAL EQUIPMENT IS POWERED. THE CUSTOMER IS SOLELY RESPONSIBLE FOR THE IMPLEMENTATION OF THE EPO'S AND THEIR ASSOCIATED CIRCUITS AND MUST MAKE THE FINAL DETERMINATION CONSIDERING ALL SITE CONDITIONS AND REGULATORY FACTORS.

ALL ITEMS LISTED IN THIS SCHEDULE SHALL BE SUPPLIED AND INSTALLED BY CUSTOMER/CONTRACTOR.

PROJECT MANAGER: JASON BOSWELL  
TEL: (919) 368-5780  
FAX: (919) 368-5780  
EMAIL: JASON.BOSWELL@SIEMENS-HEALTHINEERS.COM

**SIEMENS**

**CENTRAL HARNETT HEALTH HOSPITAL**  
215 BRIGHTWATER DRIVE, LILLINGTON, NC 27546  
RF ROOM - LUMINOS AGILE MAX

PROJECT #: **2311952** SHEET: **E-102**

DATE: 06/22/23

SCALE: AS NOTED REF. #: 30277332

**NOTE**

THESE DRAWINGS ARE PREPARED PER ESTABLISHED INDUSTRY STANDARDS AND REPRESENT THE ENGINEERS DESIGN CONCEPT. THEY ARE NOT INTENDED TO PROVIDE EVERY DETAIL OR CONDITION REQUIRED TO CONSTRUCT THE BUILDING. THE CONTRACTOR THROUGH SUBMITTALS AND OTHER COORDINATION EFFORTS IS FULLY RESPONSIBLE FOR PROVIDING A COMPLETE AND OPERATIONAL BUILDING WHETHER INDICATED ON THE PLANS OR NOT.

ANDREW J YOUNGROSS, P.E.  
2522 S.E. COLUSA AVE.  
PORT ST. LUCIE, FLORIDA

TEL: 561-900-2447  
FAX: 561-274-0222  
E-MAIL: andrew@ecfla.com

REFERENCE DOCUMENT - NOT FOR CONSTRUCTION

**C.D. HAIR ARCHITECT**  
8661 Lake Worth Road  
Lake Worth, FL  
AR96135

SEAL  
048609  
ENGINEER  
ANDREW J. YOUNGROSS

An Interior Renovation for:  
**Harnett Health  
RAD Room 1318 Renovation**  
215 Brightwater Drive  
Lillington, North Carolina

job no. 23-016/23077  
principal: AJY/AA  
designer: RR  
file name:  
date: 08.10.23  
title: SIEMENS REFERENCE DESIGN PLANS

**13.2**

5 E

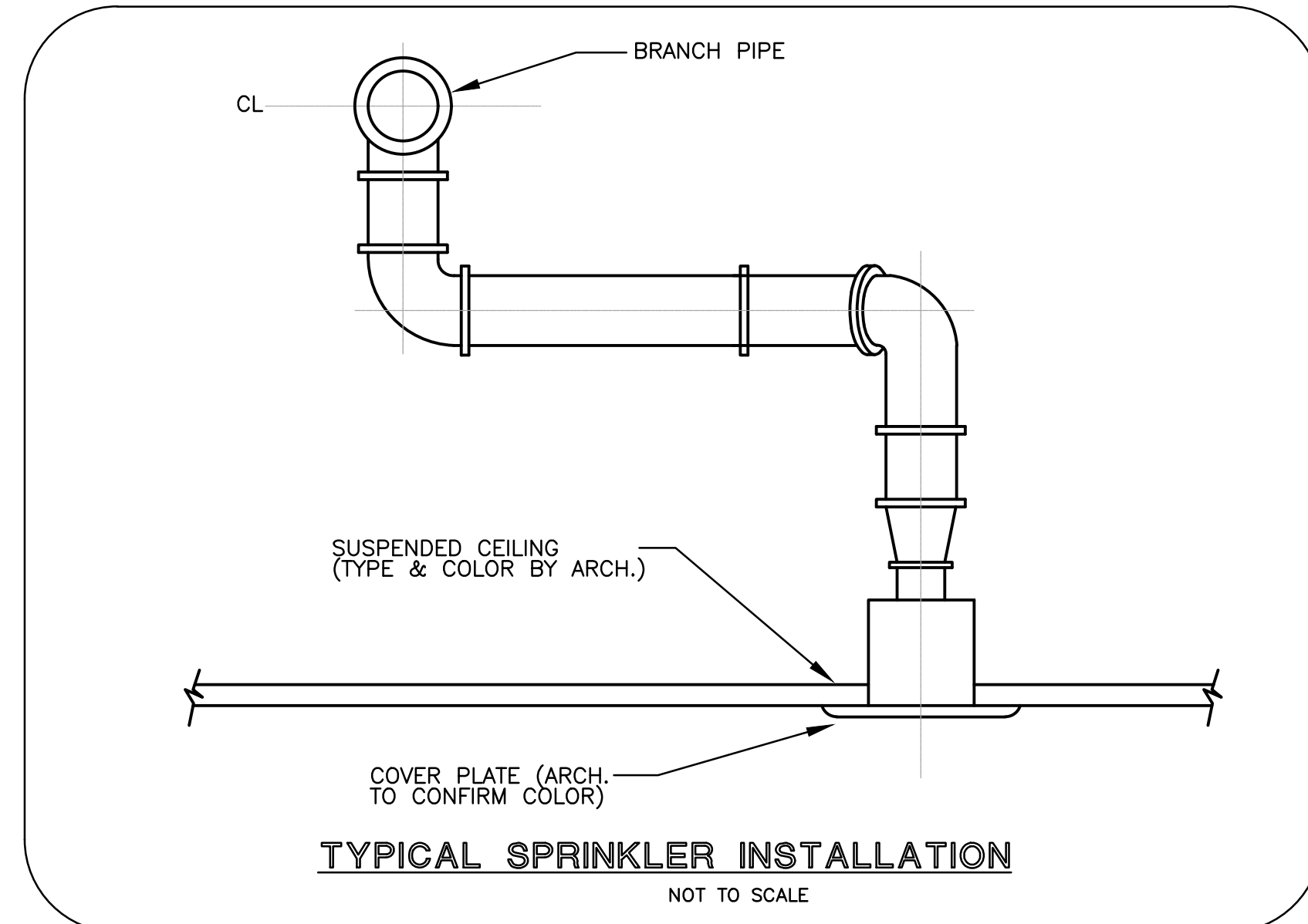
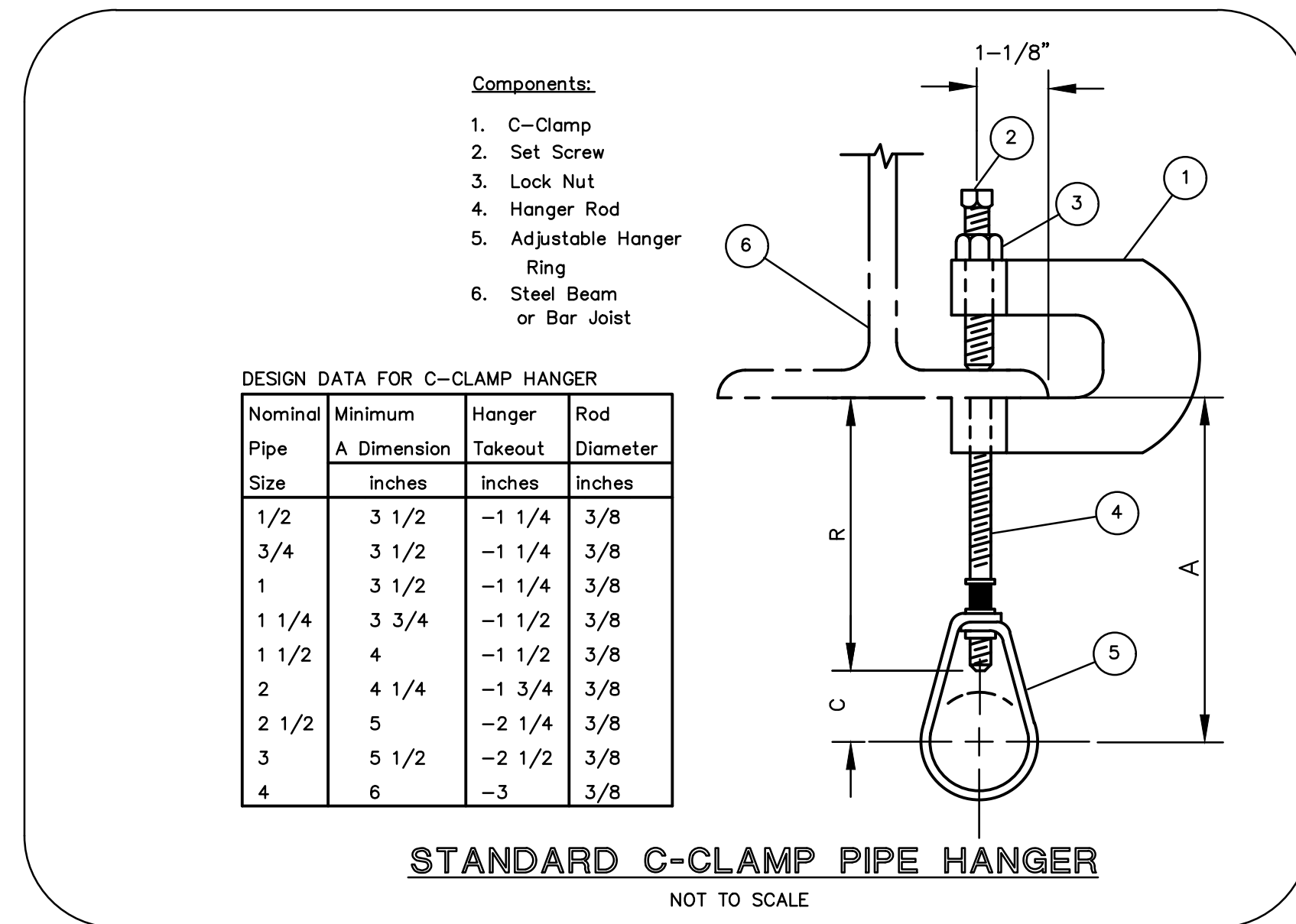

**NOTE**

THESE DRAWINGS ARE INTENDED TO PROVIDE THE GENERAL REQUIREMENTS AND DESIGN CRITERIA FOR THE PROJECT. FIRE SPRINKLER CONTRACTOR SHALL BE FULLY RESPONSIBLE FOR OBTAINING CURRENT FIRE FLOWS FROM LOCAL AUTHORITIES AND PREPARE COMPLETE DESIGN AND INSTALLATION DRAWINGS AND CALCULATIONS AS NECESSARY FOR FULL COMPLIANCE WITH ALL LAWS AND REGULATIONS AS REQUIRED BY THE AUTHORITY HAVING JURISDICTION. NO ADDITIONAL COMPENSATION WILL BE PROVIDED FOR ANYTHING DEEMED TO BE REQUIRED BY THE AUTHORITY HAVING JURISDICTION AFTER AWARD OF BID.

- FIRE PROTECTION NOTES**
- SUBMISSION OF PROPOSAL DIRECTLY OR INDIRECTLY IN CONNECTION WITH THIS WORK SHALL IMPLY THAT THE BIDDER HAS EXAMINED THE JOB SITE UNDER WHICH HE WILL BE OBLIGATED TO OPERATE SHOULD HE BE AWARDED THE WORK UNDER THIS CONTRACT. NO EXTRA CHARGE WILL BE ALLOWED FOR FAILURE OF ANY BIDDER TO EXAMINE THE SITE PRIOR TO BID.
  - CONTRACTOR SHALL VISIT THE SITE AND VERIFY ALL DIMENSIONS IN THE FIELD, AND SHALL ADVISE THE ARCHITECT/ENGINEER AND THE OWNER OF ANY DISCREPANCIES BEFORE PERFORMING THE WORK.
  - ALL WORK SHALL CONFORM TO ALL STATE AND LOCAL CODES, RULES AND REGULATIONS AND ORDINANCES INCLUDING BUT NOT LIMITED TO NORTH CAROLINA STATE FIRE PREVENTION CODE 2018, NFPA 1 (2018), NFPA 101 (2018), NFPA 13 (2016), NFPA 20 (2016), NFPA 24 (2016), NFPA 25 (2017).
  - CONTRACTOR SHALL SECURE AND PAY ALL FEES AND PERMITS PERTAINING TO THE CONTRACT.
  - ALL EQUIPMENT SHALL BE INSTALLED IN STRICT COMPLIANCE WITH THE MANUFACTURER'S WRITTEN INSTRUCTIONS. THE CONTRACTOR SHALL PROVIDE ALL HANGERS AND SUPPORTS REQUIRED FOR A COMPLETE INSTALLATION.
  - RESTORATION OF EXISTING SYSTEMS, DEVICES, FINISHES, ETC. DAMAGED OR ALTERED BY NEW WORK TO ACCEPTABLE CONDITION AS DETERMINED BY THE OWNER, ARCHITECT AND/OR ENGINEER.
  - CONTRACTOR SHALL BE RESPONSIBLE FOR WORKMEN'S IDENTIFICATION AND BADGING, SAFETY AND FIRE PROTECTION, CONTRACTOR'S LIABILITY INSURANCE, BARRICADES, WARNING SIGNS, TRASH REMOVAL, CUTTING AND PATCHING.
  - CONTRACTOR SHALL SCHEDULE ALL SHUTDOWNS THAT AFFECT UTILITIES AND PORTIONS OF THE BUILDING THAT MUST REMAIN IN OPERATION WITH THE OWNER.
  - CONTRACTOR SHALL COORDINATE ALL WORK WITH THE OWNER AND ALL OTHER CONTRACTORS.
  - CONTRACTOR SHALL BE RESPONSIBLE FOR ALL RIGGING, HANDLING AND PROTECTION OF MATERIALS.
  - CONTRACTOR SHALL PROVIDE LABOR TO RECEIVE, UNLOAD, STORE, PROTECT AND TRANSFER TO POINT OF INSTALLATION, OWNER FURNISHED ITEMS.
  - WHERE CONDUIT, CABLES, DUCTWORK OR PIPING PASSES THROUGH FIRE RATED FLOORS OR WALLS, THE SLEEVES SHALL BE COMPLETELY SEALED WITH A FIRE STOP MATERIAL THAT IS UL LISTED AND ACCEPTED BY THE BUILDING DEPARTMENT AND FIRE DEPARTMENT AS BEING SUITABLE FOR THIS SERVICE. SUCH AS DOW CORNING CORP., SILICONE ELASTOMER, DOW CORNING 3-6548 SILICONE RTV FOAM, OR APPROVED EQUAL. THIS MATERIAL SHALL BE INSTALLED IN ACCORDANCE WITH THE REQUIREMENTS OF THE MANUFACTURER TO MAINTAIN THE FIRE RATING OF THE PENETRATED WALL OR FLOOR.
  - CONTRACTOR SHALL BE RESPONSIBLE FOR ALL CORING AS IT RELATES TO HIS WORK.
  - CONTRACTOR SHALL BE RESPONSIBLE FOR ALL BEAM PENETRATIONS AS IT RELATES TO HIS WORK. CONTRACTOR SHALL SUBMIT SIZE AND LOCATION TO THE STRUCTURAL ENGINEER FOR REVIEW AND DETAIL.
  - CONTRACTOR TO PROVIDE HYDRAULIC CALCULATIONS, SYSTEM LINE SIZING, PUMP SIZING, AND SHOP DRAWINGS TO ENGINEER OF RECORD FOR APPROVAL PRIOR TO COMMENCEMENT OF WORK.
  - CONTRACTOR SHALL SUBMIT (1) SET OF INSTALLATION SHOP DRAWINGS AND EQUIPMENT CUT SHEETS IN ELECTRONIC FORMAT TO THE ENGINEER FOR APPROVAL PRIOR TO STARTING ANY WORK.
  - UPON COMPLETION OF CONSTRUCTION CONTRACTOR SHALL SUPPLY THE ENGINEER WITH (1) COMPLETE SET OF MYLAR AS-BUILT DOCUMENTS AND (3) COMPLETE COPIES OF OPERATIONS AND MAINTENANCE MANUALS. MYLARS SHALL BE OBTAINED AT CONTRACTOR'S EXPENSE.
  - ALL EXPOSED FIRE SPRINKLER PIPING TO BE PAINTED RED.
  - ALL FIRE SPRINKLERS TO BE INSTALLED CENTERED IN TILE.
  - ACCEPTANCE AND HYDROSTATIC TESTS SHALL BE PERFORMED IN ACCORDANCE WITH CHAPTER 25 OF NFPA 13.
  - DO NOT SCALE DRAWINGS FOR EXACT DIMENSIONS. VERIFY ALL CONDITIONS AT THE JOB SITE AND COORDINATE WITH ALL TRADES PRIOR TO COMMENCEMENT. THE SPRINKLER DRAWINGS ARE INTENDED TO BE DIAGRAMMATIC.
  - MATERIALS, EQUIPMENT AND INSTALLATION SHALL BE GUARANTEED FOR A PERIOD OF ONE (1) YEAR FROM THE DATE OF ACCEPTANCE. DEFECTS WHICH APPEAR DURING THAT PERIOD SHALL BE CORRECTED AT THE SPRINKLER CONTRACTOR'S EXPENSE.

- GENERAL NOTES - OFFICES**
- FIRE SPRINKLER SPACING TO BE:  
LIGHT HAZARD: OFFICE AREA  
DENSITY: 0.1GPM/SF @ 15'X15' MAX
  - ALL FIRE SPRINKLER DEVICES TO BE UL AND/OR FM APPROVED.
  - SPRINKLER PIPING SHALL BE STEEL PIPE (ASTM 53, 120, OR 135) WITH 150 PSI MALLEABLE IRON FITTINGS WITH THREADED CONNECTIONS OR TYPE "L" HARD DRAWN COPPER TUBING WITH COPPER OR BRASS FITTINGS AND 125 PSI SOLDER JOINTS ("NO-LEAD SOLDER").  
A. SCH. 40, ALLIED XL OR AMERICAN BLT FOR 1" THRU 2"  
B. SCH. 10 FOR 2-1/2" AND LARGER  
C. SCH. 80 IF 1/2" OR 3/4" NIPPLE IS USED.  
NOTE: NIPPLE CANNOT EXCEED 4" IN LENGTH AND SUPPLY ONLY ONE HEAD PER NFPA 13.
  - FITTINGS  
A. BLACK CIS CLASS 125 FOR 1" THRU 2".  
B. GROOVED TYPE FOR 2-1/2" AND LARGER.
  - HANGERS TO BE IN ACCORDANCE WITH NFPA 13 AND LOCAL AUTHORITIES. SPRINKLER PIPING IS NOT TO BE SUPPORTED FROM ANY MECHANICAL OR ELECTRICAL DEVICES.  
MAXIMUM DISTANCE BETWEEN PIPE SUPPORTS:  
• 12'-0" FOR 1 1/4" DIAMETER PIPE AND SMALLER  
• 15'-0" FOR 1 1/2" DIAMETER PIPE AND LARGER

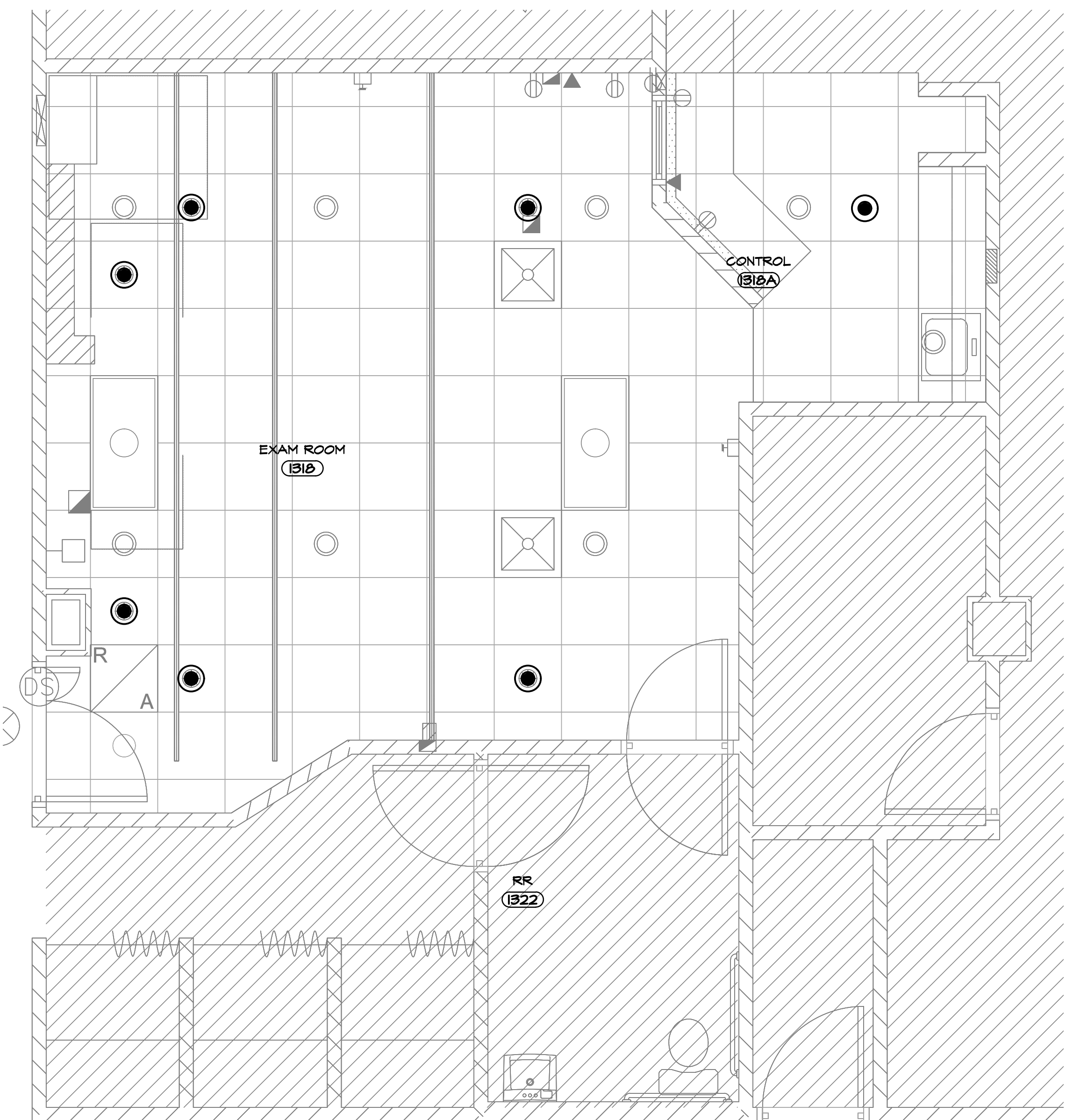

**SCOPE OF WORK**

REMOVE AND REPLACE SEMI-RECESSED PENDANT SPRINKLER HEAD WITH CONCEALED PENDANT HEAD TO ACCOMMODATE NEW CEILING GRID LAYOUT.

SPRINKLER TYPE	SYMBOL	TEMPERATURE RATING (°F.)	NOMINAL ORIFICE SIZE	MANUFACTURER & MODEL	MAXIMUM SPACING	FLOW/PRESS GPM / PSI
CONCEALED QR-PEN	☉	165	1/2" K=5.6	RELIABLE G5-56 LIGHT HAZARD, COMMERCIAL AREAS	15'X15'	5.6 / 7.0

NOTE: THE FIRE PROTECTION CONTRACTOR SHALL CONFIRM SPACING, LOCATION AND COVERAGE FOR ALL FIRE SPRINKLERS. COORDINATE WITH ALL TRADES.

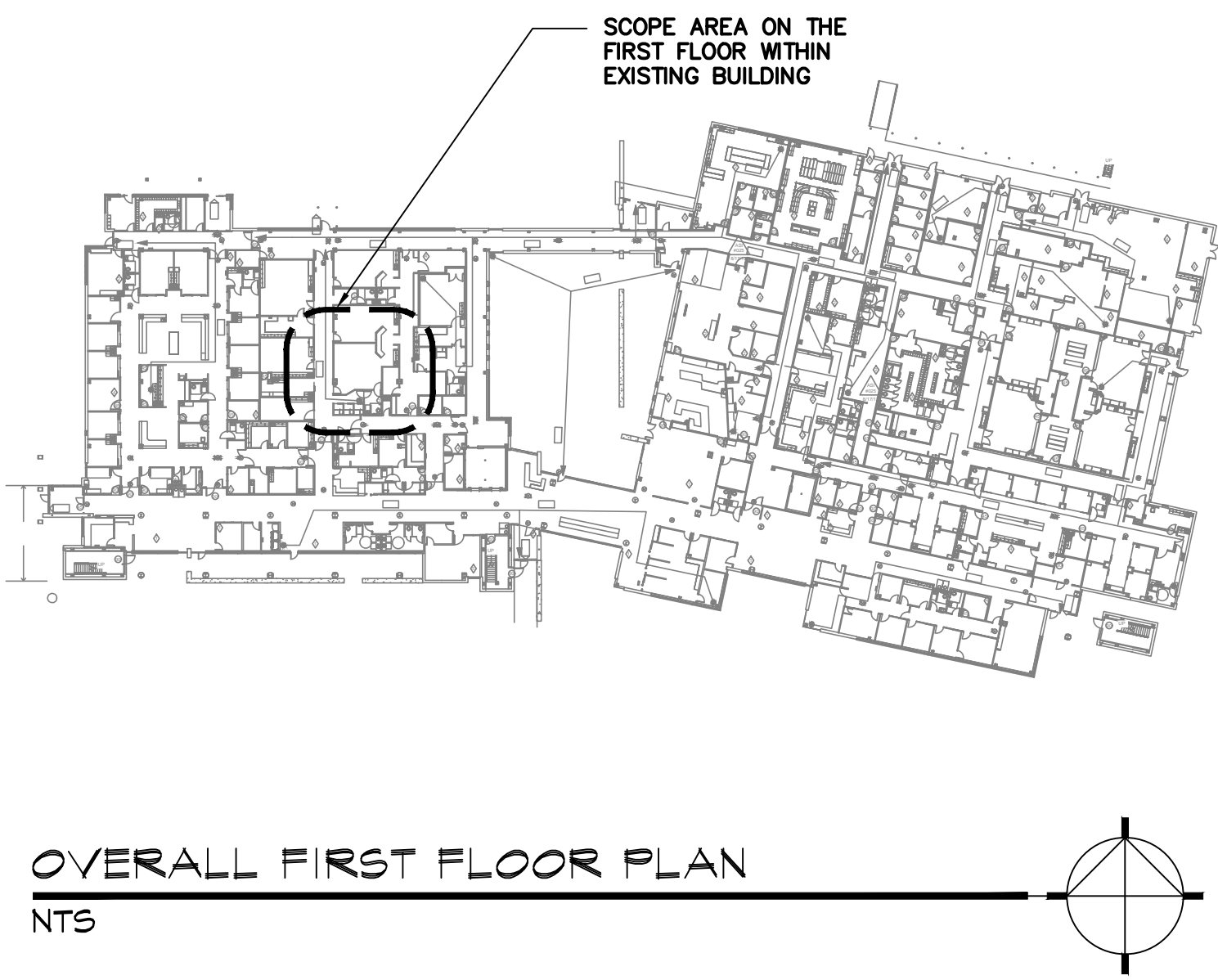

**NOTE**

THESE DRAWINGS ARE PREPARED PER ESTABLISHED INDUSTRY STANDARDS AND REPRESENT THE ENGINEERS DESIGN CONCEPT. THEY ARE NOT INTENDED TO PROVIDE EVERY DETAIL OR CONDITION REQUIRED TO CONSTRUCT THE BUILDING. THE CONTRACTOR THROUGH SUBMITTALS AND OTHER COORDINATION EFFORTS IS FULLY RESPONSIBLE FOR PROVIDING A COMPLETE AND OPERATIONAL BUILDING WHETHER INDICATED ON THE PLANS OR NOT.

ANDREW J YOUNGROSS, P.E.  
2522 S.E. COLUSA AVE.  
FORT ST. LUCIE, FLORIDA

HYAC  
PLUMBING  
ELECTRICAL

TEL: 561-900-2447  
FAX: 561-274-0222  
E-MAIL: andrew@aeffa.com

**C.D. HAIR ARCHITECT**  
8661 Lake Worth Road  
Lake Worth, FL  
AR96135

revision:

NORTH CAROLINA  
PROFESSIONAL  
SEAL  
048609  
ENGINEER  
ANDREW J. YOUNGROSS

An Interior Renovation for:  
**Harnett Health  
RAD Room 1318 Renovation**  
215 Brightwater Drive  
Lillington, North Carolina

job no. 23-016/23077  
principal: AJY/AA  
designer: RR  
file name:  
date: 08.10.23  
title:

1 | FP

**FINAL SUBMITTAL for construction**

**GENERAL HVAC NOTES**

1. ALL WORK SHALL COMPLY WITH THE 2018 EDITION OF THE INTERNATIONAL BUILDING CODE, MECHANICAL, ENERGY CONSERVATION, ACCESSIBILITY CODES, AND ALL LOCAL CODE AMENDMENTS.
2. CONTRACTOR SHALL VERIFY EXISTING CONDITIONS PRIOR TO BIDDING, ORDERING, FABRICATION OR INSTALLATION OF MATERIALS OR EQUIPMENT, IN ORDER TO PROVIDE A FULLY INTEGRATED MECHANICAL AND CONTROLS SYSTEMS WITH THE EXISTING ONES. ANY DISCREPANCY BETWEEN EXISTING CONDITIONS AND PLANS, OR ADDITIONAL CLARIFICATION REQUIRED SHALL BE BROUGHT TO THE ATTENTION OF ENGINEER PRIOR TO FINAL BIDDING AND WORK. SUBMISSION OF THE CONTRACTORS PROPOSAL SHALL BE CONSIDERED AS INDICATING SUCH KNOWLEDGE. ANY CHANGES RESULTING FROM CONFLICTS IN THE FIELD, WHICH WERE NOT BROUGHT TO THE ENGINEERS ATTENTION, ARE TO BE MADE BY THIS CONTRACTOR AT NO ADDITIONAL COST TO THE OWNER.
3. DO NOT SCALE DRAWINGS. VERIFY DIMENSIONS IN FIELD PRIOR TO COMMENCEMENT OF WORK. MECHANICAL PLANS ARE GENERAL, DIAGRAMMATIC IN NATURE, AND ARE TO BE READ IN CONJUNCTION WITH ARCHITECTURAL, PLUMBING, ELECTRICAL, FIRE SPRINKLER, STRUCTURAL AND INTERIOR DESIGNER PLANS AND SHALL BE CONSIDERED AS ONE SET OF DOCUMENTS. PROVIDE OFFSETS AND DEVIATIONS FROM WORK SHOWN ON THE DRAWINGS AS MAY BE NECESSARY TO FIT ACTUAL SPACE CONDITIONS AT NO ADDITIONAL COST TO THE OWNER. DUCTWORK CHANGES MAY BE MADE BY CONTRACTOR USING EQUIVALENT SIZED DUCT. CONTACT ENGINEER IF DUCT AREA WILL NOT FIT.
4. CONTRACTOR SHALL PROVIDE A COMPLETE MECHANICAL SYSTEM(S) AS DETAILED ON THE DRAWINGS AND SPECIFICATIONS. WORK CONSISTS OF PROVIDING ALL MATERIALS, EQUIPMENT, APPURTENANCES, ETC. REQUIRED FOR A COMPLETE SYSTEM(S). INCLUDE ANY INCIDENTAL APPARATUS, APPLIANCES, MATERIALS, LABOR, PERMITS, SERVICES, ETC. NECESSARY TO MAKE WORK COMPLETE AND READY FOR OPERATION. IT IS THE INTENT OF THE DRAWINGS AND SPECIFICATIONS TO CALL FOR COMPLETE, FINISHED WORK, TESTED, AND READY FOR OPERATION.
5. CONTRACTOR IS RESPONSIBLE FOR IDENTIFYING CONFLICTS IN THE DRAWINGS AND SPECIFICATIONS PRIOR TO BIDDING AND REPORTING CONFLICTS TO THE ENGINEER BEFORE BIDDING. ANY CHANGES RESULTING FROM CONFLICTS IN THE FIELD, WHICH WERE NOT BROUGHT TO THE ENGINEERS ATTENTION, ARE TO BE MADE BY THE CONTRACTOR AT NO ADDITIONAL COST TO THE OWNER.
6. CONTRACTOR SHALL GUARANTEE THE INSTALLATION AGAINST DEFECTS IN MATERIALS AND WORKMANSHIP WHICH MAY OCCUR UNDER NORMAL USAGE FOR A PERIOD OF ONE YEAR AFTER OWNER'S ACCEPTANCE. DEFECTS SHALL BE PROMPTLY REMEDIED WITHOUT COST TO THE OWNER.
7. CONTRACTOR SHALL SECURE AND PAY FOR ALL PERMITS, FEES, INSPECTION AND TESTS. CONTRACTOR SHALL OBTAIN PERMIT AND APPROVED SUBMITTALS PRIOR TO COMMENCEMENT OF WORK OR ORDERING EQUIPMENT. CONTRACTOR SHALL BE PRESENT FOR ALL INSPECTIONS OF HIS WORK BY REGULATORY AUTHORITIES.
8. CONTRACTOR SHALL PROVIDE RECORD DRAWINGS TO THE BUILDING OWNER AND ARCHITECT. DRAWINGS SHALL INCLUDE ALL ADDENDUM ITEMS, CHANGE ORDERS, ALTERATIONS, REROUTING, ETC.
9. CONTRACTOR SHALL PROVIDE INSURANCE FOR PROTECTION AGAINST PUBLIC LIABILITY AND PROPERTY DAMAGE FOR THE DURATION OF THE WORK.
10. ALL MATERIAL SHALL BE NEW OF U.S. MANUFACTURER OF GOOD QUALITY. ALL WORK SHALL BE PERFORMED AT INDUSTRY STANDARD QUALITY LEVEL BY CERTIFIED PROFESSIONALS. ALL EQUIPMENT SHALL BE UL OR ETL LISTED. ALL INSTALLATIONS SHALL COMPLY WITH ICC 2018, CH 3. GENERAL REGULATIONS. BUILDINGS LOCATED WITHIN 3,000 FT FROM THE OCEAN SHALL UTILIZE NON-FERROUS MATERIALS FOR ALL OUTDOOR EXPOSED SUPPORTS, STANDS, FASTENERS, ETC.
11. COORDINATE EXACT LOCATION OF ALL DIFFUSERS AND RETURNS WITH ARCHITECTURAL REFLECTED CEILING PLAN.
11. CONTRACTOR SHALL PROVIDE A WRITTEN REPORT OF THE EXISTING SUPPLY AND RETURN STATIC PRESSURES, TEMPERATURES, AND AIR FLOWS, AND BALANCE THE CFMS OF THE NEW DIFFUSERS TO THE EXISTING AIR FLOW.
12. CONTRACTOR SHALL INCLUDE COSTS NECESSARY (PART OF BID) TO MAKE ONE CHANGE IN EACH UNITS SHEAVE, BUSHINGS AND BELTS, BALANCING DAMPERS REQUIRED AND ANY OTHER DEVICES REQUIRED FOR THE CORRECT BALANCE OF THE SYSTEM AS REQUIRED BY THE TAB FIRM.
13. GENERAL CONTRACTOR SHALL VERIFY THAT THE AIR CONDITIONED SPACE IS SEALED WITH AN APPROVED AIR BARRIER ACCORDANCE WITH ICC-2018, SEC 402.5.1. MECHANICAL CONTRACTOR SHALL NOTIFY GENERAL CONTRACTOR, ARCHITECT AND ENGINEER IN WRITING OF ANY DISCREPANCIES PRIOR TO INSTALLATION OF ANY EQUIPMENT.
14. FURNISH AND INSTALL PIPE IDENTIFICATION MARKERS ON ALL PIPES AND EQUIPMENT INSTALLED UNDER THIS CONTRACT. MARKERS SHALL BE A MINIMUM OF 1-1/2" X 8" AND IDENTIFIED IN ACCORDANCE WITH THE BACKGROUND AND LETTER COLORS ISSUED BY THE AMERICAN NATIONAL STANDARDS INSTITUTE (ANSI). PIPING SHALL BE IDENTIFIED AS FOLLOWS: CHILLED WATER RETURN, CHILLED WATER SUPPLY, CONDENSATE, HOT WATER RETURN, HOT WATER SUPPLY, CONDENSER WATER RETURN, CONDENSER WATER SUPPLY, REFRIGERANT LIQUID, REFRIGERANT SUCTION, AND DIRECTIONAL ARROWS. ALL IDENTIFICATIONS MUST BE VISIBLE AT EQUIPMENT.

**GENERAL INSTALLATION NOTE**

1. IT SHALL BE UNDER THE GENERAL CONTRACTOR'S RESPONSIBILITY TO INVESTIGATE EXISTING CONDITIONS AND MODIFY EXISTING PIPE ROUTING OF PLUMBING, FIRE PROTECTION AND ELECTRICAL IN ORDER TO PROPERLY ALLOW SPACE FOR DUCTWORK ROUTING.

**A/C OPERATION DURING CONSTRUCTION**

THE USE OF NEW OR EXISTING AIR HANDLING UNITS DURING CONSTRUCTION IS PROHIBITED UNLESS APPROVED BY THE OWNER AND THE PROCEDURE SHOWN BELOW ARE FOLLOWED:

1. THE CONTRACTOR SHALL PROTECT THE INTERIOR OF ALL DUCTWORK AND AIR HANDLING UNITS FROM THE ACCUMULATION OF DIRT AND DUST USUALLY ASSOCIATED WITH THE FINISHING STAGES OF THE CONSTRUCTION WORK.
2. DUCTWORK STORED ON SITE AWAITING INSTALLATION SHALL BE CAREFULLY EXAMINED AND THOROUGHLY CLEANED BEFORE PLACEMENT IN ITS FINAL LOCATION. THE ENDS OF DUCTWORK SHALL BE CLOSED DURING CONSTRUCTION.
3. THE AIR HANDLING UNITS MAY BE ALLOWED TO OPERATE DURING FINISHING STAGES OF THE GENERAL WORK PROVIDED THAT THE PRE-FILTERS ARE IN PLACE AND THE ENDS OF ALL RETURN AIR INLETS ARE COVERED WITH ROLL-UP FILTER MATERIAL.
4. WHEN THE SPACE IS TURNED OVER TO THE OWNER, THE CONTRACTOR SHALL REMOVE ALL FILTERS USED DURING CONSTRUCTION AND REPLACE THEM WITH NEW FILTERS.
5. USE OF NEW AHU'S DURING CONSTRUCTION IS NOT ALLOWED.

**MECHANICAL LEGEND**

SYMBOL	DESCRIPTION
C.F.M.	CUBIC FEET PER MINUTE
	A = DIFFUSER TYPE, CFM = DIFFUSER AIR FLOW
	CEILING DIFFUSER - SUPPLY AIR
	CEILING DIFFUSER - RETURN AIR

**AIR DISTRIBUTION SCHEDULE**

TYPE	MFG	MODEL	PATTERN	DAMPER	MOUNTING	NECK	MODULE	MAX N.C.	MAX CFM	NOTES
A	TITUS	TMS-AA	4-WAY	O.B.D.	LAY-IN	SEE NOTE 2	24x24	30	-	1,2
R	TITUS	350 FL	RETURN	O.B.D.	LAY-IN	SEE NOTE 2	24x24	30	-	1,2

- NOTES
- 1) COORDINATE EXACT LOCATION IN THE FIELD.
  - 2) MATCH NECK SIZE WITH EXISTING FLEXIBLE DUCT SIZE. VERIFY IN THE FIELD.

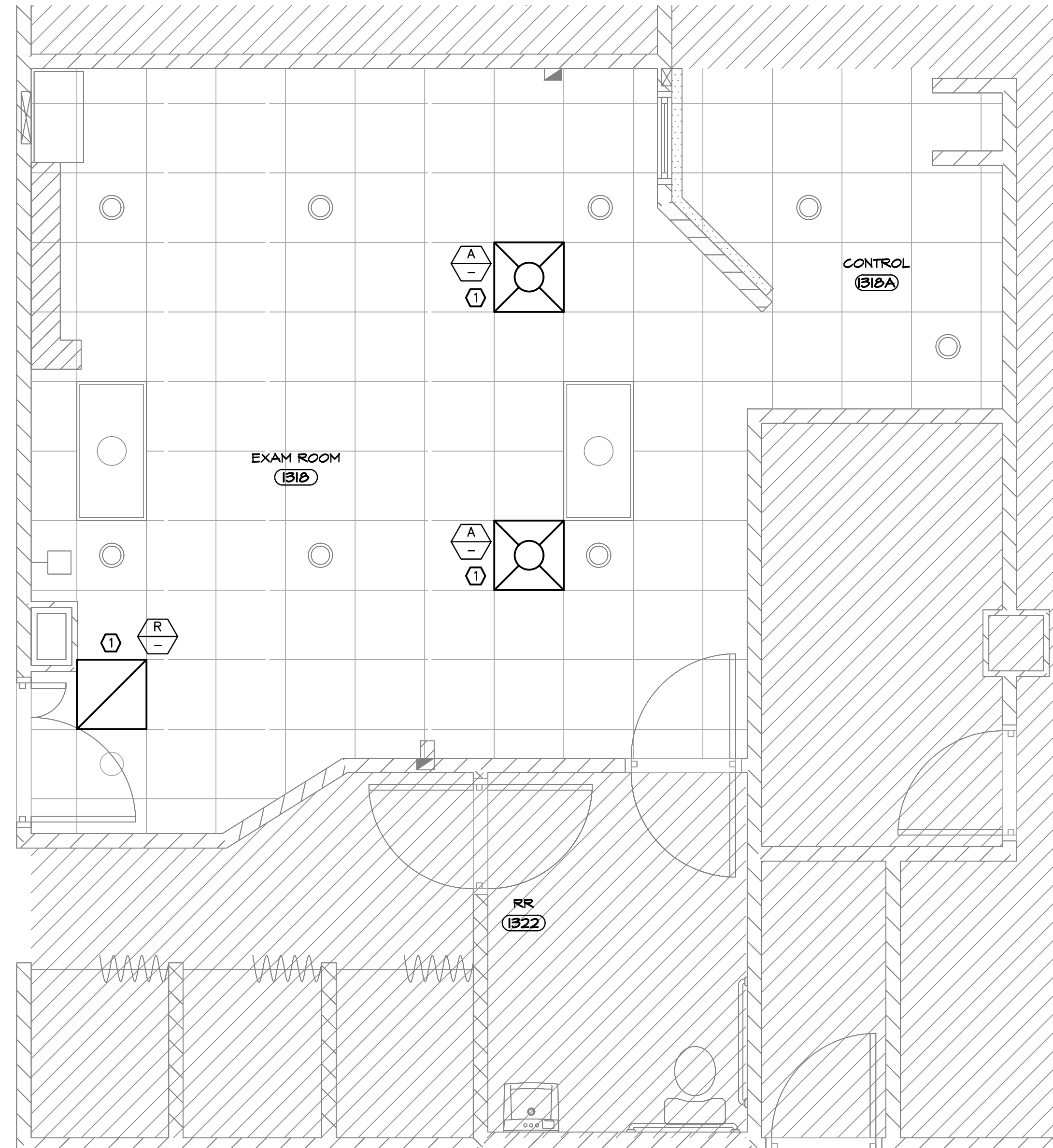

**FIRST FLOOR MECHANICAL PLAN**

3/8"=1'-0"

**PLAN KEY NOTES**

- 1) CONTRACTOR TO REMOVE EXISTING SUPPLY AND RETURN DIFFUSERS IN SCOPE OF WORK SPACE. CONTRACTOR TO INSTALL NEW SUPPLY AND RETURN DIFFUSERS IN EXISTING LOCATIONS AS PER SCHEDULE ON M1.1. CONNECT EXISTING FLEX DUCTWORK TO NEW DIFFUSERS. VERIFY EXISTING LOCATION IN THE FIELD.

SCOPE AREA ON THE FIRST FLOOR WITHIN EXISTING BUILDING

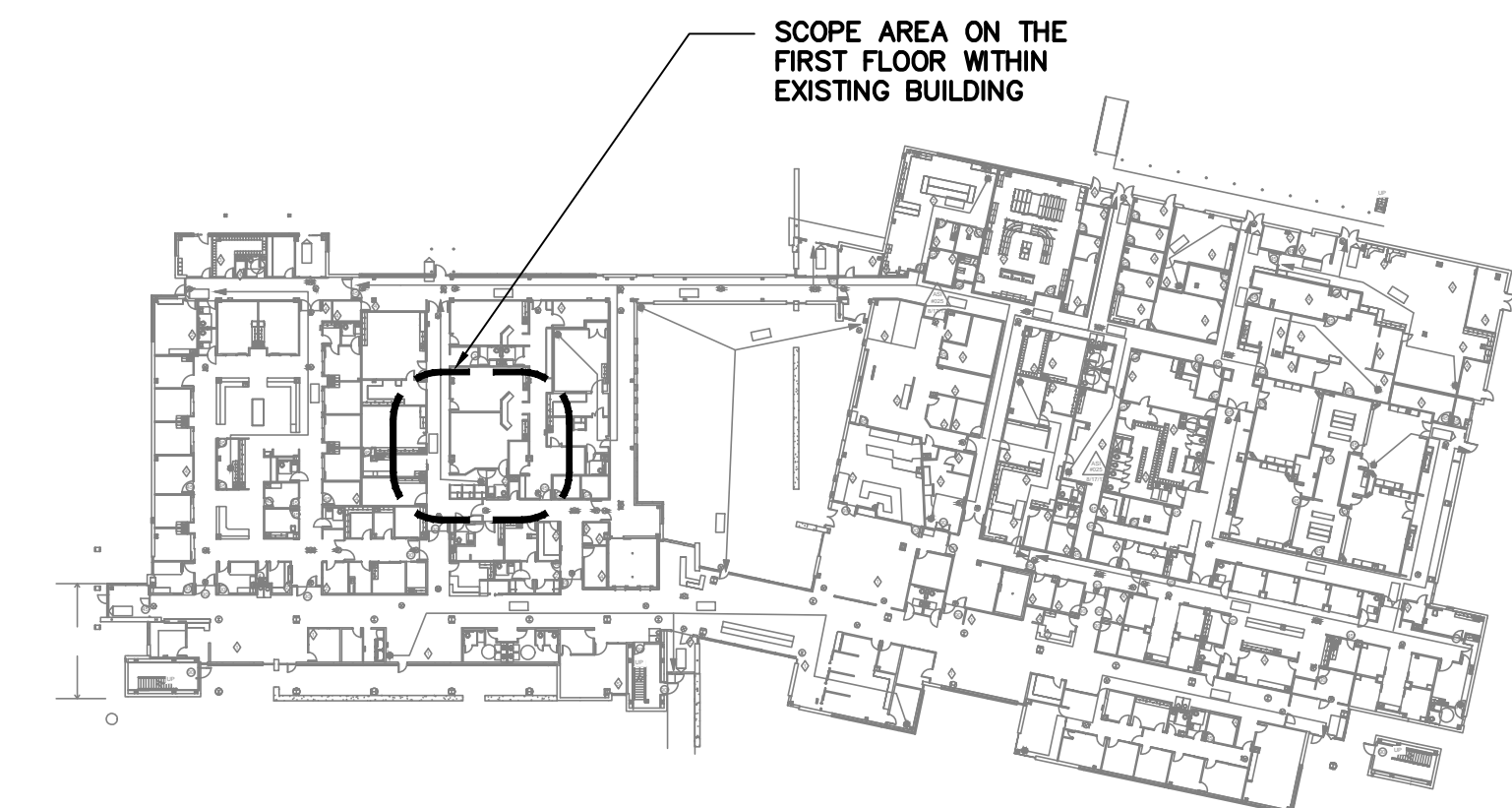

**OVERALL FIRST FLOOR PLAN**

NTS

**NOTE**

THESE DRAWINGS ARE PREPARED PER ESTABLISHED INDUSTRY STANDARDS AND REPRESENT THE ENGINEERS DESIGN CONCEPT. THEY ARE NOT INTENDED TO PROVIDE EVERY DETAIL OR CONDITION REQUIRED TO CONSTRUCT THE BUILDING. THE CONTRACTOR THROUGH SUBMITTALS AND OTHER COORDINATION EFFORTS IS FULLY RESPONSIBLE FOR PROVIDING A COMPLETE AND OPERATIONAL BUILDING WHETHER INDICATED ON THE PLANS OR NOT.

ANDREW J. YOUNGROSS, P.E.  
2522 S.E. COLUSA AVE.  
PORT ST. LUCIE, FLORIDA

TEL: 561-900-2447  
FAX: 561-274-0222  
E-MAIL: andrew@tecflo.com

HVAC  
PLUMBING  
ELECTRICAL

M1.1

1 M

C.D. HAIR ARCHITECT  
8661 Lake Worth Road  
Lake Worth, FL  
AR96135

revision:



An Interior Renovation for:  
**Harnett Health  
RAD Room 1318 Renovation**  
215 Brightwater Drive  
Lillington, North Carolina

job no. 23-016/23077  
principal: AJY/AA  
designer: RR  
file name:  
date: 08.10.23  
title:

**FINAL SUBMITTAL for construction**