

FIRE ALARM SUBMITTAL



113 Walter Street
Whiteville, NC 28472

www.tritekfire.com

Phone: (910) 207-6290
Columbia: (803) 407-0747
Florence: (843) 664-8811
Augusta, GA: (706) 722-4464
WATS SC/GA (888) 874-8353

12/10/2024

3266 Ray Road
Spring Lake, North Carolina



113 Walter Street
Whiteville, NC 28472

www.tritekfire.com

Phone: (910) 207-6290
Columbia: (803) 407-0747
Florence: (843) 664-8811
Augusta, GA: (706) 722-4464
WATS SC/GA (888) 874-8353

Table of Contents

Parts List	3
Distributor Documentation	5
Certifications	8
Data Sheets	12
Wire Submittal	42
Calculations	46

FIRE ALARM SUBMITTAL



113 Walter Street
Whiteville, NC 28472

www.tritekfire.com

Phone: (910) 207-6290
Columbia: (803) 407-0747
Florence: (843) 664-8811
Augusta, GA: (706) 722-4464
WATS SC/GA (888) 874-8353

PARTS LIST

FIRE ALARM SUBMITTAL



113 Walter Street
Whiteville, NC 28472

www.tritekfire.com

Phone: (910) 207-6290
Columbia: (803) 407-0747
Florence: (843) 664-8811
Augusta, GA: (706) 722-4464
WATS SC/GA (888) 874-8353

EQUIPMENT LIST

MANUFACTURER	MODEL #	DESCRIPTION
Fire_Lite	ES-200X	- Fire Alarm Control Panel
Fire_Lite	ANN-80-W	- 80 Char LCD serial annunciator, white
Starlink	SLE-MAXVI-CFB	- Dual Path Communicator, Cellular &/or IP
Fire_Lite	BG-12LX	- Addressable manual pull station
Fire_Lite	SD365	- Photoelectric Smoke Detector
Fire_Lite	DNRW	- Duct Detector with weatherproof housing
Fire_Lite	RA100Z	- Remote Indicator
Fire_Lite	CRF-300	- Addressable Relay Module
Fire_Lite	MDF-300	- Dual Monitor Module
System_Sensor	PC2RLED	- Horn/Strobe (ceiling mount)
System_Sensor	P2RLED	- Horn/Strobe (wall mount)
System_Sensor	SCRLED	- Strobe (ceiling mount)



113 Walter Street
Whiteville, NC 28472

www.tritekfire.com

Phone: (910) 207-6290
Columbia: (803) 407-0747
Florence: (843) 664-8811
Augusta, GA: (706) 722-4464
WATS SC/GA (888) 874-8353

DISTRIBUTOR DOCUMENTATION

TRITEK

Fire, Security & Communications

A Subsidiary of TriTek Fire & Security, LLC

WWW.TRITEKFIRE.COM

6 Woodcross Drive
Columbia, South Carolina 29212
Tel (803) 407-0747
Fax (803) 407-0779
Watts (888) 874-8353

1313 Walter Street
Whiteville, NC 28472
Tel (910) 207-6290

1212 Broad Street
Augusta, Georgia 30901
Tel (706) 722-4464
Fax (803) 407-0779

Thank you for selecting TriTek Fire, Security & Communications as the provider of your equipment and installation. Below is a list of items that should be reviewed and/or completed prior to the arrival of a TriTek Technician. Please keep in mind that if some aspects of system testing cannot be completed during the technicians scheduled on site dates (i.e. Devices not in place, wiring problems, or other trades not on site as needed to complete interconnection and testing) it is the responsibility of the contractor to notify TriTek when the technician will be required back on site. Please be aware that TriTek requires a five (5) business day notification in order to schedule/reschedule a technician.

Please review the following items

- All equipment provided by others trades that need to be monitored or controlled by the TriTek equipment is to be installed and ready for testing.
- Phone lines for Central Station monitoring installed and a monitoring account setup with either TriTek or other third party. (If other than TriTek all account information needs to be on hand)
- Fire Marshal Inspection (*requires a 5 business day notice to TriTek for technician scheduling*)
- DHEC Inspection (*requires a 5 business day notice to TriTek for technician scheduling*)
- Elevator Inspection (*requires a 5 business day notice to TriTek for technician scheduling*)
- Customer Training (*requires a 5 business day notice to TriTek for technician scheduling*)

TriTek's normal business hours are, Monday-Friday, 8am to 5pm, excluding holidays. If after hours testing/work is required this will be billable at TriTek's current hourly rate. A PO# will have to be received at our Columbia office before a technician can be authorized to work.

If you have any questions please contact your TriTek sales representative or TriTek Technical Installation Support.



Party Site No.: **636384**

Expires: **31-Dec-2024**

CERTIFICATE OF COMPLIANCE

THIS IS TO CERTIFY that the Alarm / Service Company identified below is included by - UL Solutions (UL) in its UL Product iQ directories as eligible to use the UL Listing Mark in connection with Certificated Systems. The only evidence of compliance with UL's requirements is the issuance of a UL Certificate for the System and the Certificate is active under UL's Certificate Verification Service. This Certificate does not apply in any way to the communication channel between the protected property and any facility that monitors signals from the protected property.

Listed Service From: COLUMBIA , SOUTH CAROLINA

Alarm / Service Company: (636384)

TRITEK FIRE & SECURITY L L C
6 WOODCROSS DR
COLUMBIA , South Carolina 29212-2331 UNITED STATES

The Alarm / Service Company is Listed in the following Certificate Service Categories:

<u>File</u>	<u>Vol No.</u>	<u>CCN</u>	<u>Listing Category</u>
S8930	1	UUFX	Central-station Protective Signaling Services



*****THIS CERTIFICATE EXPIRES ON 31-DEC-24*****

"LOOK FOR THE UL ALARM / SYSTEM CERTIFICATE"



113 Walter Street
Whiteville, NC 28472

www.tritekfire.com

Phone: (910) 207-6290
Columbia: (803) 407-0747
Florence: (843) 664-8811
Augusta, GA: (706) 722-4464
WATS SC/GA (888) 874-8353

CERTIFICATIONS



**NATIONAL INSTITUTE FOR CERTIFICATION
IN ENGINEERING TECHNOLOGIES®**

Providing Certification Programs Since 1961

BE IT KNOWN THAT

Raymond E. Stevens
IS HEREBY AWARDED THE FOLLOWING CERTIFICATION
Fire Alarm Systems Level IV

Certification Number **98485**

Valid Through **2026-05-01**

VERIFY ONLINE
nicet.org/verify

**BASED UPON SUCCESSFUL DEMONSTRATION OF REQUISITE KNOWLEDGE,
EXPERIENCE AND WORK PERFORMANCE AS SET FORTH BY THIS INSTITUTE.**

A handwritten signature in black ink that reads "Linda M. Biewacki".

CHAIR OF THE NICET BOARD OF GOVERNORS

A DIVISION OF THE NATIONAL SOCIETY OF PROFESSIONAL ENGINEERS



**NATIONAL INSTITUTE FOR CERTIFICATION
IN ENGINEERING TECHNOLOGIES®**

Providing Certification Programs Since 1961

BE IT KNOWN THAT

Raymond E. Stevens
IS HEREBY AWARDED THE FOLLOWING CERTIFICATION
Inspection and Testing of Fire Alarm
Systems Level II

Certification Number **98485**

Valid Through **2026-05-01**

VERIFY ONLINE
nicet.org/verify

**BASED UPON SUCCESSFUL DEMONSTRATION OF REQUISITE KNOWLEDGE,
EXPERIENCE AND WORK PERFORMANCE AS SET FORTH BY THIS INSTITUTE.**

A handwritten signature in black ink that reads "Linda M. Biewacki".

CHAIR OF THE NICET BOARD OF GOVERNORS

A DIVISION OF THE NATIONAL SOCIETY OF PROFESSIONAL ENGINEERS



**NATIONAL INSTITUTE FOR CERTIFICATION
IN ENGINEERING TECHNOLOGIES®**

Providing Certification Programs Since 1961

BE IT KNOWN THAT

James Adams

IS HEREBY AWARDED THE FOLLOWING CERTIFICATION

Fire Alarm Systems Level II

Certification Number **145546**

Valid Through **2026-08-01**

VERIFY ONLINE
nicet.org/verify

**BASED UPON SUCCESSFUL DEMONSTRATION OF REQUISITE KNOWLEDGE,
EXPERIENCE AND WORK PERFORMANCE AS SET FORTH BY THIS INSTITUTE.**

CHAIR OF THE NICET BOARD OF GOVERNORS

A DIVISION OF THE NATIONAL SOCIETY OF PROFESSIONAL ENGINEERS



113 Walter Street
Whiteville, NC 28472

www.tritekfire.com

Phone: (910) 207-6290
Columbia: (803) 407-0747
Florence: (843) 664-8811
Augusta, GA: (706) 722-4464
WATS SC/GA (888) 874-8353

DATA SHEETS

ES-200X**Intelligent Addressable FACP
with Communicator****Addressable Fire Alarm Control Panels****General**

The **ES-200X** is the latest intelligent addressable Fire Alarm Control Panel (FACP) from Fire-Lite Alarms. The ES-200X comes with a pre-installed communicator and supports up to 198 addressable devices (99 detectors and 99 modules). With an extensive list of powerful features, the ES-200X programs just like Fire-Lite's other addressable products, yet fits into applications previously served only by conventional panels.

The pre-installed IPOTS-COM is a dual technology (POTS and IP) communicator. The POTS transmits system status (alarms, troubles, AC loss, etc.) to a Central Station via the public switched telephone network. The IP communicator's internet monitoring capability sends alarm signals over the Internet saving the monthly cost of two dedicated business telephone lines. Although not required, the secondary telephone line may be retained providing backup communication over the public switched telephone line. Optional cellular reporting is available using the CELL-MOD or CELL-CAB-FL.

Remote and local programming of the control panel is possible using the FS-Tools Upload/Download utility. Programming databases can be uploaded/downloaded via the panel's USB port (and USB cable) or via an ethernet connection using the IPOTS-COM communicator. The USB port also allows for the download or upload of the entire program, history file, walk-test data, current status and system voltages by means of a USB flash drive.

The power supply and all electronics are contained on a circuit board supported on a new quick install chassis and housed in a metal cabinet. Available accessories include local and remote upload/download software, remote annunciators, and reverse polarity/city box transmitter (4XTMF).

Features

- Listed to UL Standard 864, 10th edition
- Pre-installed IPOTS-COM Ethernet IP and POTS (Plain Old Telephone Service) Central Station Communicator over AlarmNet
- Optional CELL-MOD or CELL-CAB-FL GSM Central Station Communicator over AlarmNet®
- Automated activation of the ECC-50/100 Emergency Command Center
- ECC-FFT Firefighter Telephone option
- Compatible with SWIFT® wireless devices
- Auto-programming (learn mode) reduces installation time. Reports two devices set to the same address
- Four built-in, independently programmable Style Z (Class A) or Style Y (Class B) NAC circuits
- Selectable strobe synchronization for System Sensor, Wheelock, and Gentex devices
- Notification Appliance Circuit End of Line resistor matching
- Four programmable function keys for ease of maintenance
- Two programmable relays and one fixed trouble relay
- Built-in Programmer
- Integral 80-character LCD display with backlighting
- Real-time clock/calendar with automatic daylight savings control
- History file with 1,000 event capacity
- Addressable sounder base compatibility
- Multi-criteria detector (smoke, heat, CO) with programmable response
- Control module delay timer
- Automatic detector sensitivity testing (NFPA 72 compliant)
- Automatic device type-code verification
- Point trouble identification
- Waterflow selection per module point
- Alarm verification selection per detector point



- Maintenance alert warns when smoke detector dust accumulation is excessive
- One-person audible or silent walk test with walk-test log and printout
- System alarm verification selection per detector point
- PAS (Positive Alarm Sequence) and Pre-signal per point (NFPA 72 compliant)
- Up to 16 ANN-BUS annunciators- 8 per each ANN-Bus
- Remote Acknowledge, Alarm Silence, Reset and Drill via addressable modules or remote annunciator
- Upload/Download of program and data via USB with optional FS-Tools Programming Utility

SLC COMMUNICATION LOOP

- Supports LiteSpeed™ and CLIP protocols
- SLC operates up to 10,000 ft. (3,000 m) in LiteSpeed mode with twisted, unshielded wire
- Single addressable SLC loop which meets NFPA Class B and Class A requirements
- 198 addressable device capacity (99 addressable detectors and 99 modules)
- Compatible with Fire-Lite's addressable devices (refer to the *SLC Wiring Manual*)

NOTIFICATION APPLIANCE CIRCUITS (NACS)

- Two independently programmable output circuits. Circuits can be configured for the following outputs:
 - **Style Y** (Class B)
 - **Style Z** (Class A)
 - Silence Inhibit and Autosilence timer options
 - Continuous, March Time, Temporal, or California code for main circuit board NACs with two-stage capability
 - Selectable strobe synchronization per NAC
 - 2.5 A special application, 250mA regulated, total power for NACs
- NOTE:** Maximum or total 24VDC system power shared between all NAC circuits and the ANN-BUS is 2.7 A

PROGRAMMING AND SOFTWARE

- Autoprogramming (learn mode) reduces installation time
- Custom English labels (per point) may be manually entered or selected from an internal library file
- Two programmable Form-C relay outputs
- 99 software zones
- Continuous fire protection during online programming
- Program Check automatically catches common errors not linked to any zone or input point
- **OFFLINE PROGRAMMING:** Create the entire program in your office using FS-Tools, a Windows®-based software package, and upload/download system programming locally. Offline programming requires an ethernet connection. FS-Tools is available on www.firelite.com.

User interface

LED INDICATORS

- Fire Alarm (red)
- CO Alarm (red)
- AC Power (green)
- Supervisory (yellow)
- Trouble (yellow)
- Ground fault (yellow)
- Battery fault (yellow)
- Disabled (yellow)
- Maintenance (yellow)
- Communication (yellow)
- Alarm Silenced (yellow)
- F1-F4 Programmable Function Keys (yellow)

KEYPAD

- 16 key alpha-numeric pad
- Acknowledge
- Alarm Silence
- Drill (Manual Evacuate)
- Four (4) programmable function keys
- Reset (lamp test)

PRODUCT LINE INFORMATION

ES-200X: Addressable Fire Alarm Control Panel with one SLC loop. Includes main circuit board with display, pre-installed communicator, chassis with transformer, backbox with door, plastic bag containing screws, cables, key, etc. (For ES-200XC, refer to DF-60958.)

FS-Tools: Programming software for Windows®-based PC computer. Available for download at www.firelite.com.

CELL-CAB-FL/CELL-MOD: Optional GSM communicators.

IPOTS-COM: Dual technology (POTS and IP) communicator. (replacement board)

DP-ES-R: Optional dress panel for the ES-200X.

TR-CE: Optional trim ring for semi-flush mounting.

BB-2F: Optional cabinet for one or two modules.

BB-6F: Optional cabinet for up to six modules mounted on CHS-6 chassis.

BB-26: Battery backbox, holds up to two 25 AH batteries and CHG-75.

BB-55F: Battery box, houses two 55 AH batteries

CHS-6: Chassis, mounts up to six multi-modules in a BB-6F cabinet.

CHG-75: Battery charger for lead-acid batteries with a rating of 25 to 75 AH.

CHG-120F: Remote battery charging system for lead-acid batteries with a rating of 55 to 120 AH. Requires additional BB-55F for mounting.

BAT Series: Batteries, see data sheet DF-52397.

PRN Series: UL listed compatible event printer. Uses tractor-fed paper.

OPTIONAL MODULES

4XTMF Reverse Polarity Transmitter Module: Provides a supervised output for local energy municipal box transmitter, alarm and trouble. Includes a disable switch and disable trouble LED.

PWRMOD24 Power Expander Module: Optional power module. Increases alarm power output to 6 amps.

COMPATIBLE ANNUNCIATORS

ANN-80: Remote LCD annunciator mimics the information displayed on the FACP LCD display. Recommended wire type is unshielded.

ANN-100: Remote LCD annunciator mimics the information displayed on the FACP LCD display. Recommended wire type is unshielded. For use in FM applications only.

ANN-I/O: LED Driver Module provides connections to a user supplied graphic annunciator. (See DF-52430.)

ANN-LED: Annunciator Module provides three LEDs for each zone: Alarm, Trouble, and Supervisory. Ships with red enclosure. (See DF-60241.)

ANN-RLED: Provides alarm (red) indicators for up to 30 input zones or addressable points. (See DF-60241.)

ANN-RLY: Relay Module provides 10 programmable Form-C relays. Can be mounted inside the cabinet. (See DF-52431.)

ANN-S/PG: Serial/Parallel Printer Gateway module provides a connection for a serial or parallel printer. (See DF-52429.)

ADDRESSABLE DEVICES

All feature a polling LED and rotary switches for addressing.

SD365: Addressable low-profile photoelectric smoke detector. LiteSpeed only.

SD365-IV: Addressable low-profile photoelectric smoke detector. Ivory. LiteSpeed and CLIP mode.

SD365T: Addressable low-profile photoelectric smoke detector with thermal sensor. LiteSpeed only.

SD365T-IV: Addressable low-profile photoelectric smoke detector with thermal sensor. Ivory. LiteSpeed and CLIP mode.

SD365R: Remote test capable addressable photoelectric smoke detector for use with DNR(W) duct detector housing. LiteSpeed only.

SD365R-IV: Remote test capable addressable photoelectric smoke detector for use with DNR(W) duct detector housing. Ivory. LiteSpeed and CLIP mode.

H365: Low-profile 135°F fixed thermal sensor. LiteSpeed only.

H365-IV: Low-profile 135°F fixed thermal sensor. Ivory. LiteSpeed and CLIP mode.

H365R: Low-profile, intelligent, rate-of-rise thermal sensor. LiteSpeed only.

H365R-IV: Low-profile, intelligent, rate-of-rise thermal sensor. Ivory. LiteSpeed and CLIP mode.

H365HT: Low-profile intelligent 190°F/88°C fixed thermal sensor. LiteSpeed only.

H365HT-IV: Low-profile intelligent 190°F/88°C fixed thermal sensor. Ivory. LiteSpeed and CLIP mode.

Legacy Devices

CP355: Addressable low-profile ionization smoke detector.

SD355: Addressable low-profile photoelectric smoke detector.

SD355T: Addressable low-profile photoelectric smoke detector with thermal sensor.

SD355R: Remote test capable addressable photoelectric smoke detector for use with DNR(W) duct detector housing.

SD355CO: Addressable, low-profile device that provides fire, heat, and carbon monoxide (CO) detection.

H355: Fast-response, low-profile heat detector.

H355R: Fast-response, low-profile heat detector with rate-of-rise option.

H355HT: Fast-response, low-profile heat detector that activates at 190°F/88°C.

AD355: Low-profile, intelligent, "Adapt" multi-sensor detector (B350LP base included).

B200SR: Addressable sounder base.

BEAM355: Intelligent beam smoke detector.

BEAM355S: Intelligent beam smoke detector with integral sensitivity test.

D355PL: InnovairFlex low-flow non-relay duct-detector housing; includes SD355R.

DNR: InnovairFlex low-flow non-relay duct-detector housing. (Order SD355R/SD365R separately.)

DNRW: InnovairFlex low-flow non-relay duct-detector housing, with NEMA-4 rating. Watertight. (Order SD355R/SD365R separately.)

Addressable Modules

MMF-300: Addressable Monitor Module for one zone of normally-open dry-contact initiating devices. Mounts in standard 4.0" (10.16 cm.) box. Includes plastic cover plate and end-of-line resistor. Module may be configured for either a Style B (Class B) or Style D (Class A) IDC.

MDF-300: Dual Monitor Module. Same as MMF-300 except it provides two Style B (Class B) only IDCs.

MMF-301: Miniature version of MMF-300. Excludes LED and Style D option. Connects with wire pigtailed. May mount in device backbox.

MMF-302: Similar to MMF-300. Addressable Monitor Module for one zone of conventional two-wire detectors. Requires resettable 24 VDC power. Refer to the *Device Compatibility Document* for listed compatible devices and quantity limitation.

CMF-300: Addressable Control Module for one Style Y/Z (Class B/A) zone of supervised polarized Notification Appliances. Mounts directly to a 4.0" (10.16 cm.) electrical box. NAC option requires external 24 VDC to power notification appliances.

CRF-300: Addressable relay module containing two isolated sets of Form-C contacts, which operate as a DPDT switch. Mounts directly to a 4.0" (10.16 cm.) box, surface mount using the SMB500.

BG-12LX: Addressable manual pull station with interface module mounted inside.

I300: This module isolates the SLC loop from short circuit conditions (required for Style 6 or 7 operation).

ISO-6: Six-fault isolator module. Mount one or two modules in a BB-2F cabinet (optional). Mount up to six modules on a CHS-6 chassis in a BB-6F cabinet.

SMB500: Used to mount all modules except the MMF-301 and M301.

MMF-300-10: Ten-input monitor module. Mount one or two modules in a BB-2F cabinet (optional). Mount up to six modules on a CHS-6 chassis in a BB-6F cabinet.

MMF-302-6: Six-zone interface module. Mount one or two modules in a BB-2F cabinet (optional). Mount up to six modules on a CHS-6 chassis in a BB-6F cabinet.

CMF-300-6: Six-circuit supervised control module. Mount one or two modules in a BB-2F cabinet (optional). Mount up to six modules on a CHS-6 chassis in a BB-6F cabinet.

CRF-300-6: Six-relay control module (Form-C relays). Mount one or two modules in a BB-2F cabinet (optional). Mount up to six modules on a CHS-6 chassis in a BB-6F cabinet.

SWIFT Wireless Devices

W-GATE: LiteSpeed Wireless Gateway

W-SD355: LiteSpeed intelligent, wireless photo detector.

W-H355R: LiteSpeed intelligent wireless rate of rise (135°) heat detector.

W-SD355T: intelligent wireless photo/heat detector.

W-H355: LiteSpeed intelligent wireless fixed-temperature (135°) heat detector.

W-MMF: LiteSpeed Intelligent wireless monitor module.

W-CRF: LiteSpeed Intelligent wireless relay module.

W-BG12LX: LiteSpeed Intelligent wireless pull station.

WAV-RL, WAV-WL, WAV-CRL, WAV-CWL: LiteSpeed Intelligent AV bases.

W-USB: Wireless USB radio/antenna dongle that plugs into the USB port of a PC running SWIFT Tools.

SWIFT Tools: Programming and diagnostic utility for the Wireless Gateway and devices. Available for download from firelite.com.

NOTE: For more information on Compatible Addressable Devices for use with the ES-200X, see the following data sheets (document numbers): SD365 Series (DF-61010), H365 Series (DF-61011), AD355 (DF-52386), BG-12LX (DF-52013), CMF-300-6 (DF-52365), CRF-300-6 (DF-52374), CMF/CRF Series (DF-52130), CP355 (DF-52383), H355 Series (DF-52385), I300 (DF-52389), ISO-6 (DF-60485), MMF-300 Series/MDF-300 (DF-52121), MMF-300-10 (DF-52347), MMF-302-6 (DF-52356), SD355/SD355T (DF-52384), and SLC Wiring Manual (51309).

NOTE: Legacy 300 Series detection devices such as the CP300/CP350, SD300(T)/SD350(T) and older modules such as the M300, M301, M302, C304, and BG-10LX are not compatible with LiteSpeed polling. If the SLC contains one of these devices, polling must be set for standard CLIP protocol. Please consult factory for further information on previous 300 Series devices.

ADDRESSABLE DEVICE ACCESSORIES

End-of-Line Resistor Assembly (R-47K and R-3.9K): The 47k ohm assembly supervises the MMF-300, MDF-300, MMF-301, and CMF-300 module circuits. The 3.9k ohm assembly supervises the MMF-302 module circuit. These resistors are included with each module.

Power Supervision Relay: Supervises the power to 4-wire smoke detectors and notification appliances.

Wiring Requirements

While shielded wire is not required, it is recommended that all SLC wiring be twisted-pair to minimize the effects of electrical interference. Refer to the panel manual for wiring details.

SYSTEM SPECIFICATIONS

System Capacity

- Intelligent Signaling Line Circuits..... 1
- Addressable device capacity 198
- Programmable software zones 99
- Annunciators..... 16

Electrical Specifications

AC Power: 120/240 VAC, 50/60 Hz, 3.25 A. Wire size: minimum 14 AWG (2.00 mm²) with 600 V insulation. Nonpower-limited, supervised.

Battery: Two 12 V 18 AH lead-acid batteries. Battery Charger Capacity: 7-18 AH (ES-200X cabinet holds maximum of two 18 AH batteries.)

Communication Loop: Supervised and power-limited.

Notification Appliance Circuits: Terminal Block provides connections for four NACs, Style Y (Class B) or Style Z (Class A). Special Application power. Power-limited, supervised circuitry. Maximum signaling current per circuit: 2.5 amps special application, 250mA regulated. End-of-Line Resistor: 4.7k ohm, ½ watt (P/N 71252 UL listed) for Style Y (Class B) NAC; system capable of 1.9 kΩ - 22 kΩ ELR range. Refer to the *Fire•Lite Device Compatibility Document* for listed compatible devices.

Two Programmable Relays and One Fixed Trouble Relay: Contact rating: 2.0 A @ 30 VDC (resistive), 0.5 A @ 30 VAC (resistive). Form-C relays, non-power-limited, non-supervised.

Cabinet Specifications

Door: 19.26" (48.92 cm.) high x 16.82" (42.73 cm.) wide x 0.72" (1.82 cm.) deep. **Backbox:** 19.00" (48.26 cm.) high x 16.65" (42.29 cm.) wide x 5.25" (13.34 cm.) deep. **Trim Ring (TR-CE):** 22.00" (55.88 cm.) high x 19.65" (49.91 cm.) wide.

Shipping Specifications

Weight: 26.9 lbs. (12.20 kg.) **Dimensions:** 20.00" (50.80 cm.) high x 22.5" (57.15 cm.) wide x 8.5" (21.59 cm.) deep.

Temperature and Humidity Ranges

NFPA Standards

The ES-200X complies with the following NFPA 72 Fire Alarm Systems requirements:

- **LOCAL** (Automatic, Manual, Waterflow and Sprinkler Supervisory).
- **AUXILIARY** (Automatic, Manual and Waterflow) (requires 4XTMF).
- **REMOTE STATION** (Automatic, Manual and Waterflow) (Where a DACT is not accepted, the alarm, trouble and supervisory relays may be connected to UL 864 listed transmitters. For reverse polarity signaling of alarm and trouble, 4XTMF is required.)
- **PROPRIETARY** (Automatic, Manual and Waterflow).
- **CENTRAL STATION** (Automatic, Manual and Waterflow, and Sprinkler Supervised).
- **OT, PSDN** (Other Technologies, Packet-switched Data Network)
- **IBC 2012, IBC 2009, IBC 2006, IBC 2003, IBC 2000** (Seismic).
- **CBC 2007** (Seismic)

Agency Listings and Approvals

The listings and approvals below apply to the basic ES-200X control panel. In some cases, certain modules may not be listed by certain approval agencies, or listing may be in process. Consult factory for latest listing status.

- **UL:** S624

NOTE: See DF-60958 for ULC-listed model.

AlarmNet®, Fire-Lite® Alarms, SWIFT®, and System Sensor® are registered trademarks of Honeywell International Inc. Microsoft® and Windows® are registered trademarks of the Microsoft Corporation.

©2018 by Honeywell International Inc. All rights reserved. Unauthorized use of this document is strictly prohibited.

This document is not intended to be used for installation purposes.
We try to keep our product information up-to-date and accurate.
We cannot cover all specific applications or anticipate all requirements.
All specifications are subject to change without notice.



For more information, contact Fire•Lite Alarms. Phone: (800) 627-3473, FAX: (877) 699-4105.
www.firelite.com



Assembled in the USA

ANN-80

80-Character LCD Serial Annunciator



Annunciators

General

The ANN-80 annunciator is a compact, backlit, 80-character LCD fire annunciator that mimics the Fire Alarm Control Panel (FACP) display. It provides system status indicators for AC Power, Alarm, Trouble, Supervisory, and Alarm Silenced conditions. The ANN-80 and the FACP communicate over a two-wire serial interface employing the ANN-BUS communication format. Connected devices are powered, via two additional wires, by either the host FACP or a remote UL-listed, filtered power supply. ANN-80 is red; for white, order ANN-80-W.

The ANN-80 displays English-language text of system point information including device type, zone, independent point alarm, trouble or supervisory status, as well as any custom alpha labels programmed into the control panel. It includes control switches for remote control of critical system functions. (A keyswitch prevents unauthorized operation of the control switches.)

Up to eight ANN-80s may be connected to the ANN-BUS of each FACP. No programming is required, which saves time during system commissioning.

Features

- Listed to UL Standard 864, 9th Edition.
- Backlit 80-character LCD display (20 characters x 4 lines).
- Mimics all display information from the host panel.
- Control switches for System Acknowledge, Signal Silence, Drill, and Reset.
- Control switches can be independently enabled or disabled at the FACP.
- Keyswitch enables/disables control switches and mechanically locks annunciator enclosure
- Keyswitch can be enabled or disabled at the FACP.
- Enclosure supervised for tamper.
- System status LEDs for AC Power, Alarm, Trouble, Supervisory, and Alarm Silence.
- Local sounder can be enabled or disabled at the FACP.
- ANN-80 connects to the ANN-BUS terminal on the FACP and requires minimal panel programming.
- Displays device type identifiers, individual point alarm, trouble, supervisory, zone, and custom alpha labels.
- Time-and date display field.
- Surface mount directly to wall or to single, double, or 4" square electrical box.
- Semi-flush mount to single, double, or 4" square electrical box. Use ANN-SB80KIT for angled view mounting.
- Can be remotely located up to 6,000 feet (1,800 m) from the panel.
- Backlight turns off during AC loss to conserve battery power but will turn back on if an alarm condition occurs.
- May be powered by 24 VDC from the host FACP or by remote power supply (requires 24 VDC).
- Up to eight ANN-80s can be connected on the ANN-BUS.

Controls and Indicators

- AC Power
- Alarm
- Trouble



52417 cov.jpg

- Supervisory
- Alarm Silenced

Specifications

- **Operating voltage range:** 18 VDC to 28 VDC.
- **Current consumption @ 24 VDC nominal** (filtered and non-resettable): 40 mA maximum.
- **Ambient temperature:** 32°F to 120°F (0°C to 49°C).
- **Relative humidity:** 93% ± 2% RH (noncondensing) at 32°C ± 2°C (90°F ± 3°F).
- 5.375" (13.65 cm.) high x 6.875" (17.46 cm.) wide x 1.375" (3.49 cm.) deep.
- For use indoors in a dry location.
- All connections are power-limited and supervised.

Agency Listings and Approvals

The listings and approvals below apply to the ANN-80. In some cases, certain modules may not be listed by certain approval agencies, or listing may be in process. Consult factory for latest listing status.

- **UL:** S2424
- **FM approved**
- **CSFM:** 7120-0075:211
- **MEA:** 442-06-E

The ANN-BUS

POWERING THE DEVICES ON THE ANN-BUS FROM AUXILIARY POWER SUPPLY

The ANN-BUS can be powered by an auxiliary power supply when the maximum number of ANN-BUS devices exceeds the ANN-BUS power requirements. See the FACP manual for more information.

ANN-BUS DEVICE ADDRESSING

Each ANN-BUS device requires a unique address (ID Number) in order to communicate with the FACP. A maximum of 8 devices can be connected to the FACP ANN-BUS communication circuit. See the FACP manual for more information.

WIRE REQUIREMENTS: COMMUNICATIONS CIRCUIT

The ANN-80 connects to the FACP ANN-BUS communications circuit. To determine the type of wire and the maximum wiring distance that can be used with FACP ANN-BUS accessory modules, it is necessary to calculate the total worst case current draw for all modules on a single 4-conductor bus. The total worst case current draw is calculated by adding the individual worst case currents for each module.

NOTE: For total worst case current draw on a single ANN-BUS refer to appropriate FACP manual.

After calculating the total worst case current draw, the following table specifies the maximum distance the modules can be located from the FACP on a single wire run. The table ensures 6.0 volts of line drop maximum. In general, the wire length is limited by resistance, but for heavier wire gauges, capacitance is the limiting factor.

These cases are marked in the chart with an asterisk (*). Maximum length can never be more than 6,000 feet (1,800 m), regardless of gauge used. See table below.

WIRE REQUIREMENTS: POWER CIRCUIT

- 14 to 18 AWG (0.75 - 2.08 mm²) wire for 24 VDC power circuit is acceptable. Power wire distance limitation is set by 1.2 volt maximum line drop from source to end of circuit.
- All connections are power-limited and supervised.
- A maximum of eight ANN-80 modules may be connected to this circuit.

Communication Pair Wiring Distance: FACP to Last ANN-BUS Module				
Total Worst Case Current Draw (amps)	22 Gauge	18 Gauge	16 Gauge	14 Gauge
0.100	1,852 ft.	4,688 ft.	* 6,000 ft.	*6,000 ft.
0.200	926 ft.	2,344 ft.	3,731 ft.	5,906 ft.
0.300	617 ft.	1,563 ft.	2,488 ft.	3,937 ft.
0.400	463 ft.	1,172 ft.	1,866 ft.	2,953 ft.
0.500	370 ft.	938 ft.	1,493 ft.	2,362 ft.
0.600	309 ft.	781 ft.	1,244 ft.	1,969 ft.
0.700	265 ft.	670 ft.	1,066 ft.	1,687 ft.
0.800	231 ft.	586 ft.	933 ft.	1,476 ft.
0.900	206 ft.	521 ft.	829 ft.	1,312 ft.
1.000 (max.)	185 ft.	469 ft.	746 ft.	1,181 ft.

WIRING CONFIGURATION

The following figure illustrates the wiring between the FACP and ANN-BUS devices.

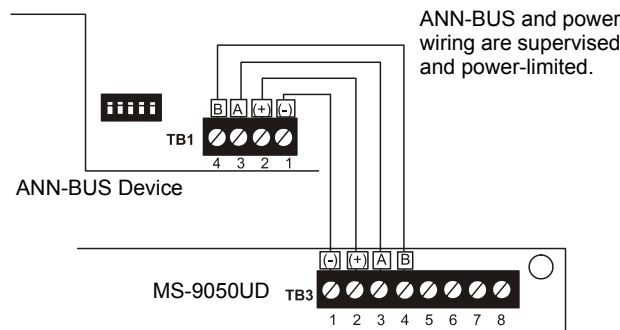

FACP Wiring to ANN-BUS Device

ORDERING OPTIONS:

- ANN-80:** Red 80 character LCD Annunciator.
- ANN-80-W:** White, 80 character LCD Annunciator.
- ANN-SB80KIT-R:** Red surface mount backbox with angled wedge.
- ANN-SB80KIT-W:** White surface mount backbox with angled wedge.

FireLite® Alarms is a registered trademark of Honeywell International Inc. ©2009 by Honeywell International Inc. All rights reserved. Unauthorized use of this document is strictly prohibited.



This document is not intended to be used for installation purposes. We try to keep our product information up-to-date and accurate. We cannot cover all specific applications or anticipate all requirements. All specifications are subject to change without notice.



For more information, contact Fire•Lite Alarms. Phone: (800) 627-3473, FAX: (877) 699-4105. www.firelite.com

StarLink^{MAX} FIRE



5G LTE-M Universal Commercial Fire Alarm Cellular &/or IP Communicators

- **Universal full event sole & dual path 5G LTE-M cellular &/or IP commercial fire alarm reporting from any panel brand, virtually anywhere nationwide**
- **Code-compliant, replaces 2 POTs lines per FACP &** saves thousands of dollars per year over the leased landlines.
- **Supports 12V-24V control panels and FACPs** that communicate using Contact ID and 4/2 (such as on legacy panels).
- **Proven StarLink Reliability & Best 5G LTE-M Performance - Works where others can't** - Signal Boost™ Circuitry & unique dual-diversity twin antennas, maximizing signal acquisition and eliminating the multiphase-effect signal-clash/drop-outs single-antenna units are prone to.
- **Full Data Reporting to any Central Station nationwide, via choice of Verizon® or AT&T® Networks.** Communicate critical life and safety alarm reports for maximum life safety & liability protection.
- **Easiest installation, powered by panel, NO extra power supply, NO extra conduit.** (Excludes Metal Enclosure Direct AC-Powered models)
- **Labor-Saving Features Save Time & Money** - Uniquely includes 4 programmable EOLR zone inputs; 2 Form C Relay outputs (no extra supervision modules to buy or install); plus, 2 Telephone style jacks for easy FACP-connection. Self-supervised on 4 wires.
- **Preactivated** - No-Delay Activation speeds installation time, even during peak periods.
- **LED Status/Trouble Indicators** 3 Radio Status LED Indicators (visible from outside standard model housing) - Green, Signal Strength; Amber- Busy/Activation; Red-Trouble (4 additional LEDs, not visible, for network status & troubleshooting). Power LED indicator viewable on outer metal enclosure models.
- **Over-the-Air Upgradeable Firmware** for updates w/o a truck-roll.
- **Free FACP-Saver App** - Smartphone Pro Sales Tool for calculating /demonstrating account's cellular cost-savings with dealer by number of lines & locations vs. copper POTs lines leased from phone co. **FREE download** on Apple Store or Google Play.



StarLink Max Fire 5G LTE-M code-compliant standard or metal models on choice of Verizon or AT&T networks



UL and NFPA 72 Fire Code-Compliant, the StarLink Max Fire Series Wireless Commercial Fire Alarm Sole Path & Dual Path Communicators provide universal support for any brand 12V to 24V fire alarm control panel, reporting in Contact ID and 4/2. With broadest nationwide coverage footprint, Verizon or AT&T, using proven StarLink circuitry, they are also available in locking metal enclosure models. All provide the most economical solution for easy, versatile installations. Also regional compliances, i.e., CSFM, NYC FD, LAFD and more.

Easy, Universal Installation at Every Application; Panel-Powered Technology™. StarLink Fire Communicators are easily connected to any panel or Fire Alarm Control Panel (FACP) standardly operating between 12V and 24V. Flexible in any application, StarLink Max Fire also comes in standard, or models in metal housings, with code-compliant supervision, and choice of power options, Panel-Powered Technology™ (powered by the panel), or direct-connect 120VAC models. Signal Boost circuitry & dual diversity antennas for maximum signal acquisition & null avoidance, receiving signals simultaneously on both antennas.

One Model is Sole or Dual Path with Cellular + Internet Option. StarLink Fire provides full data reporting, both Sole Path and Dual Path communication modes, as primary Communicators, to any central station of your choice, without requiring any special equipment on premises. The units are very easily activated, plans and options are selected, and 24/7 account management is provided all through www.napcocomnet.com.

Napco StarLink Max® Fire Commercial Alarm Communicators

- **5G LTE-M Sole or Dual Path Cell Commercial Fire Alarm Communicator**
- **Choice of Nationwide Coverage Networks**, Verizon or AT&T
- **Choice of plans for every requirement:** Simply select Cell or Cell/IP Service Plan and check-in period: 200 seconds, 5 minutes, 60 minutes, 6 hours or 24 hours.
- **Patented Signal Boost™ and Dual Diversity Antennae** for maximum signal acquisition & null avoidance, receiving signals simultaneously on both antennas
- **Pro Cost-Saver Tradeup Program** - Unsurpassed savings, for new and retrofit installations, replacing POTS, old radios, sunset networks and even new installations!

AGENCY LISTINGS



- UL 864 Standard For Control Units & Accessories For Fire Alarm Systems, 10th Edition
- UL 1610 Standard For Central-Station Burglar-Alarm Units
- UL 985 Standard For Household Fire Warning System Units
- UL 1023 Standard For Household Burglar-Alarm System Units
- UL 1076 APOU Proprietary Alarm Systems
- UL 365 APAAW Police Connect



NFPA 72 Editions 2019, 2016, 2013, 2010, 2007

California State Fire Marshal, NYC FD



Napco Addressable, Conventional Fire Alarm Systems & Leading Commercial Fire Cellular Communications

Model Ordering & Specifications

Model	LTE-M Network	Cell	IP	WiFi Option**	Unique Onboard Labor/Cost-Saver Features	Electrical Input Ratings	Inputs	Input Ratings	Outputs	Output Ratings	Other Power Supply (Option)††
STANDARD CELL &/OR IP MODELS (ABS) 5.38 x 7.88 x 1.88" (HWD)											
SLE-MAXAI-FIRE		Yes	Yes	Yes	2 TelCo jacks for EZ FACP Connect; 4 Programmable EOLR zone inputs; 2 Form C Relay outputs (avoids req't for supervision module)	Panel-Powered Tech'y: †† Input Voltage: 10-24VDC; Input Current: 115mA to 85mA standby; 325mA peak during transmissions	IN1, IN2, IN3, IN4, IN5	IN1: 9-25VDC Max Input Current: Up to 2mA from FACP NAC circuit IN2, IN3, IN4, IN5: 9-25VDC Max loop current 1.7mA	OUT1, OUT2, PGM3	OUT1, OUT2: Dry Contact, Form C Relay, 30V AC/DC, 500mA Max. PGM3 Open Collector Output Max 25VDC, Max 25V when not active. Max current 25mA@ 25V	
SLE-MAXVI-FIRE		Yes	Yes	Yes							
CELL &/OR IP MODELS IN METAL ENCLOSURE 9.63 x 11.75 x 3.38" (HWD)											
SLE-MAXAI-CFB		Yes	Yes	Yes	2 TelCo jacks for EZ FACP Connect; 4 Programmable EOLR zone inputs; 2 Form C Relay outputs (avoids req't for supervision module)	Panel-Powered Tech'y: †† Input Voltage: 10-24VDC; Input Current: 115mA to 85mA standby; 325mA peak during transmissions	IN1, IN2, IN3, IN4, IN5	IN1: 9-25VDC Max input current 2mA IN2, IN3, IN4, IN5 25VDC Max, 1.2mA Max Loop Current	OUT1, OUT2, PGM3	OUT1, OUT2: Dry Contact, Form C Relay, 30V AC/DC, 500mA Max. PGM3 Open Collector Output Max 25VDC, Max 25V when not active. Max current 25mA@ 25V	
SLE-MAXVI-CFB		Yes	Yes	Yes							
SLE-MAXAI-CFBPS		Yes	Yes	Yes	2 TelCo jacks for EZ FACP Connect; 4 Programmable EOLR zone inputs; 2 Form C Relay outputs (avoids req't for supervision module)	Direct AC-Powered: Input Voltage: 120VAC nominal; Input Current: 200mA max; maximum charging current: 200mA	IN1, IN2, IN3, IN4, IN5	IN1: 9-25VDC Max input current 2mA IN2, IN3, IN4, IN5 25VDC Max, 1.2mA Max Loop Current	OUT1, OUT2, PGM3	OUT1, OUT2: Dry Contact, Form C Relay, 30V AC/DC, 500mA Max. PGM3 Open Collector Output Max 25VDC, Max 25V when not active. Max current 25mA@ 25V	Transformer (TRF12/ T123 16.5V / 20VA Transformer)
SLE-MAXVI-CFBPS		Yes	Yes	Yes							

ACCESSORIES:

SLE-WIFI-MODULE Optionally connects supported dual path models to Internet via WiFi, eliminating Ethernet cable connection. Requires 7AH battery. (**See details W12191)

SLE-ANTEXT Optional extended range StarLink OMNI antenna w/ varying lengths of 'premium low-loss cable , from 4' to 100', & full mounting hardware & ground fault isolation mounting plate (cable length is added to part no. as suffix.)

TRF12 Optional Plug in AC Transformer, 16.5V / 20VA (use is subject to local code compliance)††

GEM-TAMPERKIT Tamper switches and screws to protect metal housing.

SLE-ULPS-R Power Supply option, for installations where FACP cannot provide Aux Power.

Also Available: Award-Winning FireLink™ Integrated Fire Alarm Control Panels, Addressable or Conventional w/ StarLink Fire Built In



FIRELINK FL SERIES in Original 32 Zone or XL255 Addressable cloud-programmable models

Firewolf 24V Addressable XL or Conventional Commercial Fire Alarm Control Panels offer up to 255 or 32 zones, with onboard StarLink Fire® Dual Path Cell/IP Alarm Communicator and integral menu-driven LCD annunciator. XL Model with larger enclosure supports up to 4ea 2A NAC circuits and 7A Power supply. Original 32-Zone Conventional model w/ up to 2ea 2A NAC circuits, 4amp, 24V power supply. Optionally expandable via commercial addressable or conventional fire devices. Locking, metal red enclosure, (surface or flush mount) removable door. XL255 model supports 4pair 8Ah batteries; 32 zone supports 2 pairs.

Note: Always consult technical manuals (W12465 and W12466) and/or AHJ for compliance requirements for your area/application. StarLink, StarLink Fire, FireLink, SignalBoost, Panel-Powered Technology, Gemini & Gemini Commercial are trademarks of Napco. AT&T, Verizon are trademarks of their respective companies. *StarLink offers full data coverage in US from virtually all panel brands reporting in Contact ID or 4/2. †† For Panel-Powered technology, regulated auxiliary power outputs are required on Listed FACP. **Add 45mA to input current Standby Battery requirement. ††Where permitted by AHJ; requires conduit. For full details on the StarLink tradeup incentive see online under <http://www.napcosecurity.com/starlink/starlink4gupgrade/> ††Promo subject to change w/o prior notice. NAPCO Security Technologies Inc. (NASDAQ:NSSC) A823 7/2022

BG-12LX

Addressable Manual Pull Station



Addressable Devices

General

The Fire-Lite BG-12LX is a state-of-the-art, dual-action (i.e., requires two motions to activate the station) pull station that includes an addressable interface (mounted inside) for Fire-Lite's addressable fire alarm control panels (FACPs). Because the BG-12LX is addressable, the control panel can display the exact location of the activated manual station. This leads fire personnel quickly to the location of the alarm.

Features

- Maintenance personnel can open station for inspection and address setting without causing an alarm condition.
- Built-in bicolor LED, which is visible through the handle of the station, flashes in normal operation and latches steady red when in alarm.
- Handle latches in down position and the word "ACTIVATED" appears to clearly indicate the station has been operated.
- Captive screw terminals wire-ready for easy connection to SLC loop (accepts up to 12 AWG/3.25 mm² wire).
- Can be surface mounted (with SB-10 or SB-I/O) or semi-flush mounted. Semi-flush mount to a standard single-gang, double-gang, or 4" (10.16 cm) square electrical box.
- Smooth dual-action design.
- Meets ADAAG controls and operating mechanisms guidelines (Section 4.1.3[13]); meets ADA requirement for 5 lb. maximum activation force.
- Highly visible.
- Attractive shape and textured finish.
- Key reset.
- Includes Braille text on station handle.
- Optional trim ring (BG12TR).
- Meets UL 38, Standard for Manually Actuated Signaling Boxes.

Construction

Shell, door, and handle are molded of durable polycarbonate material with a textured finish.

Specifications

- **Shipping Weight:** 9.6 oz. (272.15 g)
- **Normal operating voltage:** 24 VDC.
- **Maximum SLC loop voltage:** 28.0 VDC.
- **Maximum SLC standby current:** 375 μ A.
- **Maximum SLC alarm current:** 5 mA.
- **Temperature Range:** 32°F to 120°F (0°C to 49°C)
- **Relative Humidity:** 10% to 93% (noncondensing)
- **For use indoors in a dry location**

Installation

The BG-12LX will mount semi-flush into a single-gang, double-gang, or standard 4" (10.16 cm) square electrical outlet box, or will surface mount to the model SB-10 or SB-I/O surface backbox. If the BG-12LX is being semi-flush mounted, then the optional trim ring (BG12TR) may be used. The BG12TR is



FL PullStation.jpg

usually needed for semi-flush mounting with 4" (10.16 cm) or double-gang boxes (not with single-gang boxes).

Operation

Pushing in, then pulling down on the handle causes it to latch in the down/activated position. Once latched, the word "ACTIVATED" (in bright yellow) appears at the top of the handle, while a portion of the handle protrudes from the bottom of the station. To reset the station, simply unlock the station with the key and pull the door open. This action resets the handle; closing the door automatically resets the switch.

Each manual station, on command from the control panel, sends data to the panel representing the state of the manual switch. Two rotary decimal switches allow address settings (1 – 159 with Breakaway Tab removed for MS-9600 Series, 1 – 99 and MS-9200UDLS, 1 – 50 for MS-9050UD).

Architectural/Engineering Specifications

Manual Fire Alarm Stations shall be non-coded, with a key-operated reset lock in order that they may be tested, and so designed that after actual Emergency Operation, they cannot be restored to normal except by use of a key. An operated station shall automatically condition itself so as to be visually detected as activated. Manual stations shall be constructed of red-colored polycarbonate material with clearly visible operating instructions provided on the cover. The word FIRE shall appear on the front of the stations in white letters, 1.00 inches (2.54 cm) or larger. Stations shall be suitable for surface mounting on matching backbox SB-10 or SB-I/O; or semi-flush mounting on a standard single-gang, double-gang, or 4" (10.16 cm) square electrical box, and shall be installed

within the limits defined by the Americans with Disabilities Act (ADA) or per national/local requirements. Manual Stations shall be Underwriters Laboratories listed.

Manual stations shall connect with two wires to one of the control panel SLC loops. The manual station shall, on command from the control panel, send data to the panel representing the state of the manual switch. Manual stations shall provide address setting by use of rotary decimal switches.

Product Line Information

BG-12LX: Dual-action addressable pull station. Includes key locking feature. (Listed for Canadian and non-Canadian applications.)

SB-10: Surface backbox; metal.

SB-I/O: Surface backbox; plastic.

BG12TR: Optional trim ring.

17003: Keys, set of two.

Agency Listings and Approvals

In some cases, certain modules or applications may not be listed by certain approval agencies, or listing may be in process. Consult factory for latest listing status.

- **UL/ULC Listed:** S711 (listed for Canadian and non-Canadian applications).
- **MEA:** 67-02-E.
- **CSFM:** 7150-0075:0184.
- **FM Approved.**

Patented: U.S. Patent No. D428,351; 6,380,846; 6,314,772; 6,632,108.

FireLite® Alarms® is a registered trademark of Honeywell International Inc. ©2012 by Honeywell International Inc. All rights reserved. Unauthorized use of this document is strictly prohibited.



This document is not intended to be used for installation purposes.
We try to keep our product information up-to-date and accurate.
We cannot cover all specific applications or anticipate all requirements.
All specifications are subject to change without notice.



Made in the U.S. A.

For more information, contact Fire•Lite Alarms. Phone: (800) 627-3473, FAX: (877) 699-4105.
www.firelite.com

SD365 Series

Addressable Photoelectric Smoke Detectors



Addressable Devices

The Fire•Lite® Alarms SD365(A), SD365R(A), and SD365HT(A) intelligent plug-in smoke detectors are designed for both performance and aesthetics, and are direct replacements for the SD355 Series. A new modern, sleek, contemporary design and enhanced optical sensing chamber is engineered to sense smoke produced by a wide range of combustion sources in accordance with more stringent code standards.

Exclusively for use with Fire•Lite's addressable fire alarm control panels, the SD365(A) Series point ID capability allows each detector's address to be set with rotary, decimal address switches, providing exact detector location for emergency personnel to quickly locate a fire during its early stages, potentially saving precious rescue time while also reducing property damage. Two LEDs on each sensor light to provide a local, visible sensor indication.

The SD365(A) Series also offers 135°F (57°C) fixed temperature thermal sensing on the SD365T(A) and a remote test capable detector on the SD365R(A) for use with DNR(A)/DNRW duct smoke detector housings.

Features

SLC LOOP:

- Two-wire SLC loop connection
- Unit uses base for wiring
- Compatible with LiteSpeed™ and CLIP protocol systems
- Stable communication technique with noise immunity

ADDRESSING:

- Addressable by device
- Rotary, decimal addressing
(Refer to the *Fire•Lite panel manuals* for device capacity.)

ARCHITECTURE:

- Sleek, low-profile, stylish design
- Unique single-source design to respond quickly and dependably to a broad range of fires
- Integral communications and built-in device-type identification
- Built-in tamper resistant feature
- Remote test feature from the panel
- Walk test with address display (an address on 121 will blink the detector LED: 12-[pause]-1 (*LiteSpeed systems only*))
- Built-in functional test switch activated by external magnet
- Removable cover and insect-resistant screen for simple field cleaning
- Expanded color options

OPERATION:

- Designed to meet UL 268 7th Edition
- Factory preset at 1.5% nominal sensitivity for panel alarm threshold level
- LED "blinks" when the unit is polled (communicating with the fire panel) and latches in alarm.
- Low standby current

MECHANICALS:

- Sealed against back pressure
- SEMS screws for wiring of the separate base
- Designed for direct-surface or electrical-box mounting



- Plugs into separate base for ease of installation and maintenance
- Separate base allows interchange of photoelectric, ionization and thermal sensors

OPTIONS:

- Optional relay, isolator, and sounder bases

Installation

SD365 Series plug-in intelligent smoke detectors use a detachable base to simplify installation, service and maintenance. Installation instructions are shipped with each detector.

Mount detector base (all base types) on an electrical backbox which is at least 1.5" (3.81 cm) deep. For a chart of compatible junction boxes, see *DF-60059*.

NOTE: Because of the inherent supervision provided by the SLC loop, end-of-line resistors are not required. Wiring "T-taps" or branches are permitted for Class "B" wiring only.

When using relay or sounder bases, consult the *I300(A) installation sheet I56-3626* for device limitations between isolator modules and isolator bases.

Construction

These detectors are constructed of fire-resistant plastic. The SD365 Series plug-in intelligent smoke detectors are designed to commercial standards and offer an attractive appearance.

Operation

Each SD365 Series detector uses one of the panel's addresses (total limit is panel dependent) on the Fire•Lite Signaling Line Circuit (SLC). It responds to regular polls from the control panel and reports its type and the status. If it receives a test command from the panel (or a local magnet test), it stimulates its electronics and reports an alarm. It blinks its LEDs when polled and turns the LEDs on when commanded by the panel. The SD365 Series offers features and performance that represent the latest in smoke detector technology.

Detector Sensitivity Test

Each detector can have its sensitivity tested (required per NFPA 72, Chapter 14 on *Inspection, Testing and Maintenance*) when installed/connected to an Fire•Lite addressable fire alarm control panel. The results of the sensitivity test can be printed for record keeping.

Product Line Information

NOTE: “-IV” suffix indicates CLIP and LiteSpeed device.

NOTE: “A” suffix indicates Canadian version.

SD365: White, low-profile intelligent photoelectric sensor, LiteSpeed only

SD365A: Same as SD365 but with ULC listing

SD365-IV: Ivory, low-profile intelligent photoelectric sensor

SD365A-IV: Same as SD365-IV but with ULC listing

SD365T: White, same as **SD365** but includes a built-in 135°F (57°C) fixed-temperature thermal device, LiteSpeed only

SD365TA: Same as SD365T but with ULC listing

SD365T-IV: Ivory, same as SD365T but includes a built-in 135°F (57°C) fixed-temperature thermal device

SD365TA-IV: Same as SD365T-IV but with ULC listing

SD365R: White, low-profile intelligent photoelectric sensor, remote test capable, for use with DNR/DNRW, LiteSpeed only

SD365RA: Same as SD365R but with ULC listing, for use with DNRA

SD365R-IV: Ivory, low-profile intelligent photoelectric sensor, remote test capable, for use with DNR/DNRW

SD365RA-IV: Same as SD365R-IV but with ULC listing, for use with DNRA

INTELLIGENT BASES

NOTE: For details on intelligent bases, see DF-60059.

B300-6: White, 6” base, standard flanged low-profile mounting base (CSFM: 7300-1653:0109)

B300-6-IV: Ivory, 6” base, standard flanged low-profile mounting base (CSFM: 7300-1653:0109)

B300A-6: Same as B300-6, ULC listed

B300A-6-IV: Ivory, 6” standard flanged low-profile mounting base, ULC listed

B300-6-BP: Bulk pack of B300-6, package contains 10

B501-WHITE: White, 4” standard European flangeless mounting base. UL/ULC listed (CSFM: 7300-1653:0109)

B501-BL: Black, 4” standard European flangeless mounting base. UL/ULC listed (CSFM: 7300-1653:0109)

B501-IV: Ivory color, 4” standard European flangeless mounting base. UL/ULC listed (CSFM: 7300-1653:0109)

B501-WHITE-BP: Bulk pack of B501-WHITE contains 10

B224RB-WH: White, relay base (CSFM: 7300-1653:0216)

B224RB-IV: Ivory, relay base (CSFM: 7300-1653:0216)

B224RBA-WH: White, relay base, ULC listing

B224RBA-IV: Ivory, relay base, ULC listing

B224BI-WH: White, isolator detector base (CSFM: 7300-1653:0216)

B224BI-IV: Ivory isolator detector base (CSFM: 7300-1653:0216)

B224BIA-WH: White, isolator detector base, ULC listing

B224BIA-IV: Ivory isolator detector base, ULC listing

B200S-WH: White, Intelligent addressable sounder base capable of producing sound output in high or low volume with ANSI Temporal 3, ANSI Temporal 4, continuous tone, marching tone, and custom tone. Uses LiteSpeed protocol. (CSFM: 7300-1653:0213)

B200S-IV: Ivory, Intelligent addressable sounder base capable of producing sound output in high or low volume with ANSI Temporal 3, ANSI Temporal 4, continuous tone, marching tone, and custom tone. Uses LiteSpeed protocol. (CSFM: 7300-1653:0213)

B200SA-WH: Same as B200S-WH, ULC listing

B200SA-IV: Same as B200S-IV, ULC listing

B200SCOA-WH: White, Intelligent, programmable sounder base in English/French (required in Canada for ULC applications with CO Series detector applications)

B200SCOA-IV: Ivory Intelligent, programmable sounder base in English/French (required in Canada for ULC applications with CO Series detector applications, ULC listing)

B200S-LF-WH: White, Low Frequency Intelligent, programmable sounder base. Produces a fundamental frequency of 520 Hz +/- 10% with a square wave or its equivalent; designed to meet the NFPA 72 sleeping space requirement. (CSFM: 7300-1653:0238)

B200S-LF-IV: Ivory, Low Frequency Intelligent, programmable sounder base. Produces a fundamental frequency of 520 Hz +/- 10% with a square wave or its equivalent; designed to meet the NFPA 72 sleeping space requirement. (CSFM: 7300-1653:0238)

B200SR-WH: White, Intelligent sounder base capable of producing sound output with ANSI Temporal 3 or continuous tone. Intended for retrofit applications. (CSFM: 7300-1653:0213)

B200SR-IV: Ivory, Intelligent sounder base capable of producing sound output with ANSI Temporal 3 or continuous tone. Intended for retrofit applications. (CSFM: 7300-1653:0213)

B200SRA-WH: Same as B200SR-WH with, ULC listing

B200SRA-IV: Same as B200SR-IV in Ivory color, ULC listing

B200SR-LF-WH: White, Low Frequency Intelligent, programmable sounder base. Produces a fundamental frequency of 520 Hz +/- 10% with a square wave or its equivalent; designed to meet the NFPA 72 sleeping space requirement. Intended for retrofit applications. (CSFM: 7300-1653:0238)

B200SR-LF-IV: Ivory, Low Frequency Intelligent, programmable sounder base. Produces a fundamental frequency of 520 Hz +/- 10% with a square wave or its equivalent; designed to meet the NFPA 72 sleeping space requirement. Intended for retrofit applications. (CSFM: 7300-1653:0238)

MOUNTING KITS AND ACCESSORIES

TR300: White, replacement flange for B210LP(A) base

TR300-IV: Ivory, replacement flange for B210LP(A) base

RA100Z(A): Remote LED annunciator. 3-32 VDC. Mounts to a U.S. single-gang electrical box. For use with B501(A) and B300-6(A).

M02-04-00: Test magnet

M02-09-00: Test magnet with telescoping handle

CK300: Color Kit (includes cover and trim ring), white, 10-pack

CK300-IV: Color Kit (includes cover and trim ring), ivory, 10-pack

CK300-BL: Color Kit (includes cover and trim ring), black, 10-pack

SYSTEM SPECIFICATIONS

Sensitivity:

- UL Applications: 0.5% to 4.0% per foot obscuration.
- ULC Applications: 0.5% to 3.5% per foot obscuration

Size: 2.0" (51mm) high; base determines diameter

- **B300-6:** 6.1" (15.6 cm) diameter
- **B501:** 4" (10.2 cm) diameter

For a complete list of detector bases see DF-60983

Shipping weight: 3.4 oz. (95 g)

Operating temperature range:

- SD365: 32°F to 122°F (0°C to 50°C)
- SD365T Series: 32°F to 100°F (0°C to 38°C)
- SD365R Series installed in a DNR/DNRW, -4°F to 158°F (-20°C to 70°C)

UL/ULC Listed Velocity Range: 0-4000 ft/min. (1219.2 m/min.), suitable for installation in ducts

Relative humidity: 10% – 93% non-condensing

Thermal ratings: fixed-temperature set point 135°F (57°C), rate-of-rise detection 15°F (8.3°C) per minute, high temperature heat 190°F (88°C)

ELECTRICAL SPECIFICATIONS

Voltage range: 15 - 32 volts DC peak

Standby current (max. avg.): 200µA @ 24 VDC (one communication every 5 seconds with LED enabled)

Max current: 4.5 mA @ 24 VDC ("ON")

DETECTOR SPACING AND APPLICATIONS

Fire•Lite recommends spacing detectors in compliance with NFPA 72. In low airflow applications with smooth ceiling, space detectors 30 feet (9.1m). For specific information regarding detector spacing, placement, and special applications refer to NFPA 72. A *System Smoke Detector Application Guide*, document SPAG91, is available at www.systemsensor.com.

Listings and Approvals

Listings and approvals below apply to the SD365 Series detectors. In some cases, certain modules may not be listed by certain approval agencies, or listing may be in process. Consult factory for latest listing status.

- UL/ULC Listing: S1059
- FM Approved
- CSFM: 7272-0075:0502

LiteSpeed™ is a trademark, and Fire•Lite® Alarms and System Sensor® are registered trademarks of Honeywell International Inc.
©2020 by Honeywell International Inc. All rights reserved. Unauthorized use of this document is strictly prohibited.



This document is not intended to be used for installation purposes.
We try to keep our product information up-to-date and accurate.
We cannot cover all specific applications or anticipate all requirements.
All specifications are subject to change without notice.

For more information, contact Fire•Lite Alarms. Phone: (800) 627-3473, FAX:(877) 699-4105.
www.firelite.com

Country of Origin: Mexico

D355PL(A)/DNRW InnovairFlex

Intelligent Non-Relay Photoelectric Duct Smoke Detector



Intelligent Addressable Devices

General

The Fire•Lite InnovairFlex® D355PL(A) intelligent non-relay photoelectric duct smoke detector and DNRW watertight non-relay photoelectric duct smoke detector feature a pivoting housing that fits both square and rectangular footprints capable of mounting to a round or rectangular duct.

DNRW duct smoke detector, with its NEMA-4 rating, is listed as a watertight, UV resistant enclosure providing protection against falling dirt, rain, and windblown dust, splashing and hose directed water, allowing operators to use the detector in the most extreme environments.

These units sense smoke in the most challenging conditions, operating in airflow speeds of 100 to 4,000 feet per minute (0.5 to 20.32 m/s), temperatures of -4°F to 158°F (-20°C to 70°C), and a humidity range of 0 to 95 percent (non-condensing.)

An improved cover design isolates the sensor head, which allows for ease of maintenance. A cover tamper feature indicates a trouble signal for a removed or improperly installed sensor cover. The Fire•Lite InnovairFlex housing provides a 3/4-inch conduit knockout and ample space to facilitate easy wiring and mounting of a relay module.

The Fire•Lite InnovairFlex duct smoke detector can be customized to meet local codes and specifications without additional wiring. The new InnovairFlex product line is compatible with all previous Innovair models, including remote test accessories.

Features

- Photoelectric, integrated low-flow technology.
- Air velocity rating from 100 ft/min to 4,000 ft/min (0.5 m/s to 20.32 m/s).
- Versatile mounting options: square or rectangular configuration.
- Broad ranges for operating temperature (-4°F to 158°F, -20°C to 70°C) and humidity (0% to 95% non-condensing).
- Patented sampling tube installs from front or back of the detector with no tools required.
- Cover tamper signal.
- Increased wiring space with a newly added 3/4" conduit knockout.
- Available space within housing to accommodate mounting of a relay module.
- Easily accessible code wheels on sensor head (sold separately).
- Clear cover for convenient visual inspection.
- Remote testing capability.
- Requires com line power only.
- Accommodates the installation of an addressable relay module, sold separately, (CRF-300) for applications requiring a Form-C relay.



Specifications

Size: (Rectangle) 14.38 in (37 cm) Length; 5 in (12.7 cm) Width, 2.5 in (6.6 cm) Depth.

Size: (Square) 7.75 in (19.7 cm) Length; 9 in (22.9 cm) Width; 2.5 in (6.35 cm) Depth.

Weight: 1.6 lb (0.73 kg).

Operating Temperature Range: -4°F to 158°F (-20°C to 70°C).

Storage Temperature Range: -22°F to 158°F (-30°C to 70°C).

Operating Humidity Range: 0% to 95% relative humidity (non-condensing).

Air Duct Velocity: 100 to 4,000 ft/min (0.5 to 20.32 m/s).

Accessories

Fire•Lite provides system flexibility with a variety of accessories, including two remote test stations and different means of visible and audible system annunciation. As with our duct smoke detectors, all duct smoke detectors accessories are UL listed.

D355PLs and DNRWs with a date code of 0013 or higher do not require external 24VDC for remote test applications when used with a remote-test-capable detector.

ACCESSORY CURRENT LOADS AT 24 VDC

Device	Standby	Alarm
RA100Z	0mA	12 mA Max
RTS151/ RTS151KEY	0mA	12mA Max

Agency Listings and Approvals

Consult product manual for lists of compatible UL-Listed devices. In some cases, certain modules may not be listed by certain approval agencies, or listing may be in process. Consult factory for latest listing status.

- **UL:** S1059.
- **ULC:** S1059

- **CSFM:** 3242-1653:0209.
- **FM approved.**

Product Line Information

D355PL: Intelligent non-relay photoelectric low flow smoke detector housing. Includes SD355R Detector.

DNRW: Watertight intelligent non-relay photoelectric low flow duct smoke detector housing. Does not include detector head.

SD355R(A): Remote test capable addressable low-profile photoelectric smoke detector.

SD355(A): Addressable low-profile photoelectric smoke detector.

DCOIL: Remote test coil. Required for older DNR(W) duct detector housing.

DST1: Metal sampling tube duct width up to 1 ft (0.3m).

DST1.5: Metal sampling tube duct widths up to 1 ft to 2 ft (0.3 to 0.6 m).

DST3: Metal sampling tube duct widths up to 2 ft to 4 ft (0.6 to 1.2 m).

DST5: Metal sampling tube duct widths up to 4 ft to 8 ft (1.2 to 2.4 m).

DST10: Metal sampling tube duct widths up to 8 ft to 12 ft (2.4 to 3.7 m).

DH400OE-1: Weatherproof enclosure.

ETX: Metal exhaust tube duct, width 1 ft (0.3 m).

M02-04-00: Test magnet.

P48-21-00: End cap for metal sampling tubes.

RA100Z: Remote annunciator alarm LED.

RTS151: Remote test station.

RTS151KEY: Remote test station with key lock.

Important Note

- DNRW duct detector housings with a date code of 0013 or higher do not require a DCOIL or auxiliary 24 VDC for remote test applications when used with a remote test capable detector.
- DNRW duct detector housings with a date code of 0012 or earlier require a DCOIL and auxiliary 24 VDC power for remote test applications.

Fire•Lite® Alarms is a registered trademark of Honeywell International Inc.
©2012 by Honeywell International Inc. All rights reserved. Unauthorized use
of this document is strictly prohibited.



This document is not intended to be used for installation purposes.
We try to keep our product information up-to-date and accurate.
We cannot cover all specific applications or anticipate all requirements.
All specifications are subject to change without notice.



Made in the U.S. A.

For more information, contact Fire•Lite Alarms. Phone: (800) 627-3473, FAX: (877) 699-4105.
www.firelite.com

Duct Smoke Detector Accessories



Miscellaneous

General

Duct smoke detector accessories add functionality to the duct smoke system by allowing quick, convenient inspections at eye level and effective audible and visual notification options. All System Sensor duct smoke detectors and accessories are UL listed.

Specifications

APA151 PIEZO ANNUNCIATOR

The **APA151** piezo annunciator, which replaces the APA451 with a new, improved look, provides an audible alarm signal, a red LED to indicate alarm status, and a green LED to indicate power status. It is intended for use with System Sensor 4-wire conventional duct smoke detector applications without a system control panel, to comply with NFPA 90A.



APA151.wmf

APA151 Piezo Annunciator	
Voltage	Regulated 24 VDC
Operating Voltage	16 to 33 VDC
Maximum Alarm Current	30 mA
Temperature Range	32°F to 120°F (0°C to 49°C)
Relative Humidity	10 to 93%, non-condensing
Wire Gauge	12 to 18 AWG
Dimensions	4.6" H x 2.9" W x .45" D

MHR/MHW MINI-HORNS

The **MHR** and **MHW** SpectrAlert® Advance mini-horns feature temporal or continuous tones at high and low volume settings. Their small footprint allows mounting to single-gang back boxes for applications where a small device is desired.



MHR.wmf, MHW.wmf



60535cov.wmf

MHR/MHW SpectrAlert Advance Mini-Horns	
Voltage	Regulated 12 DC or FWR (Full Wave Rectified) or Regulated 24 VDC or FWR
Operating Voltage	8 to 33 VDC (9 to 33 VDC with Sync-Circuit™ Module)
Sounder Current Draw	22 mA RMS max. at 8 to 17.5 Volts DC 17 mA RMS max. at 8 to 17.5 Volts FWR 29 mA RMS max. at 16 to 33 Volts DC 25 mA RMS max. at 16 to 33 Volts FWR
Temperature Range	32°F to 120°F (0°C to 49°C)
Humidity Range	10 to 93% non-condensing
Nominal Sounder Frequency	3 kHz
Wire Gauge	12 to 18 AWG
Dimensions	4.6"H x 2.9"W x 0.45"D

RA100Z/RA100ZA REMOTE ANNUNCIATORS

The **RA100Z** and **RA100ZA** remote annunciators are designed for both conventional and intelligent applications. Their red LED provides visual indication of an alarm condition.



RA100Z.wmf

RA100Z/RA100ZA Remote Annunciator	
Voltage Range	Conventional System: 3.1 to 32 VDC Intelligent System: 18 to 32 VDC
Maximum Alarm Current	10 mA
Dimensions	4.6"H x 2.8"W x 1.3"D

RTS151/RTS151KEY REMOTE TEST STATIONS

The **RTS151** and **RTS151KEY** remote test stations are automatic fire detector accessories designed to test duct smoke detectors from a convenient location. For 4-wire detectors, the **RTS151KEY** test station features a multi-colored LED that alternates between steady green and red. For 2-wire detectors, the LED illuminates red for alarm.



RTS151.wmf, RTS151KEY.wmf

RTS151 Remote Test Station	
Power Requirements	Alarm LED 2.8 to 32 VDC, 10 mA max. Total Current: 95 mA max.
Test Switch	10 VA @ 32 VDC
Reset Switch	10 VA @ 32 VDC
Alarm Response Time	40 seconds max.
Temperature Range	14°F to 140°F (-10°C to 60°C)
Relative Humidity	95% non-condensing
Wire Gauge	14 to 18 AWG
Dimensions	4.8"H x 2.9W x 1.4"D

RTS151KEY Remote Test Station with Key

Power Requirements	Power LED (Green): 14 to 35 VDC, 12 mA max. Alarm LED (RED): 2.8 to 32 VDC, 12 mA max.
Alarm Response Time	40 seconds max.
Temperature Range	14°F to 140°F (-10°C to 60°C)
Relative Humidity	95% non-condensing
Wire Gauge	14 to 18 AWG
Dimensions	4.6"H x 2.75W x 1.8"D

RTS2/RTS-AOS MULTI-SIGNALLING ACCESSORIES

The **RTS2** and **RTS2-AOS** multi-signaling accessories are designed to work with InnovairFlex 4-wire conventional duct smoke detectors. These accessories include a key switch that can be used to select one of two connected sensors to be tested, reset, or both by a push button switch. They also enable sensitivity measurements using the SENS-RDR sensitivity reader (sold separately). The **AOS** (Add-On Strobe) is an optional accessory included with the **RTS2-AOS** model.



RTS-AOS.wmf, AOS.wmf

RTS2 and RTS-AOS Multi-Signaling Accessory

Voltage	20 to 29 VDC
Power Requirements	Standby: 3.0 mA max. Trouble: 16.0 mA max. Alarm without Strobe: 30 mA max. Alarm with Strobe: 55 mA max.
Sounder	85 dBA at 10 ft.
Temperature Range	14°F to 140°F (-10°C to 60°C)
Relative Humidity	95% non-condensing
Wire Gauge	14 to 22 AWG
Dimensions	4.8"W x 5.3"H x 1.6"D

Product Line Information

APA151: Piezo Annunciator

MHR: Mini-Horn, Red

MHW: Mini-Horn, White

RA100Z/RA100ZA: Remote Annunciator

RTS151: Remote Test Station

RTS151KEY: Remote Test Station with Key

RTS2: Multi-signaling Accessory

AOS: Add-On Strobe

RTS2-AOS: Multi-Signaling Accessory

Temperature and Humidity Ranges

This system meets NFPA requirements for operation at 0 – 49°C/32 – 120°F and at a relative humidity 93% ± 2% RH (noncondensing) at 32°C ± 2°C (90°F ± 3°F). However, the useful life of the system's standby batteries and the electronic components may be adversely affected by extreme temperature ranges and humidity. Therefore, it is recommended that this system and its peripherals be installed in an environment with a normal room temperature of 15 – 27°C/60 – 80°F.

Agency Listings and Approvals

The listings and approvals below apply to the basic products. In some cases, certain modules may not be listed by certain approval agencies, or listing may be in process. Consult factory for latest listing status.

- **UL: S4011 (APA 151, MHR, MHW), S2522 (RTS2, RA100Z, RTS151, RTS151KEY, RTS2-AOS)**
- **FM Approved**
- **CSFM: 7135-1653:0212**

Fire•Lite® Alarms and **System Sensor®** are registered trademarks of Honeywell International Inc.
©2012 by Honeywell International Inc. All rights reserved. Unauthorized use of this document is strictly prohibited.



This document is not intended to be used for installation purposes.
We try to keep our product information up-to-date and accurate.
We cannot cover all specific applications or anticipate all requirements.
All specifications are subject to change without notice.



For more information, contact Fire•Lite Alarms. Phone: (800) 627-3473, FAX: (877) 699-4105.
www.firelite.com

CRF-300(A)

Relay Module



Addressable Devices

General

The **CRF-300(A)** Addressable Relay Module provides the system with a dry-contact output for activating a variety of auxiliary devices, such as fans, door holders, dampers, control equipment, etc. Addressability allows the dry contact to be activated through panel programming, on a select basis.

LiteSpeed™ is a communication protocol developed by Fire•Lite Engineering that greatly enhances the speed of communication between analog intelligent devices. Intelligent devices communicate in a grouped fashion. If one of the devices within the group has new information, the panel CPU stops the group poll and concentrates on single points. The net effect is response speed greater than five times that of other designs.

Features

- Built-in type identification automatically identifies these devices to the control panel.
- Internal circuitry and relay powered directly by two-wire SLC loop.
- Integral LED “blinks” green each time a communication is received from the control panel and turns on in steady red when activated.
- High noise immunity (EMF/RFI).
- Wide viewing angle of LED.
- SEMS screws with clamping plates for wiring ease.
- Direct-dial entry of address: 01– 159 for MS-9600(A) series panels, 01 – 99 on MS-9200UDLS(A) and MS-9050UD(A).

Applications

The CRF-300(A) may be programmed to operate dry contacts for door holders, Air Handling Unit shutdown, etc., and to reset four-wire smoke detector power.

Construction

- The face plate is made of off-white heat-resistant plastic.
- Controls include two rotary switches for direct-dial entry of address setting.
- The CRF-300(A) is configured for a single Class B (Style Y) or Class A (Style Z) Notification Appliance Circuit.
- The CRF-300(A) provides two Form-C dry contacts that switch together.

Operation

Each CRF-300(A) uses one of the addresses on a SLC loop. It responds to regular polls from the control panel and reports its type and status, including the open/normal/short status of its Notification Appliance Circuit (NAC). The LED blinks with each poll received. On command, it activates its internal relay.

NOTE: Open/short supervision is suspended with the CRF-300.

Rotary switches set a unique address for each module. The address may be set before or after mounting. The built-in TYPE CODE (not settable) will identify the module to the control panel, so as to differentiate between a control module and a relay module.



CRF-300(A)

Specifications

Normal operating voltage: 15 to 32 VDC.

Maximum SLC current draw: 6.5 mA (LED on).

Average operating current: 230 μ A direct poll (CLIP mode), 255 μ A group poll (LiteSpeed mode) with LED flashing.

EOL resistance: not used.

Temperature range: 32°F to 120°F (0°C to 49°C).

Humidity range: 10% to 93% non-condensing.

Dimensions: 4.5" (11.43 cm) high x 4" (10.16 cm) wide x 1.25" (3.175 cm) deep. Mounts to a 4" (10.16 cm) square x 2.125" (5.398 mm) deep box.

Relay Contact Ratings

Load Description	Application	Maximum Voltage	Current Rating
Resistive	Non-Coded	30 VDC	3.0 A
Resistive	Coded	30 VDC	2.0 A
Resistive	Non-Coded	110 VDC	0.9 A
Resistive	Non-Coded	125 VAC	0.9 A
Inductive (L/R=5ms)	Coded	30 VDC	0.5 A
Inductive (L/R=2ms)	Coded	30 VDC	1.0 A
Inductive (PF=0.35)	Non-Coded	125 VAC	0.5 A

Agency Listings and Approvals

In some cases, certain modules may not be listed by certain approval agencies, or listing may be in process. Consult factory for latest listing status.

- **UL:** S2424
- **ULC:** S2424
- **FM approved**
- **CSFM:** 7300-0075:185
- **MEA:** 72-01-E

Product Line Information

CRF-300(A): Intelligent addressable relay module.

: Intelligent addressable relay module, ULC listed model.

SMB500: Optional surface-mount backbox.

NOTE: For installation instructions, see document 156-1190-005 and refer to the SLC Wiring Manual, document 51309.

LiteSpeed™ is a trademark and **Fire•Lite®** Alarms is a registered trademark of Honeywell International Inc.
©2009 by Honeywell International Inc. All rights reserved. Unauthorized use of this document is strictly prohibited.



This document is not intended to be used for installation purposes.
We try to keep our product information up-to-date and accurate.
We cannot cover all specific applications or anticipate all requirements.
All specifications are subject to change without notice.



Made in the U.S. A.

For more information, contact Fire•Lite Alarms. Phone: (800) 627-3473, FAX: (877) 699-4105.
www.firelite.com

MMF-300(A) Series, MDF-300(A)

Addressable Monitor Modules



Addressable Devices

General

Four different monitor modules are available for Fire•Lite's intelligent control panels to suit a variety of applications. Monitor modules are used to supervise a circuit of dry-contact input devices, such as conventional heat detectors and pull stations, or monitor and power a circuit of two-wire smoke detectors (MMF-302(A)).

MMF-300(A) is a standard-sized module (typically mounts to a 4" [10.16 cm] square box) that supervises either a Style D (Class A) or Style B (Class B) circuit of dry-contact input devices.

MMF-301(A) is a miniature monitor module a mere 1.3" (3.302 cm) H x 2.75" (6.985 cm) W x 0.5" (1.270 cm) D used to supervise a Style B (Class B) circuit of dry-contact input devices. Its compact design allows the MMF-301(A) to be mounted in a single-gang box behind the device it monitors.

MMF-302(A) is a standard-sized module used to monitor and supervise compatible two-wire, 24 volt, smoke detectors on a Style D (Class A) or Style B (Class B) circuit.

MDF-300(A) is a standard-sized dual monitor module used to monitor and supervise two independent two-wire Style B (Class B) dry-contact initiating device circuits (IDCs) at two separate, consecutive addresses in intelligent, two-wire systems.

LiteSpeed™ is a communication protocol developed by Fire•Lite Engineering that greatly enhances the speed of communication between analog intelligent devices. Intelligent devices communicate in a grouped fashion. If one of the devices within the group has new information, the panel CPU stops the group poll and concentrates on single points. The net effect is response speed greater than five times that of other designs.

MMF-300(A) Monitor Module

- Built-in type identification automatically identifies this device as a monitor module to the control panel.
- Powered directly by two-wire SLC loop. No additional power required.
- High noise (EMF/RFI) immunity.
- SEMS screws with clamping plates for ease of wiring.
- Direct-dial entry of address: 01 – 159 on MS-9600 series panels, 01 – 99 on other compatible systems.
- LED flashes during normal operation and latches on steady to indicate alarm.

The MMF-300(A) Monitor Module is intended for use in intelligent, two-wire systems, where the individual address of each module is selected using the built-in rotary switches. It provides either a two-wire or four-wire fault-tolerant Initiating Device Circuit (IDC) for normally-open-contact fire alarm and supervisory devices. The module has a panel-controlled LED indicator. The MMF-300(A) can be used to replace M300(A) modules in existing systems.

MMF-300(A) APPLICATIONS

Use to monitor a zone of four-wire smoke detectors, manual fire alarm pull stations, waterflow devices, or other normally-open dry-contact alarm activation devices. May also be used to monitor normally-open supervisory devices with special supervisory indication at the control panel. Monitored circuit



MMF-300(A) (Type H)

may be wired as an NFPA Style B (Class B) or Style D (Class A) Initiating Device Circuit. A 47K ohm End-of-Line Resistor (provided) terminates the Style B circuit. No resistor is required for supervision of the Style D circuit.

MMF-300(A) OPERATION

Each MMF-300(A) uses one of the available module addresses on an SLC loop. It responds to regular polls from the control panel and reports its type and the status (open/normal/short) of its Initiating Device Circuit (IDC). A flashing LED indicates that the module is in communication with the control panel. The LED latches steady on alarm (subject to current limitations on the loop).

MMF-300(A) SPECIFICATIONS

Nominal operating voltage: 15 to 32 VDC.

Maximum current draw: 5.0 mA (LED on).

Average operating current: 350 µA (LED flashing), 1 communication every 5 seconds, 47k EOL.

Maximum IDC wiring resistance: 40 ohms.

EOL resistance: 47K ohms.

Temperature range: 32°F to 120°F (0°C to 49°C).

Humidity range: 10% to 93% noncondensing.

Dimensions: 4.5" (11.43 cm) high x 4" (10.16 cm) wide x 1.25" (3.175 cm) deep. Mounts to a 4" (10.16 cm) square x 2.125" (5.398 cm) deep box.

MMF-301(A) Mini Monitor Module

- Built-in type identification automatically identifies this device as a monitor module to the panel.
- Powered directly by two-wire SLC loop. No additional power required.
- High noise (EMF/RFI) immunity.
- Tinned, stripped leads for ease of wiring.
- Direct-dial entry of address: 01 – 159 on MS-9600 series panels, 01 – 99 on other compatible systems

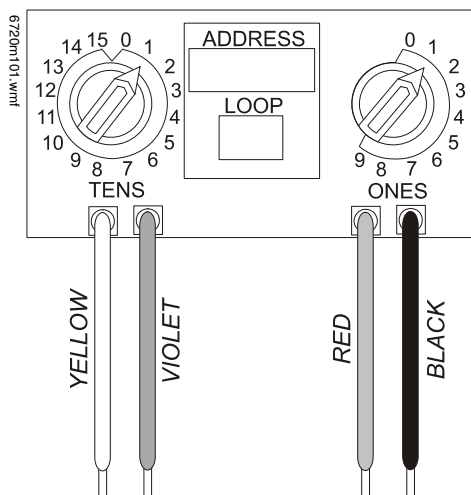

The MMF-301(A) Mini Monitor Module can be installed in a single-gang junction directly behind the monitored unit. Its small size and light weight allow it to be installed without rigid mounting. The MMF-301(A) is intended for use in intelligent, two-wire systems where the individual address of each module is selected using rotary switches. It provides a two-wire initiating device circuit for normally-open-contact fire alarm devices. The MMF-301(A) can be used to replace M301(A) modules in existing systems.

MMF-301(A) APPLICATIONS

Use to monitor a single device or a zone of four-wire smoke detectors, manual fire alarm pull stations, waterflow devices, or other normally-open dry-contact devices. May also be used to monitor normally-open supervisory devices with special supervisory indication at the control panel. Monitored circuit/device is wired as an NFPA Style B (Class B) Initiating Device Circuit. A 47K ohm End-of-Line Resistor (provided) terminates the circuit.

MMF-301(A) OPERATION

Each MMF-301(A) uses one of the available module addresses on an SLC loop. It responds to regular polls from the control panel and reports its type and the status (open/normal/short) of its Initiating Device Circuit (IDC).

MMF-301(A) SPECIFICATIONS

Nominal operating voltage: 15 to 32 VDC.

Average operating current: 350 μ A, 1 communication every 5 seconds, 47k EOL; 600 μ A Max. (Communicating, IDC Shorted).

Maximum IDC wiring resistance: 40 ohms.

Maximum IDC Voltage: 11 Volts.

Maximum IDC Current: 400 μ A.

EOL resistance: 47K ohms.

Temperature range: 32°F to 120°F (0°C to 49°C).

Humidity range: 10% to 93% noncondensing.

Dimensions: 1.3" (3.302 cm) high x 2.75" (6.985 cm) wide x 0.65" (1.651 cm) deep.

Wire length: 6" (15.24 cm) minimum.

MMF-302(A) Interface Module

- Supports compatible two-wire smoke detectors.
- Supervises IDC wiring and connection of external power source.
- High noise (EMF/RFI) immunity.
- SEMS screws with clamping plates for ease of wiring.
- Direct-dial entry of address: 01 – 159 on MS-9600 series panels, 01 – 99 on other compatible systems.
- LED flashes during normal operation.
- LED latches steady to indicate alarm on command from control panel.

The MMF-302(A) Interface Module is intended for use in intelligent, addressable systems, where the individual address of each module is selected using built-in rotary switches. This module allows intelligent panels to interface and monitor two-wire conventional smoke detectors. It transmits the status (normal, open, or alarm) of one full zone of conventional detectors back to the control panel. All two-wire detectors being monitored must be UL compatible with the module. The MMF-302(A) can be used to replace M302(A) modules in existing systems.

MMF-302 (A) APPLICATIONS

Use the MMF-302(A) to monitor a zone of two-wire smoke detectors. The monitored circuit may be wired as an NFPA Style B (Class B) or Style D (Class A) Initiating Device Circuit. A 3.9 K ohm End-of-Line Resistor (provided) terminates the end of the Style B or D (class B or A) circuit (maximum IDC loop resistance is 25 ohms). Install ELR across terminals 8 and 9 for Style D application.

MMF-302(A) OPERATION

Each MMF-302(A) uses one of the available module addresses on an SLC loop. It responds to regular polls from the control panel and reports its type and the status (open/normal/short) of its Initiating Device Circuit (IDC). A flashing LED indicates that the module is in communication with the control panel. The LED latches steady on alarm (subject to current limitations on the loop).

MMF-302(A) SPECIFICATIONS

Nominal operating voltage: 15 to 32 VDC.

Maximum current draw: 5.1 mA (LED on).

Maximum IDC wiring resistance: 25 ohms.

Average operating current: 300 μ A, 1 communication and 1 LED flash every 5 seconds, 3.9k eol.

EOL resistance: 3.9K ohms.

External supply voltage (between Terminals T3 and T4): DC voltage: 24 volts power limited. Ripple voltage: 0.1 Vrms maximum. Current: 90 mA per module maximum.

Temperature range: 32°F to 120°F (0°C to 49°C).

Humidity range: 10% to 93% noncondensing.

Dimensions: 4.5" (11.43 cm) high x 4" (10.16 cm) wide x 1.25" (3.175 cm) deep. Mounts to a 4" (10.16 cm) square x 2.125" (5.398 cm) deep box.

MDF-300(A) Dual Monitor Module

The MDF-300(A) Dual Monitor Module is intended for use in intelligent, two-wire systems. It provides two independent two-wire initiating device circuits (IDCs) at two separate, consecutive addresses. It is capable of monitoring normally open contact fire alarm and supervisory devices. The module has a single panel-controlled LED.

NOTE: The MDF-300(A) provides two Style B (Class B) IDC circuits ONLY. Style D (Class A) IDC circuits are NOT supported in any application.

MDF-300(A) SPECIFICATIONS

Normal operating voltage range: 15 to 32 VDC.

Maximum current draw: 6.4 mA (LED on).

Average operating current: 750 μ A (LED flashing).

Maximum IDC wiring resistance: 1,500 ohms.

Maximum IDC Voltage: 11 Volts.

Maximum IDC Current: 240 μ A

EOL resistance: 47K ohms.

Maximum SLC Wiring resistance: 40 Ohms.

Temperature range: 32° to 120°F (0° to 49°C).

Humidity range: 10% to 93% (non-condensing).

Dimensions: 4.5" (11.43 cm) high x 4" (10.16 cm) wide x 2.125" (5.398 cm) deep.

MDF-300(A) AUTOMATIC ADDRESSING

The MDF-300(A) automatically assigns itself to two addressable points, starting with the original address. For example, if the MDF-300(A) is set to address "26", then it will automatically assign itself to addresses "26" and "27".

NOTE: "Ones" addresses on the MDF-300(A) are 0, 2, 4, 6, or 8 only. Terminals 6 and 7 use the first address, and terminals 8 and 9 use the second address.



CAUTION:

Avoid duplicating addresses on the system.

Installation

MMF-300(A), MMF-302(A), and MDF-300(A) modules mount directly to a standard 4" (10.16 cm) square, 2.125" (5.398 cm) deep, electrical box. They may also be mounted to the SMB500 surface-mount box. Mounting hardware and installation instructions are provided with each module. All wiring must conform to applicable local codes, ordinances, and regulations. These modules are intended for power-limited wiring only.

The MMF-301(A) module is intended to be wired and mounted without rigid connections inside a standard electrical box. All wiring must conform to applicable local codes, ordinances, and regulations.

Agency Listings and Approvals

In some cases, certain modules may not be listed by certain approval agencies, or listing may be in process. Consult factory for latest listing status.

- **UL:** S2424
- **ULC:** S2424
- **FM Approved**
- **CSFM:** 7300-0075:0185
- **MEA:** 72-01-E

Product Line Information

NOTE: "A" suffix indicates ULC-listed model.

MMF-300(A): Monitor module.

MMF-301(A): Monitor module, miniature.

MMF-302(A): Monitor module, two-wire detectors.

MDF-300(A): Monitor module, dual, two independent Class B circuits.

SMB500: Optional surface-mount backbox.

NOTE: See installation instructions and refer to the SLC Wiring Manual, PN 51309.

Architects'/Engineers' Specifications

Specifications of these devices and all FireLite products are available from FireLite.

Fire-Lite® and LiteSpeed® are registered trademarks and FireWatch™ is a trademark of Honeywell International Inc.
©2010 by Honeywell International Inc. All rights reserved. Unauthorized use of this document is strictly prohibited.



This document is not intended to be used for installation purposes.
We try to keep our product information up-to-date and accurate.
We cannot cover all specific applications or anticipate all requirements.
All specifications are subject to change without notice.



For more information, contact Fire•Lite Alarms. Phone: (800) 627-3473, FAX: (877) 699-4105.
www.firelite.com



L-Series and L-Series with LED Indoor Selectable Horns, Strobes and Horn Strobes

System Sensor L-Series and L-Series with LED audible visible notification products are rich with features guaranteed to cut installation times and maximize profits with lower current draw and modern aesthetics.



Features

- LED technology provides lower current draw
- Digital Voltage Meter (DVM) diagnostic test points for Horn Strobes and Strobes
- Common aesthetics across the L-Series platform
- Standard and compact sizes
- Tamper-resistant construction
- Field-selectable candela settings on wall units: 15, 30, 75, 95, 110, 135, and 185
- Field-selectable candela settings on ceiling units: 15, 30, 75, 95, 115, 150, and 177
- Rotary switches for candela, tone and volume selections
- Mounting plate provides plug-in design for easier installation and shorting springs to check wiring continuity
- Electrically compatible with legacy SpectrAlert, SpectrAlert Advance and L-series devices
- Synchronization through use of UL approved power supplies that support System Sensor Sync protocol or System Sensor MDL3 Sync Module
- Horns, Strobes and Horn Strobes listed for wall or ceiling use

The System Sensor L-Series and L-Series with LED platform

offers the most versatile and easy-to-use line of horns, strobes, and horn strobes in the industry with lower current draw and modern aesthetics. LED lighting technology offers significantly lower current draw compared to older Xenon bulbs across a full candela range. This improves design flexibility for notification appliance circuits (NACs) while also reducing power supply requirements allowing for simpler and lower cost installations.

Flexible design options meet virtually any application requirement: wall or ceiling mount, standard or compact sizes, red or white color choices, bezel kits for alternate markings and languages, and LED color lenses for distinctive visual signaling. In addition, installers can easily adapt devices using field selectable candela, tone and volume settings using rotary switches.

The L-Series and L-Series with LED line is developed to simplify installation. All devices feature plug-in designs with minimal intrusion into the back box, making installations fast and foolproof while virtually eliminating costly and time-consuming ground faults. The universal mounting plate includes an onboard shorting spring, so installers can test wiring continuity before the device is installed.

In addition, the System Sensor L-Series with LED notification appliances offer a new diagnostic test point feature that allows you to measure device voltage with a digital voltage meter (DVM) without removing the appliance from the wall or ceiling. The DVM test points are discreetly located on the face of the notification appliance which enable faster troubleshooting and end of line (EOL) voltage checks while greatly reducing the risk of misplacing or damaging appliances during troubleshooting.

Agency Listings



L-Series and L-Series with LED Specifications

Physical/Electrical Specifications	
Standard Operating Temperature	32°F to 120°F (0°C to 49°C)
Humidity Range	10 to 93% non-condensing
Strobe Flash Rate	1 flash per second
Nominal Voltage, LED Strobes and Horn Strobes	Regulated 24 VDC
Nominal Voltage, Horns	Regulated 12 VDC or regulated 24 DC/FWR
Operating Voltage Range, LED Strobes and Horn Strobes	16 to 33 V (24 V nominal)
Operating Voltage Range, Horns	8 to 17.5 V (12 V nominal) or 16 to 33 V (24 V nominal)
Input Terminal Wire Gauge	12 to 18 AWG

UL/ULC Current Draw Data, Horn Tones, and Sound Output Data

UL/ULC Maximum Strobe Current Draw (mA)			
Candela Range	Candela Rating	16–33 Volts	
		Wall	Ceiling
Candela Range	15	18	18
	30	22	22
	75	70	70
	95	75	75
	110	85	—
	115	—	90
	135	105	—
	150	—	110
	177	—	115
	185	120	—

UL/ULC Maximum Horn Current Draw (mA RMS)				
Sound Pattern	dB	8–17.5 Volts		
		DC	DC	FWR
Temporal	High	39	44	54
Temporal	Low	28	32	54
Non-Temporal	High	43	47	54
Non-Temporal	Low	29	32	54
3.1 KHz Temporal	High	39	41	54
3.1 KHz Temporal	Low	29	32	54
3.1 KHz Non-Temporal	High	42	43	54
3.1 KHz Non-Temporal	Low	28	29	54
Coded	High	43	47	54
3.1 KHz Coded	High	42	43	54

UL/ULC Maximum Horn Strobe Current Draw (mA) and Sound Output (dBA)														
Switch Pos.	Sound Pattern	Volume Setting	Current Draw (mA RMS), Horn Strobe, Candela Range (15-185 cd)										Sound Output (dBA)	
			16-33 Volts											16-33V DC
			15cd	30cd	75cd	95cd	110cd	115cd	135cd	150cd	177cd	185cd		
			WALL	CEILING	WALL	CEILING	WALL	CEILING	CEILING	WALL				
1	Temporal 3	High	35	38	87	92	94	120	189	189	190	190	87	
2	Temporal 3	Low	35	38	87	92	94	120	135	135	145	145	79	
3	Non-Temporal	High	50	52	87	92	94	120	127	127	135	135	87	
4	Non-Temporal	Low	35	38	87	92	94	120	125	125	130	130	79	
5	3.1KHz Temporal 3	High	35	38	87	89	91	115	155	155	165	165	86	
6	3.1KHz Temporal 3	Low	35	38	87	89	91	115	128	130	135	135	80	
7	3.1KHz Non-Temporal	High	40	42	87	89	91	115	125	125	135	135	86	
8	3.1KHz Non-Temporal	Low	35	38	87	89	91	115	120	120	130	130	80	

L-Series with LED Dimensions: Wall-Mounted Equipment

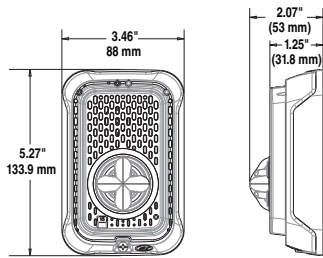

A0617-00

**Compact Strobe, Horn Strobe
for Wall**

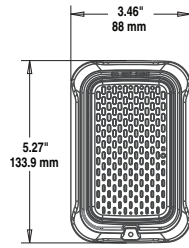

A0547-00

Compact Horn

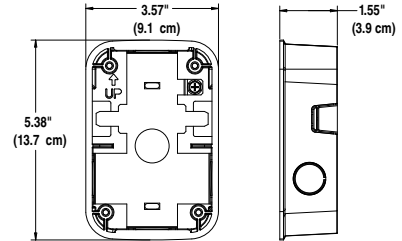

A0557-00

**Compact Surface Mount Back Box
for Walls (SBBGRL, SBBGWL)**

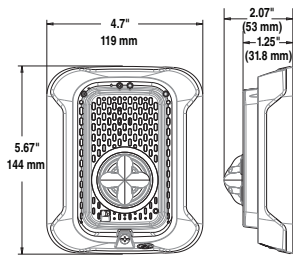

A0613-00

**Strobes, Horn Strobes
for Walls**

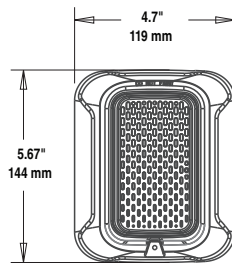

A0549-00

Horn

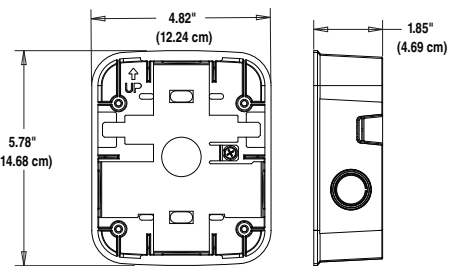

A0554-01

**Surface Mount Back Box
for Walls (SBBRL/SBBWL)**

L-Series with LED Dimensions: Ceiling-Mounted Equipment

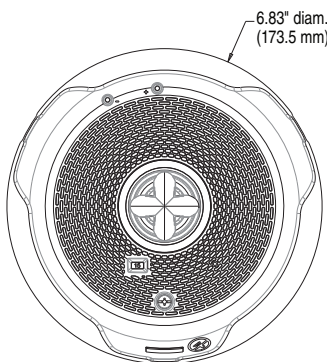

A0608-00

**Strobes and Horn Strobes
for Ceilings**

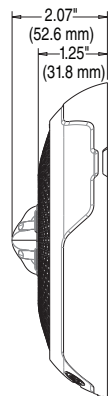

6.92" diam.
(175.77 mm)

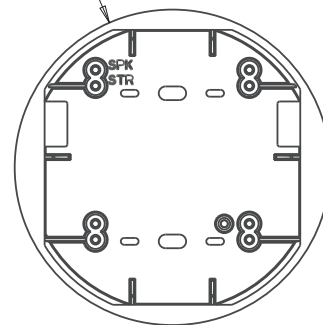

A0546-00

**Surface Mount Back Box
for Ceilings (SBBCRL, SBCWL)**

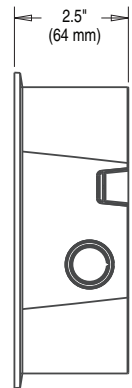

L-Series with LED: Ordering Information

Model	Description
L-Series with LED Horn Strobes	
P2RLED	2-Wire, Horn Strobe, Wall, Red
P2RLED-B	2-Wire, Horn Strobe, Wall, Red, Bilingual
P2WLED	2-Wire, Horn Strobe, Wall, White
P2WLED-B	2-Wire, Horn Strobe, Wall, White, Bilingual
P2GRLED	2-Wire, Compact Horn Strobe, Wall, Red
P2GRLED-B	2-Wire, Compact Horn Strobe, Wall, Red, Bilingual
P2GWLED	2-Wire, Compact Horn Strobe, Wall, White
P2GWLED-B	2-Wire, Compact Horn Strobe, Wall, White, Bilingual
P2RLED-P	2-Wire, Horn Strobe, Wall, Red, Plain
P2WLED-P	2-Wire, Horn Strobe, Wall, White, Plain
P2RLED-SP	2-Wire, Horn Strobe, Wall, Red, FUEGO
P2WLED-SP	2-Wire, Horn Strobe, Wall, White, FUEGO
PC2RLED	2-Wire, Horn Strobe, Ceiling, Red
PC2RLED-B	2-Wire, Horn Strobe, Ceiling, Red, Bilingual
PC2WLED	2-Wire, Horn Strobe, Ceiling, White
PC2WLED-B	2-Wire, Horn Strobe, Ceiling, White, Bilingual
L-Series with LED Strobes	
SRLED	Strobe, Wall, Red
SRLED-B	Strobe, Wall, Red, Bilingual
SWLED	Strobe, Wall, White
SWLED-B	Strobe, Wall, White, Bilingual
SGRLED	Strobe, Compact, Wall, Red
SGRLED-B	Strobe, Compact, Wall, Red, Bilingual
SGWLED	Strobe, Compact, Wall, White
SGWLED-B	Strobe, Compact, Wall, White, Bilingual
SRLED-P	Strobe, Wall, Red, Plain
SWLED-P	Strobe, Wall, White, Plain
SRLED-SP	Strobe, Wall, Red, FUEGO
SWLED-CLR-ALERT	Strobe, Wall, White, ALERT
SWLED-ALERT	Strobe, Wall, White, ALERT, Amber Lens
SCRLED	Strobe, Ceiling, Red
SCRLED-B	Strobe, Ceiling, Red, Bilingual
SCRLED-P	Strobe, Ceiling, White, Plain
SCWLED	Strobe, Ceiling, White
SCWLED-B	Strobe, Ceiling, White, Bilingual
SCWLED-P	Strobe, Ceiling, White, Plain
SCWLED-CLR-ALERT	Strobe, Ceiling, White, ALERT
L-Series Horns	
HRL*	Horn, Red
HRLA*	Horn, Red, Plain, ULC
HWL*	Horn, White
HWLA*	Horn, White, Plain, ULC
HGRL*	Compact Horn, Red
HGRLA*	Compact Horn, Red, Plain, ULC
HGWL*	Compact Horn, White
HGWLA*	Compact Horn, White, Plain, ULC

Model	Description
LED Lenses	
LENS-A3	Lens LED Amber Wall/Ceiling
LENS-B3	Lens LED Blue Wall/Ceiling
LENS-G3	Lens LED Green Wall/Ceiling
LENS-R3	Lens LED Red Wall/Ceiling
Accessories	
TR-2	Universal Wall Trim Ring Red
TR-2W	Universal Wall Trim Ring White
SBBRL	Wall Surface Mount Back Box, Red
SBBWL	Wall Surface Mount Back Box, White
SBBGRL	Compact Wall Surface Mount Back Box, Red
SBBGWL	Compact Wall Surface Mount Back Box, White
TRC-2	Universal Ceiling Trim Ring, Red
TRC-2W	Universal Ceiling Trim Ring, White
SBBCRL	Ceiling Surface Mount Back Box, Red
SBBCWL	Ceiling Surface Mount Back Box, White
Bezels†	
BZR	Wall Red Bezel Kit
BZW	Wall White Bezel Kit
BZGR	Compact Wall Red Bezel Kit
BZGW	Compact Wall White Bezel Kit
BZRC	Horn Strobe Ceiling Red Bezel Kit
BZWC	Horn Strobe Ceiling White Bezel Kit

Notes for L-Series With LED Horn Strobes and Strobes:

All -P models have a plain housing (no "FIRE" marking on cover).
 All -SP models have "FUEGO" marking on cover.
 All -ALERT models have "ALERT" marking on cover.
 All -B models have "FIRE/FEU" marking on cover for use in Canadian applications.
 Amber lenses are not for use in Canadian applications

Notes for L-Series Horns:

*Horn-only models are listed for wall or ceiling use.

Notes for Bezels:

†Each bezel pack ships in a package of 5.
 Add one of the following extensions for print/language options: -F (FIRE), -AL (ALERT), -EV (EVAC), -AG (AGENT), -P (Plain), -FR (FEU), -PG (FOGO), -SP (FUEGO), -SPE (FUEGO/FIRE).

3825 Ohio Avenue • St. Charles, IL 60174 USA
 Phone: 800-SENSOR2 • Fax: 630-377-6495
www.systemsensor.com

3333 Unity Drive, Mississauga, ON L5L 3S6 Canada
 Phone: 800-SENSOR2 • Fax: 905-812-0771
www.systemsensor.ca

System Sensor® is a registered trademark
 of Honeywell International, Inc.



©2023 System Sensor.
 Product specifications subject to change without notice. Visit www.systemsensor.com
 for current product information, including the latest version of this data sheet.
 AVDS916-01 • 10/03/2023

FIRE ALARM SUBMITTAL



113 Walter Street
Whiteville, NC 28472

www.tritekfire.com

Phone: (910) 207-6290
Columbia: (803) 407-0747
Florence: (843) 664-8811
Augusta, GA: (706) 722-4464
WATS SC/GA (888) 874-8353

WIRE SUBMITTAL

PART NUMBER 762360

UL Listed and Rated Type FPLP Multi-Conductor Non-Shielded Plenum Fire Alarm



CABLE SPECIFICATIONS

DESCRIPTION	18 AWG 2 Conductor Bare Copper, Non-Shielded Plenum Fire Alarm, FPLP (UL)
CONDUCTOR	18 (Solid Bare Copper)
INSULATION	Low-Smoke PVC .010"
COLOR CODE	Black/Red
SHIELD	N/A
DRAIN WIRE	N/A
JACKET	Low-Smoke PVC .018"
JACKET COLOR	Red Jacket
MARKING	FIRE/LIFE SAFETY CONTROL CABLE INIT. / IND. DEVICE / ZONE A B C D E 0 1 2 3 4 5 6 7 8 9 18 AWG FPLP (UL) - ROHS MADE IN THE USA
OVERALL DIAMETER	.158" Nom.
CABLE WEIGHT	22 Lbs/Mft.
CAPACITANCE	22 pF/Ft. Nom.
IMPEDANCE	86 Ohms/Mft.
DC RESISTANCE	6.52 Ohms/Mft @ 20 deg. C
TEMPERATURE RATING	0 C to 75 C / 300 Volt

INDUSTRY STANDARDS

FLAME RATING	Approved For Plenum Use Without Conduit Per NFPA 262 Flame Test
AGENCY APPROVALS	NEC Article 800, 760; FPLP (UL), RoHS Compliant, Made in the USA



All specifications referenced are nominal measurements unless otherwise noted.

PART NUMBER 767960

UL Listed and Rated Type FPLP Multi-Conductor Non-Shielded Plenum Fire Alarm



CABLE SPECIFICATIONS

DESCRIPTION	14 AWG 2 Conductor Bare Copper, Non-Shielded Plenum Fire Alarm, FPLP (UL)
CONDUCTOR	14 (Solid Bare Copper)
INSULATION	Low-Smoke PVC .010"
COLOR CODE	Black/Red
SHIELD	N/A
DRAIN WIRE	N/A
JACKET	Low-Smoke PVC .018"
JACKET COLOR	Red Jacket
MARKING	FIRE/LIFE SAFETY CONTROL CABLE INIT. / IND. DEVICE / ZONE A B C D E 0 1 2 3 4 5 6 7 8 9 14 AWG FPLP (UL) - ROHS MADE IN THE USA
OVERALL DIAMETER	.206" Nom
CABLE WEIGHT	36 Lbs/Mft.
CAPACITANCE	26 pF/Ft. Nom.
IMPEDANCE	72 Ohms/Mft.
DC RESISTANCE	2.57 Ohms/Mft @ 20 deg. C
TEMPERATURE RATING	0 C to 75 C / 300 Volt

INDUSTRY STANDARDS

FLAME RATING	Approved For Plenum Use Without Conduit Per NFPA 262 Flame Test
AGENCY APPROVALS	NEC Article 800, 760; FPLP (UL), RoHS Compliant, Made in the USA



All specifications referenced are nominal measurements unless otherwise noted.

PART NUMBER 7623890

UL Listed and Rated Type FPLP Multi-Conductor Non-Shielded Plenum Fire Alarm

■ 0275/0725 FT ● FIRE/LIFE SAFETY CONTROL CABLE INIT/IND DEVICE/ZONE ABCDE0123456789

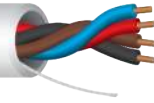

CABLE SPECIFICATIONS

DESCRIPTION	18 AWG 4 Conductor Bare Copper, Non-Shielded Plenum Fire Alarm, FPLP (UL)
CONDUCTOR	18 (Solid Bare Copper)
INSULATION	Low-Smoke PVC .010"
COLOR CODE	Black/Red/Brown/Blue
SHIELD	N/A
DRAIN WIRE	N/A
JACKET	Low-Smoke PVC .018"
JACKET COLOR	White Jacket
MARKING	FIRE/LIFE SAFETY CONTROL CABLE INIT. / IND. DEVICE / ZONE A B C D E 0 1 2 3 4 5 6 7 8 9 18 AWG FPLP (UL) - ROHS MADE IN THE USA
OVERALL DIAMETER	.184" Nom.
CABLE WEIGHT	35 Lbs/Mft.
CAPACITANCE	22 pF/Ft. Nom.
IMPEDANCE	86 Ohms
TEMPERATURE RATING	0 C to 75 C / 300 Volt

INDUSTRY STANDARDS

FLAME RATING	Approved For Plenum Use Without Conduit Per NFPA 262 Flame Test
AGENCY APPROVALS	NEC Article 760; FPLP (UL), RoHS Compliant, Made in the USA



All specifications referenced are nominal measurements unless otherwise noted.



113 Walter Street
Whiteville, NC 28472

www.tritekfire.com

Phone: (910) 207-6290
Columbia: (803) 407-0747
Florence: (843) 664-8811
Augusta, GA: (706) 722-4464
WATS SC/GA (888) 874-8353

CALCULATIONS

FACP BATTERY CALCULATIONS

Project #: 30784	Project Name: 3266 RAY ROAD	Date: 12/10/2024							
Panel Label: FACP	Model Number: ES-200X	Calculations provided by Tritex Fire & Security							
Standby Hours: 24	Alarm Minutes: 5								
Device Type	STANDBY CURRENT PER UNIT (AMPS)	QTY	=	TOTAL STANDBY CURRENT PER ITEM	ALARM CURRENT PER UNIT (AMPS)	QTY	=	TOTAL ALARM CURRENT PER ITEM	
ES-200X	0.18100	x 1	=	0.18100	0.29800	x 1	=	0.29800	
STARLINK	0.10000	x 1	=	0.10000	0.20000	x 1	=	0.20000	
N-ANN-80	0.01500	x 1	=	0.01500	0.04000	x 1	=	0.04000	
MAX SLC	0.00000	x 1	=	0.00000	0.40000	x 1	=	0.40000	
P2RLED75	0.00000	x 1	=	0.00000	0.08700	x 1	=	0.08700	
PC2RLED15	0.00000	x 8	=	0.00000	0.03500	x 8	=	0.28000	
PC2RLED30	0.00000	x 2	=	0.00000	0.03800	x 2	=	0.07600	
PC2RLED75	0.00000	x 9	=	0.00000	0.08700	x 9	=	0.78300	
SCRLED15	0.00000	x 8	=	0.00000	0.01800	x 8	=	0.14400	
	0.00000	x 0	=	0.00000	0.00000	x 0	=	0.00000	
TOTAL SYSTEM STANDBY CURRENT (AMPS)				0.2960	TOTAL SYSTEM ALARM CURRENT (AMPS)				2.3080
REQUIRED STANDBY TIME (HRS) NFPA 72	TOTAL SYSTEM STANDBY CURRENT (AMPS)	REQUIRED STANDBY CAPACITY (AMP-HOURS)	REQUIRED ALARM TIME (HOURS) NFPA 72	TOTAL SYSTEM ALARM CURRENT (AMPS)	REQUIRED ALARM CAPACITY (AMP-HOURS)				
24	x 0.2960	= 7.1040	0.083	x 2.3080	= 0.1916				
REQUIRED STANDBY CAPACITY (AMP-HOURS)	REQUIRED ALARM CAPACITY (AMP-HOURS)	TOTAL CAPACITY (AMP-HOURS)	SAFETY FACTOR	ADJUSTED BATTERY CAPACITY (AMP-HOURS)					
7.10	+ 0.1916	= 7.2956	x 120%	= 8.755					
BATTERY SUPPLIED FOR PROJECT					12AH				

VOLTAGE DROP CALCULATIONS

Project #: 30784		Project Name: 3266 RAY ROAD			Date: 12/10/2024		Calculations provided by Tritek Fire & Security				
Panel Label:	FACP	Model #: ES-200X			Point to Point Method		End of Line Method		Load Centering Method		
Circuit Number as noted on drawings:	AA	Location of Circuit: FAMILY DOLLAR			CIRCUIT IS WITHIN LIMITS		CIRCUIT IS WITHIN LIMITS		CIRCUIT IS WITHIN LIMITS		
Total Amp Per Ckt:		2	Amps			Totals		Totals		Totals	
Nominal System Voltage:		20.4	Volts			Voltage Drop		Voltage Drop		Voltage Drop	
Minimum Device Voltage:		16	Volts			Current		Current		Current	
Total Circuit Current:		0.935	Amps			Distance		Distance		Distance	
Distance from source to 1st device:		55	Ft			Drop		Drop		Drop	
Standby:		24	Hours			End of Line Voltage		End of Line Voltage		End of Line Voltage	
Alarm:		5	Minutes			Percent Drop		Percentage Drop		Percentage Drop	
						Wire Gauge		Ohm's Per 1000			
						14		2.525			
						14		2.525			
Enter current in amps .150 = 150 ma				Distance from previous device	Voltage						
Device Number	Part Number	Candela	Device Current		At Device	Drop from source	Percent Drop				
Device 1	P2RLED	75	0.087	55	20.14	0.260	1.27%				
Device 2	SCRLED	15	0.018	75	19.82	0.581	2.85%				
Device 3	SCRLED	15	0.018	20	19.74	0.665	3.26%				
Device 4	SCRLED	15	0.018	25	19.63	0.767	3.76%				
Device 5	PC2RLED	75	0.087	45	19.45	0.948	4.64%				
Device 6	PC2RLED	75	0.087	45	19.29	1.108	5.43%				
Device 7	PC2RLED	75	0.087	45	19.15	1.249	6.12%				
Device 8	PC2RLED	75	0.087	40	19.04	1.357	6.65%				
Device 9	PC2RLED	75	0.087	45	18.94	1.458	7.15%				
Device 10	PC2RLED	75	0.087	45	18.86	1.540	7.55%				
Device 11	PC2RLED	75	0.087	40	18.81	1.595	7.82%				
Device 12	PC2RLED	75	0.087	45	18.76	1.637	8.02%				
Device 13	PC2RLED	75	0.087	45	18.74	1.659	8.13%				
Device 14	EOL 4.7K		0.011	1	18.74	1.659	8.13%				
None					18.74	1.659	8.13%				
None					18.74	1.659	8.13%				
None					18.74	1.659	8.13%				
None					18.74	1.659	8.13%				
None					18.74	1.659	8.13%				
None					18.74	1.659	8.13%				
None					18.74	1.659	8.13%				
None					18.74	1.659	8.13%				
		Totals:	0.935	571	End of Line Voltage		18.74				

Totals		Voltage Drop	Totals		Voltage Drop	Totals		Voltage Drop
Current	Distance		Current	Distance		Current	Distance	
0.935	571	1.66	0.935	571	1.348	0.935	571	1.348
End of Line Voltage		18.74	End of Line Voltage		19.05	End of Line Voltage		19.05
Percent Drop		8.13%	Percentage Drop		6.61%	Percentage Drop		6.61%

End of Line and Load Centering Methods use only the wire gauge for the first device to source
Standard Wire Resistance in Ohms per 1000 feet.
18=6.385 16=4.016 14=2.525 12=1.59 10=0.99
18-14 Awg = Solid Conductors 12-10 Awg = Stranded Conductors

Notes:
Wire resistance is doubled in the calculations for two wires (Positive and Negative). The voltage calculated to the last device in any method must not be lower than the manufacturers listed minimum operating voltage (IE: rated operating voltage 20-32 VDC).

Spare Capacity

Minimum Spare Capacity Required	20%
Current Draw Capacity Used	47%
Capacity (Not including Spare)	33%

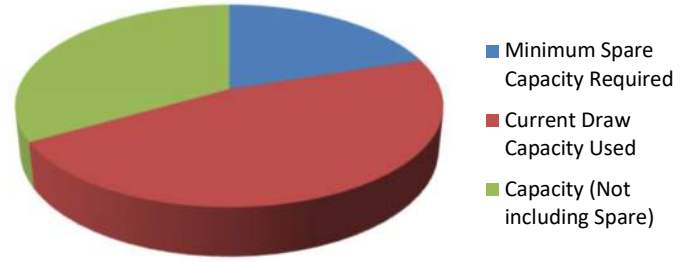

VOLTAGE DROP CALCULATIONS

Project #: 30784		Project Name: 3266 RAY ROAD			Date: 12/10/2024		Calculations provided by Tritek Fire & Security		
Panel Label:	FACP	Model #: ES-200X			Point to Point Method		End of Line Method		Load Centering Method
Circuit Number as noted on drawings:	AB	Location of Circuit: MINDFUL THERAPY			CIRCUIT IS WITHIN LIMITS		CIRCUIT IS WITHIN LIMITS		CIRCUIT IS WITHIN LIMITS
Total Amp Per Ckt:		2	Amps		Totals		Totals		Totals
Nominal System Voltage:		20.4	Volts		Current		Distance		Voltage Drop
Minimum Device Voltage:		16	Volts		0.158		266		0.16
Total Circuit Current:		0.158	Amps		End of Line Voltage		End of Line Voltage		End of Line Voltage
Distance from source to 1st device:		130	Ft		20.24		20.29		20.29
Standby:		24	Hours		Percent Drop		Percentage Drop		Percentage Drop
Alarm:		5	Minutes		0.79%		0.52%		0.52%
Wire Gauge for balance of circuit:		14	Wire Gauge		14		2.525		2.525
Enter current in amps		.150 = 150 ma		Distance from previous device		Voltage			
Device Number	Part Number	Candela	Device Current	Distance from previous device	At Device	Drop from source	Percent Drop		
Device 1	PC2RLED	15	0.035	130	20.30	0.104	0.51%		
Device 2	SCRLED	15	0.018	25	20.28	0.119	0.58%		
Device 3	SCRLED	15	0.018	25	20.27	0.132	0.65%		
Device 4	PC2RLED	30	0.038	45	20.25	0.152	0.75%		
Device 5	PC2RLED	30	0.038	40	20.24	0.162	0.79%		
Device 6	EOL 4.7K	1	0.011	1	20.24	0.162	0.79%		
None					20.24	0.162	0.79%		
None					20.24	0.162	0.79%		
None					20.24	0.162	0.79%		
None					20.24	0.162	0.79%		
None					20.24	0.162	0.79%		
None					20.24	0.162	0.79%		
None					20.24	0.162	0.79%		
None					20.24	0.162	0.79%		
None					20.24	0.162	0.79%		
None					20.24	0.162	0.79%		
None					20.24	0.162	0.79%		
None					20.24	0.162	0.79%		
None					20.24	0.162	0.79%		
None					20.24	0.162	0.79%		
Totals:		0.158	266		End of Line Voltage		20.24		

Notes:
 Wire resistance is doubled in the calculations for two wires (Positive and Negative). The voltage calculated to the last device in any method must not be lower than the manufacturers listed minimum operating voltage (IE: rated operating voltage 20-32 VDC).

Spare Capacity

Minimum Spare Capacity Required	20%
Current Draw Capacity Used	8%
Capacity (Not including Spare)	72%

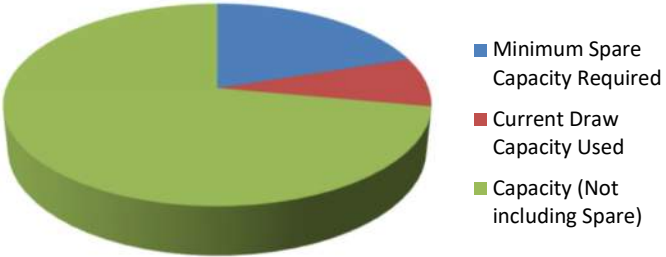

VOLTAGE DROP CALCULATIONS

Project #: 30784		Project Name: 3266 RAY ROAD			Date: 12/10/2024		Calculations provided by Tritek Fire & Security				
Panel Label:	FACP	Model #: ES-200X			Point to Point Method		End of Line Method		Load Centering Method		
Circuit Number as noted on drawings:	AC	Location of Circuit: LITTLE HEATHENS BREWERY			CIRCUIT IS WITHIN LIMITS		CIRCUIT IS WITHIN LIMITS		CIRCUIT IS WITHIN LIMITS		
Total Amp Per Ckt		2	Amps			Totals		Totals		Totals	
Nominal System Voltage:		20.4	Volts			Current	Distance	Voltage Drop	Current	Distance	Voltage Drop
Minimum Device Voltage:		16	Volts			0.310	446	0.47	0.310	446	0.349
Total Circuit Current:		0.310	Amps			End of Line Voltage		End of Line Voltage		End of Line Voltage	
Distance from source to 1st device:		145	Ft			19.93	20.05	20.05	20.05	20.05	20.05
Standby:		24	Hours			Percent Drop	2.30%	Percentage Drop	1.71%	Percentage Drop	1.71%
Alarm:		5	Minutes			Wire Gauge	14	Ohm's Per 1000	2.525		
						Wire Gauge for balance of circuit:	14	2.525			
Enter current in amps				Distance from previous device	Voltage						
.150 = 150 ma					At Device	Drop from source	Percent Drop				
Device Number	Part Number	Candela	Device Current								
Device 1	PC2RLED	15	0.035	145	20.17	0.227	1.11%				
Device 2	PC2RLED	15	0.035	45	20.11	0.289	1.42%				
Device 3	PC2RLED	15	0.035	40	20.06	0.338	1.66%				
Device 4	PC2RLED	15	0.035	35	20.03	0.374	1.83%				
Device 5	PC2RLED	15	0.035	40	19.99	0.408	2.00%				
Device 6	SCRLED	15	0.018	30	19.97	0.429	2.10%				
Device 7	PC2RLED	15	0.035	30	19.95	0.447	2.19%				
Device 8	PC2RLED	15	0.035	30	19.94	0.459	2.25%				
Device 9	SCRLED	15	0.018	25	19.94	0.465	2.28%				
Device 10	SCRLED	15	0.018	25	19.93	0.469	2.30%				
Device 11	EOL 4.7K	1	0.011	1	19.93	0.469	2.30%				
None					19.93	0.469	2.30%				
None					19.93	0.469	2.30%				
None					19.93	0.469	2.30%				
None					19.93	0.469	2.30%				
None					19.93	0.469	2.30%				
None					19.93	0.469	2.30%				
None					19.93	0.469	2.30%				
None					19.93	0.469	2.30%				
None					19.93	0.469	2.30%				
None					19.93	0.469	2.30%				
None					19.93	0.469	2.30%				
		Totals:	0.310	446	End of Line Voltage	19.93					

Totals		Voltage Drop	Totals		Voltage Drop	Totals		Voltage Drop
Current	Distance	Drop	Current	Distance	Drop	Current	Distance	Drop
0.310	446	0.47	0.310	446	0.349	0.310	446	0.349
End of Line Voltage		19.93	End of Line Voltage		20.05	End of Line Voltage		20.05
Percent Drop		2.30%	Percentage Drop		1.71%	Percentage Drop		1.71%

End of Line and Load Centering Methods use only the wire gauge for the first device to source
 Standard Wire Resistance in Ohms per 1000 feet.
 18=6.385 16=4.016 14=2.525 12=1.59 10=0.99
 18-14 Awg = Solid Conductors 12-10 Awg = Stranded Conductors

Notes:
 Wire resistance is doubled in the calculations for two wires (Positive and Negative). The voltage calculated to the last device in any method must not be lower than the manufacturers listed minimum operating voltage (IE: rated operating voltage 20-32 VDC).

Spare Capacity

Minimum Spare Capacity Required	20%
Current Draw Capacity Used	15%
Capacity (Not including Spare)	65%

