



Raleigh: 1609 Heritage Commerce Ct | Wake Forest, NC 27587 | Tel: 919.872.3250  
[www.SummitFireSecurity.com](http://www.SummitFireSecurity.com)

# FAIRWAY POINTE BLDG 13

200 GALLERY DR  
SPRING LAKE, NC 28390

## **SUBMITTAL PACKAGE**

PRODUCT DATA  
&  
HYDRAULIC CALCULATIONS



## TECHNICAL DATA

## FREEDOM® RESIDENTIAL PENDENT SPRINKLER VK468 (K4.9)

The Viking Corporation, 210 N Industrial Park Drive, Hastings MI 49058

Telephone: 269-945-9501 Technical Services: 877-384-5464 Fax: 269-818-1680 Email: techsvcs@vikingcorp.com

Visit the Viking website for the latest edition of this technical data page [www.vikinggroupinc.com](http://www.vikinggroupinc.com)

### 1. DESCRIPTION

Viking Freedom® Residential Pendent Sprinkler VK468 is a small, thermosensitive, glass-bulb residential sprinkler available in several different finishes and temperature ratings to meet varying design requirements. The Electroless Nickel PTFE (ENT) coating has been investigated for installation in corrosive atmospheres and is C-UL-US-EU Listed as corrosion resistant as indicated in the Approval Chart. The orifice design, with a K-Factor of 4.9 (70.6 metric†), allows efficient use of available water supplies for the hydraulically designed fire-protection system. The glass bulb operating element and special deflector characteristics meet the challenges of residential sprinkler standards.

### 2. LISTINGS AND APPROVALS



**UL Listed (C-UL-US-EU):** Category VKKW



**VdS Approved**

**NYC Approved:** MEA 89-92-E, Volume 35

**UL Classified to:** NSF/ANSI Standard 61, Drinking Water System Components (MH48034).



**WARNING:** Cancer and Reproductive Harm-  
[www.P65Warnings.ca.gov](http://www.P65Warnings.ca.gov)

Refer to the Approval Chart and Design Criteria for C-UL-US-EU Listing requirements that must be followed.

### 3. TECHNICAL DATA

#### Specifications:

Available since 2006.

Minimum Operating Pressure: Refer to the Approval Chart.

Maximum Working Pressure: 175 psi (12 bar). Factory tested hydrostatically to 500 psi (34.5 bar).

Thread size: 1/2" (15 mm) NPT

Nominal K-Factor: 4.9 U.S. (70.6 metric†)

†Metric K-factor measurement shown is in Bar. When pressure is measured in kPa, divide the metric K-factor shown by 10.0.

Glass-bulb fluid temperature rated to -65 °F (-55 °C)

Overall Length: 2-1/4" (58 mm)

#### Material Standards:

Frame Casting: Brass UNS-C84400 or QM Brass

Deflector: Brass UNS-C23000, Phosphor Bronze UNS-C51000, or Brass UNS-C26000

Bulb: Glass, nominal 3 mm diameter

Belleville Spring Sealing Assembly: Nickel Alloy, coated on both sides with Polytetrafluoroethylene (PTFE) Tape

Pip Cap and Insert Assembly: Copper UNS-C11000 and Stainless Steel UNS-S30400

Compression Screw: Brass UNS-C36000

For ENT coated sprinklers: Belleville spring - Exposed. Screw and Pipcap - ENT plated.

**Ordering Information:** (Also refer to the current Viking price list.)

**Sprinkler:** Base Part No. 13637

Order Sprinkler VK468 by first adding the appropriate suffix for the sprinkler finish and then the appropriate suffix for the temperature rating to the sprinkler base part number.

Finish Suffix: Brass = A, Chrome = F, White Polyester = M-/W, Black Polyester = M-/B, and ENT = JN

Temperature Suffix: 155 °F (68 °C) = B, 175 °F (79 °C) = D

For example, sprinkler VK468 with a Brass finish and a 155 °F (68 °C) temperature rating = Part No. 13637AB.

#### Available Finishes And Temperature Ratings:

Refer to Table 1.

**Accessories:** (Also refer to the Viking website.)

#### Sprinkler Wrenches:

A. Standard Wrench: Part No. 21475M/B (available since 2017)

B. Wrench for recessed sprinklers: Part No. 13577W/B\* (available since 2006)

C. Optional Protective Sprinkler Cap Remover/Escutcheon Installer Tool\*\* Part No. 15915 (available since 2010.)

\*A 1/2" ratchet is required (not available from Viking).

\*\*Allows use from the floor by attaching a length of 1" diameter CPVC tubing to the tool. Ideal for sprinkler cabinets. Refer to Bulletin F\_051808.

	<b>TECHNICAL DATA</b>	<b>FREEDOM® RESIDENTIAL PENDENT SPRINKLER VK468 (K4.9)</b>
---	-----------------------	--

**The Viking Corporation, 210 N Industrial Park Drive, Hastings MI 49058**  
**Telephone: 269-945-9501 Technical Services: 877-384-5464 Fax: 269-818-1680 Email: techsvcs@vikingcorp.com**  
**Visit the Viking website for the latest edition of this technical data page [www.vikinggroupinc.com](http://www.vikinggroupinc.com)**

**Sprinkler Cabinets:**

- A. Six-head capacity: Part No. 01724A (available since 1971)
- B. Twelve-head capacity: Part No. 01725A (available since 1971)

**4. INSTALLATION**

Refer to appropriate NFPA Installation Standards.

**5. OPERATION**

During fire conditions, the heat-sensitive liquid in the glass bulb expands, causing the glass to shatter, releasing the pip cap and sealing spring assembly. Water flowing through the sprinkler orifice strikes the sprinkler deflector, forming a uniform spray pattern to extinguish or control the fire.

**6. INSPECTIONS, TESTS AND MAINTENANCE**

Refer to NFPA 25 for Inspection, Testing and Maintenance requirements.

**7. AVAILABILITY**

The Viking Model VK468 Sprinkler is available through a network of domestic and international distributors. See The Viking Corporation web site for the closest distributor or contact The Viking Corporation.

**8. GUARANTEE**

For details of warranty, refer to Viking's current list price schedule or contact Viking directly.

**TABLE 1: AVAILABLE SPRINKLER TEMPERATURE RATINGS AND FINISHES**

Sprinkler Temperature Classification	Sprinkler Nominal Temperature Rating <sup>1</sup>	Maximum Ambient Ceiling Temperature <sup>2</sup>	Bulb Color
Ordinary	155 °F (68 °C)	100 °F (38 °C)	Red
Intermediate	175 °F (79 °C)	150 °F (65 °C)	Yellow

**Sprinkler Finishes:** Brass, Chrome, White Polyester <sup>3</sup>, Black Polyester <sup>3</sup>, and ENT <sup>3,4</sup>

**Footnotes**

- <sup>1</sup> The sprinkler temperature rating is stamped on the deflector.
- <sup>2</sup> Based on NFPA-13. Other limits may apply, depending on fire loading, sprinkler location, and other requirements of the Authority Having Jurisdiction. Refer to specific installation standards.
- <sup>3</sup> Sprinklers with ENT, White Polyester, and Black Polyester finishes are C-UL-US-EU Listed as corrosion resistant.
- <sup>4</sup> The ENT coating has passed the standard corrosion test required by the approving agencies indicated in the Approval Chart. These tests cannot and do not represent all possible corrosive environments. Prior to installation, verify through the end-user that the coatings are compatible with or suitable for the proposed environment. For ENT coated sprinklers, the waterway is coated. Note that the spring is exposed on sprinklers with ENT coating.

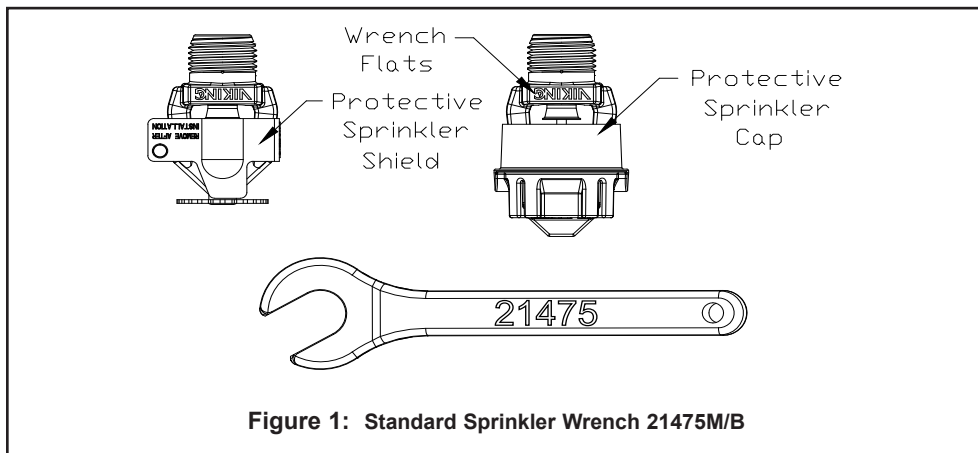

**Figure 1: Standard Sprinkler Wrench 21475M/B**



## TECHNICAL DATA

## FREEDOM® RESIDENTIAL PENDENT SPRINKLER VK468 (K4.9)

The Viking Corporation, 210 N Industrial Park Drive, Hastings MI 49058  
 Telephone: 269-945-9501 Technical Services: 877-384-5464 Fax: 269-818-1680 Email: techsvcs@vikingcorp.com  
 Visit the Viking website for the latest edition of this technical data page www.vikinggroupinc.com

### Approval Chart Viking VK468, 4.9 K-Factor Residential Pendent Sprinkler

For systems designed to NFPA 13D or NFPA 13R. For systems designed to NFPA 13, refer to the design criteria. For Ceiling types refer to current editions of NFPA 13, 13R or 13D

Sprinkler Base Part Number <sup>1</sup>	SIN	NPT Thread Size		Nominal K-Factor		Maximum Water Working Pressure	Overall Length				
		Inches	mm	U.S.	metric <sup>2</sup>		Inches	mm			
13637	VK468	1/2	15	4.9	70.6	175 psi (12 bar)	2-1/4	58			
Max. Coverage Area <sup>4</sup> Ft.X Ft. (m X m)	Ordinary Temp Rating (155 °F/68 °C)		Intermediate Temp Rating (175 °F/79 °C)		Deflector to Ceiling	Installation Type	Listings and Approvals <sup>3</sup>				Minimum Spacing Ft. (m)
	Flow <sup>4</sup> GPM (L/min)	Pressure <sup>4</sup> PSI (bar)	Flow <sup>4</sup> GPM (L/min)	Pressure <sup>4</sup> PSI (bar)			C-UL-US-EU <sup>5</sup>	VdS	NYC <sup>6</sup>	NSF <sup>8</sup>	
12 X 12 (3.7 X 3.7)	13 (49.2)	7.0 (0.48)	13 (49.2)	7.0 (0.48)	1-1/8 to 2 inch	Standard surface-mounted escutcheons, or recessed with the Micromatic® Model E-1, E-2, or E-3 Recessed Escutcheon	See Foot-notes 7 and 10.	See Foot-notes 7 and 10.	See Foot-note 7.	See Foot-note 7.	8 (2.4)
14 X 14 (4.3 X 4.3)	13 (49.2)	7.0 (0.48)	13 (49.2)	7.0 (0.48)							
16 X 16 (4.9 X 4.9)	13 (49.2)	7.0 (0.48)	13 (49.2)	7.0 (0.48)							
18 X 18 (5.5 X 5.5)	17 (64.4)	12.0 (0.83)	17 (64.4)	12.0 (0.83)							
20 X 20 (6.1 X 6.1)	20 (75.7)	16.7 (1.15)	20 (75.7)	16.7 (1.15)							

#### Footnotes

- <sup>1</sup> Part number shown is the base part number. For complete part number, refer to Viking's current price schedule.
- <sup>2</sup> Metric K-factor measurement shown is when pressure is measured in Bar. When pressure is measured in kPa, divide the metric K-factor shown by 10.0.
- <sup>3</sup> This chart shows the listings and approvals available at the time of printing. Other approvals may be in process. Check with the manufacturer for any additional approvals. Refer also to Design Criteria.
- <sup>4</sup> For areas of coverage smaller than shown, use the "Flow" and "Pressure" for the next larger area listed. Flows and pressures listed are per sprinkler. The distance from sprinklers to walls shall not exceed one-half the sprinkler spacing indicated for the minimum "Flow" and "Pressure" used.
- <sup>5</sup> Listed by Underwriter's Laboratories, Inc. for use in the U.S., Canada, and European Union.
- <sup>6</sup> Accepted for use, City of New York Department of Buildings, MEA Number 89-92-E, Vol. 35.
- <sup>7</sup> Approved Finishes are: Brass, Chrome, White Polyester, and Black Polyester<sup>9</sup>
- <sup>8</sup> UL Classified to: NSF/ANSI Standard 61, Drinking Water System Components (MH48034).
- <sup>9</sup> Other paint colors are available on request with the same C-UL-US-EU listings as the standard finish colors.
- <sup>10</sup> Approved finish is Electroless Nickel PTFE (ENT). Sprinklers with ENT, White Polyester, and Black Polyester finishes are C-UL-US-EU Listed as corrosion resistant. ENT is available with standard surface-mounted escutcheons or the Micromatic Model E-1 Recessed Escutcheon.



TECHNICAL DATA

FREEDOM® RESIDENTIAL  
PENDENT SPRINKLER  
VK468 (K4.9)

The Viking Corporation, 210 N Industrial Park Drive, Hastings MI 49058  
 Telephone: 269-945-9501 Technical Services: 877-384-5464 Fax: 269-818-1680 Email: techsvcs@vikingcorp.com  
 Visit the Viking website for the latest edition of this technical data page www.vikinggroupinc.com

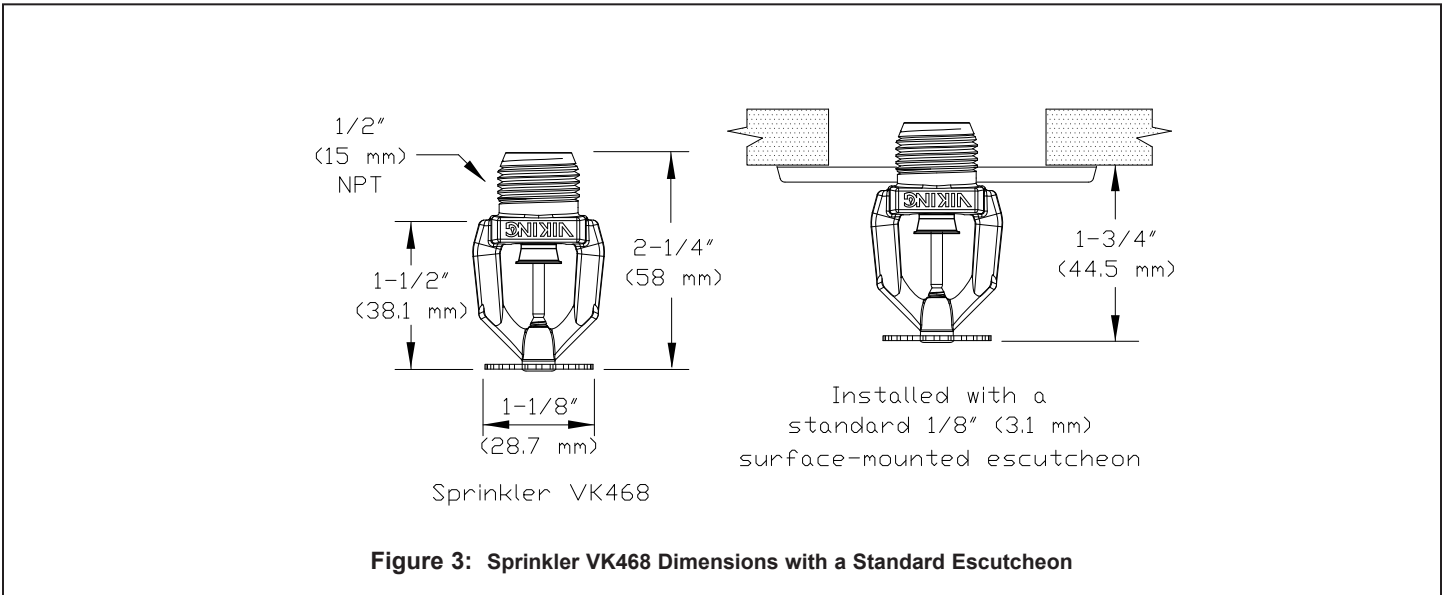
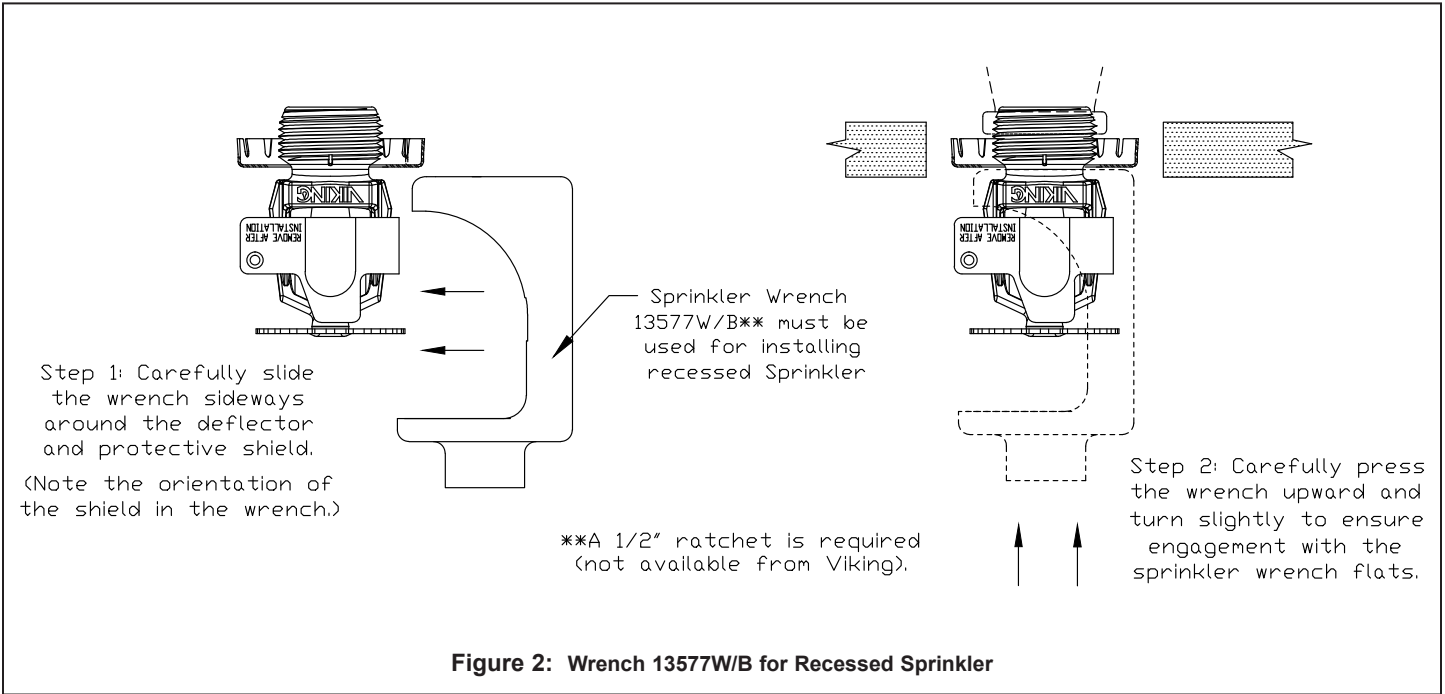



## TECHNICAL DATA

## FREEDOM® RESIDENTIAL PENDENT SPRINKLER VK468 (K4.9)

The Viking Corporation, 210 N Industrial Park Drive, Hastings MI 49058

Telephone: 269-945-9501 Technical Services: 877-384-5464 Fax: 269-818-1680 Email: techsvcs@vikingcorp.com

Visit the Viking website for the latest edition of this technical data page [www.vikinggroupinc.com](http://www.vikinggroupinc.com)

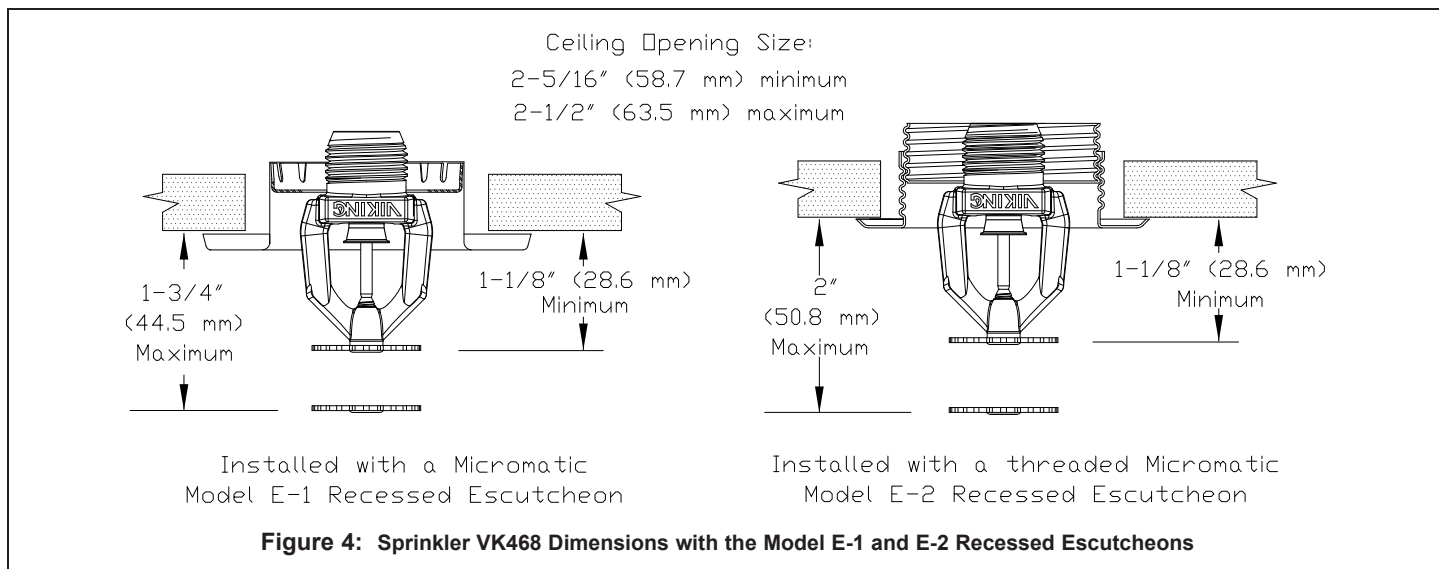

### DESIGN CRITERIA

(Also refer to the Approval Chart.)

#### UL Listing Requirements (C-UL-US-EU):

When using Viking Residential Pendant Sprinkler VK468 for systems designed to NFPA 13D or NFPA 13R, apply the listed areas of coverage and minimum water supply requirements shown in the Approval Chart.

For systems designed to NFPA 13: The number of design sprinklers is to be the four contiguous most hydraulically demanding sprinklers. The minimum required discharge from each of the four sprinklers is to be the greater of the following:

- The flow rates given in the Approval Chart for NFPA 13D and NFPA13R applications for each listed area of coverage, **or**
- Calculated based on a minimum discharge of 0.1 gpm/sq. ft. over the "design area" in accordance with sections 8.5.2.1 or 8.6.2.1.2 of NFPA 13.
- Minimum distance between residential sprinklers: 8 ft. (2.4 m).

**IMPORTANT: Always refer to Bulletin Form No. F\_091699 - Care and Handling of Sprinklers. Also refer to Form No. F\_080614, F\_080415 and F\_080190 for general care, installation, and maintenance information. Viking sprinklers are to be installed in accordance with the latest edition of Viking technical data, the appropriate standards of NFPA, VdS, and any other similar Authorities Having Jurisdiction, and also with the provisions of governmental codes, ordinances, and standards, whenever applicable. Final approval and acceptance of all residential sprinkler installations must be obtained from the Authorities Having Jurisdiction.**



# Viking Residential Sprinkler Installation Guide

**October 25, 2018**

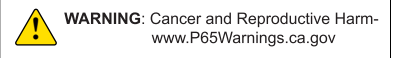

Trusted Above All™

[www.vikinggroupinc.com](http://www.vikinggroupinc.com)



## TECHNICAL DATA

## FREEDOM® RESIDENTIAL SPRINKLER INSTALLATION GUIDE

The Viking Corporation, 210 N Industrial Park Drive, Hastings MI 49058

Telephone: 269-945-9501 Technical Services: 877-384-5464 Fax: 269-818-1680 Email: techsvcs@vikingcorp.com

### 1. DESCRIPTION

Viking residential automatic sprinklers are equipped with a “fast response” heat-sensitive operating element designed to respond individually and quickly to a specific high temperature. Viking residential sprinklers are designed to combine speed of operation with water distribution characteristics to help in the control of residential fires and to improve life safety by prolonging the time available for occupants to escape or be evacuated.

### 2. LISTINGS AND APPROVALS

Refer to the Approval Charts on the appropriate sprinkler technical data page(s) and/or approval agency listings.

- A. Viking residential sprinklers are intended for use in the following occupancies: one- and two-family dwellings and mobile homes with the fire protection sprinkler system installed in accordance with NFPA 13D; residential occupancies up to four stories in height with the fire protection system installed in accordance with NFPA 13R; or residential portions of any occupancy with the fire protection system installed in accordance with NFPA 13. Information contained in this guide is based on NFPA 13, “Standard for the Installation of Sprinkler Systems”.
- B. The design criteria for residential sprinklers contained in the NFPA installation standards must be followed except as modified by the individual UL 1626 listing information provided in the technical data pages and this Residential Sprinkler Installation Guide. For listed areas of coverage, technical data, and specific design and installation instructions, refer to the appropriate Viking technical data page for the sprinkler model used.
- C. Viking residential sprinklers listed by Underwriters Laboratories, Inc. (UL) have passed fire tests designed to represent fire conditions for the sprinkler’s listed area of coverage. The standards for residential sprinkler performance and spray patterns are printed in Underwriters Laboratories Publication UL 1626, “Standard for Residential Sprinklers for Fire Protection Service”. All listed Viking residential sprinklers meet or exceed UL 1626 performance requirements and spray pattern criteria for their listed areas of coverage.
- D. NFPA standards allow use of residential sprinklers with rates, design areas, areas of coverage, and minimum design pressures other than those specified in the standards when they have been listed for such specific residential installation conditions.

### 3. TECHNICAL DATA

#### Specifications:

Refer to the appropriate sprinkler technical data sheet.

#### Material Standards:

Refer to the appropriate sprinkler technical data sheet.

Viking Technical Data may be found on  
The Viking Corporation’s Web site at  
<http://www.vikinggroupinc.com>.  
The Web site may include a more recent  
edition of this Technical Data Page.

### 4. INSTALLATION

**NOTE: Take care not to over-tighten the sprinkler and/or damage its operating parts!**

**Maximum Torque: 1/2” NPT: 14 ft-lbs. (19.0 N-m)      3/4” NPT: 20 ft-lbs. (27.1 N-m)**

#### A. Care and Handling (also refer to Bulletin - Care and Handling of Sprinklers, Form No. F\_091699.)

Sprinklers must be handled with care and protected from mechanical damage during storage, transport, handling, and after installation.

Store sprinklers in a cool, dry place in their original container.

Use care when locating sprinklers near fixtures that can generate heat.

Never install sprinklers that have been dropped, damaged in any way, or exposed to temperatures exceeding the maximum ambient temperature allowed (refer to Table 1.)

Never install any glass-bulb sprinkler if the bulb is cracked or if there is a loss of liquid from the bulb. A small air bubble should be present in the glass bulb. Any sprinkler with a loss of liquid from the glass bulb or damage to the fusible element should be destroyed immediately. (Note: Installing glass bulb sprinklers in direct sunlight (ultraviolet light) may affect the color of the dye used to color code the bulb. This color change does not affect the integrity of the bulb.)

Viking residential sprinklers are intended for use on wet pipe residential systems only. Adequate heat must be provided for wet-pipe systems. DO NOT use Viking residential sprinklers on dry systems unless specifically allowed by recognized installation standards or the Authority Having Jurisdiction.

**Residential concealed sprinklers must be installed in neutral or negative pressure plenums only!**

Corrosion-resistant sprinklers must be installed when subject to corrosive atmospheres. **NOTE:** Viking residential sprinklers are not intended for use in corrosive environments.





## TECHNICAL DATA

## FREEDOM® RESIDENTIAL SPRINKLER INSTALLATION GUIDE

The Viking Corporation, 210 N Industrial Park Drive, Hastings MI 49058  
 Telephone: 269-945-9501 Technical Services: 877-384-5464 Fax: 269-818-1680 Email: techsvcs@vikingcorp.com

**TABLE 1: RESIDENTIAL SPRINKLER TEMPERATURE RATINGS**

Sprinkler Temperature Classification	Sprinkler Nominal Temperature Rating <sup>1</sup>	Maximum Ambient Ceiling Temperature <sup>3</sup>	Bulb Color
<b>Residential Glass Bulb Style Sprinklers</b>			
Ordinary	155 °F (68 °C)	100 °F (38 °C)	Red
Intermediate	175 °F (79 °C)	150 °F (65 °C)	Yellow
Sprinkler Temperature Classification	Sprinkler Nominal Temperature Rating (Fusing Point) <sup>1</sup>	Maximum Ambient Ceiling Temperature <sup>3</sup>	
<b>Residential Fusible Element Style Sprinklers</b>			
Ordinary	165 °F (74 °C)	100 °F (38 °C)	
Sprinkler Temperature Classification	Sprinkler Nominal Temperature Rating (Fusing Point)	Maximum Ambient Ceiling Temperature <sup>3</sup>	Temperature Identification Stamp
<b>Residential Flush Style Sprinklers</b>			
Ordinary	165 °F (74 °C)	100 °F (38 °C)	On Cover or Sprinkler Inlet (VK476)
Intermediate	220 °F (104 °C)	150 °F (65 °C)	On Cover
Sprinkler Temperature Classification	Sprinkler Nominal Temperature Rating (Fusing Point)	Maximum Ambient Ceiling Temperature <sup>3</sup>	Cover Plate Temperature Rating
<b>Residential Concealed Style Sprinklers</b>			
Ordinary	135 °F (57 °C) <sup>1</sup> , 140 °F (60 °C) <sup>2</sup> , 155 °F (68 °C) <sup>1</sup> , or 165 °F (74 °C) <sup>1</sup>	100 °F (38 °C)	135 °F (57 °C)

### Footnotes

<sup>1</sup> The sprinkler temperature rating is stamped on the deflector or flow shaper.

<sup>2</sup> The temperature rating is stamped on the sprinkler.

<sup>3</sup> Based on NFPA-13. Other limits may apply, depending on fire loading, sprinkler location, and other requirements of the Authority Having Jurisdiction. Refer to specific installation standards.

### B. Installation Instructions

Viking sprinklers are manufactured and tested to meet the rigid requirements of approving agencies. They are designed to be installed in accordance with recognized installation standards NFPA 13, NFPA 13R, and NFPA 13D, and any associated TIAs.

Deviation from the standards or any alteration to the sprinklers or cover plate assemblies after they leave the factory including, but not limited to: painting, plating, coating, or modification, may render the sprinklers inoperative and will automatically nullify the approval and any guarantee made by Viking.

The use of residential sprinklers may be limited due to occupancy and hazard. Residential fire protection systems must be designed and installed only by those who are completely familiar with the appropriate standards and codes, and thoroughly experienced in fire protection design, hydraulic calculations, and sprinkler system installation.

Before installation, be sure to have the appropriate sprinkler model and style, with the correct K-Factor, temperature rating, and response characteristics. Viking residential sprinklers must be installed after the piping is in place to prevent mechanical damage. Keep sprinklers with protective caps or bulb shields contained within the caps or shields during installation and testing, and any time the sprinkler is shipped or handled.

1a. For frame-style sprinklers, install escutcheon (if used), which is designed to thread onto the external threads of the sprinkler\*.

\*Refer to the appropriate sprinkler technical data page to determine approved escutcheons for use with specific sprinkler models.

1b. For flush and concealed style sprinklers: Cut the sprinkler nipple so that the ½" or ¾" (15 mm or 20 mm) NPT\*\* outlet of the reducing coupling is at the desired location and centered in the opening\*\* in the ceiling or wall.

\*\*Size depends on the sprinkler model used. Refer to appropriate sprinkler data page.



## TECHNICAL DATA

## FREEDOM® RESIDENTIAL SPRINKLER INSTALLATION GUIDE

The Viking Corporation, 210 N Industrial Park Drive, Hastings MI 49058

Telephone: 269-945-9501 Technical Services: 877-384-5464 Fax: 269-818-1680 Email: techsvcs@vikingcorp.com

### DESIGN CRITERIA

**For Systems Designed to NFPA 13D or NFPA 13R:** Apply the listed areas of coverage and minimum water supply requirements shown in the approval charts on the residential sprinkler data pages. The sprinkler flow rate is the minimum required discharge from each of the total number of design sprinklers as specified in NFPA 13D or NFPA 13R.

**For Systems Designed to the latest edition of NFPA 13:** The number of design sprinklers is to be the four most hydraulically demanding sprinklers. The minimum required discharge from each of the four sprinklers is to be the greater of the following:

- The flow rates given in the approval charts on the data pages for NFPA 13D and NFPA13R for each area of coverage listed, or
- Calculated based on a minimum discharge of 0.1 gpm/sq. ft. over the “design area” in accordance with sections 8.5.2.1 or 8.6.2.1.2 of NFPA 13. The greatest dimension of the coverage area cannot be any greater than the maximum areas of coverage shown on the data pages.

#### Flow Rates

All residential sprinklers manufactured on or after July 12, 2002 are listed with a single minimum flow rate. Where rooms have more than one sprinkler, multiple-sprinkler calculations are still required, but the first sprinkler and any additional sprinkler or sprinklers must be calculated flowing at identical minimum flow rates, based on the area of sprinkler coverage, using the minimum flow and pressure listed for the sprinkler model used.

Consult the appropriate standards and the Authorities Having Jurisdiction to determine the number of sprinklers to hydraulically calculate to verify adequate water supply for multiple-sprinkler operation.

Operating Pressure: The minimum operating pressure of any sprinkler shall be the minimum operating pressure specified by the listing, or 7 psi (0.5 bar), whichever is greater. The maximum allowable operating pressure is 175 psi (12 bar).

#### Areas of Coverage

If the actual area of coverage is less than the listed area of coverage, use the minimum water supply for the next larger area of coverage listed. DO NOT interpolate. Residential sprinkler systems must be hydraulically calculated according to NFPA standards to verify that the water supply is adequate for proper operation of the sprinklers. Hydraulic calculations are required to verify adequate water supply at the hydraulically most remote single sprinkler when it is operating at the minimum gpm and psi listed for single-sprinkler operation for the sprinkler model used.

Viking residential sprinklers may be listed for more than one area of coverage. Suggested practice in selecting area of coverage is to select the one that can be adequately supplied by the available water supply and still allow for the installation of as few sprinklers in a compartment as possible while observing all guidelines pertaining to obstructions and spacing. This maximizes the use of the available water supply, which is often limited on residential fire protection systems. After selecting an appropriate area of coverage, sprinklers must be spaced according to guidelines set forth in the installation standards.

**Definition of “COMPARTMENT”:** A space completely enclosed by walls and a ceiling. Openings to an adjoining space are allowed, provided the openings have a minimum lintel depth of 8 in. (203.2 mm) from the ceiling.

#### Spacing Guidelines

For guidelines concerning spacing of Viking residential sprinklers near beams, obstructions, heat sources, and sloped ceilings [slopes more than a 2/12 (9.5°) pitch], refer to the Viking residential sprinkler data pages and installation guide, the appropriate NFPA standard, and the Authority Having Jurisdiction. NOTE: Sloped, beamed, and pitched ceilings could require special design features such as larger flow, or a design for more sprinklers to operate in the compartment, or both.

**Distance from Walls:** Install not more than one-half the listed sprinkler spacing nor less than 4” (102 mm) from walls, partitions, or obstructions as defined in the standards.

**Minimum Sprinkler Spacing:** The minimum distance between residential sprinklers to prevent cold soldering (i.e., the spray from one operating sprinkler onto an adjacent sprinkler that could prevent its proper activation) is 8 ft. (2.4 m).

**Maximum Sprinkler Spacing:** Locate adjacent sprinklers no farther apart than the listed spacing.

**Deflector Position:** Install frame style residential *pendent* sprinklers with the deflector between 1” and 4” (25.4 mm to 102 mm) below smooth ceilings, unless the sprinkler data page indicates otherwise. Install pendent sprinklers in the pendent position only, with the deflector oriented parallel with the ceiling or roof.

Refer to the individual listings in the residential sprinkler data pages for horizontal sidewall sprinkler deflector or sprinkler centerline distance below the ceiling. Install horizontal sidewall sprinklers in the horizontal position only below smooth ceilings, with the leading edge of the deflector or element assembly oriented parallel with the ceiling.

**IMPORTANT: Always refer to Bulletin Form No. F\_091699 - Care and Handling of Sprinklers. Also refer to the appropriate sprinkler data page. Viking sprinklers are to be installed in accordance with the latest edition of Viking technical data, the appropriate standards of NFPA and any other similar Authorities Having Jurisdiction, and also with the provisions of governmental codes, ordinances, and standards, whenever applicable. Final approval and acceptance of all residential sprinkler installations must be obtained from the Authorities Having Jurisdiction.**



## TECHNICAL DATA

## FREEDOM® RESIDENTIAL SPRINKLER INSTALLATION GUIDE

The Viking Corporation, 210 N Industrial Park Drive, Hastings MI 49058

Telephone: 269-945-9501 Technical Services: 877-384-5464 Fax: 269-818-1680 Email: techsvcs@vikingcorp.com

2. Apply a small amount of pipe-joint compound or tape to the external threads of the sprinkler only, taking care not to allow a build-up of compound in the sprinkler inlet. **NOTE:** Sprinklers with protective caps or bulb shields must be contained within the caps or shields before applying pipe-joint compound or tape. *Exception: For concealed sprinklers (i.e., VK457, VK458, VK468, VK474, and VK4570) the protective cap is removed for installation.*
3. Care must be taken when installing sprinklers on CPVC and copper piping systems. Never install the sprinkler into the reducing fitting before attaching the reducing fitting to the piping. Sprinklers must be installed on CPVC systems after the reducing fitting has been installed and the primer and/or cement manufacturer's recommended curing time has elapsed. When installing sprinklers on copper piping systems, take care to brush the inside of the sprinkler supply piping and reducing fitting to ensure that no flux accumulates in the sprinkler orifice. Excess flux can cause corrosion and may impair the ability of the sprinkler to operate properly.
4. Refer to the appropriate sprinkler technical data page to determine the correct sprinkler wrench for the model of sprinkler used. DO NOT use the sprinkler deflector or fusible element to start or thread the sprinkler into a fitting.
  - a. Install the sprinkler onto the piping using the special sprinkler wrench only, while taking care not to over-tighten or damage the sprinkler operating parts.
  - b. Thread the flush or concealed sprinkler into the 1/2" or 3/4" (15 mm or 20 mm) NPT\*\* outlet of the coupling by turning it clockwise with the special sprinkler wrench. *NOTE: For flush and concealed sprinklers with protective shells, the internal diameter of the special flush and concealed sprinkler installation wrench is designed for use with the sprinkler contained within the shell. Exception: For concealed sprinklers VK457, VK458, VK468, VK474, and VK4570 the protective cap is removed for installation, and then placed back on the sprinkler temporarily.*
5. After installation, the entire sprinkler system must be tested. The test must be conducted to comply with the installation standards.
  - a. Make sure the sprinkler has been properly tightened. If a thread leak occurs, normally the unit must be removed, new pipe-joint compound or tape applied, and then reinstalled. This is due to the fact that when the joint seal leaks, the sealing compound is washed out of the joint.
  - b. **Remove plastic protective sprinkler caps or bulb shields AFTER the wall or ceiling finish work is completed where the sprinkler is installed and there no longer is a potential for mechanical damage to the sprinkler operating elements.** To remove the bulb shields, simply pull the ends of the shields apart where they are snapped together. To remove caps from frame style sprinklers, turn the caps slightly and pull them off the sprinklers. **SPRINKLER CAPS OR BULB SHIELDS MUST BE REMOVED FROM SPRINKLERS BEFORE PLACING THE SYSTEM IN SERVICE!** Retain a protective cap or shield in the spare sprinkler cabinet.
6. For residential flush sprinklers, the ceiling ring can now be installed onto the sprinkler body. Align the ceiling ring with the sprinkler body and thread on or push it on until the flange touches the ceiling. Note the maximum vertical adjustment is 1/2" (12,7 mm) for sprinkler VK420 and 5/8" for VK476. DO NOT MODIFY THE UNIT. If necessary, re-cut the sprinkler drop nipples as required.
7. For residential concealed sprinklers, the cover plate assembly can now be attached.
  - a. Remove the cover plate assembly from the protective box, taking care not to damage the assembly.
  - b. From below the ceiling, gently place the base of the cover plate assembly over the sprinkler protruding through the opening in the ceiling or wall.
  - c. Carefully push the cover plate assembly onto the sprinkler, using even pressure with the palm of the hand, until the unfinished brass flange of the cover plate base touches the ceiling or wall.
  - d. The maximum adjustment available for residential concealed sprinklers is 1/2" (12.7 mm) [1/4" (6.4 mm) for sprinkler VK480]. DO NOT MODIFY THE UNIT. If necessary, re-cut the sprinkler nipples.

**NOTE:** If it is necessary to remove the entire sprinkler unit, the system must be taken out of service. See Maintenance instructions below and follow all warnings and instructions.

## 5. OPERATION

During fire conditions, the operating element fuses or shatters (depending on the type of sprinkler), releasing the pip cap and sealing assembly. Water flowing through the sprinkler orifice strikes the sprinkler deflector or flow shaper, forming a uniform, high-wall wetting spray pattern to extinguish or control the fire.



## TECHNICAL DATA

## FREEDOM® RESIDENTIAL SPRINKLER INSTALLATION GUIDE

The Viking Corporation, 210 N Industrial Park Drive, Hastings MI 49058

Telephone: 269-945-9501 Technical Services: 877-384-5464 Fax: 269-818-1680 Email: techsvcs@vikingcorp.com

### 6. INSPECTIONS, TESTS AND MAINTENANCE

Refer to NFPA 25 for Inspection, Testing and Maintenance requirements. **NOTICE:** The owner is responsible for having the fire-protection system and devices inspected, tested, and maintained in proper operating condition in accordance with this guide, and applicable NFPA standards. In addition, the Authority Having Jurisdiction may have additional maintenance, testing, and inspection requirements that must be followed.

- A. Sprinklers must be inspected on a regular basis for signs of corrosion, mechanical damage, obstructions, paint, etc. Frequency of the inspections may vary due to corrosive atmospheres, water supplies, and activity around the device.
- B. Sprinklers or cover plate assemblies that have been field painted, caulked, or mechanically damaged must be replaced immediately. Sprinklers showing signs of corrosion shall be tested and/or replaced immediately as required. Installation standards require sprinklers to be tested and, if necessary, replaced immediately after a specified term of service. Refer to NFPA 25 and the Authorities Having Jurisdiction for the specified period of time after which testing and/or replacement of residential sprinklers is required. Never attempt to repair or reassemble a sprinkler. Sprinklers and cover assemblies that have operated cannot be reassembled or re-used, but must be replaced. When replacement is necessary, use only new sprinklers and cover assemblies with identical performance characteristics.
- C. The sprinkler discharge pattern is critical for proper fire protection. Nothing should be hung from, attached to, or otherwise obstruct the discharge pattern of the sprinkler. All obstructions must be immediately removed or, if necessary, additional sprinklers installed.
- D. When replacing existing sprinklers, the system must be removed from service. Refer to the appropriate system description and/or valve instructions. Prior to removing the system from service, notify all Authorities Having Jurisdiction. Consideration should be given to employment of a fire patrol in the effected area.
  1. Remove the system from service, drain all water, and relieve all pressure on the piping.
  - 2a. For frame-style sprinklers, use the special sprinkler wrench and remove the old sprinkler by turning it counterclockwise to unthread it from the piping.
  - 2b. *For residential flush pendent and concealed style sprinklers: Remove the ceiling ring or cover plate assembly before unthreading the sprinkler body from the piping. To remove a ceiling ring, grasp it from below the ceiling and gently turn it counterclockwise. Cover plates can be removed either by gently unthreading them or pulling them off the sprinkler body (depends on the sprinkler model used). After the ceiling ring or cover plate assembly has been removed from the sprinkler, use the sprinkler wrench to unthread the sprinkler from the piping. NOTE: For flush and concealed sprinklers with protective shells, the internal diameter of the special flush and concealed sprinkler installation wrench is designed for use with the sprinkler contained within the shell. Place a plastic protective shell (from the spare sprinkler cabinet) over the sprinkler to be removed and then fit the sprinkler wrench over the shell. Exception: Concealed sprinklers VK457, VK458, VK468, VK474, and VK4570 are removed without the plastic cap.*
  3. Follow instructions in section 4B. Installation Instructions to install the new unit. Be sure the replacement sprinkler is the correct model and style, with the appropriate K-Factor, temperature rating, and response characteristics. A fully stocked sprinkler cabinet should be provided for this purpose. *(For flush or concealed style sprinklers, stock of spare ceiling rings or cover plates should also be available in the spare sprinkler cabinet.)*
  4. Place the system back in service and secure all valves. Check for and repair all leaks.
- E. Sprinkler systems that have been subjected to a fire must be returned to service as soon as possible. The entire system must be inspected for damage, and repaired or replaced as necessary. Sprinklers that have been exposed to corrosive products of combustion or high ambient temperatures, but have not operated, should be replaced. Refer to the Authority Having Jurisdiction for minimum replacement requirements.

### 7. AVAILABILITY

Viking Residential Sprinklers are available through a network of domestic and international distributors. See The Viking Corporation web site for the closest distributor or contact The Viking Corporation.

### 8. GUARANTEE

For details of warranty, refer to Viking's current list price schedule or contact Viking directly.

	<b>TECHNICAL DATA</b>	<b>FREEDOM® RESIDENTIAL SPRINKLER INSTALLATION GUIDE</b>
---	-----------------------	--

The Viking Corporation, 210 N Industrial Park Drive, Hastings MI 49058  
 Telephone: 269-945-9501 Technical Services: 877-384-5464 Fax: 269-818-1680 Email: techsvcs@vikingcorp.com

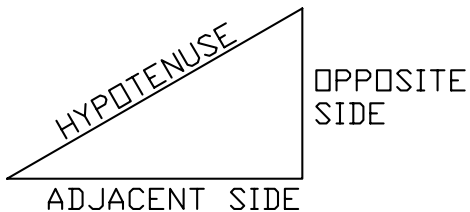

TANGENT =  
 OPPOSITE SIDE (RISE)  
 ADJACENT SIDE (RUN)

$$\frac{\text{RISE}}{\text{RUN}} = \text{TANGENT}$$

$$\text{ANGLE} = \text{TAN}^{-1} \left( \frac{\text{RISE}}{\text{RUN}} \right)$$

$$\text{SLOPE DISTANCE} = \sqrt{\langle \text{RISE} \rangle^2 + \langle \text{RUN} \rangle^2}$$

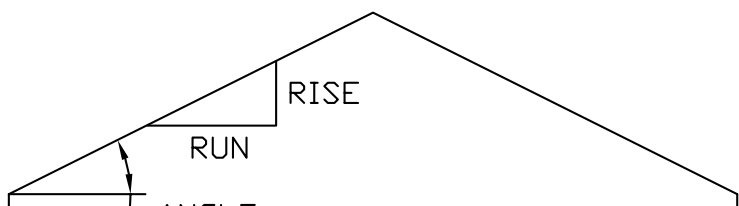

RISE	RUN	TANGENT	ANGLE	SLOPE DISTANCE
2	12	.1666	9.45°	12.1
3	12	.2500	14°	12.3
4	12	.3333	18.4°	12.6
5	12	.4166	22.6°	13
6	12	.5000	26.5°	13.4
7	12	.5833	30.2°	13.8
8	12	.6666	33.6°	14.4
9	12	.7500	36.8°	15
10	12	.8333	39.8°	15.6
11	12	.9166	42.5°	16.2
12	12	1	45°	16.97

**Table 2**  
 Rise Over Run Conversion to Degrees of Slope

	<b>TECHNICAL DATA</b>	<b>FREEDOM® RESIDENTIAL SPRINKLER INSTALLATION GUIDE</b>
---	-----------------------	--

The Viking Corporation, 210 N Industrial Park Drive, Hastings MI 49058  
 Telephone: 269-945-9501 Technical Services: 877-384-5464 Fax: 269-818-1680 Email: techsvcs@vikingcorp.com

**SPACING OF RESIDENTIAL SPRINKLERS LISTED FOR USE  
 BELOW SLOPED CEILINGS UP TO AN 8/12 (33.7°) PITCH**  
 (Refer to the appropriate residential sprinkler technical data page for listings.)

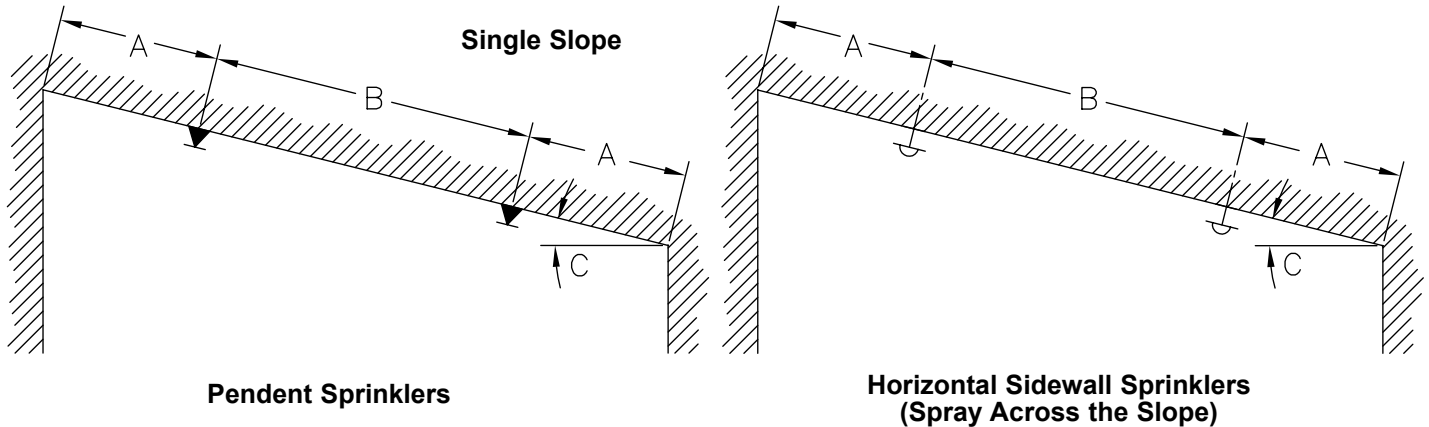

**Figure 1**

- (A) One-half listed spacing of sprinkler maximum, 0'-4" (0-102 mm) minimum.
- (B) Listed spacing of sprinkler, maximum, 8'-0" (2.4 m) minimum.
- (C) Where angle "C" is greater than an 8/12 (33.7°) pitch, see Figure 2 below.

**SPACING OF RESIDENTIAL SPRINKLERS BELOW SLOPED  
 CEILINGS WITH GREATER THAN 8/12 (33.7°) PITCH**  
 (NOTE: Refer to NFPA 13D or NFPA 13R, and the Authority Having Jurisdiction.)

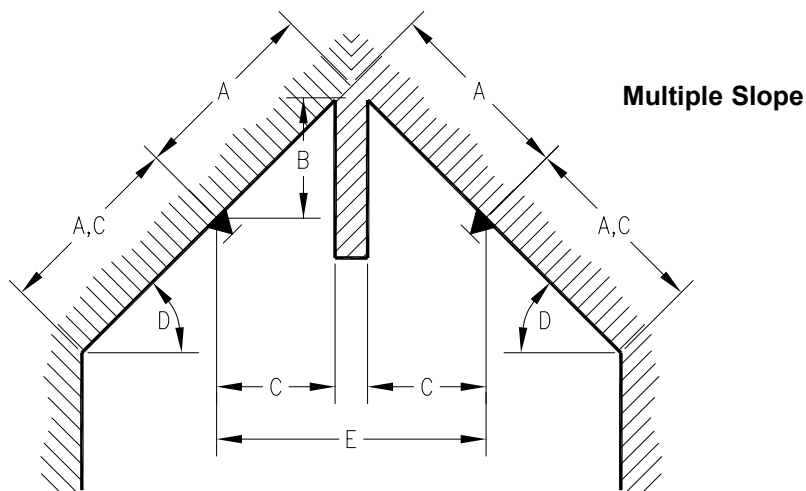

**Figure 2**

- (A) One-half listed spacing of sprinkler, maximum.
- (B) 3'-0" (.91 m) maximum.
- (C) 0'-4" (0-102 mm) minimum.
- (D) Slopes greater than an 8/12 (33.7°) pitch.
- (E) For distance less than 8'-0" (2.4 m), baffle required.



## TECHNICAL DATA

## FREEDOM® RESIDENTIAL SPRINKLER INSTALLATION GUIDE

The Viking Corporation, 210 N Industrial Park Drive, Hastings MI 49058  
 Telephone: 269-945-9501 Technical Services: 877-384-5464 Fax: 269-818-1680 Email: techsvcs@vikingcorp.com

### SPACING OF RESIDENTIAL SPRINKLERS LISTED FOR USE BELOW SLOPED CEILINGS UP TO AN 8/12 (33.7°) PITCH

(Refer to the appropriate residential sprinkler technical data page for listings.)

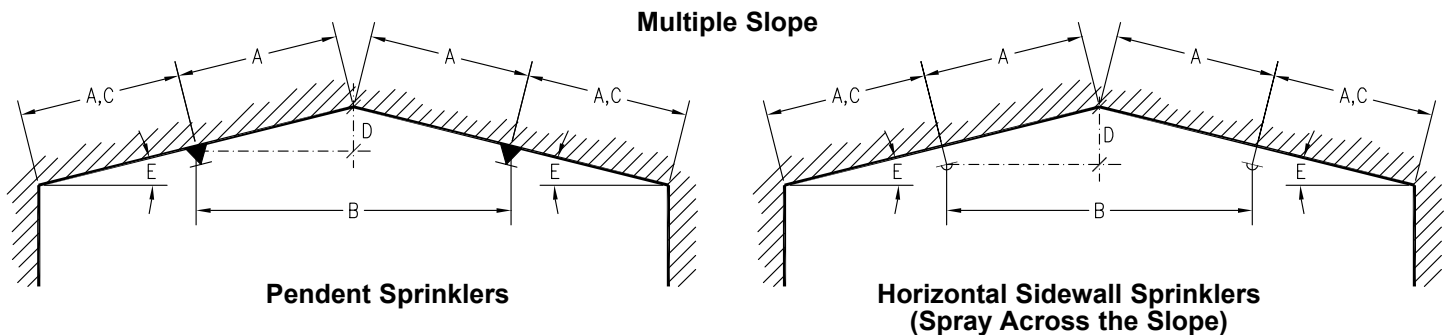
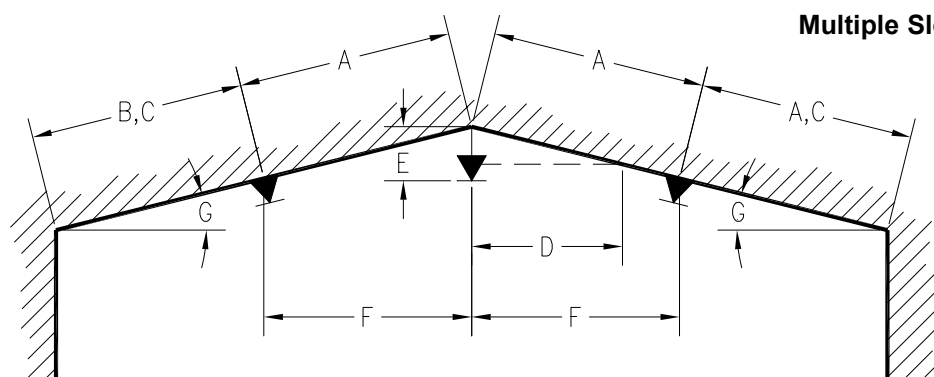

**Figure 3**

- (A) One-half listed spacing of sprinkler, maximum.
- (B) 8'-0" (2.4 m) minimum.
- (C) 0'-4" (0-102 mm) minimum.
- (D) 3'-0" (.91 m) maximum.
- (E) Acceptable for slopes of 0/12 to 8/12 (0° to 33.7°) pitch.

### SPACING OF RESIDENTIAL PENDENT SPRINKLERS AT PEAK OF SLOPED CEILINGS WITH PITCH LESS THAN 8/12 (33.7°)

(Refer to the appropriate residential sprinkler technical data page for listings.)



**Figure 4**

- (A) Listed spacing of sprinkler, maximum.
- (B) One-half listed spacing of sprinkler, maximum.
- (C) 0'-4" minimum.
- (D) Refer to page 10 for minimum distance between sprinkler and intersecting sloped ceiling.
- (E) Refer to the appropriate residential sprinkler technical data page for deflector distance below ceiling.
- (F) 8'-0" minimum.
- (G) Reference: 4/12 (18.0°) pitch maximum for 12' (3.7 m) spacing.  
 2.5/12 (12.0°) pitch maximum for 14' (4.3 m) spacing.  
 2/12 (10.0°) pitch maximum for 16' (4.9 m) spacing.  
 2/12 (10.0°) pitch maximum for 18' (5.5 m) spacing.  
 1.9/12 (9.0°) pitch maximum for 20' (6.1 m) spacing.  
 Angles based on sprinklers installed 0'-4" (0-102 mm) from peak.

**NOTE:** Whenever possible, utilize design as shown in Figure 3 above.



**TECHNICAL DATA**

**FREEDOM® RESIDENTIAL  
SPRINKLER  
INSTALLATION GUIDE**

The Viking Corporation, 210 N Industrial Park Drive, Hastings MI 49058

Telephone: 269-945-9501 Technical Services: 877-384-5464 Fax: 269-818-1680 Email: techsvcs@vikingcorp.com

**SPACING OF RESIDENTIAL SPRINKLERS BELOW SLOPED CEILINGS WITH GREATER THAN 8/12 (33.7°) PITCH WITH NO BAFFLE AND A MAXIMUM OF 2 SPRINKLERS IN THE ROOM**  
(NOTE: Refer to NFPA 13D or NFPA 13R, and the Authority Having Jurisdiction.)

**Multiple Slope**

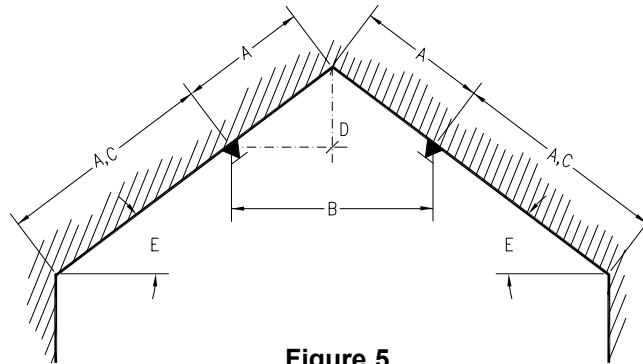
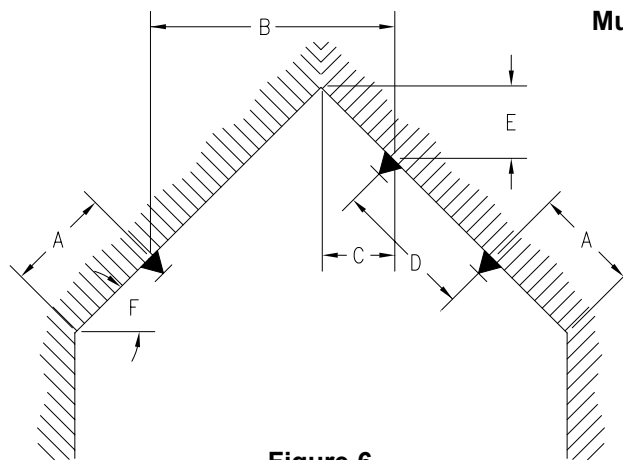

**Figure 5**

- (A) One-half listed spacing of sprinkler, maximum.
- (B) 8'-0" (2.4 m) minimum.
- (C) 0'-4" (0-102 mm) minimum.
- (D) 3'-0" (.91 m) maximum.
- (E) Acceptable for slopes greater than an 8/12 (33.7°) pitch.
- (F) When this design is used, refer to the appendices of NFPA 13D or NFPA 13R, and the Authority Having Jurisdiction regarding the number of design sprinklers to hydraulically calculate.

**SPACING OF RESIDENTIAL SPRINKLERS BELOW CEILINGS WITH SLOPES EXCEEDING 8/12 (33.7°) PITCH WITH NO BAFFLE AND A MAXIMUM OF 3 SPRINKLERS IN THE ROOM**  
(NOTE: Refer to NFPA 13D or NFPA 13R, and the Authority Having Jurisdiction.)

**Multiple Slope**



**Figure 6**

- (A) 0'-4" (0-102 mm) minimum, to one-half listed spacing, maximum.
- (B) One-half listed spacing, maximum, 8'-0" (2.4 m) minimum.
- (C) 0'-4" (0-102 mm) minimum.
- (D) Listed spacing maximum, 8'-0" (2.4 m) minimum.
- (E) 3'-0" (.91 m) maximum.
- (F) Slopes greater than 8/12 up to a 21/12 (33.7° up to 60°) pitch.

**NOTES:** In addition to the above limits, rooms requiring this type of installation must be hydraulically calculated to supply a minimum of three operating sprinklers. Layout similar for horizontal sidewall sprinklers with throw across slope. Refer to the appropriate residential sprinkler technical data sheets.





TECHNICAL DATA

FREEDOM® RESIDENTIAL  
SPRINKLER  
INSTALLATION GUIDE

The Viking Corporation, 210 N Industrial Park Drive, Hastings MI 49058  
Telephone: 269-945-9501 Technical Services: 877-384-5464 Fax: 269-818-1680 Email: techsvcs@vikingcorp.com

**SPACING OF RESIDENTIAL SPRINKLERS BELOW CEILINGS WITH SLOPES EXCEEDING 8/12 (33.7°) PITCH WITH NO BAFFLE AND A MAXIMUM OF 2 SPRINKLERS IN THE ROOM**  
(NOTE: Refer to NFPA 13D or NFPA 13R, and the Authority Having Jurisdiction.)

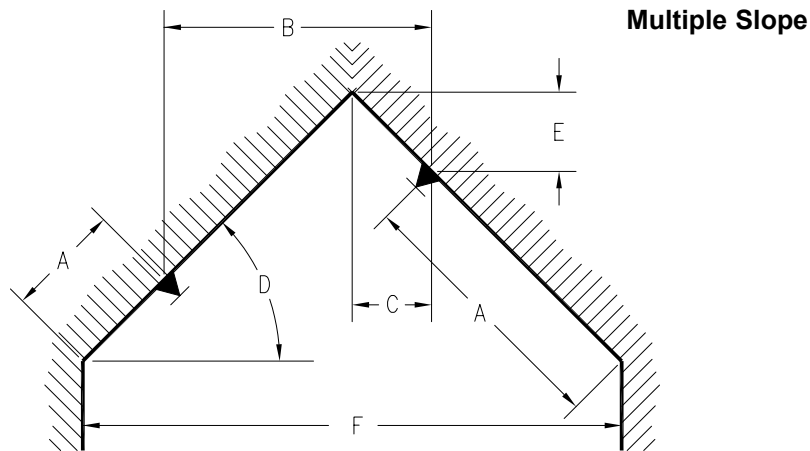

**Figure 7**

- (A) 0'-4" (0-102 mm) minimum, to one-half listed spacing, maximum.
- (B) One-half listed spacing, maximum, 8'-0" (2.4 m) minimum.
- (C) 0'-4" (0-102 mm) minimum.
- (D) Slopes greater than 8/12 pitch up to a 21/12 (33.7° up to a 60°) pitch.
- (E) 3'-0" (.91 m) maximum.
- (F) When dimension "F" exceeds 16' (4.9 m), utilize design configuration shown in Figure 6.

**NOTES:** Layout similar for horizontal sidewall sprinklers with throw across slope. Refer to the appropriate residential sprinkler technical data sheets.

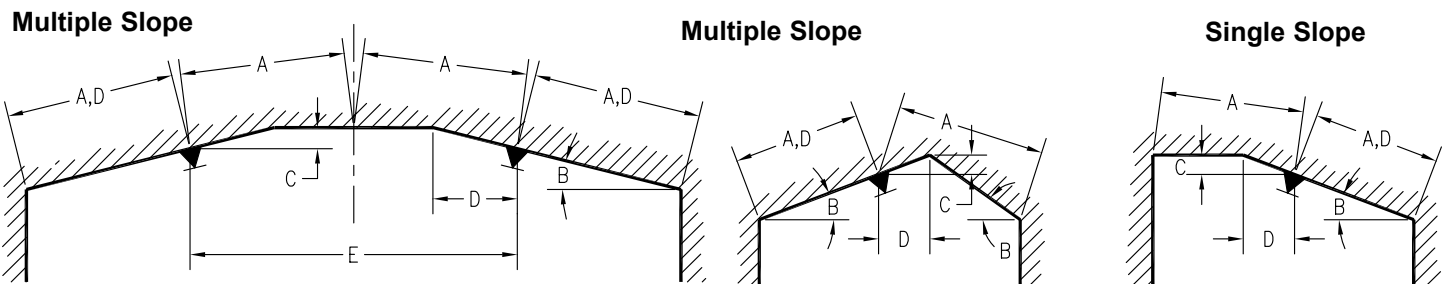

**Figure 8**

- (A) One-half listed spacing, maximum.
- (B) Refer to the appropriate residential sprinkler technical data pages for listings of sprinklers for use below slopes up to and including a 8/12 (33.7°) pitch.
- (C) 3'-0" (.91 m) maximum.
- (D) 0'-4" (0-102 mm) minimum.
- (E) 8'-0" (2.4 m) minimum without baffle.

**NOTES:** Layout similar for horizontal sidewall sprinklers with throw across slope. Refer to the appropriate residential sprinkler technical data sheets.



**TECHNICAL DATA**

**FREEDOM® RESIDENTIAL  
SPRINKLER  
INSTALLATION GUIDE**

The Viking Corporation, 210 N Industrial Park Drive, Hastings MI 49058  
 Telephone: 269-945-9501 Technical Services: 877-384-5464 Fax: 269-818-1680 Email: techsvcs@vikingcorp.com

**MINIMUM DISTANCE BETWEEN SPRINKLER AND INTERSECTING SLOPED CEILINGS**

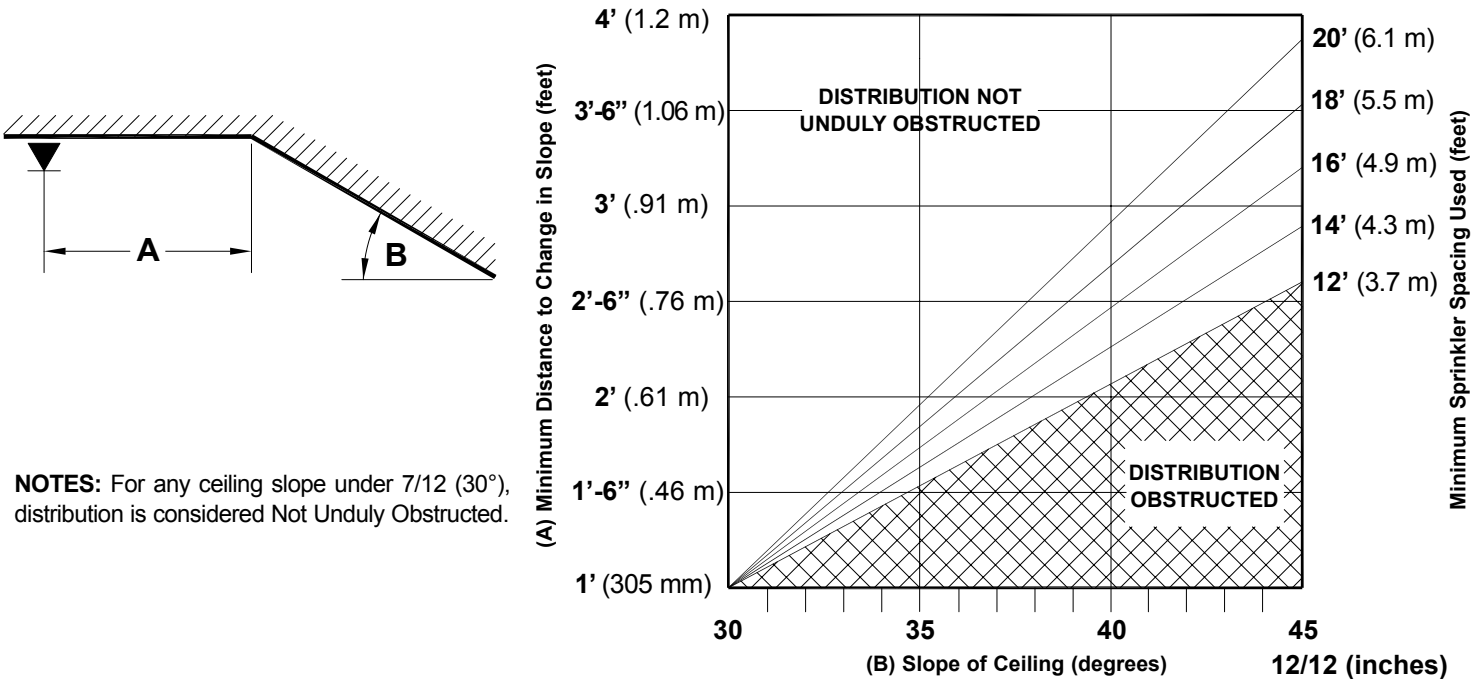

**MAXIMUM DISTANCE DOWN SLOPE TO AVOID OBSTRUCTION TO SPRINKLER DISCHARGE**

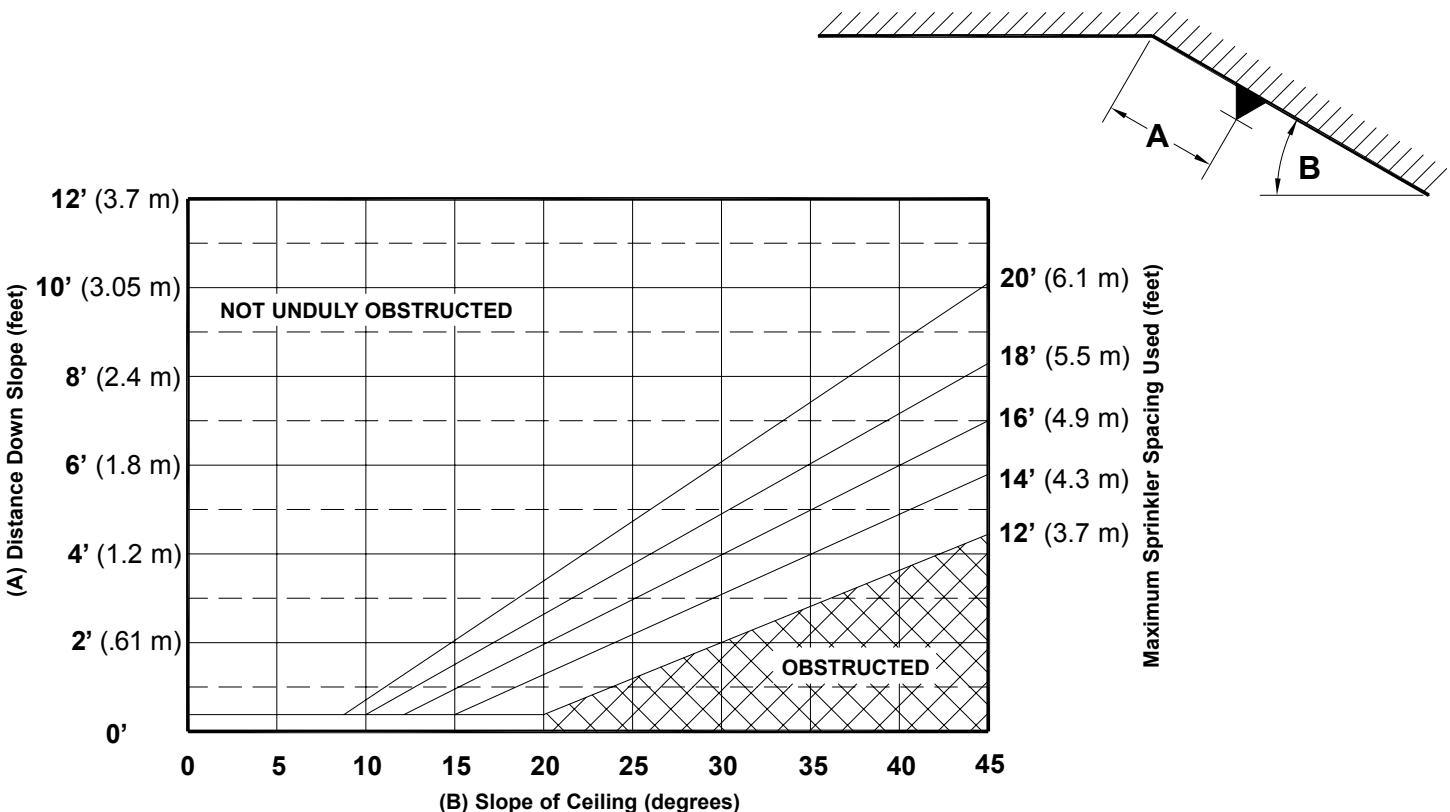



**TECHNICAL DATA**

**FREEDOM® RESIDENTIAL  
SPRINKLER  
INSTALLATION GUIDE**

The Viking Corporation, 210 N Industrial Park Drive, Hastings MI 49058  
 Telephone: 269-945-9501 Technical Services: 877-384-5464 Fax: 269-818-1680 Email: techsvcs@vikingcorp.com

**AVOIDING OBSTRUCTIONS TO SPRINKLER DISCHARGE**

(Obstruction rules for residential sprinklers are found in section 8.10 of the 2010 edition of NFPA 13.)

**Positioning Residential Pendent Sprinklers - Obstructions at the Ceiling**

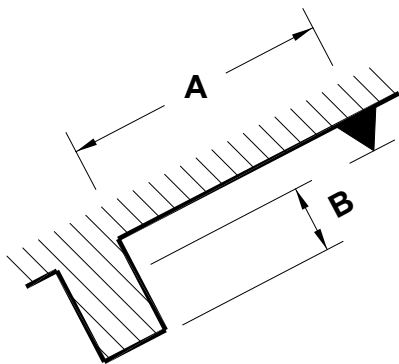
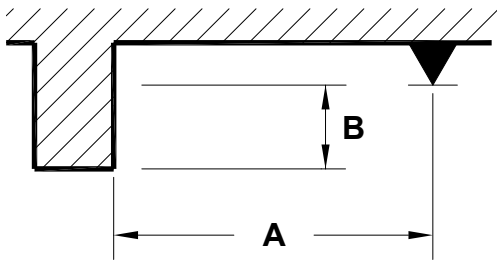

Distance from Sprinkler to Side of Ceiling Obstruction (Dimension A)	Maximum Distance from Deflector to Bottom of Ceiling Obstruction (Dimension B)	
	Inches	mm
Less than 1 ft. 6 in. (Less than 457 mm)	0	0
1 ft. 6 in. to less than 3 ft. (457 mm to less than .94 m)	1	25.4
3 ft. to less than 4 ft. (.91 m to less than 1.2 m)	3	76
4 ft. to less than 4 ft. 6 in. (1.2 m to less than 1.37 m)	5	127
4 ft. 6 in. to less than 6 ft. (1.37 m to less than 1.8 m)	7	178
6 ft. to less than 6 ft. 6 in. (1.8 m to less than 2 m)	9	229
6 ft. 6 in. to less than 7 ft. (2 m to less than 2.1 m)	11	279
7 ft. or greater (2.1 m or greater)	14	356

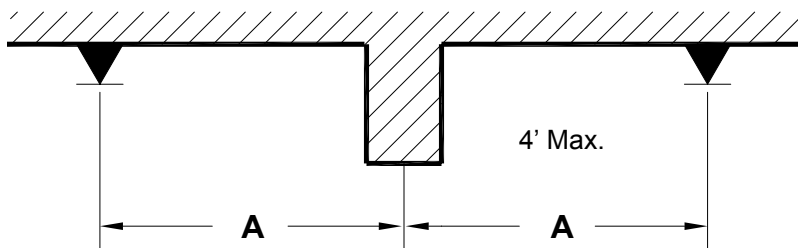

Residential pendent sprinklers may be located on opposite sides of continuous obstructions up to 4 ft. (1.2 m) wide at the ceiling, as long as the distance from the centerline of the obstruction to the sprinklers (A) does not exceed one-half the maximum spacing allowed between sprinklers.

**Positioning Residential Pendent Sprinklers - Obstructions Along Walls**

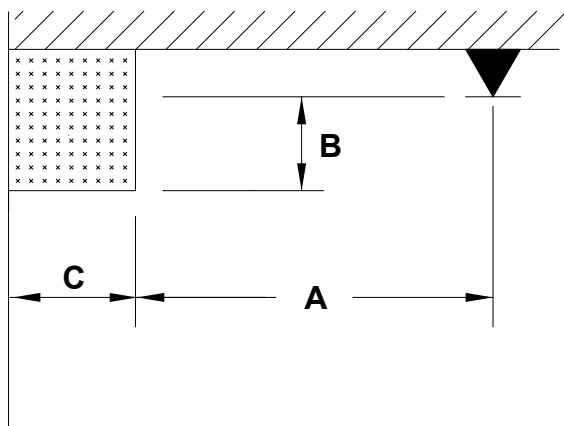

- (A) Distance from centerline of sprinkler to side of obstruction.
- (B) Distance from deflector to bottom of obstruction.
- (C) Width of the obstruction.

Obstructions up to 30 in. (.8 m) wide (C) located against the wall are permitted to be protected when (A) is greater than or equal to (C) minus 8 in. (.2 m) plus (B).

$$C \leq 30 \text{ in.} \quad \text{for metric } C \leq .8 \text{ m}$$

$$A \geq (C - 8 \text{ in.}) + B \quad A \geq (C - .2 \text{ m}) + B$$

	<b>TECHNICAL DATA</b>	<b>FREEDOM® RESIDENTIAL SPRINKLER INSTALLATION GUIDE</b>
---	-----------------------	--

The Viking Corporation, 210 N Industrial Park Drive, Hastings MI 49058  
 Telephone: 269-945-9501 Technical Services: 877-384-5464 Fax: 269-818-1680 Email: techsvcs@vikingcorp.com

**AVOIDING OBSTRUCTIONS TO SPRINKLER DISCHARGE**

(Obstruction rules for residential sprinklers are found in section 8.10 of the 2010 edition of NFPA 13.)

**Positioning Residential Horizontal Sidewall Sprinklers - Obstructions at the Ceiling**

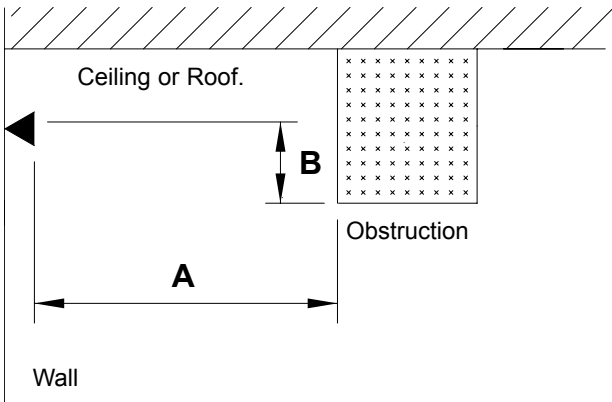

(A) Distance from sprinkler to side of obstruction.  
 (B) Distance from deflector to bottom of obstruction.

Distance from Sprinkler to Side of Ceiling Obstruction (Dimension A)	Maximum Distance from Deflector to Bottom of Ceiling Obstruction (Dimension B)	
	Inches	mm
Less than 8 ft. (Less than 2.4 m)	No Obstructions Allowed	
8 ft. to less than 10 ft. (2.4 m to less than 3.05 m)	1	25.4
10 ft. to less than 11 ft. (3.05 m to less than 3.35 m)	2	50.8
11 ft. to less than 12 ft. (3.35 m to less than 3.7 m)	3	76
12 ft. to less than 13 ft. (3.7 m to less than 4 m)	4	102
13 ft. to less than 14 ft. (4 m to less than 4.3 m)	6	152
14 ft. to less than 15 ft. (4.3 m to less than 4.6 m)	7	178
15 ft. to less than 16 ft. (4.6 m to less than 4.9 m)	9	229
16 ft. to less than 17 ft. (4.9 m to less than 5.2 m)	11	279
17 ft. or greater (5.2 m or greater)	14	356

**Positioning Residential Horizontal Sidewall Sprinklers - Obstructions Along Walls**

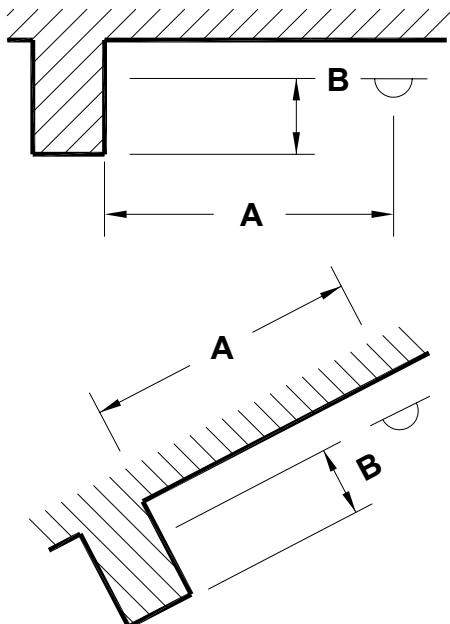

Distance from Sprinkler to Side of Obstruction Along Wall (Dimension A)	Maximum Distance from Deflector to Bottom of Obstruction (Dimension B)	
	Inches	mm
Less than 1 ft. 6 in. (Less than 457 mm)	0	0
1 ft. 6 in. to less than 3 ft. (457 mm to less than .94 m)	1	25.4
3 ft. to less than 4 ft. (.91 m to less than 1.2 m)	3	76
4 ft. to less than 4 ft. 6 in. (1.2 m to less than 1.37 m)	5	127
4 ft. 6 in. to less than 6 ft. (1.37 m to less than 1.8 m)	7	178
6 ft. to less than 6 ft. 6 in. (1.8 m to less than 2 m)	9	229
6 ft. 6 in. to less than 7 ft. (2 m to less than 2.1 m)	11	279
7 ft. or greater (2.1 m or greater)	14	356

(A) Distance from sprinkler to side of obstruction.  
 (B) Distance from deflector to bottom of obstruction.



## TECHNICAL DATA

## FREEDOM® RESIDENTIAL SPRINKLER INSTALLATION GUIDE

The Viking Corporation, 210 N Industrial Park Drive, Hastings MI 49058

Telephone: 269-945-9501 Technical Services: 877-384-5464 Fax: 269-818-1680 Email: techsvcs@vikingcorp.com

### LOCATING RESIDENTIAL SPRINKLERS NEAR HEAT SOURCES

Ordinary temperature rated residential sprinklers (135 °F to 170 °F rated) are only to be installed where the maximum ambient ceiling temperature will not exceed 100 °F. Where the maximum ambient ceiling temperature will be from 101 °F to 150 °F, use intermediate temperature rated residential sprinklers (175 °F to 225 °F rated).

Residential sprinklers must be positioned a sufficient distance away from heat sources that include fireplaces, stoves, kitchen ranges, wall ovens, hot water pipes, water heaters, furnaces and associated flues and ducts, and light fixtures. The following minimum distances must be maintained for both ordinary and intermediate temperature rated residential sprinklers as indicated.

Heat Source	Minimum Distance from Edge of Source to Ordinary Temperature Rated Sprinkler		Minimum Distance from Edge of Source to Intermediate Temperature Rated Sprinkler	
	Inches	metric	Inches	metric
Side of open or recessed fireplace	36	.91 m	12	305 mm
Front of recessed fire place	60	1.5 m	36	.91 m
Coal- or wood-burning stove	42	1.1 m	12	305 mm
Kitchen range	18	457 mm	9	229 mm
Wall oven	18	457 mm	9	229 mm
Hot air flues	18	457 mm	9	229 mm
Uninsulated heat ducts	18	457 mm	9	229 mm
Uninsulated hot water pipes	12	305 mm	6	152 mm
Side of ceiling- or wall-mounted hot air diffusers	24	.61 m	12	305 mm
Front of wall-mounted hot air diffusers	36	.91 m	18	457 mm
Hot water heater or furnace	6	152 mm	3	76 mm
Light fixture less than 250W	6	152 mm	3	76 mm
Light fixture 250W to 499W	12	305 mm	6	152 mm
Where residential sprinklers will be exposed to the rays of the sun passing through glass or plastic skylights, use intermediate temperature rated sprinklers.				
When locating residential sprinklers in an unventilated concealed compartment, under an unventilated attic or uninsulated roof, where the maximum ambient temperature does not exceed 150 °F, use intermediate temperature rated sprinklers.				



**TECHNICAL DATA**

**FREEDOM® RESIDENTIAL  
SPRINKLER  
INSTALLATION GUIDE**

The Viking Corporation, 210 N Industrial Park Drive, Hastings MI 49058

Telephone: 269-945-9501 Technical Services: 877-384-5464 Fax: 269-818-1680 Email: techsvcs@vikingcorp.com

**NOTE:** The dimensions shown are intended to apply to residential sprinklers installed in ceilings above fireplaces used to burn products that cause elevated temperatures at or near the ceiling in areas surrounding the fireplace. The recommendations should not be construed to apply to decorative non-opening fireplaces such as gas fire units that will not cause elevated temperatures at the ceiling.

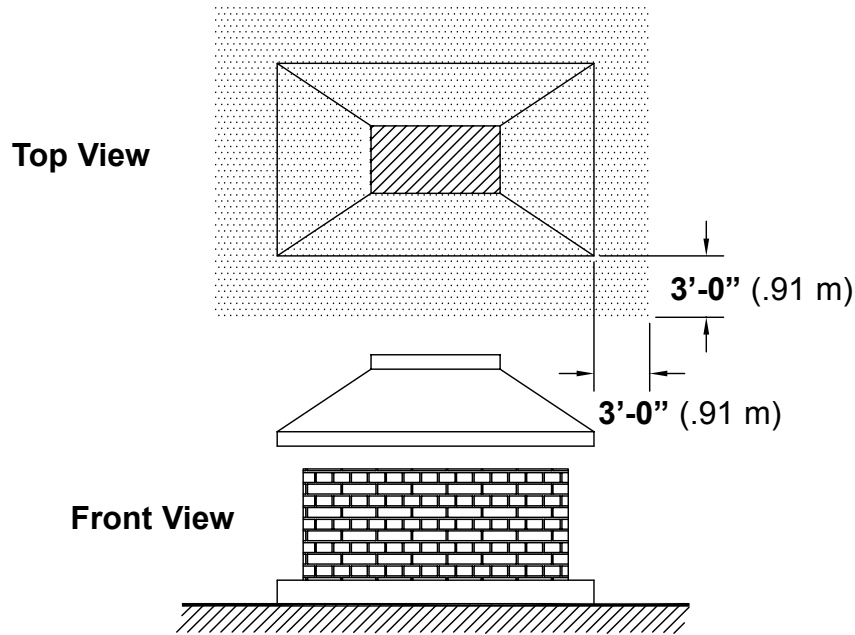

Sprinklers near an open hearth fireplace must be located outside of the shaded area or be intermediate degree rated.

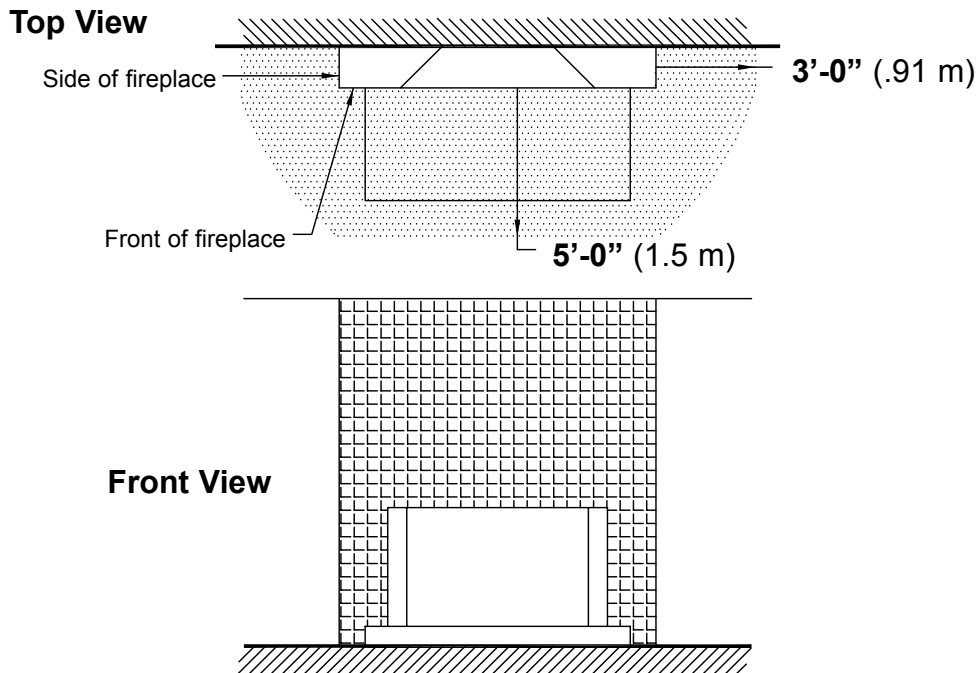

Sprinklers near a recessed hearth fireplace must be located outside of the shaded area [at least 3'-0" (.91 m)] from the side of a recessed fireplace and at least 5'-0" (1.5 m) from the front) or be intermediate degree rated.



**TECHNICAL DATA**

**FREEDOM® RESIDENTIAL  
SPRINKLER  
INSTALLATION GUIDE**

The Viking Corporation, 210 N Industrial Park Drive, Hastings MI 49058  
 Telephone: 269-945-9501 Technical Services: 877-384-5464 Fax: 269-818-1680 Email: techsvcs@vikingcorp.com

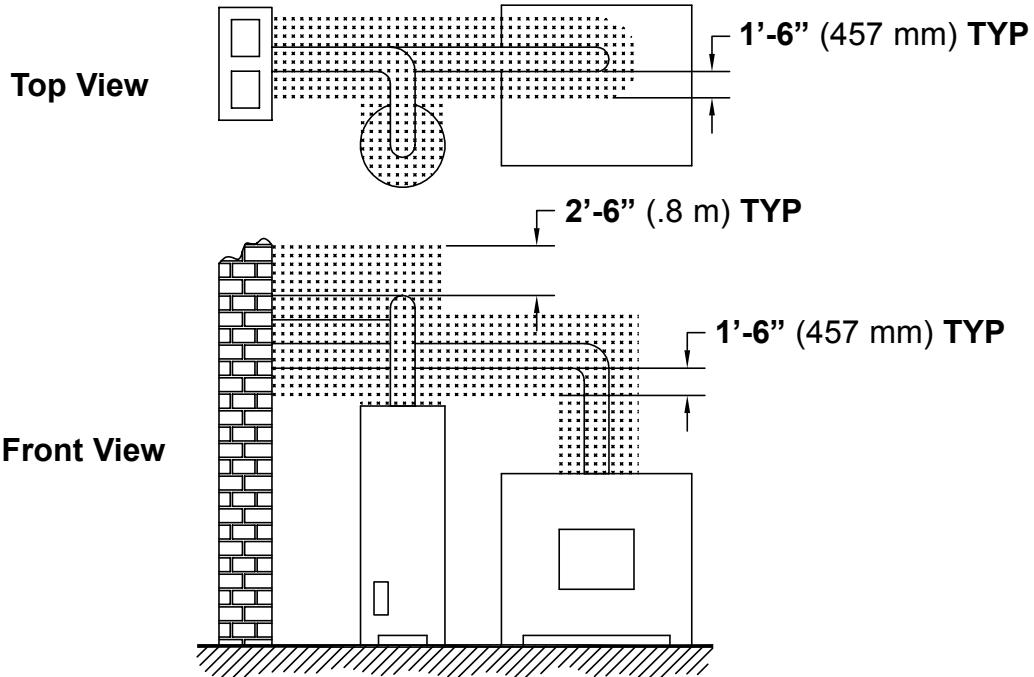

Sprinklers near a furnace or water heater must be located outside of the shaded area or be intermediate degree rated.

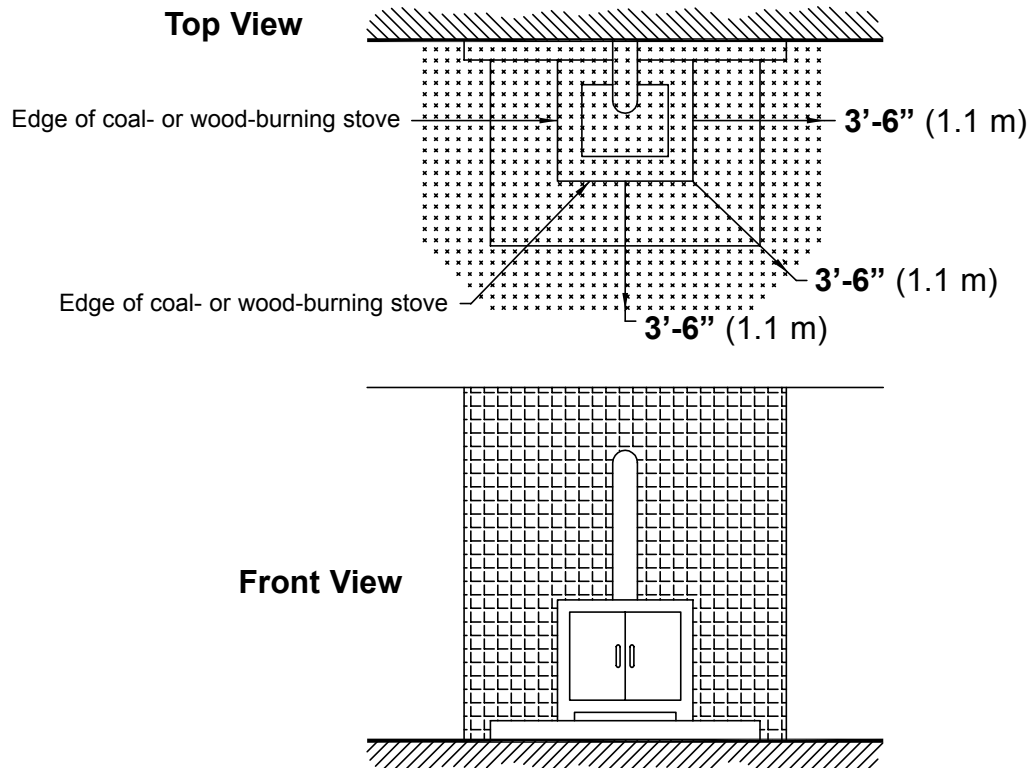

Sprinklers near a coal- or wood-burning stove must be located outside of shaded area or be intermediate degree rated.



TECHNICAL DATA

FREEDOM® RESIDENTIAL  
SPRINKLER  
INSTALLATION GUIDE

The Viking Corporation, 210 N Industrial Park Drive, Hastings MI 49058  
Telephone: 269-945-9501 Technical Services: 877-384-5464 Fax: 269-818-1680 Email: techsvcs@vikingcorp.com

Top View

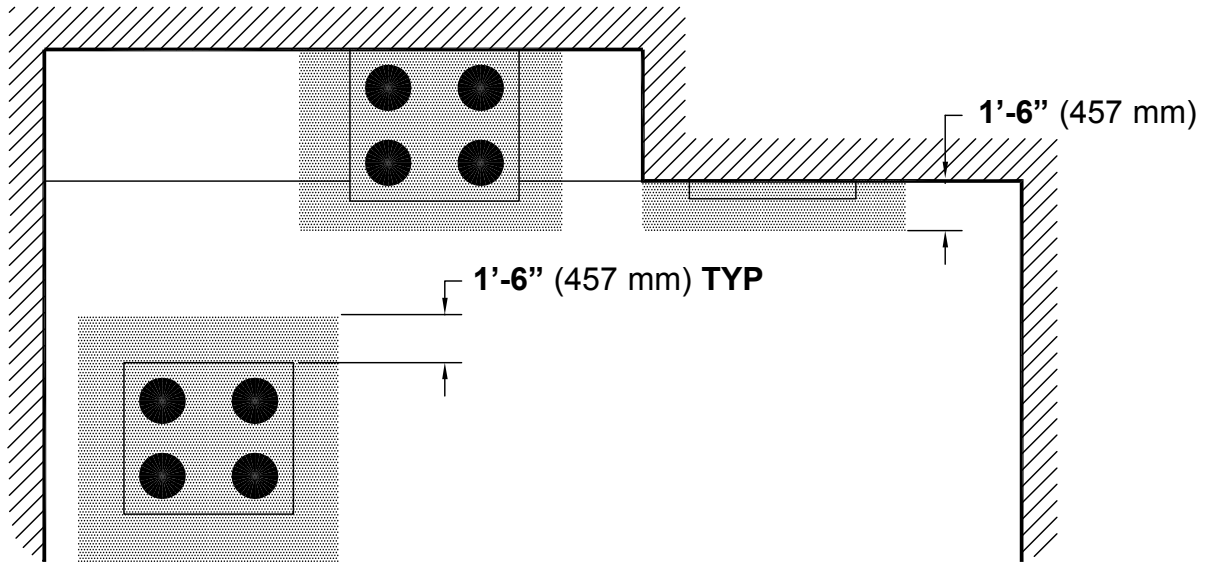

Front View

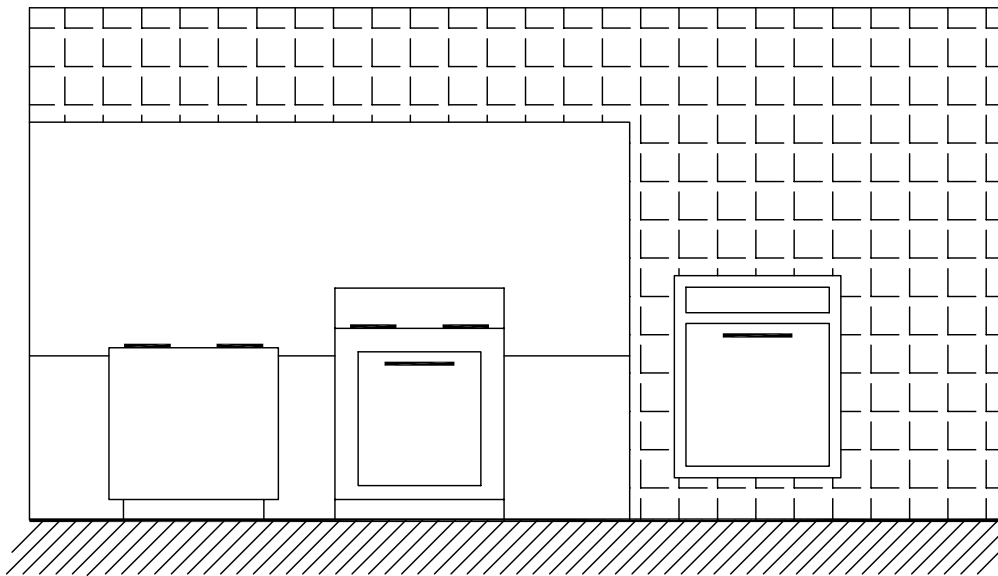

Sprinklers near a range or wall oven must be located outside of shaded areas or be intermediate degree rated.





## TECHNICAL DATA SHEET

### VK3021 Quick Response Pendent Sprinkler K5.6 (80.6)

#### 1. PRODUCT IDENTIFICATION

This document covers the following product, hereafter referred to as “sprinkler”:

VK3021: Quick Response, Standard Coverage, Pendent, K5.6 (80.6) Sprinkler.

#### 2. INTENDED USE

The sprinkler is intended to be used in automatic fire sprinkler systems as allowed by applicable approval authorities. The sprinkler must be used in accordance with:

1. the sprinkler’s Listings, Approvals, and associated design requirements.
2. the recognized design and installations standards issued, for example NFPA, FM, EN, VdS, or LPCB.
3. the latest revisions of all applicable manufacturer’s documentation.

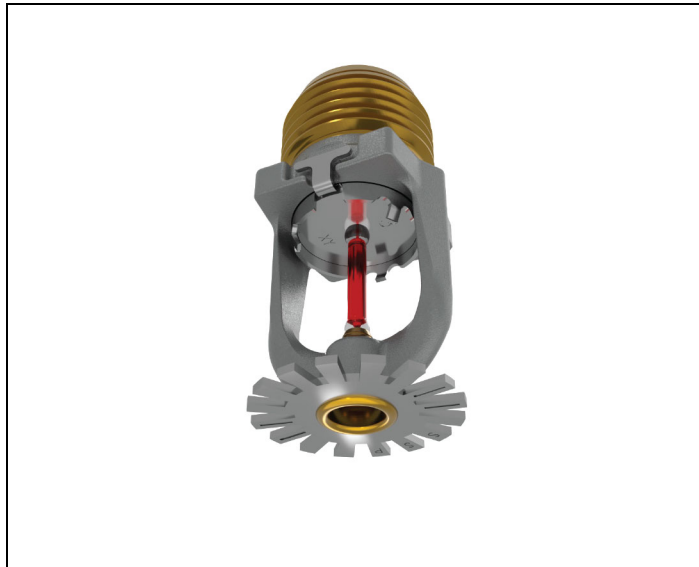

Governmental codes, ordinances, and standards may apply and may differ from one another.

#### **WARNING**

Cancer and Reproductive Harm [www.P65Warnings.ca.gov](http://www.P65Warnings.ca.gov)

#### 3. LISTING AND APPROVALS

Refer to section 5 for details and requirements that must be followed.



cULus Listed



VdS Approved



FM Approved



UKCA Approved



CE



MED Approved



LPCB Approved

**TECHNICAL DATA SHEET**
**VK3021 Quick Response  
Pendent Sprinkler K5.6 (80.6)**
**4. TECHNICAL SPECIFICATIONS**
**4.1 Definitions**

**Standard Pendent Sprinkler:** A sprinkler intended to be oriented with the deflector below the frame so water flows downward through the orifice, striking the deflector and forming an umbrella-shaped spray pattern downward. These sprinklers are marked “SP/RP” (Standard Pendent/Recessed Pendent). When a standard pendent sprinkler is used with a recessed escutcheon, it becomes a recessed pendent sprinkler.

**Recessed Sprinkler:** A spray sprinkler assembly intended for installation with a concealed piping system. The assembly consists of a sprinkler installed in a decorative adjustable recessed escutcheon that minimizes the protrusion of the sprinkler beyond the ceiling or wall without adversely affecting the sprinkler distribution or sensitivity. Refer to the appropriate technical data page for allowable sprinkler models, temperature ratings, and occupancy classifications.

**NOTICE: Do not recess any sprinkler not listed or approved for use with the escutcheon. Refer to Section 5.**

**Corrosion Resistant Sprinkler:** A special service sprinkler with non-corrosive protective coatings, or that is fabricated from non-corrosive material, for use in atmospheres that would normally corrode sprinklers. Sprinklers can be ordered as corrosion resistant sprinklers and can be used with escutcheons when allowed by the approval body.

**4.2 Ratings and Physical Characteristics**

Parameter	Value
Minimum operating pressure	7 psi (0.5 bar)
Maximum rated pressure	UL: 250 psi (17 bar) FM and CE: 175 psi (12 bar)
Factory tested pressure	500 psi (35 bar)
Thread size	1/2" NPT or 15 mm BSPT
Nominal K-factor	5.6 U.S. (80.6)
Minimum temperature rating (glass bulb)	-65 °F (-55 °C)

## 4.3 Markings and Dimensions

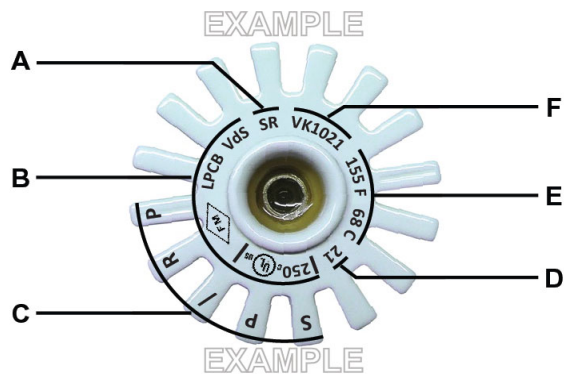

Figure – 1 Markings

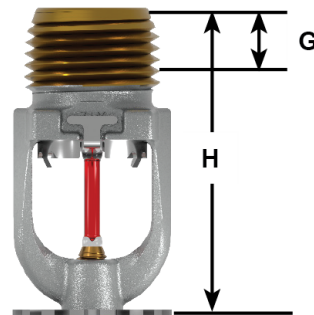

Figure – 2: Dimensions

Ref	Description	Value
A	Response type	QR: Quick Response
B	Listings and Approvals	See sections 3 and 5
C	Sprinkler type	SP/RP: Standard Pendent/Recessed Pendent
D	Manufacture date (year)	See marking
E	Nominal temperature rating	See marking
F	Manufacturers Sprinkler Identification Number (SIN)	VK3021
G	Nominal pipe engagement	7/16" (11 mm)
H	Height	1-15/16" (49 mm)

#### 4.4 Materials of Construction

**NOTICE: Do not disassemble the sprinkler.**

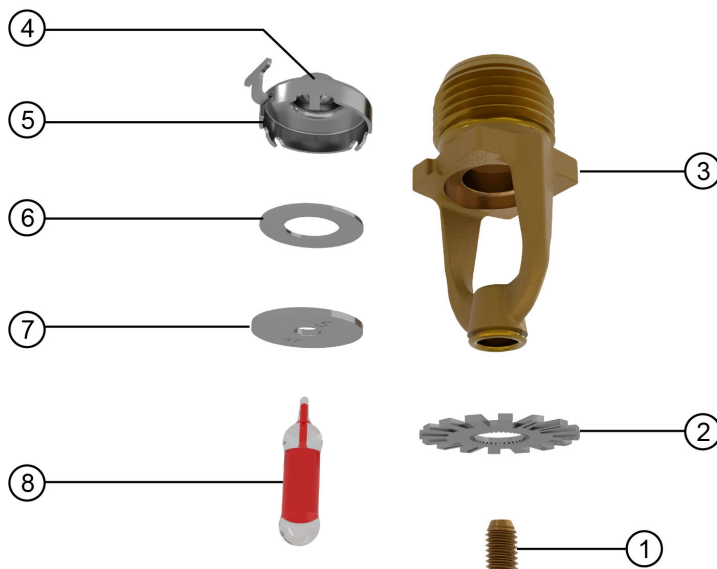

Figure – 3 Sprinkler Components

Ref	Description	Material
1	Compression screw	Brass CW612N, CW508L, UNS-C36000 or UNS-C26000
2	Deflector	Stainless steel UNS S30400
3	Sprinkler body	CW602N, UNS-C84400 or QM brass
4	Pip cap seal	Polytetrafluoroethylene (PTFE)
5	Pip cap shell	Stainless steel UNS-S44400
6	Belleville spring	Nickel alloy
7	Pip cap disc	Stainless steel UNS-S30100
8	Bulb	Glass, nominal 0.10" (3 mm) diameter

**TECHNICAL DATA SHEET**
**VK3021 Quick Response  
Pendent Sprinkler K5.6 (80.6)**
**5. LISTING AND APPROVAL DESIGN REQUIREMENTS**
**5.1 Listing and Approval Specifications**

Sprinkler Base Part Number <sup>1</sup>	Thread Size		Approval Body				
	NPT	BSPT	cULus		FM		
			Approval Specification	Maximum working water pressure	Approval Specification	Maximum working water pressure	
23870	1/2"	—	A1, A2X, A3Y	250 psi (17 bar)	A1, B2X, B3Y	175 psi (12 bar)	
23882	—	15 mm	A1, A2X, A3Y	250 psi (17 bar)	A1, B2X, B3Y	175 psi (12 bar)	
<b>Additional Listings and Approvals Maximum WWP 175 psi (12 bar)</b>							
			CE	LPCB	VdS	UKCA	MED
23870	1/2"	—	A1, B2X, B3Y	A1, A2X, A3Y	A1	A1, A2X, A3Y	A1, A2X, A3Y
23882	—	15 mm	A1, B2X, B3Y	A1, A2X, A3Y	A1	A1, A2X, A3Y	A1, A2X, A3Y
<b>Approval Specification (Temperature Ratings) Key:</b>							
A = 135 °F (57 °C), 155 °F (68 °C), 175 °F (79 °C), 200 °F (93 °C) and 286 °F (141 °C)							
B = 135 °F (57 °C), 155 °F (68 °C), 175 °F (79 °C), and 200 °F (93 °C)							
<b>Approval Specification (Finishes) Key:</b>							
1 = Brass, Chrome, White Polyester <sup>2,3</sup> , Black Polyester <sup>2,3</sup> , and ENT <sup>3,4</sup>							
2 = Brass, Chrome, White Polyester <sup>2,3</sup> , and Black Polyester <sup>2,3</sup>							
3 = ENT <sup>3,4</sup>							
<b>Approval Specification (Escutcheons) Key:</b>							
X = Installed with Viking Recessed Escutcheons Models E-1, E-2, E-3, NP-1, NP-2, and NP-3, or Viking Standard Surface Mounted Escutcheons							
Y = Installed with Viking Recessed Escutcheons Models E-1 and NP-1, or Viking Standard Surface Mounted Escutcheons							
1 For complete part number, refer to Viking's current price list.							
2 For White Polyester and Black Polyester, other colors are available upon request and will carry the same Listings and Approvals as the standard colors.							
3 cULus Listed as corrosion resistant.							
4 FM Approved as corrosion resistant.							

**5.2 cULus Listing Requirements and Details**

The sprinkler is cULus Listed as indicated in Table 5.1 for installation in accordance with the latest edition of NFPA 13 for standard spray sprinklers. This sprinkler is designed for use in light and ordinary hazard occupancies.

**5.3 FM Approval Requirements and Details**

The sprinkler is FM Approved as quick response Non-Storage pendent sprinkler as indicated in the FM Approval Guide. The sprinkler is also approved for use in FM Approved vacuum dry sprinkler systems with a maximum supervisory vacuum pressure of -3 psi (-207 mbar). FM Global Loss Prevention Data Sheets contain guidelines relating to, but not limited to: minimum water supply requirements, hydraulic design, ceiling slope and obstructions, minimum and maximum allowable spacing, and deflector distance below the ceiling. For specific application and installation requirements, refer to the latest applicable FM Loss Prevention Data Sheets (including Data Sheet 2-0).



#### 5.4 Additional Approval Requirements and Details

Refer to Table 5.1 for approved configurations allowed by each of the following approvals.

- CE CPR: Standard EN 12259-1:1999 +A3:2006; Declaration of Performance DOP\_XT1A.
- LPCB: Standard EN 12259-1:1999 +A3:2006; Certificate Number 096m.
- VdS: Standard EN 12259-1:1999 +A3:2006; Certificate Number G 422006.
- UKCA: Standard EN12259-1:1999 +A3:2006; Declaration of Conformity UKCA DOC\_S5048.
- MED: Standard EN 12259-1:1999 +A3:2006; Declaration of Conformity DOC\_MED\_XT1.

For specific application and installation requirements, refer to the latest applicable governmental codes, ordinances, and standards for the installation location.

#### 5.5 Corrosion Resistant Coatings

The corrosion resistant coatings have passed the standard corrosion tests required by the approving agencies and are listed and approved as indicated in Table 5.1. These tests do not represent all possible corrosive environments. The Electro-less Nickel PTFE (ENT) finish passed the UL 199 thirty day corrosion test and is cULus listed and FM Approved as corrosion resistant. For automatic sprinklers, the ENT coating is applied to all exposed exterior surfaces, including the waterway.

Prior to installation, verify that the coatings are compatible with, or suitable for, the proposed environment. The ENT finish has not been evaluated for environments containing chlorine, such as indoor swimming pools. It is not recommended for these applications.

#### 5.6 Sprinkler Guards and Water Shields

The sprinkler is approved for use with the Model XG Sprinkler Guard and the Model F-1 water shield. Refer to the Guards and Water Shields for XT1 Sprinklers technical data sheet for more information.

#### 5.7 Escutcheons

The sprinkler is approved for use with various styles of Viking escutcheons. Specific installation dimensions apply that must be observed. Refer to the sprinkler's Handling and Installation instructions for more information.

#### 5.8 Available Temperature Ratings

Viking sprinklers are available in several temperature ratings that relate to a specific temperature classification. Applicable installation rules mandate the use and limitations of each temperature classification. In selecting the appropriate temperature classification, the maximum expected ceiling temperature must be known. When there is doubt as to the maximum temperature at the sprinkler location, a maximum-reading thermometer should be used to determine the temperature under conditions that would show the highest readings to be expected. In addition, recognized installation rules may require a higher temperature classification, depending upon sprinkler location, occupancy classification, commodity classification, storage height, and other hazards. In all cases, the maximum expected ceiling temperature dictates the lowest allowable temperature classification. Sprinklers located immediately adjacent to a heat source may require a higher temperature rating.

**TECHNICAL DATA SHEET**
**VK3021 Quick Response  
Pendent Sprinkler K5.6 (80.6)**
**6. ORDERING PROCEDURE**
**6.1 Sprinkler**

1. Choose a sprinkler base part number with the required thread size and listing or approval (refer to section 5):
2. Add the suffix for the desired finish.
3. Add the suffix for the desired temperature rating.

**NOTE: For Polyester, insert the desired temperature rating suffix where the dash (-) is shown.**

**EXAMPLE: 23870MB/W** = VK3021 with white polyester finish and 155 °F (68 °C) nominal temperature rating. This sprinkler is to be installed into an area with a maximum ambient temperature of 100 °F (38 °C).

1. Sprinkler Base Part Number		2. Finish		3. Temperature Rating			
See Section 5		Description	Suffix	Nominal Temperature Rating	Bulb Color	Maximum Ambient Ceiling Temperature	Suffix
23870	1/2" NPT	Brass	A	135 °F (57 °C)	Orange	100 °F (38 °C)	A
23882	15 mm BSPT	Chrome	F	155 °F (68 °C)	Red	100 °F (38 °C)	B
		White Polyester	M-/W	175 °F (79 °C)	Yellow	150 °F (65 °C)	D
		Black Polyester	M-/B	200 °F (93 °C)	Green	150 °F (65 °C)	E
		ENT	JN	286 °F (141 °C)	Blue	225 °F (107 °C)	G
				OPEN	—	—	Z

## 6.2 Sprinkler Accessories



Figure – 4: Sprinkler Accessories

Image Reference	Part Number	Description
1)	23559MB	Straight wrench: required for proper installation
2)	23560MB	Recessed socket wrench
3)	01724A	Sprinkler cabinet: holds up to 6 sprinklers
4)	01725A	Sprinkler cabinet: holds up to 12 sprinklers (not shown)
5)	06419A	Model E-1 Slip-on style recessed escutcheon
	07902	Model E-1 Slip-on style recessed escutcheon (stainless steel)
6)	11038	Model E-2 Threaded recessed escutcheon
7)	18347	Model E-3 Threaded recessed escutcheon (large diameter outer cup)
8)	01960A	Large standard flat surface mount escutcheon (steel)
	09488	Large standard flat surface mount escutcheon (stainless steel)
9)	02960A	Small standard flat surface mount escutcheon (steel)
	07526	Small standard flat surface mount escutcheon (stainless steel)
10)	01961B	Large standard raised surface mount escutcheon (brass)



**TECHNICAL DATA SHEET**
**VK3021 Quick Response  
Pendent Sprinkler K5.6 (80.6)**
**7. CONTACT**

The sprinkler and accessories are available through Viking distributors only. Contact your local Viking sales office which can be found on our website:

Americas and Asia: [www.vikinggroupinc.com/locations](http://www.vikinggroupinc.com/locations) OR Europe, Middle East, Africa (EMEA): [www.viking-emea.com/contact](http://www.viking-emea.com/contact)

**Manufacturer:**

The Viking Corporation  
5150 Beltway SE  
Caledonia, MI 49316  
Tel.: (800) 968-9501  
Fax: 269-818-1680  
Technical Services: 1-877-384-5464  
[techsvcs@vikingcorp.com](mailto:techsvcs@vikingcorp.com)

**Importer EU:**

Viking S.A.  
21, Z.I, Haneboesch  
L-4562 Differdange / Niederkorn  
Tel.: +352 58 37 37 – 1  
Fax: +352 58 37 36  
[vikinglux@viking-emea.com](mailto:vikinglux@viking-emea.com)

**Asia Pacific (APAC) Main Office:**

The Viking Corporation (Far East) Pte. Ltd.  
69 Tuas View Square  
Westlink Techpark, Singapore 637621  
Tel: (+65) 6 278 4061  
Fax: (+65) 6 278 4609  
[vikingAPAC@vikingcorp.com](mailto:vikingAPAC@vikingcorp.com)



## TECHNICAL DATA

## FREEDOM® RESIDENTIAL HORIZONTAL SIDEWALL SPRINKLER VK484 (K4.2)

The Viking Corporation, 210 N Industrial Park Drive, Hastings MI 49058

Telephone: 269-945-9501 Technical Services: 877-384-5464 Fax: 269-818-1680 Email: techsvcs@vikingcorp.com

Visit the Viking website for the latest edition of this technical data page [www.vikinggroupinc.com](http://www.vikinggroupinc.com)

### 1. DESCRIPTION

Viking Freedom® Residential Horizontal Sidewall Sprinkler VK484 is a small, thermosensitive, glass-bulb residential sprinkler available in several different finishes and temperature ratings to meet varying design requirements. The Electroless Nickel PTFE (ENT) coating has been investigated for installation in corrosive atmospheres and is cULus Listed as corrosion resistant as indicated in the Approval Chart. The sprinkler orifice design, with a K-factor of 4.2, allows efficient use of available water supplies for the hydraulically designed fire-protection system. The glass bulb operating element and special deflector characteristics meet the challenges of residential sprinkler standards.

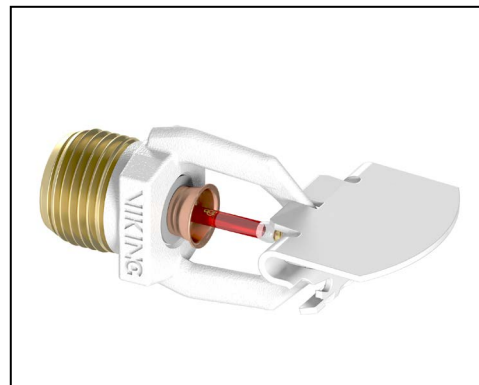

**WARNING:** Cancer and Reproductive Harm-  
[www.P65Warnings.ca.gov](http://www.P65Warnings.ca.gov)

### 2. LISTINGS AND APPROVALS

 **UL Listed (C-UL-US-EU)** Category VKKW

Refer to the Approval Chart and Design Criteria for cULus Listing requirements that must be followed.

### 3. TECHNICAL DATA

#### Specifications:

Available since 2011.

Minimum Operating Pressure: Refer to the Approval Chart.

Maximum Working Pressure: 175 psi (12 bar). Factory tested hydrostatically to 500 psi (34.5 bar).

Thread size: 1/2" (15 mm) NPT

Nominal K-Factor: 4.2 U.S. (57 metric†)

† Metric K-factor measurement shown is in Bar. When pressure is measured in kPa, divide the metric K-factor shown by 10.0.

Glass-bulb fluid temperature rated to -65 °F (-55 °C)

Overall Length: 3" (76 mm)

#### Material Standards:

Frame Casting: QM Brass

Deflector: Brass UNS-C23000

Bulb: Glass, nominal 3 mm diameter

Belleville Spring Sealing Assembly: Nickel Alloy, coated on both sides with Polytetrafluoroethylene (PTFE)

Compression Screw: Brass UNS-C36000

Pip Cap and Insert Assembly: Copper UNS-C11000 and Stainless Steel UNS-S30400

Pip Cap Attachment: Brass UNS-C36000

For ENT coated sprinklers: Belleville spring - Exposed, Screw and Pipcap - ENT plated.

**Ordering Information:** (Also refer to the current Viking price list.)

**Sprinkler:** Base Part No. 16240

Order Sprinkler VK484 by first adding the appropriate suffix for the sprinkler finish and then the appropriate suffix for the temperature rating to the sprinkler base part number.

Finish Suffix: Brass = A, Chrome = F, White Polyester = M-W, Black Polyester = M-B, and ENT = JN

Temperature Suffix: 155 °F (68 °C) = B, 175 °F (79 °C) = D

For example, sprinkler VK484 with a Brass finish and a 155 °F (68 °C) temperature rating = Part No. 16240AB.

#### Available Finishes And Temperature Ratings:

Refer to Table 1.

**Accessories:** (Also refer to the Viking website.)

#### Sprinkler Wrenches:

A. Standard Wrench: Part No. 21475MB (available since 2017)

B. Wrench for recessed sprinklers: Part No. 13655WB†† (available since 2006)

††A 1/2" ratchet is required (not available from Viking).

#### Sprinkler Cabinets:

A. Six-head capacity: Part No. 01724A (available since 1971)

B. Twelve-head capacity: Part No. 01725A (available since 1971)



## TECHNICAL DATA

## FREEDOM® RESIDENTIAL HORIZONTAL SIDEWALL SPRINKLER VK484 (K4.2)

The Viking Corporation, 210 N Industrial Park Drive, Hastings MI 49058

Telephone: 269-945-9501 Technical Services: 877-384-5464 Fax: 269-818-1680 Email: techsvcs@vikingcorp.com

Visit the Viking website for the latest edition of this technical data page [www.vikinggroupinc.com](http://www.vikinggroupinc.com)

### 4. INSTALLATION

Refer to appropriate NFPA Installation Standards.

### 5. OPERATION

During fire conditions, the heat-sensitive liquid in the glass bulb expands, causing the glass to shatter, releasing the pip cap and sealing spring assembly. Water flowing through the sprinkler orifice strikes the sprinkler deflector, forming a uniform spray pattern to extinguish or control the fire.

### 6. INSPECTIONS, TESTS AND MAINTENANCE

Refer to NFPA 25 for Inspection, Testing and Maintenance requirements.

### 7. AVAILABILITY

The Viking Model VK484 Sprinkler is available through a network of domestic and international distributors. See The Viking Corporation web site for the closest distributor or contact The Viking Corporation.

### 8. GUARANTEE

For details of warranty, refer to Viking's current list price schedule or contact Viking directly.

**TABLE 1: AVAILABLE SPRINKLER TEMPERATURE RATINGS AND FINISHES**

Sprinkler Temperature Classification	Sprinkler Nominal Temperature Rating <sup>1</sup>	Maximum Ambient Ceiling Temperature <sup>2</sup>	Bulb Color
Ordinary	155 °F (68 °C)	100 °F (38 °C)	Red
Intermediate	175 °F (79 °C)	150 °F (65 °C)	Yellow

**Sprinkler Finishes:** Brass, Chrome, White Polyester<sup>3</sup>, Black Polyester<sup>3</sup>, and ENT<sup>3,4</sup>

#### Footnotes

<sup>1</sup> The sprinkler temperature rating is stamped on the deflector.

<sup>2</sup> Based on NFPA-13. Other limits may apply, depending on fire loading, sprinkler location, and other requirements of the Authority Having Jurisdiction. Refer to specific installation standards.

<sup>3</sup> Sprinklers with ENT, White Polyester, and Black Polyester finishes are C-UL-US-EU Listed as corrosion resistant.

<sup>4</sup> The ENT coating has passed the standard corrosion test required by the approving agencies indicated in the Approval Chart. These tests cannot and do not represent all possible corrosive environments. Prior to installation, verify through the end-user that the coatings are compatible with or suitable for the proposed environment. For ENT coated sprinklers, the waterway is coated. Note that the spring is exposed on sprinklers with ENT coating.

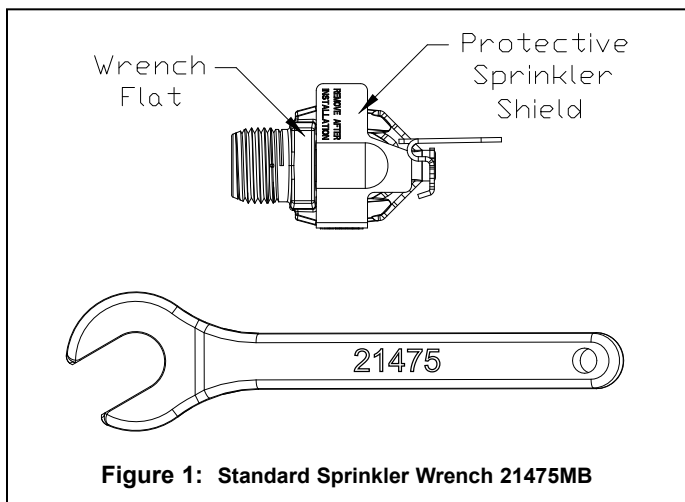

**Figure 1: Standard Sprinkler Wrench 21475MB**



## TECHNICAL DATA

## FREEDOM® RESIDENTIAL HORIZONTAL SIDEWALL SPRINKLER VK484 (K4.2)

The Viking Corporation, 210 N Industrial Park Drive, Hastings MI 49058  
 Telephone: 269-945-9501 Technical Services: 877-384-5464 Fax: 269-818-1680 Email: techsvcs@vikingcorp.com  
 Visit the Viking website for the latest edition of this technical data page www.vikinggroupinc.com

### Approval Chart Viking VK484, 4.2 K-Factor Residential Horizontal Sidewall Sprinkler

For systems designed to NFPA 13D or NFPA 13R. For systems designed to NFPA 13, refer to the design criteria. For Ceiling types refer to NFPA 13, 13R or 13D current editions

Sprinkler Base Part Number <sup>1</sup>	SIN	NPT Thread Size		Nominal K-Factor		Maximum Water Working Pressure	Overall Length							
		Inches	mm	U.S.	metric <sup>2</sup>		Inches	mm						
16240	VK484	1/2	15	4.2	57	175 psi (12 bar)	3	76						
Max. Coverage Area <sup>4</sup> Width X Length Ft. X Ft. (m X m)	Max. Spacing Ft. (m)	Ordinary Temp Rating (155 °F/68 °C)		Intermediate Temp Rating (175 °F/79 °C)		Top of Deflector to Ceiling	Installation Type	Listings and Approvals <sup>3</sup>		Minimum Spacing Ft. (m)				
		Flow <sup>4</sup> GPM (L/min)	Pressure <sup>4</sup> PSI (bar)	Flow <sup>4</sup> GPM (L/min)	Pressure <sup>4</sup> PSI (bar)			C-UL-US-EU <sup>5</sup>	NYC					
12 X 12 (3.7 X 3.7)	12 (3.7)	13 (49.2)	9.6 (0.66)	13 (49.2)	9.6 (0.66)	4 to 6 inches	Standard surface-mounted escutcheons or recessed with the Micromatic® Model E-1, E-2, E-3, or G-1 Recessed Escutcheon	See Footnotes 7 and 9.	See Footnote 6	8 (2.4)				
14 X 14 (4.3 X 4.3)	14 (4.3)	14 (53.0)	11.1 (0.77)	15 (56.8)	12.8 (0.88)									
16 X 16 (4.9 X 4.9)	16 (4.9)	16 (60.6)	14.5 (1.00)	17 (64.4)	16.4 (1.13)									
16 X 18 (4.9 X 5.5)	16 (4.9)	19 (71.9)	20.5 (1.41)	19 (71.9)	20.5 (1.41)									
16 X 20 (4.9 X 6.1)	16 (4.9)	22 (83.3)	27.4 (1.89)	22 (83.3)	27.4 (1.89)									
12 X 12 (3.7 X 3.7)	12 (3.7)	14 (53.0)	11.1 (0.77)	14 (53.0)	11.1 (0.77)	6 to 12 inches					Standard surface-mounted escutcheons or recessed with the Micromatic® Model E-1, E-2, E-3, or G-1 Recessed Escutcheon	See Footnotes 7 and 9.	See Footnote 6	8 (2.4)
14 X 14 (4.3 X 4.3)	14 (4.3)	16 (60.6)	14.5 (1.00)	16 (60.6)	14.5 (1.00)									
16 X 16 (4.9 X 4.9)	16 (4.9)	18 (68.1)	18.4 (1.27)	18 (68.1)	18.4 (1.27)									
16 X 18 (4.9 X 5.5)	16 (4.9)	20 (75.7)	22.7 (1.56)	20 (75.7)	22.7 (1.56)									
16 X 20 (4.9 X 6.1)	16 (4.9)	25 (94.6)	35.4 (2.44)	25 (94.6)	35.4 (2.44)									

#### Footnotes

- <sup>1</sup> Part number shown is the base part number. For complete part number, refer to Viking's current price schedule.
- <sup>2</sup> Metric K-factor measurement shown is when pressure is measured in Bar. When pressure is measured in kPa, divide the metric K-factor shown by 10.0.
- <sup>3</sup> This chart shows the listings and approvals available at the time of printing. Other approvals may be in process. Check with the manufacturer for any additional approvals. Refer also to Design Criteria.
- <sup>4</sup> For areas of coverage smaller than shown, use the "Flow" and "Pressure" for the next larger area listed. Flows and pressures listed are per sprinkler.
- <sup>5</sup> Listed by Underwriter's Laboratories, Inc. for use in the U.S., Canada, and the European Union.
- <sup>6</sup> Meets New York City requirements, effective July 1, 2008.
- <sup>7</sup> Approved Finishes are: Brass, Chrome, White Polyester, and Black Polyester <sup>8</sup>
- <sup>8</sup> Other paint colors are available on request with the same cULus listings as the standard finish colors.
- <sup>9</sup> Approved finish is Electroless Nickel PTFE (ENT). Sprinklers with ENT, White Polyester, and Black Polyester finishes are C-UL-US-EU Listed as corrosion resistant. ENT is available with standard surface-mounted escutcheons or the Model E-1 Recessed Escutcheon.



**TECHNICAL DATA**

**FREEDOM® RESIDENTIAL  
HORIZONTAL SIDEWALL  
SPRINKLER VK484 (K4.2)**

The Viking Corporation, 210 N Industrial Park Drive, Hastings MI 49058  
 Telephone: 269-945-9501 Technical Services: 877-384-5464 Fax: 269-818-1680 Email: techsvcs@vikingcorp.com  
 Visit the Viking website for the latest edition of this technical data page www.vikinggroupinc.com

**DESIGN CRITERIA**

(Also refer to the Approval Chart.)

**cULus Listing Requirements:**

When using Viking Residential Sprinkler VK484 for systems designed to NFPA 13D or NFPA 13R, apply the listed areas of coverage and minimum water supply requirements shown in the Approval Chart.

For systems designed to NFPA 13: The number of design sprinklers is to be the four contiguous most hydraulically demanding sprinklers. The minimum required discharge from each of the four sprinklers is to be the greater of the following:

- The flow rates given in the Approval Chart for NFPA 13D and NFPA13R applications for each listed area of coverage, or
- Calculated based on a minimum discharge of 0.1 gpm/sq. ft. over the “design area” in accordance with sections 8.5.2.1 or 8.6.2.1.2 of NFPA 13.
- Minimum distance between residential sprinklers: 8 ft. (2.4 m).
- The VK484 horizontal sidewall sprinkler deflector shall be located a minimum of 1-3/4” (44.5 mm) and a maximum of 6” (152 mm) from the wall on which it is installed.

**DEFLECTOR POSITION:** Install Viking Residential Horizontal Sidewall Sprinkler VK484 with the leading edge of the deflector oriented parallel with the ceiling and the sprinkler frame arms oriented perpendicular to the ceiling. Refer to the Approval Chart for the required distance between the top of the deflector and the ceiling.

**IMPORTANT:** Always refer to Bulletin Form No. F\_091699 - Care and Handling of Sprinklers. Also refer to Form No. F\_080614 for general care, installation, and maintenance information. Viking sprinklers are to be installed in accordance with the latest edition of Viking technical data, the appropriate standards of NFPA and any other similar Authorities Having Jurisdiction, and also with the provisions of governmental codes, ordinances, and standards, whenever applicable. Final approval and acceptance of all residential sprinkler installations must be obtained from the Authorities Having Jurisdiction.

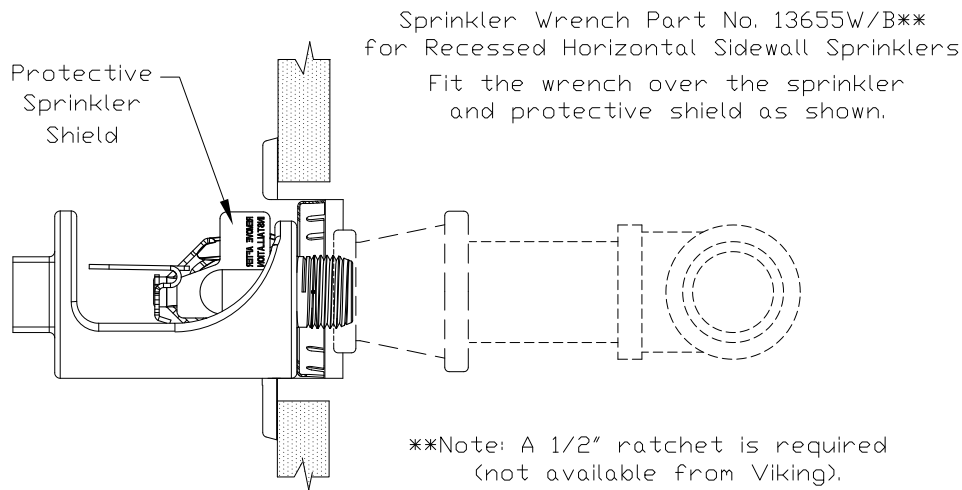

**Figure 2: Wrench 13655W/B for Recessed Sprinkler VK484**



**TECHNICAL DATA**

**FREEDOM® RESIDENTIAL  
HORIZONTAL SIDEWALL  
SPRINKLER VK484 (K4.2)**

The Viking Corporation, 210 N Industrial Park Drive, Hastings MI 49058  
 Telephone: 269-945-9501 Technical Services: 877-384-5464 Fax: 269-818-1680 Email: techsvcs@vikingcorp.com  
 Visit the Viking website for the latest edition of this technical data page www.vikinggroupinc.com

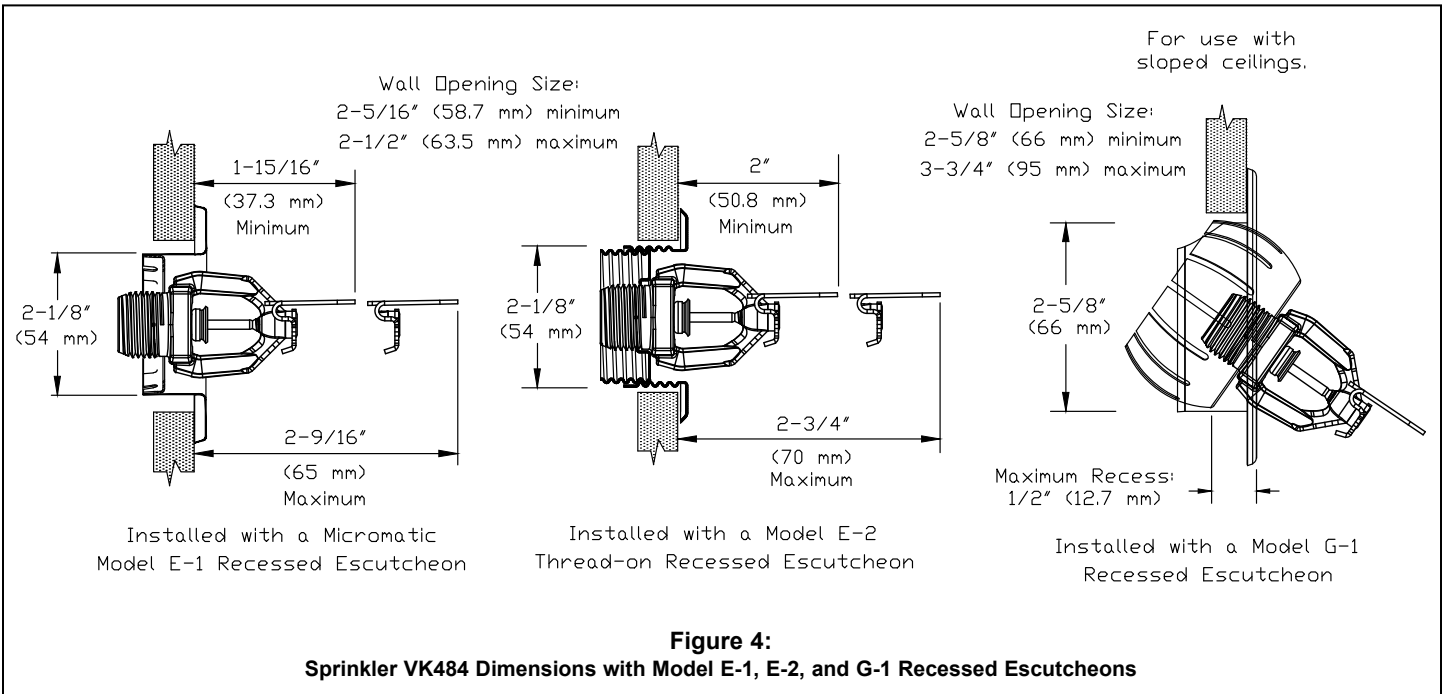
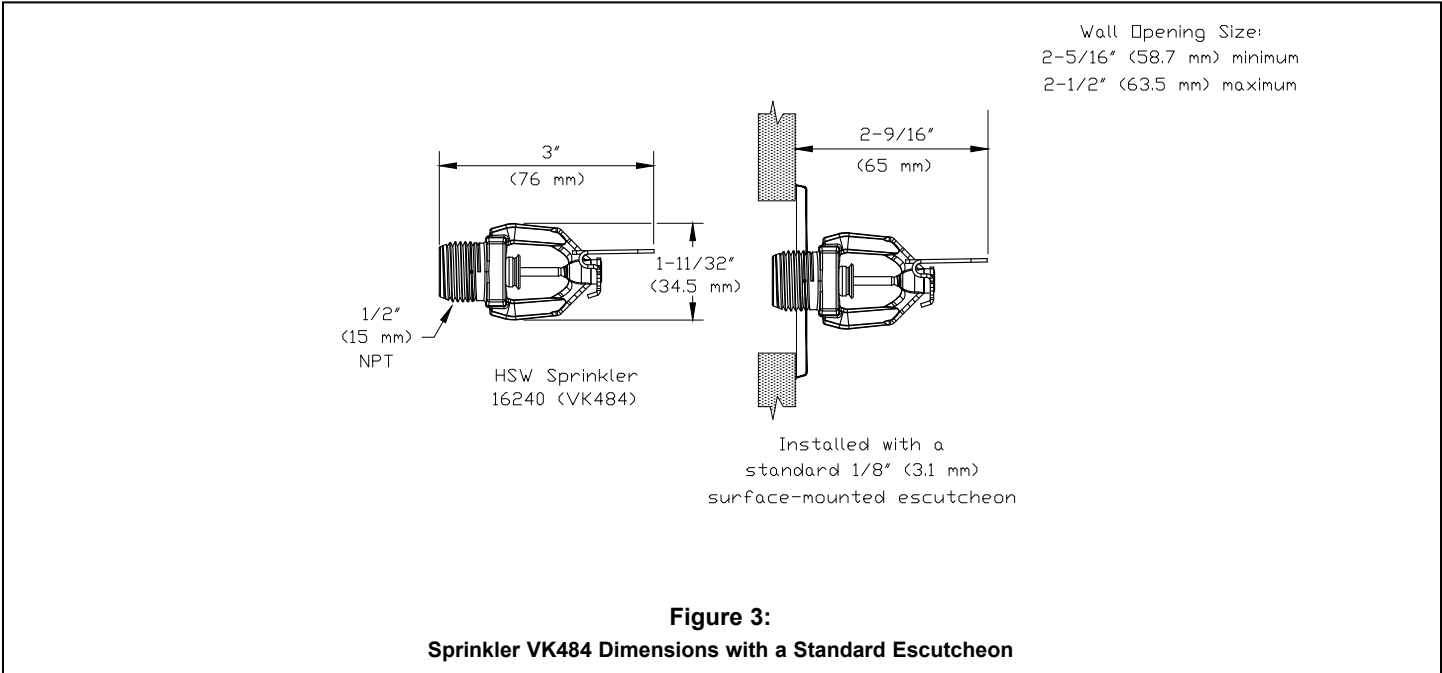



# Viking Residential Sprinkler Installation Guide

**October 25, 2018**



**WARNING:** Cancer and Reproductive Harm-  
[www.P65Warnings.ca.gov](http://www.P65Warnings.ca.gov)

Trusted Above All™

[www.vikinggroupinc.com](http://www.vikinggroupinc.com)



## TECHNICAL DATA

## FREEDOM® RESIDENTIAL SPRINKLER INSTALLATION GUIDE

The Viking Corporation, 210 N Industrial Park Drive, Hastings MI 49058

Telephone: 269-945-9501 Technical Services: 877-384-5464 Fax: 269-818-1680 Email: techsvcs@vikingcorp.com

### 1. DESCRIPTION

Viking residential automatic sprinklers are equipped with a “fast response” heat-sensitive operating element designed to respond individually and quickly to a specific high temperature. Viking residential sprinklers are designed to combine speed of operation with water distribution characteristics to help in the control of residential fires and to improve life safety by prolonging the time available for occupants to escape or be evacuated.

### 2. LISTINGS AND APPROVALS

Refer to the Approval Charts on the appropriate sprinkler technical data page(s) and/or approval agency listings.

- A. Viking residential sprinklers are intended for use in the following occupancies: one- and two-family dwellings and mobile homes with the fire protection sprinkler system installed in accordance with NFPA 13D; residential occupancies up to four stories in height with the fire protection system installed in accordance with NFPA 13R; or residential portions of any occupancy with the fire protection system installed in accordance with NFPA 13. Information contained in this guide is based on NFPA 13, “Standard for the Installation of Sprinkler Systems”.
- B. The design criteria for residential sprinklers contained in the NFPA installation standards must be followed except as modified by the individual UL 1626 listing information provided in the technical data pages and this Residential Sprinkler Installation Guide. For listed areas of coverage, technical data, and specific design and installation instructions, refer to the appropriate Viking technical data page for the sprinkler model used.
- C. Viking residential sprinklers listed by Underwriters Laboratories, Inc. (UL) have passed fire tests designed to represent fire conditions for the sprinkler’s listed area of coverage. The standards for residential sprinkler performance and spray patterns are printed in Underwriters Laboratories Publication UL 1626, “Standard for Residential Sprinklers for Fire Protection Service”. All listed Viking residential sprinklers meet or exceed UL 1626 performance requirements and spray pattern criteria for their listed areas of coverage.
- D. NFPA standards allow use of residential sprinklers with rates, design areas, areas of coverage, and minimum design pressures other than those specified in the standards when they have been listed for such specific residential installation conditions.

### 3. TECHNICAL DATA

#### Specifications:

Refer to the appropriate sprinkler technical data sheet.

#### Material Standards:

Refer to the appropriate sprinkler technical data sheet.

Viking Technical Data may be found on  
The Viking Corporation’s Web site at  
<http://www.vikinggroupinc.com>.  
The Web site may include a more recent  
edition of this Technical Data Page.

### 4. INSTALLATION

**NOTE: Take care not to over-tighten the sprinkler and/or damage its operating parts!**

**Maximum Torque: 1/2” NPT: 14 ft-lbs. (19.0 N-m)      3/4” NPT: 20 ft-lbs. (27.1 N-m)**

#### A. Care and Handling (also refer to Bulletin - Care and Handling of Sprinklers, Form No. F\_091699.)

Sprinklers must be handled with care and protected from mechanical damage during storage, transport, handling, and after installation.

Store sprinklers in a cool, dry place in their original container.

Use care when locating sprinklers near fixtures that can generate heat.

Never install sprinklers that have been dropped, damaged in any way, or exposed to temperatures exceeding the maximum ambient temperature allowed (refer to Table 1.)

Never install any glass-bulb sprinkler if the bulb is cracked or if there is a loss of liquid from the bulb. A small air bubble should be present in the glass bulb. Any sprinkler with a loss of liquid from the glass bulb or damage to the fusible element should be destroyed immediately. (Note: Installing glass bulb sprinklers in direct sunlight (ultraviolet light) may affect the color of the dye used to color code the bulb. This color change does not affect the integrity of the bulb.)

Viking residential sprinklers are intended for use on wet pipe residential systems only. Adequate heat must be provided for wet-pipe systems. DO NOT use Viking residential sprinklers on dry systems unless specifically allowed by recognized installation standards or the Authority Having Jurisdiction.

**Residential concealed sprinklers must be installed in neutral or negative pressure plenums only!**

Corrosion-resistant sprinklers must be installed when subject to corrosive atmospheres. **NOTE:** Viking residential sprinklers are not intended for use in corrosive environments.

Replaces pages 1-17, dated December 1, 2016.

(Added P65 Warning.)





## TECHNICAL DATA

## FREEDOM® RESIDENTIAL SPRINKLER INSTALLATION GUIDE

The Viking Corporation, 210 N Industrial Park Drive, Hastings MI 49058

Telephone: 269-945-9501 Technical Services: 877-384-5464 Fax: 269-818-1680 Email: techsvcs@vikingcorp.com

**TABLE 1: RESIDENTIAL SPRINKLER TEMPERATURE RATINGS**

Sprinkler Temperature Classification	Sprinkler Nominal Temperature Rating <sup>1</sup>	Maximum Ambient Ceiling Temperature <sup>3</sup>	Bulb Color
<b>Residential Glass Bulb Style Sprinklers</b>			
Ordinary	155 °F (68 °C)	100 °F (38 °C)	Red
Intermediate	175 °F (79 °C)	150 °F (65 °C)	Yellow
Sprinkler Temperature Classification	Sprinkler Nominal Temperature Rating (Fusing Point) <sup>1</sup>	Maximum Ambient Ceiling Temperature <sup>3</sup>	
<b>Residential Fusible Element Style Sprinklers</b>			
Ordinary	165 °F (74 °C)	100 °F (38 °C)	
Sprinkler Temperature Classification	Sprinkler Nominal Temperature Rating (Fusing Point)	Maximum Ambient Ceiling Temperature <sup>3</sup>	Temperature Identification Stamp
<b>Residential Flush Style Sprinklers</b>			
Ordinary	165 °F (74 °C)	100 °F (38 °C)	On Cover or Sprinkler Inlet (VK476)
Intermediate	220 °F (104 °C)	150 °F (65 °C)	On Cover
Sprinkler Temperature Classification	Sprinkler Nominal Temperature Rating (Fusing Point)	Maximum Ambient Ceiling Temperature <sup>3</sup>	Cover Plate Temperature Rating
<b>Residential Concealed Style Sprinklers</b>			
Ordinary	135 °F (57 °C) <sup>1</sup> , 140 °F (60 °C) <sup>2</sup> , 155 °F (68 °C) <sup>1</sup> , or 165 °F (74 °C) <sup>1</sup>	100 °F (38 °C)	135 °F (57 °C)
<b>Footnotes</b>			
<sup>1</sup> The sprinkler temperature rating is stamped on the deflector or flow shaper. <sup>2</sup> The temperature rating is stamped on the sprinkler. <sup>3</sup> Based on NFPA-13. Other limits may apply, depending on fire loading, sprinkler location, and other requirements of the Authority Having Jurisdiction. Refer to specific installation standards.			

### B. Installation Instructions

Viking sprinklers are manufactured and tested to meet the rigid requirements of approving agencies. They are designed to be installed in accordance with recognized installation standards NFPA 13, NFPA 13R, and NFPA 13D, and any associated TIAs.

Deviation from the standards or any alteration to the sprinklers or cover plate assemblies after they leave the factory including, but not limited to: painting, plating, coating, or modification, may render the sprinklers inoperative and will automatically nullify the approval and any guarantee made by Viking.

The use of residential sprinklers may be limited due to occupancy and hazard. Residential fire protection systems must be designed and installed only by those who are completely familiar with the appropriate standards and codes, and thoroughly experienced in fire protection design, hydraulic calculations, and sprinkler system installation.

Before installation, be sure to have the appropriate sprinkler model and style, with the correct K-Factor, temperature rating, and response characteristics. Viking residential sprinklers must be installed after the piping is in place to prevent mechanical damage. Keep sprinklers with protective caps or bulb shields contained within the caps or shields during installation and testing, and any time the sprinkler is shipped or handled.

1a. For frame-style sprinklers, install escutcheon (if used), which is designed to thread onto the external threads of the sprinkler\*.

\*Refer to the appropriate sprinkler technical data page to determine approved escutcheons for use with specific sprinkler models.

1b. For flush and concealed style sprinklers: Cut the sprinkler nipple so that the ½" or ¾" (15 mm or 20 mm) NPT\*\* outlet of the reducing coupling is at the desired location and centered in the opening\*\* in the ceiling or wall.

\*\*Size depends on the sprinkler model used. Refer to appropriate sprinkler data page.



## TECHNICAL DATA

## FREEDOM® RESIDENTIAL SPRINKLER INSTALLATION GUIDE

The Viking Corporation, 210 N Industrial Park Drive, Hastings MI 49058

Telephone: 269-945-9501 Technical Services: 877-384-5464 Fax: 269-818-1680 Email: techsvcs@vikingcorp.com

### DESIGN CRITERIA

**For Systems Designed to NFPA 13D or NFPA 13R:** Apply the listed areas of coverage and minimum water supply requirements shown in the approval charts on the residential sprinkler data pages. The sprinkler flow rate is the minimum required discharge from each of the total number of design sprinklers as specified in NFPA 13D or NFPA 13R.

**For Systems Designed to the latest edition of NFPA 13:** The number of design sprinklers is to be the four most hydraulically demanding sprinklers. The minimum required discharge from each of the four sprinklers is to be the greater of the following:

- The flow rates given in the approval charts on the data pages for NFPA 13D and NFPA13R for each area of coverage listed, or
- Calculated based on a minimum discharge of 0.1 gpm/sq. ft. over the “design area” in accordance with sections 8.5.2.1 or 8.6.2.1.2 of NFPA 13. The greatest dimension of the coverage area cannot be any greater than the maximum areas of coverage shown on the data pages.

#### Flow Rates

All residential sprinklers manufactured on or after July 12, 2002 are listed with a single minimum flow rate. Where rooms have more than one sprinkler, multiple-sprinkler calculations are still required, but the first sprinkler and any additional sprinkler or sprinklers must be calculated flowing at identical minimum flow rates, based on the area of sprinkler coverage, using the minimum flow and pressure listed for the sprinkler model used.

Consult the appropriate standards and the Authorities Having Jurisdiction to determine the number of sprinklers to hydraulically calculate to verify adequate water supply for multiple-sprinkler operation.

Operating Pressure: The minimum operating pressure of any sprinkler shall be the minimum operating pressure specified by the listing, or 7 psi (0.5 bar), whichever is greater. The maximum allowable operating pressure is 175 psi (12 bar).

#### Areas of Coverage

If the actual area of coverage is less than the listed area of coverage, use the minimum water supply for the next larger area of coverage listed. DO NOT interpolate. Residential sprinkler systems must be hydraulically calculated according to NFPA standards to verify that the water supply is adequate for proper operation of the sprinklers. Hydraulic calculations are required to verify adequate water supply at the hydraulically most remote single sprinkler when it is operating at the minimum gpm and psi listed for single-sprinkler operation for the sprinkler model used.

Viking residential sprinklers may be listed for more than one area of coverage. Suggested practice in selecting area of coverage is to select the one that can be adequately supplied by the available water supply and still allow for the installation of as few sprinklers in a compartment as possible while observing all guidelines pertaining to obstructions and spacing. This maximizes the use of the available water supply, which is often limited on residential fire protection systems. After selecting an appropriate area of coverage, sprinklers must be spaced according to guidelines set forth in the installation standards.

**Definition of “COMPARTMENT”:** A space completely enclosed by walls and a ceiling. Openings to an adjoining space are allowed, provided the openings have a minimum lintel depth of 8 in. (203.2 mm) from the ceiling.

#### Spacing Guidelines

For guidelines concerning spacing of Viking residential sprinklers near beams, obstructions, heat sources, and sloped ceilings [slopes more than a 2/12 (9.5°) pitch], refer to the Viking residential sprinkler data pages and installation guide, the appropriate NFPA standard, and the Authority Having Jurisdiction. NOTE: Sloped, beamed, and pitched ceilings could require special design features such as larger flow, or a design for more sprinklers to operate in the compartment, or both.

**Distance from Walls:** Install not more than one-half the listed sprinkler spacing nor less than 4” (102 mm) from walls, partitions, or obstructions as defined in the standards.

**Minimum Sprinkler Spacing:** The minimum distance between residential sprinklers to prevent cold soldering (i.e., the spray from one operating sprinkler onto an adjacent sprinkler that could prevent its proper activation) is 8 ft. (2.4 m).

**Maximum Sprinkler Spacing:** Locate adjacent sprinklers no farther apart than the listed spacing.

**Deflector Position:** Install frame style residential *pendent* sprinklers with the deflector between 1” and 4” (25.4 mm to 102 mm) below smooth ceilings, unless the sprinkler data page indicates otherwise. Install pendent sprinklers in the pendent position only, with the deflector oriented parallel with the ceiling or roof.

Refer to the individual listings in the residential sprinkler data pages for horizontal sidewall sprinkler deflector or sprinkler centerline distance below the ceiling. Install horizontal sidewall sprinklers in the horizontal position only below smooth ceilings, with the leading edge of the deflector or element assembly oriented parallel with the ceiling.

**IMPORTANT: Always refer to Bulletin Form No. F\_091699 - Care and Handling of Sprinklers. Also refer to the appropriate sprinkler data page. Viking sprinklers are to be installed in accordance with the latest edition of Viking technical data, the appropriate standards of NFPA and any other similar Authorities Having Jurisdiction, and also with the provisions of governmental codes, ordinances, and standards, whenever applicable. Final approval and acceptance of all residential sprinkler installations must be obtained from the Authorities Having Jurisdiction.**



## TECHNICAL DATA

## FREEDOM® RESIDENTIAL SPRINKLER INSTALLATION GUIDE

The Viking Corporation, 210 N Industrial Park Drive, Hastings MI 49058

Telephone: 269-945-9501 Technical Services: 877-384-5464 Fax: 269-818-1680 Email: techsvcs@vikingcorp.com

2. Apply a small amount of pipe-joint compound or tape to the external threads of the sprinkler only, taking care not to allow a build-up of compound in the sprinkler inlet. **NOTE:** Sprinklers with protective caps or bulb shields must be contained within the caps or shields before applying pipe-joint compound or tape. *Exception: For concealed sprinklers (i.e., VK457, VK458, VK468, VK474, and VK4570) the protective cap is removed for installation.*
3. Care must be taken when installing sprinklers on CPVC and copper piping systems. Never install the sprinkler into the reducing fitting before attaching the reducing fitting to the piping. Sprinklers must be installed on CPVC systems after the reducing fitting has been installed and the primer and/or cement manufacturer's recommended curing time has elapsed. When installing sprinklers on copper piping systems, take care to brush the inside of the sprinkler supply piping and reducing fitting to ensure that no flux accumulates in the sprinkler orifice. Excess flux can cause corrosion and may impair the ability of the sprinkler to operate properly.
4. Refer to the appropriate sprinkler technical data page to determine the correct sprinkler wrench for the model of sprinkler used. DO NOT use the sprinkler deflector or fusible element to start or thread the sprinkler into a fitting.
  - a. Install the sprinkler onto the piping using the special sprinkler wrench only, while taking care not to over-tighten or damage the sprinkler operating parts.
  - b. Thread the flush or concealed sprinkler into the 1/2" or 3/4" (15 mm or 20 mm) NPT\*\* outlet of the coupling by turning it clockwise with the special sprinkler wrench. *NOTE: For flush and concealed sprinklers with protective shells, the internal diameter of the special flush and concealed sprinkler installation wrench is designed for use with the sprinkler contained within the shell. Exception: For concealed sprinklers VK457, VK458, VK468, VK474, and VK4570 the protective cap is removed for installation, and then placed back on the sprinkler temporarily.*
5. After installation, the entire sprinkler system must be tested. The test must be conducted to comply with the installation standards.
  - a. Make sure the sprinkler has been properly tightened. If a thread leak occurs, normally the unit must be removed, new pipe-joint compound or tape applied, and then reinstalled. This is due to the fact that when the joint seal leaks, the sealing compound is washed out of the joint.
  - b. **Remove plastic protective sprinkler caps or bulb shields AFTER the wall or ceiling finish work is completed where the sprinkler is installed and there no longer is a potential for mechanical damage to the sprinkler operating elements.** To remove the bulb shields, simply pull the ends of the shields apart where they are snapped together. To remove caps from frame style sprinklers, turn the caps slightly and pull them off the sprinklers. **SPRINKLER CAPS OR BULB SHIELDS MUST BE REMOVED FROM SPRINKLERS BEFORE PLACING THE SYSTEM IN SERVICE!** Retain a protective cap or shield in the spare sprinkler cabinet.
6. For residential flush sprinklers, the ceiling ring can now be installed onto the sprinkler body. Align the ceiling ring with the sprinkler body and thread on or push it on until the flange touches the ceiling. Note the maximum vertical adjustment is 1/2" (12,7 mm) for sprinkler VK420 and 5/8" for VK476. DO NOT MODIFY THE UNIT. If necessary, re-cut the sprinkler drop nipples as required.
7. For residential concealed sprinklers, the cover plate assembly can now be attached.
  - a. Remove the cover plate assembly from the protective box, taking care not to damage the assembly.
  - b. From below the ceiling, gently place the base of the cover plate assembly over the sprinkler protruding through the opening in the ceiling or wall.
  - c. Carefully push the cover plate assembly onto the sprinkler, using even pressure with the palm of the hand, until the unfinished brass flange of the cover plate base touches the ceiling or wall.
  - d. The maximum adjustment available for residential concealed sprinklers is 1/2" (12.7 mm) [1/4" (6.4 mm) for sprinkler VK480]. DO NOT MODIFY THE UNIT. If necessary, re-cut the sprinkler nipples.

**NOTE:** If it is necessary to remove the entire sprinkler unit, the system must be taken out of service. See Maintenance instructions below and follow all warnings and instructions.

## 5. OPERATION

During fire conditions, the operating element fuses or shatters (depending on the type of sprinkler), releasing the pip cap and sealing assembly. Water flowing through the sprinkler orifice strikes the sprinkler deflector or flow shaper, forming a uniform, high-wall wetting spray pattern to extinguish or control the fire.



## TECHNICAL DATA

## FREEDOM® RESIDENTIAL SPRINKLER INSTALLATION GUIDE

The Viking Corporation, 210 N Industrial Park Drive, Hastings MI 49058

Telephone: 269-945-9501 Technical Services: 877-384-5464 Fax: 269-818-1680 Email: techsvcs@vikingcorp.com

### 6. INSPECTIONS, TESTS AND MAINTENANCE

Refer to NFPA 25 for Inspection, Testing and Maintenance requirements. **NOTICE:** The owner is responsible for having the fire-protection system and devices inspected, tested, and maintained in proper operating condition in accordance with this guide, and applicable NFPA standards. In addition, the Authority Having Jurisdiction may have additional maintenance, testing, and inspection requirements that must be followed.

- A. Sprinklers must be inspected on a regular basis for signs of corrosion, mechanical damage, obstructions, paint, etc. Frequency of the inspections may vary due to corrosive atmospheres, water supplies, and activity around the device.
- B. Sprinklers or cover plate assemblies that have been field painted, caulked, or mechanically damaged must be replaced immediately. Sprinklers showing signs of corrosion shall be tested and/or replaced immediately as required. Installation standards require sprinklers to be tested and, if necessary, replaced immediately after a specified term of service. Refer to NFPA 25 and the Authorities Having Jurisdiction for the specified period of time after which testing and/or replacement of residential sprinklers is required. Never attempt to repair or reassemble a sprinkler. Sprinklers and cover assemblies that have operated cannot be reassembled or re-used, but must be replaced. When replacement is necessary, use only new sprinklers and cover assemblies with identical performance characteristics.
- C. The sprinkler discharge pattern is critical for proper fire protection. Nothing should be hung from, attached to, or otherwise obstruct the discharge pattern of the sprinkler. All obstructions must be immediately removed or, if necessary, additional sprinklers installed.
- D. When replacing existing sprinklers, the system must be removed from service. Refer to the appropriate system description and/or valve instructions. Prior to removing the system from service, notify all Authorities Having Jurisdiction. Consideration should be given to employment of a fire patrol in the effected area.
  1. Remove the system from service, drain all water, and relieve all pressure on the piping.
  - 2a. For frame-style sprinklers, use the special sprinkler wrench and remove the old sprinkler by turning it counterclockwise to unthread it from the piping.
  - 2b. *For residential flush pendent and concealed style sprinklers: Remove the ceiling ring or cover plate assembly before unthreading the sprinkler body from the piping. To remove a ceiling ring, grasp it from below the ceiling and gently turn it counterclockwise. Cover plates can be removed either by gently unthreading them or pulling them off the sprinkler body (depends on the sprinkler model used). After the ceiling ring or cover plate assembly has been removed from the sprinkler, use the sprinkler wrench to unthread the sprinkler from the piping. NOTE: For flush and concealed sprinklers with protective shells, the internal diameter of the special flush and concealed sprinkler installation wrench is designed for use with the sprinkler contained within the shell. Place a plastic protective shell (from the spare sprinkler cabinet) over the sprinkler to be removed and then fit the sprinkler wrench over the shell. Exception: Concealed sprinklers VK457, VK458, VK468, VK474, and VK4570 are removed without the plastic cap.*
  3. Follow instructions in section 4B. Installation Instructions to install the new unit. Be sure the replacement sprinkler is the correct model and style, with the appropriate K-Factor, temperature rating, and response characteristics. A fully stocked sprinkler cabinet should be provided for this purpose. *(For flush or concealed style sprinklers, stock of spare ceiling rings or cover plates should also be available in the spare sprinkler cabinet.)*
  4. Place the system back in service and secure all valves. Check for and repair all leaks.
- E. Sprinkler systems that have been subjected to a fire must be returned to service as soon as possible. The entire system must be inspected for damage, and repaired or replaced as necessary. Sprinklers that have been exposed to corrosive products of combustion or high ambient temperatures, but have not operated, should be replaced. Refer to the Authority Having Jurisdiction for minimum replacement requirements.

### 7. AVAILABILITY

Viking Residential Sprinklers are available through a network of domestic and international distributors. See The Viking Corporation web site for the closest distributor or contact The Viking Corporation.

### 8. GUARANTEE

For details of warranty, refer to Viking's current list price schedule or contact Viking directly.

<h1>VIKING</h1>	<h2>TECHNICAL DATA</h2>	<h3>FREEDOM® RESIDENTIAL SPRINKLER INSTALLATION GUIDE</h3>
-----------------	-------------------------	--

The Viking Corporation, 210 N Industrial Park Drive, Hastings MI 49058  
 Telephone: 269-945-9501 Technical Services: 877-384-5464 Fax: 269-818-1680 Email: techsvcs@vikingcorp.com

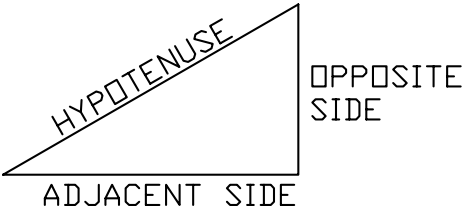

TANGENT =  
 OPPOSITE SIDE (RISE)  
 ADJACENT SIDE (RUN)

$$\frac{\text{RISE}}{\text{RUN}} = \text{TANGENT}$$

$$\text{ANGLE} = \text{TAN}^{-1} \left( \frac{\text{RISE}}{\text{RUN}} \right)$$

$$\text{SLOPE DISTANCE} = \sqrt{(\text{RISE})^2 + (\text{RUN})^2}$$

RISE	RUN	TANGENT	ANGLE	SLOPE DISTANCE
2	12	.1666	9.45°	12.1
3	12	.2500	14°	12.3
4	12	.3333	18.4°	12.6
5	12	.4166	22.6°	13
6	12	.5000	26.5°	13.4
7	12	.5833	30.2°	13.8
8	12	.6666	33.6°	14.4
9	12	.7500	36.8°	15
10	12	.8333	39.8°	15.6
11	12	.9166	42.5°	16.2
12	12	1	45°	16.97

**Table 2**  
 Rise Over Run Conversion to Degrees of Slope

	<b>TECHNICAL DATA</b>	<b>FREEDOM® RESIDENTIAL SPRINKLER INSTALLATION GUIDE</b>
---	-----------------------	--

The Viking Corporation, 210 N Industrial Park Drive, Hastings MI 49058  
 Telephone: 269-945-9501 Technical Services: 877-384-5464 Fax: 269-818-1680 Email: techsvcs@vikingcorp.com

**SPACING OF RESIDENTIAL SPRINKLERS LISTED FOR USE  
BELOW SLOPED CEILINGS UP TO AN 8/12 (33.7°) PITCH**  
 (Refer to the appropriate residential sprinkler technical data page for listings.)

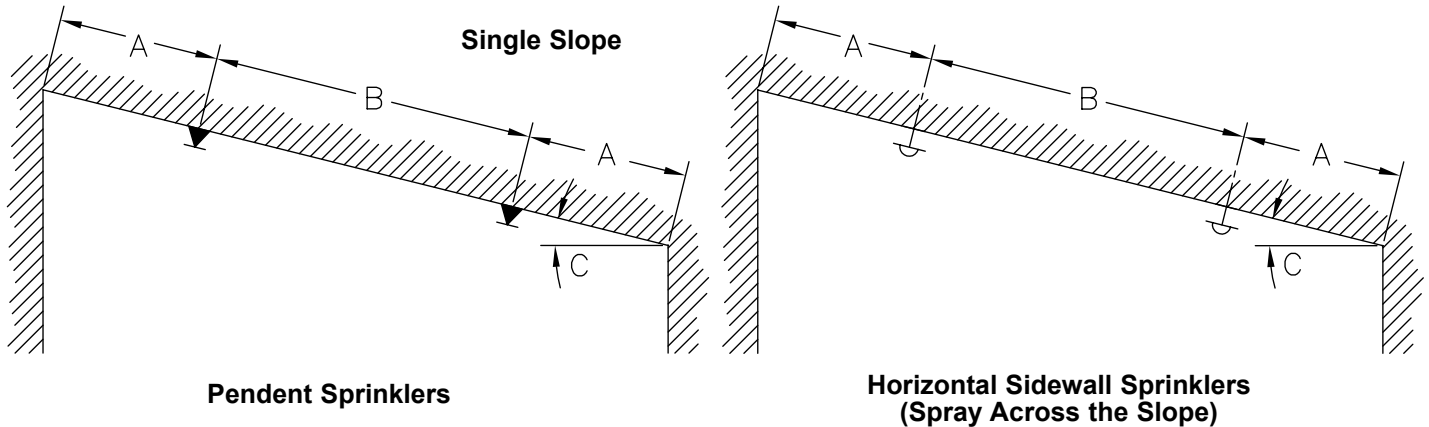

**Figure 1**

- (A) One-half listed spacing of sprinkler maximum, 0'-4" (0-102 mm) minimum.
- (B) Listed spacing of sprinkler, maximum, 8'-0" (2.4 m) minimum.
- (C) Where angle "C" is greater than an 8/12 (33.7°) pitch, see Figure 2 below.

**SPACING OF RESIDENTIAL SPRINKLERS BELOW SLOPED  
CEILINGS WITH GREATER THAN 8/12 (33.7°) PITCH**  
 (NOTE: Refer to NFPA 13D or NFPA 13R, and the Authority Having Jurisdiction.)

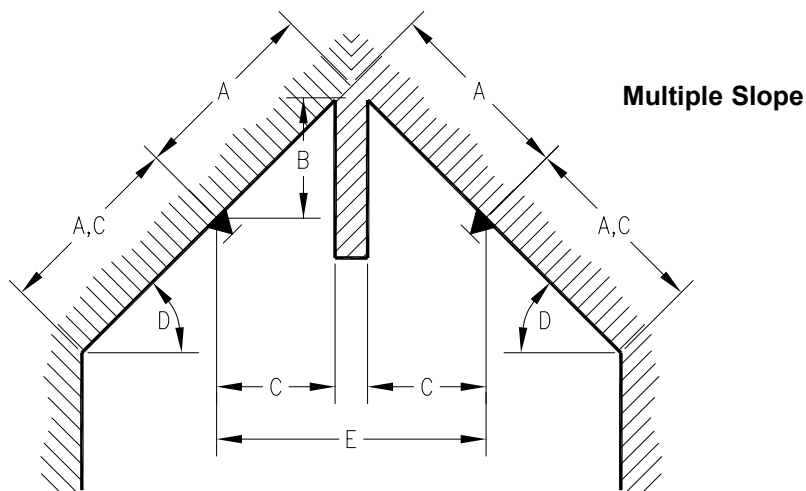

**Figure 2**

- (A) One-half listed spacing of sprinkler, maximum.
- (B) 3'-0" (.91 m) maximum.
- (C) 0'-4" (0-102 mm) minimum.
- (D) Slopes greater than an 8/12 (33.7°) pitch.
- (E) For distance less than 8'-0" (2.4 m), baffle required.



## TECHNICAL DATA

## FREEDOM® RESIDENTIAL SPRINKLER INSTALLATION GUIDE

The Viking Corporation, 210 N Industrial Park Drive, Hastings MI 49058  
 Telephone: 269-945-9501 Technical Services: 877-384-5464 Fax: 269-818-1680 Email: techsvcs@vikingcorp.com

### SPACING OF RESIDENTIAL SPRINKLERS LISTED FOR USE BELOW SLOPED CEILINGS UP TO AN 8/12 (33.7°) PITCH

(Refer to the appropriate residential sprinkler technical data page for listings.)

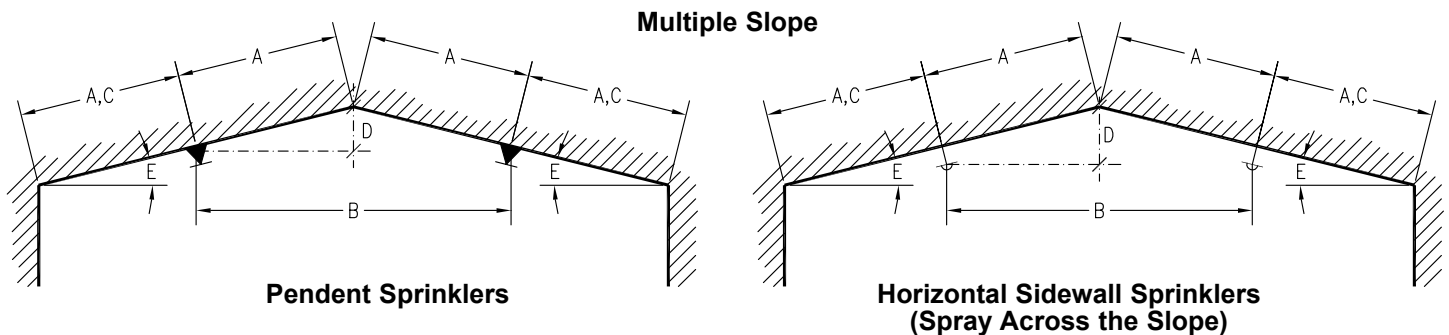
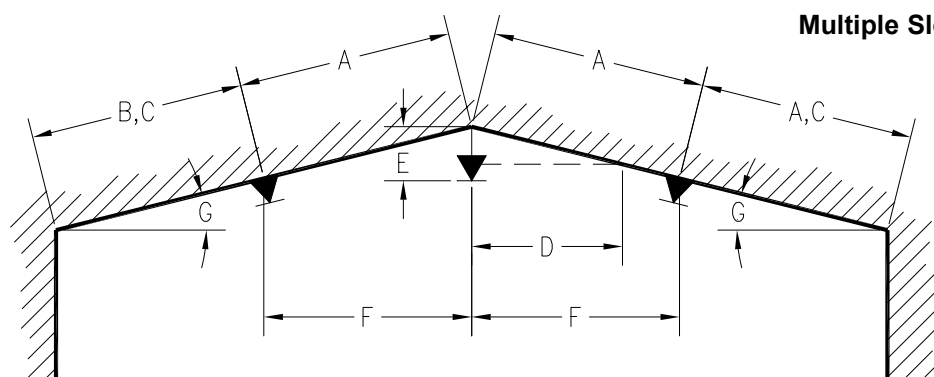

**Figure 3**

- (A) One-half listed spacing of sprinkler, maximum.
- (B) 8'-0" (2.4 m) minimum.
- (C) 0'-4" (0-102 mm) minimum.
- (D) 3'-0" (.91 m) maximum.
- (E) Acceptable for slopes of 0/12 to 8/12 (0° to 33.7°) pitch.

### SPACING OF RESIDENTIAL PENDENT SPRINKLERS AT PEAK OF SLOPED CEILINGS WITH PITCH LESS THAN 8/12 (33.7°)

(Refer to the appropriate residential sprinkler technical data page for listings.)



**Figure 4**

- (A) Listed spacing of sprinkler, maximum.
- (B) One-half listed spacing of sprinkler, maximum.
- (C) 0'-4" minimum.
- (D) Refer to page 10 for minimum distance between sprinkler and intersecting sloped ceiling.
- (E) Refer to the appropriate residential sprinkler technical data page for deflector distance below ceiling.
- (F) 8'-0" minimum.
- (G) Reference: 4/12 (18.0°) pitch maximum for 12' (3.7 m) spacing.  
 2.5/12 (12.0°) pitch maximum for 14' (4.3 m) spacing.  
 2/12 (10.0°) pitch maximum for 16' (4.9 m) spacing.  
 2/12 (10.0°) pitch maximum for 18' (5.5 m) spacing.  
 1.9/12 (9.0°) pitch maximum for 20' (6.1 m) spacing.  
 Angles based on sprinklers installed 0'-4" (0-102 mm) from peak.

**NOTE:** Whenever possible, utilize design as shown in Figure 3 above.



**TECHNICAL DATA**

**FREEDOM® RESIDENTIAL  
SPRINKLER  
INSTALLATION GUIDE**

The Viking Corporation, 210 N Industrial Park Drive, Hastings MI 49058

Telephone: 269-945-9501 Technical Services: 877-384-5464 Fax: 269-818-1680 Email: techsvcs@vikingcorp.com

**SPACING OF RESIDENTIAL SPRINKLERS BELOW SLOPED CEILINGS WITH GREATER THAN 8/12 (33.7°) PITCH WITH NO BAFFLE AND A MAXIMUM OF 2 SPRINKLERS IN THE ROOM**  
(NOTE: Refer to NFPA 13D or NFPA 13R, and the Authority Having Jurisdiction.)

**Multiple Slope**

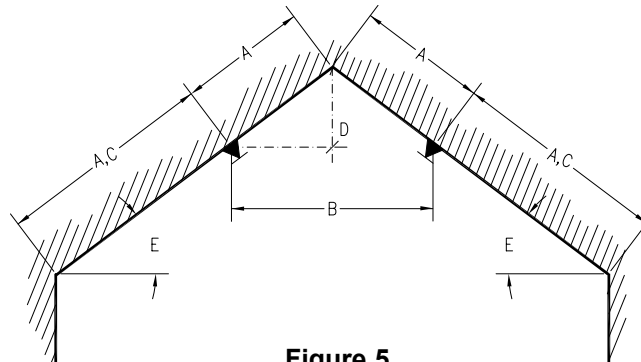
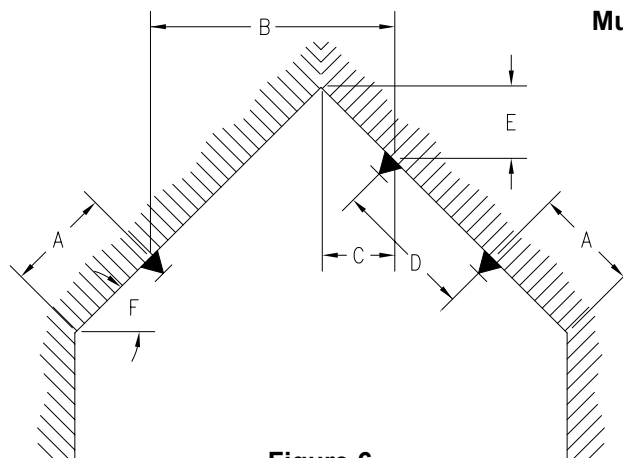

**Figure 5**

- (A) One-half listed spacing of sprinkler, maximum.
- (B) 8'-0" (2.4 m) minimum.
- (C) 0'-4" (0-102 mm) minimum.
- (D) 3'-0" (.91 m) maximum.
- (E) Acceptable for slopes greater than an 8/12 (33.7°) pitch.
- (F) When this design is used, refer to the appendices of NFPA 13D or NFPA 13R, and the Authority Having Jurisdiction regarding the number of design sprinklers to hydraulically calculate.

**SPACING OF RESIDENTIAL SPRINKLERS BELOW CEILINGS WITH SLOPES EXCEEDING 8/12 (33.7°) PITCH WITH NO BAFFLE AND A MAXIMUM OF 3 SPRINKLERS IN THE ROOM**  
(NOTE: Refer to NFPA 13D or NFPA 13R, and the Authority Having Jurisdiction.)

**Multiple Slope**



**Figure 6**

- (A) 0'-4" (0-102 mm) minimum, to one-half listed spacing, maximum.
- (B) One-half listed spacing, maximum, 8'-0" (2.4 m) minimum.
- (C) 0'-4" (0-102 mm) minimum.
- (D) Listed spacing maximum, 8'-0" (2.4 m) minimum.
- (E) 3'-0" (.91 m) maximum.
- (F) Slopes greater than 8/12 up to a 21/12 (33.7° up to 60°) pitch.

**NOTES:** In addition to the above limits, rooms requiring this type of installation must be hydraulically calculated to supply a minimum of three operating sprinklers. Layout similar for horizontal sidewall sprinklers with throw across slope. Refer to the appropriate residential sprinkler technical data sheets.





TECHNICAL DATA

FREEDOM® RESIDENTIAL  
SPRINKLER  
INSTALLATION GUIDE

The Viking Corporation, 210 N Industrial Park Drive, Hastings MI 49058  
Telephone: 269-945-9501 Technical Services: 877-384-5464 Fax: 269-818-1680 Email: techsvcs@vikingcorp.com

**SPACING OF RESIDENTIAL SPRINKLERS BELOW CEILINGS WITH SLOPES EXCEEDING 8/12 (33.7°) PITCH WITH NO BAFFLE AND A MAXIMUM OF 2 SPRINKLERS IN THE ROOM**  
(NOTE: Refer to NFPA 13D or NFPA 13R, and the Authority Having Jurisdiction.)

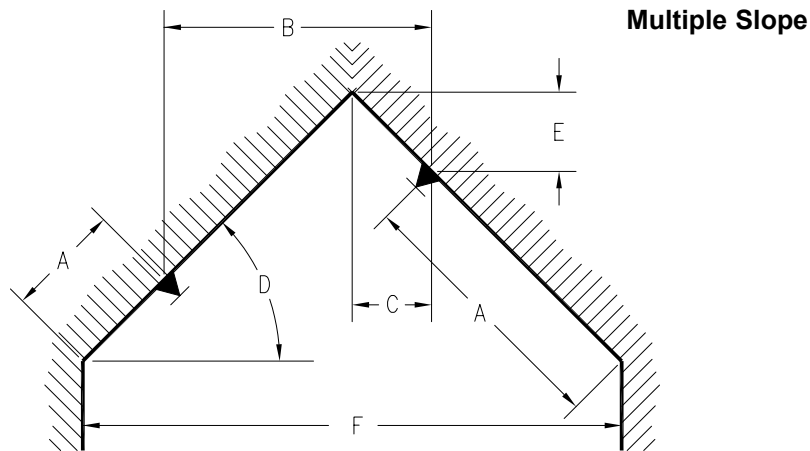

**Figure 7**

- (A) 0'-4" (0-102 mm) minimum, to one-half listed spacing, maximum.
- (B) One-half listed spacing, maximum, 8'-0" (2.4 m) minimum.
- (C) 0'-4" (0-102 mm) minimum.
- (D) Slopes greater than 8/12 pitch up to a 21/12 (33.7° up to a 60°) pitch.
- (E) 3'-0" (.91 m) maximum.
- (F) When dimension "F" exceeds 16' (4.9 m), utilize design configuration shown in Figure 6.

**NOTES:** Layout similar for horizontal sidewall sprinklers with throw across slope. Refer to the appropriate residential sprinkler technical data sheets.

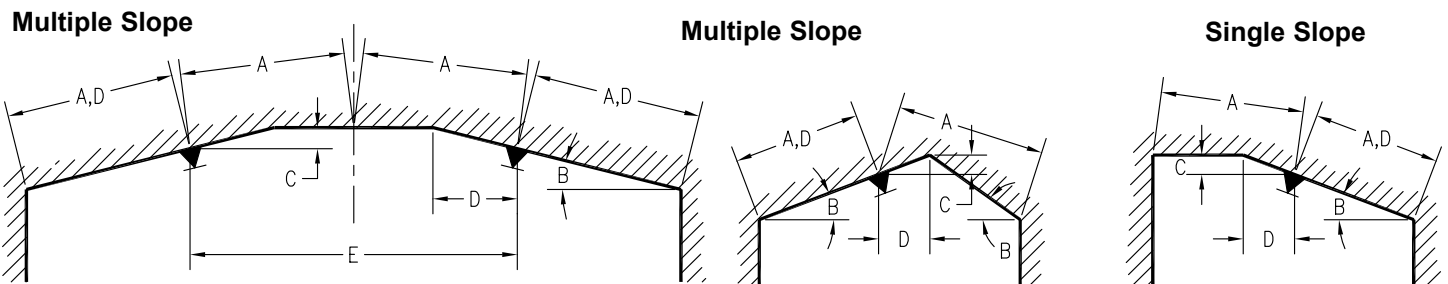

**Figure 8**

- (A) One-half listed spacing, maximum.
- (B) Refer to the appropriate residential sprinkler technical data pages for listings of sprinklers for use below slopes up to and including a 8/12 (33.7°) pitch.
- (C) 3'-0" (.91 m) maximum.
- (D) 0'-4" (0-102 mm) minimum.
- (E) 8'-0" (2.4 m) minimum without baffle.

**NOTES:** Layout similar for horizontal sidewall sprinklers with throw across slope. Refer to the appropriate residential sprinkler technical data sheets.



**TECHNICAL DATA**

**FREEDOM® RESIDENTIAL  
SPRINKLER  
INSTALLATION GUIDE**

The Viking Corporation, 210 N Industrial Park Drive, Hastings MI 49058  
 Telephone: 269-945-9501 Technical Services: 877-384-5464 Fax: 269-818-1680 Email: techsvcs@vikingcorp.com

**MINIMUM DISTANCE BETWEEN SPRINKLER AND INTERSECTING SLOPED CEILINGS**

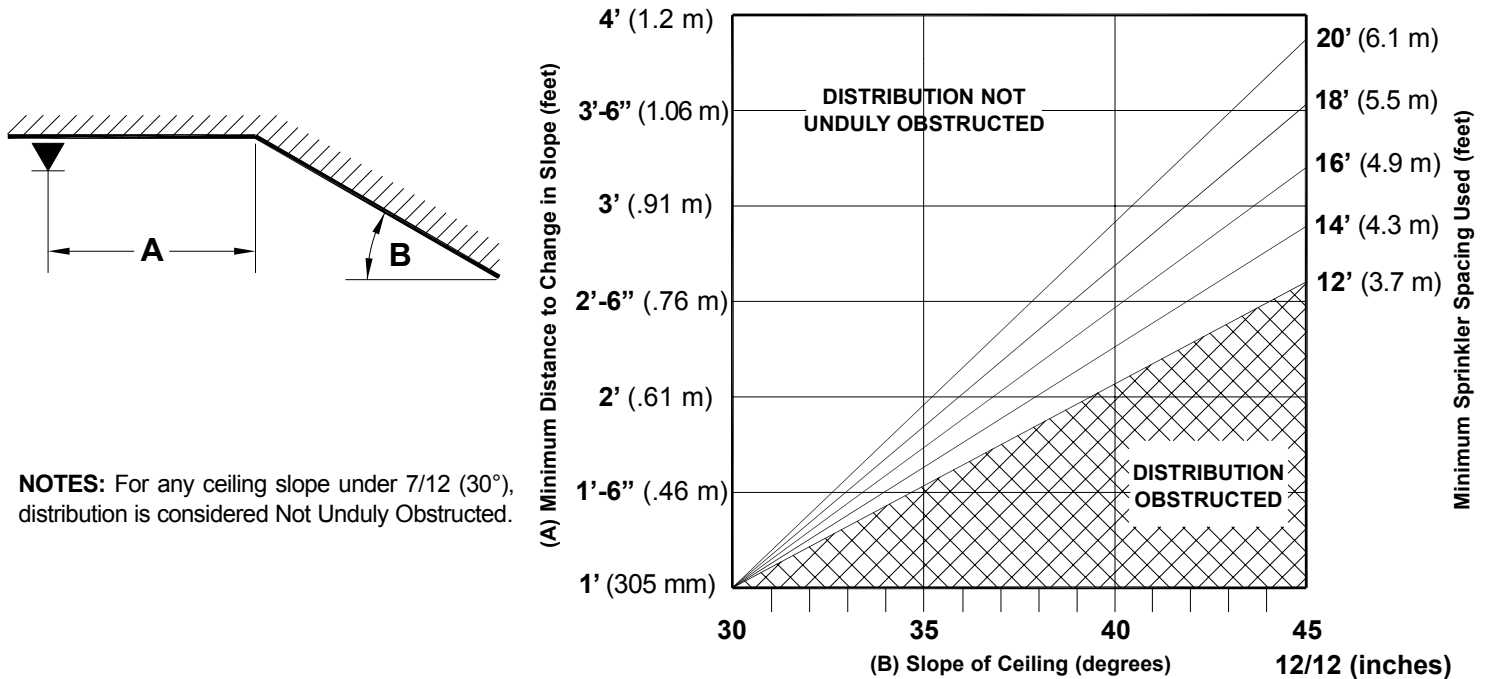

**MAXIMUM DISTANCE DOWN SLOPE TO AVOID OBSTRUCTION TO SPRINKLER DISCHARGE**

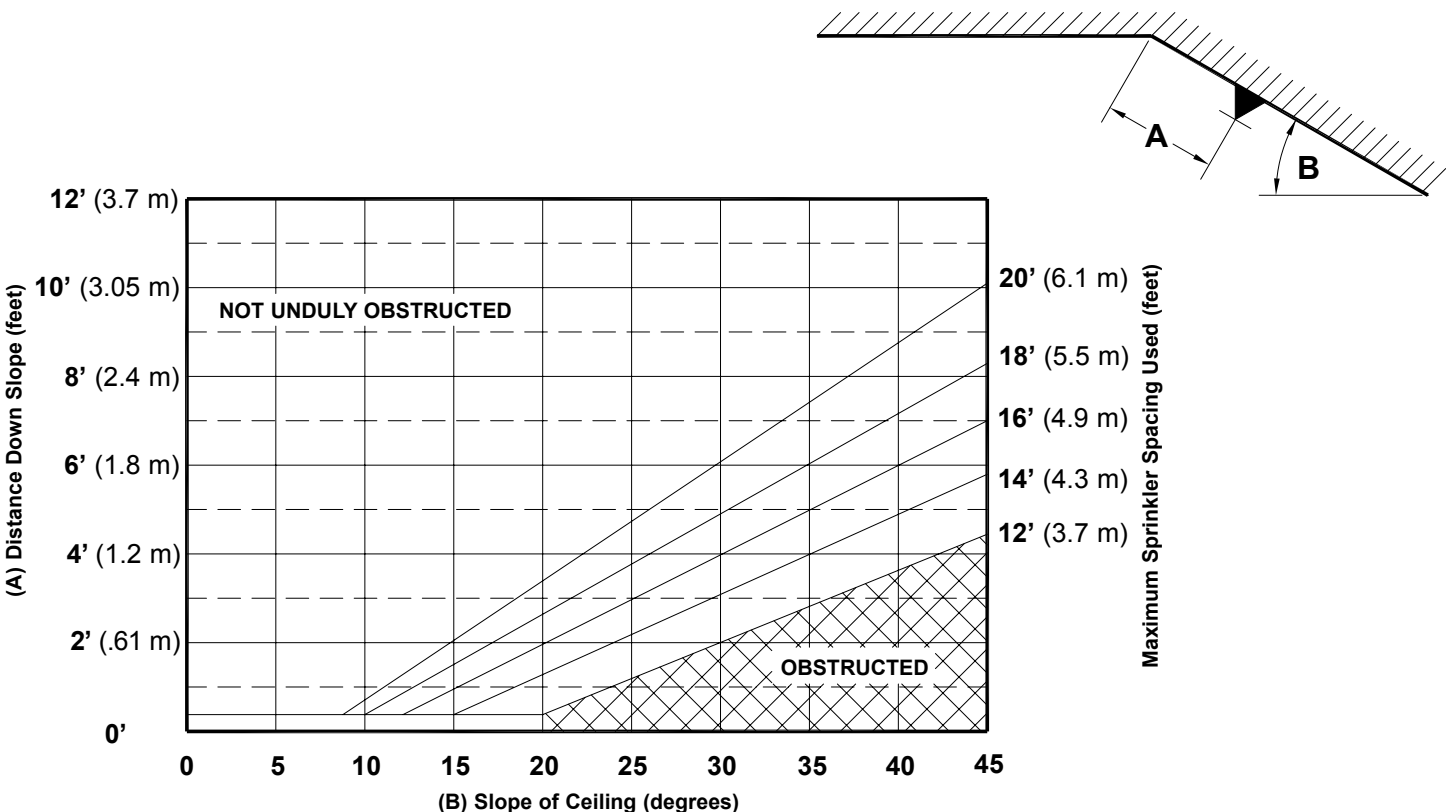



**TECHNICAL DATA**

**FREEDOM® RESIDENTIAL  
SPRINKLER  
INSTALLATION GUIDE**

The Viking Corporation, 210 N Industrial Park Drive, Hastings MI 49058  
 Telephone: 269-945-9501 Technical Services: 877-384-5464 Fax: 269-818-1680 Email: techsvcs@vikingcorp.com

**AVOIDING OBSTRUCTIONS TO SPRINKLER DISCHARGE**

(Obstruction rules for residential sprinklers are found in section 8.10 of the 2010 edition of NFPA 13.)

**Positioning Residential Pendent Sprinklers - Obstructions at the Ceiling**

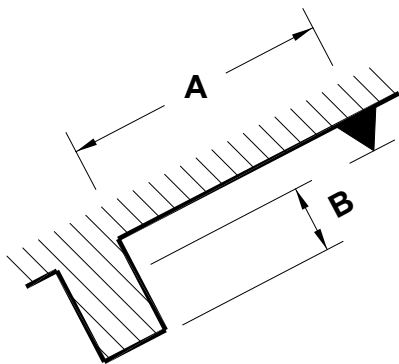
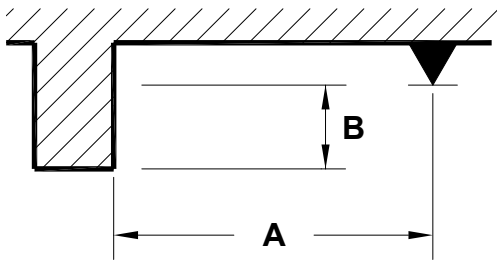

Distance from Sprinkler to Side of Ceiling Obstruction (Dimension A)	Maximum Distance from Deflector to Bottom of Ceiling Obstruction (Dimension B)	
	Inches	mm
Less than 1 ft. 6 in. (Less than 457 mm)	0	0
1 ft. 6 in. to less than 3 ft. (457 mm to less than .94 m)	1	25.4
3 ft. to less than 4 ft. (.91 m to less than 1.2 m)	3	76
4 ft. to less than 4 ft. 6 in. (1.2 m to less than 1.37 m)	5	127
4 ft. 6 in. to less than 6 ft. (1.37 m to less than 1.8 m)	7	178
6 ft. to less than 6 ft. 6 in. (1.8 m to less than 2 m)	9	229
6 ft. 6 in. to less than 7 ft. (2 m to less than 2.1 m)	11	279
7 ft. or greater (2.1 m or greater)	14	356

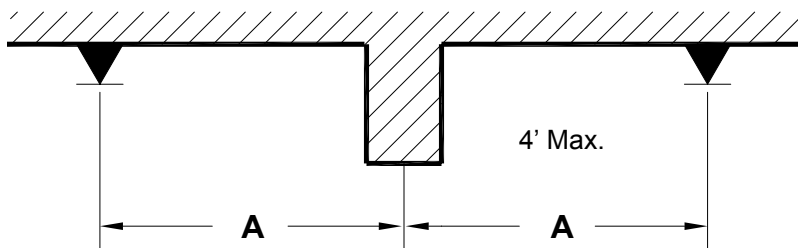

Residential pendent sprinklers may be located on opposite sides of continuous obstructions up to 4 ft. (1.2 m) wide at the ceiling, as long as the distance from the centerline of the obstruction to the sprinklers (A) does not exceed one-half the maximum spacing allowed between sprinklers.

**Positioning Residential Pendent Sprinklers - Obstructions Along Walls**

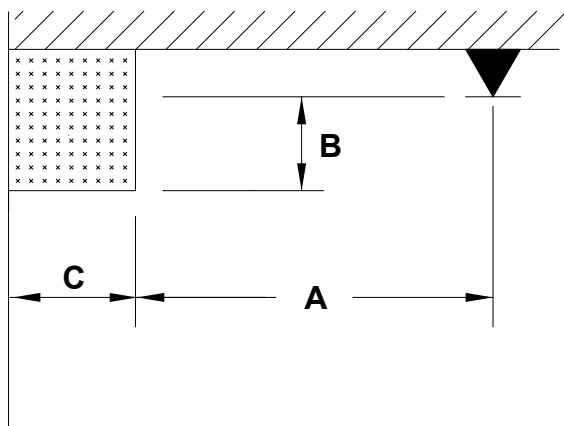

- (A) Distance from centerline of sprinkler to side of obstruction.
- (B) Distance from deflector to bottom of obstruction.
- (C) Width of the obstruction.

Obstructions up to 30 in. (.8 m) wide (C) located against the wall are permitted to be protected when (A) is greater than or equal to (C) minus 8 in. (.2 m) plus (B).

$$C \leq 30 \text{ in.} \quad \text{for metric } C \leq .8 \text{ m}$$

$$A \geq (C - 8 \text{ in.}) + B \quad A \geq (C - .2 \text{ m}) + B$$

	<b>TECHNICAL DATA</b>	<b>FREEDOM® RESIDENTIAL SPRINKLER INSTALLATION GUIDE</b>
---	-----------------------	--

The Viking Corporation, 210 N Industrial Park Drive, Hastings MI 49058  
 Telephone: 269-945-9501 Technical Services: 877-384-5464 Fax: 269-818-1680 Email: techsvcs@vikingcorp.com

**AVOIDING OBSTRUCTIONS TO SPRINKLER DISCHARGE**

(Obstruction rules for residential sprinklers are found in section 8.10 of the 2010 edition of NFPA 13.)

**Positioning Residential Horizontal Sidewall Sprinklers - Obstructions at the Ceiling**

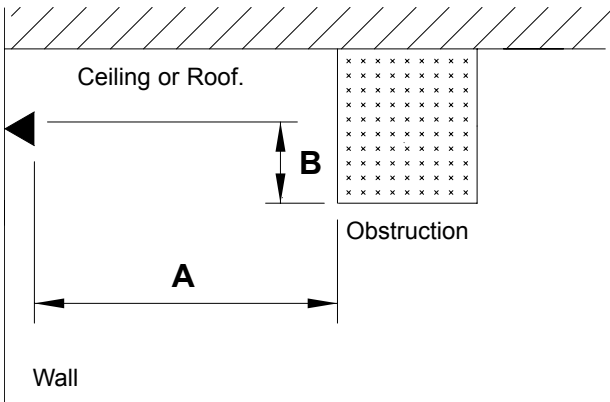

(A) Distance from sprinkler to side of obstruction.  
 (B) Distance from deflector to bottom of obstruction.

Distance from Sprinkler to Side of Ceiling Obstruction (Dimension A)	Maximum Distance from Deflector to Bottom of Ceiling Obstruction (Dimension B)	
	Inches	mm
Less than 8 ft. (Less than 2.4 m)	No Obstructions Allowed	
8 ft. to less than 10 ft. (2.4 m to less than 3.05 m)	1	25.4
10 ft. to less than 11 ft. (3.05 m to less than 3.35 m)	2	50.8
11 ft. to less than 12 ft. (3.35 m to less than 3.7 m)	3	76
12 ft. to less than 13 ft. (3.7 m to less than 4 m)	4	102
13 ft. to less than 14 ft. (4 m to less than 4.3 m)	6	152
14 ft. to less than 15 ft. (4.3 m to less than 4.6 m)	7	178
15 ft. to less than 16 ft. (4.6 m to less than 4.9 m)	9	229
16 ft. to less than 17 ft. (4.9 m to less than 5.2 m)	11	279
17 ft. or greater (5.2 m or greater)	14	356

**Positioning Residential Horizontal Sidewall Sprinklers - Obstructions Along Walls**

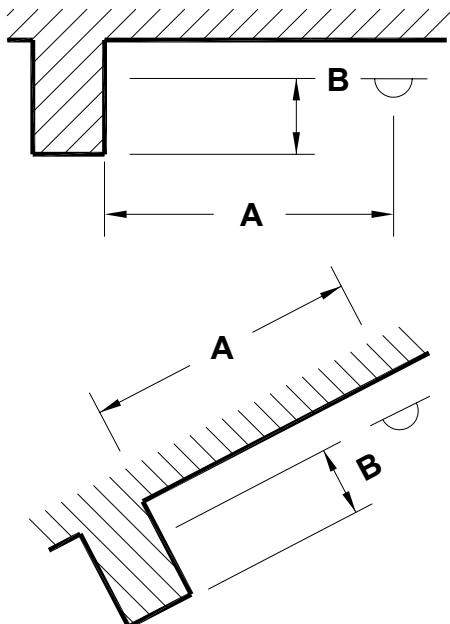

Distance from Sprinkler to Side of Obstruction Along Wall (Dimension A)	Maximum Distance from Deflector to Bottom of Obstruction (Dimension B)	
	Inches	mm
Less than 1 ft. 6 in. (Less than 457 mm)	0	0
1 ft. 6 in. to less than 3 ft. (457 mm to less than .94 m)	1	25.4
3 ft. to less than 4 ft. (.91 m to less than 1.2 m)	3	76
4 ft. to less than 4 ft. 6 in. (1.2 m to less than 1.37 m)	5	127
4 ft. 6 in. to less than 6 ft. (1.37 m to less than 1.8 m)	7	178
6 ft. to less than 6 ft. 6 in. (1.8 m to less than 2 m)	9	229
6 ft. 6 in. to less than 7 ft. (2 m to less than 2.1 m)	11	279
7 ft. or greater (2.1 m or greater)	14	356

(A) Distance from sprinkler to side of obstruction.  
 (B) Distance from deflector to bottom of obstruction.



## TECHNICAL DATA

## FREEDOM® RESIDENTIAL SPRINKLER INSTALLATION GUIDE

The Viking Corporation, 210 N Industrial Park Drive, Hastings MI 49058

Telephone: 269-945-9501 Technical Services: 877-384-5464 Fax: 269-818-1680 Email: techsvcs@vikingcorp.com

### LOCATING RESIDENTIAL SPRINKLERS NEAR HEAT SOURCES

Ordinary temperature rated residential sprinklers (135 °F to 170 °F rated) are only to be installed where the maximum ambient ceiling temperature will not exceed 100 °F. Where the maximum ambient ceiling temperature will be from 101 °F to 150 °F, use intermediate temperature rated residential sprinklers (175 °F to 225 °F rated).

Residential sprinklers must be positioned a sufficient distance away from heat sources that include fireplaces, stoves, kitchen ranges, wall ovens, hot water pipes, water heaters, furnaces and associated flues and ducts, and light fixtures. The following minimum distances must be maintained for both ordinary and intermediate temperature rated residential sprinklers as indicated.

Heat Source	Minimum Distance from Edge of Source to Ordinary Temperature Rated Sprinkler		Minimum Distance from Edge of Source to Intermediate Temperature Rated Sprinkler	
	Inches	metric	Inches	metric
Side of open or recessed fireplace	36	.91 m	12	305 mm
Front of recessed fire place	60	1.5 m	36	.91 m
Coal- or wood-burning stove	42	1.1 m	12	305 mm
Kitchen range	18	457 mm	9	229 mm
Wall oven	18	457 mm	9	229 mm
Hot air flues	18	457 mm	9	229 mm
Uninsulated heat ducts	18	457 mm	9	229 mm
Uninsulated hot water pipes	12	305 mm	6	152 mm
Side of ceiling- or wall-mounted hot air diffusers	24	.61 m	12	305 mm
Front of wall-mounted hot air diffusers	36	.91 m	18	457 mm
Hot water heater or furnace	6	152 mm	3	76 mm
Light fixture less than 250W	6	152 mm	3	76 mm
Light fixture 250W to 499W	12	305 mm	6	152 mm
Where residential sprinklers will be exposed to the rays of the sun passing through glass or plastic skylights, use intermediate temperature rated sprinklers.				
When locating residential sprinklers in an unventilated concealed compartment, under an unventilated attic or uninsulated roof, where the maximum ambient temperature does not exceed 150 °F, use intermediate temperature rated sprinklers.				



**TECHNICAL DATA**

**FREEDOM® RESIDENTIAL  
SPRINKLER  
INSTALLATION GUIDE**

The Viking Corporation, 210 N Industrial Park Drive, Hastings MI 49058

Telephone: 269-945-9501 Technical Services: 877-384-5464 Fax: 269-818-1680 Email: techsvcs@vikingcorp.com

**NOTE:** The dimensions shown are intended to apply to residential sprinklers installed in ceilings above fireplaces used to burn products that cause elevated temperatures at or near the ceiling in areas surrounding the fireplace. The recommendations should not be construed to apply to decorative non-opening fireplaces such as gas fire units that will not cause elevated temperatures at the ceiling.

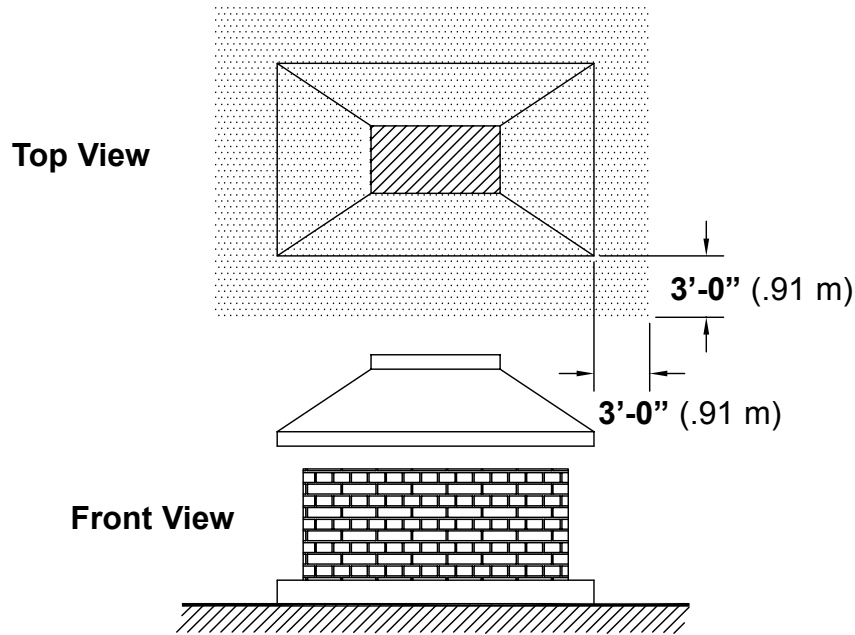

Sprinklers near an open hearth fireplace must be located outside of the shaded area or be intermediate degree rated.

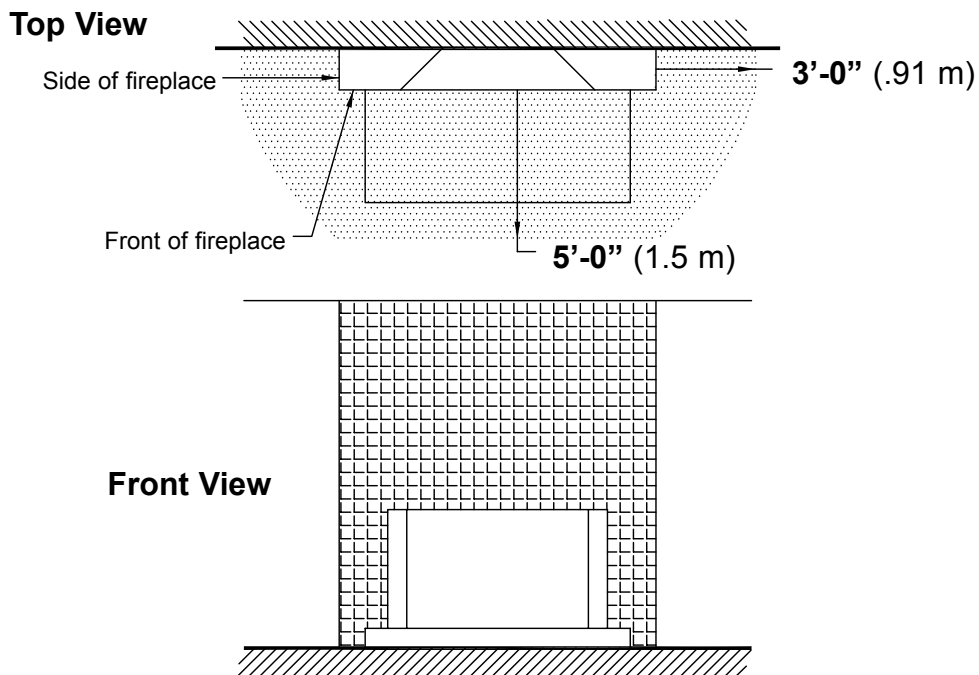

Sprinklers near a recessed hearth fireplace must be located outside of the shaded area [at least 3'-0" (.91 m)] from the side of a recessed fireplace and at least 5'-0" (1.5 m) from the front) or be intermediate degree rated.



**TECHNICAL DATA**

**FREEDOM® RESIDENTIAL  
SPRINKLER  
INSTALLATION GUIDE**

The Viking Corporation, 210 N Industrial Park Drive, Hastings MI 49058  
 Telephone: 269-945-9501 Technical Services: 877-384-5464 Fax: 269-818-1680 Email: techsvcs@vikingcorp.com

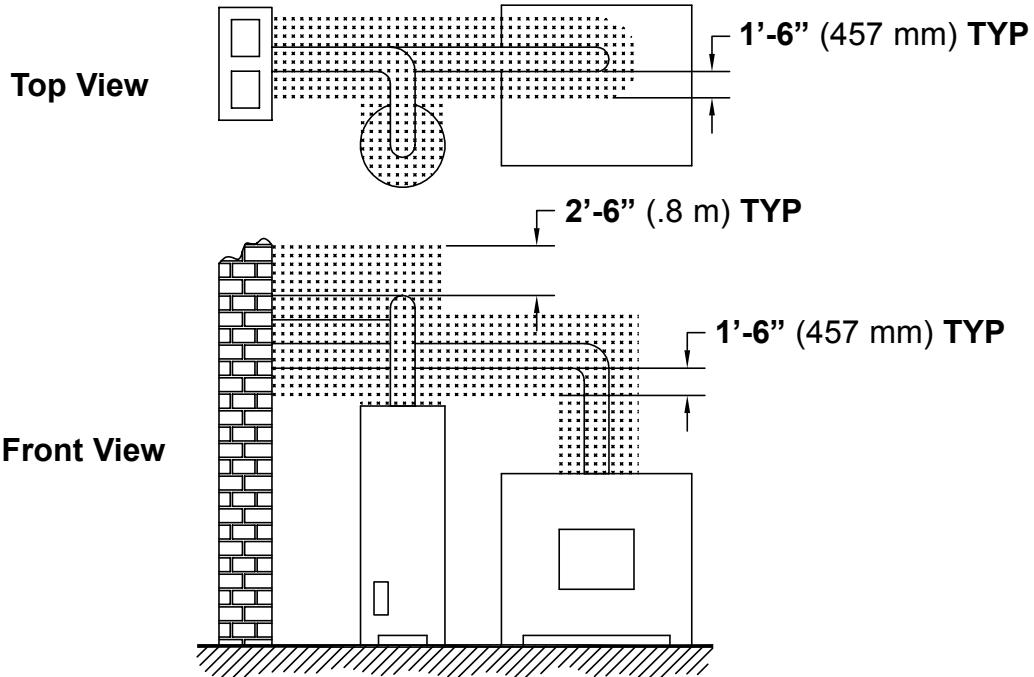

Sprinklers near a furnace or water heater must be located outside of the shaded area or be intermediate degree rated.

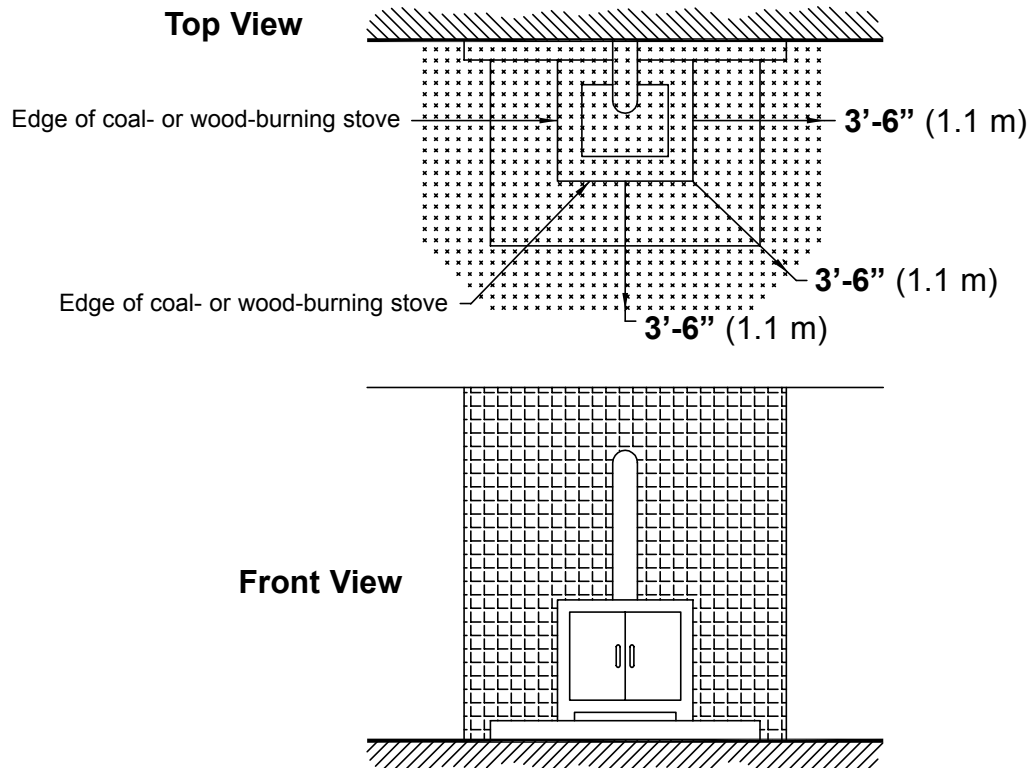

Sprinklers near a coal- or wood-burning stove must be located outside of shaded area or be intermediate degree rated.



TECHNICAL DATA

FREEDOM® RESIDENTIAL  
SPRINKLER  
INSTALLATION GUIDE

The Viking Corporation, 210 N Industrial Park Drive, Hastings MI 49058  
Telephone: 269-945-9501 Technical Services: 877-384-5464 Fax: 269-818-1680 Email: techsvcs@vikingcorp.com

Top View

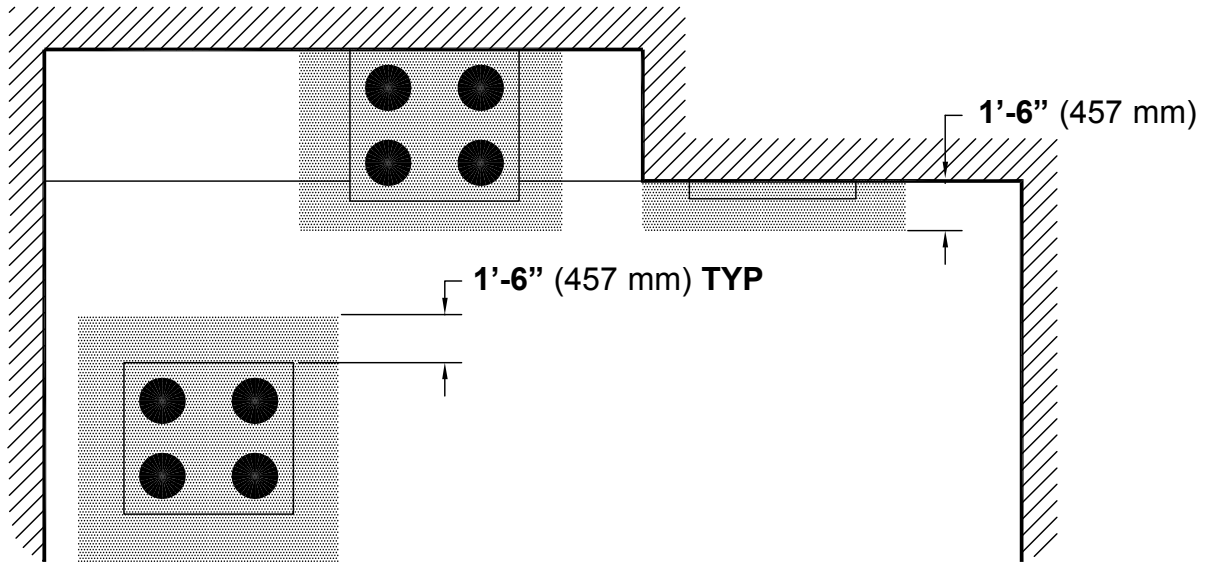

Front View

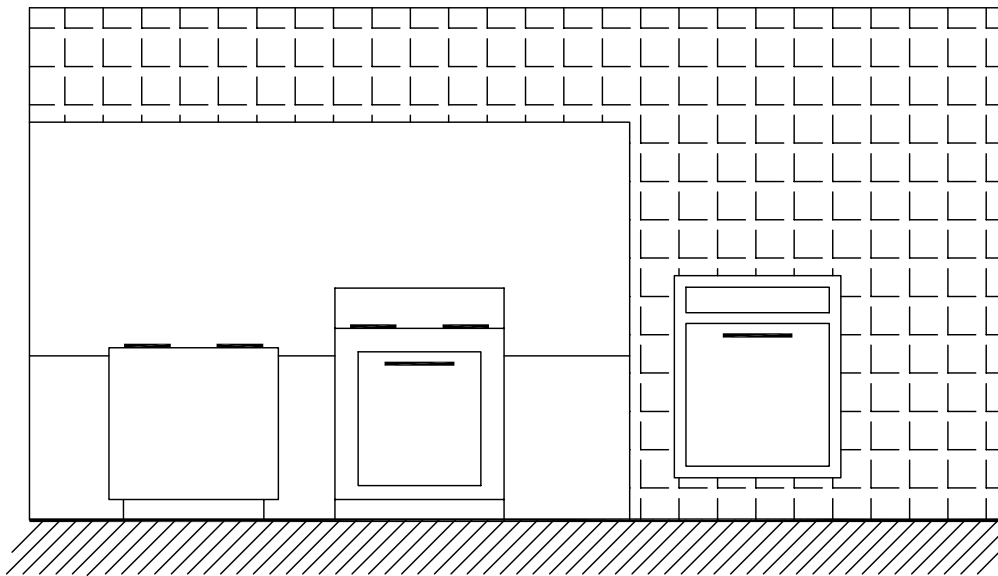

Sprinklers near a range or wall oven must be located outside of shaded areas or be intermediate degree rated.





## BULLETIN

CARE AND HANDLING  
OF SPRINKLERS

The Viking Corporation, 210 N Industrial Park Drive, Hastings MI 49058  
 Telephone: 269-945-9501 Technical Services: 877-384-5464 Fax: 269-818-1680 Email: techsvcs@vikingcorp.com

## SPRINKLERS ARE FRAGILE - HANDLE WITH CARE!

### General Handling and Storage:

- Store sprinklers in a cool, dry place.
- Protect sprinklers during storage, transport, handling, and after installation.
- Use the original shipping containers. DO NOT place sprinklers loose in boxes, bins, or buckets.
- Keep sprinklers separated at all times. DO NOT allow metal parts to contact sprinkler operating elements.

### For Pre-Assembled Drops:

- Protect sprinklers during handling and after installation.
- For recessed assemblies, use the protective sprinkler cap (Viking Part Number 10364).

### Sprinklers with Protective Shields or Caps:

- DO NOT remove shields or caps until after sprinkler installation and there no longer is potential for mechanical damage to the sprinkler operating elements.
- **Sprinkler shields or caps MUST be removed BEFORE placing the system in service!**
- Remove the sprinkler shield by carefully pulling it apart where it is snapped together.
- Remove the cap by turning it slightly and pulling it off the sprinkler.

### Sprinkler Installation:

- DO NOT use the sprinkler deflector or operating element to start or thread the sprinkler into a fitting.
- **Use only the designated sprinkler head wrench!** Refer to the current sprinkler technical data page to determine the correct wrench for the model of sprinkler used.
- DO NOT install sprinklers onto piping at the floor level.
- Install sprinklers after the piping is in place to prevent mechanical damage.
- DO NOT allow impacts such as hammer blows directly to sprinklers or to fittings, pipe, or couplings in close proximity to sprinklers. Sprinklers can be damaged from direct or indirect impacts.
- DO NOT attempt to remove drywall, paint, etc., from sprinklers.
- **Take care not to over-tighten the sprinkler and/or damage its operating parts!**

#### Maximum Torque:

1/2" NPT: 14 ft-lbs. (19.0 N-m)

3/4" NPT: 20 ft-lbs. (27.1 N-m)

1" NPT: 30 ft-lbs. (40.7 N-m)



**CORRECT**  
(Original container used)

**INCORRECT**  
(Placed loose in box)



**CORRECT**  
(Protected with caps)

**INCORRECT**  
(Protective caps not used)



**CORRECT**  
(Piping is in place at the ceiling)

**INCORRECT**  
(Sprinkler at floor level)



**CORRECT**  
(Special installation wrenches)

**INCORRECT**  
(Designated wrench not used)



**WARNING:** Cancer and Reproductive Harm-  
[www.P65Warnings.ca.gov](http://www.P65Warnings.ca.gov)

### **! WARNING**

Any sprinkler with a loss of liquid from the glass bulb or damage to the fusible element should be destroyed. Never install sprinklers that have been dropped, damaged, or exposed to temperatures exceeding the maximum ambient temperature allowed. Sprinklers that have been painted in the field must be replaced per NFPA 13. Protect sprinklers from paint and paint overspray in accordance with the installation standards. Do not clean sprinklers with soap and water, ammonia, or any other cleaning fluid. Do not use adhesives or solvents on sprinklers or their operating elements.

**Refer to the appropriate technical data page and NFPA standards for complete care, handling, installation, and maintenance instructions. For additional product and system information Viking data pages and installation instructions are available on the Viking Web site at [www.vikinggroupinc.com](http://www.vikinggroupinc.com).**



## BULLETIN

CARE AND HANDLING  
OF SPRINKLERS

The Viking Corporation, 210 N Industrial Park Drive, Hastings MI 49058  
 Telephone: 269-945-9501 Technical Services: 877-384-5464 Fax: 269-818-1680 Email: techsvcs@vikingcorp.com

## PROTECTIVE SPRINKLER SHIELDS AND CAPS

### General Handling and Storage:

Many Viking sprinklers are available with a plastic protective cap or shield temporarily covering the operating elements. The snap-on shields and caps are factory installed and are intended to help protect the operating elements from mechanical damage during shipping, storage, and installation. NOTE: It is still necessary to follow the care and handling instructions on the appropriate sprinkler technical data sheets\* when installing sprinklers with bulb shields or caps.

### WHEN TO REMOVE THE SHIELDS AND CAPS:

NOTE: SHIELDS AND CAPS MUST BE REMOVED FROM SPRINKLERS BEFORE PLACING THE SYSTEM IN SERVICE!

Remove the shield or cap from the sprinkler only after checking all of the following:

- The sprinkler has been installed\*.
- The wall or ceiling finish work is completed where the sprinkler is installed and there no longer is a potential for mechanical damage to the sprinkler operating elements.

**SHIELDS AND CAPS MUST BE REMOVED FROM SPRINKLERS BEFORE PLACING THE SYSTEM IN SERVICE!**



Figure 1: Sprinkler shield being removed from a pendent sprinkler.



Figure 2: Sprinkler cap being removed from a pendent sprinkler.



Figure 3: Sprinkler cap being removed from an upright sprinkler.

## HOW TO REMOVE SHIELDS AND CAPS:

No tools are necessary to remove the shields or caps from sprinklers. DO NOT use any sharp objects to remove them! **Take care not to cause mechanical damage to sprinklers when removing the shields or caps.** When removing caps from fusible element sprinklers, use care to prevent dislodging ejector springs or damaging fusible elements. NOTE: Squeezing the sprinkler cap excessively could damage sprinkler fusible elements.

- To remove the shield, simply pull the ends of the shield apart where it is snapped together. Refer to Figure 1.
- To remove the cap, turn it slightly and pull it off the sprinkler. Refer to Figures 2 and 3.

### NOTICE

Refer to the current sprinkler technical data page to determine the correct sprinkler wrench for the model of sprinkler used.

### WARNING

Never install sprinklers that have been dropped, damaged, or exposed to temperatures in excess of the maximum ambient temperature allowed.

\* Refer to the appropriate current technical data pages for complete care, handling, and installation instructions. Data pages are included with each shipment from Viking or Viking distributors. They can also be found on the Web site at [www.vikinggroupinc.com](http://www.vikinggroupinc.com).



## BULLETIN

CARE AND HANDLING  
OF SPRINKLERS

The Viking Corporation, 210 N Industrial Park Drive, Hastings MI 49058  
 Telephone: 269-945-9501 Technical Services: 877-384-5464 Fax: 269-818-1680 Email: techsvcs@vikingcorp.com



**CONCEALED COVER ASSEMBLIES ARE FRAGILE!**  
**TO ASSURE SATISFACTORY PERFORMANCE OF THE PRODUCT, HANDLE WITH CARE.**



Concealed Sprinkler and Adapter  
 Assembly with Protective Cap

Concealed Sprinkler and Adapter  
 Assembly (Protective Cap Removed)



Cover Plate Assembly  
 (Pendent Cover 12381 shown)



#### GENERAL HANDLING AND STORAGE INSTRUCTIONS:

- Do not store in temperatures exceeding 100 °F (38 °C). Avoid direct sunlight and confined areas subject to heat.
- Protect sprinklers and cover assemblies during storage, transport, handling, and after installation.
  - Use original shipping containers.
  - Do not place sprinklers or cover assemblies loose in boxes, bins, or buckets.
- Keep the sprinkler bodies covered with the protective sprinkler cap any time the sprinklers are shipped or handled, during testing of the system, and while ceiling finish work is being completed.
- Use only the designated Viking recessed sprinkler wrench (refer to the appropriate sprinkler data page) to install these sprinklers. **NOTE:** The protective cap is temporarily removed during installation and then placed back on the sprinkler for protection until finish work is completed.
- Do not over-tighten the sprinklers into fittings during installation.
- Do not use the sprinkler deflector to start or thread the sprinklers into fittings during installation.
- Do not attempt to remove drywall, paint, etc., from the sprinklers.
- Remove the plastic protective cap from the sprinkler before attaching the cover plate assembly. **PROTECTIVE CAPS MUST BE REMOVED FROM SPRINKLERS BEFORE PLACING THE SYSTEM IN SERVICE!**

Refer to the appropriate current technical data pages for complete care, handling, and installation instructions. Data pages are included with each shipment from Viking or Viking distributors. They can also be found on the Web site at [www.vikinggroupinc.com](http://www.vikinggroupinc.com).



## BULLETIN

CARE AND HANDLING  
OF SPRINKLERS

The Viking Corporation, 210 N Industrial Park Drive, Hastings MI 49058

Telephone: 269-945-9501 Technical Services: 877-384-5464 Fax: 269-818-1680 Email: techsvcs@vikingcorp.com

## USE THE FOLLOWING PRECAUTIONS WHEN HANDLING WAX-COATED SPRINKLERS

Many of Viking's sprinklers are available with factory-applied wax coating for corrosion resistance. These sprinklers MUST receive appropriate care and handling to avoid damaging the wax coating and to assure satisfactory performance of the product.

### General Handling and Storage of Wax-Coated Sprinklers:

- Store the sprinklers in a cool, dry place (in temperatures below the maximum ambient temperature allowed for the sprinkler temperature rating. Refer to Table 1 below.)
- Store containers of wax-coated sprinklers separate from other sprinklers.
- Protect the sprinklers during storage, transport, handling, and after installation.
- Use original shipping containers.
- Do not place sprinklers in loose boxes, bins, or buckets.

### Installation of Wax-Coated Sprinklers:

Use only the special sprinkler head wrench designed for installing wax-coated Viking sprinklers (any other wrench may damage the unit).

- Take care not to crack the wax coating on the units.
- For touching up the wax coating after installation, wax is available from Viking in bar form. Refer to Table 1 below. The coating MUST be repaired after sprinkler installation to protect the corrosion-resistant properties of the sprinkler.
- Use care when locating sprinklers near fixtures that can generate heat. Do not install sprinklers where they would be exposed to temperatures exceeding the maximum recommended ambient temperature for the temperature rating used.
- Inspect the coated sprinklers frequently soon after installation to verify the integrity of the corrosion resistant coating. Thereafter, inspect representative samples of the coated sprinklers in accordance with NFPA 25. Close up visual inspections are necessary to determine whether the sprinklers are being affected by corrosive conditions.

TABLE 1

Sprinkler Temperature Rating (Fusing Point)	Wax Part Number	Wax Melting Point	Maximum Ambient Ceiling Temperature <sup>1</sup>	Wax Color
155 °F (68 °C) / 165 °F (74 °C)	02568A	148 °F (64 °C)	100 °F (38 °C)	Light Brown
175 °F (79 °C)	04146A	161 °F (71 °C)	150 °F (65 °C)	Brown
200 °F (93 °C)	04146A	161 °F (71 °C)	150 °F (65 °C)	Brown
220 °F (104 °C)	02569A	170 °F (76 °C)	150 °F (65 °C)	Dark Brown
286 °F (141 °C)	02569A	170 °F (76 °C)	150 °F (65 °C)	Dark Brown

<sup>1</sup> Based on NFPA-13. Other limits may apply, depending on fire loading, sprinkler location, and other requirements of the Authority Having Jurisdiction. Refer to specific installation standards.



Never install sprinklers that have been dropped, damaged, or exposed to temperatures in excess of the maximum ambient temperature allowed.

Refer to the appropriate current technical data pages for complete care, handling, and installation instructions. Data pages are included with each shipment from Viking or Viking distributors. They can also be found on the Web site at [www.vikinggroupinc.com](http://www.vikinggroupinc.com).



## TECHNICAL DATA

## SPRINKLER OVERVIEW

The Viking Corporation, 210 N Industrial Park Drive, Hastings MI 49058

Telephone: 269-945-9501 Technical Services: 877-384-5464 Fax: 269-818-1680 Email: techsvcs@vikingcorp.com

### 1. DESCRIPTION

Viking fire sprinklers consist of a threaded frame with a specific waterway or orifice size and a deflector for distributing water in a specified pattern. A closed or sealed sprinkler refers to a complete assembly, including the thermosensitive operating element. An open sprinkler does not use an operating element and is open at all times. The distribution of water is intended to extinguish a fire or to control its spread.

Viking sprinklers are available in several models and styles. Refer to specific sprinkler technical data pages for available styles, finishes, temperature ratings, thread sizes, and nominal K-Factors for the particular model selected.

### 2. LISTINGS AND APPROVALS

Refer to the Approval Charts on the appropriate sprinkler technical data page(s) and/or approval agency listings.



**WARNING:** Cancer and Reproductive Harm-  
www.P65Warnings.ca.gov

### 3. TECHNICAL DATA

#### Pressure Ratings:

Maximum allowable water working pressure is 175 psig (12 Bar) unless rated and specified for high water working pressure [250 psig (17.2 bar)].

#### Sprinkler Identification:

Viking sprinklers are identified and marked with the word "Viking", the sprinkler identification number (SIN) consisting of "VK" plus a three digit number\*, the model letter, and the year of manufacture.

#### Available Finishes:

Viking sprinklers are available in several decorative finishes. Some models are available with corrosion-resistant coatings or are fabricated from non-corrosive material. Refer to the sprinkler technical data page for additional information.

#### Available Temperature Ratings:

Viking sprinklers are available in several temperature ratings that relate to a specific temperature classification. Applicable installation rules mandate the use and limitations of each temperature classification. In selecting the appropriate temperature classification, the maximum expected ceiling temperature must be known. When there is doubt as to the maximum temperature at the sprinkler location, a maximum-reading thermometer should be used to determine the temperature under conditions that would show the highest readings to be expected. In addition, recognized installation rules may require a higher temperature classification, depending upon sprinkler location, occupancy classification, commodity classification, storage height, and other hazards. In all cases, the maximum expected ceiling temperature dictates the lowest allowable temperature classification. Sprinklers located immediately adjacent to a heat source may require a higher temperature rating.

#### K-Factors:

Viking sprinklers are available in several orifice sizes with related K-Factors. The orifice is a tapered waterway and, therefore, the K-Factor given is nominal. Nominal U.S. K-Factors are provided in accordance with the 1999 edition of NFPA 13, Section 3-2.3. Refer to the specific data page for appropriate K-Factor information.

#### Available Styles:

Viking sprinklers are available for installation in several positions as indicated by a stamping on the deflector. The deflector style dictates the appropriate installation position of the sprinkler; it breaks the solid stream of water issuing from the sprinkler orifice to form a specific spray pattern. The following list indicates the various styles and identification of Viking sprinklers.

**UPRIGHT SPRINKLER:** A sprinkler intended to be installed with the deflector above the frame so water flows upward through the orifice, striking the deflector and forming an umbrella-shaped spray pattern downward. Marked "SSU" (Standard Sprinkler Upright) or "UPRIGHT" on the deflector.

**PENDENT SPRINKLER:** A sprinkler intended to be oriented with the deflector below the frame so water flows downward through the orifice, striking the deflector and forming an umbrella-shaped spray pattern downward. Marked "SSP" (Standard Sprinkler Pendent) or "PENDENT" on the deflector.

**CONVENTIONAL SPRINKLER:** An "old style" sprinkler intended to be installed with the deflector in either the upright or pendent position. The deflector provides a spherical type pattern with 40 to 60 percent of the water initially directed downward and a proportion directed upward. Must be installed in accordance with installation rules for conventional or old style sprinklers. **DO NOT USE AS A REPLACEMENT FOR STANDARD SPRAY SPRINKLERS.** Marked "C U/P" (Conventional Upright/Pendent) on the deflector.

Viking Technical Data may be found on  
The Viking Corporation's Web site at  
<http://www.vikinggroupinc.com>.  
The Web site may include a more recent  
edition of this Technical Data Page.



## TECHNICAL DATA

## SPRINKLER OVERVIEW

The Viking Corporation, 210 N Industrial Park Drive, Hastings MI 49058

Telephone: 269-945-9501 Technical Services: 877-384-5464 Fax: 269-818-1680 Email: techsvcs@vikingcorp.com

**VERTICAL SIDEWALL (VSW) SPRINKLER:** A sprinkler intended for installation near the wall and ceiling. The deflector provides a water spray pattern outward in a quarter-spherical pattern and can be installed in the upright or pendent position with the flow arrow in the direction of discharge. Marked "SIDEWALL" on the deflector with an arrow and the word "FLOW". (Note: Some vertical sidewall sprinklers can only be installed in the upright or pendent position—in this case, the sprinkler will also be marked "UPRIGHT" or "PENDENT".)

**HORIZONTAL SIDEWALL (HSW) SPRINKLER:** A sprinkler intended for installation near the wall and ceiling. The special deflector provides a water spray pattern outward in a quarter-spherical pattern. Most of the water is directed away from the nearby wall with a small portion directed at the wall behind the sprinkler. The top of the deflector is oriented parallel with the ceiling or roof. The flow arrows point in the direction of discharge. Marked "SIDEWALL" and "TOP" with an arrow and the word "FLOW".

**EXTENDED COVERAGE (EC) SPRINKLER:** A spray sprinkler designed to discharge water over an area having the maximum dimensions indicated in the individual listings. Maximum area of coverage, minimum flow rate, orifice size, and nominal K-Factor are specified in the individual listings. EC sprinklers are intended for Light-Hazard occupancies with smooth, flat, horizontal ceilings unless otherwise specified. In addition to the above markings, the sprinkler is marked "EC".

**QUICK RESPONSE (QR) SPRINKLER:** A spray sprinkler with a fast-actuating operating element. The use of quick response sprinklers may be limited due to occupancy and hazard. Refer to the Authority Having Jurisdiction (AHJ) prior to installing.

**QUICK RESPONSE EXTENDED COVERAGE (QREC) SPRINKLER:** A spray sprinkler designed to discharge water over an area having the maximum dimensions indicated in the individual listing. This is a sprinkler with an operating element that meets the criteria for quick response. QREC sprinklers are only intended for Light Hazard occupancies. The sprinkler is marked "QREC".

**FLUSH SPRINKLER:** A decorative spray sprinkler intended for installation with a concealed piping system. The unit is mounted flush with the ceiling or wall, with the fusible link exposed. Upon actuation, the deflector extends beyond the ceiling or wall to distribute water discharge. The sprinkler is marked "SSP", "PEND", or "SIDEWALL" and "TOP".

**CONCEALED SPRINKLER:** A decorative spray sprinkler intended for installation with a concealed piping system. The sprinkler is hidden from view by a cover plate installed flush with the ceiling or wall. During fire conditions, the cover plate detaches, and upon sprinkler actuation, the deflector extends beyond the ceiling or wall to distribute water discharge. The sprinkler is marked "SSP", "PEND", or "SIDEWALL" and "TOP".

**RECESSED SPRINKLER:** A spray sprinkler assembly intended for installation with a concealed piping system. The assembly consists of a sprinkler installed in a decorative adjustable recessed escutcheon that minimizes the protrusion of the sprinkler beyond the ceiling or wall without adversely affecting the sprinkler distribution or sensitivity. Refer to the appropriate technical data page for allowable sprinkler models, temperature ratings, and occupancy classifications. DO NOT RECESS ANY SPRINKLER NOT LISTED FOR USE WITH THE ESCUTCHEON.

**CORROSION-RESISTANT SPRINKLER:** A special service sprinkler with non-corrosive protective coatings, or that is fabricated from non-corrosive material, for use in atmospheres that would normally corrode sprinklers.

**DRY SPRINKLER:** A special-service sprinkler intended for installation on dry pipe systems or wet pipe systems where the sprinkler is subject to freezing temperatures. The unit consists of a sprinkler permanently secured to an extension nipple with a sealed inlet end to prevent water from entering the nipple until the sprinkler operates. The unit MUST be installed in a tee fitting. Dry upright sprinklers are marked with the "B" dimension [distance from the face of the fitting (tee) to the top of the deflector]. Dry pendent and sidewall sprinklers are marked with the "A" dimension [the distance from the face of fitting (tee) to the finished surface of the ceiling or wall].

**LARGE DROP SPRINKLER:** A type of special application sprinkler used to provide fire control of specific high-challenge fire hazards. Large drop sprinklers are designed to produce an umbrella-shaped spray pattern downward with a higher percentage of "large" water droplets than standard spray sprinklers. The sprinkler has an extra-large orifice with a nominal K-Factor of 11.2. Marked "HIGH CHALLENGE" and "UPRIGHT".

**EARLY SUPPRESSION FAST-RESPONSE (ESFR) SPRINKLER:** A sprinkler intended to provide fire suppression of specific high-challenge fire hazards through the use of a fast response fusible link, 14.0, 16.8, or 25.2 nominal K-Factor, and special deflector. ESFR sprinklers are designed to produce high-momentum water droplets in a hemispherical pattern below the deflector. This permits penetration of the fire plume and direct wetting of the burning fuel surface while cooling the atmosphere early in the development of a high-challenge fire. Marked "ESFR" and "UPRIGHT" or "PEND".

**INTERMEDIATE LEVEL/RACK STORAGE SPRINKLER:** A standard spray sprinkler assembly designed to protect its operating element from the spray of sprinklers installed at higher elevations. The assembly consists of a standard or large orifice upright or pendent sprinkler with an integral upright or pendent water shield and guard assembly. Use only those sprinklers that have been tested and listed for use with the assembly. Refer to the technical data page for allowable sprinkler models.

**RESIDENTIAL SPRINKLER:** A sprinkler intended for use in the following occupancies: one- and two-family dwellings with the fire protection sprinkler system installed in accordance with NFPA 13D; residential occupancies up to four stories in height with the fire protection system installed in accordance with NFPA 13R; and where allowed by the Authority Having Jurisdiction in residential portions of any occupancy with the fire protection system installed in accordance with NFPA 13.



## TECHNICAL DATA

## SPRINKLER OVERVIEW

The Viking Corporation, 210 N Industrial Park Drive, Hastings MI 49058

Telephone: 269-945-9501 Technical Services: 877-384-5464 Fax: 269-818-1680 Email: techsvcs@vikingcorp.com

Residential sprinklers have a unique distribution pattern and utilize a “fast response” heat sensitive operating element. They enhance survivability in the room of fire origin and are designed to provide a life safety environment for a minimum of ten minutes. For this reason, residential sprinklers must not be used to replace standard sprinklers unless tested for and approved by the Authority Having Jurisdiction. In addition to standard markings, the unit is identified as “RESIDENTIAL SPRINKLER” or “RES”.

#### 4. INSTALLATION

Refer to appropriate NFPA Installation Standards.

#### 5. OPERATION

Refer to the appropriate sprinkler technical data page(s).

#### 6. INSPECTIONS, TESTS AND MAINTENANCE

Refer to NFPA 25 for Inspection, Testing and Maintenance requirements.

#### 7. AVAILABILITY

Viking sprinklers are available through a network of domestic and international distributors. See The Viking Corporation web site for the closest distributor or contact The Viking Corporation.

#### 8. GUARANTEE

For details of warranty, refer to Viking’s current list price schedule or contact Viking directly.

**IMPORTANT: Always refer to Bulletin Form No. F\_091699 - Care and Handling of Sprinklers and the appropriate sprinkler general care, installation, and maintenance guide. Vikings sprinklers are to be installed in accordance with the latest edition of Viking technical data, the appropriate standards of NFPA, FM Global, LPCB, APSAD, VdS or other similar organizations, and also with the provisions of governmental codes, ordinances, and standards, whenever applicable. The sprinkler technical data page may contain installation requirements specific for the sprinkler model selected. The use of certain types of sprinklers may be limited due to occupancy and hazard. Refer to the Authority Having Jurisdiction prior to installation.**



## BULLETIN

### BEST PRACTICES FOR RESIDENTIAL SPRINKLER HANDLING & INSTALLATION

The Viking Corporation, 210 N Industrial Park Drive, Hastings MI 49058  
 Telephone: 269-945-9501 Technical Services: 877-384-5464 Fax: 269-818-1680 Email: techsvcs@vikingcorp.com  
 Visit the Viking website for the latest edition of this technical data page.

### SPRINKLERS ARE FRAGILE - HANDLE WITH CARE!

- Always keep sprinklers in a cool dry place.
- Protect sprinklers during storage, transport and handling as well as before, during and after installation. Refer to Viking's Care and Handling of Sprinklers Bulletin [Form No. F\\_091699<sup>2</sup>](#).
- Proper transit, storage and installation of sprinklers in a high-heat environment is a must. Care should be taken to prevent sprinklers from being exposed to ambient heat conditions in excess of those referenced in installation standards.
- Do not stage or store sprinklers on the job site in advance in a non-conditioned space prior to installation.
- Keep sprinklers in the original packaging and check temperature indicators on box label prior to installation. If the indicator has turned black, DO NOT install any product contained in the box. Refer to Viking product return policies.
- Temperatures exceeding the maximum ambient temperature of the sprinkler temperature-rating during storage, transport, handling and installation must be avoided.
- Per NFPA standards 13, 13R, and 13D, sprinklers installed where maximum ambient temperatures are at or over 101 °F (38 °C ) through 150 °F (66 °C) shall be intermediate temperature-rated sprinklers. Additionally, if sprinklers are installed in an unventilated concealed space under an uninsulated roof or in an unventilated attic, they shall be of intermediate temperature classification.
- Sprinklers installed where ambient temperatures are at or below 100 °F (38 °C) may be either ordinary or intermediate temperature-rated sprinklers. Refer to NFPA standards 13R 6.2.3.1 and 13D 7.5.6.1.
- Rough-in of sprinkler piping during hot weather conditions should not include the installation of sprinklers unless reasonable ambient temperatures can be maintained. Ambient temperatures that are considered when choosing the temperature rating for a sprinkler should take into account the range of ambient temperatures that are expected from installation through establishment and maintenance of temperature in a conditioned space. Appropriate insulation may be considered. **Example:** An ordinary temperature sprinkler should not be exposed to maximum ambient temperature higher than 100 °F (38 °C) or more. Refer to NFPA 13, Table 6.2.5.1, NFPA 13R, 6.2.3.1 and NFPA 13D, 7.5.6.1.
- CPVC fire sprinkler products exposed to high ambient temperatures (e.g. installed in unventilated, concealed spaces such as attics) should be insulated to maintain a cooler environment. Refer to Viking Plastics Installation and Design Manual, [Form No. F\\_080712<sup>2</sup>](#), for care and handling procedures.
- Protect all sprinklers and connecting CPVC piping in attic spaces and unvented concealed spaces from excessive heat exposure above 100 °F (38 °C). To separate excessive attic heat, properly tent and fully insulate all pipe in unconditioned spaces.
- Pressure relief valves should be installed on wet sprinkler systems where there is a risk of over-pressurization of a checked water supply, due to thermal expansion. Refer to NFPA 13, 7.1.2.1 and NFPA 13D, A.5.2.2.2.
- Fire sprinkler systems should be installed per current referenced editions of building codes and installation standards adopted in the jurisdiction where work is being performed.

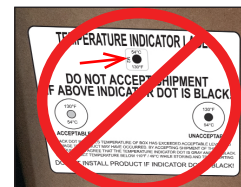

**INCORRECT**  
(Heat exposure)

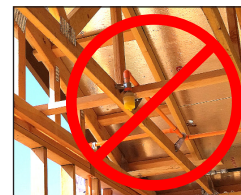

**INCORRECT**  
(Unconditioned at rough-in)



**INCORRECT**  
(Exposed piping)



**INCORRECT**  
(No pressure relief valve)

**WARNING:** Cancer and Reproductive Harm-  
[www.P65Warnings.ca.gov](http://www.P65Warnings.ca.gov)

<sup>1</sup>Hot weather condition is defined as temperatures that can reach the maximum ambient temperature-rating of the sprinkler.

<sup>2</sup>Clicking on blue hyperlink will open referenced document.

#### **▲ WARNING**

Any sprinkler with a loss of liquid from the glass bulb or damage to the fusible element should be destroyed. Never install sprinklers that have been dropped, damaged, or exposed to temperatures exceeding the maximum ambient temperature allowed. Sprinklers that have been painted in the field must be replaced per NFPA 13. Protect sprinklers from paint and paint overspray in accordance with the installation standards. Do not clean sprinklers with soap and water, ammonia, or any other cleaning fluid. Do not use adhesives or solvents on sprinklers or their operating elements.

**Refer to the appropriate technical data page and NFPA standards for complete care, handling, installation, and maintenance instructions. For additional product and system information Viking data pages and installation instructions are available on the Viking Web site at [www.vikinggroupinc.com](http://www.vikinggroupinc.com).**



**BULLETIN****REGULATORY AND HEALTH  
WARNINGS**

The Viking Corporation, 210 N Industrial Park Drive, Hastings MI 49058

Telephone: 269-945-9501 Technical Services: 877-384-5464 Fax: 269-818-1680 Email: [techsvcs@vikingcorp.com](mailto:techsvcs@vikingcorp.com)

Visit the Viking website for the latest edition of this technical data page [www.vikinggroupinc.com](http://www.vikinggroupinc.com)

**1. DESCRIPTION**

Regulatory and Health Warnings applying to materials used in the manufacture and construction of fire protection products are provided herein as they relate to legally mandated jurisdictional regions.

**⚠ WARNING****STATE OF CALIFORNIA, USA**

Installing or servicing fire protection products such as sprinklers, valves, piping etc. can expose you to chemicals including, but not limited to, lead, nickel, butadiene, titanium dioxide, chromium, carbon black, and acrylonitrile which are known to the State of California to cause cancer or birth defects or other reproductive harm.

For more information, go to [www.P65Warnings.ca.gov](http://www.P65Warnings.ca.gov)

**2. WARRANTY TERMS AND CONDITIONS**

For details of warranty, refer to Viking's current list price schedule at [www.vikinggroupinc.com](http://www.vikinggroupinc.com) or contact Viking directly.



## TECHNICAL DATA

## QUICK RESPONSE DRY HORIZONTAL SIDEWALL SPRINKLERS

The Viking Corporation, 210 N Industrial Park Drive, Hastings MI 49058

Telephone: 269-945-9501 Technical Services: 877-384-5464 Fax: 269-818-1680 Email: techsvcs@vikingcorp.com

Visit the Viking website for the latest edition of this technical data page: [www.vikinggroupinc.com](http://www.vikinggroupinc.com)

### 1. DESCRIPTION

Viking Quick Response Dry Horizontal Sidewall Sprinklers are thermosensitive spray sprinklers suitable for use in areas subject to freezing. The sprinklers are designed for dry systems and preaction systems where it is necessary to prevent water or condensation from entering the drop nipple before sprinkler operation. They may also be installed in spaces subject to freezing and supplied from a wet system in an adjacent heated area.

Viking Quick Response Dry HSW Sprinklers are available in various finishes and temperature ratings to meet design requirements. The special Polyester and Electroless Nickel PTFE (ENT) coatings have been investigated for installation in corrosive atmospheres and are listed/approved as corrosion resistant as indicated in the Approval Charts. (Note: FM Global has no approval classification for Polyester coatings as corrosion resistant.)

### 2. LISTINGS AND APPROVALS



**cULus Listed:** Category VNIV

**FM Approved:** Classes 2013 and 2015

**NYC Approved:** MEA 89-92-E, Volume 15

Refer to Approval Charts and Design Criteria for Listing and Approval that must be followed.

### 3. TECHNICAL DATA

#### Specifications:

Available since 1993.

Minimum Operating Pressure: 7 psi (0.5 bar)

Maximum Working Pressure: 175 psi (12 bar).

Factory tested hydrostatically to 500 psi (34.5 bar)

Thread size: 1" NPT or 25 mm BSPT

Nominal K-Factor: 5.6 U.S. (80.6 metric\*) for all listed and approved lengths.

\* Metric K-factor measurement shown is when pressure is measured in Bar. When pressure is measured in kPa, divide the metric K-factor shown by 10.0.

Glass-bulb fluid temperature rated to -65 °F (-55 °C)

Covered by the following U.S. Patent numbers: 8,636,075 and 8,376,060 and 10,220,231

#### Material Standards:

Frame Casting: Brass UNS-C84400

Deflector: Phosphor Bronze UNS-C51000

Bulb: Glass, nominal 3 mm diameter

Belleville Spring Sealing Assembly: Nickel Alloy, coated on both sides with PTFE Tape

Compression Screw: Brass UNS-C36000

Pip Cap: Brass UNS-C31400 or UNS-C31600

Pip Cap Adapter: Brass UNS-C36000

Orifice: Copper UNS-C22000 or UNS-C11000

Tube: ERW Hydraulic Steel Tube

Support (Internal): Stainless Steel UNS-S30400

Barrel: Steel Pipe UNS-G10260, Electrodeposited Epoxy Base finish

Barrel End and Threads: QM Brass

Sleeve (for Adjustable Standard style only): Brass UNS-C26000 or UNS-C26800

#### Escutcheon Materials:

Adjustable Standard Dry Escutcheons: Brass UNS-C26000 or UNS-C26800

Recessed Dry Escutcheons: Cold Rolled Steel UNS-G10080

ENT Coated Adjustable and Recessed Escutcheons: Stainless Steel UNS-S30400

#### Ordering Information: (Also refer to the current Viking price list.)

Order QR Dry HSW Sprinklers by first adding the appropriate suffix for the sprinkler finish, the appropriate suffix for the temperature rating, and then the suffix for the length ("A" dimension) to sprinkler base part number. Order in a specific length noted as the "A" dimension. The "A" dimension is the distance from the face of the fitting (tee) to the desired finished surface of the wall in which it is to be installed.

These sprinklers are listed and approved in lengths from 1-1/2" to 45-1/2" (38.1 mm to 1,156 mm) for the adjustable standard style, 3" to 47" (76.2 mm to 1,194 mm) for the plain barrel style, and 3-1/4" to 47-1/2" (82.5 mm to 1,207 mm) for the adjustable recessed style. Lengths exceeding the standard lengths are available, with no approvals, on a "made-to-order" basis: Recessed Dry HSW up to 65-1/2" (1,664 mm). Adjustable Standard Dry HSW up to 63-1/2" (1,613 mm). Plain Barrel Dry HSW up to 65" (1,651 mm). Contact the manufacturer for more information.

Finish Suffix: Brass = A, Chrome = F, White Polyester = M-W, and ENT = JN

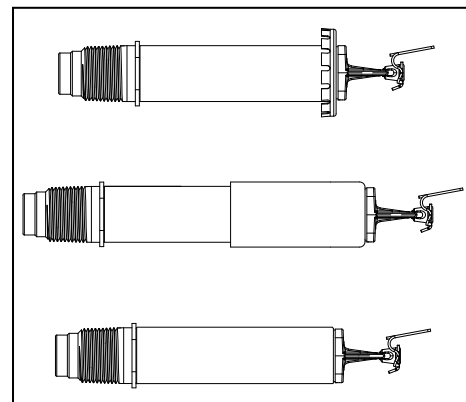

For Light Hazard Occupancies Only

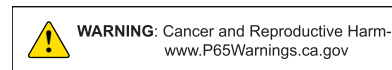



## TECHNICAL DATA

## QUICK RESPONSE DRY HORIZONTAL SIDEWALL SPRINKLERS

The Viking Corporation, 210 N Industrial Park Drive, Hastings MI 49058

Telephone: 269-945-9501 Technical Services: 877-384-5464 Fax: 269-818-1680 Email: techsvcs@vikingcorp.com

Visit the Viking website for the latest edition of this technical data page: [www.vikinggroupinc.com](http://www.vikinggroupinc.com)

Temperature Suffix: 155 °F (68 °C) = B, 175 °F (79 °C) = D, 200 °F (93 °C) = E, 286 °F (141 °C) = G  
Escutcheon Suffix = Y for the adj. recessed sprinkler with the Model G-1 Escutcheon (no suffix needed for the Model E-1 Escutcheon).  
For example, sprinkler VK182 with 1" NPT Threads, a Chrome finish, a 155 °F (68 °C) temperature rating, the Model G-1 Escutcheon, and "A" length of 10" = Part No. 08386UFBY10.

**Available Finishes And Temperature Ratings:** Refer to Table 1.

**Accessories:** (Also refer to the "Sprinkler Accessories" section.)

### Sprinkler Wrenches:

A. Standard Wrench: Part No. 07297W/B (available since 1991)

B. Wrench for recessed sprinklers: Part No. 07565W/B\*\* (available since 1991)

\*\*A ½" ratchet is required (not available from Viking).

### Replacement Escutcheons:

A. Adjustable Standard Dry Escutcheon: Base Part No. 08086F

B. Model E-1 Recessed Dry Escutcheon Cup: Base Part No. 05459A

C. Model G-1 Recessed Dry Escutcheon Cup: Base Part No. 20133

## 4. INSTALLATION

Refer to appropriate NFPA Installation Standards.

## 5. OPERATION

During fire conditions, the heat-sensitive liquid in the glass bulb expands, causing the glass to shatter, releasing the internal parts to open the water-way. Water flowing through the sprinkler orifice strikes the sprinkler deflector, forming a uniform spray pattern to extinguish or control the fire.

## 6. INSPECTIONS, TESTS AND MAINTENANCE

Refer to NFPA 25 for Inspection, Testing and Maintenance requirements.

## 7. AVAILABILITY

The Viking Quick Response Dry Horizontal Sidewall Sprinkler is available through a network of domestic and international distributors. See The Viking Corporation web site for the closest distributor or contact The Viking Corporation.

## 8. GUARANTEE

For details of warranty, refer to Viking's current list price schedule or contact Viking directly.

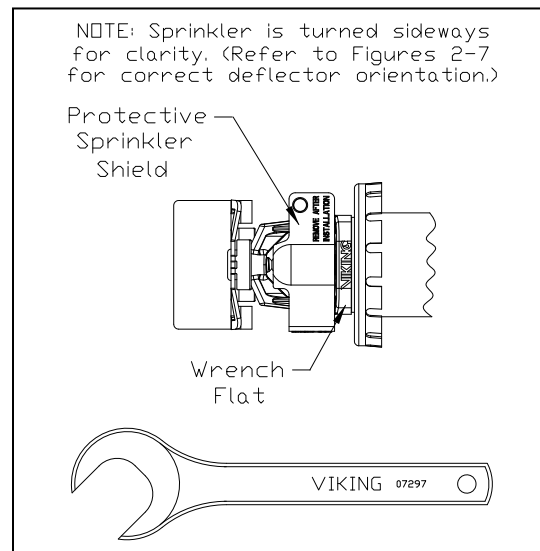

**Figure 1:**  
Standard Sprinkler Wrench 07297W/B

**TABLE 1: AVAILABLE SPRINKLER TEMPERATURE RATINGS AND FINISHES**

Sprinkler Temperature Classification	Sprinkler Nominal Temperature Rating <sup>1</sup>	Maximum Ambient Ceiling Temperature <sup>2</sup>	Bulb Color
Ordinary	155 °F (68 °C)	100 °F (38 °C)	Red
Intermediate	175 °F (79 °C)	150 °F (65 °C)	Yellow
Intermediate	200 °F (93 °C)	150 °F (65 °C)	Green
High	286 °F (141 °C)	225 °F (107 °C)	Blue

**Sprinkler Finishes:** Brass, Chrome, White Polyester, and ENT

**Corrosion-Resistant Coating<sup>3,4</sup>:** White Polyester and ENT in all temperature ratings

### Footnotes

<sup>1</sup> The sprinkler temperature rating is stamped on the deflector.

<sup>2</sup> Based on NFPA-13. Other limits may apply, depending on fire loading, sprinkler location, and other requirements of the Authority Having Jurisdiction. Refer to specific installation standards.

<sup>3</sup> The corrosion-resistant Polyester and ENT coatings have passed the standard corrosion test required by the approving agencies indicated in the Approval Charts. These tests cannot and do not represent all possible corrosive environments. Note: These coatings are NOT corrosion proof. Prior to installation, verify through the end-user that the coatings are compatible with or suitable for the proposed environment. Polyester and ENT coatings are applied to the exposed exterior surfaces only. Note that the spring is exposed on sprinklers with Polyester and ENT coatings.

<sup>4</sup> When installed in some corrosive environments, the Polyester finish may change color. This natural discoloration over time is not in itself an indication of corrosion and should not be treated as such. All sprinklers installed in corrosive environments should be replaced or tested as described in NFPA 25 on a more frequent basis.



**TECHNICAL DATA**

**QUICK RESPONSE  
DRY HORIZONTAL  
SIDEWALL SPRINKLERS**

The Viking Corporation, 210 N Industrial Park Drive, Hastings MI 49058  
 Telephone: 269-945-9501 Technical Services: 877-384-5464 Fax: 269-818-1680 Email: techsvcs@vikingcorp.com  
 Visit the Viking website for the latest edition of this technical data page: www.vikinggroupinc.com

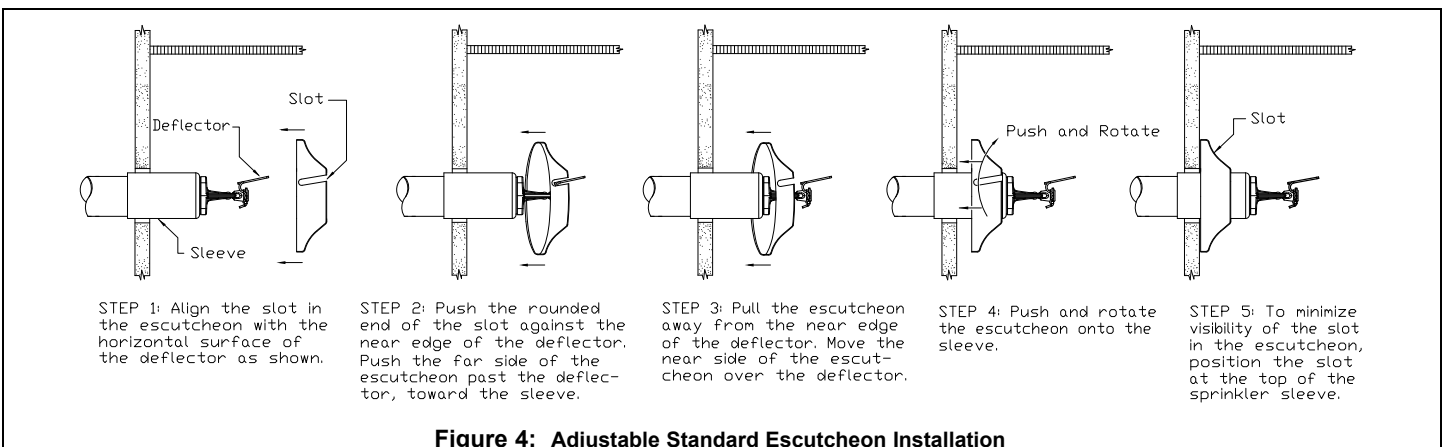
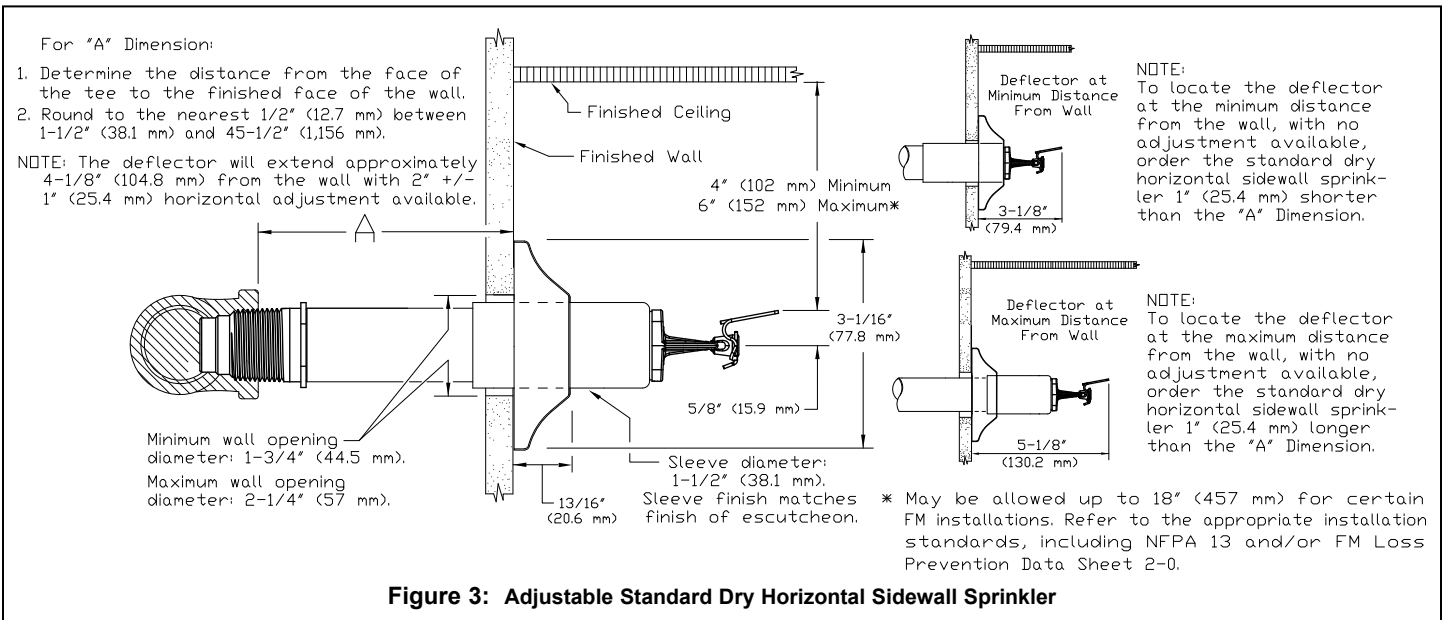
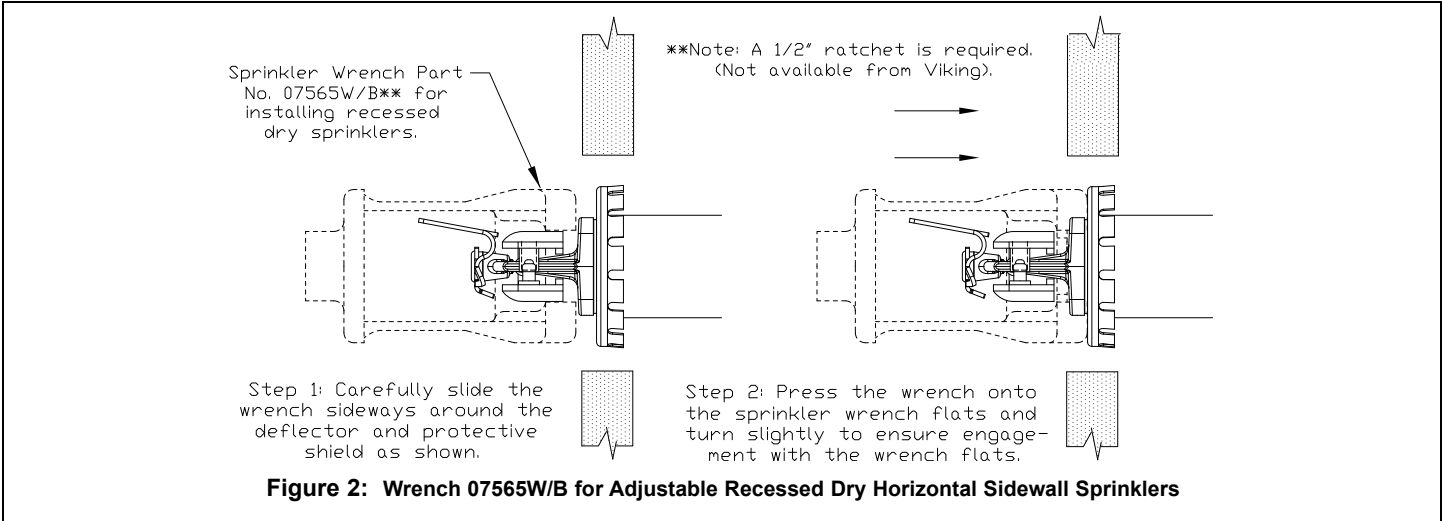



## TECHNICAL DATA

## QUICK RESPONSE DRY HORIZONTAL SIDEWALL SPRINKLERS

The Viking Corporation, 210 N Industrial Park Drive, Hastings MI 49058

Telephone: 269-945-9501 Technical Services: 877-384-5464 Fax: 269-818-1680 Email: techsvcs@vikingcorp.com

Visit the Viking website for the latest edition of this technical data page: www.vikinggroupinc.com

### Approval Chart 1 (UL)

Quick Response Dry Horizontal Sidewall Sprinklers  
For Light Hazard Occupancies Only

Maximum 175 PSI (12 bar) WWP

KEY	
Temperature	↓
Finish	↙
Escutcheon (if applicable)	←

Sprinkler Base Part No. <sup>1</sup>	SIN	Style	Thread Size		Nominal K-Factor <sup>2</sup>		Order Length Increment		Listings and Approvals <sup>4</sup> (Refer also to Design Criteria on page 106e.)						
			NPT	BSPT	U.S.	metric <sup>3</sup>	Inches	mm	cULus <sup>5</sup>	NYC <sup>6</sup>	VdS	LPCB	CE	⚙️	
08384U	VK178	Adjustable	1"	--	5.6	80.6	1/2"	12.7	A1, A5	A1	--	--	--	--	
16458U		Standard	--	25 mm	--	80.6	1/2"	12.7	A1, A5	--	--	--	--	--	
08386U	VK182	Adjustable	1"	--	5.6	80.6	1/4"	6.35	B2, B6	B2	--	--	--	--	
16454U		Recessed	--	25 mm	--	80.6	1/4"	6.35	B2, B6	--	--	--	--	--	
08388U	VK174	Plain Barrel	1"	--	5.6	80.6	1/2"	12.7	A3	A4	--	--	--	--	
16456U			--	25 mm	--	80.6	1/2"	12.7	A3	--	--	--	--	--	

#### Approved Temperature Ratings

A - 155 °F (68 °C), 175 °F (79 °C), 200 °F (93 °C), and 286 °F (141 °C)  
B - 155 °F (68 °C), 175 °F (79 °C), and 200 °F (93 °C)

#### Approved Finishes and "A" Dimensions

- 1\* - Chrome, or White Polyester<sup>7</sup> sprinkler with a Chrome, Brass, or White Polyester Sleeve and Escutcheon with "A" dimensions 1-1/2" to 45-1/2" (38.1 mm to 1,156 mm)
- 2\* - Chrome, or White Polyester<sup>7</sup> with "A" dimensions 3-1/4" to 47-1/2" (82.5 mm to 1,207 mm)
- 3 - Chrome, Brass, White Polyester<sup>7</sup>, or ENT<sup>7</sup> with "A" dimensions 3" to 47" (76.2 mm to 1,194 mm)
- 4 - Chrome or Brass with "A" dimensions 3" to 47" (76.2 mm to 1,194 mm)
- 5 - ENT<sup>7</sup> sprinkler with an ENT<sup>7</sup> Sleeve and Escutcheon with "A" dimensions 1-1/2" to 45-1/2" (38.1 mm to 1,156 mm)
- 6 - ENT<sup>7</sup> with "A" dimensions 3-1/4" to 47-1/2" (82.5 mm to 1,207 mm)

\*Brass Finish is listed and approved but not standard offering, lead times of 6-8 weeks required.  
(Matching Brass escutcheons are not available.)

#### Footnotes

- <sup>1</sup> Part number shown is the base part number. For complete part number, refer to current Viking price list schedule.
- <sup>2</sup> K-Factor applies for standard lengths ("A" Dimensions indicated above).
- <sup>3</sup> Metric K-factor shown is for use when pressure is measured in bar. When pressure is measured in kPa, divide the metric K-factor shown by 10.0.
- <sup>4</sup> This chart shows the listings and approvals available at the time of printing. Other approvals may be in process. Check with the manufacturer for any additional approvals.
- <sup>5</sup> Listed by Underwriter's Laboratories for use in the U.S. and Canada for Light Hazard occupancies only.
- <sup>6</sup> Accepted for use, City of New York Department of Buildings, MEA Number 89-92-E, Vol. 15.
- <sup>7</sup> cULus Listed as corrosion resistant.

### DESIGN CRITERIA - UL

(Also refer to Approval Chart 1 above.)

#### cULus Listing Requirements:

Quick Response Dry Horizontal Sidewall Sprinklers are cULus Listed as indicated in Approval Chart 1 for installation in accordance with the latest edition of NFPA 13 for standard spray sprinklers.

- Limited to Light Hazard occupancies only.
- Protection areas and maximum spacing shall be in accordance with the tables provided in NFPA 13.
- Minimum spacing allowed is 6 ft. (1.8 m).
- Deflector must be positioned between 4" and 6" (102 mm and 152 mm) below the ceiling. Keep the top of the deflector oriented parallel with the ceiling.
- Locate no less than 4" (102 mm) from end walls.
- Maximum distance from end walls shall be no more than one-half of the allowable distance between sprinklers. The distance shall be measured perpendicular to the wall.
- The sprinkler installation and obstruction rules contained in NFPA 13 for sidewall standard spray sprinklers must be followed.

**IMPORTANT: Always refer to Bulletin Form No. F\_091699 - Care and Handling of Sprinklers. Also refer to Form No. F\_080614 for general care, installation, and maintenance information. Viking sprinklers are to be installed in accordance with the latest edition of Viking technical data, the appropriate standards of NFPA, LPCB, APSAD, VdS or other similar organizations, and also with the provisions of governmental codes, ordinances, and standards, whenever applicable.**



## TECHNICAL DATA

## QUICK RESPONSE DRY HORIZONTAL SIDEWALL SPRINKLERS

The Viking Corporation, 210 N Industrial Park Drive, Hastings MI 49058  
 Telephone: 269-945-9501 Technical Services: 877-384-5464 Fax: 269-818-1680 Email: techsvcs@vikingcorp.com  
 Visit the Viking website for the latest edition of this technical data page: www.vikinggroupinc.com

### Approval Chart 2 (FM)

Quick Response Dry Horizontal Sidewall Sprinklers  
 For Light Hazard Occupancies Only

Maximum 175 PSI (12 bar) WWP

KEY	
Temperature	→
Finish	↓
Escutcheon (if applicable)	A1X ←

Sprinkler Base Part No. <sup>1</sup>	SIN	Style	Thread Size		Nominal K-Factor <sup>2</sup>		Order Length Increment		FM Approvals <sup>4</sup> (Refer also to Design Criteria below.)
			NPT	BSP	U.S.	metric <sup>3</sup>	Inches	mm	
08384U	VK178	Adjustable Standard	1"	--	5.6	80.6	1/2"	12.7	A1
16458U			--	25 mm	--	80.6	1/2"	12.7	A1
08386U	VK182	Adjustable Recessed	1"	--	5.6	80.6	1/4"	6.35	B2
16454U			--	25 mm	--	80.6	1/4"	6.35	B2
08388U	VK174	Plain Barrel	1"	--	5.6	80.6	1/2"	12.7	A3
16456U			--	25 mm	--	80.6	1/2"	12.7	A3

#### Approved Temperature Ratings

A - 155 °F (68 °C), 175 °F (79 °C), 200 °F (93 °C), and 286 °F (141 °C)  
 B - 155 °F (68 °C), 175 °F (79 °C), and 200 °F (93 °C)

#### Approved Finishes and "A" Dimensions

- 1\* - Bright Brass, Chrome, White Polyester, or ENT<sup>5</sup> with "A" dimensions 1-1/2" to 45-1/2" (38.1 mm to 1,156 mm)  
 2\* - Bright Brass, Chrome, White Polyester, or ENT<sup>5</sup> with "A" dimensions 3-1/4" to 47-1/2" (82.5 mm to 1,207 mm)  
 3 - Brass, Bright Brass, Chrome, White Polyester, or ENT<sup>5</sup> "A" dimensions 3" to 47" (76.2 mm to 1,194 mm)

\*Brass Finish is listed and approved but not standard offering, lead times of 6-8 weeks required.  
 (Matching Brass escutcheons are not available.)

#### Footnotes

- <sup>1</sup> Part number shown is the base part number. For complete part number, refer to current Viking price list schedule.  
<sup>2</sup> K-Factor applies for standard lengths ("A" Dimensions indicated above).  
<sup>3</sup> Metric K-factor shown is for use when pressure is measured in bar. When pressure is measured in kPa, divide the metric K-factor shown by 10.0.  
<sup>4</sup> This chart shows the FM Approvals available at the time of printing. Other approvals may be in process. Check with the manufacturer for any additional approvals.  
<sup>5</sup> FM approved as corrosion resistant.

### DESIGN CRITERIA - FM

(Also refer to Approval Chart 2 above.)

#### FM Approval Requirements:

The Dry HSW Sprinklers in the Approval Chart above are FM Approved as quick response **Non-storage** standard spray sprinklers as indicated in the FM Approval Guide. For specific application and installation requirements, reference the latest applicable FM Loss Prevention Data Sheets (including 2-0) and Technical Advisory Bulletins. FM Global Loss Prevention Data Sheets and Technical Advisory Bulletins contain guidelines relating to, but not limited to: minimum water supply requirements, hydraulic design, ceiling slope and obstructions, minimum and maximum allowable spacing, and deflector distance below the ceiling.

**NOTE:** The FM installation guidelines may differ from cULus and/or NFPA criteria.

**IMPORTANT:** Always refer to Bulletin Form No. F\_091699 - Care and Handling of Sprinklers. Also refer to Form No. F\_080614 for general care, installation, and maintenance information. Viking sprinklers are to be installed in accordance with the latest edition of Viking technical data, the appropriate standards of NFPA, FM Global, LPCB, APSAD, VdS or other similar organizations, and also with the provisions of governmental codes, ordinances, and standards, whenever applicable.



TECHNICAL DATA

QUICK RESPONSE  
DRY HORIZONTAL  
SIDEWALL SPRINKLERS

The Viking Corporation, 210 N Industrial Park Drive, Hastings MI 49058

Telephone: 269-945-9501 Technical Services: 877-384-5464 Fax: 269-818-1680 Email: techsvcs@vikingcorp.com

Visit the Viking website for the latest edition of this technical data page: www.vikinggroupinc.com

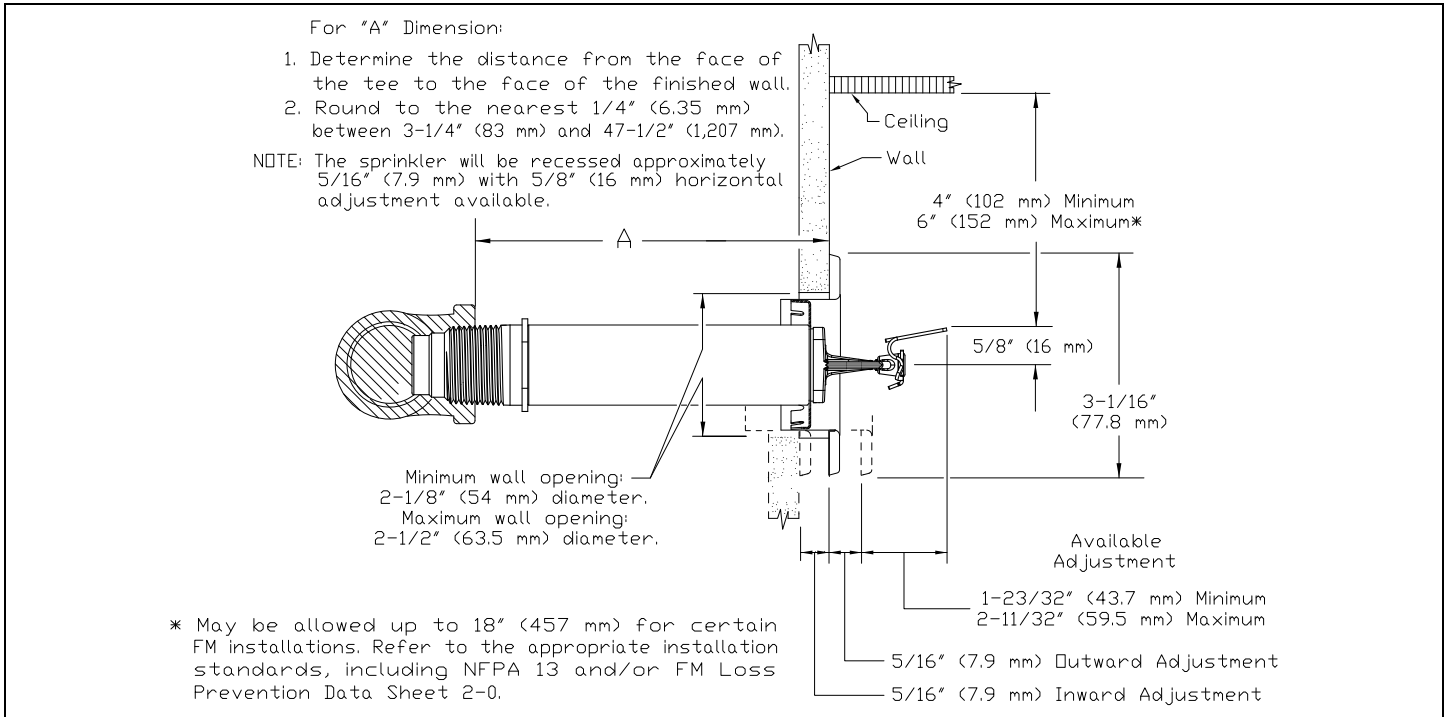

Figure 5: Adjustable Recessed Dry Horizontal Sidewall Sprinkler with the Model E-1 Escutcheon

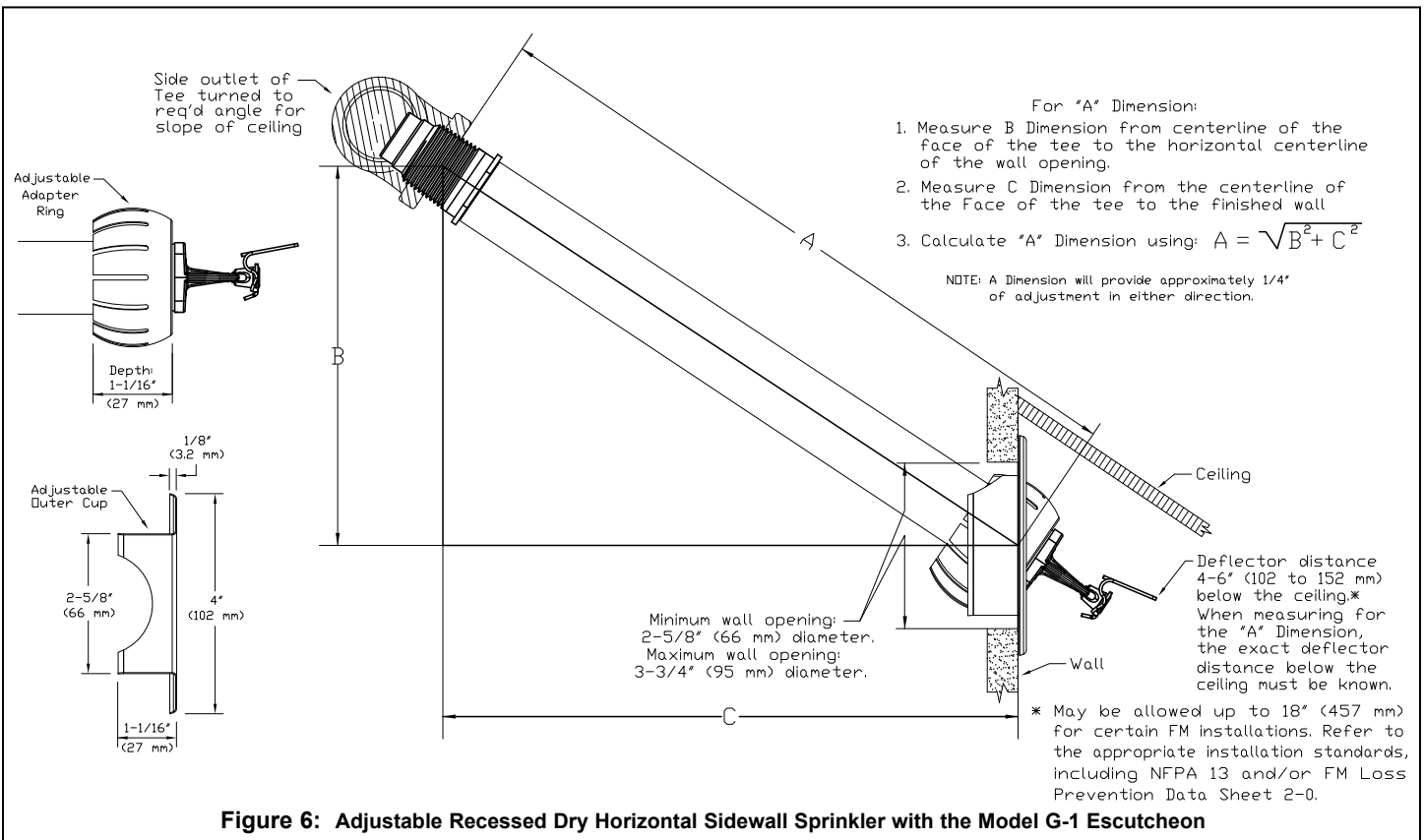

Figure 6: Adjustable Recessed Dry Horizontal Sidewall Sprinkler with the Model G-1 Escutcheon



**TECHNICAL DATA**

**QUICK RESPONSE  
DRY HORIZONTAL  
SIDEWALL SPRINKLERS**

The Viking Corporation, 210 N Industrial Park Drive, Hastings MI 49058

Telephone: 269-945-9501 Technical Services: 877-384-5464 Fax: 269-818-1680 Email: techsvcs@vikingcorp.com

Visit the Viking website for the latest edition of this technical data page: www.vikinggroupinc.com

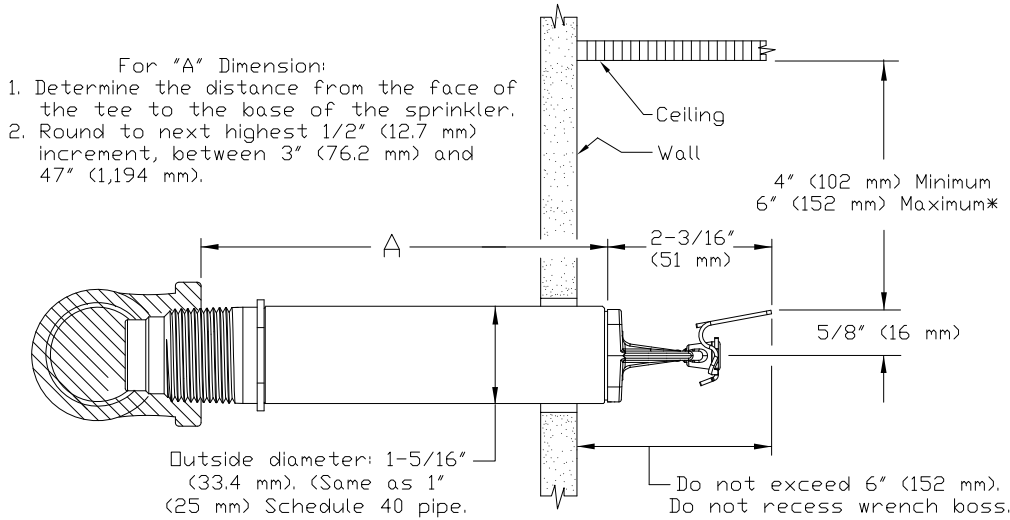

\* May be allowed up to 18" (457 mm) for certain FM installations. Refer to the appropriate installation standards, including NFPA 13 and/or FM Loss Prevention Data Sheet 2-0.

**Figure 7: Quick Response Plain Barrel Dry Horizontal Sidewall Sprinkler**





**TECHNICAL DATA**

**QUICK RESPONSE  
DRY HORIZONTAL  
SIDEWALL SPRINKLERS**

The Viking Corporation, 210 N Industrial Park Drive, Hastings MI 49058

Telephone: 269-945-9501 Technical Services: 877-384-5464 Fax: 269-818-1680 Email: techsvcs@vikingcorp.com

Visit the Viking website for the latest edition of this technical data page: www.vikinggroupinc.com

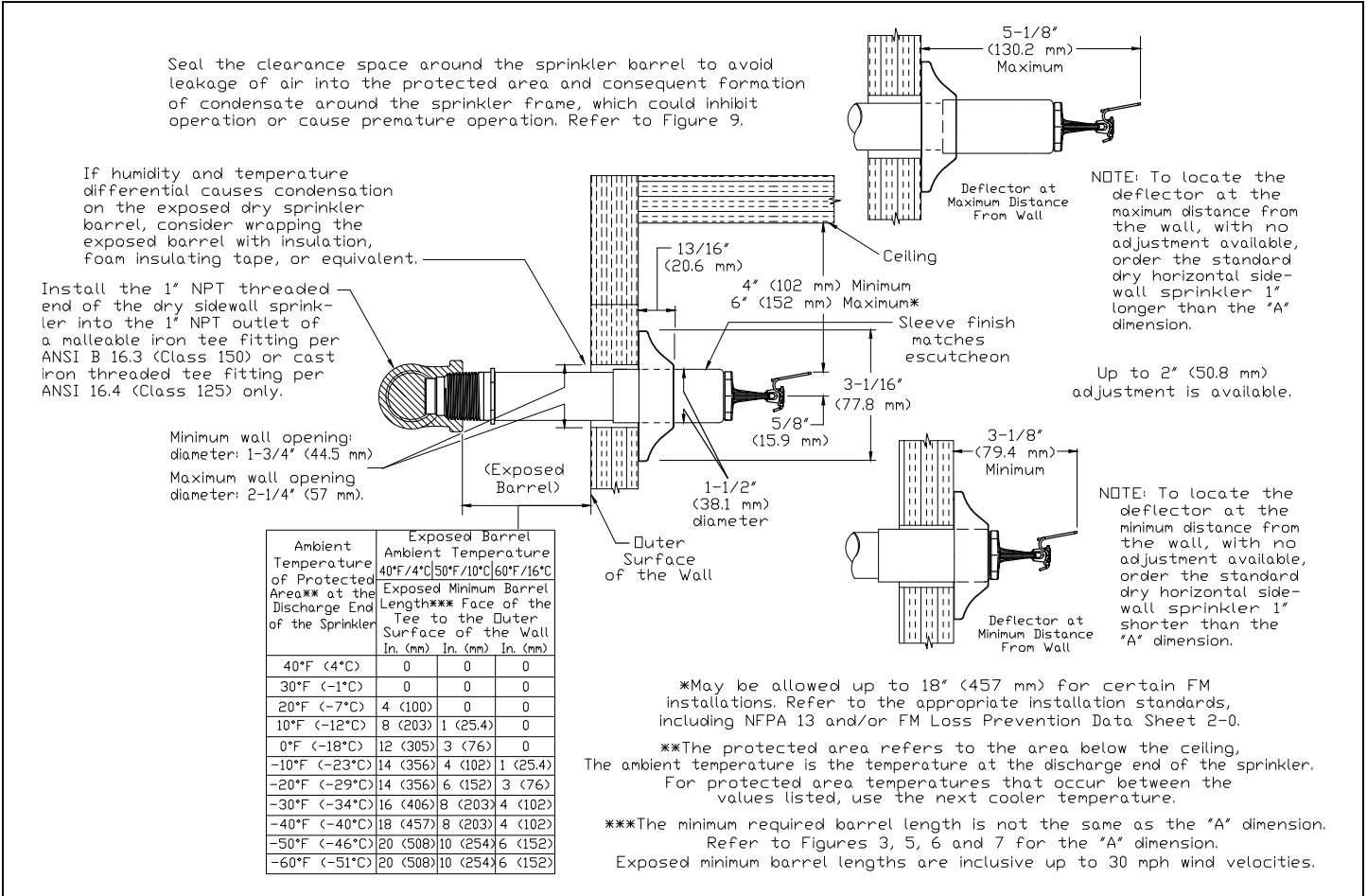

**Figure 8: Dry Horizontal Sidwall Sprinkler Required Minimum Barrel Length Based on Ambient Temperature in the Protected Area (Adjustable Standard Dry HSW Sprinkler is Shown)**

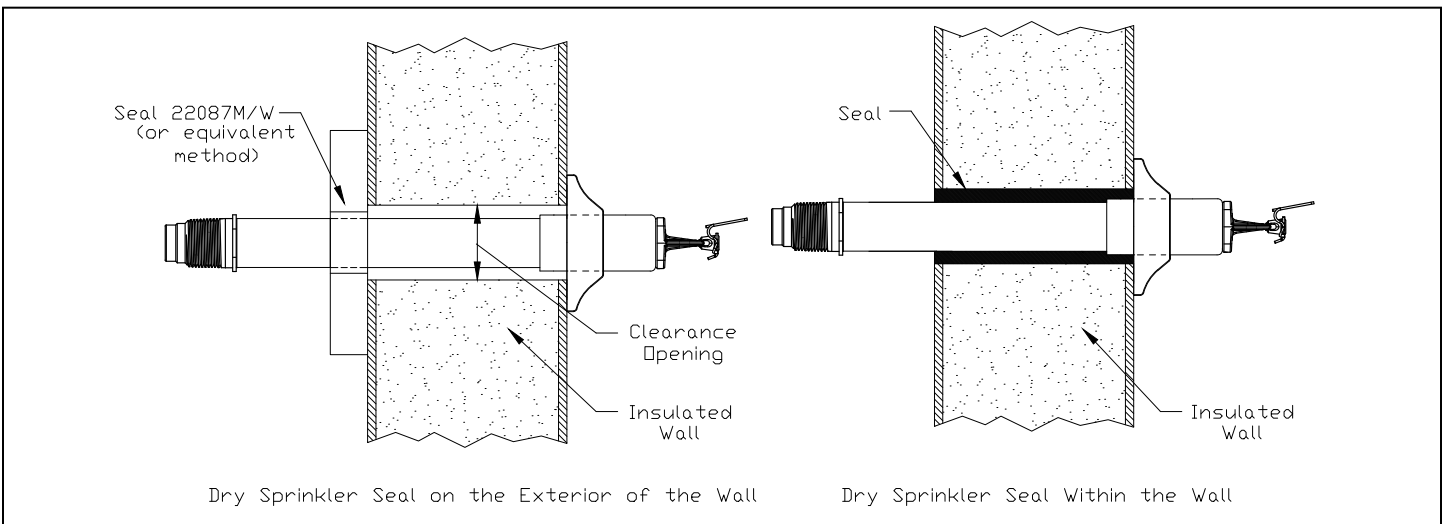

**Figure 9: Dry Sprinkler Seal (Adjustable Standard Dry HSW Sprinkler is Shown)**



## Submittal Data for CPVC Strap Hangers

All materials to be used in the installation of sprinkler system are to conform to NFPA 13, 13R and 13D, Local Authorities having Jurisdiction and any applicable referenced codes and standards.

UL Listed in the USA and Canada to support fire sprinkler piping.

- A “one-hole strap” can function as a hanger and restraining device. It supports CPVC pipe horizontally from top or side of beam. As a restraining device, the hanger will be inverted so the fastener is downward. This installation will prevent upward movement of the sprinkler during activation.
- A “two-hole strap” can function as a hanger and restraining device. It supports CPVC pipe horizontally from top, bottom, or side of beam. A hex-head self-threading screw (furnished with most CPVC hangers) is easily installed using an electric drill. No pre-drilling pilot hole is required.
- A “side-mount strap” supports the CPVC pipe horizontally from top or bottom of beam
- A “stand-off 2-hole strap” supports the CPVC pipe off of the vertical face of the structural or composite wood joists.

Hangers must be clean, free of burrs, and all surface oils. Any contaminants must be removed from the hanger.

The pipe size of the hanger shall be the same size as the supported pipe.

Pipe hangers must have a load bearing surface at least ½” inch wide.

Examples of CPVC Hangers

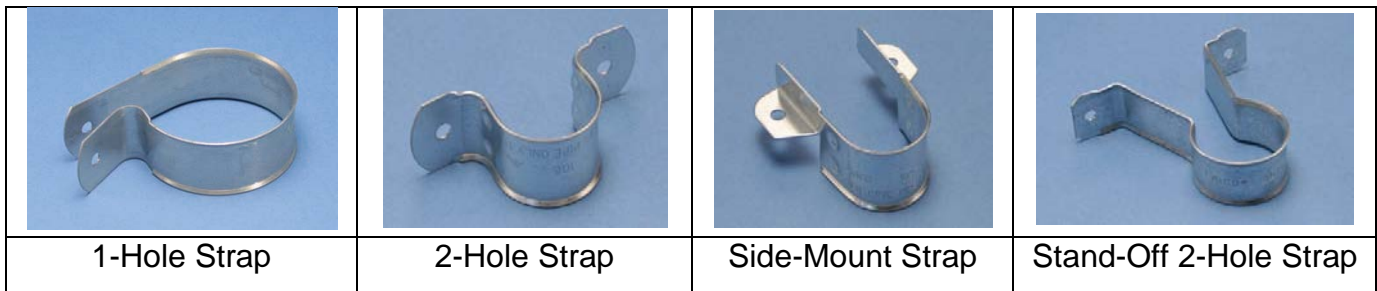

### This submittal shall include the following checked items:

**Product**

<input checked="" type="checkbox"/>	¾” Hangers
<input checked="" type="checkbox"/>	1” Hangers
<input type="checkbox"/>	1-1/4” Hangers
<input type="checkbox"/>	1-1/2” Hangers
<input checked="" type="checkbox"/>	2” Hangers

**Origin of Manufacture**

Domestic	Foreign
<input type="checkbox"/>	<input checked="" type="checkbox"/>

## Engineering Specification

Job Name \_\_\_\_\_  
 Job Location \_\_\_\_\_  
 Engineer \_\_\_\_\_  
 Approval \_\_\_\_\_

Contractor \_\_\_\_\_  
 Approval \_\_\_\_\_  
 Contractor's P.O. No. \_\_\_\_\_  
 Representative \_\_\_\_\_

## Series 009, 009-FS Reduced Pressure Zone Assemblies

1/4" – 2"

Series 009 and 009-FS Reduced Pressure Zone assemblies are designed to protect potable water supplies in accordance with national plumbing codes and water authority requirements. This series is designed to protect drinking water supplies from dangerous cross-connections in accordance with national plumbing codes and water authority requirements for non-potable service applications such as irrigation, fireline, or industrial processing.

The series features two in-line, independent check valves, captured springs, and replaceable check seats with an intermediate relief valve. Its compact modular design facilitates easy maintenance and assembly access. Sizes 1/4" to 1" shutoffs have tee handles.

Series 009-FS assemblies of sizes 1/2" to 2" include an integrated flood sensor to detect excessive water discharges from the relief valve. When activated through an add-on sensor connection kit, the flood sensor relays a signal that triggers notification to qualified service personnel who can take corrective action, thus avoiding the possibility of ruinous flooding and costly damage. The add-on sensor connection kit is available for both building management systems, or BMS, and cellular communication. (For more information, refer to *Installation, Maintenance, and Repair Manual, Series 009-FS and LF009-FS.*)

### Features

- Single access cover and modular check construction for ease of maintenance
- Top entry to all internals for immediate accessibility
- Captured springs for safe maintenance
- Internal relief valve for reduced installation clearances
- Replaceable seats for economical repair
- Bronze body construction for durability (1/4" – 2")
- Ball valve test cocks — screwdriver slotted (1/4" – 2")
- Large body passages provides low pressure drop
- Compact, space saving design
- No special tools required for servicing
- Integrated sensor for flood detection (1/2" – 2")

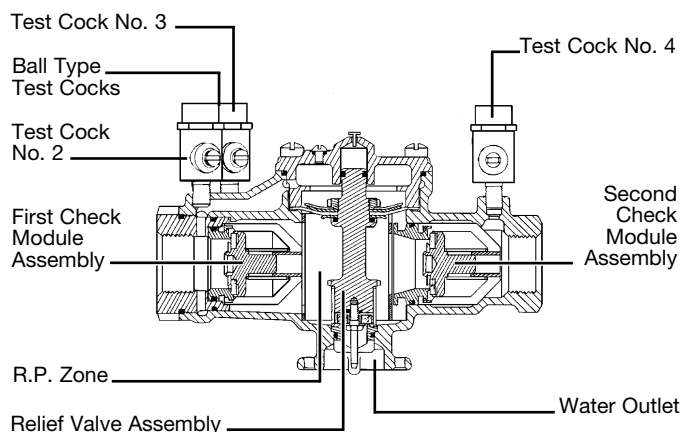

### WARNING

It is illegal to use this product in any plumbing system providing water for human consumption, such as drinking or dishwashing, in the United States. Before installing standard material product, consult your local water authority, building and plumbing codes.

### NOTICE

The information contained herein is not intended to replace the full product installation and safety information available or the experience of a trained product installer. You are required to thoroughly read all installation instructions and product safety information before beginning the installation of this product.

Inquire with governing authorities for local installation requirements.

## Specification

A Reduced Pressure Zone Assembly shall be installed at each potential health hazard location to prevent backflow due to back-siphonage and/or backpressure. The assembly shall consist of an internal pressure differential relief valve located in a zone between two positive seating check modules with captured springs and silicone seat discs. Seats and seat discs shall be replaceable in both check modules and the relief valve. There shall be no threads or screws in the waterway exposed to line fluids. Service of all internal components shall be through a single access bronze cover secured with stainless steel bolts. The assembly shall also include two resilient seated isolation valves, four resilient seated test cocks, and an air gap drain fitting. The assembly shall meet the requirements of USC; ASSE Std. 1013; AWWA Std. C511-92; CSA B64.4. Shall be a Watts® Series 009.

## Model/Option

### Prefix:

U – Union connections (For more information download ES-U009-FS at watts.com.)

### Suffix:

- AQT – Elbow fittings for 360° rotation (¾" – 2")
- FS – Integrated sensor for flood detection (½" – 2")
- HC – 2½" Inlet/outlet fire hydrant fitting (2")
- LF – Without shutoff valves
- PC – Internal polymer coating
- QT – Quarter-turn ball valves
- S – Bronze strainer
- SH – Stainless steel ball valve handles

## Materials

Bronze body construction, silicone rubber disc material in the first and second check plus the relief valve. Replaceable polymer check seats for first and second checks. Removable relief valve seats. Stainless steel cover bolts.

Standardly furnished with NPT body connections. For optional bronze union inlet and outlet connections, specify prefix U (½" – 2"). Series 009QT furnished with quarter turn, full port, resilient seated, bronze ball valve shutoffs.

## Pressure / Temperature

Suitable for supply pressure up to 175 psi (12.1 bar)  
Water temperature: 33°F – 180°F (0.5°C – 75°C)

## Standards

USC  
ASSE No. 1013  
AWWA C511-92  
CSA B64.4  
IAPMO File No. 1563

## Approvals



ASSE, AWWA, CSA, IAPMO

Approved by the Foundation for Cross-Connection Control and Hydraulic Research at the University of Southern California

UL Classified ¾" – 2"  
(LF models only except 009M3LF)

## Insulated Enclosure

The WattsBox insulated enclosure is available for Series 009/009-FS. For more information download ES-WB at watts.com.

## Dimensions and Weight

1/4" - 3/8"

1/2" - 2"

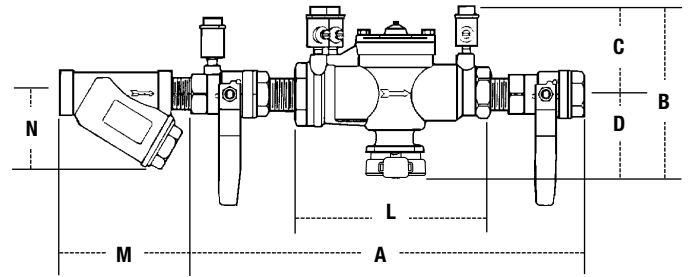
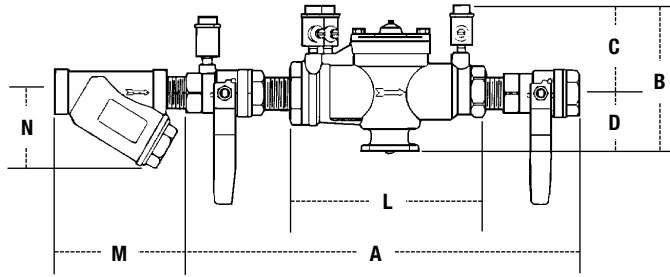

MODEL	DIMENSIONS (APPROX.)								STRAINER DIMENSIONS				WEIGHT			
in.	A		B		C		D		L		M		N		lb	kg
	in.	mm	in.	mm	in.	mm	in.	mm	in.	mm	in.	mm	in.	mm		
1/4	10	250	4 5/8	117	3 3/8	86	1 1/4	32	5 1/2	140	2 3/8	60	2 1/2	64	5	2
3/8	10	250	4 5/8	117	3 3/8	86	1 1/4	32	5 1/2	140	2 3/8	60	2 1/2	64	5	2
1/2	10	250	5 7/8	149	3 3/8	86	2 1/2	64	5 1/2	140	2 3/4	70	2 1/4	57	5	2
3/4	10 3/4	273	6 1/4	159	3 1/2	89	2 3/4	70	6 3/4	171	3 3/16	81	2 3/4	70	6	3
1	14 1/2	368	6 1/4	159	3	76	3 1/4	83	9 1/2	241	3 3/4	95	3	76	12	5
1 1/4	17 3/8	441	6 3/4	169	3 1/2	89	3 1/4	83	11 3/8	289	4 7/16	113	3 1/2	89	15	6
1 1/2	17 7/8	454	6 3/4	169	3 1/2	89	3 1/4	83	11 1/8	283	4 7/8	124	4	102	16	7
2	21 3/8	543	8 3/4	222	4 1/2	114	4 1/4	108	13 1/2	343	5 15/16	151	5	127	30	13

Suffix HC - Fire Hydrant Fittings dimension 'A' = 25"

## Air Gaps and Elbows

MODEL	SIZE	DRAIN OUTLET		DIMENSIONS				WEIGHT	
	For 909, 009, and 993	in.	mm	A		B		lb	kg
				in.	mm	in.	mm		
909AGA	1/4"-1/2" 009, 3/4" 009M2/M3	1/2	13	2 3/8	60	3 3/8	79	0.625	0.28
909AGC	3/4"-1" 009/909, 1"-1 1/2" 009M2	1	25	3 1/4	83	4 7/8	124	1.5	0.68
909AGF	1 1/4"-2" 009M1, 1 1/4"-3" 009/909, 2" 009M2, 4"-6" 993	2	51	4 3/8	111	6 3/4	171	3.25	1.47
909AGK	4"-6" 909, 8"-10" 909M1	3	76	6 3/8	162	9 3/8	244	6.25	2.83
909AGM	8"-10" 909	4	102	7 3/8	187	11 1/4	286	15.5	7.03
909ELA	1/4"-1/2" 009, 3/4" 009M2/M3	-	-	-	-	-	-	-	-
909ELC	3/4"-1" 009/909	-	-	2 3/8	60	2 3/8	60	0.38	0.17
909ELF*	1 1/4"-2" 009M1, 1 1/4"-2" 009/909, 2" 009M2, 4"-6" 993	-	-	3 3/8	92	3 3/8	92	2	0.91
909ELH*	2 1/2"-3" 009/909	-	-	-	-	-	-	-	-
Vertical									

\* Epoxy coated

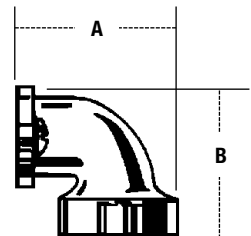
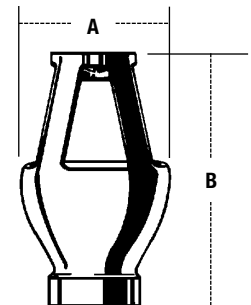

# Capacity

Performance as established by an independent testing laboratory.

The asterisk (\*) indicates typical maximum system flow rate (7.5 ft/sec, 2.3 m/sec).

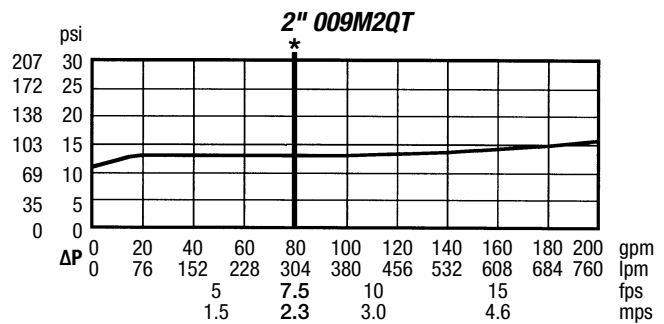
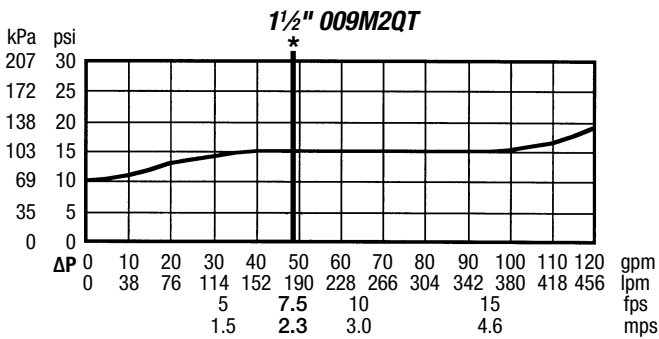
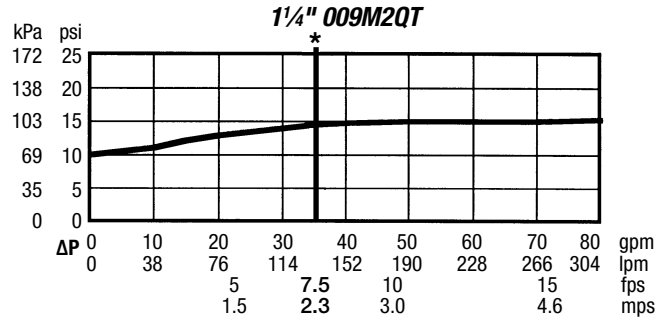
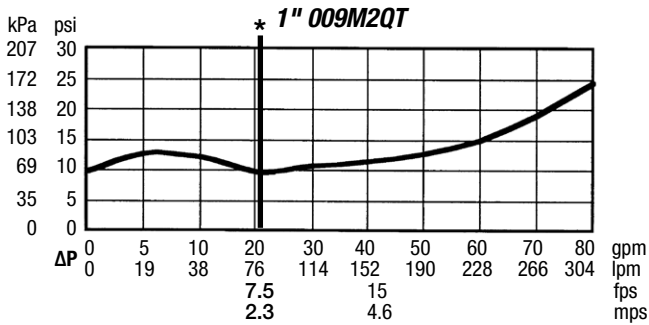
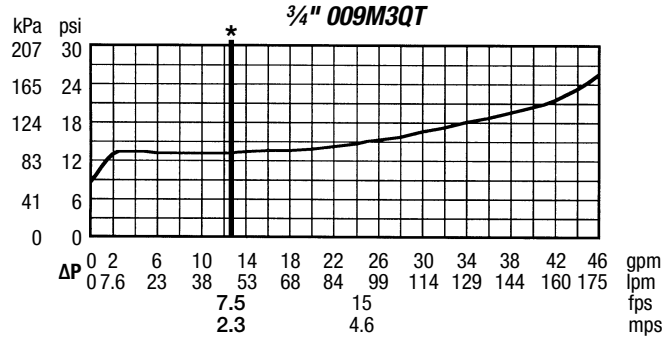
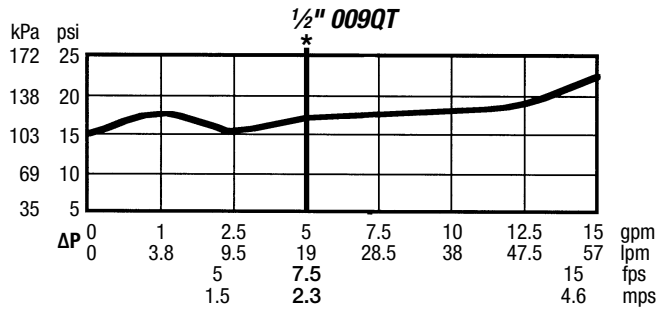
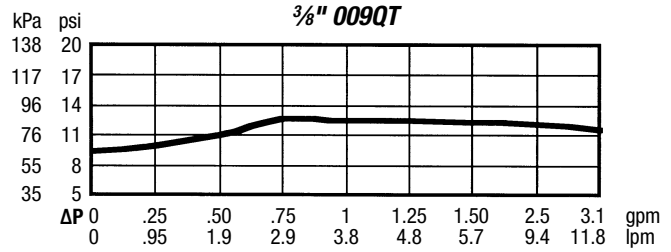
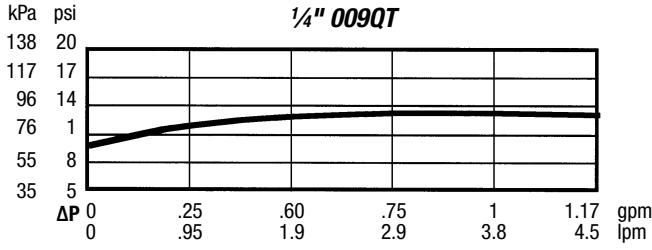

USA: T: (978) 689-6066 • Watts.com  
 Canada: T: (888) 208-8927 • Watts.ca  
 Latin America: T: (52) 55-4122-0138 • Watts.com



## Submittal Data CPVC Pipe and Fittings

### Listings:

- Light hazard occupancies as defined in the standard for “Installation of Sprinkler Systems”, NFPA 13.
- Residential occupancies as defined in the standard for “Installation of Sprinkler Systems in Residential Occupancies up to and Including Four Stories in Height”, NFPA 13R.
- Residential occupancies as defined in the standard for “Installation of Sprinkler Systems in One and Two Family Dwellings and Manufactured Homes”, NFPA 13D. - Underground fire service systems as described in the “Installation of Sprinkler
- Systems”, NFPA 13 2007 Edition, and where appropriate the “Standard for Installation of Private Service Mains & Their Appurtenances”, NFPA 24
- Local Authorities having jurisdiction and any applicable referenced
- codes and standards.

### Approvals:

UL, FM, CUL, NSF, Dade County, LPCB, MEA, and the City of Los Angeles.

### Material Specifications:

Pipe: ASTM F442, SDR 13.5

Fittings: ASTM F438, (Sch. 40) and ASTM F439 (Sch. 80)

Maximum Working Pressure of 175 PSI



Straight Elbow



Reducing Elbow



Straight Tee



Reducing Tee



Cross



Reducing Cross



45 Elbow



Coupling



Sprinkler Adapter  
w/ Brass Insert



Slip-Thread Adapter



Sprinkler Head Adapter 90° Ell



Sprinkler Head Adapter Tee



Back-to-Back Tee



Grooved Coupling Adapter



Reducer Bushing



Cap

### CPVC Pipe Submittal Data for Fire Sprinkler Systems

All material used in the installation of the sprinkler system conforms to:

NFPA 13

NFPA 13R

NFPA 13D



- All CPVC piping should be pressure tested at 200 PSI for 2 hours.
- Chemical compatibility should be checked per manufacturer.
- Glycerin antifreeze solutions are acceptable and installation of antifreeze systems should comply with NFPA Section 7.6.2 of NFPA 13 (2007 Edition).

BlazeMaster® Pipe Dimensions and Weights SDR 13.5 (ASTM F 442)									
Nominal Size		Average OD		Average ID		Pounds Per Foot	Kilograms Per Meter	Pounds Per Foot	Kilograms Per Meter
Inches	mm	Inches	mm	Inches	mm	Empty	Empty	H <sub>2</sub> O Filled	H <sub>2</sub> O Filled
3/4	20.0	1.050	26.7	.874	22.2	0.168	0.250	0.428	0.637
1	25.0	1.315	33.4	1.101	28.0	0.262	0.390	0.675	1.005
1 1/4	32.0	1.660	42.2	1.394	35.4	0.418	0.622	1.079	1.606
1 1/2	40.0	1.900	48.3	1.598	40.6	0.548	0.816	1.417	2.109
2	50.0	2.375	60.3	2.003	50.9	0.859	1.278	2.224	3.310
2 1/2	65.0	2.875	73.0	2.423	61.5	1.257	1.871	3.255	4.844
3	80.0	3.500	88.9	2.950	75.0	1.867	2.778	4.829	7.186

Note: The above average OD and average ID information is per ASTM F442. Check with individual manufacturers for actual OD and ID information.

Allowance for Friction Loss in Fittings (Equivalent Feet of Pipe)								
Fitting Size (In.)	3/4"	1"	1 1/4"	1 1/2"	2"	2 1/2"	3"	
Tee Branch	3	5	6	8	10	12	15	
Elbow 90° *	4	5	6	7	9	12	13	
Elbow 45°	1	1	2	2	2	3	4	
Coupling	1	1	1	1	1	2	2	
Tee Run	1	1	1	1	1	2	2	





# UNITED BRASS WORKS, INC.

714 S. Main St., Randleman, NC 27317

Tel: 800-334-3035 Fax: 800-498-4696 www.ubw.com



## Model 99S Swing Check Valve

**200 WOG @ 180 ° Max**

**100% Pressure Tested • Integral Seat**

**Threaded Ends • Soft Disc**

*Not recommended for pulsating or vibrating service.*

*Do Not Install laying on side.*

*Keep seat clean.*

### MATERIAL LIST

NO.	DESCRIPTION	MATERIAL
1	Cap (1/4" - 1") Cap (1 1/4" - 2")	Brass Bronze
2	Washer	Brass
3	Body	Bronze
4	Disc	Brass
5	Hinge	Stainless Steel
6	Disc	Buna-N

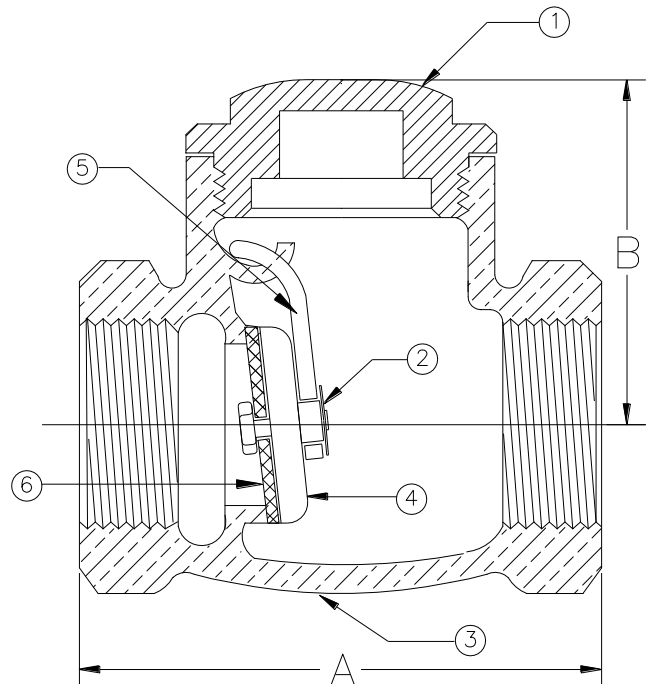

Size	1/4"	3/8"	1/2"	3/4"	1"	1 1/4"	1 1/2"	2"
A	1.89	1.89	2.14	2.51	3.03	3.45	3.81	4.44
B	1.22	1.22	1.28	1.53	2.06	2.20	2.20	2.86
Ship Wgt. (lbs.)	0.45	0.45	0.58	0.81	1.62	1.81	2.41	3.42
Qty. Unit Pack	12	12	12	12	6	6	4	2
Qty. Per Case	60	60	60	60	30	18	12	6



## TECHNICAL DATA

### EASYPAC RESIDENTIAL RISER MANIFOLD ASSEMBLIES 1" - 2" (DN25 - DN50)

The Viking Corporation, 210 N Industrial Park Drive, Hastings MI 49058

Telephone: 269-945-9501 Technical Services 877-384-5464 Fax: 269-818-1680 Email: techsvcs@vikingcorp.com

Visit the Viking website for the latest edition of this technical data page [www.vikinggroupinc.com](http://www.vikinggroupinc.com)

## 1. DESCRIPTION

Viking EasyPac Residential Riser Manifold Assemblies are available in sizes 1", 1-1/4", 1-1/2", and 2" for NFPA 13D and NFPA13R residential fire sprinkler systems. The configuration eliminates the need to drain the system before installing the relief valve, while a built in test port allows hydrostatic testing without draining the system. The EasyPac Residential Assemblies include pressure gauges, Potter flow switches, 3-way gauge control valve and 1" drain valve (or 1-1/4" for 2" Manifold). The EasyPac assemblies are made with steel bodies and are available in threaded or grooved connections.

## 2. LISTINGS AND APPROVALS



**WARNING:** Cancer and Reproductive Harm-  
[www.P65Warnings.ca.gov](http://www.P65Warnings.ca.gov)

**Pressure Gauges:** UL Listed - Category VEVX, FM Approved

**Waterflow Alarm Switch:** UL Listed - Category USQT, cUL Listed, FM Approved - Waterflow Detectors (2" VSR only), Vane Type, CSFM Listed

**Ball Valve:** UL Listed - Category VQGU, FM Approved

**AGF TestanDrain Model 1000:** UL Listed - Category VEHZ, FM Approved - Sprinkler System Alarm Testers

**AGF TestanDrain Model 1011 with Pressure Relief Valve:** UL Listed - Category VEHZ, FM Approved - Sprinkler System Alarm Testers

## 3. TECHNICAL DATA

### Specifications and Material Standards:

Available since 2007.

- Pressure Rating: 250 PSI (17.2 bar) maximum water working pressure.
- Fabricated steel pipe.
- Available in male NPT threaded inlet and outlet connections using Schedule 40 steel pipe.
- Available in grooved inlet and outlet connections using Schedule 10 steel pipe.
- Available with male NPT threaded inlet x grooved outlet using Schedule 40 steel pipe.
- Riser bodies coated with black Ecoat.
- Flow Switch: Two single-pole double-throw switches with Form C contacts rated at 15 Amps 125/250 V. AC, 2.5 Amp 0-30 V. DC. Each switch can be wired for open or closed circuit operation. See Figure 1.

### Ordering Information:

(Also refer to the current Viking price list.)

There are three different options available for the Residential line:

Basic Residential EasyPac Assemblies with Ball Valve Drain (See Figure 2)

Residential EasyPac Assemblies with TESTanDRAIN Valve (See Figure 3)

Residential EasyPac Assemblies with TESTanDRAIN and Pressure Relief Valve (PRV) (See Figure 4)

See Table 1 for Part Numbers.

## 4. INSTALLATION

Refer to appropriate NFPA Installation Standards.

**Note:** The EasyPac Residential Riser Manifold Assembly can be installed horizontally with flow switch on top, or vertically with flow upward.

Viking EasyPac Riser Assemblies use Potter VSR flow switches. The literature that accompanies the VSR states that the switch should not be installed within 6" of a change of direction of pipe or within 24" of a valve. This is merely a recommendation to reduce the possibility of the switch not operating while minimal waterflow is occurring. This is a recommendation only, not a requirement.

## 5. TESTANDRAIN VALVE OPERATING INSTRUCTIONS

1. To Test: Turn valve handle counterclockwise from "Off" to "Test". The handle will stop automatically. After test is completed, return handle to "Off".
2. To Drain: Turn handle counterclockwise from "Off" to "Test". The handle will stop automatically. Depress "Push" button and turn handle to "Drain". When system is empty, return handle clockwise to "Off" position.

## 6. INSPECTIONS, TESTS AND MAINTENANCE

Refer to NFPA 25 for Inspection, Testing and Maintenance requirements.



# TECHNICAL DATA

## EASYPAC RESIDENTIAL RISER MANIFOLD ASSEMBLIES 1" - 2" (DN25 - DN50)

The Viking Corporation, 210 N Industrial Park Drive, Hastings MI 49058

Telephone: 269-945-9501 Technical Services 877-384-5464 Fax: 269-818-1680 Email: techsvcs@vikingcorp.com

Visit the Viking website for the latest edition of this technical data page [www.vikinggroupinc.com](http://www.vikinggroupinc.com)

### 7. AVAILABILITY

The Viking EasyPac Riser Assemblies are available through a network of domestic and international distributors. See The Viking Corporation web site for the closest distributor or contact The Viking Corporation.

### 8. GUARANTEE

For details of warranty, refer to Viking's current list price schedule or contact Viking directly.

**Table 1 - Commercial EasyPac Assemblies**

Pipe Size	Inlet / Outlet Connections	Option	Pipe Size	Viking Part Number
1"	Thread / Thread	Ball Valve	Schedule 40	15226
		TESTanDRAIN		15227
		TESTanDRAIN and PRV		15228
	Groove / Groove	Ball Valve	Schedule 10	15243
		TESTanDRAIN		15244
		TESTanDRAIN and PRV		15245
1-1/4"	Thread / Thread	Ball Valve	Schedule 40	14840
		TESTanDRAIN		15229
		TESTanDRAIN and PRV		15230
	Groove / Groove	Ball Valve	Schedule 10	14841
		TESTanDRAIN		15231
		TESTanDRAIN and PRV		15232
	Thread / Groove	Ball Valve	Schedule 40	14905
		TESTanDRAIN		15233
		TESTanDRAIN and PRV		15234
1-1/2"	Thread / Thread	Ball Valve	Schedule 40	14842
		TESTanDRAIN		15235
		TESTanDRAIN and PRV		15236
	Groove / Groove	Ball Valve	Schedule 10	14843
		TESTanDRAIN		15237
		TESTanDRAIN and PRV		15238
	Thread / Groove	Ball Valve	Schedule 40	14849
		TESTanDRAIN		15239
		TESTanDRAIN and PRV		15240
2"	Thread / Thread	Ball Valve	Schedule 40	14844
		TESTanDRAIN		15241
		TESTanDRAIN and PRV		14901
	Groove / Groove	Ball Valve	Schedule 10	14845
		TESTanDRAIN		15242
		TESTanDRAIN and PRV		14900
	Thread / Groove	Ball Valve	Schedule 40	14846
		TESTanDRAIN		15246
		TESTanDRAIN and PRV		15247

#### **TESTanDRAIN Option:**

Includes a test orifice with size specified from 3/8" (K2.8) to 25K ESFR\*, depending on the smallest sprinkler installed on the system. Must add suffix to the part number for the desired orifice size.

#### **Orifice Suffix:**

A = 3/8" (K 2.8)  
B = 7/16" (K 4.2)  
C = 1/2" (K 5.6)  
D = 17/32" (K 8.0)

#### **TESTanDRAIN with PRV Option:**

Includes test orifice and pressure relief valve. The test orifice must be specified based on the smallest sprinkler installed on the system for 3/8" (K2.8) to K25 ESFR\*. The pressure relief valve is not factory assembled to the TestanDrain. Must add suffix to the part number for the desired orifice size and pressure setting of the pressure relief valve.

#### **Orifice Suffix:**

A = 3/8" (K 2.8)  
B = 7/16" (K 4.2)  
C = 1/2" (K 5.6)  
D = 17/32" (K 8.0)

#### **PRV Suffix:**

175  
185  
195  
205  
225  
250

**NOTE:** It is important to note that the pressure rating of the relief valve indicates an operating range of pressure for both opening and closing of the valve. Standard relief valves are required to OPEN in a range of pressure between 90% and 105% of their rating. The valves are required to CLOSE at a pressure above 80% of that rating.



# TECHNICAL DATA

## EASYPAC RESIDENTIAL RISER MANIFOLD ASSEMBLIES 1" - 2" (DN25 - DN50)

The Viking Corporation, 210 N Industrial Park Drive, Hastings MI 49058

Telephone: 269-945-9501 Technical Services 877-384-5464 Fax: 269-818-1680 Email: techsvcs@vikingcorp.com

Visit the Viking website for the latest edition of this technical data page [www.vikinggroupinc.com](http://www.vikinggroupinc.com)

	1"	1-1/4"	1-1/2"	2"
<b>Pipe OD</b>	1.315" (33.4 mm)	1.660" (42 mm)	1.900" (48 mm)	2.375" (60 mm)
<b>Schedule 10 Pipe ID</b>	1.097" (27.9 mm)	1.45" (36.6 mm)	1.69" (42.7 mm)	2.16" (54.8 mm)
<b>Schedule 40 Pipe ID</b>	1.049" (26.6 mm)	1.38" (35.1 mm)	1.61" (40.9 mm)	2.07" (52.5 mm)

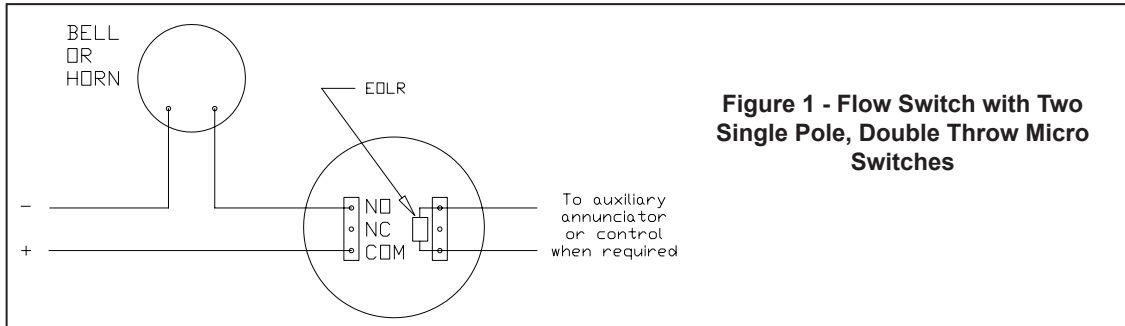



# TECHNICAL DATA

## EASYPAC RESIDENTIAL RISER MANIFOLD ASSEMBLIES 1" - 2" (DN25 - DN50)

The Viking Corporation, 210 N Industrial Park Drive, Hastings MI 49058

Telephone: 269-945-9501 Technical Services 877-384-5464 Fax: 269-818-1680 Email: techsvcs@vikingcorp.com

Visit the Viking website for the latest edition of this technical data page [www.vikinggroupinc.com](http://www.vikinggroupinc.com)

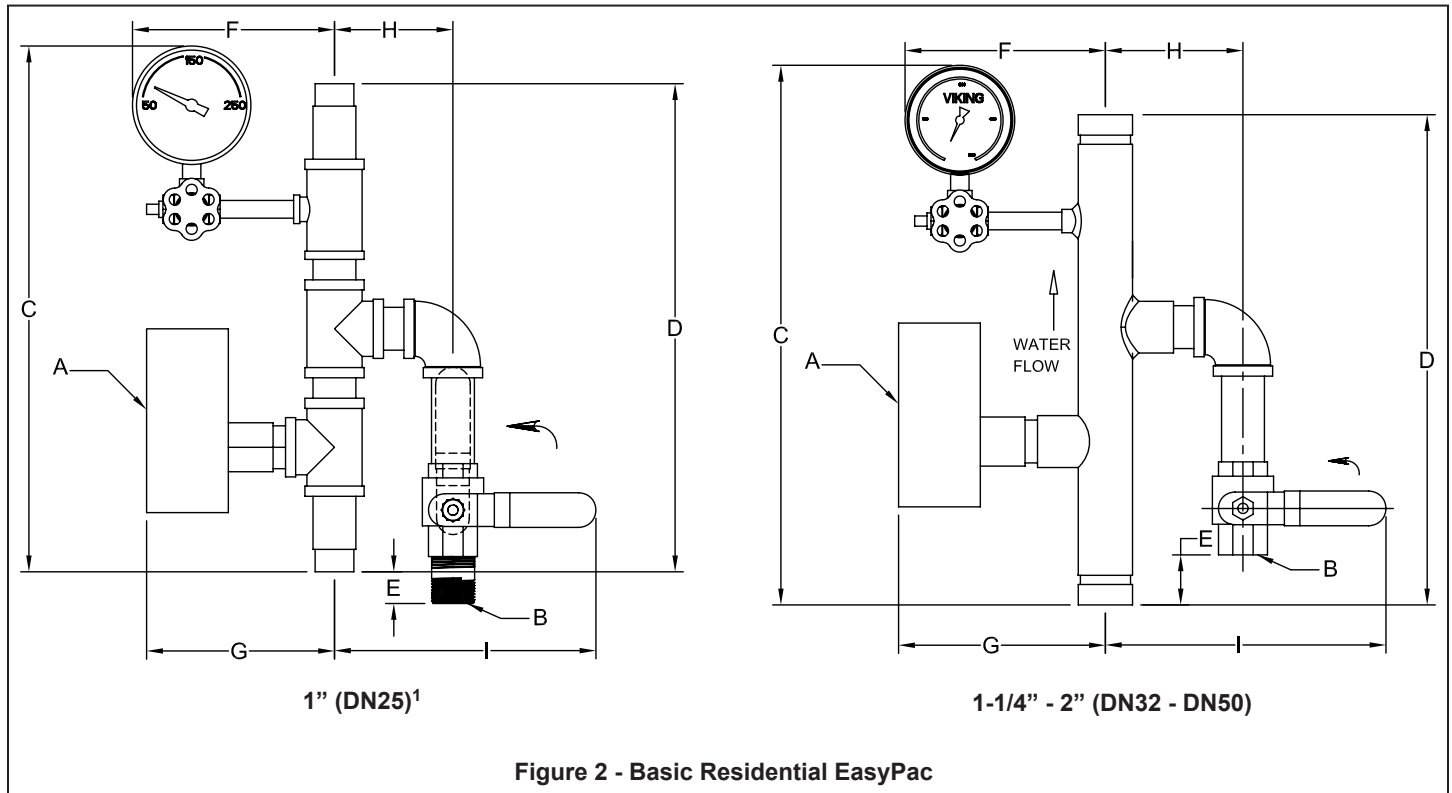

Size	A	B	C	D	E	F	G	H	I
<b>1" (DN25)<sup>1</sup></b>	VSR-S Flow Switch <sup>3</sup>	1" Hose	16-3/32" (409)	14-15/16" (379)	1" (25)	6-3/16" (157)	5-3/4" (146)	3-1/2" (89)	8" (203)
<b>1-1/4" (DN32)</b>	VSR-S Flow Switch <sup>3</sup>	1" NPT	16-1/2" (419)	15" (381)	1-1/2" (38)	6-3/32" (155)	6-11/32" (161)	4-3/16" (107)	8-9/16" (218)
<b>1-1/2" (DN40)</b>	VSR-S Flow Switch <sup>3</sup>	1" NPT	16-1/2" (419)	15" (381)	1-1/2" (38)	6-7/32" (158)	6-15/16" (164)	4-5/16" (110)	9-11/16" (246)
<b>2" (DN50)</b>	VSR Flow Switch <sup>4</sup>	1-1/4" NPT	14-1/2" (369)	13" (330)	-1/2" (-12) <sup>2</sup>	6-7/16" (164)	5-51/64" (148)	5" (127)	9-23/64" (238)

<sup>1</sup> The body of the 1" manifold is comprised of four 1" nipples and three tee's.

<sup>2</sup> Dimension E is negative because the ball valve extends below the end of the manifold body.

<sup>3</sup> Mounted with included nipple (As shown above)

<sup>4</sup> Mounted with included U bolt (Not Shown)

**Note: Dimensions may vary by  $\pm 1/4"$  (6.3 mm)**



# TECHNICAL DATA

## EASYPAC RESIDENTIAL RISER MANIFOLD ASSEMBLIES 1" - 2" (DN25 - DN50)

The Viking Corporation, 210 N Industrial Park Drive, Hastings MI 49058

Telephone: 269-945-9501 Technical Services 877-384-5464 Fax: 269-818-1680 Email: techsvcs@vikingcorp.com  
Visit the Viking website for the latest edition of this technical data page www.vikinggroupinc.com

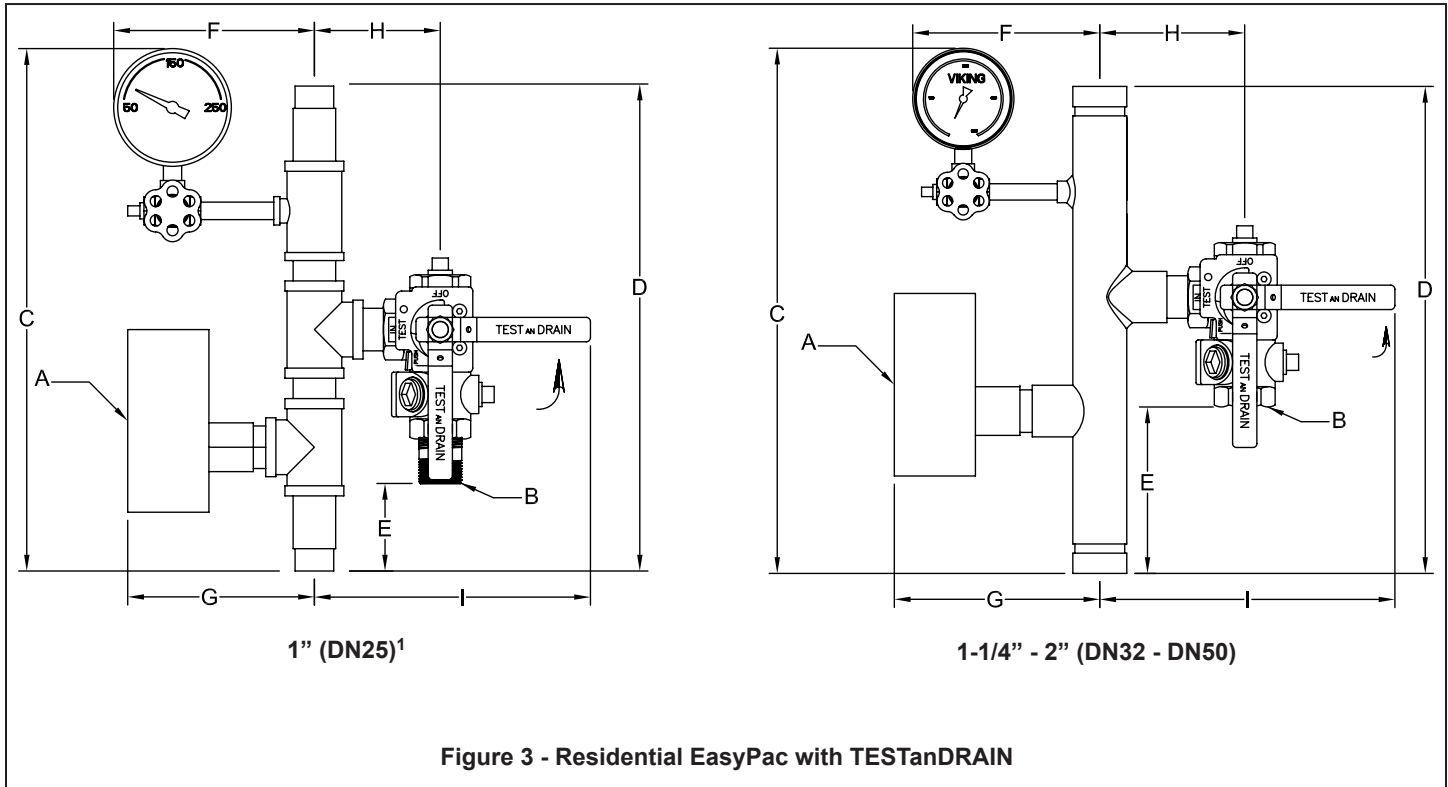

Size	A	B	C	D	E	F	G	H	I
<b>1" (DN25)<sup>1</sup></b>	VSR-S Flow Switch <sup>2</sup>	1" Hose	16-1/16" (409)	14-15/16" (379)	2-11/16" (68)	6-3/16" (157)	5-3/4" (146)	3-7/8" (98)	8-1/2" (216)
<b>1-1/4" (DN32)</b>	VSR-S Flow Switch <sup>2</sup>	1" NPT	16-1/2" (419)	15" (381)	5-1/8" (131)	6-3/32" (155)	6-11/32" (161)	4-15/32" (114)	9-3/32" (231)
<b>1-1/2" (DN40)</b>	VSR-S Flow Switch <sup>2</sup>	1" NPT	16-1/2" (419)	15" (381)	5-1/8" (131)	7-19/32" (193)	6-15/16" (164)	4-19/32" (117)	9-7/32" (234)
<b>2" (DN50)</b>	VSR Flow Switch <sup>3</sup>	1-1/4" NPT	14-1/2" (369)	13" (330)	3-1/4" (83)	6-7/16" (164)	5-51/64" (148")	5-13/64" (132)	10-45/64" (272)

<sup>1</sup> The body of the 1" manifold is comprised of four 1" nipples and three tee's.

<sup>2</sup> Mounted with included nipple (As shown above)

<sup>3</sup> Mounted with included U bolt (Not Shown)

**Note: Dimensions may vary by  $\pm 1/4"$  (6.3 mm)**



# TECHNICAL DATA

## EASYPAC RESIDENTIAL RISER MANIFOLD ASSEMBLIES 1" - 2" (DN25 - DN50)

The Viking Corporation, 210 N Industrial Park Drive, Hastings MI 49058

Telephone: 269-945-9501 Technical Services 877-384-5464 Fax: 269-818-1680 Email: techsvcs@vikingcorp.com

Visit the Viking website for the latest edition of this technical data page [www.vikinggroupinc.com](http://www.vikinggroupinc.com)

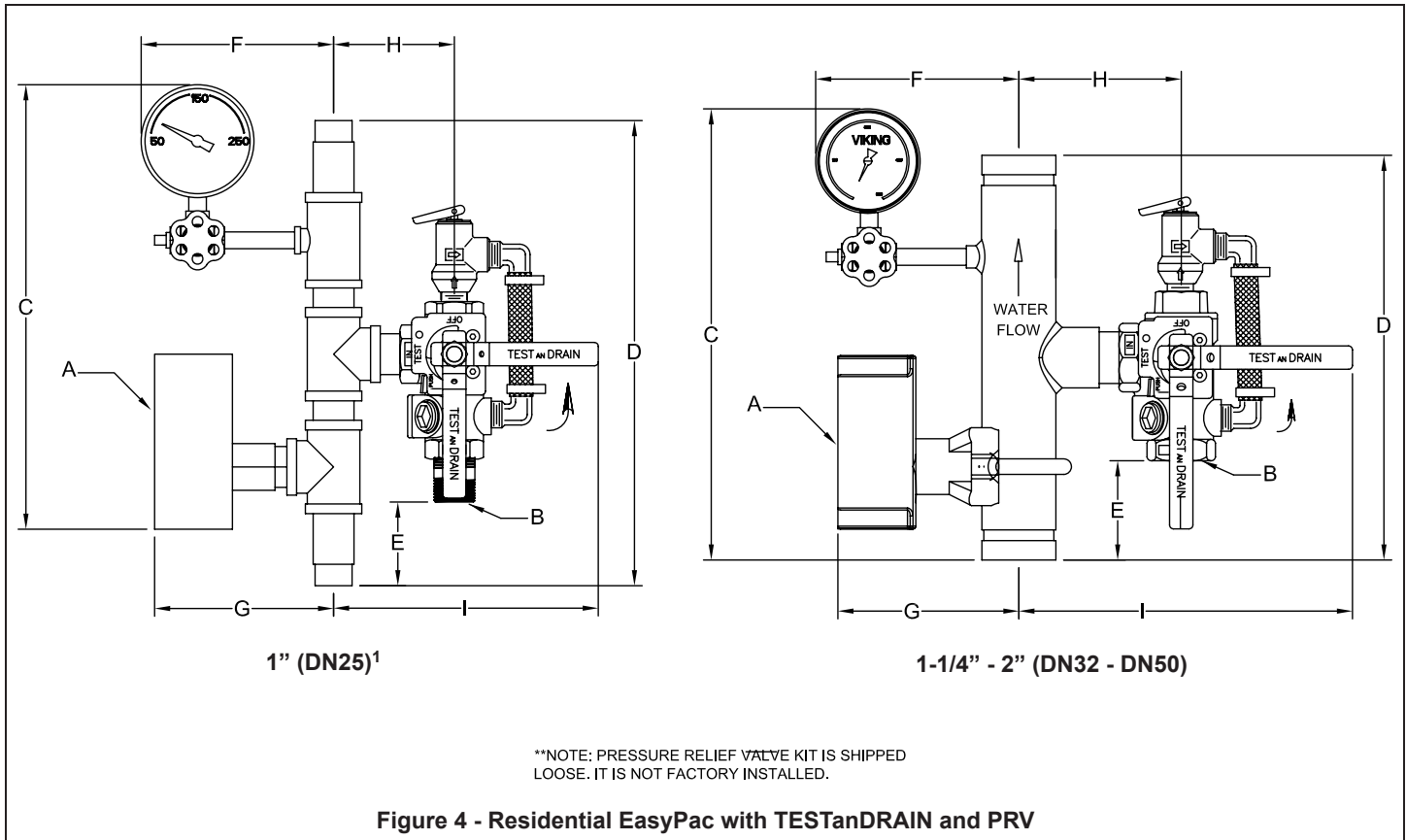

Size	A	B	C	D	E	F	G	H	I
<b>1" (DN25)<sup>1</sup></b>	VSR-S Flow Switch <sup>2</sup>	1" NPT	16-1/16" (409)	14-15/16" (379)	2-11/16" (68)	6-3/16" (157)	5-3/4" (146)	3-7/8" (98)	8-1/2" (216)
<b>1-1/4" (DN32)</b>	VSR-S Flow Switch <sup>2</sup>	1" NPT	16-1/2" (419)	15" (381)	5-1/8" (131)	6-3/32" (155)	6-11/32" (161)	4-15/32" (114)	9-3/32" (231)
<b>1-1/2" (DN40)</b>	VSR-S Flow Switch <sup>2</sup>	1" NPT	16-1/2" (419)	15" (381)	5-1/8" (131)	7-19/32" (193)	6-15/16" (164)	4-19/32" (117)	9-7/32" (234)
<b>2" (DN50)</b>	VSR Flow Switch <sup>3</sup>	1-1/4" NPT	14-1/2" (369)	13" (330)	3-1/4" (83)	6-7/16" (164)	5-51/64" (148")	5-13/64" (132)	10-45/64" (272)

<sup>1</sup> The body of the 1" manifold is comprised of four 1" nipples and three tee's.

<sup>2</sup> Mounted with included nipple (Not Shown)

<sup>3</sup> Mounted with included U bolt (As shown above)

**Note: Dimensions may vary by ± 1/4" (6.3 mm)**



Raleigh: 1609 Heritage Commerce Ct | Wake Forest, NC 27587 | Tel: 919.872.3250  
[www.SummitFireSecurity.com](http://www.SummitFireSecurity.com)

# HYDRAULIC CALCULATIONS





Raleigh: 1731 Roundrock Drive | Raleigh, NC 27615 | Tel: 919.872.3250  
[www.SummitFireSecurity.com](http://www.SummitFireSecurity.com)

4/5/2023

Test Date: 4/5/23

Time: 1:45 PM by Summit Fire & Security

Flow Location: Hydrant on Gallery Dr.

Residual Location: Hydrant on Gallery Dr.

Flow (GPM): 522 GPM

Static Pressure (PSI): 119

Residual Pressure (PSI): 110

Notes:

Underground is 8"

Diagram:

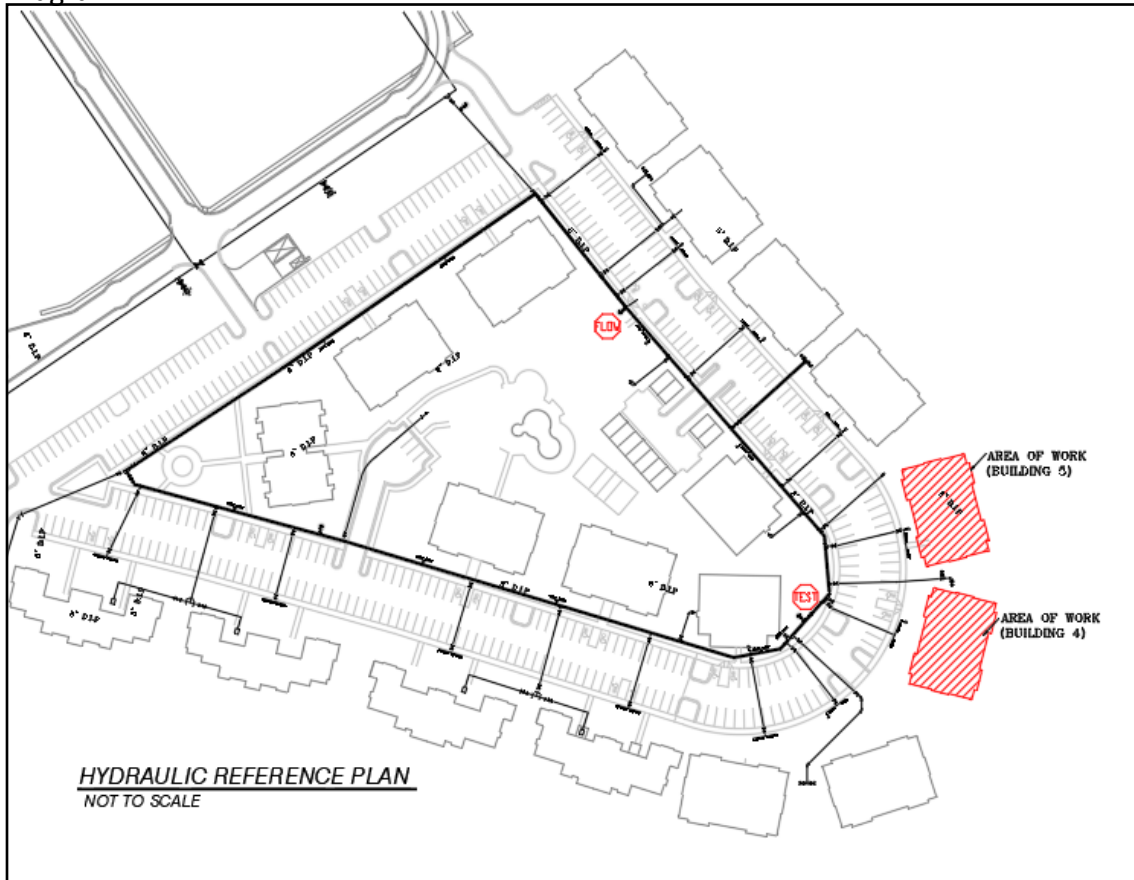



FC-PN175THD.2018.09.21.MA

# 1 3/4" PITOTLESS NOZZLE™

## PN1.75THD - GPM FLOW CHART

### THIS DEVICE IS FM APPROVED

The pressure vs. flow rate data developed within this flow chart is based on the average K-factor measured during laboratory testing. This data has been determined to be within the acceptable limitations for accuracy.

It is the user's responsibility to verify that the correct chart and column is being used.

#### HM2H | 2 1/2" Hose Monster Model II or Flusher with flow splitter (HM2H, HM2HF)

Use this column if the Pitotless Nozzle is connected to the 2 1/2" Hose Monster or Flusher. The built-in pitot or flow splitter must be installed for accuracy.

**OA | Open Atmosphere** - Use this column when the Pitotless Nozzle is connected directly to a test header or hydrant flowing openly to atmosphere.

Find this flow chart and other resources at:  
[hosemonster.com/resources](http://hosemonster.com/resources)

### GET THE MOST OUT OF YOUR HOSE MONSTER™ HARDWARE

#### FIRE PUMP TESTING SOFTWARE

Professional-grade software that helps you work better! Keep your reports clean, your results accurate, and your process streamlined with Hose Monster's FPT Software.

Learn more at: [www.hosemonster.com/fpts](http://www.hosemonster.com/fpts)

	HM2H	OA		HM2H	OA		HM2H	OA
PSI	GPM	GPM	PSI	GPM	GPM	PSI	GPM	GPM
5.2*		250	36	640	658	64	853	878
5.7*	250		37	648	667	65	859	884
10	337	347	38	657	676	66	866	891
11	354	364	39	666	685	67	873	898
12	369	380	40	674	694	68	879	905
13	384	396	41	683	702	69	885	911
14	399	410	42	691	711	70	892	918
15	413	425	43	699	719	71	898	924
16	426	439	44	707	728	72	905	931
17	440	452	45	715	736	73	911	937
18	452	465	46	723	744	74	917	944
19	465	478	47	731	752	75	923	950
20	477	491	48	739	760	76	929	956
21	489	503	49	746	768	77	935	963
22	500	515	50	754	776	78	941	969
23	511	526	51	761	783	79	947	975
24	522	537	52	769	791	80	953	981
25	533	549	53	776	799			
26	544	559	54	783	806			
27	554	570	55	791	814			
28	564	580	56	798	821			
29	574	591	57	805	828			
30	584	601	58	812	835			
31	594	611	59	819	843			
32	603	621	60	826	850			
33	612	630	61	833	857			
34	622	640	62	839	864			
35	631	649	63	846	871			

\* Special flow rate point determined to be within the acceptable limitations of accuracy.



**HOSE MONSTER**  
COMPANY

(888) 202-9987 (847) 434-0073 Service@FlowTest.com www.HoseMonster.com

MANUFACTURED BY THE HOSE MONSTER™ COMPANY

# PITOTLESS NOZZLE™

## THREADED INSTRUCTIONS

The Pitotless Nozzle™ Threaded (PN#THD) must be used in conjunction with the 2 ½” Hose Monster Model II (HM2H, HM2HF) or attached directly to a hydrant or test header valve discharging into open atmosphere.

*Note: If you intend to use the Pitotless Nozzle with the Little Hose Monster (HML), then a Pitotless Nozzle Grooved (PN#GRV) is required. Do not use the Pitotless Nozzle Threaded (PN#THD) with the Little Hose Monster. Call us if you are considering a configuration not listed here.*

## PITOTLESS NOZZLE™ SETUP

The gauge connection on the Pitotless Nozzle™ is a factory-installed male end of a quick disconnect coupling. One female counterpart is included and additional ones can be purchased separately. Attach the female end of the quick disconnect coupling directly to the gauge or remote reader adapter and use the quick disconnect feature to attach and remove. Do not remove the male quick disconnect from the Pitotless Nozzle as it will damage the threads on the Pitotless Nozzle.

We recommend a gauge with an accuracy rating of ½% or better and of a suitable range.

## PITOTLESS NOZZLE™ USE

### WITH THE MODEL II, 2 ½ HOSE MONSTER™ OR FLUSHER

Insert the male outlet of the Pitotless Nozzle into the swivel coupling of the Hose Monster. Hand-tighten plus about a quarter -turn using a rocker lug spanner wrench on the swivel coupling and a pin lug spanner wrench (WSPA104) for a holdback on the Pitotless Nozzle. Attach the male end of a hose into the swivel coupling on the Pitotless Nozzle, hand-tighten plus about a quarter turn using spanner wrenches. The pitot / flow splitter must remain on either unit in order to collect accurate flow rates. Make sure the hose lays flat and is not twisted.

### ON A HYDRANT OR TEST HEADER VALVE

The Pitotless Nozzle must be attached securely to a pump test header valve or hydrant. Secure the female swivel coupling of the Pitotless Nozzle directly to a hydrant nozzle or test header valve. The Pitotless Nozzle points in the direction the water will flow. Clear water discharge path.

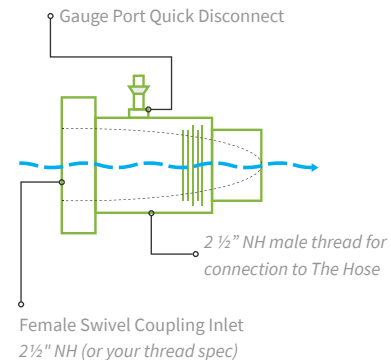

## WARNING

- Do not attach the Pitotless Nozzle™ to the end of a hose unless the Hose Monster is attached or it is permanently secured.
- Do not attach a hose to the male outlet end of the Pitotless Nozzle™ under any circumstance. The backpressure will distort flow rate reading.
- Do not remove the gauge port quick disconnect fitting. The aluminum threads will be damaged. Contact Hose Monster™ for any repairs.

	LHM	OA		LHM	OA
PSI	GPM	GPM	PSI	GPM	GPM
10	533	282	41	1080	570
11	559	295	42	1093	577
12	584	308	43	1106	584
13	608	321	44	1119	591
14	631	333	45	1131	597
15	653	345	46	1144	604
16	675	356	47	1156	610
17	695	367	48	1169	617
18	716	378	49	1181	623
19	735	388	50	1193	630
20	754	398	51	1205	636
21	773	408	52	1216	642
22	791	418	53	1228	648
23	809	427	54	1239	654
24	826	436	55	1250	660

## FLOW CHARTS

Pitotless Nozzle™ flow charts must be used to determine discharge flow rate. The use of flow charts of a different device or size will result in incorrect readings. Within the flow chart is a column for “Little Hose Monster” and for “Open Atmosphere”. Use the “Little Hose Monster” flows if the Pitotless Nozzle™ is attached to a Little Hose Monster. Use the “Open Atmosphere” flows if the Pitotless Nozzle™ is attached directly to a hydrant or test header valve discharging out into the open.

Flow charts are provided with the Pitotless Nozzle and additional copies are available on our website at [www.hosemonster.com](http://www.hosemonster.com)





## Hydraulic Calculations by HydraCALC

SUMMIT FIRE SECURITY  
1609 HERITAGE COMMERCE CT  
WAKE FOREST NC 27587  
919-872-3250

Job Name : FAIRWAY POINTE BLDG 13  
Drawing : FP4  
Location : 200 GALLERY DR SPRING LAKE NC 28390  
Remote Area : RA3  
Contract : 1-5046-00326  
Data File : RA3 BLDG 2 BREEZEWAY.WXF

---

**HYDRAULIC CALCULATIONS**  
**for**

**JOB NAME** FAIRWAY POINTE BLDG 13  
**Location** 200 GALLERY DR SPRING LAKE NC 28390  
**Drawing #** FP4  
**Contract #** 1-5046-00326  
**Date** 9/8/23

**DESIGN**

**Remote area #** RA3  
**Remote area location** BLDG 13 BREEZEWAY  
**Occupancy classification** LH  
**Density** .1 - Gpm/SqFt  
**Area of application** ENTIRE - SqFt  
**Coverage/sprinkler** VARIES - SqFt  
**Type of sprinkler calculated** DRY SIDEWALL  
**# Sprinklers calculated** 4  
**In-rack demand** - GPM  
**Hose streams** - GPM  
**Total water required (including hose streams)** 67.2035 - GPM @ 52.3044 - Psi  
**Type of system** WET  
**Volume of system (dry or pre-action)** - Gal

**WATER SUPPLY INFORMATION**

**Test date** 4/5/23  
**Location** GALLERY DR  
**Source of info** SUMMIT FIRE & SECURITY

**CONTRACTOR INFO** SUMMIT FIRE SECURITY  
**Address** 1609 HERITAGE COMMERCE CT WAKE FOREST NC  
**Phone #** 919-872-3250  
**Name of designer** I. BURROWS  
**Authority having jurisdiction** HARNETT COUNTY  
**NOTES:**

text1(35) - invisible

# Water Supply Curve

SUMMIT FIRE SECURITY  
FAIRWAY POINTE BLDG 13

Page 2  
Date 9/8/23

City Water Supply:  
C1 - Static Pressure : 119  
C2 - Residual Pressure: 110  
C2 - Residual Flow : 522

Demand:  
D1 - Elevation : 9.095  
D2 - System Flow : 67.204  
D2 - System Pressure : 52.304  
Hose ( Demand ) : \_\_\_\_\_  
D3 - System Demand : 67.204  
Safety Margin : 66.493

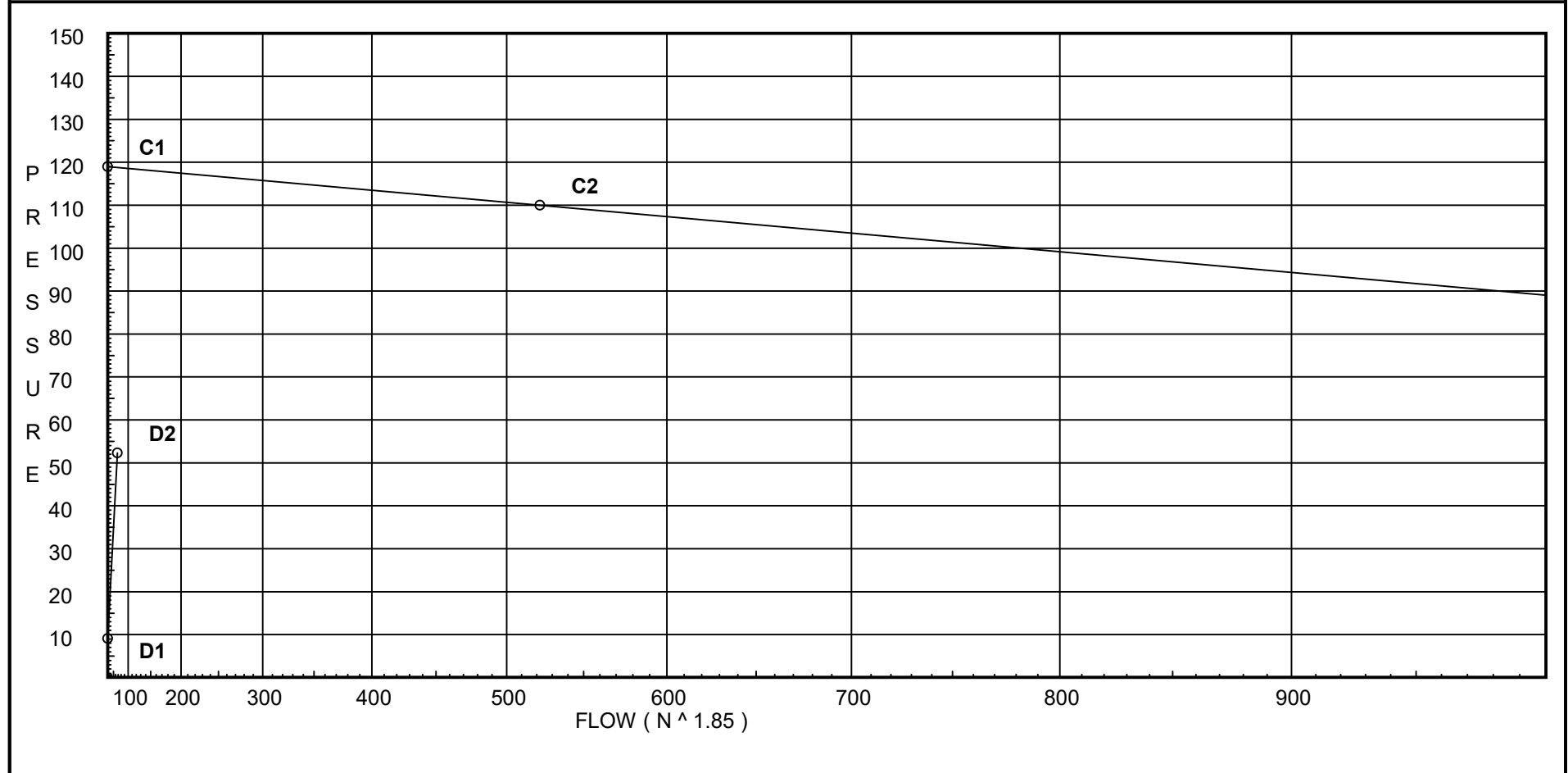

# Fittings Used Summary

SUMMIT FIRE SECURITY  
FAIRWAY POINTE BLDG 13

Page 3  
Date 9/8/23

## Fitting Legend

Abbrev.	Name	1/2	3/4	1	1 1/4	1 1/2	2	2 1/2	3	3 1/2	4	5	6	8	10	12	14	16	18	20	24
E	NFPA 13 90' Standard Elbow	1	2	2	3	4	5	6	7	8	10	12	14	18	22	27	35	40	45	50	61
F	NFPA 13 45' Elbow	1	1	1	1	2	2	3	3	3	4	5	7	9	11	13	17	19	21	24	28
Fsp	Flow Switch Potter VSR	Fitting generates a Fixed Loss Based on Flow																			
G	NFPA 13 Gate Valve	0	0	0	0	0	1	1	1	1	2	2	3	4	5	6	7	8	10	11	13
H	45' Grvd-Vic Elbow #11	0	0	1	1.5	2	2	3	3	3.5	3.5	4.5	5	6.5	8.5	10	18	20	23	25	30
N *	CPVC 90' Ell	0	4	5	6	7	9	12	13	0	0	0	0	0	0	0	0	0	0	0	0
O *	CPVC Branch Tee	0	3	5	6	8	10	12	15	0	0	0	0	0	0	0	0	0	0	0	0
T	NFPA 13 90' Flow thru Tee	3	4	5	6	8	10	12	15	17	20	25	30	35	50	60	71	81	91	101	121

## Units Summary

Diameter Units	Inches
Length Units	Feet
Flow Units	US Gallons per Minute
Pressure Units	Pounds per Square Inch

Note: Fitting Legend provides equivalent pipe lengths for fittings types of various diameters. Equivalent lengths shown are standard for actual diameters of Sched 40 pipe and CFactors of 120 except as noted with \*. The fittings marked with a \* show equivalent lengths values supplied by manufacturers based on specific pipe diameters and CFactors and they require no adjustment. All values for fittings not marked with a \* will be adjusted in the calculation for CFactors of other than 120 and diameters other than Sched 40 per NFPA.

**SUPPLY ANALYSIS**

<b>Node at Source</b>	<b>Static Pressure</b>	<b>Residual Pressure</b>	<b>Flow</b>	<b>Available Pressure</b>	<b>Total Demand</b>	<b>Required Pressure</b>
TEST	119.0	110	522.0	118.797	67.2	52.304

**NODE ANALYSIS**

<b>Node Tag</b>	<b>Elevation</b>	<b>Node Type</b>	<b>Pressure at Node</b>	<b>Discharge at Node</b>	<b>Notes</b>
S301	131.0	5.6	8.37	16.21	0.1 150
S302	131.0	5.6	11.6	19.07	0.1 150
S303	131.0	5.6	9.13	16.92	0.1 150
S304	131.0	5.6	7.17	15.0	0.1 150
301	131.0		13.44		
302	131.0		17.42		
203	131.0		11.98		
304	131.0		10.1		
X2	120.0		18.96		
X1	120.0		17.27		
M3	120.0		17.27		
X	120.0		21.03		
X3	120.0		24.22		
M5	120.0		25.05		
X4	120.0		24.67		
X5	120.0		24.66		
C	112.0		28.29		
E	112.0		29.2		
TOR	112.0		32.43		
BKFL	105.0		38.77		
BASE	101.0		54.91		
UG1	101.0		55.32		
UG2	97.5		57.47		
UG3	110.0		52.3		
UG4	110.0		52.3		
UG5	110.0		52.3		
UGT	110.0		52.3		
TEST	110.0		52.3		



# Final Calculations : Hazen-Williams

SUMMIT FIRE SECURITY  
FAIRWAY POINTE BLDG 13

Page 5  
Date 9/8/23

Node1 to Node2	Elev1 Elev2	K Fact	Qa Qt	Nom Act	Fitting or Eqiv	Len	Pipe Ftngs Total	CFact Pf/Ft	Pt Pe Pf	*****	Notes	*****
S301 to 301	131 131	5.60	16.21 16.21	0.75 0.874	2N	8.0	27.667 8.000 35.667	150	8.375 0.0 5.063		Vel = 8.67	
301			0.0 16.21						13.438		K Factor = 4.42	
S302 to 302	131 131	5.60	19.07 19.07	0.75 0.874	3N O	12.0 3.0	15.333 15.000 30.333	150	11.602 0.0 5.820		Vel = 10.20	
302			0.0 19.07						17.422		K Factor = 4.57	
S303 to 203	131 131	5.60	16.92 16.92	0.75 0.874	3N	12.0	6.500 12.000 18.500	150	9.133 0.0 2.845		Vel = 9.05	
203			0.0 16.92						11.978		K Factor = 4.89	
S304 to 304	131 131	5.60	15.00 15.0	0.75 0.874	2N	8.0	15.750 8.000 23.750	150	7.175 0.0 2.921		Vel = 8.02	
304			0.0 15.00						10.096		K Factor = 4.72	
301 to X2	131 120		16.21 16.21	0.75 0.874	O	3.0	2.375 3.000 5.375	150	13.438 4.764 0.762		Vel = 8.67	
X2			0.0 16.21						18.964		K Factor = 3.72	
302 to X3	131 120		19.07 19.07	0.75 0.874	N O	4.0 3.0	3.583 7.000 10.583	150	17.422 4.764 2.031		Vel = 10.20	
X3			0.0 19.07						24.217		K Factor = 3.88	
203 to M3	131 120		16.92 16.92	0.75 0.874	O	3.0	0.417 3.000 3.417	150	11.978 4.764 0.525		Vel = 9.05	
M3			0.0 16.92						17.267		K Factor = 4.07	
304 to X1	131 120		15.00 15.0	0.75 0.874	N O	4.0 3.0	12.583 7.000 19.583	150	10.096 4.764 2.410		Vel = 8.02	
X1			0.0 15.00						17.270		K Factor = 3.61	
X2 to X1	120 120		-16.24 -16.24	1 1.101	N O	5.0 5.0	26.625 10.000 36.625	150	18.964 0.0 -1.694		Vel = 5.47	
X1 to M3	120 120		15.00 -1.24	1 1.101	N	5.0	1.417 5.000 6.417	150	17.270 0.0 -0.003		Vel = 0.42	
M3 to X	120 120		16.93 15.69	1 1.101	2N	10.0	76.583 10.000 86.583	150	17.267 0.0 3.758		Vel = 5.29	

# Final Calculations : Hazen-Williams

SUMMIT FIRE SECURITY  
FAIRWAY POINTE BLDG 13

Page 6  
Date 9/8/23

Node1 to Node2	Elev1 Elev2	K Fact	Qa Qt	Nom Act	Fitting or Equiv Len	Pipe Ftngs Total	CFact Pf/Ft	Pt Pe Pf	*****	Notes	*****
X to X2	120 120		-48.13 -32.44	1 1.101	N 5.0	7.375 5.000 12.375	150 -0.1665	21.025 0.0 -2.061			Vel = 10.93
X2			0.0 -32.44					18.964			K Factor = -7.45
X3 to M5	120 120		12.29 12.29	1 1.101	N 5.0	25.250 5.000 30.250	150 0.0276	24.217 0.0 0.836			Vel = 4.14
M5			0.0 12.29					25.053			K Factor = 2.46
M5 to X4	120 120		-6.78 -6.78	1 1.101	N 5.0	37.083 5.000 42.083	150 -0.0092	25.053 0.0 -0.387			Vel = 2.28
X4 to X5	120 120		0.0 -6.78	2 2.003		13.417 13.417	150 -0.0005	24.666 0.0 -0.007			Vel = 0.69
X5 to X3	120 120		0.0 -6.78	1 1.101	2N 10.0	38.125 10.000 48.125	150 -0.0092	24.659 0.0 -0.442			Vel = 2.28
X3			0.0 -6.78					24.217			K Factor = -1.38
M5 to E	120 112		19.07 19.07	1 1.101		11.000 11.000	150 0.0624	25.053 3.465 0.686			Vel = 6.43
E			0.0 19.07					29.204			K Factor = 3.53
X to C	120 112		48.13 48.13	1 1.101		11.000 11.000	150 0.3454	21.025 3.465 3.799			Vel = 16.22
C			0.0 48.13					28.289			K Factor = 9.05
C to E	112 112		48.13 48.13	2 2.003	O 10.0	38.792 10.000 48.792	150 0.0188	28.289 0.0 0.915			Vel = 4.90
E to TOR	112 112		19.07 67.2	2 2.003	4N 36.0	56.749 36.000 92.749	150 0.0347	29.204 0.0 3.222			Vel = 6.84
TOR			0.0 67.20					32.426			K Factor = 11.80
TOR to BKFL	112 105		67.20 67.2	2 2.067	Fsp 0.0	7.000 7.000	120 0.0450	32.426 6.032 0.315		** Fixed Loss = 3	Vel = 6.43
BKFL to BASE	105 101		0.0 67.2	2 2.067	E 5.0	4.000 5.000 9.000	120 0.0451	38.773 15.732 0.406		** Fixed Loss = 14	Vel = 6.43
BASE			0.0 67.20					54.911			K Factor = 9.07

# Final Calculations : Hazen-Williams

SUMMIT FIRE SECURITY  
FAIRWAY POINTE BLDG 13

Page 7  
Date 9/8/23

Node1 to Node2	Elev1 Elev2	K Fact	Qa Qt	Nom Act	Fitting or Eqiv	Len	Pipe Ftngs Total	CFact Pf/Ft	Pt Pe Pf	*****	Notes	*****
BASE to UG1	101 101		67.20 67.2	2 1.985	E	6.204	5.000 6.203 11.203	150 0.0362	54.911 0.0 0.406			Vel = 6.97
UG1 to UG2	101 97.500		0.0 67.2	2 1.985	E G	6.204 1.241	10.000 7.444 17.444	150 0.0363	55.317 1.516 0.633			Vel = 6.97
UG2 to UG3	97.500 110		0.0 67.2	4 4.23	E 2T G 3H	19.223 76.893 3.845 20.184	150.000 120.145 270.145	150 0.0009	57.466 -5.414 0.247			Vel = 1.53
UG3 to UGT	110 110		-10.69 56.51	8 8.27	G T	6.326 55.354	30.000 61.680 91.680	140 0	52.299 0.0 0.003			Vel = 0.34
UGT			0.0 56.51						52.302			K Factor = 7.81
UG3 to UG4	110 110		10.70 10.7	8 8.27	4F	56.936	750.000 56.936 806.936	140 0	52.299 0.0 0.001			Vel = 0.06
UG4 to UG5	110 110		0.0 10.7	8 8.27	F 2T	14.234 110.709	500.000 124.943 624.943	140 0	52.300 0.0 0.001			Vel = 0.06
UG5 to UGT	110 110		0.0 10.7	8 8.27	G T	6.326 55.354	500.000 61.680 561.680	140 0	52.301 0.0 0.001			Vel = 0.06
UGT to TEST	110 110		56.50 67.2	8 8.27	G T	6.326 55.354	10.000 61.680 71.680	140 0	52.302 0.0 0.002			Vel = 0.40
TEST			0.0 67.20						52.304			K Factor = 9.29



## Hydraulic Calculations by HydraCALC

SUMMIT FIRE SECURITY  
1609 HERITAGE COMMERCE CT  
WAKE FOREST NC 27587  
919-872-3250

Job Name : FAIRWAY POINT BLDG 13  
Drawing : FP2  
Location : 200 GALLERY DR SPRING LAKE NC 28390  
Remote Area : RA1  
Contract : 1-5046-00326  
Data File : RA1 BLDG 2 STORAGE.WXF

---

**HYDRAULIC CALCULATIONS**  
*for*

**JOB NAME** FAIRWAY POINTE BLDG 13  
**Location** 200 GALLERY DR SPRING LAKE NC 28390  
**Drawing #** FP2  
**Contract #** 1-5046-00326  
**Date** 9/8/23

**DESIGN**

**Remote area #** RA1  
**Remote area location** BLDG 13 STORAGE LEVEL 1  
**Occupancy classification** OHI  
**Density** .15 - Gpm/SqFt  
**Area of application** ENTIRE - SqFt  
**Coverage/sprinkler** VARIES - SqFt  
**Type of sprinkler calculated** SSP  
**# Sprinklers calculated** 11  
**In-rack demand** - GPM  
**Hose streams** 250 - GPM  
**Total water required (including hose streams)** 436.61 - GPM @ 87.6797 - Psi  
**Type of system** WET  
**Volume of system (dry or pre-action)** - Gal

**WATER SUPPLY INFORMATION**

**Test date** 4/5/23  
**Location** GALLERY DR.  
**Source of info** SUMMIT FIRE & SECURITY

**CONTRACTOR INFO** SUMMIT FIRE SECURITY  
**Address** 1609 HERITAGE COMMERCE CT WAKE FOREST NC  
**Phone #** 919-872-3250  
**Name of designer** I. BURROWS  
**Authority having jurisdiction** HARNETT COUNTY  
**NOTES:**

text1(35) - invisible

# Water Supply Curve

SUMMIT FIRE SECURITY  
FAIRWAY POINT BLDG 13

Page 2  
Date 9/8/23

City Water Supply:  
C1 - Static Pressure : 119  
C2 - Residual Pressure: 110  
C2 - Residual Flow : 522

Demand:  
D1 - Elevation : 0.866  
D2 - System Flow : 186.61  
D2 - System Pressure : 87.680  
Hose ( Demand ) : 250  
D3 - System Demand : 436.61  
Safety Margin : 24.853

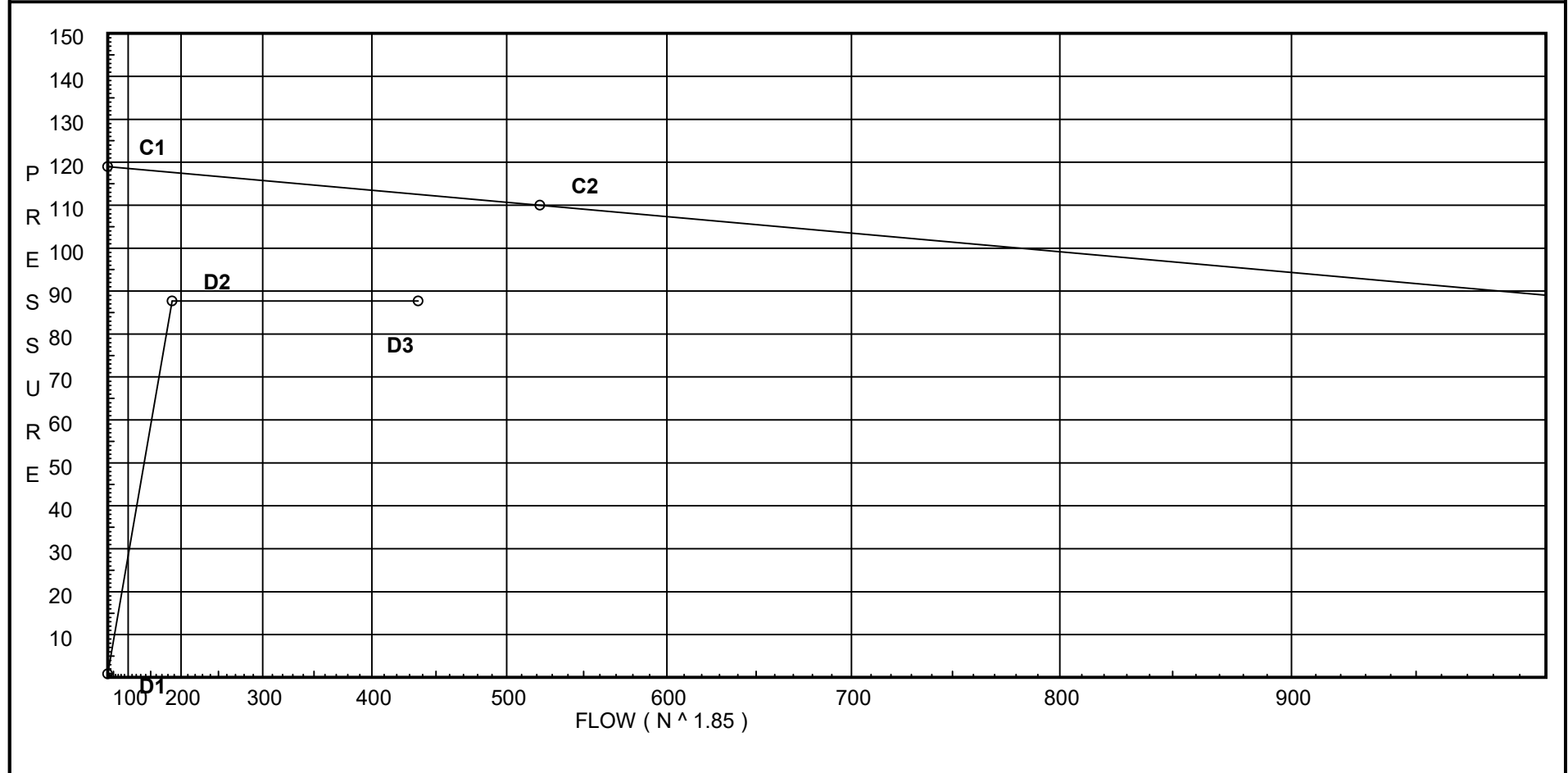

# Fittings Used Summary

SUMMIT FIRE SECURITY  
FAIRWAY POINT BLDG 13

Page 3  
Date 9/8/23

## Fitting Legend

Abbrev.	Name	1/2	3/4	1	1 1/4	1 1/2	2	2 1/2	3	3 1/2	4	5	6	8	10	12	14	16	18	20	24
E	NFPA 13 90' Standard Elbow	1	2	2	3	4	5	6	7	8	10	12	14	18	22	27	35	40	45	50	61
F	NFPA 13 45' Elbow	1	1	1	1	2	2	3	3	3	4	5	7	9	11	13	17	19	21	24	28
Fsp	Flow Switch Potter VSR	Fitting generates a Fixed Loss Based on Flow																			
G	NFPA 13 Gate Valve	0	0	0	0	0	1	1	1	1	2	2	3	4	5	6	7	8	10	11	13
H	45' Grvd-Vic Elbow #11	0	0	1	1.5	2	2	3	3	3.5	3.5	4.5	5	6.5	8.5	10	18	20	23	25	30
N *	CPVC 90' Ell	0	4	5	6	7	9	12	13	0	0	0	0	0	0	0	0	0	0	0	0
O *	CPVC Branch Tee	0	3	5	6	8	10	12	15	0	0	0	0	0	0	0	0	0	0	0	0
T	NFPA 13 90' Flow thru Tee	3	4	5	6	8	10	12	15	17	20	25	30	35	50	60	71	81	91	101	121

## Units Summary

Diameter Units	Inches
Length Units	Feet
Flow Units	US Gallons per Minute
Pressure Units	Pounds per Square Inch

Note: Fitting Legend provides equivalent pipe lengths for fittings types of various diameters. Equivalent lengths shown are standard for actual diameters of Sched 40 pipe and CFactors of 120 except as noted with \*. The fittings marked with a \* show equivalent lengths values supplied by manufacturers based on specific pipe diameters and CFactors and they require no adjustment. All values for fittings not marked with a \* will be adjusted in the calculation for CFactors of other than 120 and diameters other than Sched 40 per NFPA.

**SUPPLY ANALYSIS**

<i>Node at Source</i>	<i>Static Pressure</i>	<i>Residual Pressure</i>	<i>Flow</i>	<i>Available Pressure</i>	<i>Total Demand</i>	<i>Required Pressure</i>
TEST	119.0	110	522.0	112.533	436.61	87.68

**NODE ANALYSIS**

<i>Node Tag</i>	<i>Elevation</i>	<i>Node Type</i>	<i>Pressure at Node</i>	<i>Discharge at Node</i>	<i>Notes</i>
S101	112.0	5.6	7.63	15.47	0.15 96
S102	112.0	5.6	7.0	14.82	0.15 96
S103	112.0	5.6	7.84	15.68	0.15 50
S104	112.0	5.6	9.12	16.91	0.15 69
S105	112.0	5.6	7.98	15.81	0.15 96
S106	112.0	5.6	7.61	15.45	0.15 96
S107	112.0	5.6	8.69	16.51	0.15 66
S108	112.0	5.6	9.06	16.85	0.15 66
S109	112.0	5.6	10.92	18.51	0.15 53
S110	112.0	5.6	11.8	19.24	0.15 85
S111	112.0	5.6	14.55	21.36	0.15 55
101	112.0		8.95		
102	112.0		9.6		
103	112.0		10.34		
104	112.0		9.55		
105	112.0		10.59		
106	112.0		13.68		
107	112.0		15.49		
A	112.0		22.51		
B	112.0		23.4		
D	112.0		26.35		
TOR	112.0		56.5		
BKFL	105.0		64.62		
BASE	101.0		83.03		
UG1	101.0		85.72		
UG2	97.5		91.43		
UG3	110.0		87.64		
UG4	110.0		87.65		
UG5	110.0		87.66		
UGT	110.0		87.66		
TEST	110.0		87.68	250.0	



# Final Calculations : Hazen-Williams

SUMMIT FIRE SECURITY  
FAIRWAY POINT BLDG 13

Page 5  
Date 9/8/23

Node1 to Node2	Elev1 Elev2	K Fact	Qa Qt	Nom Act	Fitting or Eqiv	Len	Pipe Ftngs Total	CFact Pf/Ft	Pt Pe Pf	*****	Notes	*****
S101 to 101	112 112	5.60	15.47 15.47	0.75 0.874	2N	8.0	2.167 8.000 10.167	150	7.630 0.0 1.324		Vel = 8.27	
101			0.0 15.47						8.954		K Factor = 5.17	
S102 to 101	112 112	5.60	14.82 14.82	0.75 0.874	2N	8.0	8.250 8.000 16.250	150	7.000 0.0 1.954		Vel = 7.93	
101			0.0 14.82						8.954		K Factor = 4.95	
S103 to 102	112 112	5.60	15.68 15.68	0.75 0.874	N O	4.0 3.0	6.125 7.000 13.125	150	7.842 0.0 1.753		Vel = 8.39	
102			0.0 15.68						9.595		K Factor = 5.06	
S104 to 103	112 112	5.60	16.91 16.91	0.75 0.874	O N	3.0 4.0	0.917 7.000 7.917	150	9.120 0.0 1.216		Vel = 9.04	
103			0.0 16.91						10.336		K Factor = 5.26	
S105 to 104	112 112	5.60	15.81 15.81	0.75 0.874	2N	8.0	3.583 8.000 11.583	150	7.976 0.0 1.571		Vel = 8.45	
104			0.0 15.81						9.547		K Factor = 5.12	
S106 to 104	112 112	5.60	15.45 15.45	0.75 0.874	2N	8.0	6.875 8.000 14.875	150	7.614 0.0 1.933		Vel = 8.26	
104			0.0 15.45						9.547		K Factor = 5.00	
S107 to 105	112 112	5.60	16.51 16.51	0.75 0.874	N O	4.0 3.0	5.958 7.000 12.958	150	8.687 0.0 1.903		Vel = 8.83	
105			0.0 16.51						10.590		K Factor = 5.07	
S108 to 105	112 112	5.60	16.85 16.85	0.75 0.874	N	4.0	6.042 4.000 10.042	150	9.058 0.0 1.532		Vel = 9.01	
105			0.0 16.85						10.590		K Factor = 5.18	
S109 to 106	112 112	5.60	18.51 18.51	0.75 0.874	2N	8.0	7.167 8.000 15.167	150	10.924 0.0 2.753		Vel = 9.90	
106			0.0 18.51						13.677		K Factor = 5.01	
S110 to 106	112 112	5.60	19.24 19.24	0.75 0.874	2N	8.0	1.625 8.000 9.625	150	11.801 0.0 1.876		Vel = 10.29	

# Final Calculations : Hazen-Williams

SUMMIT FIRE SECURITY  
FAIRWAY POINT BLDG 13

Page 6  
Date 9/8/23

Node1 to Node2	Elev1 Elev2	K Fact	Qa Qt	Nom Act	Fitting or Eqiv	Len	Pipe Ftngs Total	CFact Pf/Ft	Pt Pe Pf	*****	Notes	*****
106			0.0 19.24						13.677		K Factor = 5.20	
S111 to 107	112 112	5.60	21.36	0.75	O	3.0	1.000 3.000 4.000	150	14.548 0.0			Vel = 11.42
107			0.0 21.36						15.495		K Factor = 5.43	
101 to 102	112 112		30.28	1			4.375	150	8.954 0.0			Vel = 10.20
102 to 103	112 112		30.28	1.101			4.375	0.1465	0.641			Vel = 10.20
102 to 103	112 112		15.69	1			2.333	150	9.595 0.0			Vel = 15.49
103 to A	112 112		45.97	1.101			2.333	0.3176	0.741			Vel = 15.49
103 to A	112 112		16.91	1	O	5.0	16.500 5.000 21.500	150	10.336 0.0			Vel = 21.19
A			0.0 62.88						22.512		K Factor = 13.25	
104 to 105	112 112		31.27	1			6.708	150	9.547 0.0			Vel = 10.54
105 to B	112 112		31.27	1.101			6.708	0.1555	1.043			Vel = 10.54
105 to B	112 112		33.36	1	O	5.0	16.500 5.000 21.500	150	10.590 0.0			Vel = 21.78
B			0.0 64.63						23.400		K Factor = 13.36	
106 to 107	112 112		37.75	1			8.250	150	13.677 0.0			Vel = 12.72
107 to D	112 112		37.75	1.101			8.250	0.2204	1.818			Vel = 12.72
107 to D	112 112		21.36	1	O	5.0	16.500 5.000 21.500	150	15.495 0.0			Vel = 19.92
D			0.0 59.11						26.354		K Factor = 11.51	
A to B	112 112		62.88	2	O	10.0	18.917 10.000 28.917	150	22.512 0.0			Vel = 6.40
B to D	112 112		62.88	2.003			28.917	0.0307	0.888			Vel = 6.40
B to D	112 112		64.62	2	O	10.0	16.000 10.000 26.000	150	23.400 0.0			Vel = 12.98
D to TOR	112 112		127.5	2.003			26.000	0.1136	2.954			Vel = 12.98
D to TOR	112 112		59.11	2	4N O	36.0 10.0	85.166 46.000 131.166	150	26.354 0.0			Vel = 19.00
TOR			0.0 186.61						30.147		K Factor = 24.83	
TOR to BKFL	112 105		186.61	2	Fsp	0.0	7.000	120	56.501 6.032		** Fixed Loss = 3	Vel = 17.84
TOR to BKFL	112 105		186.61	2.067			7.000	0.2979	2.085			Vel = 17.84

# Final Calculations : Hazen-Williams

SUMMIT FIRE SECURITY  
FAIRWAY POINT BLDG 13

Page 7  
Date 9/8/23

Node1 to Node2	Elev1 Elev2	K Fact	Qa Qt	Nom Act	Fitting or Equiv Len	Pipe Ftngs Total	CFact Pf/Ft	Pt Pe Pf	*****	Notes	*****
BKFL to BASE	105 101		0.0 186.61	2 2.067	E 5.0	4.000 5.000 9.000	120 0.2980	64.618 15.732 2.682		** Fixed Loss = 14 Vel = 17.84	
BASE			0.0 186.61					83.032		K Factor = 20.48	
BASE to UG1	101 101		186.61 186.61	2 1.985	E 6.204	5.000 6.203 11.203	150 0.2402	83.032 0.0 2.691		Vel = 19.35	
UG1 to UG2	101 97.500		0.0 186.61	2 1.985	E G 6.204 1.241	10.000 7.444 17.444	150 0.2401	85.723 1.516 4.189		Vel = 19.35	
UG2 to UG3	97.500 110		0.0 186.61	4 4.23	E 2T G 19.223 76.893 3.845 20.184	150.000 120.145 270.145	150 0.0060	91.428 -5.414 1.630		Vel = 4.26	
UG3 to UGT	110 110		-29.70 156.91	8 8.27	G T 6.326 55.354	30.000 61.680 91.680	140 0.0002	87.644 0.0 0.017		Vel = 0.94	
UGT			0.0 156.91					87.661		K Factor = 16.76	
UG3 to UG4	110 110		29.70 29.7	8 8.27	4F 56.936	750.000 56.936 806.936	140 0	87.644 0.0 0.007		Vel = 0.18	
UG4 to UG5	110 110		0.0 29.7	8 8.27	F 2T 14.234 110.709	500.000 124.943 624.943	140 0	87.651 0.0 0.005		Vel = 0.18	
UG5 to UGT	110 110		0.0 29.7	8 8.27	G T 6.326 55.354	500.000 61.680 561.680	140 0	87.656 0.0 0.005		Vel = 0.18	
UGT to TEST	110 110		156.91 186.61	8 8.27	G T 6.326 55.354	10.000 61.680 71.680	140 0.0003	87.661 0.0 0.019		Vel = 1.11	
TEST			250.00 436.61					87.680		Qa = 250.00 K Factor = 46.63	



## Hydraulic Calculations by HydraCALC

SUMMIT FIRE SECURITY  
1609 HERITAGE COMMERCE CT  
WAKE FOREST NC 27587  
919-872-3250

Job Name : FAIRWAY POINTE BLDG 13  
Drawing : FP4  
Location : 200 GALLERY DR SPRING LAKE NC 28390  
Remote Area : RA2  
Contract : 1-5046-00326  
Data File : RA2 BLDG 2 UNIT.WXF

---

**HYDRAULIC CALCULATIONS**  
**for**

**JOB NAME** FAIRWAY POINTE BLDG 13  
**Location** 200 GALLERY DR SPRING LAKE NC 28390  
**Drawing #** FP4  
**Contract #** 1-5046-00326  
**Date** 9/8/23

**DESIGN**

**Remote area #** RA2  
**Remote area location** BLDG 13 LEVEL 3 LIVING ROOM - UNIT 301  
**Occupancy classification** 13R  
**Density** 0.05 - Gpm/SqFt  
**Area of application** ENTIRE - SqFt  
**Coverage/sprinkler** VARIES - SqFt  
**Type of sprinkler calculated** RES. PEND  
**# Sprinklers calculated** 3  
**In-rack demand** - GPM  
**Hose streams** - GPM  
**Total water required (including hose streams)** 66.9868 - GPM @ 82.0069 - Psi  
**Type of system** WET  
**Volume of system (dry or pre-action)** - Gal

**WATER SUPPLY INFORMATION**

**Test date** 4/5/23  
**Location** GALLERY DR  
**Source of info** SUMMIT FIRE & SECURITY

**CONTRACTOR INFO** SUMMIT FIRE SECURITY  
**Address** 1609 HERITAGE COMMERCE CT WAKE FOREST NC  
**Phone #** 919-872-3250  
**Name of designer** I. BURROWS  
**Authority having jurisdiction** HARNETT COUNTY  
**NOTES:**

text1(35) - invisible

# Water Supply Curve

SUMMIT FIRE SECURITY  
FAIRWAY POINTE BLDG 13

Page 2  
Date 9/8/23

City Water Supply:  
C1 - Static Pressure : 119  
C2 - Residual Pressure: 110  
C2 - Residual Flow : 522

Demand:  
D1 - Elevation : 9.095  
D2 - System Flow : 66.987  
D2 - System Pressure : 82.007  
Hose ( Demand ) : \_\_\_\_\_  
D3 - System Demand : 66.987  
Safety Margin : 36.792

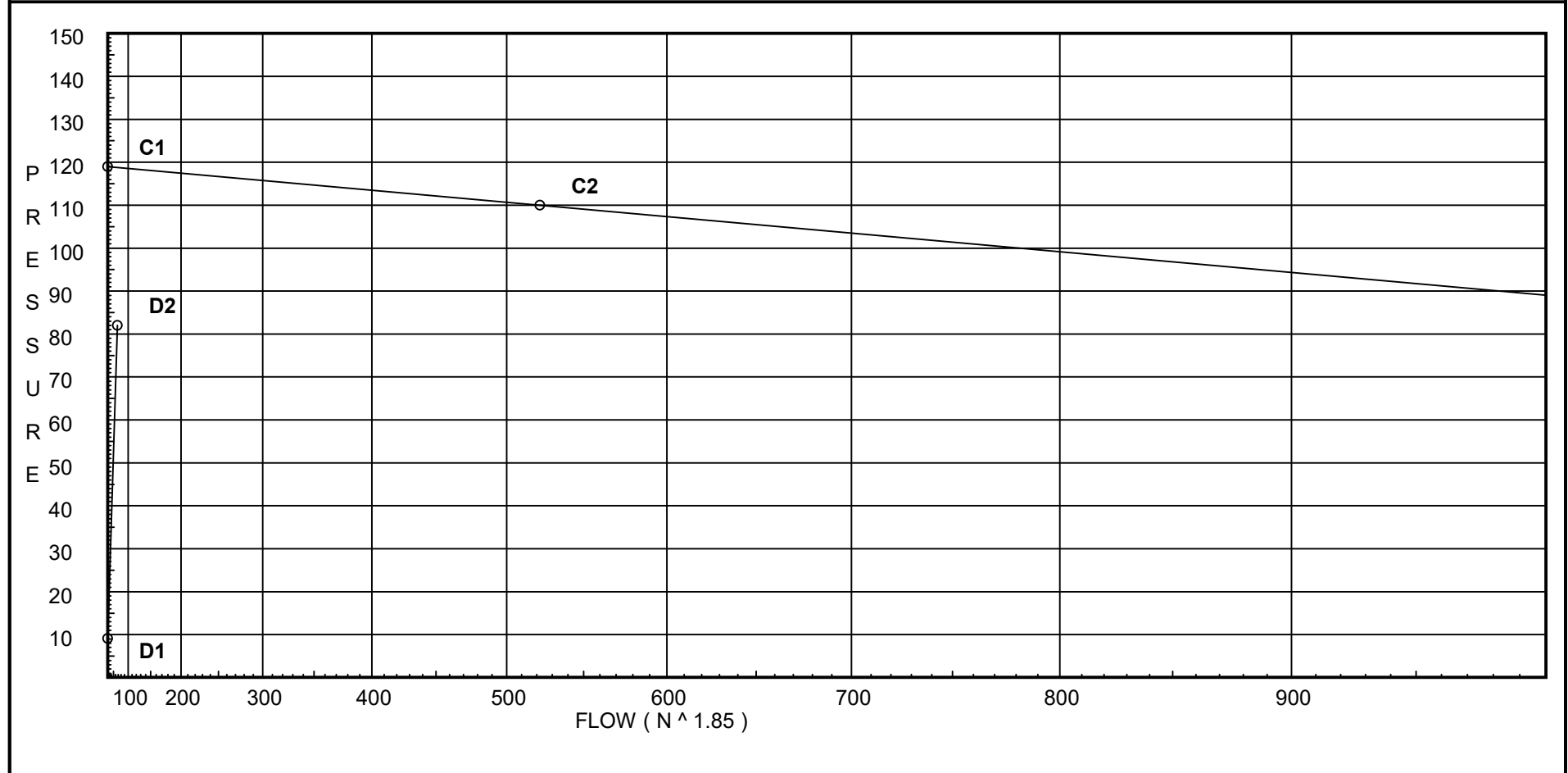

# Fittings Used Summary

SUMMIT FIRE SECURITY  
FAIRWAY POINTE BLDG 13

Page 3  
Date 9/8/23

## Fitting Legend

Abbrev.	Name	1/2	3/4	1	1 1/4	1 1/2	2	2 1/2	3	3 1/2	4	5	6	8	10	12	14	16	18	20	24
E	NFPA 13 90' Standard Elbow	1	2	2	3	4	5	6	7	8	10	12	14	18	22	27	35	40	45	50	61
F	NFPA 13 45' Elbow	1	1	1	1	2	2	3	3	3	4	5	7	9	11	13	17	19	21	24	28
Fsp	Flow Switch Potter VSR	Fitting generates a Fixed Loss Based on Flow																			
G	NFPA 13 Gate Valve	0	0	0	0	0	1	1	1	1	2	2	3	4	5	6	7	8	10	11	13
H	45' Grvd-Vic Elbow #11	0	0	1	1.5	2	2	3	3	3.5	3.5	4.5	5	6.5	8.5	10	18	20	23	25	30
N *	CPVC 90' Ell	0	4	5	6	7	9	12	13	0	0	0	0	0	0	0	0	0	0	0	0
O *	CPVC Branch Tee	0	3	5	6	8	10	12	15	0	0	0	0	0	0	0	0	0	0	0	0
T	NFPA 13 90' Flow thru Tee	3	4	5	6	8	10	12	15	17	20	25	30	35	50	60	71	81	91	101	121

## Units Summary

Diameter Units                   Inches  
 Length Units                     Feet  
 Flow Units                        US Gallons per Minute  
 Pressure Units                   Pounds per Square Inch

Note: Fitting Legend provides equivalent pipe lengths for fittings types of various diameters. Equivalent lengths shown are standard for actual diameters of Sched 40 pipe and CFactors of 120 except as noted with \*. The fittings marked with a \* show equivalent lengths values supplied by manufacturers based on specific pipe diameters and CFactors and they require no adjustment. All values for fittings not marked with a \* will be adjusted in the calculation for CFactors of other than 120 and diameters other than Sched 40 per NFPA.

**SUPPLY ANALYSIS**

<b>Node at Source</b>	<b>Static Pressure</b>	<b>Residual Pressure</b>	<b>Flow</b>	<b>Available Pressure</b>	<b>Total Demand</b>	<b>Required Pressure</b>
TEST	119.0	110	522.0	118.798	66.99	82.007

**NODE ANALYSIS**

<b>Node Tag</b>	<b>Elevation</b>	<b>Node Type</b>	<b>Pressure at Node</b>	<b>Discharge at Node</b>	<b>Notes</b>	
S201	131.0	4.2	28.2	22.3	0.05	256
S202	131.0	4.2	27.4	21.98	0.05	320
S203	131.0	4.2	29.21	22.7	0.05	256
201	120.0		36.8			
202	120.0		35.91			
203	120.0		37.95			
M1	120.0		38.62			
M2	120.0		39.23			
X	120.0		46.78			
M3	120.0		38.85			
C	112.0		57.25			
TOR	112.0		62.14			
BKFL	105.0		68.49			
BASE	101.0		84.62			
UG1	101.0		85.02			
UG2	97.5		87.17			
UG3	110.0		82.0			
UG4	110.0		82.0			
UG5	110.0		82.0			
UGT	110.0		82.0			
TEST	110.0		82.01			



# Final Calculations : Hazen-Williams

SUMMIT FIRE SECURITY  
FAIRWAY POINTE BLDG 13

Page 5  
Date 9/8/23

Node1 to Node2	Elev1 Elev2	K Fact	Qa Qt	Nom Act	Fitting or Equiv	Len	Pipe Ftngs Total	CFact Pf/Ft	Pt Pe Pf	*****	Notes	*****
S201 to 201	131 120	4.20	22.30 22.3	0.75 0.874	N	4.0	11.000 4.000 15.000	150 0.2563	28.195 4.764 3.844		Vel = 11.93	
201			0.0 22.30						36.803		K Factor = 3.68	
S202 to 202	131 120	4.20	21.98 21.98	0.75 0.874	N	4.0	11.000 4.000 15.000	150 0.2495	27.400 4.764 3.743		Vel = 11.75	
202			0.0 21.98						35.907		K Factor = 3.67	
S203 to 203	131 120	4.20	22.70 22.7	0.75 0.874	N	4.0	11.000 4.000 15.000	150 0.2648	29.212 4.764 3.972		Vel = 12.14	
203			0.0 22.70						37.948		K Factor = 3.68	
201 to M1	120 120		22.30 22.3	0.75 0.874	2O	6.0	1.083 6.000 7.083	150 0.2562	36.803 0.0 1.815		Vel = 11.93	
M1			0.0 22.30						38.618		K Factor = 3.59	
202 to M2	120 120		21.98 21.98	0.75 0.874	O N	3.0 4.0	6.333 7.000 13.333	150 0.2495	35.907 0.0 3.327		Vel = 11.75	
M2			0.0 21.98						39.234		K Factor = 3.51	
203 to M3	120 120		22.70 22.7	0.75 0.874	O	3.0	0.417 3.000 3.417	150 0.2646	37.948 0.0 0.904		Vel = 12.14	
M3			0.0 22.70						38.852		K Factor = 3.64	
M1 to M2	120 120		9.55 9.55	1 1.101	N	5.0	30.583 5.000 35.583	150 0.0173	38.618 0.0 0.616		Vel = 3.22	
M2 to X	120 120		21.98 31.53	1 1.101	N	5.0	42.791 5.000 47.791	150 0.1580	39.234 0.0 7.549		Vel = 10.63	
X to M3	120 120		-66.99 -35.46	1 1.101	N	5.0	35.417 5.000 40.417	150 -0.1962	46.783 0.0 -7.931		Vel = 11.95	
M3 to M1	120 120		22.71 -12.75	1 1.101	N	5.0	2.917 5.000 7.917	150 -0.0296	38.852 0.0 -0.234		Vel = 4.30	
M1			0.0 -12.75						38.618		K Factor = -2.05	
X to C	120 112		66.99 66.99	1 1.101			11.000 11.000	150 0.6367	46.783 3.465 7.004		Vel = 22.57	

# Final Calculations : Hazen-Williams

SUMMIT FIRE SECURITY  
FAIRWAY POINTE BLDG 13

Page 6  
Date 9/8/23

Node1 to Node2	Elev1 Elev2	K Fact	Qa Qt	Nom Act	Fitting or Eqiv Len	Pipe Ftngs Total	CFact Pf/Ft	Pt Pe Pf	*****	Notes	*****
C to TOR	112 112		0.0 66.99	2 2.003	4N O 36.0 10.0	95.541 46.000 141.541	150 0.0345	57.252 0.0 4.888			Vel = 6.82
TOR			0.0 66.99					62.140			K Factor = 8.50
TOR to BKFL	112 105		66.99	2 2.067	Fsp 0.0	7.000 7.000	120 0.0447	62.140 6.032 0.313			** Fixed Loss = 3 Vel = 6.40
BKFL to BASE	105 101		0.0 66.99	2 2.067	E 5.0	4.000 5.000 9.000	120 0.0449	68.485 15.732 0.404			** Fixed Loss = 14 Vel = 6.40
BASE			0.0 66.99					84.621			K Factor = 7.28
BASE to UG1	101 101		66.99	2 1.985	E 6.204	5.000 6.203 11.203	150 0.0361	84.621 0.0 0.404			Vel = 6.95
UG1 to UG2	101 97.500		0.0 66.99	2 1.985	E G 6.204 1.241	10.000 7.444 17.444	150 0.0361	85.025 1.516 0.629			Vel = 6.95
UG2 to UG3	97.500 110		0.0 66.99	4 4.23	E 2T G 19.223 76.893 3.845 20.184	150.000 120.145 270.145	150 0.0009	87.170 -5.414 0.245			Vel = 1.53
UG3 to UGT	110 110		-10.66 56.33	8 8.27	G T 6.326 55.354	30.000 61.680 91.680	140 0	82.001 0.0 0.003			Vel = 0.34
UGT			0.0 56.33					82.004			K Factor = 6.22
UG3 to UG4	110 110		10.66	8 8.27	4F 56.936	750.000 56.936 806.936	140 0	82.001 0.0 0.001			Vel = 0.06
UG4 to UG5	110 110		0.0 10.66	8 8.27	F 2T 14.234 110.709	500.000 124.943 624.943	140 0	82.002 0.0 0.001			Vel = 0.06
UG5 to UGT	110 110		0.0 10.66	8 8.27	G T 6.326 55.354	500.000 61.680 561.680	140 0	82.003 0.0 0.001			Vel = 0.06
UGT to TEST	110 110		56.33 66.99	8 8.27	G T 6.326 55.354	10.000 61.680 71.680	140 0	82.004 0.0 0.003			Vel = 0.40
TEST			0.0 66.99					82.007			K Factor = 7.40