

ALL NOTES APPLY TO ALL DRAWINGS UNLESS NOTED OTHERWISE. THE CONTRACTOR SHALL BE RESPONSIBLE FOR THE PROTECTION OF ALL UTILITIES AND SHALL BE RESPONSIBLE FOR THE PROTECTION OF ALL EXISTING AND REMAINING UTILITIES. THE CONTRACTOR SHALL BE RESPONSIBLE FOR THE PROTECTION OF ALL EXISTING AND REMAINING UTILITIES. THE CONTRACTOR SHALL BE RESPONSIBLE FOR THE PROTECTION OF ALL EXISTING AND REMAINING UTILITIES.

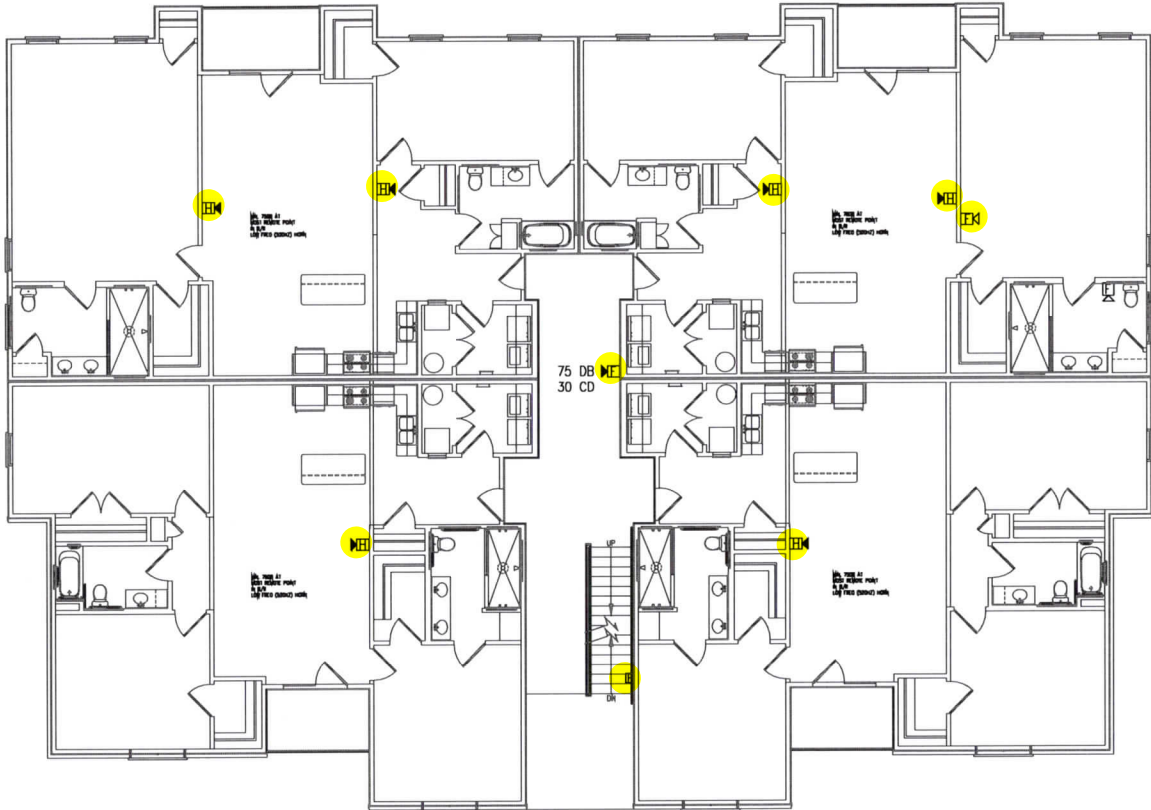

FIRE ALARM LEGEND

- FA2** FIRE ALARM CONTROL UNIT
- F** PULL STATION
- FS** FLOW SWITCH
- TS** TAMPER SWITCH
- H** HORN STROBE
- HO** HORN ONLY
- ST** STROBE ONLY

1
FA2 FIRE ALARM PLAN-2ND FLOOR
3/16"=1'-0"

Coastal Plains Engineering, P.A.

600 LAKELAND BL
750 S. BAY ST
PRAIRIEVILLE, NC 28382
Phone: 910-961-7812
Fax: 910-961-7813
www.cpe-engineering.com

License No: C-2888

Apr 27, 2021

PRINTING STAMP:

FA2
SHEET OF



ANDREW H. PRIVETTE, AA
1920 FT. BRAGG ROAD
FARETTVILLE,
NORTH CAROLINA 28303
TELE. (910) 486-8667
andy@designtobuild.com

FAIRWAY POINTE at ANDERSON CREEK CLUB
THREE-STORY, TEN-UNIT BUILDING
GALLERY DRIVE, BUILDING
SPRING LAKE, NORTH CAROLINA 28390

No.	Date	Description

JOB CODE: 2021-078
DRAWN BY: AA
CHECKED BY: CB
COPYRIGHT: DESIGNED TO BUILD

SHEET TITLE:
FIRE ALARM PLAN
SECOND FLOOR

EACH CONTRACTOR IS REQUIRED TO INCLUDE ALL MINOR ITEMS, WHETHER OR NOT SHOWN ON PLANS, AS REQUIRED BY CODE AND FOR WORKING SYSTEMS, IN INITIAL COST OF WORK, AND AT NO ADDITIONAL COST TO THE OWNER. ANY DEVIATIONS FROM THESE DRAWINGS AND SPECIFICATIONS BY THE OWNER OR CONTRACTOR MUST BE APPROVED BY THE ARCHITECT IN WRITING AND PRIOR TO CONSTRUCTION. COPYRIGHT © ALL RIGHTS RESERVED BY DESIGNED TO BUILD. NOT TO BE COPIED OR REPRODUCED WITHOUT WRITTEN PERMISSION.

NFPA 72 AND ADA DEVICE INSTALLATION REQUIREMENTS

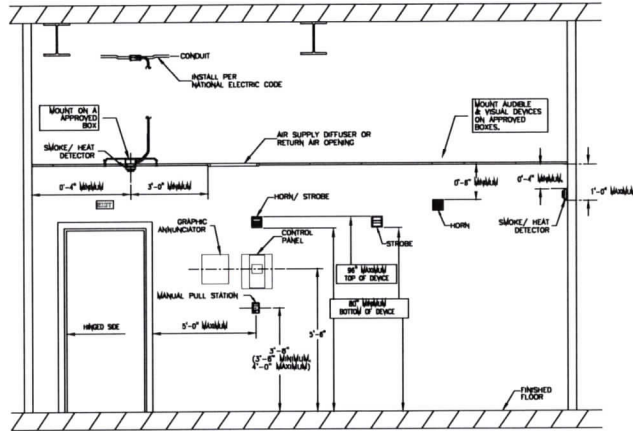

1 FIRE ALARM DEVICE MOUNTING HEIGHTS
FA4 N.T.S.

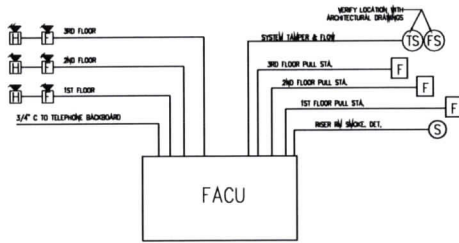

2 FIRE ALARM RISER DIAGRAM
FA4 N.T.S.

SYSTEM INPUTS	SYSTEM OUTPUTS																			
	FACP INDICATIONS					NOTIFICATION														
	A	B	C	E	F	H	I	J	K	L	M	N	O	P	Q	R	S	T	U	V
1 FIRE ALARM SYSTEM AC POWER FAILURE																				
2 FIRE ALARM SYSTEM LOW BATTERY																				
3 OPEN CIRCUIT																				
4 GROUND FAULT																				
5 NOTIFICATION APPLIANCE CIRCUIT SHORT																				
6 FREEZEWAY MANUAL PULL STATIONS																				
7 SMOKE DETECTOR AT FACP																				
8 SPRINKLER TAMPER SWITCH																				
9 SPRINKLER WATER FLOW IN BUILDING																				
10 -																				
11 -																				

ALL NOTES APPLY TO ALL ORDERS AND ALL SIZES. IT IS THE RESPONSIBILITY OF THE CONTRACTOR AND OWNER TO VERIFY THE INSTALLATION OF THIS SYSTEM WITH THE INSTALLATION OF ANY OTHER CONDUCTIVE AND/OR NON-CONDUCTIVE DEVICES. FOLLOW MANUFACTURER'S INSTALLATION INSTRUCTIONS. THE RESPONSIBILITY OF THE CONTRACTOR IS TO VERIFY THE INSTALLATION OF THIS SYSTEM WITH THE INSTALLATION OF ANY OTHER CONDUCTIVE AND/OR NON-CONDUCTIVE DEVICES. FOLLOW MANUFACTURER'S INSTALLATION INSTRUCTIONS. THE RESPONSIBILITY OF THE CONTRACTOR IS TO VERIFY THE INSTALLATION OF THIS SYSTEM WITH THE INSTALLATION OF ANY OTHER CONDUCTIVE AND/OR NON-CONDUCTIVE DEVICES. FOLLOW MANUFACTURER'S INSTALLATION INSTRUCTIONS.



ANDREW W. PRIVETTE, AIA
1920 FT. BRAGG ROAD
FARETTVILLE,
NORTH CAROLINA 28303
TELE. (910) 486-8567
andy@designedtobuild.com

FAIRWAY POINTE at ANDERSON CREEK CLUB
THREE-STORY, TEN-UNIT BUILDING
GALLERY DRIVE, BUILDING
SPRING LAKE, NORTH CAROLINA 28390

Coastal Plains Engineering, P.A.
505 LAKESHORE DR
P.O. Box 1113
Pawleys, NC 28372
Phone: 813-981-7511
Fax: 813-981-7513
www.coastalplainseng.com



Apr 27, 2021
PRINTING STAMP:

JOB CODE: 2021-018
DRAWN BY: M.A.
CHECKED BY: C.R.
COPYRIGHT:
DESIGNED TO BUILD

SHEET TITLE:
FIRE ALARM DETAILS

FA4
SHEET OF

EACH CONTRACTOR IS REQUIRED TO INCLUDE ALL MINOR ITEMS, WHETHER OR NOT SHOWN ON PLANS, AS REQUIRED BY CODE AND FOR WORKING SYSTEMS, IN INITIAL COST OF WORK, AND AT NO ADDITIONAL COST TO THE OWNER. ANY DEVIATIONS FROM THESE DRAWINGS AND SPECIFICATIONS BY THE OWNER OR CONTRACTOR MUST BE APPROVED BY THE ARCHITECT IN WRITING AND PRIOR TO CONSTRUCTION. COPYRIGHT © ALL RIGHTS RESERVED BY DESIGNED TO BUILD. NOT TO BE COPIED OR REPRODUCED WITHOUT WRITTEN PERMISSION.



Application for Plan Review

Application # _____ - _____

Date Received: _____ Received By: _____

Name of Project: FAIRWAY POINTE AT ANDERSON CREEK CLUB

Physical Address of Project: GALLERY DRIVE BUILDING #4

SPRING LAKE, NC 28390

Plans Submitted By: HOLMES SECURITY SYSTEMS

Project Phone: (910)- 483-1196

Contact Person/Address: AMANDA DOMINA
407 RAY AVE
FAYETTEVILLE, NC 28301

Contact Email: ADOMINA@HOLMESELECTRICSECURITY.COM

Contact Phone: (910)- 483-1196 (910)- 635-6924

Contractor's Name/Info: HOLMES SECURITY SYSTEMS
407 RAY AVE
FAYETTEVILLE, NC 28301

Contractor's Phone: (910)- 483-1196

- Plans that are submitted will be reviewed as quickly as possible with an average time of review between 7-10 working days.
- Status checks may be conducted on plan reviews by visiting the website <http://hteweb.harnett.org/Click2GovBP/Index.jsp> or by calling the Harnett County Central Permitting Office (910-893-7525, Option #2), or the Harnett County Fire Marshal's Office (910-893-7580).
- Approved plans must be picked up from the Central Permitting Office and all fees paid before any required inspections can be conducted.

MMF-300(A) Series, MDF-300(A)

Addressable Monitor Modules



Addressable Devices

General

Four different monitor modules are available for Fire•Lite's intelligent control panels to suit a variety of applications. Monitor modules are used to supervise a circuit of dry-contact input devices, such as conventional heat detectors and pull stations, or monitor and power a circuit of two-wire smoke detectors (MMF-302(A)).

MMF-300(A) is a standard-sized module (typically mounts to a 4" [10.16 cm] square box) that supervises either a Style D (Class A) or Style B (Class B) circuit of dry-contact input devices.

MMF-301(A) is a miniature monitor module a mere 1.3" (3.302 cm) H x 2.75" (6.985 cm) W x 0.5" (1.270 cm) D used to supervise a Style B (Class B) circuit of dry-contact input devices. Its compact design allows the MMF-301(A) to be mounted in a single-gang box behind the device it monitors.

MMF-302(A) is a standard-sized module used to monitor and supervise compatible two-wire, 24 volt, smoke detectors on a Style D (Class A) or Style B (Class B) circuit.

MDF-300(A) is a standard-sized dual monitor module used to monitor and supervise two independent two-wire Style B (Class B) dry-contact initiating device circuits (IDCs) at two separate, consecutive addresses in intelligent, two-wire systems.

LiteSpeed™ is a communication protocol developed by Fire•Lite Engineering that greatly enhances the speed of communication between analog intelligent devices. Intelligent devices communicate in a grouped fashion. If one of the devices within the group has new information, the panel CPU stops the group poll and concentrates on single points. The net effect is response speed greater than five times that of other designs.

MMF-300(A) Monitor Module

- Built-in type identification automatically identifies this device as a monitor module to the control panel.
- Powered directly by two-wire SLC loop. No additional power required.
- High noise (EMF/RFI) immunity.
- SEMS screws with clamping plates for ease of wiring.
- Direct-dial entry of address: 01 – 159 on MS-9600 series panels, 01 – 99 on other compatible systems.
- LED flashes during normal operation and latches on steady to indicate alarm.

The MMF-300(A) Monitor Module is intended for use in intelligent, two-wire systems, where the individual address of each module is selected using the built-in rotary switches. It provides either a two-wire or four-wire fault-tolerant Initiating Device Circuit (IDC) for normally-open-contact fire alarm and supervisory devices. The module has a panel-controlled LED indicator. The MMF-300(A) can be used to replace M300(A) modules in existing systems.

MMF-300(A) APPLICATIONS

Use to monitor a zone of four-wire smoke detectors, manual fire alarm pull stations, waterflow devices, or other normally-open dry-contact alarm activation devices. May also be used to monitor normally-open supervisory devices with special supervisory indication at the control panel. Monitored circuit

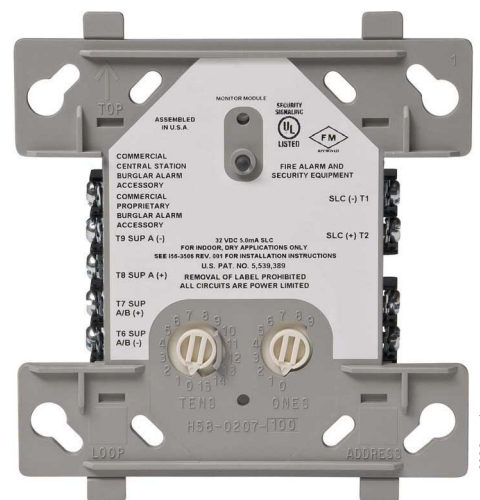

MMF-300(A) (Type H)

may be wired as an NFPA Style B (Class B) or Style D (Class A) Initiating Device Circuit. A 47K ohm End-of-Line Resistor (provided) terminates the Style B circuit. No resistor is required for supervision of the Style D circuit.

MMF-300(A) OPERATION

Each MMF-300(A) uses one of the available module addresses on an SLC loop. It responds to regular polls from the control panel and reports its type and the status (open/normal/short) of its Initiating Device Circuit (IDC). A flashing LED indicates that the module is in communication with the control panel. The LED latches steady on alarm (subject to current limitations on the loop).

MMF-300(A) SPECIFICATIONS

Nominal operating voltage: 15 to 32 VDC.

Maximum current draw: 5.0 mA (LED on).

Average operating current: 350 µA (LED flashing), 1 communication every 5 seconds, 47k EOL.

Maximum IDC wiring resistance: 40 ohms.

EOL resistance: 47K ohms.

Temperature range: 32°F to 120°F (0°C to 49°C).

Humidity range: 10% to 93% noncondensing.

Dimensions: 4.5" (11.43 cm) high x 4" (10.16 cm) wide x 1.25" (3.175 cm) deep. Mounts to a 4" (10.16 cm) square x 2.125" (5.398 cm) deep box.

MMF-301(A) Mini Monitor Module

- Built-in type identification automatically identifies this device as a monitor module to the panel.
- Powered directly by two-wire SLC loop. No additional power required.
- High noise (EMF/RFI) immunity.
- Tinned, stripped leads for ease of wiring.
- Direct-dial entry of address: 01 – 159 on MS-9600 series panels, 01 – 99 on other compatible systems

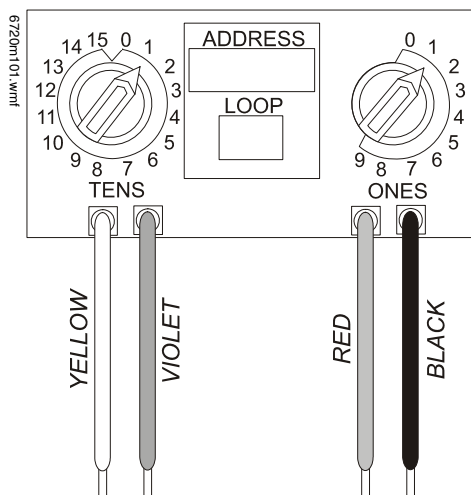

The MMF-301(A) Mini Monitor Module can be installed in a single-gang junction directly behind the monitored unit. Its small size and light weight allow it to be installed without rigid mounting. The MMF-301(A) is intended for use in intelligent, two-wire systems where the individual address of each module is selected using rotary switches. It provides a two-wire initiating device circuit for normally-open-contact fire alarm devices. The MMF-301(A) can be used to replace M301(A) modules in existing systems.

MMF-301(A) APPLICATIONS

Use to monitor a single device or a zone of four-wire smoke detectors, manual fire alarm pull stations, waterflow devices, or other normally-open dry-contact devices. May also be used to monitor normally-open supervisory devices with special supervisory indication at the control panel. Monitored circuit/device is wired as an NFPA Style B (Class B) Initiating Device Circuit. A 47K ohm End-of-Line Resistor (provided) terminates the circuit.

MMF-301(A) OPERATION

Each MMF-301(A) uses one of the available module addresses on an SLC loop. It responds to regular polls from the control panel and reports its type and the status (open/normal/short) of its Initiating Device Circuit (IDC).

MMF-301(A) SPECIFICATIONS

Nominal operating voltage: 15 to 32 VDC.

Average operating current: 350 μ A, 1 communication every 5 seconds, 47k EOL; 600 μ A Max. (Communicating, IDC Shorted).

Maximum IDC wiring resistance: 40 ohms.

Maximum IDC Voltage: 11 Volts.

Maximum IDC Current: 400 μ A.

EOL resistance: 47K ohms.

Temperature range: 32°F to 120°F (0°C to 49°C).

Humidity range: 10% to 93% noncondensing.

Dimensions: 1.3" (3.302 cm) high x 2.75" (6.985 cm) wide x 0.65" (1.651 cm) deep.

Wire length: 6" (15.24 cm) minimum.

MMF-302(A) Interface Module

- Supports compatible two-wire smoke detectors.
- Supervises IDC wiring and connection of external power source.
- High noise (EMF/RFI) immunity.
- SEMS screws with clamping plates for ease of wiring.
- Direct-dial entry of address: 01 – 159 on MS-9600 series panels, 01 – 99 on other compatible systems.
- LED flashes during normal operation.
- LED latches steady to indicate alarm on command from control panel.

The MMF-302(A) Interface Module is intended for use in intelligent, addressable systems, where the individual address of each module is selected using built-in rotary switches. This module allows intelligent panels to interface and monitor two-wire conventional smoke detectors. It transmits the status (normal, open, or alarm) of one full zone of conventional detectors back to the control panel. All two-wire detectors being monitored must be UL compatible with the module. The MMF-302(A) can be used to replace M302(A) modules in existing systems.

MMF-302 (A) APPLICATIONS

Use the MMF-302(A) to monitor a zone of two-wire smoke detectors. The monitored circuit may be wired as an NFPA Style B (Class B) or Style D (Class A) Initiating Device Circuit. A 3.9 K ohm End-of-Line Resistor (provided) terminates the end of the Style B or D (class B or A) circuit (maximum IDC loop resistance is 25 ohms). Install ELR across terminals 8 and 9 for Style D application.

MMF-302(A) OPERATION

Each MMF-302(A) uses one of the available module addresses on an SLC loop. It responds to regular polls from the control panel and reports its type and the status (open/normal/short) of its Initiating Device Circuit (IDC). A flashing LED indicates that the module is in communication with the control panel. The LED latches steady on alarm (subject to current limitations on the loop).

MMF-302(A) SPECIFICATIONS

Nominal operating voltage: 15 to 32 VDC.

Maximum current draw: 5.1 mA (LED on).

Maximum IDC wiring resistance: 25 ohms.

Average operating current: 300 μ A, 1 communication and 1 LED flash every 5 seconds, 3.9k eol.

EOL resistance: 3.9K ohms.

External supply voltage (between Terminals T3 and T4): DC voltage: 24 volts power limited. Ripple voltage: 0.1 Vrms maximum. Current: 90 mA per module maximum.

Temperature range: 32°F to 120°F (0°C to 49°C).

Humidity range: 10% to 93% noncondensing.

Dimensions: 4.5" (11.43 cm) high x 4" (10.16 cm) wide x 1.25" (3.175 cm) deep. Mounts to a 4" (10.16 cm) square x 2.125" (5.398 cm) deep box.

MDF-300(A) Dual Monitor Module

The MDF-300(A) Dual Monitor Module is intended for use in intelligent, two-wire systems. It provides two independent two-wire initiating device circuits (IDCs) at two separate, consecutive addresses. It is capable of monitoring normally open contact fire alarm and supervisory devices. The module has a single panel-controlled LED.

NOTE: The MDF-300(A) provides two Style B (Class B) IDC circuits ONLY. Style D (Class A) IDC circuits are NOT supported in any application.

MDF-300(A) SPECIFICATIONS

Normal operating voltage range: 15 to 32 VDC.

Maximum current draw: 6.4 mA (LED on).

Average operating current: 750 μ A (LED flashing).

Maximum IDC wiring resistance: 1,500 ohms.

Maximum IDC Voltage: 11 Volts.

Maximum IDC Current: 240 μ A

EOL resistance: 47K ohms.

Maximum SLC Wiring resistance: 40 Ohms.

Temperature range: 32° to 120°F (0° to 49°C).

Humidity range: 10% to 93% (non-condensing).

Dimensions: 4.5" (11.43 cm) high x 4" (10.16 cm) wide x 2.125" (5.398 cm) deep.

MDF-300(A) AUTOMATIC ADDRESSING

The MDF-300(A) automatically assigns itself to two addressable points, starting with the original address. For example, if the MDF-300(A) is set to address "26", then it will automatically assign itself to addresses "26" and "27".

NOTE: "Ones" addresses on the MDF-300(A) are 0, 2, 4, 6, or 8 only. Terminals 6 and 7 use the first address, and terminals 8 and 9 use the second address.



CAUTION:

Avoid duplicating addresses on the system.

Installation

MMF-300(A), MMF-302(A), and MDF-300(A) modules mount directly to a standard 4" (10.16 cm) square, 2.125" (5.398 cm) deep, electrical box. They may also be mounted to the SMB500 surface-mount box. Mounting hardware and installation instructions are provided with each module. All wiring must conform to applicable local codes, ordinances, and regulations. These modules are intended for power-limited wiring only.

The MMF-301(A) module is intended to be wired and mounted without rigid connections inside a standard electrical box. All wiring must conform to applicable local codes, ordinances, and regulations.

Agency Listings and Approvals

In some cases, certain modules may not be listed by certain approval agencies, or listing may be in process. Consult factory for latest listing status.

- **UL:** S2424
- **ULC:** S2424
- **FM Approved**
- **CSFM:** 7300-0075:0185
- **MEA:** 72-01-E

Product Line Information

NOTE: "A" suffix indicates ULC-listed model.

MMF-300(A): Monitor module.

MMF-301(A): Monitor module, miniature.

MMF-302(A): Monitor module, two-wire detectors.

MDF-300(A): Monitor module, dual, two independent Class B circuits.

SMB500: Optional surface-mount backbox.

NOTE: See installation instructions and refer to the SLC Wiring Manual, PN 51309.

Architects'/Engineers' Specifications

Specifications of these devices and all FireLite products are available from FireLite.

Fire-Lite® and LiteSpeed® are registered trademarks and FireWatch™ is a trademark of Honeywell International Inc.
©2010 by Honeywell International Inc. All rights reserved. Unauthorized use of this document is strictly prohibited.



This document is not intended to be used for installation purposes.
We try to keep our product information up-to-date and accurate.
We cannot cover all specific applications or anticipate all requirements.
All specifications are subject to change without notice.



Made in the U.S. A.

For more information, contact Fire•Lite Alarms. Phone: (800) 627-3473, FAX: (877) 699-4105.
www.firelite.com

- **Universal full event sole & dual path cellular &/or IP commercial fire alarm reporting from any panel brand, virtually anywhere nationwide**
- **Code-compliant, replaces 2 POTs lines per FACP** saves thousands of dollars per year over the leased landlines
- **Supports 12V-24V control panels and FACPs** that communicate using Contact ID and 4/2 (such as on legacy panels), as primary or backup
- **Full data Reporting to any Central Station nationwide, via choice of LTE Networks, Verizon® or AT&T®. Communicate critical life and safety alarm reports on LTE (Long Term Evolution) 10+ year life, cyber-protected multi-billion dollar cellular network,** for maximum life safety & liability protection.
- **Proven to work even where other's won't - using Signal Boost™ & twin dual diversity antennas** - Max. signal acquisition & null avoidance (receives signals simultaneously on both antennas)
- **Easiest installation, powered by panel, NO extra power supply, NO extra conduit.** (Excludes Direct AC-Powered "-PS" models, with transformer option.) †
- **Dual Path Cellular/IP Models Save Time & Money** - Uniquely including 4 programmable EOLR zone inputs; 2 Form C Relay outputs (no extra supervision modules to buy or install); plus, 2 Telephone-style jacks for easy FACP-connection. Self-supervised on 4 wires.
- **Preactivated to ensure communications** - saves time and labor onsite
- **LED Status /Trouble Indicators** 3 Radio Status LED Indicators (visible from outside standard model housing) - Green, Signal Strength; Amber- Busy/Activation; Red-Trouble (4 additional LEDs, not visible, for network status & troubleshooting). Power LED indicator viewable on outer metal enclosure models.
- **Over-the-Air Upgradable Communicator Firmware.** Remote ability for critical/mandatory updates, without a truck-roll
- **Cost-saving models and plans for any code requirement.** Dramatic savings over monthly dedicated landline charges.

UL and NFPA 72 Fire Code-Compliant, the StarLink Series Wireless Commercial Fire Alarm Sole Path & Dual Path Communicators provide universal support for any brand 12V to 24V fire alarm control panel, reporting in Contact ID and 4/2. With broadest LTE coverage footprint, Verizon or AT&T, using proven StarLink circuitry, they are also available in locking metal models. All provide the most economical solution for easy, versatile installation. Also regional compliances, i.e., CSFM, NYCFD, LAFD and more.

Easy, Universal Installation at Every Application; Panel-Powered Technology™. StarLink Fire Communications are easily connected to any panel or Fire Alarm Control Panel (FACP) standardly operating between 12V and 24V. Flexible in any application, StarLink Fire also comes in standard, or models in metal housings, with code-compliant supervision, and choice of power options, Panel-Powered Technology™ (powered by the panel), or direct-connect 120VAC models. **Signal Boost circuitry & dual diversity antennae** for maximum signal acquisition & null avoidance, receiving signals simultaneously on both antennae.

Flexible Performance & Reporting Options. StarLink Fire provides full data reporting, in sole and dual path, as a primary or backup, to any central station of your choice, without requiring any special equipment on premises. Ultra-affordable plans are available to meet various codes and requirements, with supervisory check-ins from 200 seconds, to 5 minutes; and/or from 1 to 6 hours. The units are very easily activated, plans and options are selected, and 24/7 account management is provided all through www.napcocomnet.com.

Napco StarLink Universal Fire Alarm Communicators

- **Sole Path Cellular and Dual Path Cellular &/or IP Models**
- **Choice of LTE Networks,** Verizon or AT&T models
- **Choice of plans** (varies by model) - check-ins from 200 seconds to 5-minutes, and from 1 hour; up to 6 hours for dual path
- **Patented Signal Boost™ and Dual Diversity Antennae** for maximum signal acquisition & null avoidance, receiving signals simultaneously on both antennae
- **Money-saving Tradeup incentive credit** for security professionals, on new or retrofit fire systems, i.e., tradeup missing/retired POTs lines, old radios & networks or new installations
- **Bonus: Full High-Speed Napco Panel remote uploading/ downloading**
- **COMPLIANCES:** NFPA 72 Editions: 2019, 2016, 2013, 2010, 2007; UL 864, 10th Ed., UL1610, UL985, UL1023, NYCFD; CSFM; LAFD



Code-compliant standard or metal models on choice of Verizon or AT&T LTE networks.



Model Ordering & Specifications



	LTE Network	Cell	IP	WiFi Option**	Unique Onboard Labor/Cost-Saver Features	Electrical Input Ratings	Inputs	Input Ratings	Outputs	Output Ratings	Other Power Supply (option)†
STANDARD MODELS (ABS) 5.38 x 7.88 x 1.88" (HWD)											
SOLE PATH											
SLE-LTEA-FIRE	AT&T	Yes	No	No		Panel-Powered Tech'y:†† Input Voltage/Input Current: 10V = 90mA; 12-25V = 71mA, 200mA peak during transmissions	IN1, IN2, IN3	IN1: 9-25VDC Max input current 2mA IN2,IN3: 9-25VDC Max input current 1.2mA	PGM1, PGM2, PGM3	Open Collector Outputs Max 3V when active, Max 25V when not active. Max current 24mA@ 25V	
SLE-LTEV-FIRE	Verizon	Yes	No	No							
DUAL PATH											
SLE-LTEAI-FIRE	AT&T	Yes	Yes	Yes	2 TelCo jacks for EZ FACP Connect; 4 Programmable EOLR zone inputs; 2 Form C Relay outputs (avoids reqt for supervision module)	Panel-Powered Tech'y:†† Input Voltage:10-25VDC; Input Current: 162mA to 100mA standby; 300mA peak during transmissions	IN1, IN2, IN3, IN4, IN5	IN1: 9-25VDC Max input current 2mA IN2,IN3,IN4,IN5: 9-25VDC Max input current 1.2mA	OUT1, OUT2, PGM3	OUT1,OUT2: Dry Contact, Form C Relay, 30V AC/DC, 500mA Max PGM3: Open Collector Outputs Max 3V when active, Max 25V when active. Max current 24mA@ 25V	
SLE-LTEVI-FIRE	Verizon	Yes	Yes	Yes							
MODELS IN METAL ENCLOSURE 9.63 x 11.75 x 3.38" (HWD)											
SOLE PATH											
SLE-LTEA-CFB	AT&T	Yes	No	No		Panel-Powered Tech'y:†† Input Voltage/Input Current: 10V = 90mA; 12-25V = 71mA, 200mA peak during transmissions	IN1, IN2, IN3	IN1: 9-25VDC Max input current 2mA IN2,IN3: 9-25VDC Max input current 1.2mA	PGM1, PGM2, PGM3	Open Collector Outputs Max 3V when active, Max 25V when not active. Max current 24mA@ 25V	
SLE-LTEV-CFB	Verizon	Yes	No	No							
SLE-LTEA-CFB-PS	AT&T	Yes	No	No		Direct AC-Powered: Input Voltage: 120VAC nominal Input Current: 150mA max; maximum charging current: 200mA	IN1, IN2, IN3	IN1: 9-25VDC Max input current 2mA IN2,IN3: 9-25VDC Max input current 1.2mA	PGM1, PGM2, PGM3	Open Collector Outputs Max 3V when active, Max 25V when not active. Maximum current 24mA@ 25V	Transformer (TRF12 16VAC, 20VA transformer)
SLE-LTEV-CFB-PS	Verizon	Yes	No	No							
DUAL PATH											
SLE-LTEAI-CFB	AT&T	Yes	Yes	Yes	2 TelCo jacks for EZ FACP Connect; 4 Programmable EOLR zone inputs; 2 Form C Relay outputs (avoids reqt for supervision module)	Panel-Powered Tech'y:†† Input Voltage:10-25VDC; Input Current: 162mA to 100mA standby; 300mA peak during transmissions	IN1, IN2, IN3, IN4, IN5	IN1: 9-25VDC Max input current 2mA IN2,IN3,IN4,IN5: 9-25VDC Max input current 1.2mA	OUT1, OUT2, PGM3	OUT1,OUT2: Dry Contact, Form C Relay, 30V AC/DC, 500mA Max PGM3: Open Collector Outputs Max 3V when active, Max 25V when active. Max current 24mA@ 25V	
SLE-LTEVI-CFB	Verizon	Yes	Yes	Yes							
SLE-LTEAI-CFBPS	AT&T	Yes	Yes	Yes	2 TelCo jacks for EZ FACP Connect; 4 Programmable EOLR zone inputs; 2 Form C Relay outputs (avoids reqt for supervision module)	Direct AC-Powered: Input Voltage: 120VAC nominal Input Current: 200mA max; maximum charging current: 200mA	IN1, IN2, IN3, IN4, IN5	IN1: 9-25VDC Max input current 2mA IN2,IN3,IN4,IN5: 9-25VDC Max input current 1.2mA	OUT1, OUT2, PGM3	OUT1,OUT2: Dry Contact, Form C Relay, 30V AC/DC, 500mA Max PGM3: Open Collector Outputs Max 3V when active, Max 25V when active. Max current 24mA@ 25V	Transformer (TRF12 16VAC, 20VA transformer)
SLE-LTEVI-CFBPS	Verizon	Yes	Yes	Yes							

ACCESSORIES:

SLE-WIFI-MODULE Optionally connects supported dual path models to Internet via WiFi, eliminating Ethernet cable connection. Requires 7AH batt'y. (**See details WI2191)

SLE-ANEXT75 Optional extended range omni. antenna w/ 75' cable, premium low-loss cable & full mounting hardware & ground fault isolation mounting plate

SLE-ANEXT50 As above, with 50' cable

SLE-ANEXT30 As above, with 30' cable

TRF12 Optional Plug in AC Transformer, 16.5V / 20VA (use is subject to local code compliance)†

Free Commercial Fire LTE Tradeup Trifold Brochures / Mailers/Stuffers (A747)



FireLink™ Integrated Fire Alarm Control Panel w/ StarLink Fire LTE Built In



FL-32FACP-LTEV Firewolf 8 Zone 24V Conventional Commercial Fire Alarm Control Panel with onboard StarLink Fire® Sole Path, Verizon LTE Cellular Alarm Communicator and integral menu-driven LCD annunciator, w/ 4amp, 24V power supply. Optionally expandable up to 32 points/zones via commercial addressable, wireless or conventional fire devices (2 onboard NACs providing up to 4A notification power). Locking, metal red enclosure,(surface or flush mount*) removable 16"x17" door w/14.25"x16" base. Houses 16Ah battery backup.



BG-12LX

Addressable Manual Pull Station



Addressable Devices

General

The Fire-Lite BG-12LX is a state-of-the-art, dual-action (i.e., requires two motions to activate the station) pull station that includes an addressable interface (mounted inside) for Fire-Lite's addressable fire alarm control panels (FACPs). Because the BG-12LX is addressable, the control panel can display the exact location of the activated manual station. This leads fire personnel quickly to the location of the alarm.

Features

- Maintenance personnel can open station for inspection and address setting without causing an alarm condition.
- Built-in bicolor LED, which is visible through the handle of the station, flashes in normal operation and latches steady red when in alarm.
- Handle latches in down position and the word "ACTIVATED" appears to clearly indicate the station has been operated.
- Captive screw terminals wire-ready for easy connection to SLC loop (accepts up to 12 AWG/3.25 mm² wire).
- Can be surface mounted (with SB-10 or SB-I/O) or semi-flush mounted. Semi-flush mount to a standard single-gang, double-gang, or 4" (10.16 cm) square electrical box.
- Smooth dual-action design.
- Meets ADAAG controls and operating mechanisms guidelines (Section 4.1.3[13]); meets ADA requirement for 5 lb. maximum activation force.
- Highly visible.
- Attractive shape and textured finish.
- Key reset.
- Includes Braille text on station handle.
- Optional trim ring (BG12TR).
- Meets UL 38, Standard for Manually Actuated Signaling Boxes.

Construction

Shell, door, and handle are molded of durable polycarbonate material with a textured finish.

Specifications

- **Shipping Weight:** 9.6 oz. (272.15 g)
- **Normal operating voltage:** 24 VDC.
- **Maximum SLC loop voltage:** 28.0 VDC.
- **Maximum SLC standby current:** 375 μ A.
- **Maximum SLC alarm current:** 5 mA.
- **Temperature Range:** 32°F to 120°F (0°C to 49°C)
- **Relative Humidity:** 10% to 93% (noncondensing)
- **For use indoors in a dry location**

Installation

The BG-12LX will mount semi-flush into a single-gang, double-gang, or standard 4" (10.16 cm) square electrical outlet box, or will surface mount to the model SB-10 or SB-I/O surface backbox. If the BG-12LX is being semi-flush mounted, then the optional trim ring (BG12TR) may be used. The BG12TR is



FLPullStation.jpg

usually needed for semi-flush mounting with 4" (10.16 cm) or double-gang boxes (not with single-gang boxes).

Operation

Pushing in, then pulling down on the handle causes it to latch in the down/activated position. Once latched, the word "ACTIVATED" (in bright yellow) appears at the top of the handle, while a portion of the handle protrudes from the bottom of the station. To reset the station, simply unlock the station with the key and pull the door open. This action resets the handle; closing the door automatically resets the switch.

Each manual station, on command from the control panel, sends data to the panel representing the state of the manual switch. Two rotary decimal switches allow address settings (1 – 159 with Breakaway Tab removed for MS-9600 Series, 1 – 99 and MS-9200UDLS, 1 – 50 for MS-9050UD).

Architectural/Engineering Specifications

Manual Fire Alarm Stations shall be non-coded, with a key-operated reset lock in order that they may be tested, and so designed that after actual Emergency Operation, they cannot be restored to normal except by use of a key. An operated station shall automatically condition itself so as to be visually detected as activated. Manual stations shall be constructed of red-colored polycarbonate material with clearly visible operating instructions provided on the cover. The word FIRE shall appear on the front of the stations in white letters, 1.00 inches (2.54 cm) or larger. Stations shall be suitable for surface mounting on matching backbox SB-10 or SB-I/O; or semi-flush mounting on a standard single-gang, double-gang, or 4" (10.16 cm) square electrical box, and shall be installed

within the limits defined by the Americans with Disabilities Act (ADA) or per national/local requirements. Manual Stations shall be Underwriters Laboratories listed.

Manual stations shall connect with two wires to one of the control panel SLC loops. The manual station shall, on command from the control panel, send data to the panel representing the state of the manual switch. Manual stations shall provide address setting by use of rotary decimal switches.

Product Line Information

BG-12LX: Dual-action addressable pull station. Includes key locking feature. (Listed for Canadian and non-Canadian applications.)

SB-10: Surface backbox; metal.

SB-I/O: Surface backbox; plastic.

BG12TR: Optional trim ring.

17003: Keys, set of two.

Agency Listings and Approvals

In some cases, certain modules or applications may not be listed by certain approval agencies, or listing may be in process. Consult factory for latest listing status.

- **UL/ULC Listed:** S711 (listed for Canadian and non-Canadian applications).
- **MEA:** 67-02-E.
- **CSFM:** 7150-0075:0184.
- **FM Approved.**

Patented: U.S. Patent No. D428,351; 6,380,846; 6,314,772; 6,632,108.

FireLite® Alarms® is a registered trademark of Honeywell International Inc. ©2012 by Honeywell International Inc. All rights reserved. Unauthorized use of this document is strictly prohibited.



This document is not intended to be used for installation purposes.
We try to keep our product information up-to-date and accurate.
We cannot cover all specific applications or anticipate all requirements.
All specifications are subject to change without notice.



Made in the U.S. A.

For more information, contact Fire•Lite Alarms. Phone: (800) 627-3473, FAX: (877) 699-4105.
www.firelite.com

ES-50X

Intelligent Addressable FACP with Communicator



Addressable Fire Alarm Control Panels

General

The **ES-50X** is the latest intelligent addressable fire alarm control panel (FACP) from Fire•Lite Alarms and is a direct replacement for the MS-9050UD/LS. The ES-50X comes with a pre-installed communicator and supports up to 50 addressable devices in any combination of detectors or modules. With an extensive list of powerful features, the ES-50X programs just like Fire•Lite's other addressable panels, yet fits into applications previously served only by conventional panels.

The pre-installed IPOTS-COM is a dual technology (POTS and IP) communicator. The POTS transmits system status (alarms, troubles, AC loss, etc.) to a Central Station via the public switched telephone network. The IP communicator's internet monitoring capability sends alarm signals over the Internet saving the monthly cost of two dedicated business telephone lines. Although not required, the secondary telephone line may be retained providing backup communication over the public switched telephone line. Optional cellular reporting is available using the CELL-MOD or CELL-CAB-FL.

Remote and local programming of the control panel is possible using the FS-Tools Upload/Download utility. Programming databases can be uploaded/downloaded via the panel's USB port (and USB cable) or via an ethernet connection using the IPOTS-COM communicator. The USB port also allows for the download or upload of the entire program, history file, walk-test data, current status and system voltages by means of a USB flash drive.

The power supply and all electronics are contained on a circuit board supported on a new quick install chassis and housed in a metal cabinet. Available accessories include local and remote upload/download software, remote annunciators, and reverse polarity/city box transmitter (4XTMF).

Features

- Listed to UL Standard 864, 10th edition
- Pre-installed IPOTS-COM Ethernet IP and POTS (Plain Old Telephone Service) Central Station Communicator
- Optional CELL-MOD or CELL-CAB-FL GSM Central Station Communicator over AlarmNet®
- Compatible with SWIFT® wireless devices
- Auto-programming (learn mode) reduces installation time. Reports two devices set to the same address
- Two independently programmable, built-in Style Z (Class A) or Style Y (Class B) NAC circuits
- Selectable strobe synchronization for System Sensor, Wheelock, and Gentex devices
- Notification Appliance Circuit End of Line resistor matching
- Four programmable function keys for ease of maintenance
- Two programmable relays and one fixed trouble relay
- Built-in Programmer
- Integral 80-character LCD display with backlighting
- Real-time clock/calendar with automatic daylight savings control
- History file with 1,000 event capacity
- Addressable sounder base
- Multi-criteria detector (smoke, heat, CO) with programmable response
- Control module delay timer
- Automatic detector sensitivity testing (NFPA 72 compliant)
- Automatic device type-code verification
- Point trouble identification
- Waterflow selection per module point
- Alarm verification selection per detector point



- Maintenance alert warns when smoke detector dust accumulation is excessive
- One-person audible or silent walktest with walktest log & printout
- System alarm verification selection per detector point
- PAS (Positive Alarm Sequence) and Pre-signal per point (NFPA 72 compliant)
- Up to 16 ANN-BUS annunciators- 8 per each ANN-Bus
- Remote Acknowledge, Alarm Silence, Reset and Drill via addressable modules or remote annunciator
- Upload/Download of program and data via USB with optional FS-Tools Programming Utility

SLC COMMUNICATION LOOP

- Supports LiteSpeed™ and CLIP protocols
- SLC operates up to 10,000 ft. (3,000 m) in LiteSpeed mode with twisted, unshielded wire
- Single addressable SLC loop which meets NFPA Class B and Class A requirements
- 50 addressable device capacity (any combination of addressable detectors and modules)
- Compatible with Fire•Lite's addressable devices (refer to the *SLC Wiring Manual*)

NOTIFICATION APPLIANCE CIRCUITS (NACS)

- Two independently programmable output circuits. Circuits can be configured for the following outputs:
 - **Style Y** (Class B)
 - **Style Z** (Class A)
 - Silence Inhibit and Autosilence timer options
 - Continuous, March Time, Temporal, or California code for main circuit board NACs with two-stage capability
 - Selectable strobe synchronization per NAC
 - 2.5 A special application, 250mA regulated, total power for NACs
- NOTE:** Maximum or total 24VDC system power shared between all NAC circuits and the ANN-BUS is 2.7 A

PROGRAMMING AND SOFTWARE

- Autoprogramming (learn mode) reduces installation time

- Custom English labels (per point) may be manually entered or selected from an internal library file
- Two programmable Form-C relay outputs
- 50 software zones
- Continuous fire protection during online programming
- Program Check automatically catches common errors not linked to any zone or input point
- **OFFLINE PROGRAMMING:** Create the entire program in your office using FS-Tools, a Windows®-based software package, and upload/download system programming locally. Offline programming requires an ethernet connection. FS-Tools is available on www.firelite.com.

User interface

LED INDICATORS

- Fire Alarm (red)
- CO Alarm (red)
- AC Power (green)
- Supervisory (yellow)
- Trouble (yellow)
- Ground fault (yellow)
- Battery fault (yellow)
- Disabled (yellow)
- Maintenance (yellow)
- Communication (yellow)
- Alarm Silenced (yellow)
- F1-F4 Programmable Function Keys (yellow)

KEYPAD

- 16 key alpha-numeric pad
- Acknowledge
- Alarm Silence
- Drill (Manual Evacuate)
- Four (4) programmable function keys
- Reset (lamp test)

Product Line Information

ES-50X: Addressable Fire Alarm Control Panel with one SLC loop. Includes main circuit board with display, pre-installed IPOTS-COM communicator, chassis with transformer, backbox with door, plastic bag containing screws, cables, key, etc. (For ES-50XC, refer to DF-60954.)

FS-Tools: Programming software for Windows®-based PC computer. Available for download at www.firelite.com.

CELL-CAB-FL/CELL-MOD: Optional GSM communicators.

IPOTS-COM: Dual technology (POTS and IP) communicator. (replacement board)

DP-ES-R: Optional dress panel for the ES-50X.

TR-CE: Optional trim ring for semi-flush mounting.

BB-2F: Optional cabinet for one or two modules.

BB-6F: Optional cabinet for up to six modules mounted on CHS-6 chassis.

BB-26: Battery backbox, holds up to two 25 AH batteries & CHG-75.

BB-55F: Battery box, houses two 55 AH batteries

CHS-6: Chassis, mounts up to six multi-modules in a BB-6F cabinet.

CHG-75: Battery charger for lead-acid batteries with a rating of 25 to 75 AH.

CHG-120F: Remote battery charging system for lead-acid batteries with a rating of 55 to 120 AH. Requires additional BB-55F for mounting.

BAT Series: Batteries, see data sheet DF-52397.

PRN Series: UL listed compatible event printer. Uses tractor-fed paper.

OPTIONAL MODULES

4XTMF Reverse Polarity Transmitter Module: Provides a supervised output for local energy municipal box transmitter, alarm and trouble. Includes a disable switch and disable trouble LED.

COMPATIBLE ANNUNCIATORS

ANN-80: Remote, red LCD annunciator mimics the information displayed on the FACP LCD display. Recommended wire type is unshielded.

ANN-100: Remote LCD annunciator mimics the information displayed on the FACP LCD display. Recommended wire type is unshielded. For use in FM applications only.

ANN-I/O: LED Driver Module provides connections to a user supplied graphic annunciator. (See DF-52430.)

ANN-LED: Annunciator Module provides three LEDs for each zone: Alarm, Trouble, and Supervisory. Ships with red enclosure. (See DF-60241.)

ANN-RLED: Provides alarm (red) indicators for up to 30 input zones or addressable points. (See DF-60241.)

ANN-RLY: Relay Module provides 10 programmable Form-C relays. Can be mounted inside the cabinet. (See DF-52431.)

ANN-S/PG: Serial/Parallel Printer Gateway module provides a connection for a serial or parallel printer. (See DF-52429.)

ADDRESSABLE DEVICES

All feature a polling LED and rotary switches for addressing.

SD365: Addressable low-profile photoelectric smoke detector. LiteSpeed only.

SD365-IV: Addressable low-profile photoelectric smoke detector. Ivory. LiteSpeed and CLIP mode.

SD365T: Addressable low-profile photoelectric smoke detector with thermal sensor. LiteSpeed only.

SD365T-IV: Addressable low-profile photoelectric smoke detector with thermal sensor. Ivory. LiteSpeed and CLIP mode.

SD365R: Remote test capable addressable photoelectric smoke detector for use with DNR(W) duct detector housing. LiteSpeed only.

SD365R-IV: Remote test capable addressable photoelectric smoke detector for use with DNR(W) duct detector housing. Ivory. LiteSpeed and CLIP mode.

H365: Low-profile 135°F fixed thermal sensor. LiteSpeed only.

H365-IV: Low-profile 135°F fixed thermal sensor. Ivory. LiteSpeed and CLIP mode.

H365R: Low-profile, intelligent, rate-of-rise thermal sensor. LiteSpeed only.

H365R-IV: Low-profile, intelligent, rate-of-rise thermal sensor. Ivory. LiteSpeed and CLIP mode.

H365HT: Low-profile intelligent 190°F/88°C fixed thermal sensor. LiteSpeed only.

H365HT-IV: Low-profile intelligent 190°F/88°C fixed thermal sensor. Ivory. LiteSpeed and CLIP mode.

Legacy Devices

SD355: Addressable low-profile photoelectric smoke detector.

SD355T: Addressable low-profile photoelectric smoke detector with thermal sensor.

SD355R: Remote test capable addressable photoelectric smoke detector for use with DNR(W) duct detector housing.

SD355CO: Addressable, low-profile device that provides fire, heat, and carbon monoxide (CO) detection.

H355: Fast-response, low-profile heat detector.

H355R: Fast-response, low-profile heat detector with rate-of-rise option.

H355HT: Fast-response, low-profile heat detector that activates at 190°F/88°C.

AD355: Low-profile, intelligent, "Adapt" multi-sensor detector (B350LP base included).

B200S: Programmable, addressable sounder base

B200SR: Addressable sounder base.

BEAM355: Intelligent beam smoke detector.

BEAM355S: Intelligent beam smoke detector with integral sensitivity test.

D355PL: InnovairFlex low-flow non-relay duct-detector housing; includes SD355R.

DNR: InnovairFlex low-flow non-relay duct-detector housing. (Order SD355R/SD365R separately.)

DNRW: InnovairFlex low-flow non-relay duct-detector housing, with NEMA-4 rating. Watertight. (Order SD355R/SD365R separately.)

Addressable Modules

MMF-300: Addressable Monitor Module for one zone of normally-open dry-contact initiating devices. Mounts in standard 4.0" (10.16 cm.) box. Includes plastic cover plate and end-of-line resistor. Module may be configured for either a Style B (Class B) or Style D (Class A) IDC.

MDF-300: Dual Monitor Module. Same as MMF-300 except it provides two Style B (Class B) only IDCs.

MMF-301: Miniature version of MMF-300. Excludes LED and Style D option. Connects with wire pigtailed. May mount in device backbox.

MMF-302: Similar to MMF-300. Addressable Monitor Module for one zone of conventional two-wire detectors. Requires resettable 24 VDC power. Refer to the *Device Compatibility Document* for listed compatible devices and quantity limitation.

CMF-300: Addressable Control Module for one Style Y/Z (Class B/A) zone of supervised polarized Notification Appliances. Mounts directly to a 4.0" (10.16 cm.) electrical box. NAC option requires external 24 VDC to power notification appliances.

CRF-300: Addressable relay module containing two isolated sets of Form-C contacts, which operate as a DPDT switch. Mounts directly to a 4.0" (10.16 cm.) box, surface mount using the SMB500.

BG-12LX: Addressable manual pull station with interface module mounted inside.

I300: This module isolates the SLC loop from short circuit conditions (required for Style 6 or 7 operation).

ISO-6: Six-fault isolator module. Mount one or two modules in a BB-2F cabinet (optional). Mount up to six modules on a CHS-6 chassis in a BB-6F cabinet.

SMB500: Used to mount all modules except MMF-301 and M301.

MMF-300-10: Ten-input monitor module. Mount one or two modules in a BB-2F cabinet (optional). Mount up to six modules on a CHS-6 chassis in a BB-6F cabinet.

MMF-302-6: Six-zone interface module. Mount one or two modules in a BB-2F cabinet (optional). Mount up to six modules on a CHS-6 chassis in a BB-6F cabinet.

CMF-300-6: Six-circuit supervised control module. Mount one or two modules in a BB-2F cabinet (optional). Mount up to six modules on a CHS-6 chassis in a BB-6F cabinet.

CRF-300-6: Six-relay control module (Form-C relays). Mount one or two modules in a BB-2F cabinet (optional). Mount up to six modules on a CHS-6 chassis in a BB-6F cabinet.

SWIFT Wireless Devices

W-GATE: LiteSpeed Wireless Gateway

W-SD355: LiteSpeed intelligent, wireless photo detector.

W-H355R: LiteSpeed intelligent wireless rate of rise (135°) heat detector.

W-SD355T: intelligent wireless photo/heat detector.

W-H355: LiteSpeed intelligent wireless fixed-temperature (135°) heat detector.

W-MMF: LiteSpeed Intelligent wireless monitor module.

W-CRF: LiteSpeed Intelligent wireless relay module.

W-BG12LX: LiteSpeed Intelligent wireless pull station.

WAV-RL, WAV-WL, WAV-CRL, WAV-CWL: LiteSpeed Intelligent AV bases.

W-USB: Wireless USB radio/antenna dongle that plugs into the USB port of a PC running SWIFT Tools.

SWIFT Tools: Programming and diagnostic utility for the Wireless Gateway and devices. Available for download from firelite.com.

NOTE: For more information on Compatible Addressable Devices for use with the ES-50X, see the following data sheets (document numbers): SD365 Series (DF-61010), H365 Series (DF-61011), AD355 (DF-52386), BG-12LX (DF-52013), CMF-300-6 (DF-52365), CRF-300-6 (DF-52374), CMF/CRF Series (DF-52130), CP355 (DF-52383), H355 Series (DF-52385), I300 (DF-52389), ISO-6 (DF-60485), MMF-300 Series/MDF-300 (DF-52121), MMF-300-10 (DF-52347), MMF-302-6 (DF-52356), SD355/SD355T (DF-52384), and SLC Wiring Manual (51309).

NOTE: Legacy 300 Series detection devices such as the CP300/CP350, SD300(T)/SD350(T) and older modules such as the M300, M301, M302, C304, and BG-10LX are not compatible with LiteSpeed polling. If the SLC contains one of these devices, polling must be set for standard CLIP protocol. Please consult factory for further information on previous 300 Series devices.

ADDRESSABLE DEVICE ACCESSORIES

End-of-Line Resistor Assembly (R-47K and R-3.9K): The 47k ohm assembly supervises the MMF-300, MDF-300, MMF-301, and CMF-300 module circuits. The 3.9k ohm assembly supervises the MMF-302 module circuit. These resistors are included with each module.

Power Supervision Relay: Supervises the power to 4-wire smoke detectors and notification appliances.

Wiring Requirements

While shielded wire is not required, it is recommended that all SLC wiring be twisted-pair to minimize the effects of electrical interference. Refer to the panel manual for wiring details.

SYSTEM SPECIFICATIONS

System Capacity

- Intelligent Signaling Line Circuits..... 1
- Addressable device capacity..... 50
- Programmable software zones..... 50
- Annunciators..... 16

Electrical Specifications

AC Power: Operates in either 120 or 240 VAC, 50/60 Hz, 3.25 A, auto-sensing- no switch required. Wire size: minimum 14 AWG (2.00 mm²) with 600 V insulation. Nonpower-limited, supervised.

Battery: Two 12 V 18 AH lead-acid batteries. Battery Charger Capacity: 7-18 AH (ES-50X cabinet holds maximum of two 18 AH batteries.)

Communication Loop: Supervised and power-limited.

Notification Appliance Circuits: Terminal Block provides connections for two NACs, Style Y (Class B) or Style Z (Class A). Special Application power. Power-limited, supervised circuitry. Maximum signaling current per circuit: 2.5 amps special application, 250mA regulated. End-of-Line Resistor: 4.7k ohm, ½ watt (P/N 71252 UL listed) for Style Y (Class B) NAC; system capable of 1.9 kΩ - 22 kΩ ELR range. Refer to the *Fire•Lite Device Compatibility Document* for listed compatible devices.

Two Programmable Relays and One Fixed Trouble Relay: Contact rating: 2.0 A @ 30 VDC (resistive), 0.5 A @ 30 VAC (resistive). Form-C relays, non-power-limited, non-supervised.

Cabinet Specifications

Door: 19.26" (48.92 cm.) high x 16.82" (42.73 cm.) wide x 0.72" (1.82 cm.) deep. **Backbox:** 19.00" (48.26 cm.) high x 16.65" (42.29 cm.) wide x 5.25" (13.34 cm.) deep. **Trim Ring (TR-CE):** 22.00" (55.88 cm.) high x 19.65" (49.91 cm.) wide.

Shipping Specifications

Weight: 26.9 lbs. (12.20 kg.) **Dimensions:** 20.00" (50.80 cm.) high x 22.5" (57.15 cm.) wide x 8.5" (21.59 cm.) deep.

Temperature and Humidity Ranges

This system meets NFPA requirements for operation at 0 – 49°C/32 – 120°F and at a relative humidity 93% ± 2% RH (noncondensing) at 32°C ± 2°C (90°F ± 3°F). However, the useful life of the system's standby batteries and the electronic components may be adversely affected by extreme temperature ranges and humidity. Therefore, it is recommended that this system and its peripherals be installed in an environment with a normal room temperature of 15 – 27°C/60 – 80°F.

NFPA Standards

The ES-50X complies with the following NFPA 72 Fire Alarm Systems requirements:

- **LOCAL** (Automatic, Manual, Waterflow and Sprinkler Supervisory).
- **AUXILIARY** (Automatic, Manual and Waterflow) (requires 4XTMF).
- **REMOTE STATION** (Automatic, Manual and Waterflow) (Where a DACT is not accepted, the alarm, trouble and supervisory relays may be connected to UL 864 listed transmitters. For reverse polarity signaling of alarm and trouble, 4XTMF is required.)
- **PROPRIETARY** (Automatic, Manual and Waterflow).
- **CENTRAL STATION** (Automatic, Manual and Waterflow, and Sprinkler Supervised).
- **OT, PSDN** (Other Technologies, Packet-switched Data Network)
- **IBC 2012, IBC 2009, IBC 2006, IBC 2003, IBC 2000** (Seismic).
- **CBC 2007** (Seismic)

Agency Listings and Approvals

The listings and approvals below apply to the basic ES-50X control panel. In some cases, certain modules may not be listed by certain approval agencies, or listing may be in process. Consult factory for latest listing status.

- **UL:** S624
- **FM approved**
- **CSFM:** 7165-0075:0500
- **FDNY:** COA #6261

NOTE: See DF-60954 for ULC-listed model.

AlarmNet®, Fire-Lite® Alarms, SWIFT®, and System Sensor® are registered trademarks of Honeywell International Inc. Microsoft® and Windows® are registered trademarks of the Microsoft Corporation.
©2018 by Honeywell International Inc. All rights reserved. Unauthorized use of this document is strictly prohibited.



This document is not intended to be used for installation purposes.
We try to keep our product information up-to-date and accurate.
We cannot cover all specific applications or anticipate all requirements.
All specifications are subject to change without notice.

For more information, contact Fire•Lite Alarms. Phone: (800) 627-3473, FAX: (877) 699-4105.
www.firelite.com

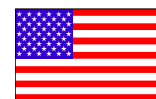

Country of Origin: USA

Note 1: You are fully responsible for verifying these calculations.
 Note 2: Use the dropdowns in the yellow cells to enter values.



ES-50X Battery Calculation

Secondary Power Source Requirements

Device	Standby Current (amps)				Secondary Alarm Current (amps)			
	Qty		Current Draw	Total	Qty		Current Draw	Total
Main Circuit Board	1	x	0.141000	= 0.141000	1	x	0.257000	= 0.257000
IPOTS-COM Communicator	0	x	0.040000	=	0	x	0.041000	=
4XTMF	0	x	0.005000	=	0	x	0.011000	=
EOLR-1	0	x	0.020000	=	0	x	0.020000	=
CELL-MOD-FL / CELL-CAB	1	x	0.055000	= 0.055000	1	x	0.100000	= 0.100000
ANN-BUS Devices								
ANN-SEC Card	0	x	0.003000	=	0	x	0.003000	=
ANN-80(-W)	0	x	0.015000	=	0	x	0.040000	=
ANN-100	0	x	0.020000	=	0	x	0.025000	=
ANN-(R)LED	0	x	0.028000	=	0	x	0.068000	=
ANN-RLY	0	x	0.015000	=	0	x	0.075000	=
ANN-I/O	0	x	0.035000	=	0	x	0.200000	=
ANN-I/O LED	0	x	0.000000	=	0	x	0.010000	=
ANN-S/PG	0	x	0.045000	=	0	x	0.045000	=
Addressable Devices								
BEAM355	0	x	0.002000	=				
BEAM355S	0	x	0.002000	=				
CP355	0	x	0.000300	=				
SD365CO	0	x	0.002000	=				
SD355CO	0	x	0.000300	=				
SD355	0	x	0.000300	=				
SD365	1	x	0.000200	= 0.000200				
SD355T	0	x	0.000300	=				
SD365T	0	x	0.000200	=				
H355	0	x	0.000300	=				
H365	0	x	0.000200	=				
H355HT	0	x	0.000300	=				
H365HT	0	x	0.000200	=				
H350R	0	x	0.000300	=				
H355R	0	x	0.000300	=				
H365R	0	x	0.000200	=				
D350RPL	0	x	0.000300	=				
D355PL	0	x	0.000300	=				
MMF-300	3	x	0.000375	= 0.001125				
MMF-300-10	0	x	0.003500	=				
MDF-300	0	x	0.000750	=				
MMF-301	0	x	0.000350	=				
MMF-302	0	x	0.000270	=				
MMF-302-6	0	x	0.002000	=				
BG-12LX	3	x	0.000375	= 0.001125				
CMF-300	0	x	0.000390	=				
CMF-300-6	0	x	0.002250	=				
CRF-300	0	x	0.000255	=				
CRF-300-6	0	x	0.001450	=				
CDRM-300	0	x	0.001300	=				
I300	0	x	0.000400	=				
ISO-6	0	x	0.002700	=				
B501BH-2	0	x	0.001000	=				
B501BHT-2	0	x	0.001000	=				
B224RB	0	x	0.000500	=				
B224BI	0	x	0.000450	=				
W-GATE	0	x	0.024000	=				
Maximum alarm draw for all Addressable devices ----->								0.20000
Resettable Power								
4-Wire Smoke Detectors	0	x	0.000000	=	0	x	0.000000	=
SWIFT Wireless								
W-GATE	0	x	0.040000	=	0	x	0.040000	=
Auxiliary Power								
CMF-300 (Aux. Power)	0	x	0.001700	=	0	x	0.007000	=
CMF-300-6 (Aux. Power)	0	x	0.008000	=	0	x	0.020000	=
MMF-302 (Aux. Power)	0	x	0.012000	=	0	x	0.090000	=
MMF-302-6 (Aux. Power)	0	x	0.050000	=	0	x	0.270000	=
B200SR (Aux. Power)	0	x	0.000500	=	0	x	0.035000	=
B200SR-LF (Aux. Power)	0	x	0.001000	=	0	x	0.125000	=

Miscellaneous Devices										
	0	x	0.000000	=		0	x	0.000000	=	
	0	x	0.000000	=		0	x	0.000000	=	
	0	x	0.000000	=		0	x	0.000000	=	
	0	x	0.000000	=		0	x	0.000000	=	
	0	x	0.000000	=		0	x	0.000000	=	
Output Circuits										
NAC/Output #1			0.000000	=				0.000000	=	
NAC/Output #2			0.000000	=				0.000000	=	
FCPS (remote Sync)	0	x	0.000000	=		0	x	0.021700	=	
Total Standby Load			0.198450		Total Alarm Load			0.557000		

		ES-50X Battery Calculation			
Calculation in Total Sheet					
		Required Standby Time in Hours			
		24 Hours			
Total Standby Current	0.1985 Amps	x	24	=	4.763 AH
		Required Alarm Time in Minutes			
		5 Minutes			
Total Alarm Load	0.5570 Amps	x	0.084	=	0.047 AH
		Total Current Load			
		4.810 AH			
Multiply by the Derating Factor		1.2	=	x 1.20	
		Total Ampere Hours Required			
		5.77 AH			
Recommended Batteries:		BAT-1270 - 7AH Batteries			

Battery Check
 The batteries can be charged by the ES-50X Charger.
 The batteries can be housed in the ES-50X Cabinet.

Current Draw Check
 NAC#1 current is within the limitations of the circuit.
 NAC#2 current is within the limitations of the circuit.
 ES-50X current draw:
 The required output current is within the panel's limitations

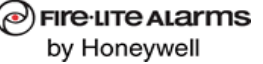
		ES-50X Circuit Detail								
NAC/Output #1										
Device	Qty	Non-Alarm Draw	Total	Qty	Alarm Draw	Total				
SRL 15	0	x	0.000000	=	0	x	0.043000	=		
P2RL 15	0	x	0.000000	=	0	x	0.054000	=		
P2RL 110	0	x	0.000000	=	0	x	0.162000	=		
P2RK 110	0	x	0.000000	=	0	x	0.212000	=		
		x	0.000000	=	0	x	0.166000	=		
	0	x	0.000000	=	0	x	0.000000	=		
	0	x	0.000000	=	0	x	0.000000	=		
	0	x	0.000000	=	0	x	0.000000	=		
	0	x	0.000000	=	0	x	0.000000	=		
	0	x	0.000000	=	0	x	0.000000	=		
Total Standby Load			0.000000		Total Alarm Load			0.000000		

NAC/Output #2										
Device	Qty	Non-Alarm Draw	Total	Qty	Alarm Draw	Total				
SRL 15	0	x	0.000000	=	0	x	0.043000	=		
P2RL 15	0	x	0.000000	=	0	x	0.054000	=		
P2RL 110	0	x	0.000000	=	0	x	0.162000	=		
PC2RK 30	0	x	0.000000	=	0	x	0.107000	=		
PC2RK 75	0	x	0.000000	=	0	x	0.176000	=		
HW-LF	0	x	0.000000	=	0	x	0.166000	=		
	0	x	0.000000	=	0	x	0.000000	=		
	0	x	0.000000	=	0	x	0.000000	=		
	0	x	0.000000	=	0	x	0.000000	=		
	0	x	0.000000	=	0	x	0.000000	=		
Total Standby Load			0.000000		Total Alarm Load			0.000000		



Power Supplies
FL-PS6(C) & FL-PS10(C)
Instruction Manual



Fire Alarm & Emergency Communication System Limitations

While a life safety system may lower insurance rates, it is not a substitute for life and property insurance!

An automatic fire alarm system—typically made up of smoke detectors, heat detectors, manual pull stations, audible warning devices, and a fire alarm control panel (FACP) with remote notification capability—can provide early warning of a developing fire. Such a system, however, does not assure protection against property damage or loss of life resulting from a fire.

An emergency communication system—typically made up of an automatic fire alarm system (as described above) and a life safety communication system that may include an autonomous control unit (ACU), local operating console (LOC), voice communication, and other various interoperable communication methods—can broadcast a mass notification message. Such a system, however, does not assure protection against property damage or loss of life resulting from a fire or life safety event.

The Manufacturer recommends that smoke and/or heat detectors be located throughout a protected premises following the recommendations of the current edition of the National Fire Protection Association Standard 72 (NFPA 72), manufacturer's recommendations, State and local codes, and the recommendations contained in the Guide for Proper Use of System Smoke Detectors, which is made available at no charge to all installing dealers. This document can be found at <http://www.systemsensor.com/appguides/>. A study by the Federal Emergency Management Agency (an agency of the United States government) indicated that smoke detectors may not go off in as many as 35% of all fires. While fire alarm systems are designed to provide early warning against fire, they do not guarantee warning or protection against fire. A fire alarm system may not provide timely or adequate warning, or simply may not function, for a variety of reasons:

Smoke detectors may not sense fire where smoke cannot reach the detectors such as in chimneys, in or behind walls, on roofs, or on the other side of closed doors. Smoke detectors also may not sense a fire on another level or floor of a building. A second-floor detector, for example, may not sense a first-floor or basement fire.

Particles of combustion or "smoke" from a developing fire may not reach the sensing chambers of smoke detectors because:

- Barriers such as closed or partially closed doors, walls, chimneys, even wet or humid areas may inhibit particle or smoke flow.
- Smoke particles may become "cold," stratify, and not reach the ceiling or upper walls where detectors are located.
- Smoke particles may be blown away from detectors by air outlets, such as air conditioning vents.
- Smoke particles may be drawn into air returns before reaching the detector.

The amount of "smoke" present may be insufficient to alarm smoke detectors. Smoke detectors are designed to alarm at various levels of smoke density. If such density levels are not created by a developing fire at the location of detectors, the detectors will not go into alarm.

Smoke detectors, even when working properly, have sensing limitations. Detectors that have photoelectronic sensing chambers tend to detect smoldering fires better than flaming fires, which have little visible smoke. Detectors that have ionizing-type sensing chambers tend to detect fast-flaming fires better than smoldering fires. Because fires develop in different ways and are often unpredictable in their growth, neither type of detector is necessarily best and a given type of detector may not provide adequate warning of a fire.

Smoke detectors cannot be expected to provide adequate warning of fires caused by arson, children playing with matches (especially in bedrooms), smoking in bed, and violent explosions (caused by escaping gas, improper storage of flammable materials, etc.).

Heat detectors do not sense particles of combustion and alarm only when heat on their sensors increases at a predetermined rate or reaches a predetermined level. Rate-of-rise heat detectors may

year by a qualified fire protection specialist. Heat detectors are designed to protect property, not life.

IMPORTANT! Smoke detectors must be installed in the same room as the control panel and in rooms used by the system for the connection of alarm transmission wiring, communications, signaling, and/or power. If detectors are not so located, a developing fire may damage the alarm system, compromising its ability to report a fire.

Audible warning devices such as bells, horns, strobes, speakers and displays may not alert people if these devices are located on the other side of closed or partly open doors or are located on another floor of a building. Any warning device may fail to alert people with a disability or those who have recently consumed drugs, alcohol, or medication. Please note that:

- An emergency communication system may take priority over a fire alarm system in the event of a life safety emergency.
- Voice messaging systems must be designed to meet intelligibility requirements as defined by NFPA, local codes, and Authorities Having Jurisdiction (AHJ).
- Language and instructional requirements must be clearly disseminated on any local displays.
- Strobes can, under certain circumstances, cause seizures in people with conditions such as epilepsy.
- Studies have shown that certain people, even when they hear a fire alarm signal, do not respond to or comprehend the meaning of the signal. Audible devices, such as horns and bells, can have different tonal patterns and frequencies. It is the property owner's responsibility to conduct fire drills and other training exercises to make people aware of fire alarm signals and instruct them on the proper reaction to alarm signals.
- In rare instances, the sounding of a warning device can cause temporary or permanent hearing loss.

A life safety system will not operate without any electrical power. If AC power fails, the system will operate from standby batteries only for a specified time and only if the batteries have been properly maintained and replaced regularly.

Equipment used in the system may not be technically compatible with the control panel. It is essential to use only equipment listed for service with your control panel.

Alarm Signaling Communications:

- **IP connections** rely on available bandwidth, which could be limited if the network is shared by multiple users or if ISP policies impose restrictions on the amount of data transmitted. Service packages must be carefully chosen to ensure that alarm signals will always have available bandwidth. Outages by the ISP for maintenance and upgrades may also inhibit alarm signals. For added protection, a backup cellular connection is recommended.
- **Cellular connections** rely on a strong signal. Signal strength can be adversely affected by the network coverage of the cellular carrier, objects and structural barriers at the installation location. Utilize a cellular carrier that has reliable network coverage where the alarm system is installed. For added protection, utilize an external antenna to boost the signal.
- **Telephone lines** needed to transmit alarm signals from a premise to a central monitoring station may be out of service or temporarily disabled. For added protection against telephone line failure, backup alarm signaling connections are recommended.

The most common cause of life safety system malfunction is inadequate maintenance. To keep the entire life safety system in excellent working order, ongoing maintenance is required per the manufacturer's recommendations, and UL and NFPA standards. At a minimum, the requirements of NFPA 72 shall be followed. Environments with large amounts of dust, dirt, or high air velocity require more frequent maintenance. A maintenance agreement should be arranged through the local manufacturer's representative. Maintenance should be scheduled as required by National and/or local fire codes and should be performed by authorized professional

Installation Precautions

Adherence to the following will aid in problem-free installation with long-term reliability:

WARNING - Several different sources of power can be connected to the fire alarm control panel. Disconnect all sources of power before servicing. Control unit and associated equipment may be damaged by removing and/or inserting cards, modules, or interconnecting cables while the unit is energized. Do not attempt to install, service, or operate this unit until manuals are read and understood.

CAUTION - System Re-acceptance Test after Software

Changes: To ensure proper system operation, this product must be tested in accordance with NFPA 72 after any programming operation or change in site-specific software. Re-acceptance testing is required after any change, addition or deletion of system components, or after any modification, repair or adjustment to system hardware or wiring. All components, circuits, system operations, or software functions known to be affected by a change must be 100% tested. In addition, to ensure that other operations are not inadvertently affected, at least 10% of initiating devices that are not directly affected by the change, up to a maximum of 50 devices, must also be tested and proper system operation verified.

This system meets NFPA requirements for operation at 0-49° C/ 32-120° F and at a relative humidity 93% ± 2% RH (non-condensing) at 32°C ± 2°C (90°F ± 3°F). However, the useful life of the system's standby batteries and the electronic components may be adversely affected by extreme temperature ranges and humidity. Therefore, it is recommended that this system and its peripherals be installed in an environment with a normal room temperature of 15-27° C/60-80° F.

Verify that wire sizes are adequate for all initiating and indicating device loops. Most devices cannot tolerate more than a 10% I.R. drop from the specified device voltage.

Like all solid state electronic devices, this system may operate erratically or can be damaged when subjected to lightning induced transients. Although no system is completely immune from lightning transients and interference, proper grounding will reduce susceptibility. Overhead or outside aerial wiring is not recommended, due to an increased susceptibility to nearby lightning strikes. Consult with the Technical Services Department if any problems are anticipated or encountered.

Disconnect AC power and batteries prior to removing or inserting circuit boards. Failure to do so can damage circuits.

Remove all electronic assemblies prior to any drilling, filing, reaming, or punching of the enclosure. When possible, make all cable entries from the sides or rear. Before making modifications, verify that they will not interfere with battery, transformer, or printed circuit board location.

Do not tighten screw terminals more than 9 in-lbs. Over-tightening may damage threads, resulting in reduced terminal contact pressure and difficulty with screw terminal removal.

This system contains static-sensitive components. Always ground yourself with a proper wrist strap before handling any circuits so that static charges are removed from the body. Use static suppressive packaging to protect electronic assemblies removed from the unit.

Units with a touchscreen display should be cleaned with a dry, clean, lint free/microfiber cloth. If additional cleaning is required, apply a small amount of Isopropyl alcohol to the cloth and wipe clean. Do not use detergents, solvents, or water for cleaning. Do not spray liquid directly onto the display.

Follow the instructions in the installation, operating, and programming manuals. These instructions must be followed to avoid damage to the control panel and associated equipment. FACP operation and reliability depend upon proper installation.

Precau-D2-11-2017

FCC Warning

WARNING: This equipment generates, uses, and can radiate radio frequency energy and if not installed and used in accordance with the instruction manual may cause interference to radio communications. It has been tested and found to comply with the limits for class A computing devices pursuant to Subpart B of Part 15 of FCC Rules, which is designed to provide reasonable protection against such interference when devices are operated in a commercial environment. Operation of this equipment in a residential area is likely to cause interference, in which case the user will be required to correct the interference at his or her own expense.

Canadian Requirements

This digital apparatus does not exceed the Class A limits for radiation noise emissions from digital apparatus set out in the Radio Interference Regulations of the Canadian Department of Communications.

Le présent appareil numérique n'émet pas de bruits radioélectriques dépassant les limites applicables aux appareils numériques de la classe A prescrites dans le Règlement sur le brouillage radioélectrique édicté par le ministère des Communications du Canada.

LiteSpeed™ and Lite-Connect™ are trademarks; and Fire-Lite® Alarms, Honeywell®, and SWIFT® are registered trademarks of Honeywell International Inc. Microsoft® and Windows® are registered trademarks of the Microsoft Corporation. Chrome™ and Google™ are trademarks of Google Inc. Firefox® is a registered trademark of The Mozilla Foundation.

©2021 by Honeywell International Inc. All rights reserved. Unauthorized use of this document is strictly prohibited.

Software Downloads

In order to supply the latest features and functionality in fire alarm and life safety technology to our customers, we make frequent upgrades to the embedded software in our products. To ensure that you are installing and programming the latest features, we strongly recommend that you download the most current version of software for each product prior to commissioning any system. Contact Technical Support with any questions about software and the appropriate version for a specific application.

Documentation Feedback

Your feedback helps us keep our documentation up-to-date and accurate. If you have any comments or suggestions about our online Help or printed manuals, you can email us.

Please include the following information:

- Product name and version number (if applicable)
- Printed manual or online Help
- Topic Title (for online Help)
- Page number (for printed manual)
- Brief description of content you think should be improved or corrected
- Your suggestion for how to correct/improve documentation

Send email messages to:

FireSystems.TechPubs@honeywell.com

Please note this email address is for documentation feedback only. If you have any technical issues, please contact Technical Services.



This symbol (shown left) on the product(s) and / or accompanying documents means that used electrical and electronic products should not be mixed with general household waste. For proper treatment, recovery and recycling, contact your local authorities or dealer and ask for the correct method of disposal.

Electrical and electronic equipment contains materials, parts and substances, which can be dangerous to the environment and harmful to human health if the waste of electrical and electronic equipment (WEEE) is not disposed of correctly.

Table of Contents

Section 1: System Overview	8
1.1: General	8
1.2: Features	8
1.3: Specifications	8
1.4: Open/Short/Ground Fault Trip Values in Standby	9
1.5: Switch SW1 - Ground Fault Detection	10
1.6: Applications	11
1.7: Start-up Procedure	11
Section 2: Installation	12
2.1: Backbox Mounting	12
2.2: NAC Circuit Wiring	13
2.2.1: Class B	13
2.2.2: ZNAC-PS Class A Option Module	13
2.3: Addressable Module Mounting	14
2.4: NEC Power-limited (Class 2) Wiring Requirements	15
2.5: FACP with FL-PS Power Supply in Slave Mode	16
2.6: FL-PS Power Supply in Master Mode Connected to FACP	16
2.7: Connecting to an External Charger	17
2.7.1: CHG-120F	17
2.7.2: CHG-75	17
2.8: Cascading Multiple Units	18
2.9: Canadian Applications	19
Section 3: Programming Options	22
3.1: S1 Global Options DIP Switch	23
3.1.1: Global Programmable Features Description	23
Input Debounce/Dejitter/Delay	23
Command Input #1	24
Charger Enable/Disable	24
AC Loss Door Holder Dropout Timer	24
AC Fail Indication Delay	24
Special Operating Modes	24
3.2: Output Circuit Control DIP Switch Settings	25
3.2.1: Output Circuit Programmable Features Description	25
Command Inputs/NAC Circuits	25
Unused Outputs	26
Remote Supply with Resettable and Non-resettable Power	26
Door Holder	26
Synchronization Mode - Master/Slave	26
Master Mode - Selective Silence	27
Command Input #1 - Normal/Sync Mode of Operation	27
Class A Wiring	28
Section 4: LED Indicators	29
Section 5: Trouble Supervision	31
5.1: Trouble Supervision Using Input Circuits	31
5.2: Trouble Relay	31
5.3: AC Trouble Relay	31
5.4: Ground Fault Relay (Canadian Applications Only)	32
Section 6: Power Supply Requirements	33
6.1: Overview	33
6.2: Calculating the AC Branch Circuit	33
6.3: Calculating the System Current Draw	33
6.3.1: Overview	33
6.3.2: How to Calculate System Current Draw	34
6.4: Selecting and Locating Batteries	34
6.4.1: NFPA Battery Requirements	34
6.4.2: Maximum Battery Standby Load	35
Section 7: Testing and Maintenance	35
7.1: Periodic Testing and Service	35

7.2: Battery Checks and Maintenance35

Appendix A: Wire Requirements..... 36

Appendix B: Application Examples 37

B.1: Controlling NACs For Selective Silence Operation Using a Control Module37

B.2: Controlling NACs For Sync Follower Operation Using a Control Module38

B.3: Controlling NACs, Aux Power, or Door Holders Using a Control Module39

B.4: Controlling NACs, Aux Power, and Door Holders with NAC Sync40

B.5: Controlling all Three Inputs with One Control Module.....41

B.6: AC Trouble Reporting with a Conventional FACP.....42

B.7: Canadian Two-Stage43

B.8: Canada Two-Stage Application Using CMF-300-644

Index 45

It is imperative that the installer understand the requirements of the Authority Having Jurisdiction (AHJ) and be familiar with the standards set forth by the following regulatory agencies:

- Underwriters Laboratories Standards
- NFPA 72 National Fire Alarm Code

Before proceeding, the installer should be familiar with the following documents.



NFPA Standards

NFPA 72 National Fire Alarm Code
NFPA 70 National Electrical Code



Underwriters Laboratories Documents:

UL 464 Audible Signaling Appliances
UL 864 Standard for Control Units for Fire Protective Signaling Systems
UL 1638 Visual Signaling Appliances
UL 1971 Signaling Devices for Hearing Impaired
UL 2572 Standard for Mass Notification Systems



CAN/ULC - S524 Standard for Installation of Fire Alarm Systems
CAN/ULC - S527 Standard for Control Units for Fire Alarm Systems

Other:

NEC Article 250 Grounding
NEC Article 300 Wiring Methods
NEC Article 760 Fire Protective Signaling Systems
Applicable Local and State Building Codes
Requirements of the Local Authority Having Jurisdiction (LAHJ)
Canadian Electrical Code, Part 1

Other Fire•Lite Documents:

Device Compatibility Document	Document #15384
SLC Wiring Manual	Document #51309
CHG-75 Manual	Document #51315
CHG-120F Manual	Document #50888

This product has been certified to comply with the requirements in the Standard for Control Units and Accessories for Fire Alarm Systems, UL 864, 10th Edition. Operation of this product with products not tested for UL 864, 9th/10th Edition has not been evaluated. Such operation requires the approval of the local Authority Having Jurisdiction (AHJ).



This symbol (shown left) on the product(s) and / or accompanying documents means that used electrical and electronic products should not be mixed with general household waste. For proper treatment, recovery and recycling, contact your local authorities or dealer and ask for the correct method of disposal.

Electrical and electronic equipment contains materials, parts and substances, which can be dangerous to the environment and harmful to human health if the waste of electrical and electronic equipment (WEEE) is not disposed of correctly.

Section 1: System Overview

The FL-PS6 is a 6 amp and the FL-PS10 is a 10 amp remote power supply with battery charger. Both models provide ADA compatible strobe synchronization and a filtered 24 VDC output that can be configured to drive five (6 amp model) or seven (10 amp model) Class B NACs (Notification Appliance Circuits). NAC circuits can be configured for Class A wiring with the optional ZNAC-PS Class A converter module. NAC output circuits may be configured as 24 VDC resettable or non-resettable power outputs, or Class D door holder outputs. The input circuits, which control the power supply operation, are triggered by the reverse polarity of a NAC or by a 12 VDC or 24 VDC power source. The FL-PS power supplies are compatible with 12 VDC and 24 VDC control panels.

The FL-PS6C and FL-PS10C offer the same features as the FL-PS6 and FL-PS10 respectively, but are intended for Canadian applications and adds an additional relay for ground fault reporting. Unless otherwise specified, the information in this manual applies to all models.

1.1 General

FL-PS power supplies can be used as remotely mounted power supplies and battery chargers to power non-coded or coded NACs. The Main FACP (Fire Alarm Control Panel) NAC(s) is connected to the remote power supply input circuit(s). When the command input circuit activates due to reverse polarity of the NAC from the FACP, the power supply will activate its Notification Appliance Circuits.

During the inactive or non-alarm state, the power supply supervises its NAC field wiring for short and open conditions. AC fail, battery, charger and ground fault troubles will also be monitored by the power supply and will activate the AC Fail, Battery Fault, and Ground Fault relay, respectively. If a NAC fault is detected, the input end-of-line will open to indicate the fault to the main panel.

If an alarm condition occurs and the NAC is activated, the supervision is disabled and the Notification Appliance Circuit is no longer supervised (except for shorts). Supervision of other power supply faults such as low battery, overcharged battery, ground fault, and battery charger trouble will continue and will be monitored by their respective trouble relays.

1.2 Features

- Self-contained in a lockable cabinet
- 24 VDC remote power supply
- Outputs are completely power-limited (Class 2)
- Two (FL-PS6) or three (FL-PS10) optically-isolated input/command circuits, compatible with 12 VDC and 24 VDC control panel NACs
- Five (FL-PS6) or seven (FL-PS10) output circuits:
 - Fully filtered power
 - Five or seven 24 VDC Class B NACs
 - Optional ZNAC-PS Class A converter module for conversion to Class A NACs
 - Alternatively, all output circuits may be configured as 24 VDC special application power outputs or Class D door holder power outputs
 - Output circuits may be configured as resettable or non-resettable
- Individual NAC Power (red) and Trouble (yellow) LEDs for each output
- Maximum current available:
 - FL-PS6: TB8-TB9 – 1A Regulated, 3A special applications; TB10-TB12 – 0.3A Regulated, 3A special applications
 - FL-PS10: TB8-TB11 – 1.5A Regulated, 3A special applications; TB12-TB14 – 0.3A Regulated, 3A special applications
- Maximum total current available (alarm and standby):
 - 6.0 amps for FL-PS6 alarm; 3.0 amps standby
 - 10.0 amps for FL-PS10 alarm; 3.0 amps standby
- Integral supervised battery charger for lead acid batteries only
- Capable of charging 7.0 AH - 33.0 AH (Amp Hour) batteries (cabinet fits 7 or 18 AH batteries)
- Fully supervised power supply, battery and NACs
- Selectable Strobe Synchronization for NACs (System Sensor, Gentex, Wheelock, and Amseco)
- Coded signal synchronization
- Removable terminal blocks for field wiring capable of accepting 12 - 18 AWG wire
- Selectable Ground Fault detection by switch SW1
- LED trouble diagnostics and history
- Power supply trouble, AC Loss, and Ground Fault (Canadian models only) Form-C relay contacts (fail-safe)
- Optional delay of AC loss reporting for 0, 2, 12, or 30 hours
- Mounting location for optional addressable module
- Up to four PS Series units can be cascaded

1.3 Specifications

Refer to Figure 1.1 on page 10 for terminal locations.



NOTE: The FL-PS6 uses the same PCB layout as the FL-PS10, however some terminals will be depopulated, leaving the FL-PS6 with five output circuits and two input circuits.

Primary AC Power - TB4

- FL-PS6(C): 120 VAC, 50/60 Hz, 5.0 amps maximum

- FL-PS10(C): 120 VAC, 50/60 Hz, 6.2 amps maximum
- Wire size: #12-14 AWG wire with 600V insulation

Command Input Circuits - TB5, TB6, TB7

- Trigger Input Voltage: 9 - 32 VDC
- Input Current Draw in Alarm Polarity: 9 - 32 volts, 14.0 mA maximum per input

Output Circuits - TB8-TB14

- Supervised and power-limited
- Voltage Rating: 24 VDC filtered
- Current:
 - FL-PS6: TB8-TB9 – 1A Regulated, 3A special applications; TB10-TB12 – 0.3A Regulated, 3A special applications
 - FL-PS10: TB8-TB11 – 1.5A Regulated, 3A special applications; TB12-TB14 – 0.3A Regulated, 3A special applications
 - Maximum total alarm current for all output:
FL-PS6 - 6.0 amps
FL-PS10 - 10.0 amps
- Output Circuit Types:
 - Class B NACs (require 2k Ω - 27k Ω End-of-Line Resistors) and/or Class A NACs using the optional ZNAC-PS Class A converter module. Use Listed ELRs supplied by the FACP or compatible equipment manufacturer.
 - Resettable or non-resettable outputs for 24 VDC power outputs or Class D door holder (max ripple voltage: 780mV_{RMS})
- Refer to the *Fire•Lite Device Compatibility Document #15384* for listed compatible devices.
- For wiring requirements, refer to “Wire Requirements” on page 36.

Trouble, AC Loss, and Ground Fault (Canadian models only) Relay Contact Rating - TB1-TB3

- Fail-safe Form-C relay (normally energized, transfers with loss of power) for AC Loss and Trouble
- 4.0 amps @ 30 VDC resistive

Secondary Power (battery) Charging Circuit - TB15

- Supervised, non-power-limited
- Supports lead acid type batteries only
- Float Charge Voltage: 27.6 VDC
- Maximum Peak Charge Current: 2.47A
- Maximum Nominal Charge Current: 1.5 A
- Maximum Battery Capacity: 33.0 AH (with onboard battery charger)
- Minimum Battery Capacity: 7.0 AH



NOTE: The FL-PS only supports 7AH or 18AH batteries in the cabinet. Other battery capacities up to 33AH will not fit in the cabinet due to physical dimensions and require a separate battery cabinet.

1.4 Open/Short/Ground Fault Trip Values in Standby

Table 1.1 lists the earth fault resistance detection in standby for each applicable terminal on the FACP.

Output Circuit	Terminal	Trip Resistance (in ohms)
NAC 1-5/7	+	9.9K or lower
NAC 1-5/7	-	9.2K or lower
ZNAC-PS 1-5/7	+	9.9K or lower
ZNAC-PS 1-5/7	-	9K or lower

Table 1.1 Earth Fault Trip Values

Value of the resistance in between any circuit terminal to Earth, which will cause the Ground Fault detection, depends on the ELR chosen for inputs and output circuits. This resistance will vary from 9.9K down to 0 Ohm.

Table 1.2 lists the open/short trip values and restoral values in standby for the NAC circuits on the FACP.

Circuit	Fault	Trip Resistance (in ohms)	Restore Value
NAC 1-5/7	Short	1.6K or lower	1.7K or higher
NAC 1-5/7	Open	55K or higher	33K or lower
ZNAC-PS 1-5/7	Short	1.6K or lower	1.7K or higher
ZNAC-PS 1-5/7	Open	45K or higher	21K or lower

Table 1.2 NAC Open/Short Trip Values

1.5 Switch SW1 - Ground Fault Detection

The Ground Fault Detection circuit monitors for ground faults. Switch SW1 is located on the lower left section of the power supply circuit board. Sliding SW1 to the left will disable ground fault detection by the power supply. This should only be done if ground faults are being monitored by an FACP connected to the FL-PS power supply or in a cascading application as shown in Section 2.8 on page 18.

Note: The FL-PS6 uses the same PCB layout, however some terminals will be depopulated, leaving the FL-PS6 with five output circuits and two inputs circuits.

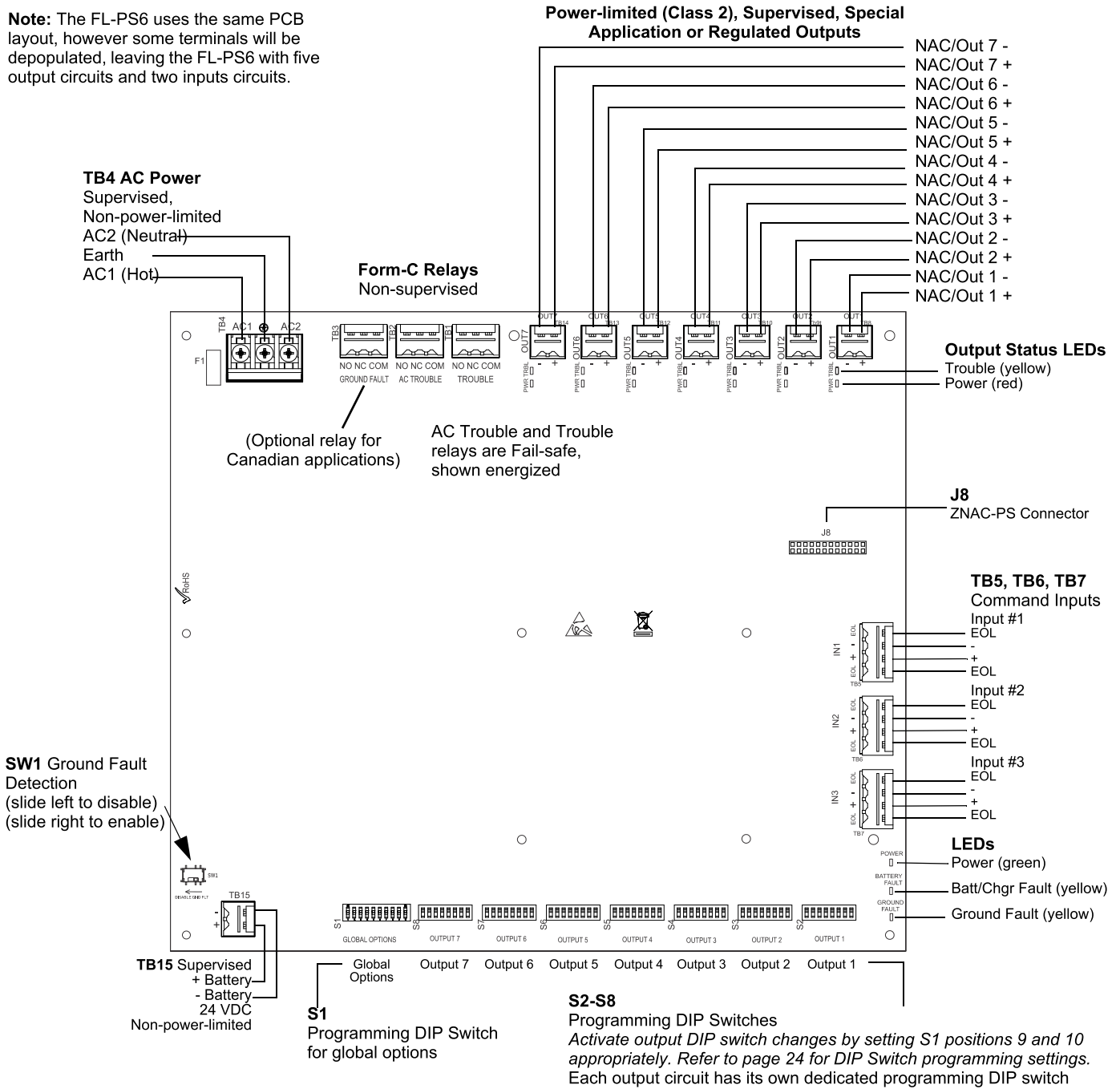

Figure 1.1 FL-PS10 Board Layout

1.6 Applications

The FL-PS may be used in a number of different applications. It may be used as a remotely-mounted power supply and battery charger where it can provide up to seven coded or non-coded, synchronized or non-synchronized NACs (Notification Appliance Circuits). Alternatively, any output can be used as a door holder circuit which will provide a steady 24 VDC output until an alarm condition or AC fail condition causes it to drop to 0 VDC following a selectable delay. See the DIP switch settings for S1 global options on page 23. All outputs can also provide power.

One possible application for the FL-PS remote power supply utilizes the NAC repeater feature. In this application, one or two NACs are connected from the main FACP to the remote power supply command input circuits. When the command input circuits are activated by the reverse polarity of the NACs, the power supply will activate its corresponding output circuits as programmed by its DIP switch configuration (refer to Table 3.7 on page 25).

During the inactive state, the remote power supply supervises its NAC field wiring for short and open conditions. If a fault is detected, the power supply will enter a trouble condition and illuminate the NAC Trouble LED. When the NACs are activated, the supervision is disabled and the circuits are no longer supervised (except for short circuit conditions). Supervision of other power supply faults such as low battery, battery charger trouble, ground fault and AC loss will continue and may be monitored via their respective trouble relay.

If an application requires that all outputs activate at the same time, only one NAC is required from the FACP. For this application, the NAC is connected to command input circuit #1 and the DIP switch is set for this operation.

1.7 Start-up Procedure

1. Configure the power supply switch as described in “Switch SW1 - Ground Fault Detection” on page 10.
2. Install the power supply as described in “Installation” on page 12.
3. Program the power supply as described in “Programming Options” on page 22.
4. Wire the power supply circuits, referring to the options described in “Trouble Supervision” on page 31 and the application examples in “Application Examples” on page 37.
5. Connect primary power source wiring while observing the following:
 - Ensure the AC mains circuit breaker is **off** before making any wiring connections between the mains and the power supply.
 - Make certain primary power source is:
120 VAC, 50/60 Hz, 5.0 (6 amp model) 6.2 amps (10 amp model) Run a pair of wires (with ground conductor) from the protected premises main breaker box to TB4 of the power supply main circuit board.
 - Use #12-14 AWG gauge wire with 600V insulation.
6. Apply power to the power supply using the following procedure:
 - Apply AC power by turning on the AC mains circuit breaker connected to the power supply.
 - Connect a properly charged battery to connector TB15 on the power supply main circuit board.
7. Clear trouble history using global DIP switch S1 positions 9 and 10. See DIP switch settings in Table 3.6 on page 24.

Section 2: Installation

Carefully unpack the system and check for shipping damage. Select a location for the cabinet that is in a clean, dry, vibration-free area where extreme temperatures are not encountered. The area should be readily accessible with sufficient room to easily install and maintain the power supply. With the hinge mounting on the left, determine the number of conductors required for the devices to be installed and determine the appropriate knockouts. All wiring must be in accordance with the National and/or Local codes for fire alarm systems and power supplies.

2.1 Backbox Mounting



CAUTION: STATIC SENSITIVE COMPONENTS

THE CIRCUIT BOARD CONTAINS STATIC-SENSITIVE COMPONENTS. ALWAYS GROUND YOURSELF WITH A PROPER WRIST STRAP BEFORE HANDLING ANY BOARDS SO THAT STATIC CHARGES ARE REMOVED FROM THE BODY. USE STATIC SUPPRESSIVE PACKAGING TO PROTECT ELECTRONIC ASSEMBLIES.

1. Mark and pre-drill holes for the top two keyhole mounting bolts.
2. Install two upper fasteners in the wall with the screw heads protruding approximately 1/4".
3. Using the upper keyholes, mount the backbox over the two screws.
4. Mark the lower two holes, remove the backbox from the wall and drill the mounting holes.
5. Mount the backbox, install the remaining fasteners and tighten all screws..

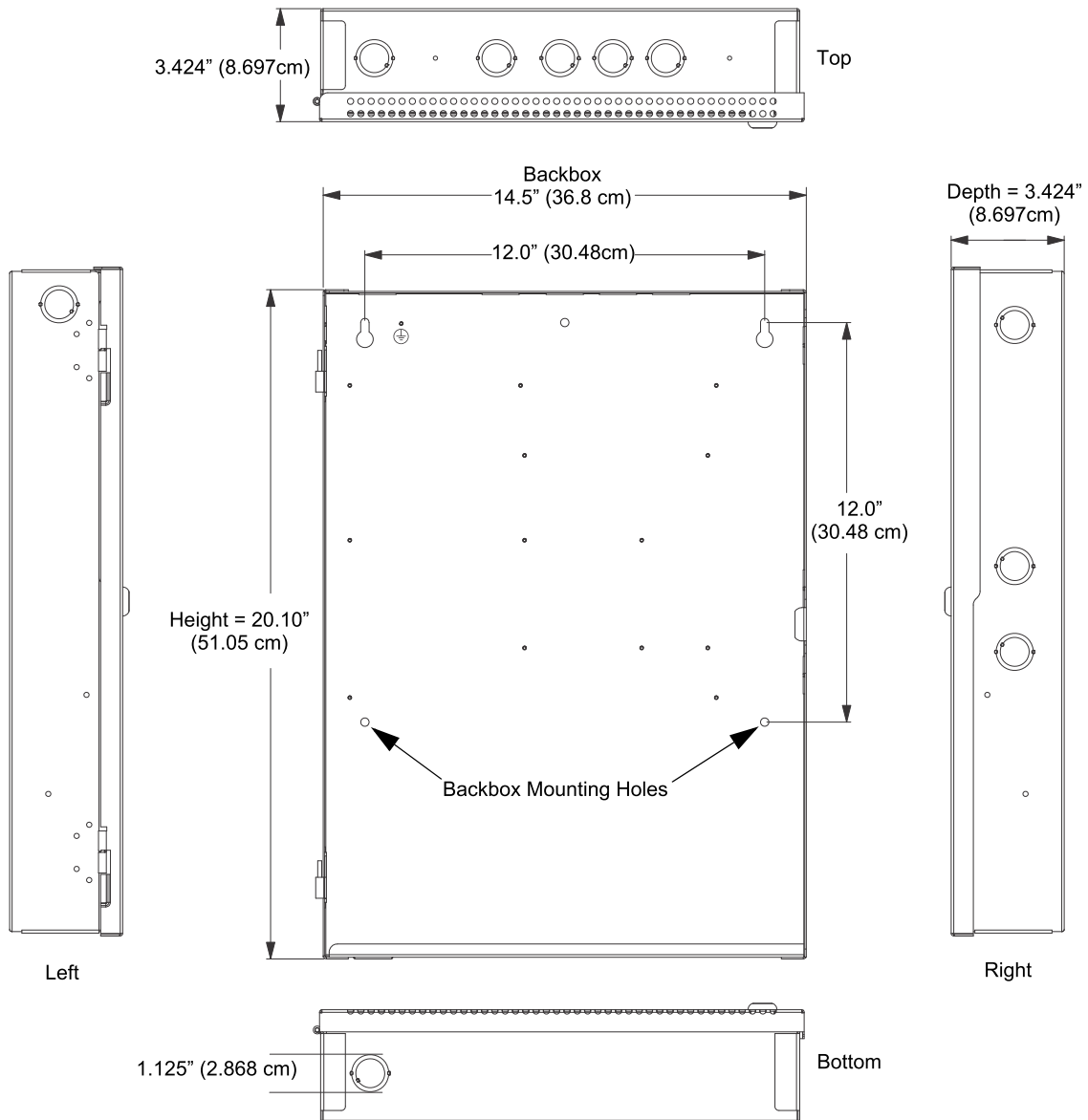

Figure 2.1 Backbox Mounting Dimensions

2.2 NAC Circuit Wiring

2.2.1 Class B

The standard configuration for NACs is Class B as shown below. Use Listed ELRs supplied by the FACP or compatible equipment manufacturer.

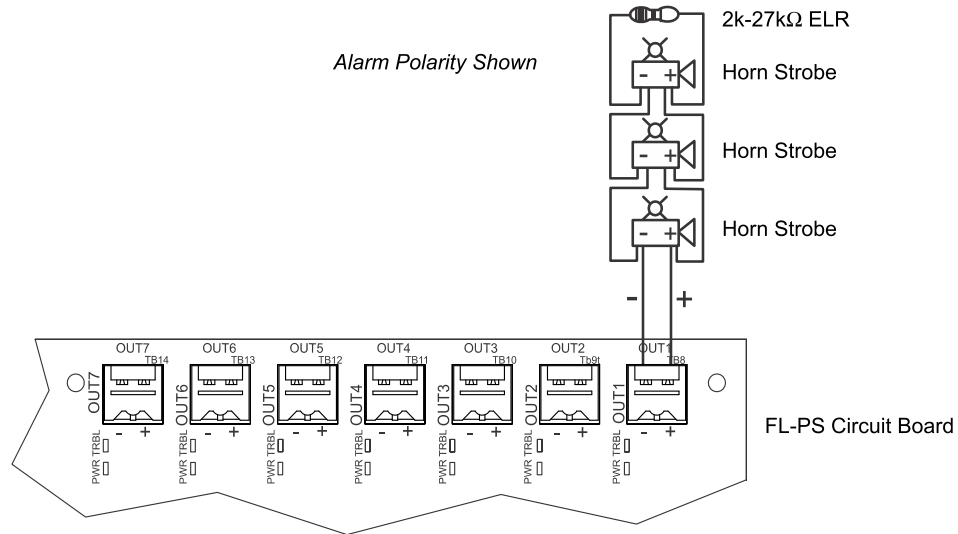

Figure 2.2 NAC Class B

2.2.2 ZNAC-PS Class A Option Module

The ZNAC-PS is an optional Class A conversion module which mounts to connector J8 on the upper right side of the circuit board. This module allows the FL-PS6 or FL-PS10 to support Class A Notification Appliance Circuits on all outputs. Class A power supervision is also supported on output circuits #1 and #2 when either of these outputs are configured as resettable or non-resettable Auxiliary power.

Two slide switches are located on the right side of the ZNAC-PS module to properly configure output circuits #1 and #2 for either NAC or Auxiliary Power operation, as described below. Note that there are no slide switches for the remaining outputs as these outputs do not support Class A power supervision.

- For output #1, set the upper switch to either “NAC1” or “AUX1” depending on the intended operation.
- For output #2, set the lower switch to either “NAC2” or “AUX2” depending on the intended operation.



NOTE: Class A supervision and the ZNAC-PS module are not intended for use with door holder operation.

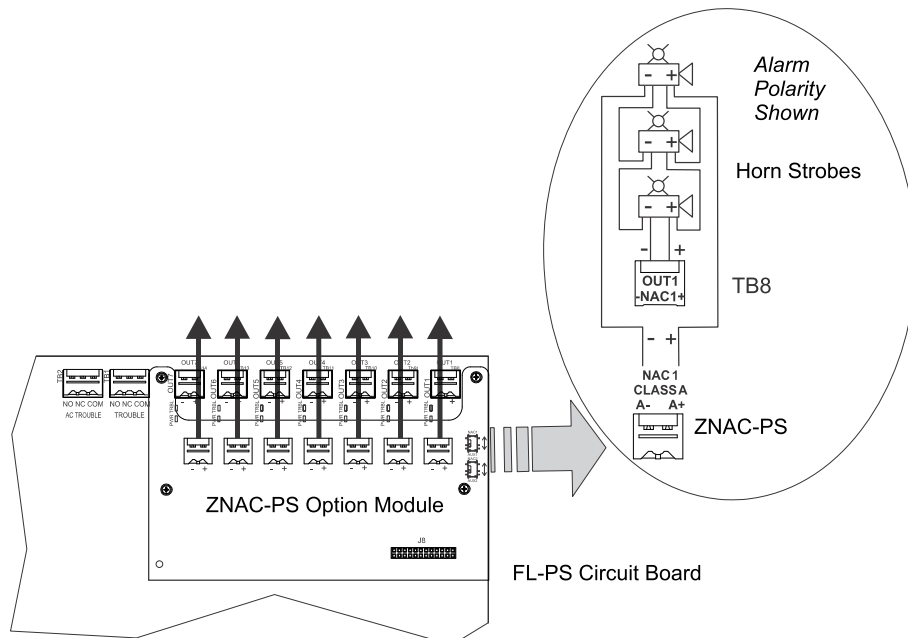

Figure 2.3 Class A NACs using ZNAC-PS Option Module

2.3 Addressable Module Mounting

The FL-PS has been designed to allow the mounting of an addressable control, relay, or monitor module on the main circuit board inside the power supply cabinet. This allows power to be fed from an FL-PS output circuit directly to the module, if needed, without running the power wires outside the cabinet. Remove mounting screws from the positions indicated below and replace with standoffs (included in hardware kit). Mount the module over the standoffs and secure with screws.

Compatible modules include the CMF-300(A), MDF-300(A), MMF-300(A), CRF-300(A), CDRM-300, CMF-300-6(A), CRF-300-6(A), and MMF-300-10(A).



NOTE: PS-MOUNT, the optional hardware kit, ordered separately, contains all necessary hardware for mounting the ZNAC-PS onto the PCB with an additional multi-point module.

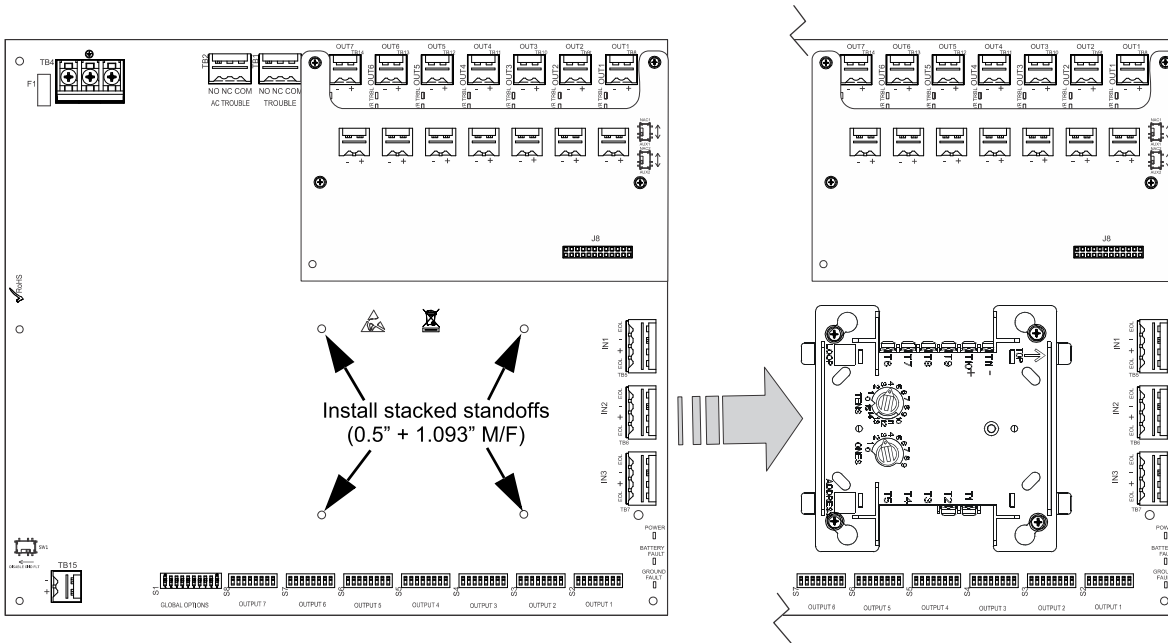
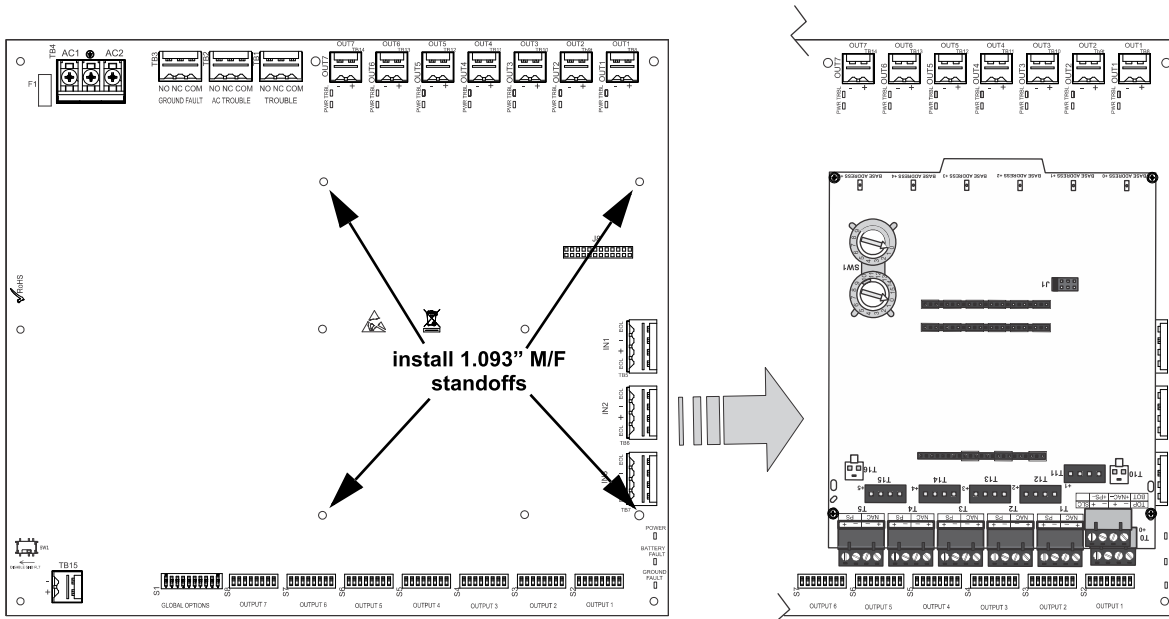

Figure 2.4 Mounting a Single Module in the FL-PS Cabinet

*If the SLC device does not match the one in this figure, refer to the SLC manual wiring conversion charts for legacy and newer versions of the modules.



Note: For instructions on mounting a multi-module and a ZNAC-PS module, refer to the ZNAC-PS Install Sheet #LS10228-000GE-E. The multi-module *must* be installed upside down when the ZNAC-PS is installed. If the ZNAC-PS is *not* installed, the multi-module may be mounted in either direction.

Figure 2.5 Mounting a Multi-Module in the FL-PS Cabinet

2.4 NEC Power-limited (Class 2) Wiring Requirements

Power-limited (Class 2) and non-power-limited circuit wiring must remain separated in the cabinet. All power-limited (Class 2) circuit wiring must remain at least 0.25" away from any non-power-limited circuit wiring and all power-limited (Class 2) circuit wiring and non-power-limited circuit wiring must enter and exit the cabinet through different conduits. One such example of this is shown below. Any conduit knockouts may be used. For power-limited (Class 2) applications, use of conduit is optional.

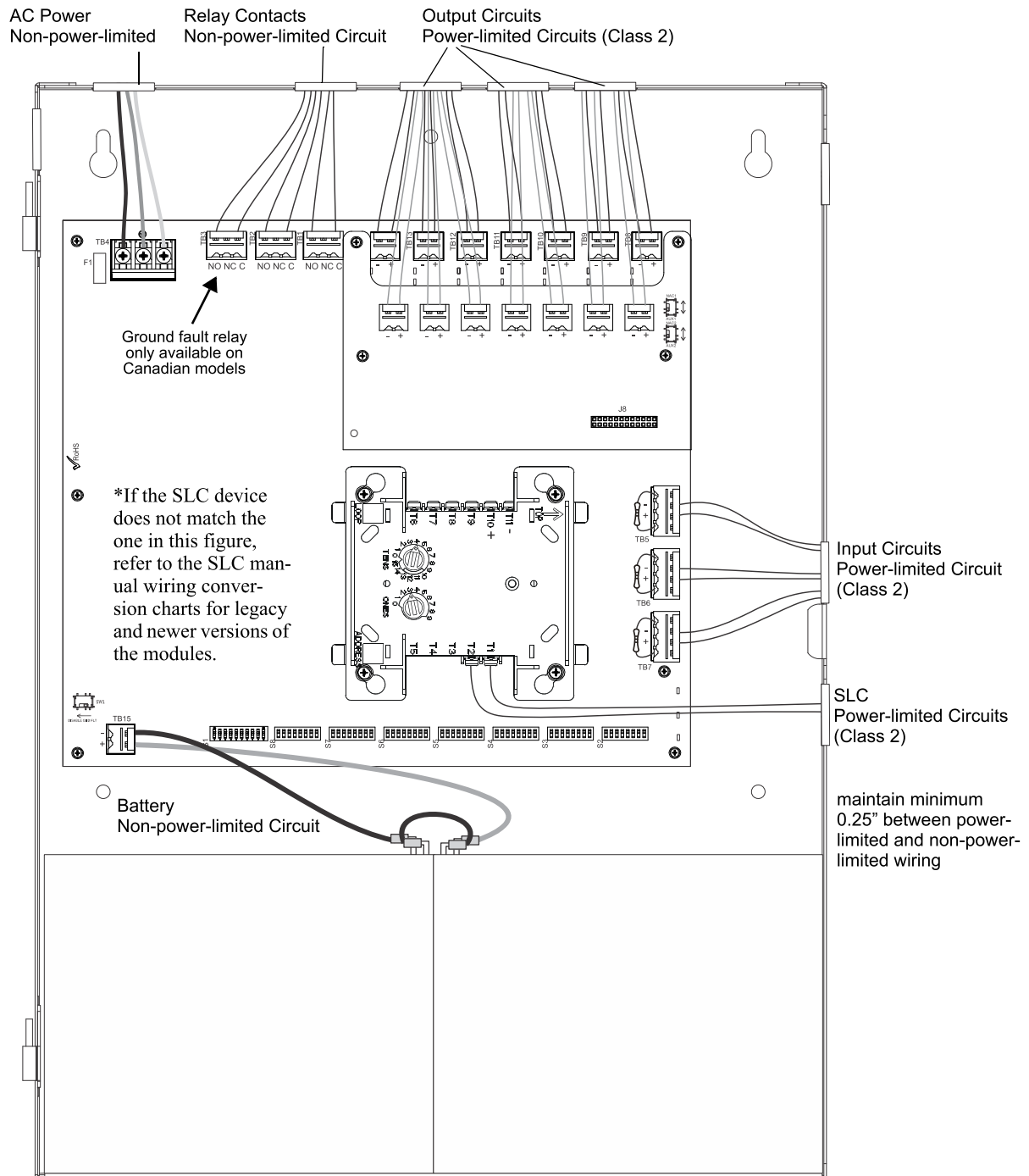

Figure 2.6 Power-limited (Class 2) Wiring Example

2.5 FACP with FL-PS Power Supply in Slave Mode

In this application, an FL-PS power supply, configured as a Slave unit, is connected to a master FACP programmed for synchronized output . .

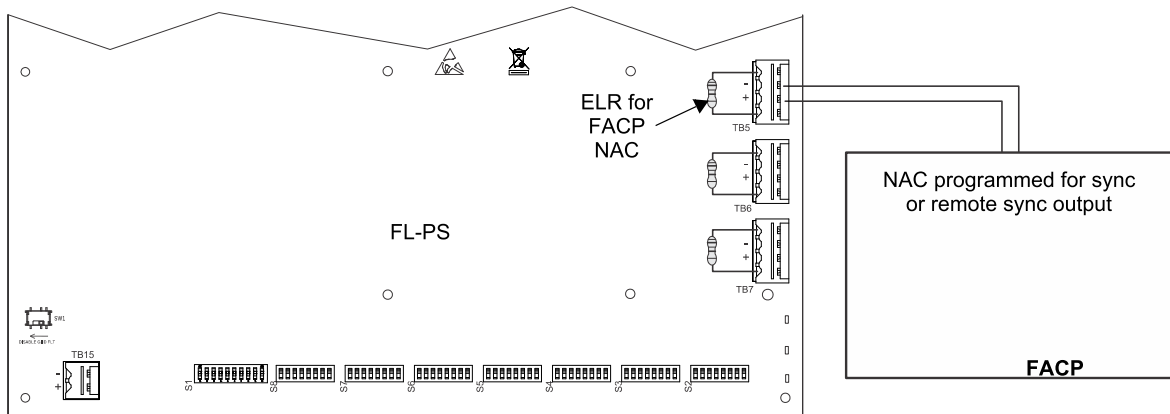

Figure 2.7 Supervised Master/Slave Connections

The following notes apply to Figure 2.7 on page 16

1. Refer to NFPA 72, Chapter 4-4, Visible Characteristics, Public Mode.
2. Use only devices from the same manufacturer in each system.
3. Set Output DIP Switch: position 3=ON, 4 = OFF, 5 = ON, 6 = OFF.
4. If the FACP has a dedicated sync output connector, wire the remote sync output connector to Input #1 terminals 2 and 3.
5. Input#1 is mapped to Slave mode output in this example, but it can be programmed to another input using the DIP switches.
6. Notification appliances cannot be installed on the FACP control circuit connecting to the FL-PS input circuits.

2.6 FL-PS Power Supply in Master Mode Connected to FACP

In this application, a master FL-PS power supply, set for synchronization, is connected to an FACP with non-synchronized output.

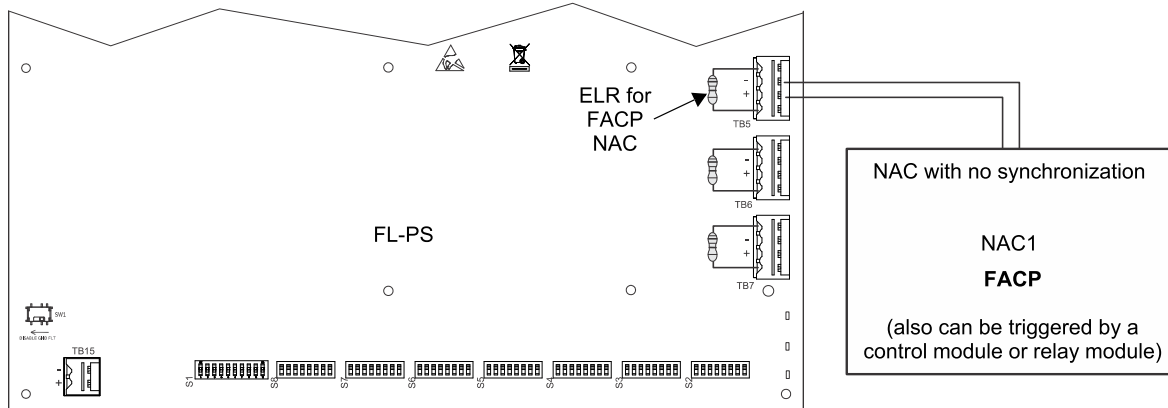

Figure 2.8 Supervised FACP to Master Connections (non-synchronized source)

The following notes apply to Figure 2.8.

1. Refer to NFPA 72, Chapter 4-4, Visible Characteristics, Public Mode.
2. Set Output DIP switches to the desired sync protocol as described below. Refer to the *Device Compatibility Document* for compatible devices.

DIP Switch Position				Synchronization Type
3	4	5	6	
ON	OFF	ON	OFF	Slave mode (NAC follower)
OFF	ON	ON	OFF	Master mode - ANSI Temporal (Temporal 3)
ON	ON	ON	OFF	Master mode - CO Temporal (Temporal 4)
OFF	OFF	OFF	ON	Master mode - Amseco/Potter
OFF	ON	OFF	ON	Master mode - Gentex
OFF	OFF	ON	ON	Master mode - System Sensor
OFF	ON	ON	ON	Master mode - Wheelock
ON	OFF	OFF	ON	Master mode, Selective Silence - Amseco/Potter
ON	ON	OFF	ON	Master mode, Selective Silence - Gentex

ON	OFF	ON	ON	Master mode, Selective Silence - System Sensor
ON	ON	ON	ON	Master mode, Selective Silence - Wheelock

- Use only devices from the same manufacturer in each zone or field of view.
- Input#1 is mapped to Master mode output in this example, but it can be programmed to another input using the DIP switches.
- Notification appliances cannot be installed on the FACP control circuit connecting to the FL-PS input circuits.

2.7 Connecting to an External Charger

The FL-PS Power Supply can be connected to an external charger to charge systems requiring over 33AH batteries. Ensure all power has been disconnected before wiring. Observe polarity when making connections. Wiring must be in conduit within 20 feet (6.096m) in the same room.

2.7.1 CHG-120F

- Set S1 position 4 on the FL-PS Power Supply to the OFF position to disable the onboard battery charger.
- Connect the battery cables between TB15 (+ and -) on the FL-PS and the CHG-120F charger output circuit (TB2: Out 1+ and Out 1-) as shown in Figure 2.9. Be certain to observe polarity.
- Connect the batteries to the charger.
- Connect the battery interconnect cable only after AC power is applied and batteries are connected. Refer to the *CHG-120F Manual* for more information.

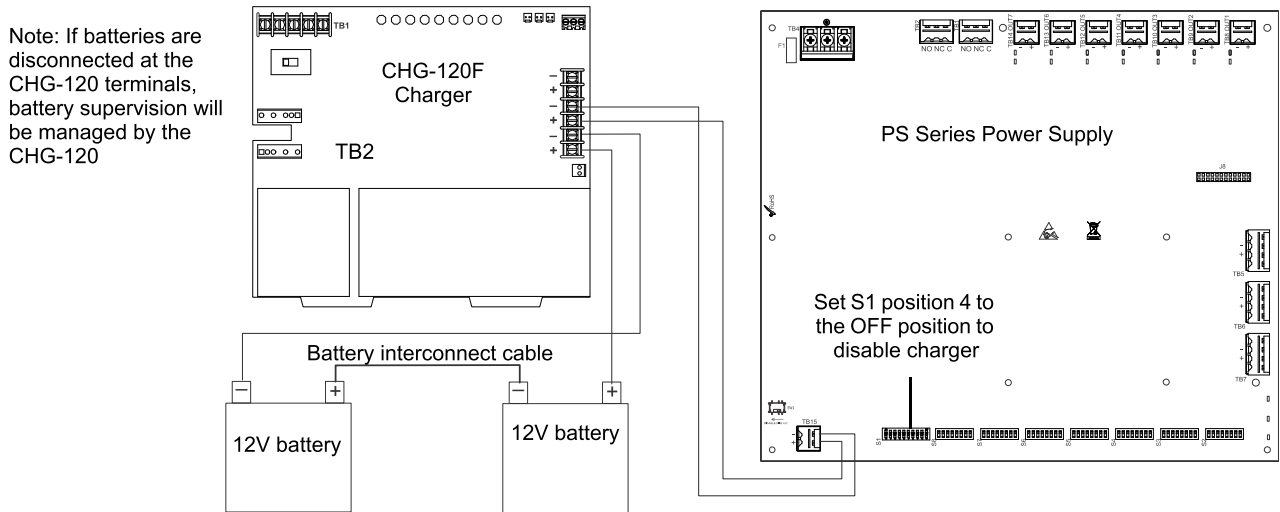

Figure 2.9 Connecting the Power Supply to a CHG-120F Charger

2.7.2 CHG-75

- Set S1 position 4 on the FL-PS Power Supply to the OFF position to disable the onboard battery charger.
- Connect the battery cables between TB15 (+ and -) on the FL-PS and the CHG-75 charger output circuit (TB2: Out+ and Out-) as shown in Figure 2.10. Be certain to observe polarity.
- Connect the batteries to the charger.
- Connect the battery interconnect cable only after AC power is applied and batteries are connected. Refer to the *CHG-75 Manual* for more information.

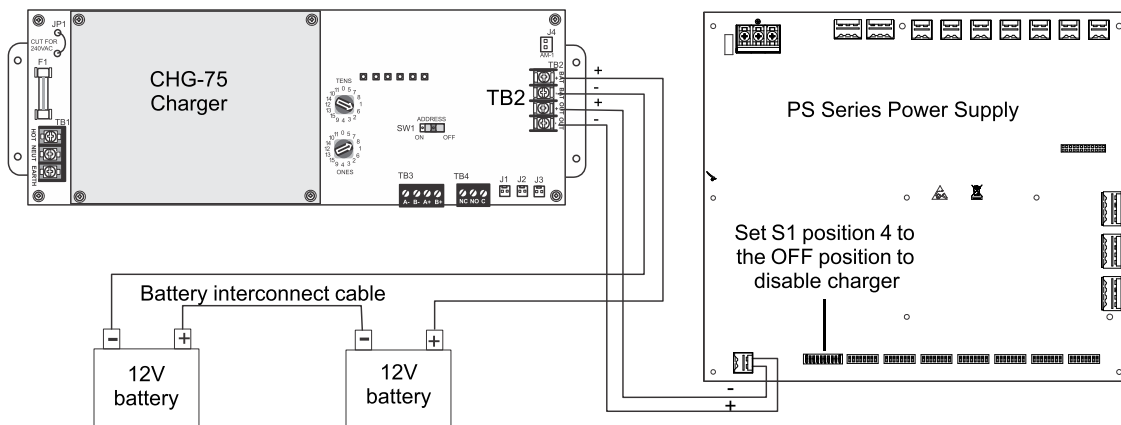

Figure 2.10 Connecting the Power Supply to a CHG-75 Charger

2.8 Cascading Multiple Units

Up to four FL-PS power supplies can be cascaded together to provide additional NAC extenders for a system. Maintain separation of power-limited and non-power-limited wiring as shown in Figure 2.6 on page 15.

Figures 2.11 and 2.12 show the controlling signal connected to Input 1 of FL-PS1. However, typically any available Input of FL-PS1 can be used.

Figures 2.11 and 2.12 show NAC7 of FL-PS1 - FL-PS3 as the cascading output. However, any available Output of FL-PS1 - FL-PS3 can be used.



NOTE: Any mode of operation that requires an additional control signal (i.e. a trigger signal), such as Selective Silence or Sync Mode, will affect which Inputs may be available on PSE1 for use with cascading. (Triggers signals are usually assigned to Input 2.) Refer to those sections of the manual for specifics.

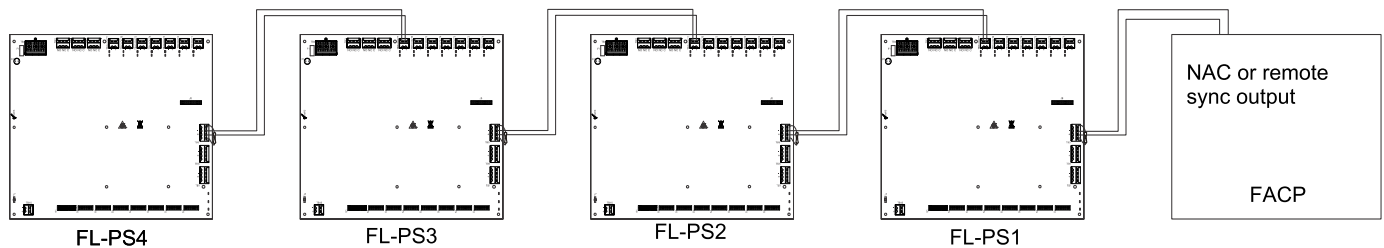

Figure 2.11 System Sync Connections Triggered by FACP

The following notes apply to Figure 2.11.

1. Set all FL-PS units to Slave (sync follower) mode.
2. The debounce/dejitter setting must be set to 1 msec on all cascaded units. See Table 3.3 on page 23.
3. Any output used for remote sync applications cannot have notification appliances installed on the same circuit.
4. Notification appliances cannot be installed on the interconnecting control circuits.
5. The total line impedance for interconnected units cannot be such that it creates a voltage drop > 3.2 VDC.
6. Ground fault supervision is provided via the general trouble relay for domestic and via the dedicated ground fault relay in the Canadian models. Enable ground fault detection on FL-PS1 and disable detection on FL-PS2-4 with negative (-) battery terminals tied together. FACP ground fault supervision will be independent of cascaded PSE1-4. (FACP negative battery terminal is not tied to PSE1).

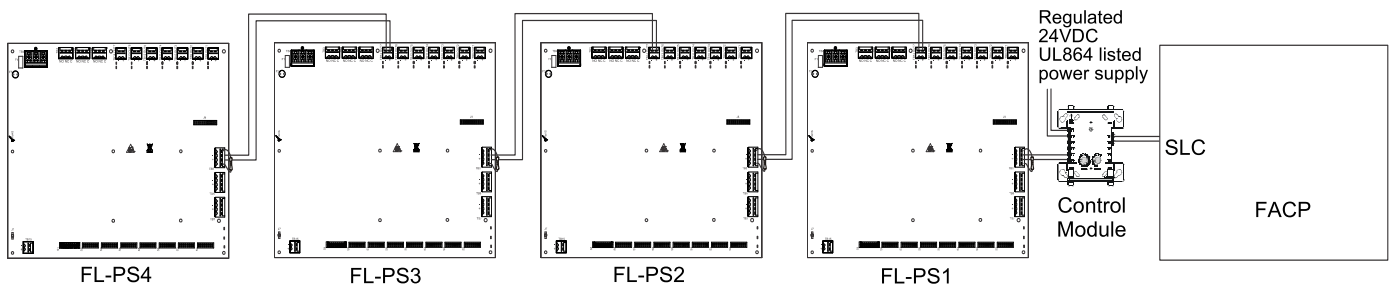

Figure 2.12 System Sync Connections Triggered by Control Module

The following notes apply to Figure 2.12.

1. Set FL-PS1 to Master Mode, and the desired strobe/horn type. Set remaining FL-PS units to Slave (sync follower) mode.
2. The debounce/dejitter setting must be set to 1 msec on FL-PS2 - FL-PS4 units. See Table 3.3 on page 23.
3. Strobe/Horn devices connected to the FL-PS units are not guaranteed to be in sync with FACP devices when using this configuration.
4. Any output used for remote sync applications cannot have notification appliances installed on the same circuit.
5. Notification appliances cannot be installed on the interconnecting control circuits.
6. The total line impedance for interconnected units cannot be such that it creates a voltage drop > 3.2 VDC.
7. Ground fault supervision is provided via the general trouble relay for domestic and via the dedicated ground fault relay in the Canadian models. Enable ground fault detection on FL-PS1 and disable detection on FL-PS2-4 with negative (-) battery terminals tied together. FACP ground fault supervision will be independent of cascaded PSE1-4. (FACP negative battery terminal is not tied to PSE1).

2.9 Canadian Applications

Installation shall be in accordance with ULC S524. Wiring methods shall be in accordance with CSA C22.1, Safety Standard for Electrical Installations, Canadian Electrical Code, Part I, Section 32.



NOTE: Mass Notification is not for use in Canadian applications.

Canadian applications, per ULC, require the following:

- Connect the AC ground wire to the Ground Stud located at the top left of the backbox as shown below. Connect the incoming earth ground wire to supplied cable #71073 with a wire nut. Position the ring terminal end over the grounding stud. Secure with one of the keps nuts. Place the ring terminal from the other supplied ground cable #71073 over the ground stud and secure with the second keps nut. Wire the ground cable to the middle position of TB4. Ensure that the ground for incoming AC mains is the first wire installed, closest to the backbox. This connection is vital in reducing the panel's susceptibility to transients generated by lightning and electrostatic discharge. Apply AC power to the panel only after the system is completely installed and visually checked. *Note that AC power must be applied to the panel before installing the battery interconnect cable.*

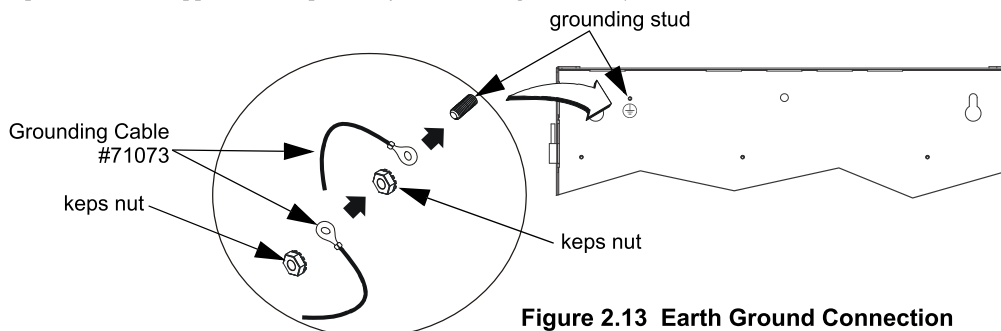

Figure 2.13 Earth Ground Connection

- Refer to Section 5.1 for instructions to meet ULC requirements for trouble monitoring of each zone.

Ground Fault Detection

When connected to an FACP, the host FACP must monitor for all ground fault conditions.

There are three ways to monitor for ground faults when cascading multiple power supply units (up to four).

- ✓ The negative (-) battery terminal of the FL-PS power supply must be connected to the negative (-) battery terminal of the host FACP. Battery wiring is non-power-limited. Power-limited and non-power-limited wiring must be wired with a minimum of 0.25" spacing in between and enter/exit through different knockouts. When cascading multiple power supply units, continue connecting the negative battery terminals, including FACP battery terminal. Ground faults must then be detected by the first FL-PS in the chain. Disable ground fault detection on other FL-PS units by sliding SW1 to the left. Ensure ground fault detection is enabled on FL-PS1, the first power supply from the FACP, by sliding SW1 to the right. 18 AWG wire minimum must be used.

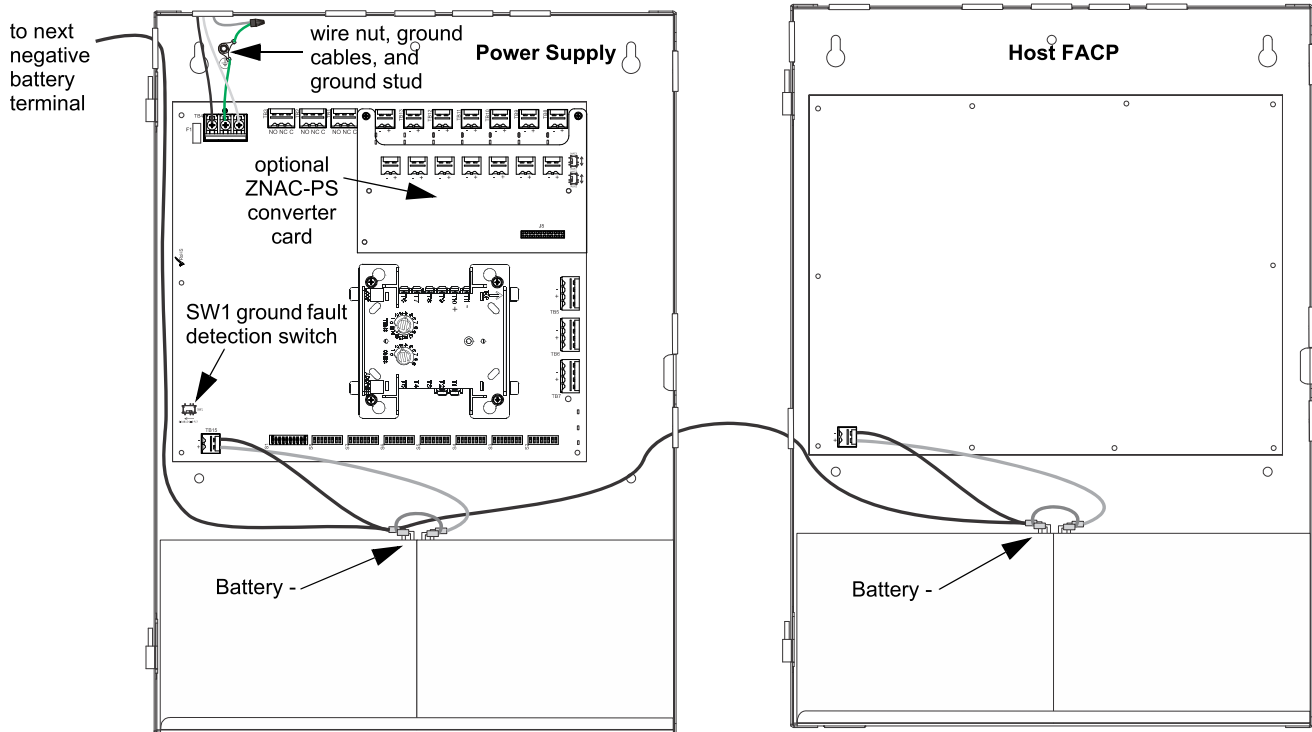

Figure 2.14 Canadian Applications Option 1

- ✓ Ground fault monitoring may be accomplished by mapping an annunciator point on a ULC S527-listed FACP as ground fault. The annunciator shall be wired adjacent to the FACP so all displays are grouped for viewing and operation by one person. Addressable FACP: The FACP must be programmed to turn on the common trouble LED, trouble tone, and a separate yellow annunciator point when the monitor module connected to the FL-PS ground fault relay is initiated. The annunciator point must also be labeled as “XXX Ground Fault” where “XXX” describes ground fault origin.

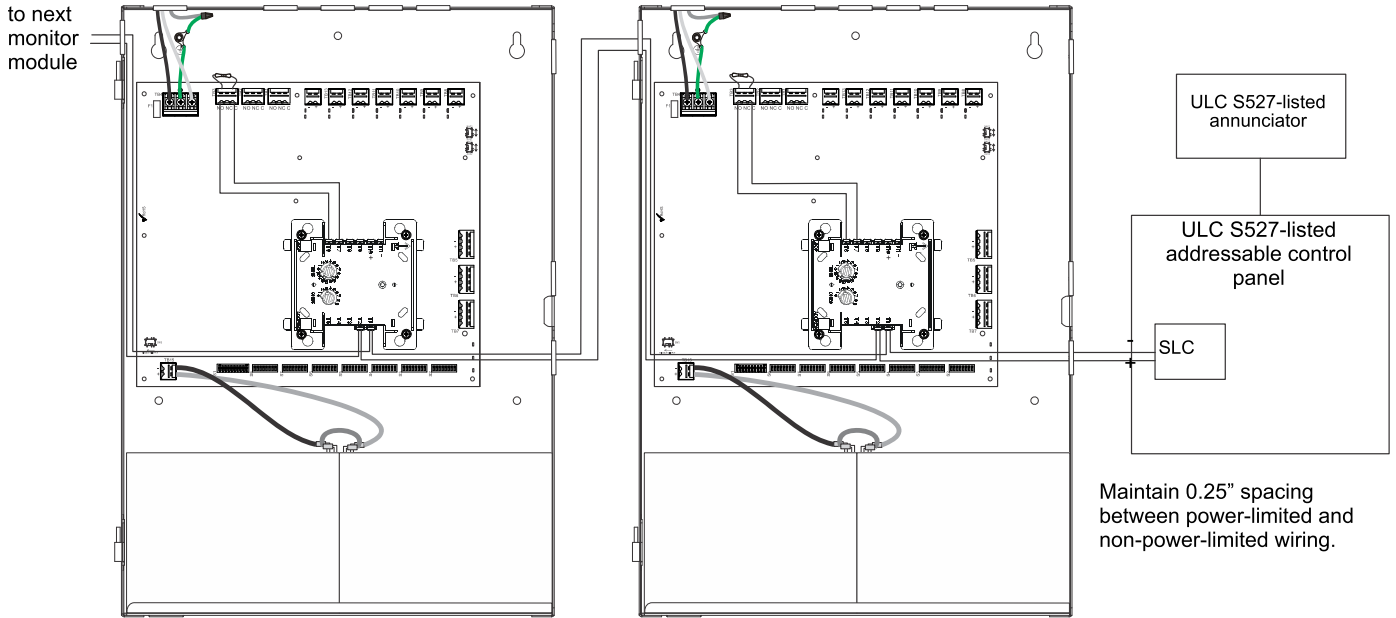

Figure 2.15 Canadian Applications Option 2 - Addressable FACP

Conventional FACP: The FACP must be programmed to turn on the common trouble LED, trouble tone, and a separate yellow annunciator point when the input connected to the FL-PS ground fault relay is initiated. Use one input per FL-PS power supply.

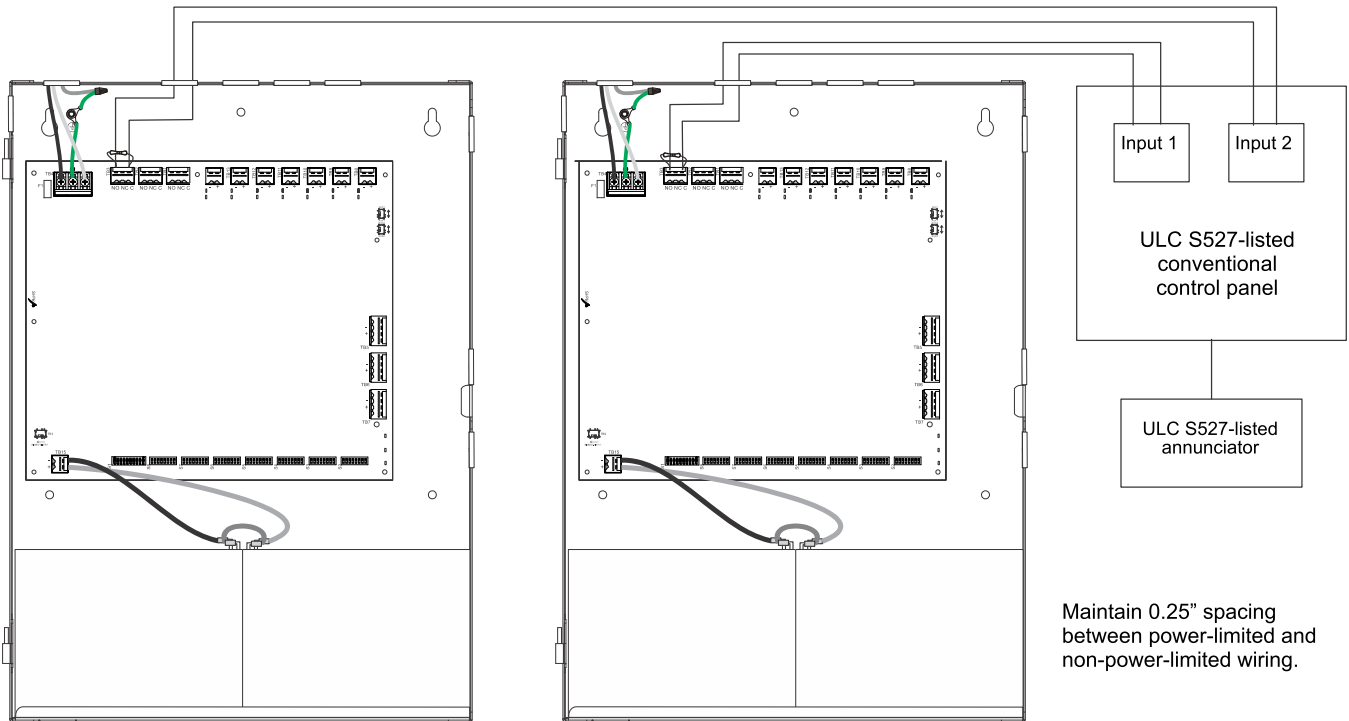

Figure 2.16 Canadian Applications Option 3 - Conventional FACP

Section 3: Programming Options

NOTICE TO USERS, INSTALLERS, AUTHORITIES HAVING JURISDICTION AND OTHER INVOLVED PARTIES				
This product incorporates field-programmable software. In order for the product to comply with the requirements in the Standard for Control Units and Accessories for Fire Alarm Systems, UL 864, certain programming features or options must be limited to specific values or not used at all as indicated below:				
Program feature or option	Permitted in UL864/2572 and ULC S527? (Y/N)	Possible settings	Settings permitted in UL 864 / UL2572	Settings permitted in ULC S527
Door Holder Dropout Delay	Y	Refer to "AC Loss Door Holder Dropout Timer" on page 24. <ul style="list-style-type: none"> • Does not drop • 15 seconds • 5 minutes • 60 seconds 	<ul style="list-style-type: none"> • Does not drop • 15 seconds • 60 seconds • 5 minutes 	<ul style="list-style-type: none"> • Does not drop • 15 seconds • 60 seconds • 5 minutes
AC Loss Delay Timer	Y	Refer to "AC Fail Indication Delay" on page 24. <ul style="list-style-type: none"> • 30 hours • 12 hours • 2 hours • none 	<ul style="list-style-type: none"> • 2 hours¹ • none 	<ul style="list-style-type: none"> • 2 hours • none

Table 3.1 Agency-Permitted Programming Settings

1 A two hour delay is only permitted on an addressable FACP.

This section describes the programming options available via DIP switch settings. The FL-PS can be field programmed using DIP switches S1-S8 which are located at the bottom of the circuit board. S1 controls the global options of the power supply and S2-S8 control the functions of each output circuit, respectively. Refer to the following illustration for switch locations and DIP switch placement in the ON and OFF positions.

Important: Activate output DIP switch changes by setting S1 positions 9 and 10 appropriately. Refer to Table 3.6 on page 24 for DIP Switch programming settings.

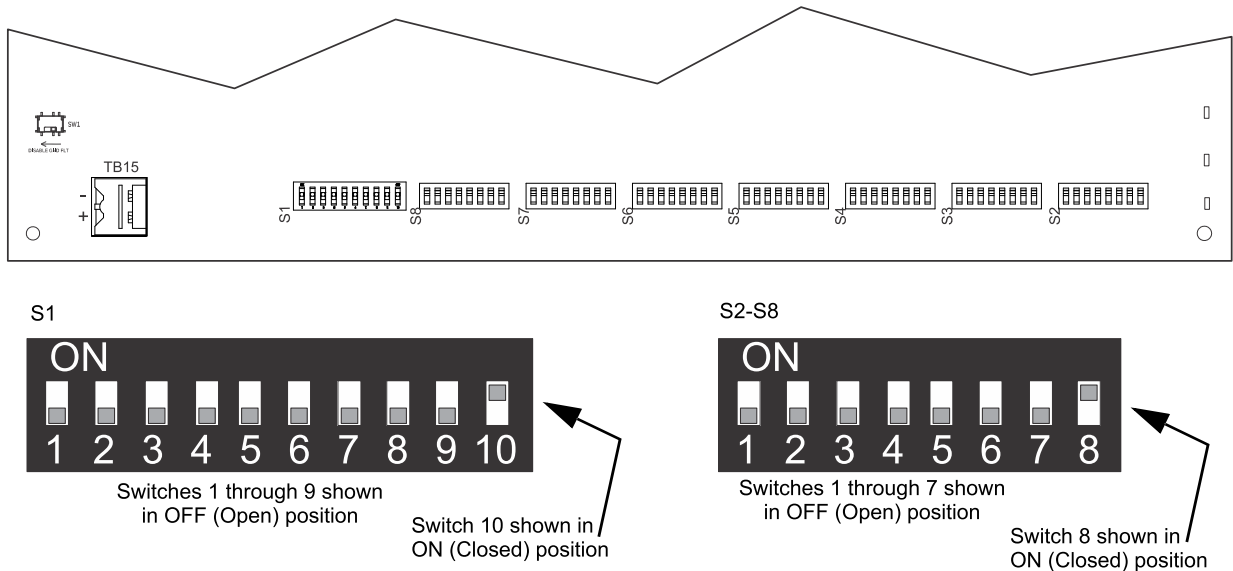

Figure 3.1 Field Programming DIP Switches

3.1 S1 Global Options DIP Switch

The following table lists the global control options for the FL-PS programmable features and the switch settings required to select a particular feature. A detailed description of each feature is presented in the following pages. Refer to Table 3.1 for UL-compliant settings.

S1 DIP Switch	OFF	ON
1, 2	These switches determine the command input debounce/dejitter setting (Setting applies to ALL inputs) ¹ . 1 OFF, 2 OFF = Temporal (for ANSI temporal signals) 1 ON, 2 OFF = 50Hz (20 msec, for full wave rectified signals) 1 OFF, 2 ON = 6 msec (for strobe sync signals, control/relay modules) 1 ON, 2 ON = 1 msec (for strobe sync signals, control/relay modules)	
3	Command Input #1 configured for Slave Mode Sync ² input ³	Command Input #1 configured as normal
4	Internal battery charger = disabled	Internal battery charger = enabled
5, 6	These switches determine door holder dropout delay after AC power loss 5 OFF, 6 OFF = Power does not drop out 5 ON, 6 OFF = 5 minutes 5 OFF, 6 ON = 60 seconds 5 ON, 6 ON = 15 seconds	
7, 8	These switches determine the AC loss delay timer 7 OFF, 8 OFF = 30 hours 7 ON, 8 OFF = 12 hours 7 OFF, 8 ON = 2 hours 7 ON, 8 ON = none	
9, 10	These switches determine the operating mode of the power supply. <i>Return switches to normal mode to exit change output circuit configurations and display trouble history modes!</i> 9 OFF, 10 OFF = normal 9 ON, 10 OFF = change output circuit configurations 9 OFF, 10 ON = display trouble history 9 ON, 10 ON = normal	

Table 3.2 S1 Global Options DIP Switch Settings

- 1 Debounce/dejitter provides settling time for input signals to avoid false triggers.
- 2 Strobe synchronization only works with non-coded NACs.
- 3 Output circuit(s) must be set to activate on Input #2. See, "Command Input #1" below.

3.1.1 Global Programmable Features Description

Input Debounce/Dejitter/Delay

Signals from electronic circuits or relay contacts can have a small unstable time when changing state (OFF to ON, or ON to OFF). This means the signal can briefly “bounce” between states before stabilizing to the desired state, causing signal “jitter” during this time. The FL-PS provides four “debounce/dejitter” settings, as shown in the table below. These settings provide time for a NAC Input signal to stabilize before that NAC Input will recognize it as a valid signal, and not just “noise”, so as to prevent false activation of Output circuits. Input debounce settings can be used as needed.

Unless the system experiences input “noise” issues, apply 1ms setting for general use.

Position 1	Position 2	Setting	Notes
OFF	OFF	Temporal	Debounces ANSI temporal signals. Allows for a 0.5 second ON signal with an almost 2 second OFF signal to trigger a continuous ON input signal. <i>Do not use for strobe sync signals.</i>
ON	OFF	50Hz (20msec)	Debounces FWR (full wave rectified signals). Allows an input signal with 50Hz, 33% duty cycle to trigger a continuous (i.e. filters FWR input signal to appear constantly on) ON input signal. May apply to legacy panels. <i>Do not use for strobe sync signals.</i>
OFF	ON	6 msec	Input delay for strobe sync signals (i.e. Slave mode using sync input), or control/relay modules (i.e. Master or Aux. power mode using trigger input).
ON	ON	1 msec	Input delay for strobe sync signals (i.e. Slave mode using sync input), or control/relay modules (i.e. Master or Aux. power mode using trigger input). Must be the only one used when cascading Power Strike units. Refer to Section 2.8, “Cascading Multiple Units”, on page 18.

Table 3.3 Debounce/Dejitter Settings

Command Input #1

Power supply Output circuits can be configured to “follow” a sync pattern that is input to Command Input #1 (TB5), either immediately (Normal Mode), or only after a trigger signal (Sync Input Mode) is applied at Command Input #2 (TB6). In Sync Input Mode an output circuit will only output the Command Input #1 sync pattern when Command Input #2 is receiving a valid (9V - 32V) trigger signal.

See “Command Input #1 - Normal/Sync Mode of Operation” on page 27 for additional information.

Charger Enable/Disable

The FL-PS battery charger can be disabled to accommodate an external battery charger, such as the CHG-75 or CHG-120F. Setting DIP switch position 4 to the OFF position will disable the charger. Setting DIP switch position 4 to the ON position will enable the charger. It should only be disabled if an external battery charger is being used for the FL-PS.

AC Loss Door Holder Dropout Timer

Any output can be configured as a NAC, aux power, or door closer circuit. Configuring an output circuit as a door closer circuit will provide a steady 24 VDC to door holders until an alarm condition or an AC fail condition. Upon an alarm condition, power to door holder circuits will be removed, causing doors to close immediately. During an AC fail condition, the door holder will remain energized until the programmed AC fail indication delay expires. Programmed delays are only applicable to AC loss conditions. Refer to Table 3.1 for UL-compliant settings.

DIP switch positions 5 and 6 are used to select the door holder dropout timer as listed below:

Position 5	Position 6	Door holder dropout delay after AC loss
OFF	OFF	Power does not drop out with AC loss
ON	OFF	5 minutes
OFF	ON	60 seconds
ON	ON	15 seconds

Table 3.4 Door Holder Dropout Settings

AC Fail Indication Delay

The AC Fail Indication Delay feature provides the option to delay generation of a trouble signal upon the loss of AC power. Refer to Table 3.1 for UL-compliant settings.

DIP switch positions 7 and 8 are used to select the AC Fail Indication Delay as listed below:

Position 7	Position 8	AC Fail Indication Delay
OFF	OFF	30 hours
ON	OFF	12 hours
OFF	ON	2 hours
ON	ON	none

Table 3.5 AC Loss Delay Settings

Refer to “AC Trouble Relay” on page 31, for operation of internal NAC trouble relay in response to AC loss.

Special Operating Modes

The power supply can be placed in two special operating modes per settings in Table 3.6. They are Change Output Circuit Configurations and Display Trouble History. *Upon completion of either of these two modes, the system must be placed back in normal operating mode. Note that the current operation of all outputs will not be affected or disturbed while in either of these two special operating modes.*

Change Output Circuit Configurations mode:



NOTE: DIP switch settings may be changed to the desired configuration either before or after entering Change Output Circuit Configurations mode.

1. Enter this mode via the setting shown in Table 3.6. Once entered, the Output trouble LEDs will continually flash from right to left to confirm the FL-PS is in Change Output Configuration mode.
2. Configure settings on the Output DIP switches as needed (see Note above).
3. Return to Normal Operating mode via either of the two settings shown in Table 3.6. The output trouble LEDs will stop the flash pattern described above to confirm Normal mode has been restored.

The FL-PS power supply offers a trouble history mode. To see past troubles on the system, place position 9 to OFF and position 10 to ON. Refer to Section 4 for descriptions of troubles. Trouble history will be erased upon returning to Normal operating mode.

DIP switch positions 9 and 10 are used to select the type of operating mode as listed below:

Position 9	Position 10	Operating Mode
OFF	OFF	Normal
ON	OFF	Change output circuit configurations

Table 3.6 Operating Mode

OFF	ON	Display Trouble History
ON	ON	Normal

Table 3.6 Operating Mode

3.2 Output Circuit Control DIP Switch Settings

Each output circuit has its own programming DIP switch. DIP switches S2-S8 are labeled on the PCB to indicate which output circuit it is controlling. Output circuits are labeled at the top of the PCB, TB8-TB14. The following table applies to DIP Switches S2-S8.

Important! If an output circuit is overloaded, the output will shut off and generate a trouble signal. If this happens, the FL-PS will need to be reset manually. Either reset circuit configurations by toggling switch S1 position 10 to the OFF position for a minimum of five seconds or turn off primary and secondary power and reapply to the FL-PS.

DIP Switch Position				Output Control Setting/Operation
	1	2		
	OFF	OFF		NAC output will activate when Command Input #1 is activated.
	ON	OFF		NAC output will activate when Command Input #2 is activated. (Exception: this Input controls Horn silencing during Selective Silence operation.)
	OFF	ON		NAC output will activate when Command Input #3 is activated, if available. (If accidentally programmed on a FL-PS6, the system will default to Input #2.)
	ON	ON		NAC output will activate when ANY Command Input is activated.
3	4	5	6	Output Control Setting/Operation
OFF	OFF	OFF	OFF	Unused/Unsupervised. Outputs will not activate. <i>Factory default setting.</i>
ON	OFF	OFF	OFF	Reserved- Outputs will not activate
OFF	ON	OFF	OFF	Non-resettable auxiliary power
OFF	OFF	ON	OFF	Resettable aux power
ON	ON	OFF	OFF	Door holder auxiliary power
ON	OFF	ON	OFF	Slave mode (NAC follower)
OFF	ON	ON	OFF	Master mode - ANSI Temporal (Temporal 3)
ON	ON	ON	OFF	Master mode - CO Temporal (Temporal 4)
OFF	OFF	OFF	ON	Master mode - Amseco/Potter
OFF	ON	OFF	ON	Master mode - Gentex
OFF	OFF	ON	ON	Master mode - System Sensor
OFF	ON	ON	ON	Master mode - Wheelock
ON	OFF	OFF	ON	Master mode, Selective Silence - Amseco/Potter
ON	ON	OFF	ON	Master mode, Selective Silence - Gentex
ON	OFF	ON	ON	Master mode, Selective Silence - System Sensor
ON	ON	ON	ON	Master mode, Selective Silence - Wheelock
			7	Output Control Setting/Operation (Only applies when ZNAC-PS is installed)
			OFF	Class B
			ON	Class A
			8	Output Control Setting/Operation (Unused)
			OFF	Unused/Unassigned
			ON	Unused/Unassigned

Table 3.7 S2-S8 Output Circuit DIP Switch Settings

3.2.1 Output Circuit Programmable Features Description

Command Inputs/NAC Circuits

The FL-PS allows for individual NAC circuit programming. Each NAC can be configured to activate based on the settings selected for up to 3 command inputs.

Position 1	Position 2	Output to Command Input Assignment
OFF	OFF	NAC will activate when Input #1 activates.
ON	OFF	NAC will activate when input #2 activates. (Exception: this Input controls Horn silencing during Selective Silence operation.)

Table 3.8 NAC Activation Settings

OFF	ON	NAC will activate when input #3 activates. (Input #3 is only available on the FL-PS10 model. If selected on FL-PS6, this setting will default to input #2.)
ON	ON	NAC will activate when any input (1, 2, or 3) activates.

Table 3.8 NAC Activation Settings

Unused Outputs

The factory default setting for all output circuits is “unused/unsupervised” where positions 3, 4, 5, and 6 are set to the OFF position. Any unused or disabled outputs in the system configuration must be set to OFF as shown below.

Position 3	Position 4	Position 5	Position 6	Auxiliary Power Type
OFF	OFF	OFF	OFF	Unused/Unsupervised. Outputs will not activate. <i>Factory default setting.</i>
ON	OFF	OFF	OFF	Reserved- Outputs will not activate

Table 3.9 Auxiliary Power Settings

Remote Supply with Resettable and Non-resettable Power

Each output circuit on the FL-PS can be used as a remote stand-alone power supply to provide power to any devices that require filtered, resettable or non-resettable power. The FL-PS can provide up to 3 amps of continuous current. Non-resettable power is suitable for powering annunciators and other peripheral equipment. Resettable power is suitable for four-wire smoke detectors. Resettable outputs reset when the mapped input receives a negative pulse trigger signal from FACP or control module. There will be a three second delay prior to output reset. The output reset will last 10 seconds. Set DIP switches positions indicated in Table 3.10 below to select auxiliary power type.

Position 3	Position 4	Position 5	Position 6	Auxiliary Power Type
OFF	ON	OFF	OFF	Non-resettable (constant) aux power
OFF	OFF	ON	OFF	Resettable aux power

Table 3.10 Auxiliary Power Settings

Door Holder

Each output circuit can be configured as a door holder circuit. Setting DIP switch positions according to Table 3.11 will configure the selected output circuit as a door holder circuit which will provide a steady 24 VDC to door holders until a mapped input activates an alarm or when an AC fail condition removes the power following a programmable delay. See “AC Loss Door Holder Dropout Timer” on page 24 for more information.

Position 3	Position 4	Position 5	Position 6	Door Holder
ON	ON	OFF	OFF	Set as door holder circuit

Table 3.11 Door Holder Power

Synchronization Mode - Master/Slave

The FL-PS power supply can be configured for Master or Slave Synchronization by setting DIP switches according to Table 3.12. Synchronization is a feature that controls the activation of notification appliances in such a way that all devices will turn on and off at exactly the same time. This is particularly critical when activating strobes which must be synchronized to avoid random activation and a potential hazard or confusion.

In some installations, it is necessary to synchronize the flash timing of all strobes in the system for ADA compliance. Strobes accomplish this by monitoring very short timing pulses on the NAC power which are created by an FACP with synchronization capability. When installed at the end of a NAC wire run, this power supply can track (follow) the strobe synchronization timing pulses on the existing NAC wire run. This maintains the overall system flash timing of the additional strobes attached to this power supply. Note that strobe synchronization works only with non-coded NACs.

When the output circuit is configured as a *sync generator* (Master Synchronization mode), the sync input circuit will only be used to trigger the output. The power supply is the originator of the strobe synchronization pulse on the NAC output. Refer to Table 3.12 to select the desired Master mode sync type.

When the output circuit is configured as a *sync follower* (Slave Synchronization mode), the power supply’s NAC outputs track the strobe synchronization pulses present at the supply’s Input terminals (based on the settings selected from Table 3.8). The pulses originate from an upstream FACP or other power supply. Some FACPs provide synchronization timing pulses from a dedicated sync output connector. Connect the FL-PS input terminals to the FACP sync output connector instead of the FACP NAC.

If circuits are configured for both master and slave mode, devices must be installed in different zones or field of view on a circuit basis.

Position 3	Position 4	Position 5	Position 6	Synchronization Type
ON	OFF	ON	OFF	Slave mode (NAC follower) - NAC outputs track Command Input Circuits
OFF	ON	ON	OFF	Master mode - ANSI Temporal (Temporal 3)

Table 3.12 Sync Mode - Master/Slave Settings

ON	ON	ON	OFF	Master mode - CO Temporal (Temporal 4)
OFF	OFF	OFF	ON	Master mode - Amseco/Potter
OFF	ON	OFF	ON	Master mode - Gentex
OFF	OFF	ON	ON	Master mode - System Sensor
OFF	ON	ON	ON	Master mode - Wheelock

Table 3.12 Sync Mode - Master/Slave Settings

Master Mode - Selective Silence

Selective Silence allows the silencing of the sounder portion of a horn/strobe combination device without turning off the strobe. Selective Silence is only supported while in Master mode setting for Amseco, Gentex, System Sensor, and Wheelock. Refer to Table 3.13 to select the desired Master mode, Selective Silence sync type.



NOTE: Do not apply synchronization signals to Command Input #1 and 2. Only trigger signals are allowed (i.e. constant 9-32 VDC). Synchronization signal is internally generated by the system when in Master mode.

Only Command Inputs #1 and #2 are used to control the Selective Silence operation. (Command Input #3 on FL-PS10 does not support Selective Silence.) Input #1 is for activating the horn/strobe devices, while Input 2 only controls sounding of the horns. Input #1 must be active for Input #2 to have any effect on NAC outputs set for Selective Silence. The list below provides additional detail.

- If only Command Input #1 is active, only the strobes will be activated.
- If both Command Input #1 and #2 are active, strobes and horns will be activated.
- If only Command Input #2 is active, NAC outputs will not be activated.
- If neither Command Input #1 nor #2 is active, NAC outputs will not be activated.

Position 3	Position 4	Position 5	Position 6	Synchronization Type
ON	OFF	OFF	ON	Master mode, Selective Silence - Amseco/Potter
ON	ON	OFF	ON	Master mode, Selective Silence - Gentex
ON	OFF	ON	ON	Master mode, Selective Silence - System Sensor
ON	ON	ON	ON	Master mode, Selective Silence - Wheelock

Table 3.13 Master Mode - Selective Silence Settings

Command Input #1 - Normal/Sync Mode of Operation

For Normal Mode of operation, see previous section.

Sync Mode is an available option for the Slave Synchronization operating mode (see previous section). Sync Mode differs from the Slave Synchronization Normal Mode of operation because it requires an additional “trigger” signal to activate the output(s). Once the trigger signal is active, the corresponding output(s), as selected by the Output DIP Switch settings, will follow any synchronization signal provided to Input #1.

- Input #1 is dedicated as the follower input for any synchronization signal received into this input. Do not apply the trigger signal to this input.
- Input #2 is used for the trigger input for either the 6 amp or 10 amp models. Do not apply the synchronization signal to this input.
- Input #3 can also be used for the trigger input, but is only available on the 10 amp model. Do not apply the synchronization signal to this input.
- Use only one input (Input #2 or #3) at any one time for the trigger input.
- A trigger signal between 9-32VDC is required for proper operation.
- Set the Global DIP switch, S1 position 3, to the OFF position. See below:



NOTE: If Input #1 signal is lost while Input #2 (or Input #3, if available) trigger is active, output circuits will deactivate.

S1 DIP Switch	OFF	ON
3	Command Input #1 configured for Sync input	Command Input #1 configured as normal

Set DIP switch positions 1 and 2 according to which input circuit, #2 or #3, is used as the trigger input as shown below.

Position 1	Position 2	Trigger Input Assignment For Sync Mode Operation
ON	OFF	NAC will activate when Input #2 activates
OFF	ON	NAC will activate when Input #3 activates (Input #3 is only available on the FL-PS10 model. If selected on FL-PS6, this setting will default to input #2.)

DIP switch positions 4, 5, and 6 should be set to Slave Mode as shown below:

Position 3	Position 4	Position 5	Position 6	Synchronization Type for Sync Mode Operation
ON	OFF	ON	OFF	Slave mode (NAC follower) - NAC outputs track Command Input Circuits

Table 3.14 Sync Mode Settings

Class A Wiring

NAC circuits (all outputs) and aux power circuits (outputs 1 and 2) can be converted to Class A wiring using the ZNAC-PS option card. Setting DIP switch position 7=ON when a selected output circuit is configured for Class A wiring. The default setting is OFF for Class B wiring.

■ Maximum Number of Strokes for Synchronization

The total current draw for each Notification Appliance Circuit cannot exceed 3.0 amps special application, 1A (6 amp model) or 1.5A (10 amp model) regulated. Refer to the manufacturer's documentation supplied with the strobe to determine the maximum current draw for each strobe and ensure that the circuit maximum is not exceeded.

To ensure proper strobe and circuit operation, there is also a limit to the number of strobes that can be attached to each circuit. Following is a table of the strobes that have been tested with the power supply and the maximum number that can be connected to each NAC when using the lowest candela settings. *Make sure that the NAC maximum current is not exceeded:*

Manufacturer	max. number of strokes ¹
System Sensor	69
Gentex	42
Wheelock	50
Amseco/Potter	34



Table 3.15 Maximum Number of Strokes

¹ These values are for strobe-only devices at the minimum candela setting. Values will be different for strobe/horn and horn-only devices. Refer to the manufacturer's installation documents for values on these devices.

Section 4: LED Indicators

The FL-PS power supply has 3 system LED indicators for Power, Batt/Chgr Fault, and Ground Fault. In addition, each available output circuit also has 2 status LEDs. Refer to Figure 1.1 on page 10 for LED locations. A description of each FL-PS LED indication is given below.

Ground Fault LED (yellow)

No Fault	LED is OFF 
Fault Condition: ground fault	LED is ON constant 

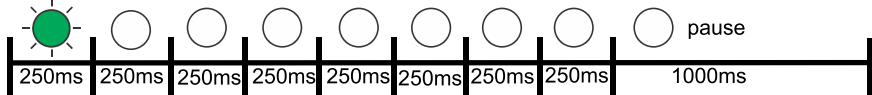

Power LED (green)

No Fault	LED is ON constant 
Fault Condition: AC power loss (or brownout) 1 short blink (250ms)	Repeating LED blink pattern (non-diagnostic mode and diagnostic mode) 

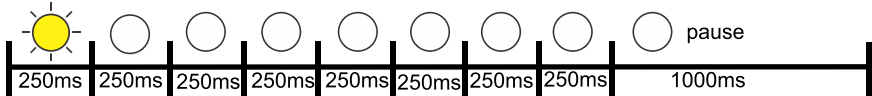
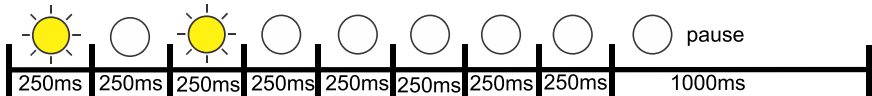
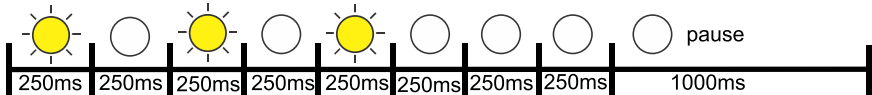
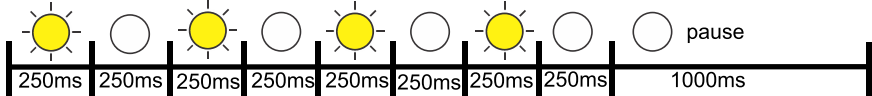

Battery fault LED (yellow)

No Fault	LED is OFF 
Fault Condition: Charging path (FETs) failure 1 short blink (250ms)	Repeating LED blink pattern (non-diagnostic mode and diagnostic mode) 
Fault Condition: Charger voltage too low or Charger Diode Fault 2 short blinks (250ms)	Repeating LED blink pattern (non-diagnostic mode and diagnostic mode) 
Fault Condition: Battery discharged/overcharged 3 short blinks (250ms)	Repeating LED blink pattern (non-diagnostic mode and diagnostic mode) 
Fault Condition: Battery disconnected/fully discharged 4 short blinks (250ms)	Repeating LED blink pattern (non-diagnostic mode and diagnostic mode) 

Output Circuit Status LEDs (red)

Output inactive	LED is OFF 
Output active	LED is ON constant 

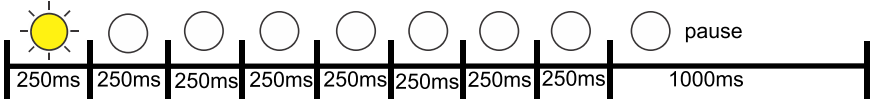
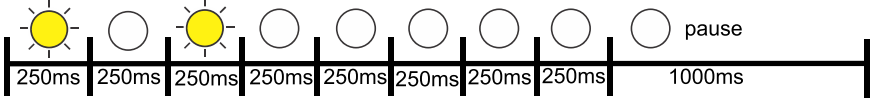
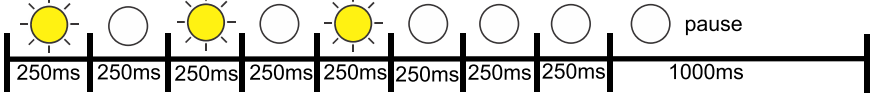
Output Circuit Trouble LEDs (yellow)

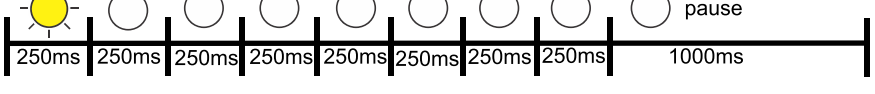
No Fault	LED is OFF 
Fault Condition (Normal/Standby Mode): Wire Supervision Class A or B Open circuit 1 short blink (250ms)	Repeating LED blink pattern (non-diagnostic mode and diagnostic mode) 
Fault Condition (Normal/Standby Mode): Wire Supervision Class A or B Short Circuit 2 short blinks (250ms)	Repeating LED blink pattern (non-diagnostic mode and diagnostic mode) 
Fault Condition: Aux Power Supervision Class A Open circuit (ZNAC-PS Circuit #1 and #2 only) 3 short blinks (250ms)	Repeating LED blink pattern (non-diagnostic mode and diagnostic mode) 
Fault Condition: Power limit condition (individual ckt overload) 4 short blinks per individual circuit (250ms) Fault Condition: Power limit condition (panel overload) 4 short blinks on all output circuits (250ms)	Repeating LED blink pattern (non-diagnostic mode and diagnostic mode) 
Operating Mode Fault: Power Supply not in Normal Operating mode 1 short blink from right to left across all output circuits. Set positions 9 and 10 on S1 to the ON position.	Repeating LED blink pattern (non-diagnostic mode) 

Section 5: Trouble Supervision

The FACP will detect FL-PS power supply faults. Any of the following conditions will cause the trouble contact to open, provided the FACP Notification Appliance Circuit is *not* in alarm.

5.1 Trouble Supervision Using Input Circuits

The FACP (Fire Alarm Control Panel) supervises the connection between itself and the FL-PS via the control panel's NAC End-of-Line Resistor (ELR). To supervise the FL-PS, an ELR must be installed across terminals 1 & 4 of Command Inputs #1 and #2 (and #3 for the 10 amp models). A field wiring fault on the NAC output of the FL-PS will trigger a disconnection of the ELR at the related Command Input, causing a general NAC trouble at the FACP provided the FACP's NAC is *not* in alarm. Refer to Section 3.2, "Output Circuit Control DIP Switch Settings", on page 25 for input/output configuration assignment. The following are exceptions.

1. Resettable Aux Power, Non-Resettable Aux Power, and Door Holder Aux Power outputs that trigger the Trouble relay during an output trouble instead of breaking the ELR connection at the Command Input regardless of the output to input relationship (i.e. mapping). Refer to 5.2, "Trouble Relay" below.
2. Faults are only reported by Command Input #1 when Selective Silence output mode is controlled by Command Input #1 and #2.
3. Faults are only reported by the trigger input when Command Input #1 is configured for Sync Input mode operation controlled by a sync and trigger input.

If the FL-PS is in alarm, only a short circuit on the NAC will be detected as a trouble.

If other trouble monitoring is required when the power supply is in alarm, the Trouble Relay at TB1, and AC Trouble at TB2, and Ground Fault Trouble at TB3 (Canadian applications only) can be used for this purpose.

5.2 Trouble Relay

The FL-PS power supply has a fail-safe Form-C trouble relay located at TB1. The contacts can be monitored by an FACP input circuit or an addressable monitor module as illustrated in Figure 5.1. Note that any faults reported by Command Inputs are not repeated by the trouble relay, offering limited trouble reporting.

Trouble conditions that will cause the normally energized trouble relay to change states regardless of whether the panel is in alarm or standby:

- A battery fail condition at the power supply
- A battery charger fail on the power supply
- A ground fault condition on the power supply (non-Canadian models only)
- A field wiring fault on the FL-PS output in Resettable Aux Power, Non-Resettable Aux Power, or Door Holder Aux Power mode
- A total panel overload fault

If trouble monitoring is required when the power supply is in alarm, the Trouble Relay at TB1 can be used for this purpose. Refer to Figure 5.1 below.



NOTE: The individual NAC Trouble LED will indicate which NAC circuit is in trouble.

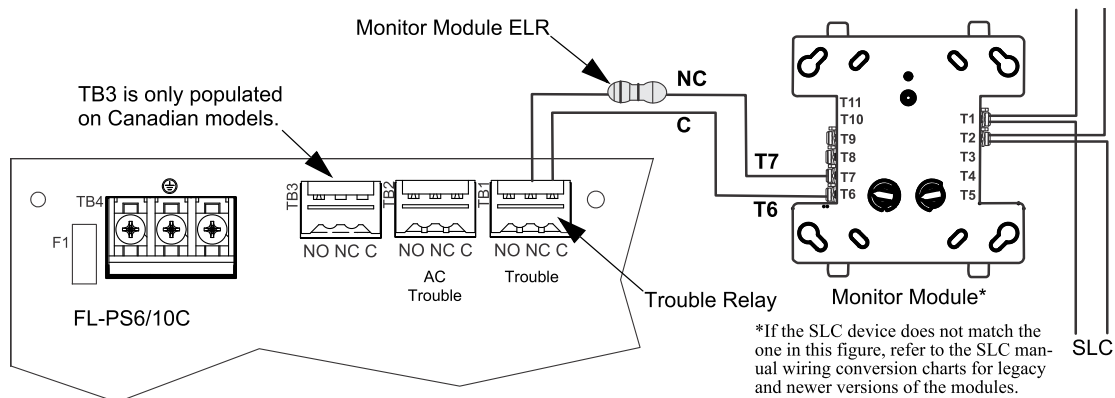

Figure 5.1 Monitoring the Trouble Relay

5.3 AC Trouble Relay

The FL-PS power supply has a fail-safe Form-C trouble relay located at TB2. The contacts can be monitored by an FACP input circuit or an addressable monitor module similar to the drawing illustrated in Figure 5.1. The AC Trouble Relay responds to an AC fail condition on the FL-PS immediately, or after a programmed delay time, depending on the setting of S1 switches 7 and 8.

The reporting of AC loss to a central station is usually delayed in order to prevent multiple transmissions of AC loss and restoration, allowing AC power to stabilize. When a host FACP is programmed to delay AC loss reporting, the FL-PS must be configured to delay the reporting of AC fail. This is accomplished by setting S1 positions 7 and 8. Refer to the DIP switch setting chart in Table 3.5 on page 24. This will prevent AC loss from being reported as a trouble condition for 30, 12, 2, or 0 hours. Note that only no delay and the 2 hour delay are acceptable per UL 864 and UL 2572.

5.4 Ground Fault Relay (Canadian Applications Only)

The FL-PS6/10C power supply has a form-C trouble relay located at TB3. The contacts can be monitored by an FACP input circuit or an addressable monitor module similar to the drawing illustrated in Figure 5.1. Ground fault conditions will cause the relay to change states regardless of whether the panel is in alarm or standby.

Section 6: Power Supply Requirements

6.1 Overview

This section contains instructions and tables for calculating power supply currents in alarm and standby conditions. This is a four-step process, consisting of the following:

1. Calculating the total amount of AC branch circuit current required to operate the system
2. Calculating the power supply load current for secondary non-fire and fire alarm conditions
3. Calculating the size of batteries required to support the system if an AC power loss occurs
4. Selecting the proper batteries for your system

6.2 Calculating the AC Branch Circuit

The power supply requires connection to a separate, dedicated AC branch circuit, which must be labeled **FIRE ALARM**. This branch circuit must connect to the line side of the main power feed of the protected premises. No other non-fire alarm equipment may be powered from the fire alarm branch circuit. The branch circuit wire must run continuously, without any disconnect devices, from the power source to the power supply. Overcurrent protection for this circuit must comply with Article 760 of the National Electrical Codes as well as local codes. Use a minimum of 14 AWG (2.00 mm²) wire with 600 volt insulation for this branch circuit.

Use Table 6.1 to determine the total amount of current, in AC amperes, that must be supplied to the system.

Device Type	Number of Devices		Current Draw (AC amps)		Total Current per Device
FL-PS6(C) or FL-PS10(C)	1	x	5.0 or 6.2	=	
[]	[]	x	[]	=	
[]	[]	x	[]	=	
Sum Column for AC Branch Current Required				=	

Table 6.1 120 VAC Branch Circuit Requirements

6.3 Calculating the System Current Draw

6.3.1 Overview

The power supply must be able to power all internal and external devices continuously during a fire alarm condition. The secondary power source (batteries) must be able to power the system during a primary power loss. To calculate the non-fire alarm load on the power supply when secondary power is applied, use Calculation Column 1 in Table 6.3 on page 34. The power supply must support a larger load current during a fire alarm condition. To calculate the fire alarm load on the power supply as secondary power, use Calculation Column 2 in Table 6.3 on page 34.

When calculating current draw and the battery size, note the following:

- *Primary* refers to the main power source for the power supply.
- *Secondary* refers to the power supply's backup batteries.
- All currents are given in amperes (A). Table 6.2 shows how to convert milliamperes and microamperes to full amperes.

To convert...	Multiply	Example
Milliamperes (mA) to amperes (A)	mA x 0.001	3 mA x 0.001 = 0.003 A
Microamperes (μA) to amperes (A)	μA x 0.000001	300 μA x 0.000001 = 0.0003 A

Table 6.2 Converting to Full Amperes

6.3.2 How to Calculate System Current Draw

Use Table 6.3 to calculate current draws as follows and refer to the battery calculation tool on www.firelite.com.

1. Enter the quantity of devices in both columns.
2. Enter the current draw where required. Refer to the *Fire•Lite Device Compatibility Document* for compatible devices and their current draws.
3. Calculate the current draws for each in both columns.
4. Sum the total current for each column.

Following are the types of current that can be entered into Table 6.3.

- ✓ **Calculation Column 1** - The secondary supply current load that the power supply must support during a non-fire alarm condition, with DC power applied
- ✓ **Calculation Column 2** - The secondary supply current load the power supply must support during a fire alarm condition, with DC power applied

Table 6.3 contains two columns for calculating current draws. For each column, calculate the current and enter the total (in amperes) in the bottom row. When finished, use the data to select the proper size batteries in Tables 6.4 and 6.5.

Device Type	Calculation Column 1 Secondary, Non-Fire Alarm Current (amps)			Calculation Column 2 Secondary, Fire Alarm Current (amps)		
	Qty	X (current draw) =	Total	Qty	X (current draw) =	Total
Main Circuit Board - FL-PS6 with all outputs 2k EOL	1	X [0.154] =		1	X [0.192] =	
Main Circuit Board - FL-PS6 with 4.7k EOL	1	X [0.139] =		1	X [0.157] =	
Main Circuit Board - FL-PS6 with 27k EOL	1	X [0.124] =		1	X [0.137] =	
Main Circuit Board - FL-PS6 with all Outputs Aux Power Class B	1	X [0.132] =		1	X [0.132] =	
Main Circuit Board - FL-PS6 with ZNAC-PS Class A option card with all outputs Aux Power	1	X [0.142] =		1	X [0.142] =	
Main Circuit Board - FL-PS10 with all outputs 2k EOL	1	X [0.178] =		1	X [0.232] =	
Main Circuit Board - FL-PS10 with 4.7k EOL	1	X [0.156] =		1	X [0.185] =	
Main Circuit Board - FL-PS10 with 27k EOL	1	X [0.135] =		1	X [0.154] =	
Main Circuit Board - FL-PS10 with all Outputs Aux Power Class B	1	X [0.149] =		1	X [0.149] =	
Main Circuit Board - FL-PS10 with ZNAC-PS Class A option card with all outputs Aux Power	1	X [0.160] =		1	X [0.160] =	
NAC/Output #1	[]	X [] =		[]	X [] =	
NAC/Output #2	[]	X [] =		[]	X [] =	
NAC/Output #3	[]	X [] =		[]	X [] =	
NAC/Output #4	[]	X [] =		[]	X [] =	
NAC/Output #5	[]	X [] =		[]	X [] =	
NAC/Output #6	[]	X [] =		[]	X [] =	
NAC/Output #7	[]	X [] =		[]	X [] =	
EOLR-1 Power Supervision Relay	[]	X [0.020] =		[]	X [0.020] =	
Sum each column for totals		Secondary Non-Alarm =		Secondary Alarm =		

Table 6.3 System Current Draw Calculations

6.4 Selecting and Locating Batteries

Select batteries that meet or exceed the total ampere hours determined in Tables 6.4 and 6.5. The power supply can charge batteries from 7 AH to 33 AH range. The power supply cabinet is capable of housing industry standard 7 AH or 18 AH batteries. Other ampere batteries (e.g. 12AH, 26AH, 33AH) will not fit physically inside the FL-PS cabinet and require a separate battery box.

6.4.1 NFPA Battery Requirements

NFPA 72 Local and Proprietary Fire Alarm Systems require 24 hours of standby power followed by 5 minutes in alarm for normal operations, 15 minutes for mass notification systems, or 30 minutes for Canadian applications.



NOTE: When using carbon monoxide detection, the system must be monitored by a Supervising Station meeting the Standard for the Installation of Carbon Monoxide (CO) Detection and Warning Equipment, NFPA 720.

6.4.2 Maximum Battery Standby Load

Tables 6.4 and 6.5 show the standby load calculations for the power supply based on 24 hours of standby. The standby load calculations in the Table 6.3 must be less than the number shown in Tables 6.4 and 6.5 for the selected battery size, standby hour and alarm time. The numbers below have a built in 20% derating factor for the battery ampere capacity.

Battery Capacity (AH)	Alarm Time (min)				
	5	10	15	20	30
7	0.212 A	0.190 A	0.169 A	0.147 A	N/A
12	0.379 A	0.357 A	0.336 A	0.314 A	0.271 A
18	0.579 A	0.557 A	0.536 A	0.514 A	0.471 A
33	1.079 A	1.057 A	1.036 A	1.014 A	0.971 A
75	2.479 A	2.457 A	2.436 A	2.414 A	2.371 A
120	3.000 A	3.000 A	3.000 A	3.000 A	3.000 A

Table 6.4 Maximum Battery Standby Loads for 24 Hour Standby on the FL-PS6

Battery Capacity (AH)	Alarm Time (min)				
	5	10	15	20	30
7	0.198 A	0.162 A	N/A	N/A	N/A
12	0.364 A	0.329 A	0.293 A	0.258 A	0.187 A
18	0.564 A	0.529 A	0.493 A	0.458 A	0.387 A
33	1.064 A	1.029 A	0.993 A	0.958 A	0.887 A
75	2.464 A	2.429 A	2.393 A	2.358 A	2.287 A
120	3.000 A	3.000 A	3.000 A	3.000 A	3.000 A

Table 6.5 Maximum Battery Standby Loads for 24 Hour Standby on the FL-PS10

Section 7: Testing and Maintenance

7.1 Periodic Testing and Service

Periodic testing and servicing of equipment is essential to ensure proper and reliable operation. Test and service the power supply according to the schedules and procedures outlined in the following documents:

- NFPA Standard 72's section on Inspection, Testing and Maintenance
- All test and maintenance instruction codes and software necessary to provide test and inspection requirements of CAN/ULC-S536, Standard for the Inspection and Testing of Fire Alarm Systems

7.2 Battery Checks and Maintenance

Maintenance-free sealed lead-acid batteries used in the system do not require the addition of water or electrolyte. These batteries are charged and maintained in a fully charged state by the main power supply's charger during normal system operation. A discharged battery typically reaches the voltage of 27.6 VDC within 48 hours;. Sealed lead-acid batteries must be replaced within at most 5 years from their date of manufacture. Minimal replacement battery capacity appears on the control panel marking label. Immediately replace a leaking or damaged battery. Replacement batteries are available from the manufacturer.



WARNING: SULFURIC ACID

BATTERIES CONTAIN SULFURIC ACID WHICH CAN CAUSE SEVERE BURNS TO THE SKIN AND EYES AND DAMAGE TO FABRICS.

F1 Fuse Replacement	Not Allowed
Rechargeable Battery Replacement	Recommended Part Numbers: <ul style="list-style-type: none"> • BAT-1270 (12V,7AH) • BAT-12120 (12V, 12AH) • BAT-12180 (12V 18AH) • BAT-12260 (12V, 26AH) • BAT-12330 (12V, 33AH)

Appendix A: Wire Requirements

Connecting external system accessories to the main circuits must be carefully considered to ensure proper operation. It is important to use the correct type of wire, gauge and run length for each circuit. The following table lists NAC wiring requirements for the FL-PS6 and FL-PS10 Power Supply.

The numbers documented in this chart are worst case numbers, based on the conditions listed below. The maximum voltage drop, maximum loop resistance, and wire length ratings can be increased with lower system current loading.

1. The FL-PS6/10 is full capacity loaded at 6A/10A.
2. The FL-PS6/10 is running at the Low Battery voltage of 20.4VDC (at Battery Connector TB15).

Wire lengths apply to Class B wiring, and to Class A wiring returned to the ZNAC-PS card.

Max Load (Amps)	Max Loop Resistance (Ohms)	AWG 12 (Solid)	AWG 14 (Solid)	AWG 16 (Solid)	AWG 18 (Solid)
0.25	12.804	3320	2087	1310	823
0.50	6.402	1660	1044	655	412
0.75	4.268	1107	696	437	274
1.00	3.201	830	522	327	206
1.25	2.561	664	417	262	165
1.50	2.134	553	348	218	137
1.75	1.829	474	298	187	118
2.00	1.601	415	261	164	103
2.25	1.423	369	232	146	91
2.50	1.280	332	209	131	82
2.75	1.164	302	190	119	75
3.00	1.067	277	174	109	69

Table A.1 Wiring Requirements for Power Supply



NOTE: Calculations are based on Direct-Current Resistance data for uncoated copper wire, per National Electrical Code (2005 Edition) Table 8, Conductor Properties.



NOTE: These distances reflect the worst case scenario and are based on the correct draw of the highest candela strobes at the low end of the supported NAC voltage with the entire load at the end of the circuit. Further distances can be achieved by performing a point to point voltage calculation that more accurately reflects the specific devices used and how they are dispersed on the circuit.

Appendix B: Application Examples

B.1 Controlling NACs For Selective Silence Operation Using a Control Module

In this application, the power supply has been set as a master with synchronized outputs and selective silence (see DIP switch settings and Selective Silence Operation information in Section 3). This application requires Input #1 to be controlled by the FACP. Input #2 is required for controlling selective silence via a control/relay module, *programmed as an alarm output and a silenceable point*. Only Mass Notification, Fire, or combo Mass Notification/Fire NACs are allowed in this configuration. The control module can be powered by one of the FL-PS output circuits, configured as aux power (24VDC).

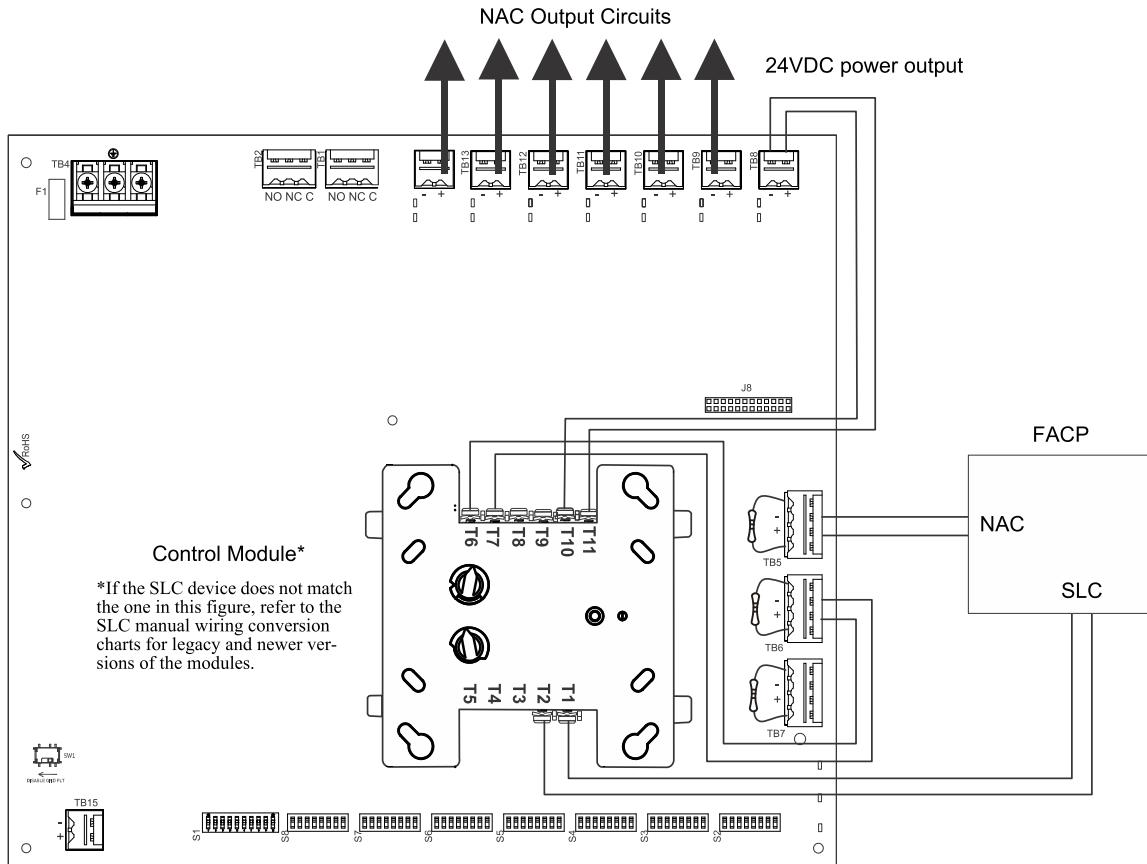

Figure B.1 Controlling Multiple Outputs with One Input

The following notes apply to Figure B.1.

When the FL-PS power supply is in an inactive state (FACP NAC not active), a trouble on the NAC circuit will result in an open circuit condition on the FACP (monitored by End-of-Line Resistor across TB5, Terminals 1 and 4). As an alternative, the trouble contacts at TB1 of the power supply can also be used for limited trouble monitoring excluding Selective Silence output faults. Refer to Section 5 for more information.

- Refer to Section 3 for instructions on setting the DIP switches.
- Selective Silence output faults are only reported via Command Input #1 (not Command Input #2).
- Wire NACs as shown on page 13.
- Do not loop wires under screw terminals. Break wires to maintain proper supervision.
- An End-of-Line Resistor must be installed across all input circuits, Terminals 1 and 4, for control module wiring supervision (the ELR value is dependent on the module/FACP employed).
- For a list of compatible devices, refer to the *Fire•Lite Device Compatibility Document #15384*.
- Refer to the *SLC Wiring Manual* for more information.

B.2 Controlling NACs For Sync Follower Operation Using a Control Module

In this application, the power supply has been set to operate in slave mode and will follow the sync signal from the FACP. This application requires Input #1 to be controlled by the FACP sync output. Input #1 may be wired to the next FL-PS or terminate in an ELR. Input #2 (or Input #3, if available) will act as the trigger signal for the output circuits. The control module can be powered by one of the FL-PS output circuits, configured as aux power (24VDC). See Table 3.14 on page 27 DIP switch settings.

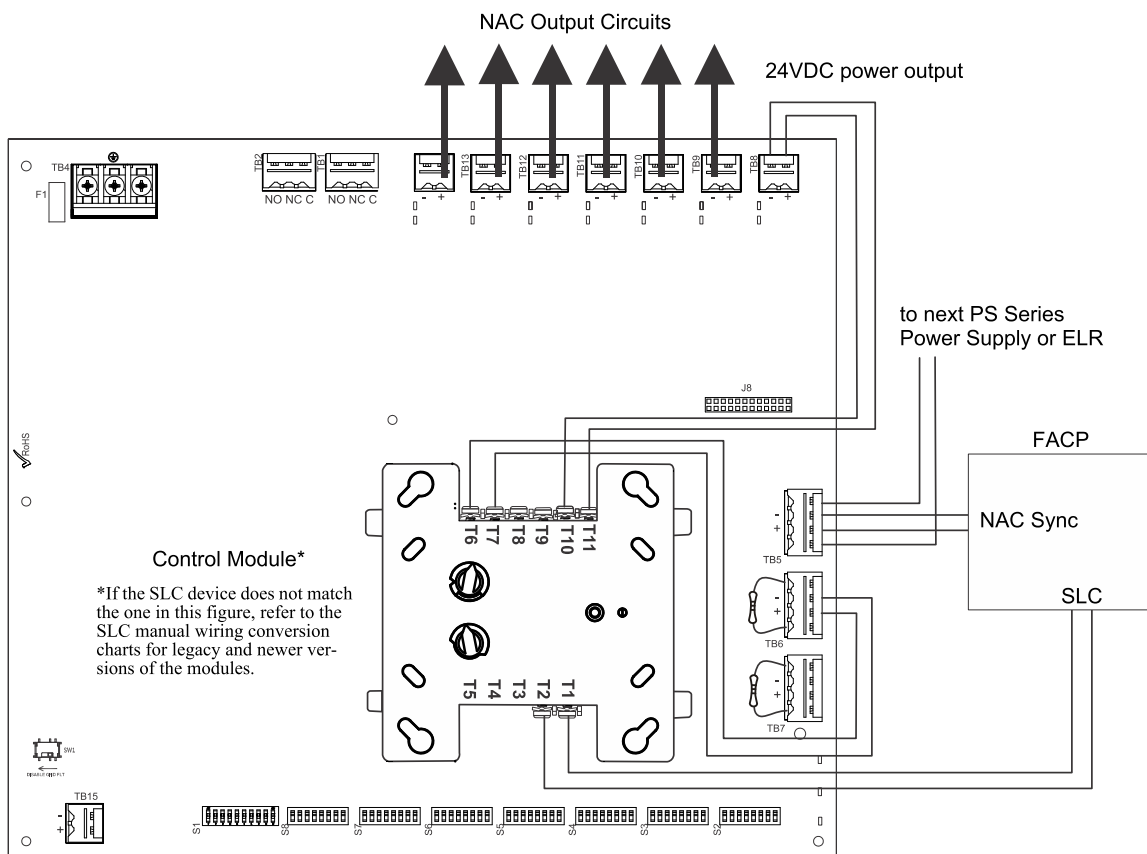

Figure B.2 Controlling Multiple Outputs with One Input as Sync Follower

The following notes apply to Figure B.2.

- When the FL-PS power supply is in an inactive state (control module not active), a trouble on the NAC circuits mapped to TB6 will result in an open circuit condition on the control module output circuit (monitored by End-of-Line Resistor across TB6, Terminals 1 and 4). As an alternative, the trouble contacts at TB1 of the power supply can also be used for limited trouble monitoring excluding faults reported by Command Input #2 related to Command Input #1 configured for Sync Input mode. Refer to Section 5 for more information.
- Refer to Section 3 for instructions on setting the DIP switches.
- Output faults are reported via Command Input #2 with Command Input #1 configured for Sync Input mode operation.
- Refer to the FACP manual for load restrictions and line length limitations when wiring multiple power supplies at the input.
- Wire NACs as shown on page 13.
- Do not loop wires under screw terminals. Break wires to maintain proper supervision.
- An End-of-Line Resistor must be installed across all input circuits, Terminals 1 and 4, for control module wiring supervision (the ELR value is dependent on the module/FACP employed).
- For a list of compatible devices, refer to the *Fire•Lite Device Compatibility Document #15384*.
- Refer to the *SLC Wiring Manual* for more information.

B.3 Controlling NACs, Aux Power, or Door Holders Using a Control Module

All output circuits, NACs, aux power (non-resettable power – active regardless of control module state), or door holders, can be controlled from one input such as an addressable control module as illustrated in Figure B.3. The control module can be powered from one of the FL-PS output circuits, as 24 VDC power. In this example, Output #1 will be configured as 24VDC non-resettable aux power. The control module is shown to demonstrate the use of an internally mounted device associated with an addressable fire alarm control panel. The module could be replaced with any circuit capable of polarity reversal, such as an FACP Notification Appliance Circuit.

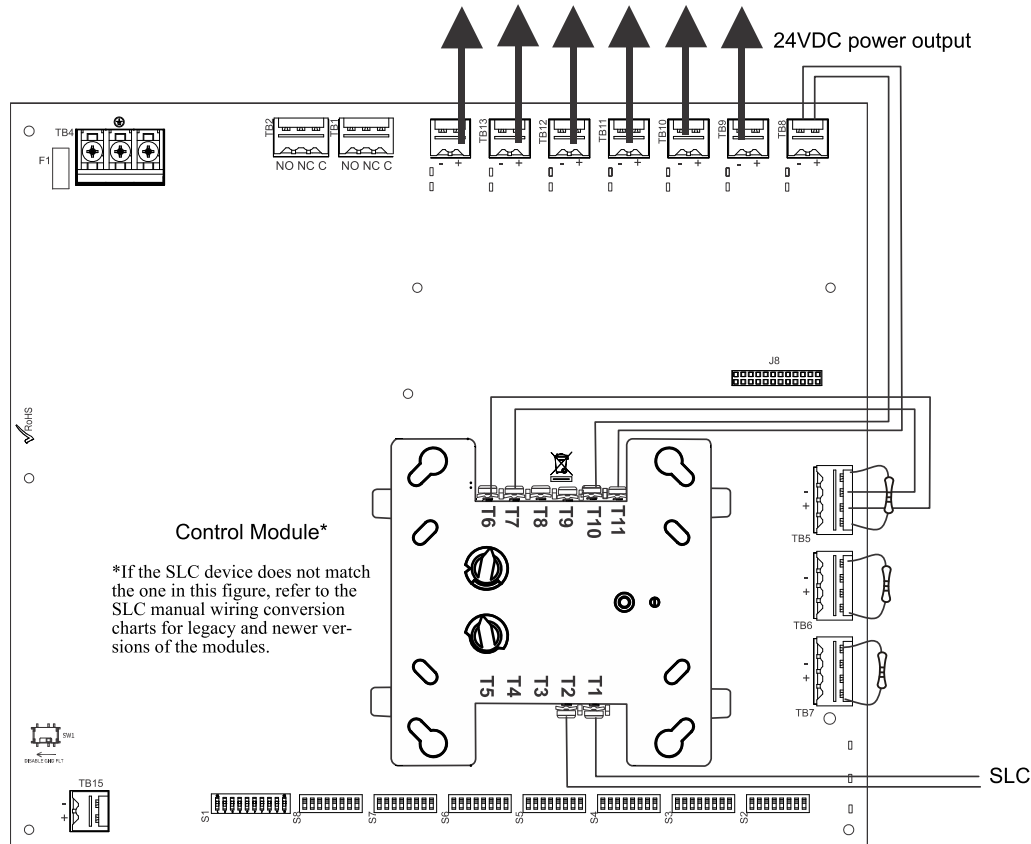

Figure B.3 Controlling NACs, Aux Power, and Door Holders with One Input

The following notes apply to Figure B.3.

- Any output circuit can be configured as NAC, door holder, or 24VDC power.
- Wire NACs as shown on page 13.
- Refer to Section 3 for instructions on setting the DIP switches.
- When the FL-PS power supply is in an inactive state (control module not active), a trouble on the NAC circuits mapped to TB5 will result in an open circuit condition on the control module output circuit (monitored by an End-of-Line Resistor across Terminals 1 and 4). Additionally, the trouble contacts at TB1 of the power supply can also be used for limited trouble monitoring excluding output faults reporting to Command Input #1. Refer to Section 5 for more information.
- Do not loop wires under screw terminals. Break wires to maintain proper supervision.
- An End-of-Line Resistor must be installed between terminals 1 and 4 for control module wiring supervision (the ELR value is dependent on the module/FACP employed).
- For a list of compatible devices, refer to the *Fire•Lite Device Compatibility Document* #15384.
- Refer to the *SLC Wiring Manual* for more information.

B.4 Controlling NACs, Aux Power, and Door Holders with NAC Sync

In this application, use of a single CDRM-300 mounted inside the cabinet can monitor the two power supply trouble relays and trigger two independent inputs via relay circuits. FL-PS outputs #1 and #2 are being used for 24 VDC aux power triggered by the module's relay circuits. Any FL-PS output circuit can be configured to follow any input circuit.

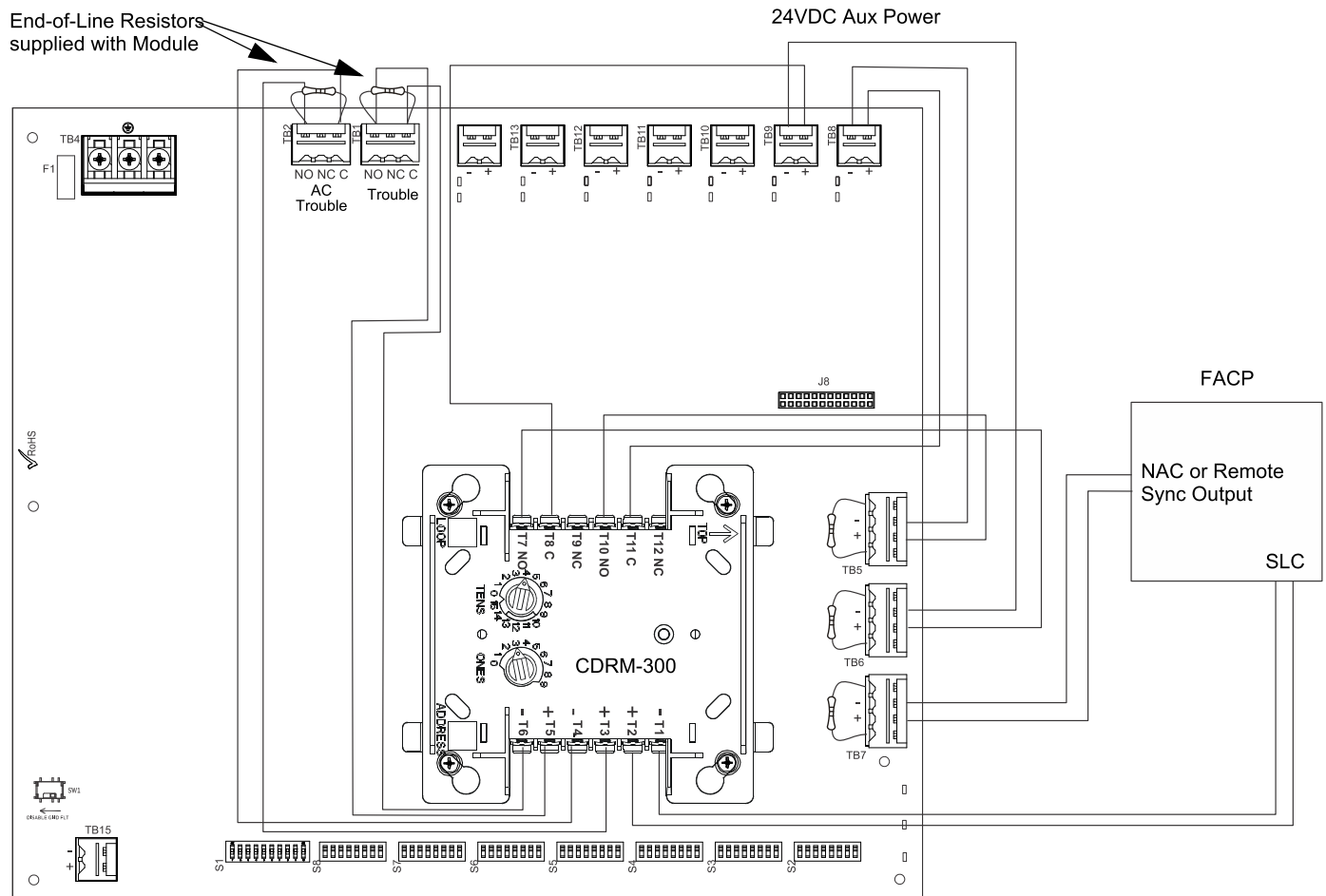

Figure B.4 Controlling NACs, Aux Power, and Door Holders with One Input and NAC Sync

The following notes apply to Figure B.4.

- Any output circuit can be configured as NAC, door holder, or 24VDC power.
- Refer to Section 3 for instructions on setting the DIP switches.
- Do not loop wires under screw terminals. Break wires to maintain proper supervision.
- An End-of-Line Resistor must be installed between terminals 1 and 4 for module wiring supervision (the ELR value is dependent on the module/FACP employed).
- An End-of-line Resistor on input circuits#1-2 (TB5-6) are optional for this particular application.
- Ensure that the CDRM-300 is programmed appropriately at the FACP where the inputs are *not* mapped to the same zone as its outputs.
- For a list of compatible devices, refer to the *Fire•Lite Device Compatibility Document #15384*.
- Refer to the *SLC Wiring Manual* for more information.

B.5 Controlling all Three Inputs with One Control Module

In this application, all three command inputs are being controlled by one multi-module, the CMF-300-6 mounted inside the cabinet. Output #1 is being used for 24 VDC aux power. Any output circuit may be configured to any input.

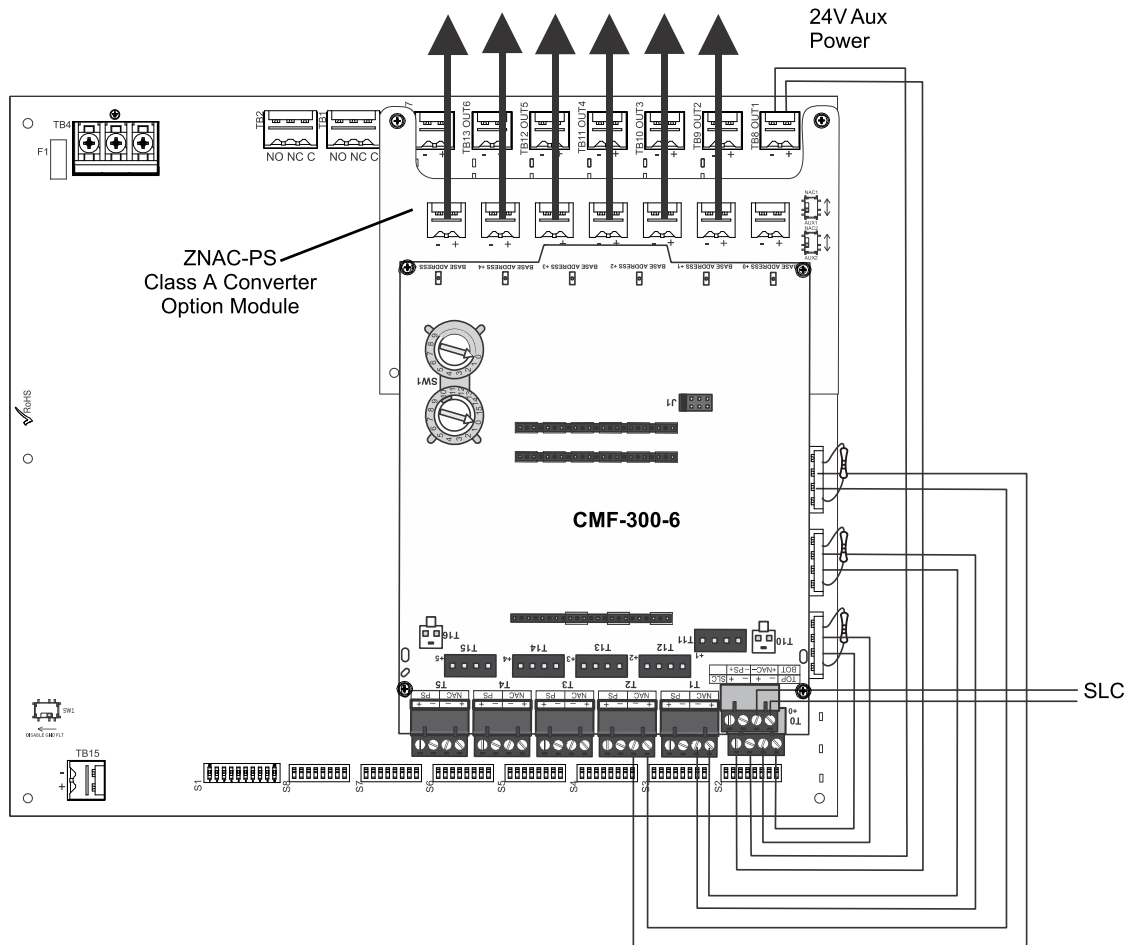

Figure B.5 Controlling Three Inputs with One Module

The following notes apply to Figure B.5.

- An End-of-Line Resistor must be installed between terminals 1 and 4 for control module wiring supervision (the ELR value is dependent on the module/FACP employed).
- Either disable the unused addresses or install ELRs across unused outputs on the CMF-300-6.
- Refer to Section 3 for instructions on setting the DIP switches.
- Do not loop wires under screw terminals. Break wires to maintain proper supervision.
- For a list of compatible devices, refer to the *Fire•Lite Device Compatibility Document #15384*.
- Refer to the *SLC Wiring Manual* for more information.

B.6 AC Trouble Reporting with a Conventional FACP

In this application, the FL-PS is being used with a conventional FACP that does not have a type-coded input zone for AC Power loss with a delay. AC Trouble Delay on the FL-PS must be set to none (S1-7 ON, 8 ON). AC Fail delay timers must be set on the DACT. The DACT must be installed in close proximity to the conventional FACP so the audible and visual signaling can be given locally at the FACP as required by UL 864.

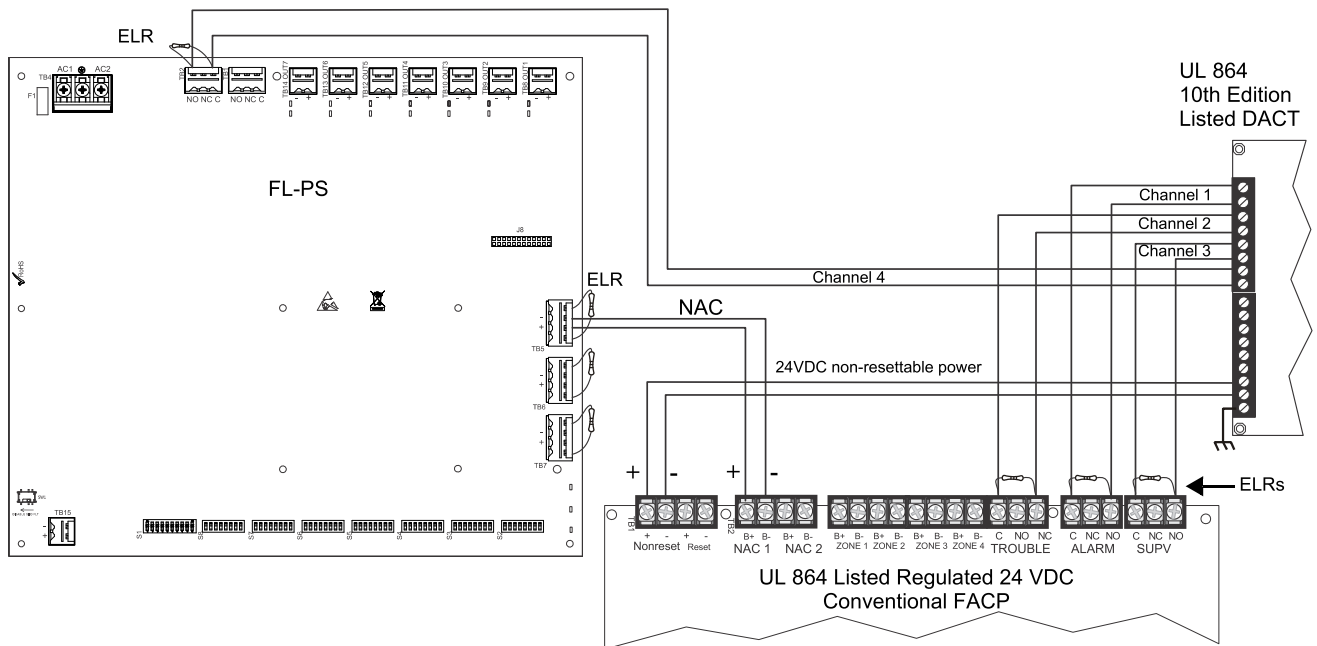

Figure B.6 AC Trouble Reporting with a Conventional FACP

The following notes apply to Figure B.6.

- Wiring from the power supply to the DACT must be in metal conduit within 20 feet of the FACP.
- Refer to Section 3 for instructions on setting the DIP switches.
- Do not loop wires under screw terminals. Break wires to maintain proper supervision.
- An End-of-Line Resistor must be installed between terminals 1 and 4 on the input circuits that require wiring supervision. (The ELR value is dependent on the FACP employed).
- Refer to panel/DACT documentation for programming information.

B.7 Canadian Two-Stage

In this application, NAC1 from the Host FACP is providing the Canada 2-stage audible pattern to the FL-PS and NAC. NAC2 is providing Master Sync or a Steady Output, depending on its capabilities.

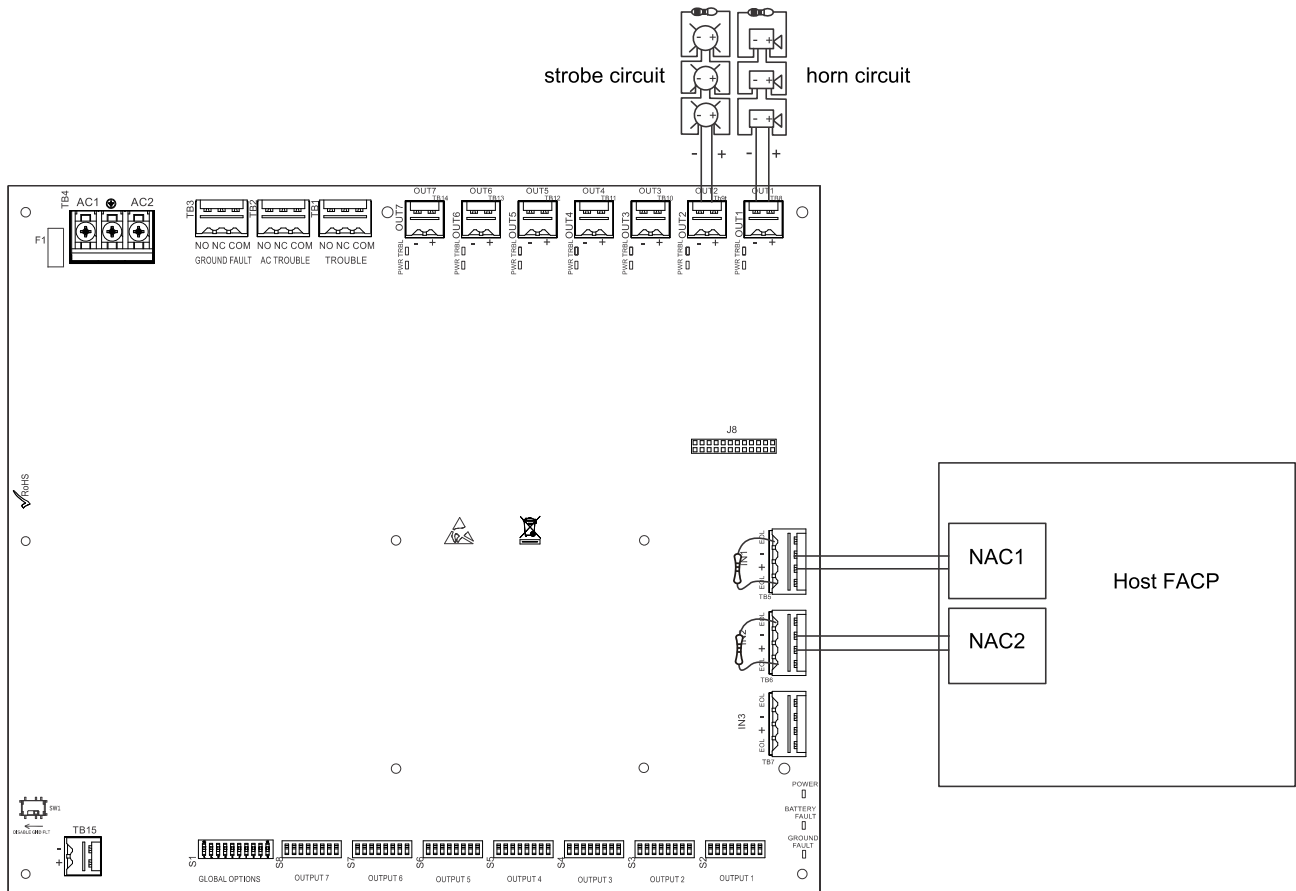

Figure B.7 Canadian Two-Stage Wiring

The following notes apply to Figure B.7.

- FL-PS Output #1 is programmed to activate on Command Input #1 and slave mode (NAC follower).
- FL-PS Output #2 is programmed depending on the host FACP capabilities.
 - FACP NAC2 provides master sync: FL-PS Output #2 activate on Command Input 2, slave mode (NAC follower)
 - FACP NAC2 provides steady output: FL-PS Output #2 activate Command Input 2, master mode (select appropriate strobe manufacturer)
- Additional FL-PS outputs can be mapped to command inputs and used to drive additional visual/audible or FL-PS units.

B.8 Canada Two-Stage Application Using CMF-300-6

In this application, two outputs are being controlled by a CMF-300-6 multi-module inside the cabinet. NAC1 from the host FACP is providing the Canada two-stage audible pattern to the FL-PS. NAC2 is providing master sync or a steady output, depending on its capabilities. Additional FL-PS outputs can be used to connect to CMF-300-6 modules outside the cabinet.

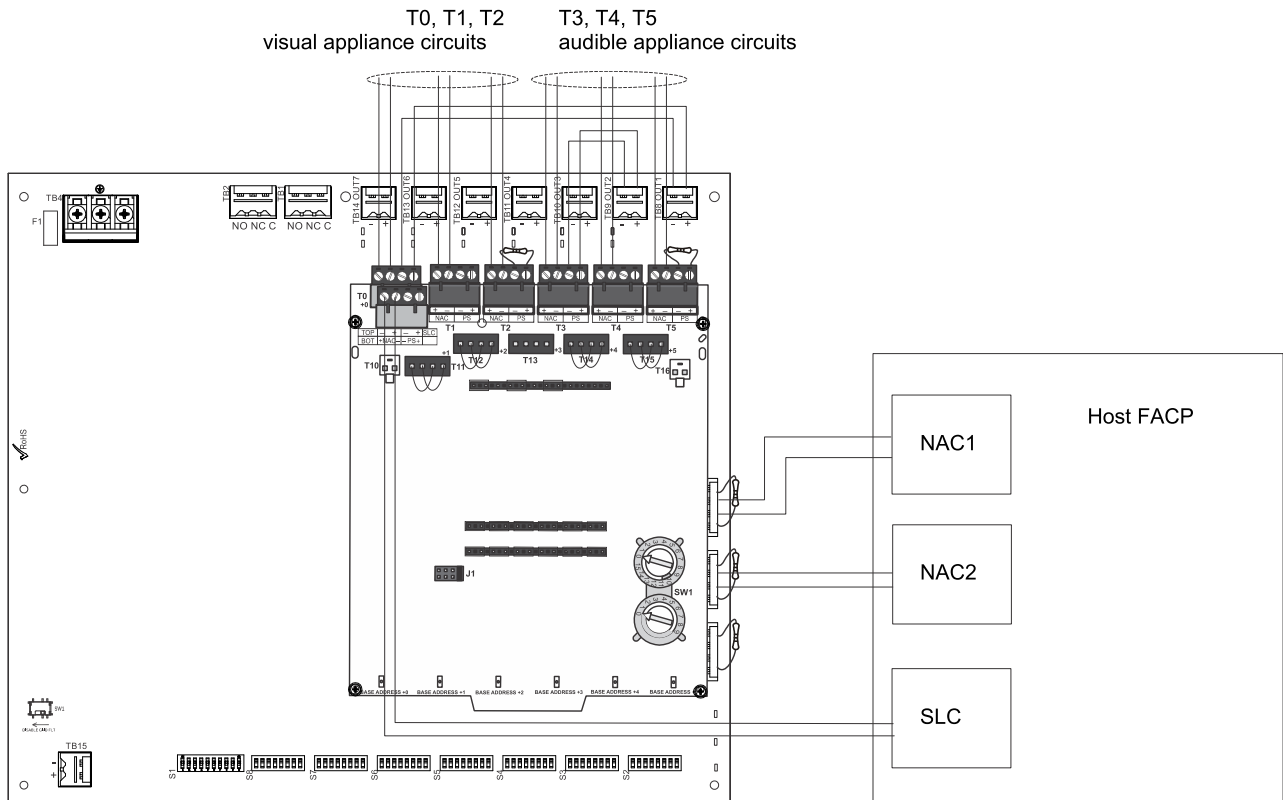

Figure B.8 Canadian Two-Stage Wiring Using a CMF-300-6

The following notes apply to Figure B.8.

- FL-PS Output #1 is programmed to activate on Command Input #1 and Slave Mode (NAC Follower).
- FL-PS Output #2 is programmed depending on host FACP capabilities:
 - FACP NAC2 provides master sync: FL-PS output #2 activate on Command Input 2, slave mode (NAC follower)
 - FACP NAC2 provides steady output: FL-PS output #2 activate Command Input 2, master mode (select appropriate strobe manufacturer)
- Jumpers must be installed on terminals T11, T12, T14, and T15 of the CMF-300-6 module.
- Unused control module NAC outputs need ELRs installed or must be disabled.
- FL-PS outputs going to CMF-300-6 need ELRs installed.
- Due to the reverse-polarity supervision of the FL-PS outputs, the CMF-300-6 points must have the type code, “Bell Circuit”, to prevent “Ext Power Loss” troubles.

Index

A

AC power 8
 calculations 33
 current 8, 9
 fail 24
 fail delay 24
 loss 8
 loss relay 9
 loss reporting delay 8, 31
 loss timer 23
 voltage 8, 9
activation
 reverse polarity 8
alarm condition 8
applications 8
aux power 25
aux power control
 see also resettable or non-resettable power 26

B

backbox dimensions 12
battery 20
 capacity 9
 charge current 9
 charger capacity 8
 float charge voltage 9
 lead acid 8, 9
 maximum capacity 8
 see also secondary power 9
 trouble 8

C

cabinet
 see also backbox 12
Canadian applications 19
capacity
 battery 9
cascading 18, 20
charge current
 maximum 9
 nominal 9
charger
 enable/disable 24
charger trouble 8
circuit board
 layout 10
Class A Converter Module 13
 see also ZNAC-PS 8
Class B 8
coding
 NAC 8
command circuit 8
 current 9
 see also input circuit 9
 voltage 9
command input 24
compatibility
 input circuit 8
current

 maximum continuous 8
 maximum short term 8
 standby 9
 total continuous 9
 total short term 9

D

debounce/dejitter 23
dimensions
 backbox 12
DIP switch
 settings 23, 25
disable outputs 26
door holder 26
dropout delay 23

E

ELR 9, 13, 31, 37, 38, 39, 40, 41, 42

F

factory default 26
faults 31
features 8
filtered power 8
float charge voltage 9
FL-PS10 8
FL-PS6 8
form-C
 see also relay 8

G

ground fault 8, 18, 20
ground fault detection 8, 10
 switch SW1 10

I

input 24
 current 9
 settings 25
 voltage 9
input circuit 8
 activation 8
 compatibility 8
 see also control 9
installation 12

M

master mode 26
module
 mounting 14
mounting
 see also installation 12
multi-module
 mounting 14

N

NAC
 activation 8

circuit wiring 13
Class
 see also NFPA Class 8
coding 8
output
 see also output circuit 9
 see also Notification Appliance Circuit 8
NEC power-limited wiring requirements 15
non-alarm state 8
non-resettable power 25, 26
notification appliance circuit
 see also NAC 8

O

operating mode 23, 24
output
 disable 26
 unused 26
output circuit 9
 Class 9
 current 9
 maximum current 8, 9
 see also NAC output 9
 types 9
 voltage rating 9
output power 8

P

power
 non-resettable 8
 resettable 8
power supply 33
 board layout drawing 10
 connectors and switches 10
power-limited outputs 8
power-limited wiring 15

R

relay
 trouble 8, 9, 31
reporting delay
 AC loss 31
requirements 33
resettable power 25, 26

S

secondary power
 see also battery 9
selective silence 27
slave mode 25, 26
special operating mode 24
specifications 8
startup procedure 10
strobe synchronization 8
supervision 8
 trouble 31
SW1
 ground fault detection 10
switch

- SW1 ground fault detection **8, 10**
- sync **26**
- sync mode **24**
- sync type **16, 26, 27**
- synchronization
 - ADA compatible **8**
 - selectable **8**

T

- trouble **31**
 - power supply **8**
 - supervision **31**
- trouble relay **8, 9, 31**
 - contact rating **9**
- trouble supervision **8**

W

- wiring **8**
 - AC power **9**
 - power-limited **15**

Z

- ZNAC-PS **13, 14**
 - see also Class A Converter Module **8**

Manufacturer Warranties and Limitation of Liability

Manufacturer Warranties. Subject to the limitations set forth herein, Manufacturer warrants that the Products manufactured by it in its Northford, Connecticut facility and sold by it to its authorized Distributors shall be free, under normal use and service, from defects in material and workmanship for a period of thirty six months (36) months from the date of manufacture (effective Jan. 1, 2009). The Products manufactured and sold by Manufacturer are date stamped at the time of production. Manufacturer does not warrant Products that are not manufactured by it in its Northford, Connecticut facility but assigns to its Distributor, to the extent possible, any warranty offered by the manufacturer of such product. This warranty shall be void if a Product is altered, serviced or repaired by anyone other than Manufacturer or its authorized Distributors. This warranty shall also be void if there is a failure to maintain the Products and the systems in which they operate in proper working conditions.

MANUFACTURER MAKES NO FURTHER WARRANTIES, AND DISCLAIMS ANY AND ALL OTHER WARRANTIES, EITHER EXPRESSED OR IMPLIED, WITH RESPECT TO THE PRODUCTS, TRADEMARKS, PROGRAMS AND SERVICES RENDERED BY MANUFACTURER INCLUDING WITHOUT LIMITATION, INFRINGEMENT, TITLE, MERCHANTABILITY, OR FITNESS FOR ANY PARTICULAR PURPOSE. MANUFACTURER SHALL NOT BE LIABLE FOR ANY PERSONAL INJURY OR DEATH WHICH MAY ARISE IN THE COURSE OF, OR AS A RESULT OF, PERSONAL, COMMERCIAL OR INDUSTRIAL USES OF ITS PRODUCTS.

This document constitutes the only warranty made by Manufacturer with respect to its products and replaces all previous warranties and is the only warranty made by Manufacturer. No increase or alteration, written or verbal, of the obligation of this warranty is authorized. Manufacturer does not represent that its products will prevent any loss by fire or otherwise.

Warranty Claims. Manufacturer shall replace or repair, at Manufacturer's discretion, each part returned by its authorized Distributor and acknowledged by Manufacturer to be defective, provided that such part shall have been returned to Manufacturer with all charges prepaid and the authorized Distributor has completed Manufacturer's Return Material Authorization form. The replacement part shall come from Manufacturer's stock and may be new or refurbished. THE FOREGOING IS DISTRIBUTOR'S SOLE AND EXCLUSIVE REMEDY IN THE EVENT OF A WARRANTY CLAIM.

Warn-HL-08-2009.fm

ISO 9001
CERTIFIED
ENGINEERING & MANUFACTURING
QUALITY SYSTEMS

One Fire-Lite Place, Northford, CT 06472-1601 USA
USA - Phone: (203) 484-7161
Canada - Phone: (905) 856-8733
www.firelite.com

 **FIRE-LITE ALARMS**
by Honeywell

FL-PS10 Battery Calculation

Secondary Power Source Requirements

Device Type	Standby Current (amps)				Secondary Alarm Current (amps)					
	Qty		Current Draw	Total	Qty		Current Draw	Total		
Main Circuit Board										
Choose EOLR used ↓										
4.7k	1	X	0.1560	=	0.1560	1	X	0.1850	=	0.1850
Main Circuit Board with ZNAC-PS Class A card	0	X	0.1490	=	0.0000	0	X	0.1590	=	0.0000
NAC / Output # 1	1	X	0.0000	=	0.0000	1	X	1.4340	=	1.4340
NAC / Output # 2	1	X	0.0000	=	0.0000	1	X	0.6640	=	0.6640
NAC / Output # 3	1	X	0.0000	=	0.0000	1	X	0.6640	=	0.6640
NAC / Output # 4	1	X	0.0000	=	0.0000	1	X	0.6640	=	0.6640
NAC / Output # 5	1	X	0.0000	=	0.0000	1	X	0.6640	=	0.6640
NAC / Output # 6	1	X	0.0000	=	0.0000	1	X	0.0000	=	0.0000
NAC / Output # 7	1	X	0.0000	=	0.0000	1	X	0.0000	=	0.0000
Total Standby Load					0.1560	Total Alarm Load				4.2750

FL-PS10 Battery Calculation

Note 1: You are **fully responsible for verifying these calculations.**

Note 2: You only need to make entries in the **yellow** cells

Calculation in Total Sheet

		Required Standby Time in Hours				
		24 Hours				
Standby Load Current (Amps)	0.1560 Amps	X	24	=	3.744 AH	
		Required Alarm Time in Hours				
		15 Minutes				
Alarm Load Current (Amps)	4.2750 Amps	X	0.25	=	1.069 AH	
Total Current Load					4.81 AH	
		*Multiply by the Derating Factor		1.2	=	x 1.20
Total Ampere Hours Required					5.78 AH	

Recommended Batteries:

BAT-1270 - 7AH Batteries

* Derating Factor required to compensate for the non-linear discharge characteristic of a battery.

FL-PS10 Circuit Detail

NAC / Output # 1

Device	Qty		Non-Alarm Draw	Total	Qty		Alarm Draw	Total		
P2RK	6	x	0.000000	=	0.000000	6	x	0.212000	=	1.272000
P2RL-LF	1	x	0.000000	=	0.000000	1	x	0.162000	=	0.162000

	0	x	0.000000	=		0	x	0.000000	=		
	0	x	0.000000	=		0	x	0.000000	=		
	0	x	0.000000	=		0	x	0.000000	=		
	0	x	0.000000	=		0	x	0.000000	=		
	0	x	0.000000	=		0	x	0.000000	=		
	0	x	0.000000	=		0	x	0.000000	=		
	0	x	0.000000	=		0	x	0.000000	=		
	0	x	0.000000	=		0	x	0.000000	=		
	0	x	0.000000	=		0	x	0.000000	=		
	0	x	0.000000	=		0	x	0.000000	=		
Total Standby Load					0.000000	Total Alarm Load					0.664000

NAC / Output # 6											
Device	Qty		Non-Alarm Draw	=	Total	Qty		Alarm Draw	=	Total	
	0	x	0.000000	=		0	x	0.000000	=		
	0	x	0.000000	=		0	x	0.000000	=		
	0	x	0.000000	=		0	x	0.000000	=		
	0	x	0.000000	=		0	x	0.000000	=		
	0	x	0.000000	=		0	x	0.000000	=		
	0	x	0.000000	=		0	x	0.000000	=		
	0	x	0.000000	=		0	x	0.000000	=		
	0	x	0.000000	=		0	x	0.000000	=		
	0	x	0.000000	=		0	x	0.000000	=		
	0	x	0.000000	=		0	x	0.000000	=		
	0	x	0.000000	=		0	x	0.000000	=		
	0	x	0.000000	=		0	x	0.000000	=		
	0	x	0.000000	=		0	x	0.000000	=		
	0	x	0.000000	=		0	x	0.000000	=		
Total Standby Load					0.000000	Total Alarm Load					0.000000

NAC / Output # 7											
Device	Qty		Non-Alarm Draw	=	Total	Qty		Alarm Draw	=	Total	
	0	x	0.000000	=		0	x	0.000000	=		
	0	x	0.000000	=		0	x	0.000000	=		
	0	x	0.000000	=		0	x	0.000000	=		
	0	x	0.000000	=		0	x	0.000000	=		
	0	x	0.000000	=		0	x	0.000000	=		
	0	x	0.000000	=		0	x	0.000000	=		
	0	x	0.000000	=		0	x	0.000000	=		
	0	x	0.000000	=		0	x	0.000000	=		
	0	x	0.000000	=		0	x	0.000000	=		
	0	x	0.000000	=		0	x	0.000000	=		
	0	x	0.000000	=		0	x	0.000000	=		
	0	x	0.000000	=		0	x	0.000000	=		
	0	x	0.000000	=		0	x	0.000000	=		
	0	x	0.000000	=		0	x	0.000000	=		
	0	x	0.000000	=		0	x	0.000000	=		
Total Standby Load					0.000000	Total Alarm Load					0.000000



Selectable-Output Low Frequency Sounder and Low Frequency Sounder Strobes for Wall Applications

SpectrAlert® Advance audible visible notification products are rich with features guaranteed to cut installation times and maximize profits.

Features

- 520 Hz \pm 10% square wave tone
- Plug-in design with minimal intrusion into the back box
- Tamper-resistant construction
- Field-selectable candela settings on wall units: 135, 150, 177, and 185
- Rotary switch for low frequency sounder tone
- Universal mounting plate for wall units
- Mounting plate shorting spring checks wiring continuity before device installation
- Electrically compatible with legacy SpectrAlert devices
- Compatible with MDL3 sync module
- Listed for ceiling or wall mounting

Agency Listings

SIGNALING



S4011 (sounder)
S5512 (strobes)



3047563

MEA
approved

MEA452-05-E



7135-1653:0223
7125-1653:0224



SPECTRAlert
ADVANCE
from System Sensor

The SpectrAlert Advance series offers the most versatile and easy-to-use line of low frequency sounder and low frequency sounder strobes in the industry. With white and red plastic housings, dual listed for wall and ceiling mounting, SpectrAlert Advance can meet virtually any application requirement.

The wall-mount low frequency sounder, and low frequency sounder strobes were designed to address the NFPA 72 sleeping space requirements that require a low frequency notification appliance that operates within frequency range of 520 Hz \pm 10% and is of a square wave tone. Like the entire SpectrAlert Advance product line they include a variety of features that increase their application versatility while simplifying installation. All devices feature plug-in designs with minimal intrusion into the back box, making installations fast and foolproof while virtually eliminating costly and time-consuming ground faults.

To further simplify installation and protect devices from construction damage, SpectrAlert Advance utilizes a universal mounting plate with an onboard shorting spring, so installers can test wiring continuity before the device is installed.

Installers can also easily adapt devices to a suit a wide range of application requirements using field-selectable candela settings, automatic selection of 12- or 24-volt operation, and a rotary switch for 520 Hz low frequency sounder tones.

SpectrAlert Advance Specifications

Architect/Engineer Specifications

General

SpectrAlert Advance low frequency sounder and low frequency sounder strobes shall mount to a standard 4 × 4 × 1½-inch back box, 4-inch octagon back box, or double-gang back box. Two-wire products shall also mount to a single-gang 2 × 4 × 17/8-inch back box. A universal mounting plate shall be used for mounting products. The notification appliance circuit wiring shall terminate at the universal mounting plate. Also, SpectrAlert Advance products, when used with the Sync•Circuit™ Module accessory, shall be powered from a non-coded notification appliance circuit output and shall operate on a nominal 12 or 24 volts. When used with the Sync•Circuit Module, 12-volt-rated notification appliance circuit outputs shall operate between 8.5 and 17.5 volts; 24-volt-rated notification appliance circuit outputs shall operate between 16.5 and 33 volts. Indoor SpectrAlert Advance products shall operate between 32 and 120 degrees Fahrenheit from a regulated DC or full-wave rectified unfiltered power supply. Low Frequency Sounder strobes shall have field-selectable candela settings including 135, 150, 177, and 185. The field selectable tones will sound within the frequency range of 520 Hz ±10% square wave tone and have a permanent marking on the housing that reads "low frequency sounder".

Low Frequency Sounder

The low frequency sounder shall be a System Sensor SpectrAlert Advance Model _____ listed to UL 464 and shall be approved for fire protective service. The low frequency sounder and the Sync•Circuit™ MDL3 Module accessory, if used, shall be powered from a notification appliance circuit output and shall operate on a nominal 12 or 24 volts (includes fire alarm panels with built in sync). When used with the Sync•Circuit Module MDL3, 12-volt rated notification appliance circuit outputs shall operate between 8.5 and 17.5 volts; 24-volt rated notification appliance circuit outputs shall operate between 16.5 to 33 volts. If the notification appliances are not UL 9th edition listed with the corresponding panel or power supply being used, then refer to the compatibility listing of the panel to determine maximum devices on a circuit. The low frequency sounder has an option to switch between temporal three pattern, non-temporal (continuous) pattern and coded supply within the frequency range of 520Hz ± 10% square wave tone. The low frequency sounder shall operate on a coded or non-coded power supply.

Low Frequency Sounder Strobe Combination

The low frequency sounder strobe shall be a System Sensor SpectrAlert Advance Model _____ listed to UL 1971 and UL 464 and shall be approved for fire protective service. The low frequency sounder strobe shall be wired as a primary-signaling notification appliance and comply with the Americans with Disabilities Act requirements for visible signaling appliances, flashing at 1 Hz over the strobe's entire operating voltage range. The strobe light shall consist of a xenon flash tube and associated lens/reflector system. The sounder shall have an option to switch between a temporal three pattern and a non-temporal (continuous) pattern. These options are set by a multiple position switch. The low frequency sounder on low frequency sounder strobe models shall operate on a non-coded power supply. The field selectable tones will sound within the frequency range of 520 Hz ±10% square wave tone.

Synchronization Module

The module shall be a System Sensor Sync•Circuit model MDL3 listed to UL 464 and shall be approved for fire protective service. The module shall synchronize SpectrAlert strobes at 1 Hz and low frequency sounder at temporal three. Also, while operating the strobes, the module shall silence the low frequency sounder on low frequency sounder strobe models over a single pair of wires. The module shall mount to a 4^{11/16} × 4^{11/16} × 2^{1/8}-inch back box. The module shall also control two Style Y (class B) circuits or one Style Z (class A) circuit. The module shall synchronize multiple zones. Daisy chaining two or more synchronization modules together will synchronize all the zones they control. The module shall not operate on a coded power supply.

Physical/Electrical Specifications

Standard Operating Temperature	32°F to 120°F (0°C to 49°C)
Humidity Range	10 to 93% non-condensing
Frequency Range	520 Hz ± 10%
Strobe Flash Rate	1 flash per second
Nominal Voltage Low Frequency Sounder	Regulated 12 DC/FWR or regulated 24 DC/FWR ¹
Nominal Voltage Range Low Frequency Sounder Strobe	Regulated 24 VDC/FWR ¹
Operating Voltage Range	8 to 17.5 V (12 V nominal) or 16 to 33 V (24 V nominal)
Operating Voltage Range MDL3 Sync Module	8.5 to 17.5 V (12 V nominal) or 16.5 to 33 V (24 V nominal)
Input Terminal Wire Gauge	12 to 18 AWG
Wall-Mount Dimensions (including lens)	6.4 inches L x 4.7 inches W x 2.5 inches D (162 mm L x 119 mm W x 64 mm D)
Sounder Dimensions	5.6 inches L x 4.7 inches W x 1.3 inches D (142 mm L x 119 mm W x 33 mm D)
Low Frequency Sounder/Strobe with Surface Mount Back Box Dimensions (SBBR, SBBW)	6.4 inches L x 4.7 inches W x 4.3 inches D (162 mm L x 120 mm W x 108 mm D)
Low Frequency Sounder with Surface Mount Back Box Dimensions (SBBR, SBBW)	5.7 inches L x 4.8 inches W x 3 inches D (145 mm L x 120 mm W x 76 mm D)

Notes:

1. Full Wave Rectified (FWR) voltage is a non-regulated, time-varying power source that is used on some power supply and panel outputs.

UL Current Draw Data

UL Max. Low Frequency Sounder Current Draw (mA RMS)					
Sound Pattern	dB	8–17.5 Volts		16–33 Volts	
		DC	FWR	DC	FWR
Temporal 3	High	191	262	138	166
Continuous	High	292	384	138	208
Coded	High	292	388	153	205

UL Max. Current Draw (mA RMS), 2-Wire Low Frequency Sounder Strobe, High Candela Range									
DC Input	16–33 Volts				FWR Input	16–33 Volts			
	135	150	177	185		135	150	177	185
Temporal 3	277	292	325	344	Temporal 3	296	309	343	351
Continuous	337	362	387	417	Continuous	393	395	432	433

Low Frequency Sounder Tones and Sound Output Data

Low Frequency Sounder and Low Frequency Sounder Strobe Output (dBA)										
Switch Position	Sound Pattern	8–17.5 Volts		16–33 Volts		24-Volt Nominal				
						Reverberant		Anechoic		
		DC	FWR	DC	FWR	DC	FWR	DC	FWR	
1	Temporal 3	76	76	76	76	76	76	86	86	
2	Continuous	80	80	80	80	80	80	90	90	
3†	Coded	80	80	80	80	80	80	90	90	

† Sounder ratings provided are for continuous voltage as provided by the NAC

SpectrAlert Advance Dimensions

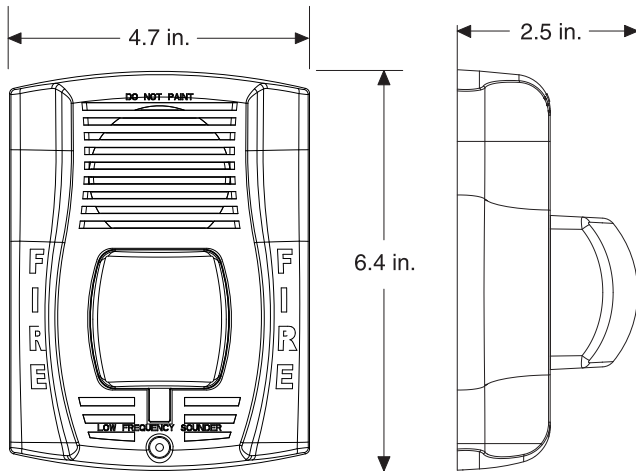

Wall-mount low frequency sounder strobes

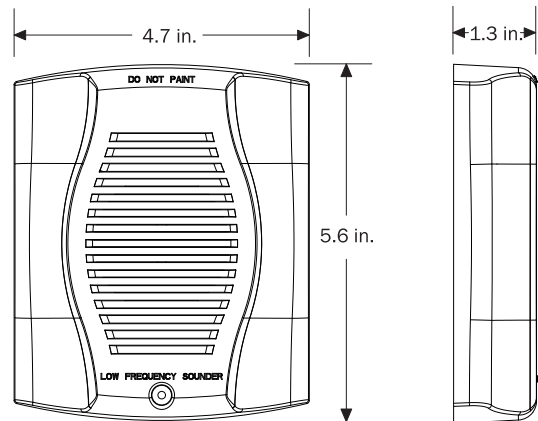

Wall-mount low frequency sounder

SpectrAlert Advance Ordering Information

Model	Description
Wall Low Frequency Sounder Strobes	
P2RH-LF	2-Wire Low Frequency Sounder Strobe, High cd, Red
P2WH-LF	2-Wire Low Frequency Sounder Strobe, High cd, White
Low Frequency Sounders	
HR-LF	Low Frequency Sounder, Red
HW-LF	Low Frequency Sounder, White
Accessories	
SBBR	Surface Mount Back Box, Wall, Red
SBBW	Surface Mount Back Box, Wall, White
TR-HS	Trim Ring, Wall, Red

Notes:

"High cd" refers to strobes that include 135, 150, 177, and 185 candela settings.



3825 Ohio Avenue • St. Charles, IL 60174
 Phone: 800-SENSOR2 • Fax: 630-377-6495
www.systemsensor.com

©2015 System Sensor.
 Product specifications subject to change without notice. Visit systemsensor.com
 for current product information, including the latest version of this data sheet.
 AVDS16404 • 1/15



Outdoor Selectable-Output Horns, Strobes, and Horn Strobes for Wall Applications

SpectrAlert® Advance outdoor audible visible products are rich with features that cut installation times and maximize profits.



Features

- Weatherproof per NEMA 4X, IP56
- Listed to UL 1638 (strobe) and UL 464 (horn)
- Compatible with System Sensor synchronization protocol and legacy SpectrAlert products
- Field-selectable candela settings: 15, 15/75, 30, 75, 95, 110, 115, 135, 150, 177, and 185
- Automatic selection of 12- or 24-volt operation at 15 and 15/75 candela
- Rotary switch for horn tone and three volume selections
- Horn rated at 88+ dBA at 16 volts
- Rated from -40°F to 151°F
- Universal mounting plate with an onboard shorting spring that tests wiring continuity before devices are installed
- Plug-in design with minimal intrusion into the back box
- Tamper-resistant construction
- Listed for ceiling or wall mounting

Agency Listings



S4011 (chimes, horn strobes, horns)
S3593 (outdoor and alert strobes)



3023572



MEA452-05-E



7300-1653-187 (outdoor strobes)
7125-1653-188 (horn strobes,
chime strobes)
7135-1653-189 (horns, chimes)

SpectrAlert Advance offers the broadest line of outdoor horns, strobes, and horn strobes in the industry. With white or red plastic housings, wall or ceiling mounting options, and plain or FIRE-printed devices, SpectrAlert Advance can meet virtually any application requirement, including indoor, outdoor, wet, and dry applications in temperatures from -40°F to 151°F.

Like the entire SpectrAlert Advance line, outdoor horns, strobes, and horn strobes for wall applications include a variety of features that increase application flexibility and simplify installation. First, field-selectable settings, including candela, automatic selection of 12- or 24-volt operation, horn tones, and three volume options enable installers to easily adapt devices to meet requirements.

Next, SpectrAlert Advance devices use a universal mounting plate for both wall and ceiling applications. This mounting plate includes an onboard shorting spring that ensures wiring continuity before devices are installed, so installers can verify proper wiring without mounting the devices and exposing them to potential construction damage. Once the plates are mounted, all SpectrAlert Advance devices utilize a plug-in design with a single captured screw to speed installation and virtually eliminate costly ground faults.

Outdoor devices ship with weatherproof plastic back boxes (metal back boxes are available separately) that accommodate in-and-out wiring for daisy chaining devices. Plastic back boxes feature removable side flanges and improved resistance to saltwater corrosion. Knock-outs located on the back eliminate the need to drill holes for screw-in mounting. Plastic and metal weatherproof back boxes come with 3/4-inch top and bottom conduit entries and 3/4-inch knock-outs at the back. A screw-in NPT plug with an O-ring gasket for a watertight seal is included with each back box.

SpectrAlert Advance Outdoor Horn, Strobe, and Horn Strobe Specifications

Architect/Engineer Specifications

General

SpectrAlert Advance outdoor horns, strobes, and horn strobes shall mount to a weatherproof back box. A universal mounting plate shall be used for mounting ceiling and wall products. The notification appliance circuit wiring shall terminate at the universal mounting plate. Also, SpectrAlert Advance products, when used with the Sync•Circuit™ Module accessory, shall be powered from a non-coded notification appliance circuit output and shall operate on a nominal 12 or 24 volts. When used with the Sync•Circuit Module, 12-volt-rated notification appliance circuit outputs shall operate between 9 and 17.5 volts; 24-volt-rated notification appliance circuit outputs shall operate between 17 and 33 volts. Outdoor SpectrAlert Advance products shall operate between –40 and 151 degrees Fahrenheit from a regulated DC or full-wave rectified unfiltered power supply. Strobes and horn strobes shall have field-selectable candela settings including 15, 15/75, 30, 75, 95, 110, 115, 135, 150, 177, and 185.

Strobe

The strobe shall be a System Sensor SpectrAlert Advance Model _____ listed to UL 1971 and shall be approved for fire protective service. The strobe shall be wired as a primary-signaling notification appliance and comply with the Americans with Disabilities Act requirements for visible signaling appliances, flashing at 1 Hz over the strobe's entire operating voltage range. The strobe light shall consist of a xenon flash tube and associated lens/reflector system. The strobe must be installed with its weatherproof back box in order to remain outdoor approved per UL. The strobe shall be suitable for use in wet environments.

Horn Strobe Combination

The horn strobe shall be a System Sensor SpectrAlert Advance Model _____ listed to UL 1971 and UL 464 and shall be approved for fire protective service. The horn strobe shall be wired as a primary-signaling notification appliance and comply with the Americans with Disabilities Act requirements for visible signaling appliances, flashing at 1 Hz over the strobe's entire operating voltage range. The strobe light shall consist of a xenon flash tube and associated lens/reflector system. The horn shall have three audibility options and an option to switch between a temporal three pattern and a non-temporal (continuous) pattern. These options shall be set by a multiple position switch. On four-wire products, the strobe shall be powered independently of the sounder. The horn or horn strobe models shall operate on a coded or non-coded power supply. The horn strobe must be installed with its weatherproof back box in order to remain outdoor approved per UL. The horn strobe shall be suitable for use in wet environments.

Physical/Electrical Specifications

Operating Temperature	–40°F to 151°F (–40°C to 66°C)
Strobe Flash Rate	1 flash per second
Nominal Voltage	Regulated 12 DC/FWR or regulated 24 DC/FWR ¹
Operating Voltage Range²	8 to 17.5 V (12 V nominal) or 16 to 33 V (24 V nominal)
Input Terminal Wire Gauge	12 to 18 AWG
Wall-Mount Dimensions (including lens)	5.6" L × 4.7" W × 2.5" D (142 mm L × 119 mm W × 64 mm D)
Horn Dimensions	5.6" L × 4.7" W × 1.3" D (142 mm L × 119 mm W × 33 mm D)
Wall-Mount Weatherproof Back Box Dimensions (SA-WBB)	5.7" L × 5.1" W × 2.0" D (145 mm L × 130 mm W × 51 mm D)

Notes:

1. Full Wave Rectified (FWR) voltage is a non-regulated, time-varying power source that is used on some power supply and panel outputs.
2. P, S, PC, and SC products will operate at 12 V nominal only for 15 and 15/75 cd.

UL Current Draw Data

UL Max. Strobe Current Draw (mA RMS)						UL Max. Horn Current Draw (mA RMS)					
	Candela	8–17.5 Volts		16–33 Volts		Sound Pattern	dB	8–17.5 Volts		16–33 Volts	
		DC	FWR	DC	FWR			DC	FWR	DC	FWR
Standard Candela Range	15	123	128	66	71	Temporal	High	57	55	69	75
	15/75	142	148	77	81	Temporal	Medium	44	49	58	69
	30	NA	NA	94	96	Temporal	Low	38	44	44	48
	75	NA	NA	158	153	Non-Temporal	High	57	56	69	75
	95	NA	NA	181	176	Non-Temporal	Medium	42	50	60	69
	110	NA	NA	202	195	Non-Temporal	Low	41	44	50	50
	115	NA	NA	210	205	Coded	High	57	55	69	75
High Candela Range	135	NA	NA	228	207	Coded	Medium	44	51	56	69
	150	NA	NA	246	220	Coded	Low	40	46	52	50
	177	NA	NA	281	251						
	185	NA	NA	286	258						

UL Max. Current Draw (mA RMS), 2-Wire Horn Strobe, Standard Candela Range (15–115 cd)									
DC Input	8–17.5 Volts			16–33 Volts					
	15	15/75	15	15/75	30	75	95	110	115
Temporal High	137	147	79	90	107	176	194	212	218
Temporal Medium	132	144	69	80	97	157	182	201	210
Temporal Low	132	143	66	77	93	154	179	198	207
Non-Temporal High	141	152	91	100	116	176	201	221	229
Non-Temporal Medium	133	145	75	85	102	163	187	207	216
Non-Temporal Low	131	144	68	79	96	156	182	201	210
FWR Input									
Temporal High	136	155	88	97	112	168	190	210	218
Temporal Medium	129	152	78	88	103	160	184	202	206
Temporal Low	129	151	76	86	101	160	184	194	201
Non-Temporal High	142	161	103	112	126	181	203	221	229
Non-Temporal Medium	134	155	85	95	110	166	189	208	216
Non-Temporal Low	132	154	80	90	105	161	184	202	211

UL Max. Current Draw (mA RMS), 2-Wire Horn Strobe, High Candela Range (135–185 cd)									
DC Input	16–33 Volts				FWR Input	16–33 Volts			
	135	150	177	185		135	150	177	185
Temporal High	245	259	290	297	Temporal High	215	231	258	265
Temporal Medium	235	253	288	297	Temporal Medium	209	224	250	258
Temporal Low	232	251	282	292	Temporal Low	207	221	248	256
Non-Temporal High	255	270	303	309	Non-Temporal High	233	248	275	281
Non-Temporal Medium	242	259	293	299	Non-Temporal Medium	219	232	262	267
Non-Temporal Low	238	254	291	295	Non-Temporal Low	214	229	256	262

Candela Derating

For K series products used at low temperatures, listed candela ratings must be reduced in accordance with this table.

Strobe Output (cd)	
Listed Candela	Candela rating at –40°F
15	Do not use below 32°F
15/75	
30	
75	
95	44
110	70
115	110
135	115
150	135
177	150
185	177

Horn Tones and Sound Output Data

Horn and Horn Strobe Output (dBA)											
Switch Position	Sound Pattern	dB	8–17.5 Volts		16–33 Volts		24-Volt Nominal				
			DC	FWR	DC	FWR	Reverberant		Anechoic		
			DC	FWR	DC	FWR	DC	FWR	DC	FWR	
1	Temporal	High	78	78	84	84	88	88	99	98	
2	Temporal	Medium	74	74	80	80	86	86	96	96	
3	Temporal	Low	71	73	76	76	83	80	94	89	
4	Non-Temporal	High	82	82	88	88	93	92	100	100	
5	Non-Temporal	Medium	78	78	85	85	90	90	98	98	
6	Non-Temporal	Low	75	75	81	81	88	84	96	92	
7†	Coded	High	82	82	88	88	93	92	101	101	
8†	Coded	Medium	78	78	85	85	90	90	97	98	
9†	Coded	Low	75	75	81	81	88	85	96	92	

†Settings 7, 8, and 9 are not available on 2-wire horn strobe.

SpectrAlert Advance Diagrams

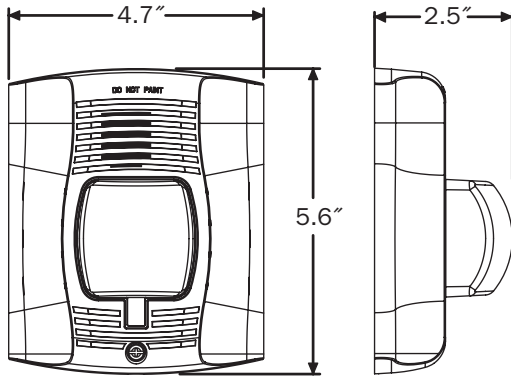

Wall-Mount Horn Strobes

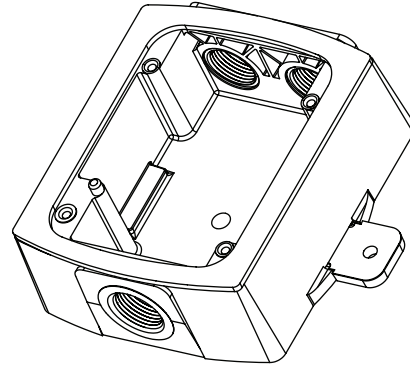

Wall Plastic Weatherproof Back Box

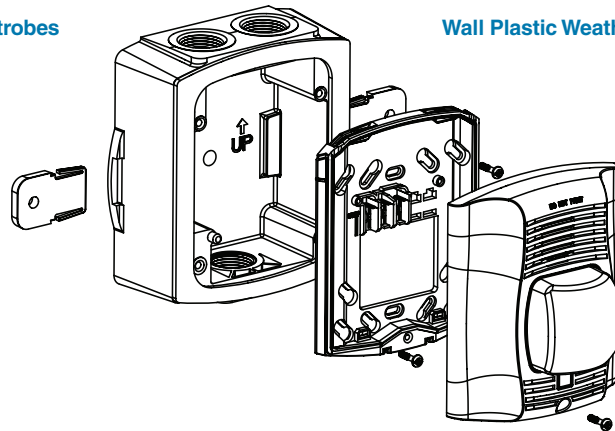

Wall-Mount Horn Strobe with Plastic Weatherproof Back Box

SpectrAlert Advance Ordering Information

Model	Description
Wall Horn Strobes	
P2RK*†	2-Wire Horn Strobe, Standard cd, Red, Outdoor (includes plastic weatherproof back box)
P2RHK*†	2-Wire Horn Strobe, High cd, Red, Outdoor (includes plastic weatherproof back box)
P2WK*†	2-Wire Horn Strobe, Standard cd, White, Outdoor (includes plastic weatherproof back box)
P2WHK*†	2-Wire Horn Strobe, High cd, White, Outdoor (includes plastic weatherproof back box)
P4RK†	4-Wire Horn Strobe, Standard cd, Red, Outdoor (includes plastic weatherproof back box)
P4WK	4-Wire Horn Strobe, Standard cd, White, Outdoor (includes plastic weatherproof back box)
P2RHK-120	2-Wire Horn Strobe, High cd, Red, Outdoor, 120 V (includes plastic weatherproof back box)
Wall Strobes	
SRK*†	Strobe, Standard cd, Red, Outdoor (includes plastic weatherproof back box)
SRHK*†	Strobe, High cd, Red, Outdoor (includes plastic weatherproof back box)
SWK*†	Strobe, Standard cd, White, Outdoor (includes plastic weatherproof back box)
SWHK*†	Strobe, High cd, White, Outdoor (includes plastic weatherproof back box)
Horns	
HRK†	Horn, Red, Outdoor (includes plastic weatherproof back box)
Accessories	
SA-WBB	Red, Metal Weatherproof Back Box
SA-WBBW	White, Metal Weatherproof Back Box

Notes:

* Add "-P" to model number for plain housing (no "FIRE" marking on cover), e.g., P2RK-P.

† Add "-R" to model number for weatherproof replacement device (no back box included), only for use with weatherproof outdoor flush mounting plate, WTP and WTPW. "Standard cd" refers to strobes that include 15, 15/75, 30, 75, 95, 110, and 115 candela settings. "High cd" refers to strobes that include 135, 150, 177, and 185 candela settings. **When replacing standard outdoor units both the device and back box must be replaced.**



3825 Ohio Avenue • St. Charles, IL 60174
Phone: 800-SENSOR2 • Fax: 630-377-6495

©2012 System Sensor.
Product specifications subject to change without notice. Visit systemsensor.com
for current product information, including the latest version of this data sheet.
AVDS01201 • 3/12



Indoor Selectable-Output Horns, Strobes, and Horn Strobes for Wall Applications

System Sensor L-Series audible visible notification products are rich with features guaranteed to cut installation times and maximize profits with lower current draw and modern aesthetics.

Features

- Updated Modern Aesthetics
- Small profile devices for Horns and Horn Strobes
- Plug-in design with minimal intrusion into the back box
- Tamper-resistant construction
- Automatic selection of 12- or 24-volt operation at 15 and 30 candela
- Field-selectable candela settings on wall units: 15, 30, 75, 95, 110, 135, and 185
- Horn rated at 88+ dBA at 16 volts
- Rotary switch for horn tone and two volume selections
- Mounting plate for all standard and all compact wall units
- Mounting plate shorting spring checks wiring continuity before device installation
- Electrically Compatible with legacy SpectrAlert and SpectAlert Advance devices
- Compatible with MDL3 sync module
- Listed for wall mounting only

Agency Listings



The System Sensor L-Series offers the most versatile and easy-to-use line of horns, strobes, and horn strobes in the industry with lower current draws and modern aesthetics. With white and red plastic housings, standard and compact devices, and plain, FIRE, and FUEGO-printed devices, System Sensor L-Series can meet virtually any application requirement.

The L-Series line of wall-mount horns, strobes, and horn strobes include a variety of features that increase their application versatility while simplifying installation. All devices feature plug-in designs with minimal intrusion into the back box, making installations fast and foolproof while virtually eliminating costly and time-consuming ground faults.

To further simplify installation and protect devices from construction damage, the L-Series utilizes a universal mounting plate for all models with an onboard shorting spring, so installers can test wiring continuity before the device is installed.

Installers can also easily adapt devices to a suit a wide range of application requirements using field-selectable candela settings, automatic selection of 12- or 24-volt operation, and a rotary switch for horn tones with two volume selections.

L-Series Specifications

Architect/Engineer Specifications

General

L-Series standard horns, strobes, and horn strobes shall mount to a standard 2 x 4 x 1 7/8-inch back box, 4 x 4 x 1 1/2-inch back box, 4-inch octagon back box, or double-gang back box. L-Series compact products shall mount to a single-gang 2 x 4 x 1 7/8-inch back box. A universal mounting plate shall be used for mounting ceiling and wall products for all standard models and a separate universal mounting plate shall be used for mounting wall compact models. The notification appliance circuit wiring shall terminate at the universal mounting plate. Also, L-Series products, when used with the Sync•Circuit™ Module accessory, shall be powered from a non-coded notification appliance circuit output and shall operate on a nominal 12 or 24 volts. When used with the Sync•Circuit Module, 12-volt-rated notification appliance circuit outputs shall operate between 8.5 and 17.5 volts; 24-volt-rated notification appliance circuit outputs shall operate between 16.5 and 33 volts. Indoor L-Series products shall operate between 32 and 120 degrees Fahrenheit from a regulated DC or full-wave rectified unfiltered power supply. Strobes and horn strobes shall have field-selectable candela settings including 15, 30, 75, 95, 110, 135, and 185.

Strobe

The strobe shall be a System Sensor L-Series Model _____ listed to UL 1971 and shall be approved for fire protective service. The strobe shall be wired as a primary-signaling notification appliance and comply with the Americans with Disabilities Act requirements for visible signaling appliances, flashing at 1 Hz over the strobe's entire operating voltage range. The strobe light shall consist of a xenon flash tube and associated lens/reflector system.

Horn Strobe Combination

The horn strobe shall be a System Sensor L-Series Model _____ listed to UL 1971 and UL 464 and shall be approved for fire protective service. The horn strobe shall be wired as a primary-signaling notification appliance and comply with the Americans with Disabilities Act requirements for visible signaling appliances, flashing at 1 Hz over the strobe's entire operating voltage range. The strobe light shall consist of a xenon flash tube and associated lens/reflector system. The horn shall have two audibility options and an option to switch between a temporal three pattern and a non-temporal (continuous) pattern. These options are set by a multiple position switch. The horn on horn strobe models shall operate on a coded or non-coded power supply.

Synchronization Module

The module shall be a System Sensor Sync•Circuit model MDL3 listed to UL 464 and shall be approved for fire protective service. The module shall synchronize SpectraAlert strobes at 1 Hz and horns at temporal three. Also, while operating the strobes, the module shall silence the horns on horn strobe models over a single pair of wires. The module shall mount to a 4 1/16 x 4 1/16 x 2 1/8-inch back box. The module shall also control two Style Y (class B) circuits or one Style Z (class A) circuit. The module shall synchronize multiple zones. Daisy chaining two or more synchronization modules together will synchronize all the zones they control. The module shall not operate on a coded power supply.

Physical/Electrical Specifications

Standard Operating Temperature	32°F to 120°F (0°C to 49°C)
Humidity Range	10 to 93% non-condensing
Strobe Flash Rate	1 flash per second
Nominal Voltage	Regulated 12 DC or regulated 24 DC/FWR ^{1,2}
Operating Voltage Range	8 to 17.5 V (12 V nominal) or 16 to 33 V (24 V nominal)
Operating Voltage Range MDL3 Sync Module	8.5 to 17.5 V (12 V nominal) or 16.5 to 33 V (24 V nominal)
Input Terminal Wire Gauge	12 to 18 AWG
Wall-Mount Dimensions (including lens)	5.6" L x 4.7" W x 1.91" D (143 mm L x 119 mm W x 49 mm D)
Compact Wall-Mount Dimensions (including lens)	5.26" L x 3.46" W x 1.91" D (133 mm L x 88 mm W x 49 mm D)
Horn Dimensions	5.6" L x 4.7" W x 1.25" D (143 mm L x 119 mm W x 32 mm D)
Compact Horn Dimensions	5.25" L x 3.45" W x 1.25" D (133mm L x 88mm W x 32mm D)

1. Full Wave Rectified (FWR) voltage is a non-regulated, time-varying power source that is used on some power supply and panel outputs.

2. Strobe products will operate at 12 V nominal only for 15 cd and 30 cd.

UL Current Draw Data

UL Max. Strobe Current Draw (mA RMS)				
Candela Range	Candela	8-17.5 Volts		
		DC	16-33 Volts DC	FWR
Candela Range	15	88	43	60
	30	143	63	83
	75	N/A	107	136
	95	N/A	121	155
	110	N/A	148	179
	135	N/A	172	209
	185	N/A	222	257

UL Max. Horn Current Draw (mA RMS)				
Sound Pattern	dB	8-17.5 Volts		
		DC	16-33 Volts DC	FWR
Temporal	High	39	44	54
Temporal	Low	28	32	54
Non-Temporal	High	43	47	54
Non-Temporal	Low	29	32	54
3.1 KHz Temporal	High	39	41	54
3.1 KHz Temporal	Low	29	32	54
3.1 KHz Non-Temporal	High	42	43	54
3.1 KHz Non-Temporal	Low	28	29	54
Coded	High	43	47	54
3.1 KHz Coded	High	42	43	54

UL Max. Current Draw (mA RMS), 2-Wire Horn Strobe, Candela Range (15-115 cd)										
DC Input	8-17.5 Volts		16-33 Volts							
	15cd	30cd	15cd	30cd	75cd	95cd	110cd	135cd	185cd	
Temporal High	98	158	54	74	121	142	162	196	245	
Temporal Low	93	154	44	65	111	133	157	184	235	
Non-Temporal High	106	166	73	94	139	160	182	211	262	
Non-Temporal Low	93	156	51	71	119	139	162	190	239	
3.1K Temporal High	93	156	53	73	119	140	164	190	242	
3.1K Temporal Low	91	154	45	66	112	133	160	185	235	
3.1K Non-Temporal High	99	162	69	90	135	157	175	208	261	
3.1K Non-Temporal Low	93	156	52	72	119	138	162	192	242	
16-33 Volts										
FWR Input	15cd	30cd	75cd	95cd	110cd	135cd	185cd			
Temporal High	83	107	156	177	198	234	287			
Temporal Low	68	91	145	165	185	223	271			
Non-Temporal High	111	135	185	207	230	264	316			
Non-Temporal Low	79	104	157	175	197	235	283			
3.1K Temporal High	81	105	155	177	196	234	284			
3.1K Temporal Low	68	90	145	166	186	222	276			
3.1K Non-Temporal High	104	131	177	204	230	264	326			
3.1K Non-Temporal Low	77	102	156	177	199	234	291			

Horn Tones and Sound Output Data

Horn and Horn Strobe Output (dBA)					
Switch Position	Sound Pattern	dB	8-17.5 Volts		16-33 Volts
			DC	DC	FWR
1	Temporal	High	84	89	89
2	Temporal	Low	75	83	83
3	Non-Temporal	High	85	90	90
4	Non-Temporal	Low	76	84	84
5	3.1 KHz Temporal	High	83	88	88
6	3.1 KHz Temporal	Low	76	82	82
7	3.1 KHz Non-Temporal	High	84	89	89
8	3.1 KHz Non-Temporal	Low	77	83	83
9*	Coded	High	85	90	90
10*	3.1 KHz Coded	High	84	89	89

* Settings 9 and 10 are not available on the 2-wire horn strobes.

L-Series Dimensions

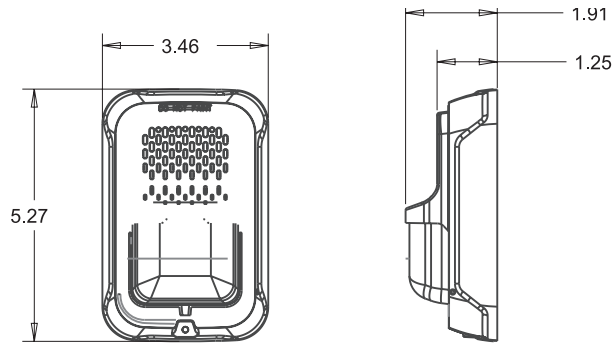

Compact Strobe / Horn Strobe

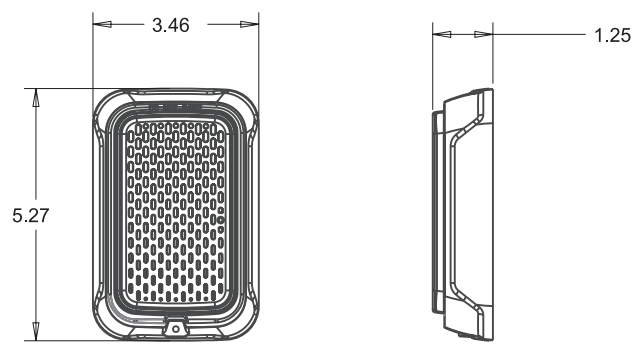

Compact Horn

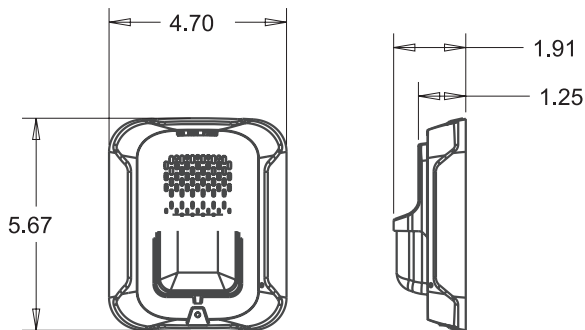

Strobe / Horn Strobe

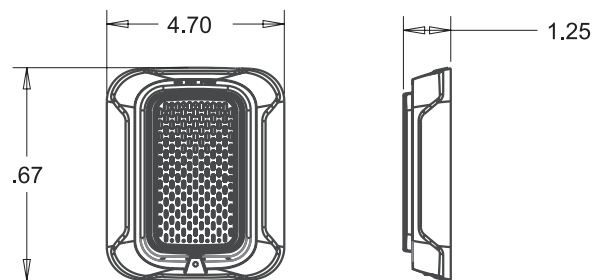

Horn

L-Series Ordering Information

Model	Description
Wall Horn Strobes	
P2RL	2-Wire, Horn Strobe, Red
P2WL	2-Wire, Horn Strobe, White
P2GRL	2-Wire, Compact Horn Strobe, Red
P2GWL	2-Wire, Compact Horn Strobe, White
P2RL-P	2-Wire, Horn Strobe, Red, Plain
P2WL-P	2-Wire, Horn Strobe, White, Plain
P2RL-SP	2-Wire, Horn Strobe, Red, FUEGO
P2WL-SP	2-Wire, Horn Strobe, White, FUEGO
Wall Strobes	
SRL	Strobe, Red
SWL	Strobe, White
SGRL	Compact Strobe, Red
SGWL	Compact Strobe, White
SRL-P	Strobe, Red, Plain
SWL-P	Strobe, White, Plain
SRL-SP	Strobe, Red, FUEGO
SWL-CLR-ALERT	Strobe, White, ALERT

Model	Description
Horns	
HRL	Horn, Red
HWL	Horn, White
HGRL	Compact Horn, Red
HGWL	Compact Horn, White
Accessories	
TR-2	Universal Wall Trim Ring Red
TR-2W	Universal Wall Trim Ring White
SBBRL	Wall Surface Mount Back Box, Red
SBBWL	Wall Surface Mount Back Box, White
SBBGRL	Compact Wall Surface Mount Back Box, Red
SBBGWL	Compact Wall Surface Mount Back Box, White

Notes:

All -P models have a plain housing (no "FIRE" marking on cover)
 All -SP models have "FUEGO" marking on cover
 All -ALERT models have "ALERT" marking on cover



3825 Ohio Avenue • St. Charles, IL 60174
 Phone: 800-SENSOR2 • Fax: 630-377-6495
www.systemsensor.com

©2017 System Sensor.
 Product specifications subject to change without notice. Visit www.systemsensor.com
 for current product information, including the latest version of this data sheet.
 AVDS86503 • 03/17

SD365(A) Series

Addressable Photoelectric Detectors



Addressable Devices

General

The Fire-Lite SD365(A), SD365T(A), and SD365R(A) Series addressable plug-in photoelectric smoke detectors are designed for both performance and aesthetics. A new modern, sleek, contemporary design and enhanced optical sensing chamber is engineered to sense smoke produced by a wide range of combustion sources in accordance with more stringent code standards.

Exclusively for use with Fire-Lite's addressable fire alarm control panels, the SD365(A) Series point ID capability allows each detector's address to be set with rotary, decimal address switches, providing exact detector location for emergency personnel to quickly locate a fire during its early stages, potentially saving precious rescue time while also reducing property damage. Two LEDs on each sensor light to provide a local, visible sensor indication.

The SD365(A) Series also offers 135°F (57°C) fixed temperature thermal sensing on the SD365T(A) and a remote test capable detector on the SD365R(A) for use with DNR(A)/DNRW duct smoke detector housings.

Features

SLC LOOP

- Two-wire loop connection.
- Unit uses base for wiring.

ADDRESSING

- Addressable by device.
- Rotary, decimal addressing: *Please refer to the Fire-Lite panel manuals for device capacity.*

ARCHITECTURE

- New modern profile for improved aesthetics.
- Unique single-source design to respond quickly and dependably to a broad range of fires.
- Integral communications and built-in type identification.
- Built-in tamper-resistant feature.
- Removable cover and insect-resistant screen for simple field cleaning.

OPERATION

- Designed to meet UL 268 7th Edition.
- Factory preset at 1.5% nominal sensitivity for panel alarm threshold level.
- Visible LED "blinks" when the unit is addressed (communicating with the fire panel) and latches on in alarm.
- Low standby current.

MECHANICALS

- Sealed against back pressure.
- Mounts to: single-gang box, 3.5" (8.89 cm) or 4.0" (10.16 cm) octagonal box, or 4.0" (10.16 cm) square electrical box (*with or without a mud ring - not included*).

OPTIONS

- Remote LED output connection, RA100Z.



SD365

Installation

SD365(A) series plug-in detectors use a detachable mounting base to simplify installation, service and maintenance.

Mount base (all base types) on an electrical backbox which is at least 1.5" (3.81 cm) deep. For a chart of compatible junction boxes, see *DF-60059*.

NOTE: *Because of the inherent supervision provided by the SLC loop, end-of-line resistors are not required. Wiring "T-taps" or branches are permitted for Style 4 (Class B) wiring. SD365R(A) mounts in a D355PL(A) or DNR(A) /DNRW duct detector housing.*

Operation

Each SD365(A) Series detector uses one possible addresses on the Fire-lite Signaling Line Circuit (SLC). It responds to regular polls from the system and reports its type and status.

Detector Sensitivity Test

Each detector can have its sensitivity tested (required per NFPA 72, Chapter 14 on *Inspection, Testing and Maintenance*) when installed/connected to an ES-50X or ES-200X addressable fire alarm control panel. The results of the sensitivity test can be printed off the for record keeping.

Specification

Voltage range: 15 – 32 VDC (peak).

Standby current: 200 µA @ 24 VDC.

Max current: 4.5 mA @ 24 VDC (latched "ON").

Air velocity: 4,000 ft./min. (20 m/sec.) maximum.

Sensitivity: UL Applications: 0.5% to 4.0% per foot obscuration

Size: 2.0" (5.3 cm) high; base determines diameter.

– B300-6: 6.1" (15.6 cm) diameter.

– B501: 4" (10.2 cm) diameter.

For a complete list of detector bases see *DN-60981*.

Shipping weight: 3.4 oz. (95 g).

Operating temperature range:

- SD365(A): 0°C to 50°C (32°F to 122°F);
- SD365T(A): 0°C to 38°C (32°F to 100°F).
- SD365R(A): installed in a DNR(A)/DNRW -20°C to 70°C (-4°F to 158°F).

Relative humidity: 10%-93%, non-condensing.

Listings

Listings and approvals below apply to the SD365 Series detectors. In some cases, certain detectors may not be listed by certain approval agencies, or listing may be in process. Consult factory for latest listing status.

- UL/ULC Listed: S1059
- CSFM: 7272-0075-0502
- FM Approved

Product Line Information

NOTE: Detectors must be mounted to one of the Intelligent Bases listed below.

NOTE: "IV" suffix indicates LiteSpeed® and CLIP device.

NOTE: "A" suffix indicates Canadian version.

SD365(A): White, Addressable photoelectric detector; B300-6 base included. LiteSpeed only.

SD365(A)-IV: Ivory, Addressable photoelectric detector; B300-6 base included.

SD365T(A): White, Same as SD365 but with thermal element; B300-6 base included. LiteSpeed only.

SD365T(A)-IV: Ivory, Same as SD365 but with thermal element; B300-6 base included.

SD365R(A): White, Remote test capable addressable photoelectric detector for use with DNR(A)/DNRW. LiteSpeed only.

SD365R(A)-IV: Ivory, Remote test capable addressable photoelectric detector; for use with DNR(A)/DNRW.

INTELLIGENT BASES

NOTE: For details on intelligent bases, see DN-60981.

B300-6: White, 6" base, standard flanged low-profile mounting base. (CSFM: 7300-1653:0109 Pending)

B300-6-IV: Ivory, 6" base, standard flanged low-profile mounting base. (CSFM: 7300-1653:0109 Pending)

B300A-6: Same as B300-6, ULC listed.

B300A-6-IV: Ivory, 6" standard flanged low-profile mounting base, ULC listed.

B300-6-BP: Bulk pack of B300-6, package contains 10

B501-WHITE: White, 4" standard European flangeless mounting base. UL/ULC listed. (CSFM: 7300-1653:0109 Pending)

B501-BL: Black, 4" standard European flangeless mounting base. UL/ULC listed. (CSFM: 7300-1653:0109 Pending)

B501-IV: Ivory color, 4" standard European flangeless mounting base. UL/ULC listed. (CSFM: 7300-1653:0109 Pending)

B501-WHITE-BP: Bulk pack of B501-WHITE contains 10.

B224RB-WH: White, relay base. (CSFM: 7300-1653:0216 Pending)

B224RB-IV: Ivory, relay base. (CSFM: 7300-1653:0216 Pending)

B224RBA-WH: White, relay base, ULC listing.

B224RBA-IV: Ivory, relay base, ULC listing.

B224BI-WH: White, *isolator* detector base. (CSFM: 7300-1653:0216 Pending)

B224BI-IV: Ivory *isolator* detector base. (CSFM: 7300-1653:0216 Pending)

B224BIA-WH: White, *isolator* detector base, ULC listing.

B224BIA-IV: Ivory *isolator* detector base, ULC listing.

B200S-WH: White, Intelligent addressable sounder base capable of producing sound output in high or low volume with ANSI Temporal 3, ANSI Temporal 4, continuous tone, marching tone, and custom tone. Uses FlashScan protocol. (CSFM: 7300-1653:0213 Pending)

B200S-IV: Ivory, Intelligent addressable sounder base capable of producing sound output in high or low volume with ANSI Temporal 3, ANSI Temporal 4, continuous tone, marching tone, and custom tone. Uses FlashScan protocol. (CSFM: 7300-1653:0213 Pending)

B200SA-WH: Same as B200S-WH, ULC listing.

B200SA-IV: Same as B200S-IV, ULC listing.

B200SCOA-WH: White, Intelligent, programmable sounder base in English/French (required in Canada for ULC applications with CO Series detector applications).

B200SCOA-IV: Ivory Intelligent, programmable sounder base in English/French (required in Canada for ULC applications with CO Series detector applications, ULC listing).

B200S-LF-WH: White, Low Frequency Intelligent, programmable sounder base. Produces a fundamental frequency of 520 Hz +/- 10% with a square wave or its equivalent; designed to meet the NFPA 72 sleeping space requirement. (CSFM: 7300-1653:0238 Pending)

B200S-LF-IV: Ivory, Low Frequency Intelligent, programmable sounder base. Produces a fundamental frequency of 520 Hz +/- 10% with a square wave or its equivalent; designed to meet the NFPA 72 sleeping space requirement. (CSFM: 7300-1653:0238 Pending)

B200SR-WH: White, Intelligent sounder base capable of producing sound output with ANSI Temporal 3 or continuous tone. Intended for retrofit applications. (CSFM: 7300-1653:0213 Pending)

B200SR-IV: Ivory, Intelligent sounder base capable of producing sound output with ANSI Temporal 3 or continuous tone. Intended for retrofit applications. (CSFM: 7300-1653:0213 Pending)

B200SRA-WH: Same as B200SR-WH with, ULC listing.

B200SRA-IV: Same as B200SR-IV in Ivory color, ULC listing.

B200SR-LF-WH: White, Low Frequency Intelligent, programmable sounder base. Produces a fundamental frequency of 520 Hz +/- 10% with a square wave or its equivalent; designed to meet the NFPA 72 sleeping space requirement. Intended for retrofit applications. (CSFM: 7300-1653:0238 Pending)

B200SR-LF-IV: Ivory, Low Frequency Intelligent, programmable sounder base. Produces a fundamental frequency of 520 Hz +/- 10% with a square wave or its equivalent; designed to meet the NFPA 72 sleeping space requirement. Intended for retrofit applications. (CSFM: 7300-1653:0238 Pending)

MOUNTING KITS AND ACCESSORIES

TR300: White, replacement flange for B210LP(A) base.

TR300-IV: Ivory, replacement flange for B210LP(A) base.

RA100Z(A): Remote LED annunciator. 3 – 32 VDC. Mounts to a U.S. single-gang electrical box. For use with B501(A) and B300-6(A).

M02-04-00: Test magnet.

M02-09-00: Test magnet with telescoping handle.

CK300: Color Kit (includes cover and trim ring), white, 10-pack.

CK300-IV: Color Kit (includes cover and trim ring), ivory, 10-pack.

CK300-BL: Color Kit (includes cover and trim ring), black, 10-pack.

FireLite® Alarms is a registered trademark of Honeywell International Inc.
©2018 by Honeywell International Inc. All rights reserved. Unauthorized use of this document is strictly prohibited.



This document is not intended to be used for installation purposes.
We try to keep our product information up-to-date and accurate.
We cannot cover all specific applications or anticipate all requirements.
All specifications are subject to change without notice.

For more information, contact Fire•Lite Alarms. Phone: (800) 627-3473, FAX: (877) 699-4105.
www.firelite.com