

GENERAL NOTES:

1. ACCESS TO BUILDING FOR PERSONS IN WHEELCHAIRS IS DESIGNED BY AND FIELD BUILT BY OTHERS AND SUBJECT TO LOCAL JURISDICTION APPROVAL. THE PRIMARY ENTRANCE MUST BE ACCESSIBLE.
2. ALL DOORS SHALL BE OPENABLE FROM THE EGRESS SIDE WITHOUT THE USE OF A KEY, TOOL, SPECIAL KNOWLEDGE OR EFFORT. MANUALLY OPERATED FLUSH BOLTS OR SURFACE BOLTS SHALL NOT BE USED.
3. ALL GLAZING WITHIN A 24 INCH ARC OF DOORS, WHOSE BOTTOM EDGE IS LESS THAN 60 INCHES ABOVE THE FLOOR, AND ALL GLAZING IN DOORS SHALL BE SAFETY, TEMPERED OR ACRYLIC PLASTIC SHEET.
4. ALL STEEL STRAPS REFERENCED ON FLOOR PLAN SHALL BE 1.5 INCH x 26 GA. WITH 7 - 15 GA. x 7/16 INCH CROWN x 1 INCH STAPLES EACH END OF STRAP OR EQUIVALENT FROM RIDGE BEAM TO COLUMN, AND COLUMN TO FLOOR.
5. PORTABLE FIRE EXTINGUISHER PER N.F.P.A. - 10 INSTALLED BY OTHERS ON SITE, AND SUBJECT TO LOCAL JURISDICTION.
6. PROVISIONS FOR EXIT DISCHARGE LIGHTING ARE THE RESPONSIBILITY OF THE BUILDING OWNER AND SUBJECT TO LOCAL JURISDICTION APPROVAL WHEN NOT SHOWN ON THE FLOOR PLAN (INCLUDING EMERGENCY LIGHTING, WHEN REQUIRED).
7. WHEN LOW SIDES OF ROOF PROVIDE LESS THAN 6" OF OVERHANG, GUTTERS AND DOWN SPOUTS SHALL BE SITE INSTALLED, DESIGNED BY OTHERS, SUBJECT TO LOCAL JURISDICTION APPROVAL.
8. IN WIND-BORNE DEBRIS REGIONS, EXTERIOR GLAZING SHALL BE IMPACT RESISTANT OR PROTECTED WITH AN IMPACT RESISTANT COVERING MEETING THE REQUIREMENTS OF AN APPROVED IMPACT RESISTANT STANDARD, OR ASTM E1996. WIND-BORNE DEBRIS REGIONS ARE DESIGNATED IN SECTION 1609 OF THE NCBC.
9. WINDOWS AND DOORS MUST BE CERTIFIED FOR COMPLIANCE WITH THE WIND DESIGN PRESSURE FOR COMPONENTS AND CLADDING.
10. DESIGNED TO COMPLY WITH NC CLIMATE ZONE 3A.

ELECTRICAL NOTES:

1. ALL CIRCUITS AND EQUIPMENT SHALL BE GROUNDED IN ACCORDANCE WITH THE APPROPRIATE ARTICLES OF THE NATIONAL ELECTRICAL CODE (NEC).
2. WHEN LIGHT FIXTURES ARE INSTALLED IN CLOSETS THEY SHALL BE SURFACE MOUNTED OR RECESSED. INCANDESCENT FIXTURES SHALL HAVE COMPLETELY ENCLOSED LAMPS. SURFACE MOUNTED INCANDESCENT FIXTURES SHALL HAVE A MINIMUM CLEARANCE OF 12 INCHES AND ALL OTHER FIXTURES SHALL HAVE A MINIMUM CLEARANCE OF 6 INCHES FROM "CLOSET STORAGE SPACE" AS DEFINED BY NEC ARTICLE 410.2.
3. WHEN WATER HEATERS ARE INSTALLED THEY SHALL BE PROVIDED WITH READILY ACCESSIBLE DISCONNECTS ADJACENT TO THE WATER HEATERS SERVED. THE BRANCH CIRCUIT SWITCH OR CIRCUIT BREAKER SHALL BE PERMITTED TO SERVE AS THE DISCONNECTING MEANS ONLY WHERE THE SWITCH OR CIRCUIT BREAKER IS WITHIN SIGHT FROM THE WATER HEATER OR IS CAPABLE OF BEING LOCKED IN THE OPEN POSITION.
4. HVAC EQUIPMENT SHALL BE PROVIDED WITH READILY ACCESSIBLE DISCONNECTS ADJACENT TO THE EQUIPMENT SERVED. A UNIT SWITCH WITH A MARKED "OFF" POSITION THAT IS A PART OF THE HVAC EQUIPMENT AND DISCONNECTS ALL UNGROUNDED CONDUCTORS SHALL BE PERMITTED AS THE DISCONNECTING MEANS WHERE OTHER DISCONNECTING MEANS ARE ALSO PROVIDED BY A READILY ACCESSIBLE CIRCUIT BREAKER.
5. PRIOR TO ENERGIZING THE ELECTRICAL SYSTEM THE INTERRUPTING RATING OF THE MAIN BREAKER MUST BE DESIGNED AND VERIFIED AS BEING IN COMPLIANCE WITH ARTICLES 110.9 & 110.10 OF THE NEC BY LOCAL ELECTRICAL CONSULTANT.
6. THE MAIN ELECTRICAL PANEL AND FEEDERS ARE DESIGNED BY OTHERS, SITE INSTALLED AND SUBJECT TO LOCAL JURISDICTION APPROVAL.
7. ALL CIRCUITS CROSSING OVER MODULE MATING LINE(S) SHALL BE SITE CONNECTED WITH APPROVED ACCESSIBLE JUNCTION BOXES, OR CABLE CONNECTORS.
8. ALL RECEPTACLES INSTALLED IN WET LOCATIONS (EXTERIOR) SHALL BE IN WEATHER PROOF (WP) ENCLOSURES, THE INTEGRITY OF WHICH IS NOT AFFECTED WHEN AN ATTACHMENT PLUG CAP IS INSERTED OR REMOVED. 15 & 20 AMP EXTERIOR RECEPTS SHALL BE LISTED AS WEATHER RESISTANT.
9. EXTERIOR LIGHTS NOT INTENDED FOR 24 HOUR USE SHALL BE CONNECTED TO A PHOTOCCELL OR TIMER.

MECHANICAL NOTES:

1. ALL SUPPLY AIR REGISTERS SHALL BE 10 INCHES x 10 INCHES ADJUSTABLE WITH 8 INCHES x 18 INCHES (INSIDE) OVERHEAD FIBERGLASS DUCT, UNLESS OTHERWISE SPECIFIED. DUCTS IN UNCONDITIONED SPACES SHALL HAVE R-6 MINIMUM INSULATION EXCEPT DUCTS EXPOSED TO VENTILATED ATTICS AND CRAWL SPACES SHALL HAVE R-8 INSULATION.
2. INTERIOR DOORS SHALL BE UNDERCUT 1.5 INCHES ABOVE FINISHED FLOOR FOR AIR RETURN AND/OR AS NOTED ON FLOOR PLAN (FOR UNRATED DOORS)
3. HVAC EQUIPMENT SHALL BE EQUIPPED W/OUTSIDE FRESH AIR INTAKES PROVIDING 5 CFM PER OCCUPANT & 0.06 CFM PER S.F. OF BLDG. AREA PER SECTION 403.3 OF NCMC IS OCCUPIED.
4. VENTILATION SYSTEM SHALL OPERATE CONTINUOUSLY WHEN BUILDING IS OCCUPIED.
5. VENT FANS SHALL BE DUCTED TO THE EXTERIOR AND TERMINATE AT AN APPROVED VENT CAP.
6. THERMOSTATS MUST BE PROGRAMMABLE
7. EXHAUST FANS SHALL PROVIDE A MINIMUM OF 70 CFM FOR EACH WATER CLOSET & URINAL AND SHALL VENT NO CLOSER THAN 10 FEET FROM MECHANICAL INTAKE.

ACCESSIBILITY NOTES:

1. THE INTERNATIONAL SYMBOL OF ACCESSIBILITY SIGN SHALL BE DISPLAYED AT ALL ACCESSIBLE RESTROOM FACILITIES AND AT ACCESSIBLE BUILDING ENTRANCES UNLESS ALL ENTRANCES ARE ACCESSIBLE. INACCESSIBLE ENTRANCES SHALL HAVE DIRECTIONAL SIGNS INDICATING THE ROUTE TO THE NEAREST ACCESSIBLE ENTRANCE.
2. ACCESSIBLE DRINKING FOUNTAINS SHALL HAVE A SPOUT HEIGHT NO HIGHER THAN 36 INCHES ABOVE THE FLOOR AND EDGE OF BASIN NO HIGHER THAN 34 INCHES ABOVE THE FLOOR FOR INDIVIDUALS IN WHEELCHAIRS. ADDITIONALLY, DRINKING WATER PROVISIONS SHALL BE MADE FOR INDIVIDUALS WHO HAVE DIFFICULTY BENDING.
3. WHERE STORAGE FACILITIES SUCH AS CABINETS, SHELVES, CLOSETS AND DRAWERS ARE PROVIDED AT LEAST ONE TYPE PROVIDED SHALL CONTAIN STORAGE SPACE COMPLYING WITH THE FOLLOWING: DOORS ETC. TO SUCH SPACES SHALL BE ACCESSIBLE (I.E. TOUCH LATCHES, U-SHAPED PULLS); SPACES SHALL BE 15 INCHES MINIMUM AND 48 INCHES MAXIMUM ABOVE THE FLOOR FOR FORWARD REACH OR SIDE REACH; CLOTHES RODS OR COAT HOOKS SHALL BE A MAXIMUM OF 48 INCHES ABOVE THE FLOOR (48 INCHES MAXIMUM WHEN DISTANCE FROM CHAIR TO ROD EXCEEDS 10 INCHES); SHELVES IN KITCHENS OR TOILET ROOMS SHALL BE 40 INCHES MINIMUM AND 48 INCHES MAXIMUM ABOVE IN FLOOR.
4. CONTROLS, DISPENSERS, RECEPTACLES AND OTHER OPERABLE EQUIPMENT SHALL BE NO HIGHER THAN 48 INCHES ABOVE THE FLOOR. RECEPTACLES ON WALLS SHALL BE MOUNTED NO LESS THAN 15 INCHES ABOVE THE FLOOR. EXCEPTION; HEIGHT LIMITATIONS DO NOT APPLY WHERE THE USE OF SPECIAL EQUIPMENT DICTATES OTHERWISE OR WHERE ELECTRICAL RECEPTACLES ARE NOT NORMALLY INTENDED FOR USE BY BUILDING OCCUPANTS.
5. WHERE EMERGENCY WARNING SYSTEMS ARE PROVIDED, THEY SHALL INCLUDE BOTH AUDIBLE AND VISUAL ALARMS. THE VISUAL ALARMS SHALL BE LOCATED THROUGHOUT, INCLUDING RESTROOM, AND PLACED 80 INCHES ABOVE THE FLOOR OR 6 INCHES BELOW CEILING, WHICH-EVER IS LOWER.
6. ALL DOORS SHALL BE OPENABLE BY A SINGLE EFFORT. DOOR CLOSERS SHALL BE ADJUSTED SO THAT FROM AN OPEN POSITION OF 90 DEGREES, THE TIME REQUIRED TO MOVE THE DOOR TO AN OPEN POSITION OF 12 DEGREES SHALL BE 5 SECONDS MINIMUM. THE MAXIMUM FORCE REQUIRED FOR PUSHING OR PULLING OPEN DOORS OTHER THAN FIRE DOORS SHALL NOT EXCEED 5 LBS. FOR ALL SLIDING, FOLDING, AND INTERIOR HINGED DOORS.
7. FLOOR SURFACES SHALL BE STABLE, FIRM, AND SLIP-RESISTANT. CHANGES IN LEVEL BETWEEN 0.25 INCH AND 0.5 INCH SHALL BE BEVELED WITH A SLOPE NO GREATER THAN 1:2. CHANGES IN LEVEL GREATER THAN 0.5 INCH REQUIRE RAMPS. CARPET PILE THICKNESS SHALL BE 0.5 MAX. GRATINGS IN FLOOR SHALL HAVE SPACES NO GREATER THAN 0.5 INCH WIDE IN ONE DIRECTION. DOORWAY THRESHOLDS SHALL NOT EXCEED 0.5 INCH IN HEIGHT.
8. ACCESSIBLE WATER CLOSETS SHALL BE 17 INCHES TO 19 INCHES, MEASURED FROM THE FLOOR TO THE TOP OF THE SEAT. GRAB BARS SHALL BE 36 INCHES LONG MINIMUM WHEN LOCATED BEHIND WATER CLOSET AND 42 INCHES MINIMUM WHEN LOCATED ALONG SIDE OF WATER CLOSET, AND SHALL BE MOUNTED 33 INCHES TO 36 INCHES ABOVE THE FLOOR. IN ADDITION, A VERTICAL GRAB BAR 18 INCHES MINIMUM IN LENGTH SHALL BE MOUNTED ON THE SIDEWALL WITH THE BOTTOM OF THE BAR LOCATED BETWEEN 39 AND 41 INCHES ABOVE THE FLOOR, AND WITH THE CENTER LINE OF THE BAR LOCATED BETWEEN 39 INCHES AND 41 INCHES FROM THE REAR WALL.
9. ACCESSIBLE URINALS SHALL BE STALL-TYPE OR WALL HUNG WITH ELONGATED RIMS AT A MAXIMUM OF 17 INCHES ABOVE THE FLOOR.
10. ACCESSIBLE LAVATORIES AND SINKS SHALL BE MOUNTED WITH THE RIM NO HIGHER THAN 34 INCHES ABOVE THE FLOOR. KNEE CLEARANCE OF AT LEAST 27 INCHES HIGH MUST BE PROVIDED WITH A MINIMUM DEPTH OF 8 INCHES BENEATH THE FIXTURE, AND 9 INCHES HIGH MINIMUM WITH A MINIMUM DEPTH OF 11 INCHES BENEATH THE FIXTURE. THE KNEE SPACE MUST BE AT LEAST 30 INCHES WIDE.
11. HOT WATER AND DRAIN PIPES UNDER ACCESSIBLE LAVATORIES AND SINKS SHALL BE INSULATED OR OTHERWISE CONFIGURED TO PROTECT AGAINST CONTACT. INSULATION OR PROTECTION MATERIALS MAY BE SITE INSTALLED. THERE SHALL BE NO SHARP OR ABRASIVE SURFACES UNDER ACCESSIBLE LAVATORIES AND SINKS.
12. ACCESSIBLE LAVATORIES AND SINKS SHALL HAVE ACCESSIBLE FAUCETS (I.E. LEVER-OPERATED, PUSH TYPE, ELECTRONICALLY CONTROLLED).
13. MIRRORS LOCATED ABOVE LAVATORIES, SINKS OR COUNTERS SHALL BE MOUNTED WITH THE BOTTOM EDGE OF THE REFLECTING SURFACE A MAXIMUM OF 40 INCHES ABOVE THE FLOOR. OTHER MIRRORS IN TOILET ROOMS SHALL BE MOUNTED WITH THE BOTTOM EDGE OF THE REFLECTING SURFACE 35 INCHES MAXIMUM ABOVE THE FLOOR.
14. GRAB BARS HAVING A CIRCULAR CROSS SECTION SHALL HAVE AN OUTSIDE DIAMETER OF 1.25 INCHES MINIMUM AND 2.0 INCHES MAXIMUM. THE SPACE BETWEEN THE GRAB BAR AND THE WALL SHALL BE 1.5 INCHES.
15. WATER CLOSET FLUSH CONTROL SHALL BE INSTALLED A MAXIMUM OF 36 INCHES ABOVE THE FLOOR AND SHALL BE LOCATED ON THE OPEN SIDE OF THE WATER CLOSET.
16. DOORS TO ALL ACCESSIBLE SPACES SHALL HAVE ACCESSIBLE HARDWARE (I.E. LEVER - OPERATED, PUSH TYPE, U-SHAPED) MOUNTED WITH OPERABLE PARTS BETWEEN 34 INCHES MINIMUM AND 48 INCHES MAXIMUM ABOVE THE FLOOR.
17. TOILET STALL DOORS SHALL BE THE SELF-CLOSING TYPE.
18. A TOWEL DISPENSER SHALL BE LOCATED ADJACENT TO ALL ACCESSIBLE LAVATORIES.

**! ATTENTION LOCAL INSPECTIONS DEPARTMENT !
SITE INSTALLED ITEMS:**

THE FOLLOWING ITEMS HAVE NOT BEEN COMPLETED BY THE MANUFACTURER, HAVE NOT BEEN INSPECTED BY THIRD PARTY AND ARE NOT CERTIFIED BY THE STATE MODULAR LABEL. NOTE THAT THIS LIST DOES NOT NECESSARILY LIMIT THE ITEMS OF WORK AND MATERIAL THAT MAY BE REQUIRED FOR A COMPLETE INSTALLATION. ALL SITE RELATED ITEMS ARE SUBJECT TO LOCAL JURISDICTION APPROVAL. CODE COMPLIANCE MUST BE DETERMINED AT THE LOCAL LEVEL.

1. THE COMPLETE FOUNDATION SUPPORT AND TIE DOWN SYSTEM.
2. RAMPS, STAIRS AND GENERAL ACCESS TO THE BUILDING.
3. PORTABLE FIRE EXTINGUISHER(S).
4. ELECTRICAL SERVICE HOOK-UP (INCLUDING FEEDERS) TO THE BUILDING.
5. THE MAIN ELECTRICAL PANEL AND SUB-FEEDERS
6. CONNECTION OF ELECTRICAL CIRCUITS CROSSING OVER MODULE MATELINE(S) - (MULTI-UNITS ONLY).
7. STRUCTURAL AND AESTHETIC INTERCONNECTIONS BETWEEN MODULES (MULTI-UNITS ONLY).
8. FIRE INSPECTION
9. GLAZED OPENING PROTECTION (SEE GENERAL NOTE NO. 8)
10. BUILDING DRAINS, CLEANOUTS, HOOK-UPS TO PLUMBING SYSTEM, & DRINKING FOUNTAIN.

SPECIAL CONDITIONS & REQUIREMENTS:

- ANY SITE ADDED STRUCTURES MUST BE INDEPENDENT OF THE FACTORY BUILDING UNLESS THE ENTIRE BUILDING IS REEVALUATED BY THE SITE ENGINEER.
- TYPICAL FOUNDATION LAYOUT SHOWN IN THIS PACKAGE IS TO AID THE SITE ENGINEER/ARCHITECT FOR LOCATIONS OF REQUIRED SUPPORTS. ACTUAL FOUNDATION MUST BE DESIGNED TO SITE CONDITIONS FOR ALL APPLICABLE LOADS. THIS INCLUDES BUT IS NOT LIMITED TO CONSTRUCTION OF THE FOUNDATION, SEISMIC DESIGN AND ATTACHING THE BUILDING TO THE FOUNDATION, ALONG WITH THE RESISTANCE TO LATERAL, LONGITUDINAL SHEAR, UPLIFT AND DOWNWARD FORCES IN BOTH DIRECTIONS. REFER TO BRACING PAGE FOR APPLICABLE BRACING/SEISMIC LOADS FOR ATTACHING THE BUILDING TO FOUNDATIONS.
- ENGINEER SEAL APPLIES ONLY TO FACTORY MANUFACTURED STRUCTURAL PORTION OF THE BUILDING. SEAL DOES NOT APPLY TO SITE INSTALLED ELEMENTS OR PORTIONS BUILT ON SITE SUCH AS, BUT NOT LIMITED TO: FOUNDATION, BRACING TIE DOWN TO FOUNDATION, EXTERIOR STEPS, OR OTHER SITE WORKS. SITE WORK MUST BE DESIGNED BY OTHERS FOR SITE CONDITIONS, UNDER LOCAL JURISDICTION.

WINDOW & DOOR SPECIFICATIONS:

1. DOUBLE PANE WINDOWS ARE REQUIRED FOR ALL CLIMATE ZONES. SEE THE COMCHECK ENERGY CALCULATIONS FOR THE MAXIMUM ALLOWED U-FACTOR AND SHGC.
2. THE MAXIMUM ALLOWABLE AIR LEAKAGE RATE FOR WINDOWS IS 0.3 CFM PER SQUARE FEET OF WINDOW AREA.
3. THE MAXIMUM ALLOWABLE AIR LEAKAGE RATE FOR EXTERIOR DOORS IS 0.3 CFM PER SQUARE FEET OF DOOR AREA.

PLUMBING NOTES:

1. TOILETS SHALL BE ELONGATED WITH NONABSORBENT OPEN FRONT SEATS.
2. REST ROOM WALLS SHALL BE COVERED WITH NONABSORBENT MATERIAL TO A MINIMUM HEIGHT OF 48 INCHES A.F.F. FLOORS SHALL HAVE A SMOOTH, HARD, NONABSORBENT SURFACE THAT EXTENDS UPWARD ONTO THE WALLS AT LEAST 6 INCHES.
3. THIS BUILDING SHALL BE CONNECTED TO A PUBLIC WATER SUPPLY AND SEWER SYSTEM IF THESE ARE AVAILABLE.
4. ALL PLUMBING FIXTURES SHALL HAVE SEPARATE SHUTOFF VALVES.
5. WATER HEATER SHALL HAVE SAFETY PAN WITH 1 INCH DRAIN TO EXTERIOR. T & P RELIEF VALVE WITH DRAIN TO THROUGH AN AIR GAP 2" TO 6" ABOVE PAN AND A SHUT OFF VALVE WITHIN 3 FEET ON A COLD WATER SUPPLY LINE.
6. DWV SYSTEM SHALL BE EITHER ABS OR PVC - DWV.
7. WATER SUPPLY LINES SHALL BE CPVC, OR COPPER, AND SHALL BE INSTALLED IN ACCORDANCE WITH THE MANUFACTURERS LIMITATIONS AND INSTRUCTIONS.
8. WATER CLOSETS ARE TANK TYPE UNLESS OTHERWISE SPECIFIED. URINALS ARE FLUSH VALVE TYPE.
9. BUILDING DRAIN AND CLEANOUTS ARE DESIGNED AND SITE INSTALLED BY OTHERS, SUBJECT TO LOCAL JURISDICTION APPROVAL.
10. SHOWERS SHALL BE CONTROLLED BY AN APPROVED MIXING VALVE WITH A MAXIMUM WATER OUTLET TEMPERATURE OF 120F (48.8C).
11. THERMAL EXPANSION DEVICE, IF REQUIRED BY WATER HEATER INSTALLED, AND IF NOT SHOWN ON PLUMBING PLAN, IS DESIGNED AND SITE INSTALLED BY OTHERS, SUBJECT TO LOCAL APPROVAL.
12. WATER PIPES INSTALLED IN A WALL EXPOSED TO THE EXTERIOR SHALL BE LOCATED ON THE HEATED SIDE OF THE WALL INSULATION.
13. WATER, SOIL, AND WASTE PIPES IN UNCONDITION SPACES SHALL BE INSULATED AND PROTECTED FROM FREEZING.
14. WHEN RESTROOM FACILITIES AND/OR PLUMBING FIXTURES REQUIRED BY CODE ARE NOT PROVIDED WITHIN THE BLDG. A HANDICAPPED ACCESSIBLE FACILITY MUST BE PROVIDED ON SITE WITHIN THE ALLOWABLE DISTANCE PER CODE. THE REQUIRED FACILITY SHALL BE THE RESPONSIBILITY OF THE BLDG. OWNER AND IS SUBJECT TO THE REVIEW & APPROVAL OF THE LOCAL JURISDICTION HAVING AUTHORITY. THIS NOTE SHALL BE INDICATED ON THE DATA PLATE.
15. CUSTOMER ASSUMES ALL RESPONSIBILITY FOR REQUIRED PLUMBING FIXTURES WHEN NOT SHOWN ON PLAN.
16. TEMPERATURE ACTUATED MIXING VALVES WHICH ARE INSTALLED TO REDUCE WATER TEMPERATURE TO DEFINE LIMITS SHALL COMPLY WITH ASSE 1017
17. TEMPERED WATER SHALL BE SUPPLIED THROUGH A WATER TEMP LIMITING DEVICE THAT CONFORMS TO ASSE 1070 AND SHALL LIMIT THE TEMPERED WATER TO A MAX OF 110F(43C)

STRUCTURAL LOAD LIMITATIONS:

- BUILDING RISK CATEGORY: II
- FLOOR DEAD AND LIVE LOAD:
- A. DEAD LOAD = 12 PSF (AVERAGE).
 - B. UNIFORM LIVE LOAD = 50 PSF
 - C. CONCENTRATED LIVE LOAD = 2000 LB. OVER 30 INCH X 30 INCH AREA LOCATED ANYWHERE ON FLOOR. NOTE: UNIFORM AND CONCENTRATED LIVE LOADS ARE NOT SIMULTANEOUSLY APPLIED.
- ROOF DEAD AND LIVE LOAD:
- A. DEAD LOAD = 13 PSF (AVERAGE).
 - B. LIVE LOAD = 20 PSF.
- ROOF SNOW LOAD:
- A. GROUND SNOW LOAD: Pg = 20 PSF
 - B. FLAT-ROOF SNOW LOAD: Pf = 20 PSF
 - C. SNOW EXPOSURE FACTOR: Ce = 1.0
 - D. SNOW IMPORTANCE FACTOR: Is = 1.0
 - E. SNOW THERMAL FACTOR: Ct = 1.1
- WIND LOAD: ASCE 7-10
- A. WIND SPEED: Vult = 130 MPH
 - B. WIND SPEED: Vosd = 100 MPH
 - C. WIND EXPOSURE CATEGORY: C
 - D. WIND IMPORTANCE FACTOR: Iw = 1.0
 - E. INTERNAL PRESSURE COEFFICIENT: GCpi = 0.18
 - F. PR
- WALL ZONE 5: P = +/-49.2 PSF (Posd = +/-29.5 PSF)
 WALL ZONE 4: P = +/-39.9 PSF (Posd = +/-24.0 PSF)
 ROOF ZONE 3: P = -92.9 PSF (Posd = -55.8 PSF)
 ROOF ZONE 2: P = -61.7 PSF (Posd = -37.0 PSF)
 ROOF ZONE 1: P = -36.8 PSF (Posd = -22.1 PSF)
- G. THIS BUILDING IS NOT DESIGNED FOR PLACEMENT ON THE UPPER HALF OF A HILL OR ESCARPMENT EXCEEDING 15 FEET IN HEIGHT.
- SEISMIC LOAD:
- A. RISK CATEGORY IS II.
 - B. SEISMIC IMPORTANCE FACTOR IS 1.0
 - C. SEISMIC SITE CLASS IS D.
 - D. SPECTRAL RESPONSE COEFFICIENTS: Ss = 0.19 S1 = 0.088 Sds = 0.202 Sd1 = 0.14
 - E. SEISMIC DESIGN CATEGORY IS C.
 - F. SEISMIC FORCE RESISTING SYSTEM IS A15.
 - G. EQUIVALENT LATERAL FORCE ANALYSIS PROCEDURE
 - H. RESPONSE MODIFICATION FACTOR R = 6.5.
 - I. SEISMIC RESPONSE COEFFICIENT Cs = 0.04
 - J. DESIGN BASE SHEAR V = 1609 LBS

NC INSTALLATION INSTRUCTIONS:

! ATTENTION LOCAL INSPECTIONS DEPARTMENT !

INSTALLATION INSTRUCTIONS FOR THIS MODULAR BUILDING ARE INCLUDED BY ATTACHMENT TO THESE PLANS. ANY PLANS SET WHICH DOES NOT CONTAIN AN ATTACHMENT ENTITLED "INSTALLATION INSTRUCTIONS" IS INCOMPLETE. REFER TO THE FOLLOWING SECTIONS OF THE PLAN SET AND INSTALLATION FOR IMPORTANT INFORMATION CONCERNING THE INSTALLATION OF THE MODULAR BUILDING.

1. THE INTERCONNECTION BETWEEN BUILDING MODULES AT THE FLOOR AND ROOF SHALL BE SPECIFIED ON THE CROSS SECTION DRAWING ON THE PLAN SET.
2. BUILDING TIE DOWN AND ANCHORAGE REQUIREMENTS ARE AS INDICATED ON FOUNDATION PLAN.
3. ELECTRICAL INTERCONNECTIONS BETWEEN BUILDING MODULES SHALL BE PER PAGES E1.2, E2.0, E2.1, E2.2, E4.1 OF THE INSTALLATION INSTRUCTIONS (IF APPLICABLE).
4. MECHANICAL INTERCONNECTIONS BETWEEN BUILDING MODULES SHALL BE PER PAGES E1.0, E2.4, E2.5 OF THE INSTALLATION INSTRUCTIONS (IF APPLICABLE).
5. PLUMBING INTERCONNECTIONS BETWEEN BUILDING MODULES SHALL BE PER PAGES E1.1, E1.2, E2.3, E4.1 OF THE INSTALLATION INSTRUCTIONS (IF APPLICABLE).
6. FIRE BLOCKING SHALL BE PROVIDED PER SECTION 718.2 AND 1406.2.3 OF THE N.C. BUILDING CODE (AS APPLICABLE).
7. AIR INFILTRATION AT MODULE MATE LINES SHALL BE LIMITED BY INSTALLING SILL TAPE ALONG THE MATE LINES DURING SET UP AND/OR BY INSTALLING CONTINUOUS SHEATHING ACROSS THE MATE LINE JOINTS AFTER SET UP.

Reviewed for Fire Code Compliance



Leslie Jackson

04/15/2024 7:36:54 AM

BUILDING DESIGN PARAMETERS:

- | | |
|--|-----------|
| 1. USE/OCCUPANCY: | BUSINESS |
| 2. CONSTRUCTION TYPE: | VB |
| 3. SPRINKLER SYSTEM: | NO |
| 4. BUILDING AREA: | 1727 S.F. |
| 5. BUILDING HEIGHT: | ≤ 15 FEET |
| 6. NUMBER OF STORIES: | 1 |
| 7. NUMBER OF MODULES: | 2 |
| 8. OCCUPANT LOAD <u>18</u> BASED ON <u>100</u> SF/PERSON. | |
| 9. EXTERIOR WALL FIRE RATING: | NOT RATED |
| 10. THIS BUILDING MUST BE INSTALLED WITH THE FIRE SEPARATION DISTANCES REQUIRED BY NCBC TABLE 602 AND SECTION 705.3. | |
| 11. ENERGY CODE COMPLIANCE: SEE ATTACHED ENERGY CALCULATIONS. | |
| 12. MANUFACTURERS DATA PLATE, STATE LABELS AND THIRD PARTY LABELS ARE TO BE LOCATED ADJACENT TO ELECTRICAL PANEL. | |

NOTICE TO CONTRACTOR
 All construction must comply with current NC Building Codes and is subject to field inspection and verification.

Reviewed for Code Compliance

04/03/2023

R. JOHNSON
 APPROVED
 02 21 2023

COVER SHEET	SHEET: 1 OF 6
FLOOR PLAN	SHEET: 2 OF 6
ELECTRICAL	SHEET: 3 OF 6
PLUMBING	SHEET: 4 OF 6
ELEVATIONS	SHEET: 5 OF 6
X-SECTION	SHEET: 6 OF 6
FOUNDATION	SHEET: 1 OF 1

CONSULTING ENGINEER: KENNETH EARL DUNMON P.E.
 PO BOX 6853 - AMERICUS, GA 31719 - 229-942-2020



FIRST STRING SPACE, INC.

OUR STRENGTH IS TEAMWORK

892 RAILROAD AVENUE EAST
 PEARSON, GA. 31642
 TEL (912)422-6455
 FAX (912)422-6466

CODE SUMMARY:						
STATE:	BUILDING:	ELECTRICAL:	MECHANICAL:	PLUMBING:	ACCESSIBILITY:	ENERGY:
NORTH CAROLINA	2018 NCBC 2018 NCCFPC	2020 NC ELEC. CODE	2018 NCMC	2018 NCPC	NCBC 2018 CH. 11 AND ICC/ANSI A117.1 - 2009	2018 NC ENERGY CODE

SERIAL NUMBER: FSSI-10912AB	
REFERENCE # FSS-10912AB	STATES: NC
DATE: JANUARY 25, 2023	DESTINATION: BUNNLEVEL, NC
DRAFTSMAN: BRANDON R. DOYLE	SIZE: 23'-4" x 74" (DOUBLE-WIDE)
SCALE: NO SCALE	REVISIONS: N/A
CODES: 2018 NCBC (2015 IBC W/ NC AMENDS)	PLAN NO: FSS 10912AB (NC)
COVER SHEET	SHEET: 1 OF 6

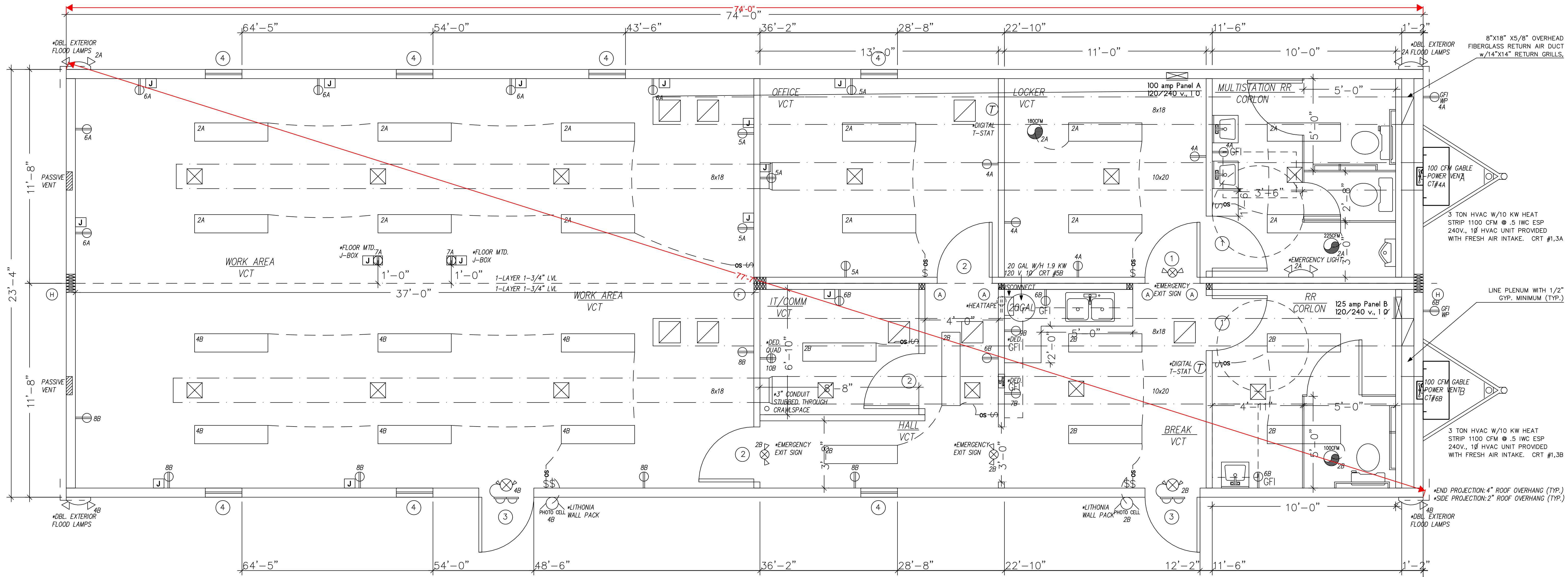

DOOR & WINDOW SCHEDULE:

①	INTERIOR DOOR: 36"x80" SOLID CORE, FLUSH WITH STEEL JAMB REDI-FRAME WITH LEVER, IMPERIAL OAK FINISH WITH BRONZE, PUSH/PULL
②	INTERIOR DOOR: 36"x80" SOLID CORE, FLUSH WITH STEEL JAMB REDI-FRAME WITH LEVER, IMPERIAL OAK FINISH WITH BRONZE, PASSAGE LOCK
③	EXTERIOR DOOR: 36"x80" STEEL FRAME/DOOR WITH 6"x30" VIEW BLOCK, STANDARD TELL LEVER AND TELL CLOSURE (GRADE 2)
④	EXTERIOR WINDOW: CROFT 24"x54" BRONZE METAL FRAME WINDOW, VERTICAL SLIDING, LOW E INSULATED GLASS

COLUMN STRAPPING SCHEDULE:

Ⓐ	(2) 2x4 SYP #2 THIS HALF.	Ⓑ	(2) 2x4 SYP #2 EACH HALF.
Ⓒ	(3) 2x4 SYP #2 THIS HALF.	Ⓓ	(3) 2x4 SYP #2 EACH HALF.
Ⓔ	(4) 2x4 SYP #2 THIS HALF.	Ⓕ	(4) 2x4 SYP #2 EACH HALF.
Ⓖ	(5) 2x4 SYP #2 THIS HALF.	Ⓗ	(3) 2x6 SYP #2 EACH HALF.

NOTES:
 1. ALL COLUMN STUDS SHALL BE GLUE/NAILED TOGETHER.
 PVA GLUE WITH 100% COVERAGE SHALL BE USED.
 2. INSTALL TWO STEEL STRAPS AT EACH STUD OF EACH COLUMN.
 3. COLUMN STUDS SHALL NOT BE NOTCHED OR BORED.

SYMBOLS LEGEND:

	LED LIGHT FIXTURE W/ 2 - 32W TUBES		26W DBL. HEADED EXT. FLOOD/SECURITY LIGHT W/ PHOTOCELL (LED)
	LED PORCH LIGHT 11 WATT		13W CLOSET LIGHT
	EXIT/EMERGENCY LIGHT COMBO W/ BATTERY BACKUP		EXHAUST FAN (CFM VARY)
	120V. DUPLEX RECEPTACLE		ELECTRICAL PANEL BOX 120/208V
	JUNCTION BOX NON-POWERED		POWERED CABLE VENT FAN
	GFI 120V. DUPLEX WEATHER PROOF RECEPT		PASSIVE CABLE VENT FAN
	PROGRAMMABLE THERMOSTAT		SUPPLY AIR GRILLE
	STANDARD LIGHT SWITCH		RETURN AIR GRILLE
	OCCUPANCY SENSOR SWITCH		BARO WALL MOUNT HVAC
	EXIT SIGN W/ DIR. ARROWS		
	EMERGENCY LIGHT		

EMC R. JOHNSON
APPROVED
02 21 2023

CONSULTING ENGINEER: KENNETH EARL DUNMON P.E.
PO BOX 6853 - AMERICUS, GA 31719 - 229-942-2020

FIRST STRING SPACE, INC.
OUR STRENGTH IS TEAMWORK

892 RAILROAD AVENUE EAST
PEARSON, GA. 31642
TEL (912)422-6455
FAX (912)422-6466

SERIAL NUMBER: FSSI-10912AB

REFERENCE # FSS-10912AB	STATES: NC
DATE: JANUARY 25, 2023	DESTINATION: BUNNLEVEL, NC
DRAFTSMAN: BRANDON R. DOYLE	SIZE: 23'-4" x 74" (DOUBLE-WIDE)
SCALE: NO SCALE	REVISIONS: N/A
CODES: 2018 NCBC (2015 IBC W/ NC AMENDS)	PLAN NO: FSS 10912AB (NC)

FLOOR PLAN SHEET: 2 OF 6

(A) ELECTRICAL PANEL SCHEDULE:

CIRCUIT	NOMENCLATURE	BREAKER (AMPS)	WIRE (CU.)
1,3	HVAC (3 Ton)	60A (2P) HACR	6-2 SE w/#10 GRND
2	LIGHTING, FANS	20A	12-2 NM
4,5,6	RECEPTACLES & FANS	20A	12-2 NM
-	WATER HEATER	20A	10-2 NM
-	DED. RECEPES	20A	12-2 NM

ELECTRICAL PANEL SIZING:

DESCRIPTION	KVA
.0035 kW/SF x 863 SF x 1.25	= 3.8
19 RECEPTS @ 180 VA / 1000	= 3.4
3 FANS @ .3 kW x 1.25	= 1.2
0 WATER HEATER @ 6.5kW	= -
0 DED. RECEPT @ 1.9kW x 1.25	= -
1 HVAC	= 10.5
18.9 TOTAL kW	
TOTAL / 240 x 1000 =	79 AMPS
INSTALL 100 AMP PANEL	
120/240 V, 1 PHASE	

(B) ELECTRICAL PANEL SCHEDULE:

CIRCUIT	NOMENCLATURE	BREAKER (AMPS)	WIRE (CU.)
1,3	HVAC (3 Ton)	60A (2P) HACR	6-2 SE w/#10 GRND
2,4	LIGHTING, FANS	20A	12-2 NM
6,8	RECEPTACLES	20A	12-2 NM
5	WATER HEATER	20A	12-2 NM
7,9,10	DED. RECEPES	20A	12-2 NM

ELECTRICAL PANEL SIZING:

DESCRIPTION	KVA
.0035 kW/SF x 863 SF x 1.25	= 3.8
12 RECEPTS @ 180 VA / 1000	= 2.2
2 FANS @ .3 kW x 1.25	= .8
1 WATER HEATER @ 1.9kW x 1.25	= 2.4
2 DED. RECEPT @ 1.9kW x 1.25	= 4.8
1 DED. QUAD RECEPT @ 3.8kW x 1.25	= 4.8
1 HVAC	= 10.5
29.3 TOTAL kW	
TOTAL / 240 x 1000 =	123 AMPS
INSTALL 125 AMP PANEL	
120/240 V, 1 PHASE	





FIRST STRING SPACE, INC.
OUR STRENGTH IS TEAMWORK

892 RAILROAD AVENUE EAST
PEARSON, GA. 31642
TEL (912)422-6455
FAX (912)422-6466

CONSULTING ENGINEER: KENNETH EARL DUNMON P.E.
PO BOX 6853 - AMERICUS, GA 31719 - 229-942-2020



SERIAL NUMBER: FSSI-10912AB	
REFERENCE # FSS-10912AB	STATES: NC
DATE: JANUARY 25, 2023	DESTINATION: BUNNLEVEL, NC
DRAFTSMAN: BRANDON R. DOYLE	SIZE: 23'-4" x 74' (DOUBLE-WIDE)
SCALE: NO SCALE	REVISIONS: N/A
CODES: 2018 NCBC (2015 IBC W/ NC AMENDS)	PLAN NO: FSS 10912AB (NC)
ELECTRICAL	SHEET: 3 OF 6

REAR ELEVATION

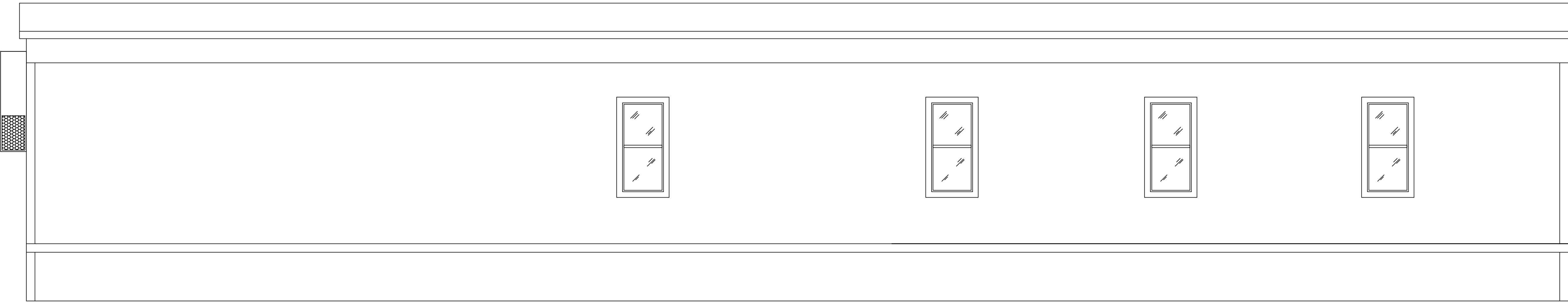

FRONT ELEVATION



ELEVATION NOTES (TYP.):

SEE-CROSS SECTION FOR METHOD OF ROOF VENTILATION

ACCESSIBLE RAMP(S), STAIR(S), AND HANDRAILS ARE SITE INSTALLED, DESIGNED BY OTHERS, AND SUBJECT TO LOCAL JURISDICTION.

FOUNDATION ENCLOSURE (WHEN PROVIDED) MUST HAVE 1 SQUARE FOOT NET VENT AREA PER 1/150TH OF THE FLOOR AREA, AND AN 18" X 24" MINIMUM CRAWL SPACE ACCESS, SITE INSTALLED BY OTHERS SUBJECT TO LOCAL JURISDICTION.

ELEVATIONS SHOWN ON THIS PAGE REPRESENT BASIC COMPONENTS & ARE NOT INTENDED TO BE ALL INCLUSIVE NOR DO THESE ELEVATIONS DETAIL EVERY CODE REQUIRED ASPECT OF THIS BLDG. SITE BUILT STOOPS, STEPS, DECKS PORCHES, HANDRAILS, AND/OR SIMILAR ITEMS MUST BE PROVIDED BY OTHERS ON SITE FOR COMPLIANCE WITH APPLICABLE CODES. COMPLIANCE WITH ALL APPLICABLE CODES PER LOCAL AUTHORITY HAVING JURISDICTION, WHETHER DETAILED IN THIS SET OR NOT, MUST BE MET.

RIGHT ELEVATION

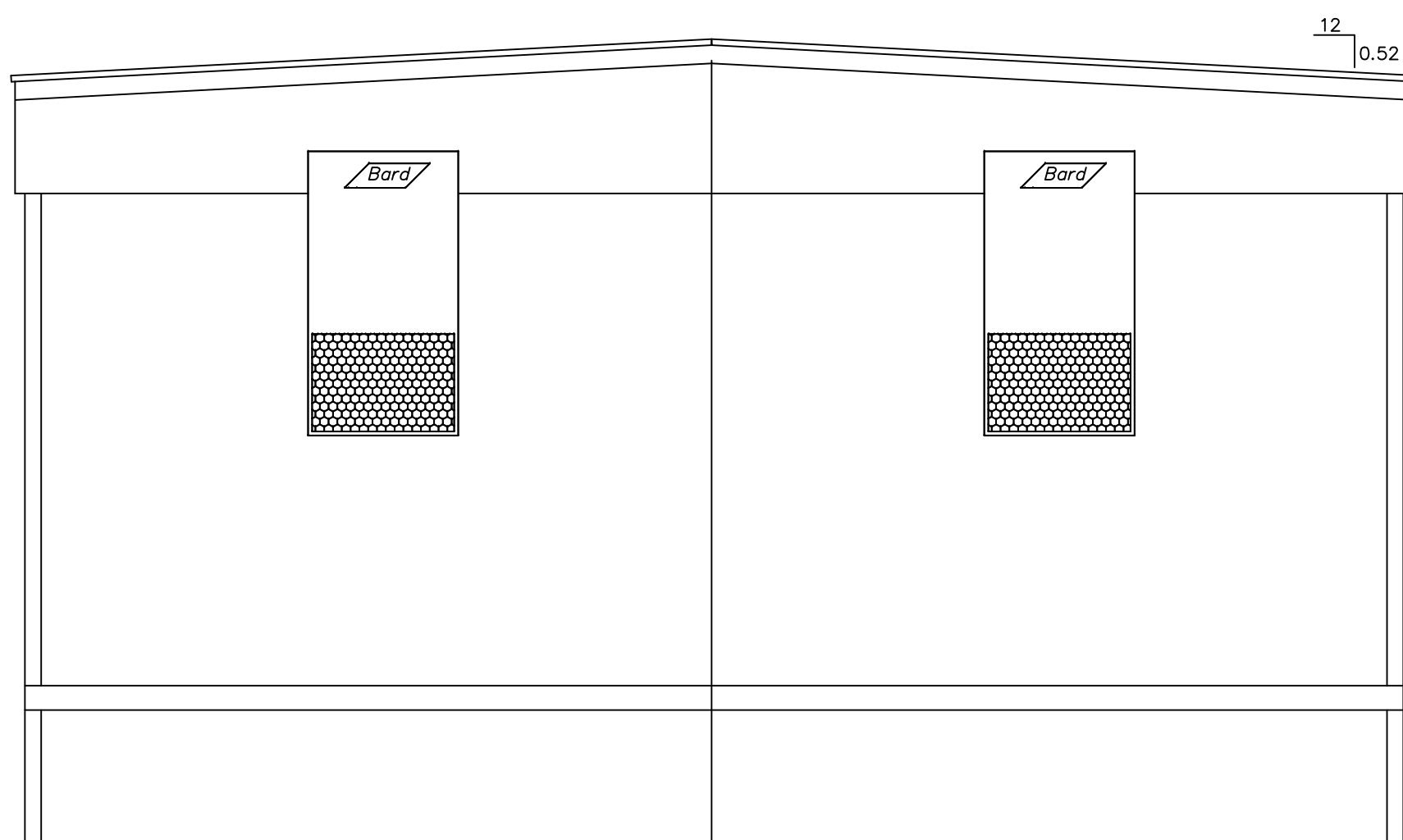

LEFT ELEVATION

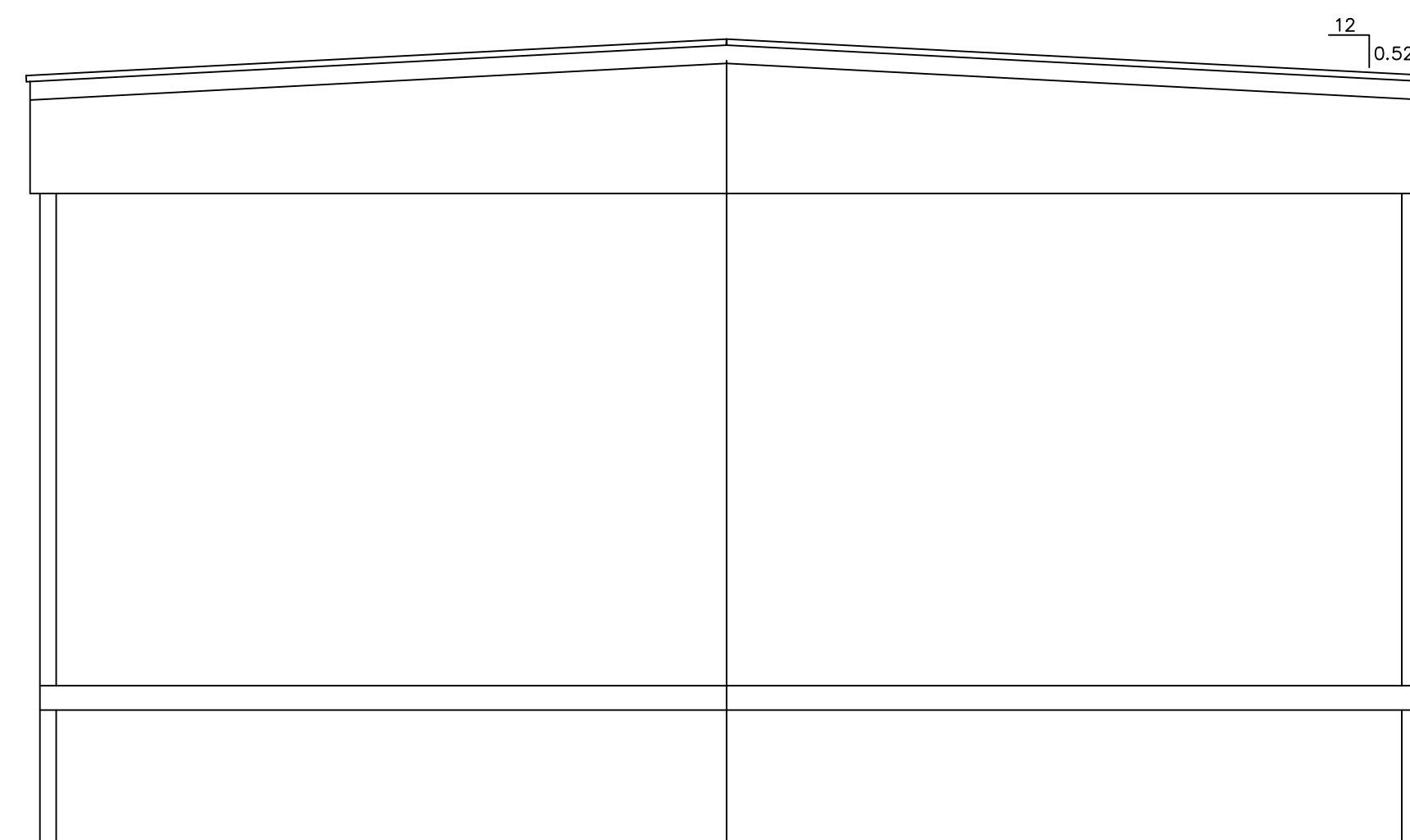

CONSULTING ENGINEER: KENNETH EARL DUNMON P.E.
PO BOX 6853 - AMERICUS, GA 31719 - 229-942-2020





FIRST STRING SPACE, INC.

OUR STRENGTH IS TEAMWORK

892 RAILROAD AVENUE EAST
PEARSON, GA. 31642
TEL (912)422-6455
FAX (912)422-6466

SERIAL NUMBER: FSSI-10912AB	
REFERENCE # FSS-10912AB	STATES: NC
DATE: JANUARY 25, 2023	DESTINATION: BUNNLEVEL, NC
DRAFTSMAN: BRANDON R. DOYLE	SIZE: 23'-4" x 74" (DOUBLE-WIDE)
SCALE: NO SCALE	REVISIONS: N/A
CODES: 2018 NBC (2015 IBC W/ NC AMENDS)	PLAN NO: FSS 10912AB (INC)
ELEVATIONS	SHEET: 5 OF 6

INTERIOR FINISH MATERIAL:

CEILING: 1/2" HIGH STRENGTH GYPSUM BOARD w/ SEA-SPRAY FINISH INSTALLED PER MANUFACTURER'S SPECIFICATIONS

WALL: 5/8" TYPE 'X' GYP. BOARD (VCG) INSTALLED PER MANUFACTURERS SPECIFICATIONS

FLOOR: ARMSTRONG CORLON COMMERCIAL ROLL VINYL INSTALLED IN RESTROOMS AND JANITOR'S CLOSET VINYL COMPOSITE TILE (ARMSTRONG) INSTALLED THROUGHOUT REMAINDER OF FLOORPLAN.

NOTE: INTERIOR WALL & CEILING FINISH SHALL BE CLASS B OR BETTER IN CORRIDORS & CLASS C OR BETTER IN ROOMS AND ENCLOSED SPACES. FLOOR FINISHES SHALL BE CLASS II OR BETTER.

EXTERIOR FINISH MATERIAL:

ROOF: MULE-HIDE 45 MIL (BLACK) EPDM (ESR-1463) FULLY ADHERED TO 7/16" OSB OR 1/2" PLYWOOD WITH MULE-HIDE FR ADHESIVE IN ACCORDANCE WITH INTERTEK REPORT CCRR-1078 (CLASS C ROOF)

WALL: 26 GAUGE HI-RIB STEEL SIDING OVER APPROVED MOISTURE BARRIER OVER 7/16" OSB INSTALLED PER MANUFACTURER'S SPECIFICATIONS

GENERAL CROSS-SECTION NOTES:

- UNLESS OTHERWISE SPECIFIED, ALL STEEL MUST COMPLY w/ASTM A36, YIELD STRENGTH = 36 KSI.
- ALL LAG SCREWS MUST COMPLY WITH ANSI/ASME B18.2.1. Fyb = 60 K.S.I. MIN.
- SEE FOUNDATION PLAN FOR PIER AND TIE-DOWN STRAPPING LOCATIONS, ORIENTATIONS, AND SPECIFICATIONS.
- FOUNDATION PIERS AND FOOTINGS SHOWN ARE FOR REPRESENTATION ONLY. REFER TO FOUNDATION PLAN FOR DESIGN DETAILS.
- RESTROOM VENTILATION IS PROVIDED BY (2) 100CFM FANS/LIGHT COMBOS
- OSB OR PLYWOOD BEARING STRIP IS THE SAME THICKNESS AS THE CEILING MATERIAL. TO BE INSTALLED AS NECESSARY AT BEARING WALLS & COLUMNS.

ROOF SHEATHING DETAIL:

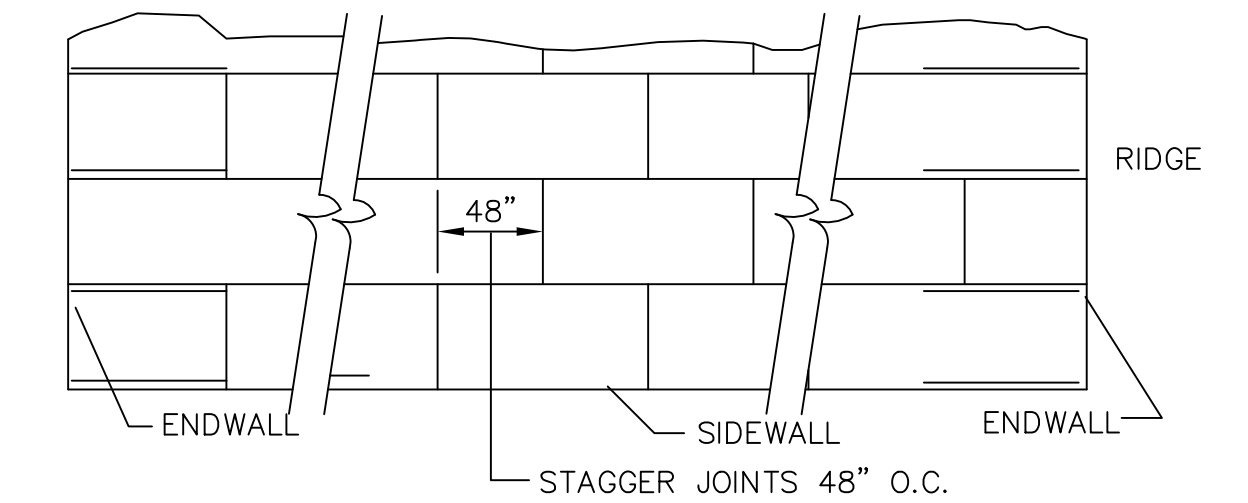

ROOF SHEATHING FASTENED TO TRUSSES W/0.131"Ø x 2 1/2" NAILS AT 6" O.C. ON EDGES & 6" O.C. IN THE FIELD ON ALL ZONES

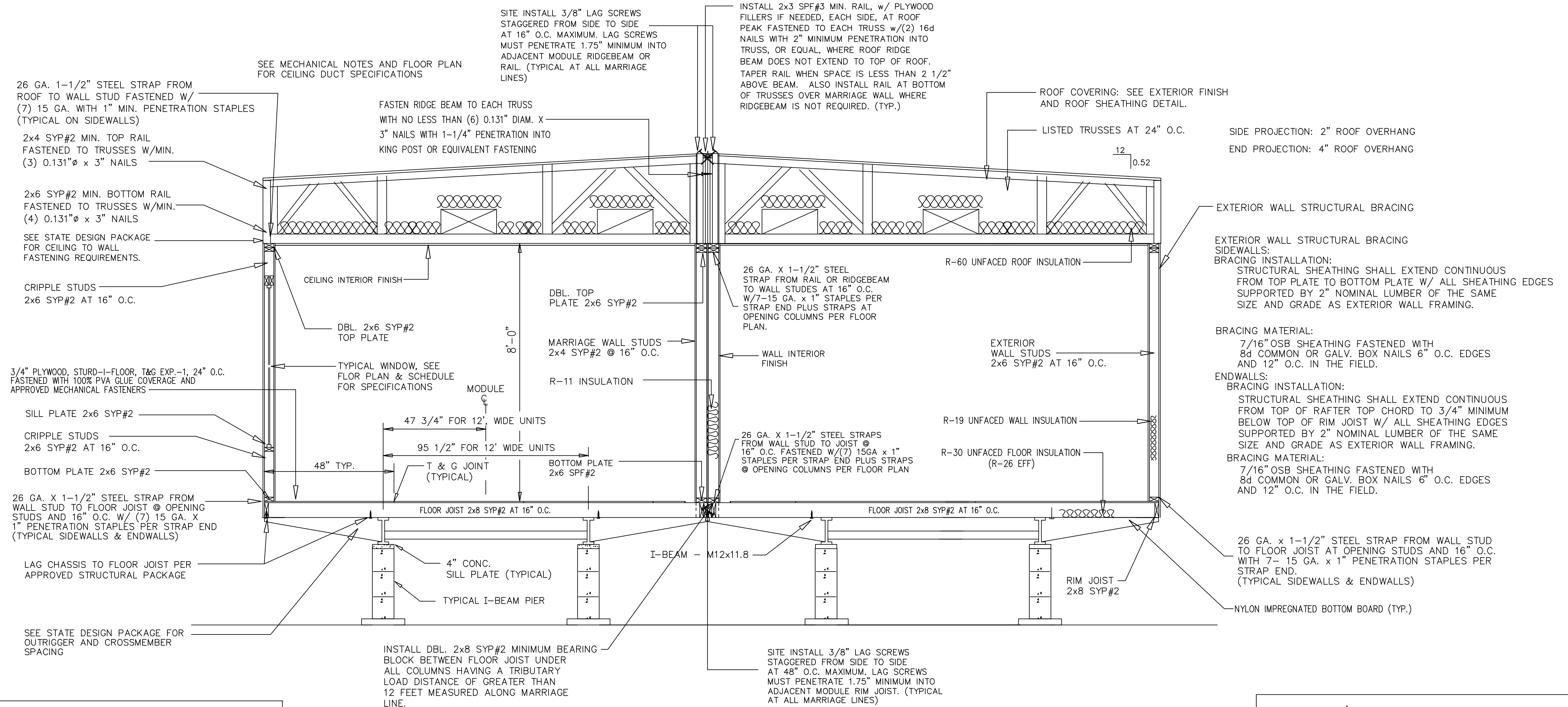

RIDGE BEAM CONSTRUCTION:

(1) LAYER(S), 1-3/4" x 24" MICROLAM, EACH MODULE.

NOTES:

- MICROLAM F = 2750 PSI.
- MICROLAM MUST BE CONTINUOUS OVER CLEARSPAN(S).
- BEAMS SUPPORTED BY ENDWALL COLUMNS MUST EXTEND CONTINUOUS OVER COLUMNS TO EXTERIOR FACE OF ENDWALL.
- FASTEN ROOF SHEATHING INTO TOP EDGE OF MICROLAM TO PROVIDE CONTINUOUS LATERAL SUPPORT OF BEAM
- INSTALL (2x4) x 20" SPF# 3 RIDGE BEAM BEARING STIFFENER OVER SUPPORT COLUMNS WHEN SPECIFIED ON FLOOR PLAN; FASTEN THE FACE OF THE STIFFENER TO THE RIDGE BEAM WITH 100% GLUE COVERAGE AND 6-16 GA. STAPLES WITH 3/4" MINIMUM PENETRATION INTO MICROLAM BEAM.
- WHEN MORE THAN ONE LAYER OF MICROLAM IS INSTALLED ON EITHER SIDE OF THE MATING LINE, LAYERS ON THAT SIDE OF THE MATING LINE MUST BE FASTENED TOGETHER WITH 16 GA. STAPLES x 7/16" MINIMUM CROWN (INSTALLED PARALLEL TO BEAM SPAN) x 3/4" MINIMUM PENETRATION INTO CONNECTING LAYER. STAPLES SHALL BE PLACED AT 6" O.C. MAXIMUM VERTICALLY AND HORIZONTALLY WITH FIRST AND LAST ROW OF STAPLES LOCATED 1" FROM TOP AND BOTTOM EDGE BEAM.

CROSS SECTION

SCALE: N.T.S.

APPROVED TRUSS DESIGN:

TRUSS MANUF # : UNIVERSAL

TRUSS DRAWING. # SF351201

SEE ATTACHED DWG.



CONSULTING ENGINEER: KENNETH EARL DUNMON P.E.
PO BOX 6853 - AMERICUS, GA 31719 - 229-942-2020



FIRST STRING SPACE, INC.
OUR STRENGTH IS TEAMWORK

892 RAILROAD AVENUE EAST
PEARSON, GA. 31642
TEL (912)422-6455
FAX (912)422-6466

SERIAL NUMBER: FSSI-10912AB	
REFERENCE # FSS-10912AB	STATES: NC
DATE: JANUARY 25, 2023	DESTINATION: BUNNLEVEL, NC
DRAFTSMAN: BRANDON R. DOYLE	SIZE: 23'-4" x 74" (DOUBLE-WIDE)
SCALE: NO SCALE	REVISIONS: N/A
CODES: 2018 NBC (2015 IBC W/ NC AMENDS)	PLAN NO: FSS 10912AB (NC)
X-SECTION	
SHEET: 6 OF 6	

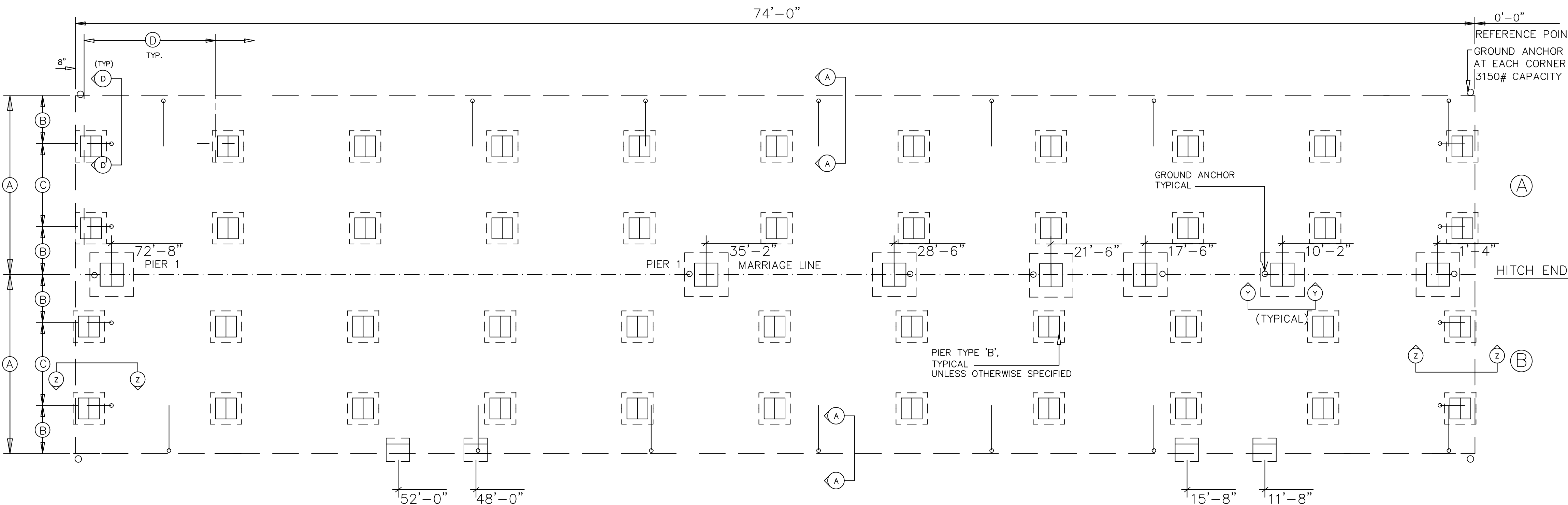
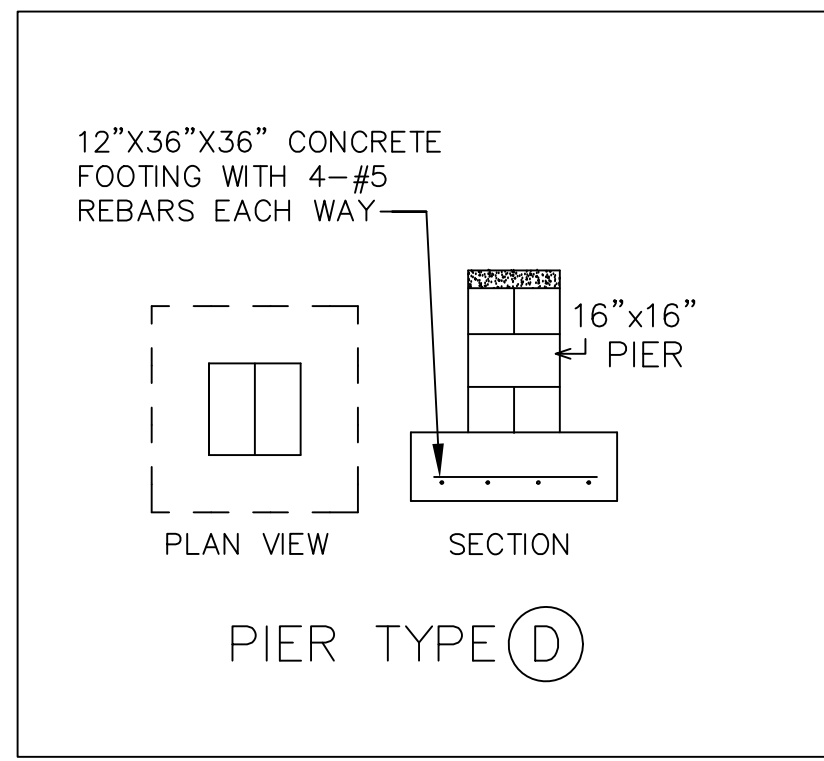
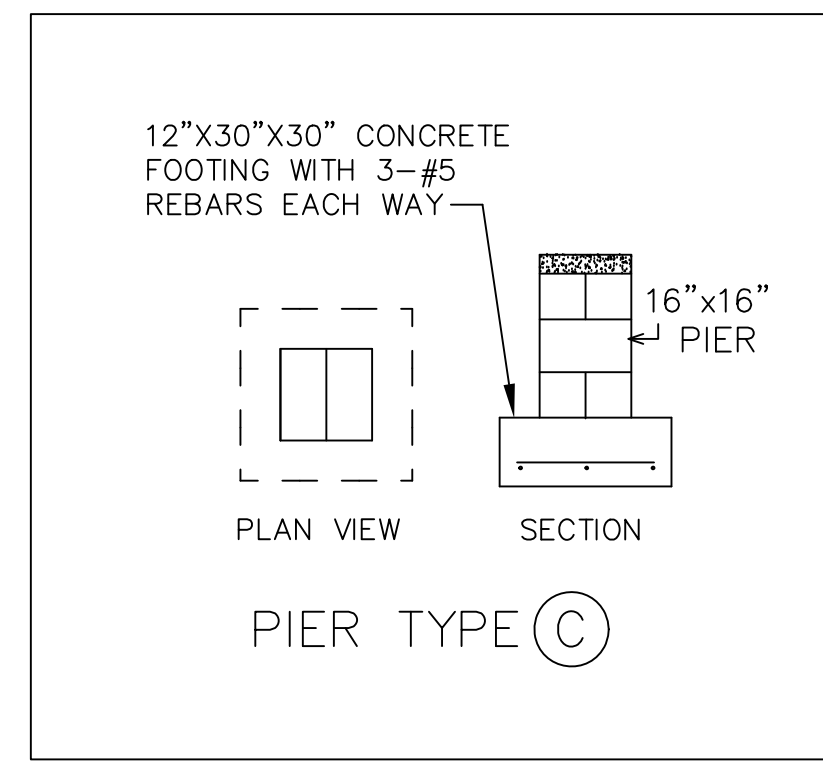
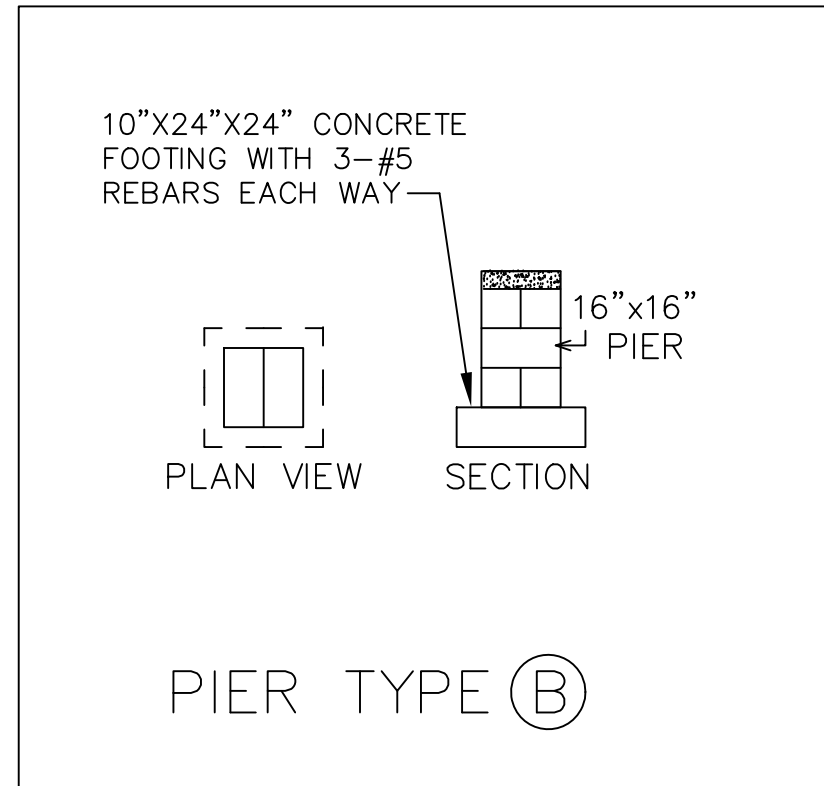
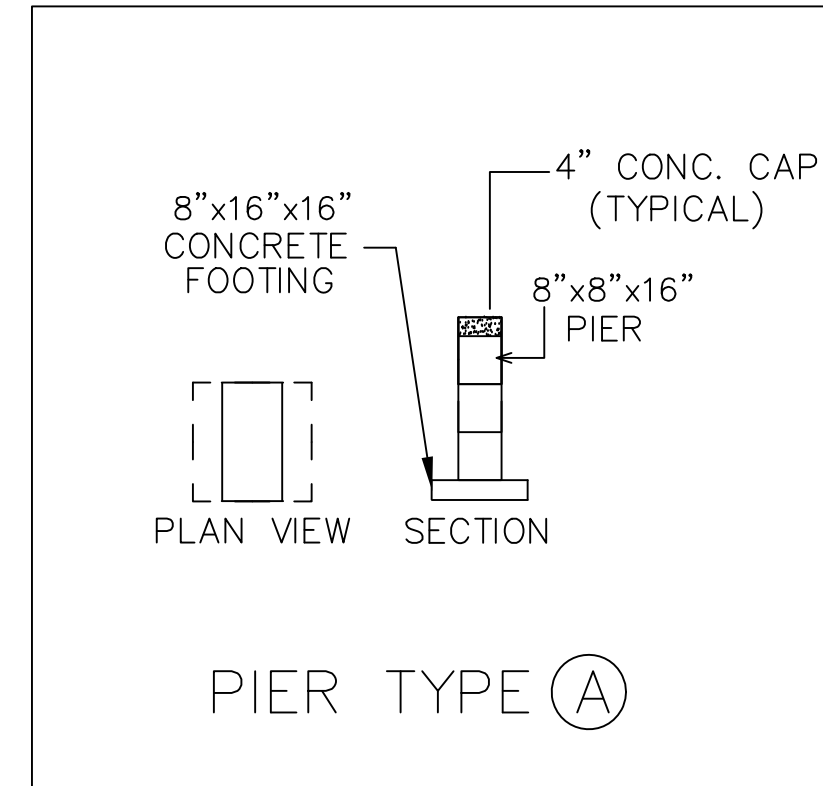
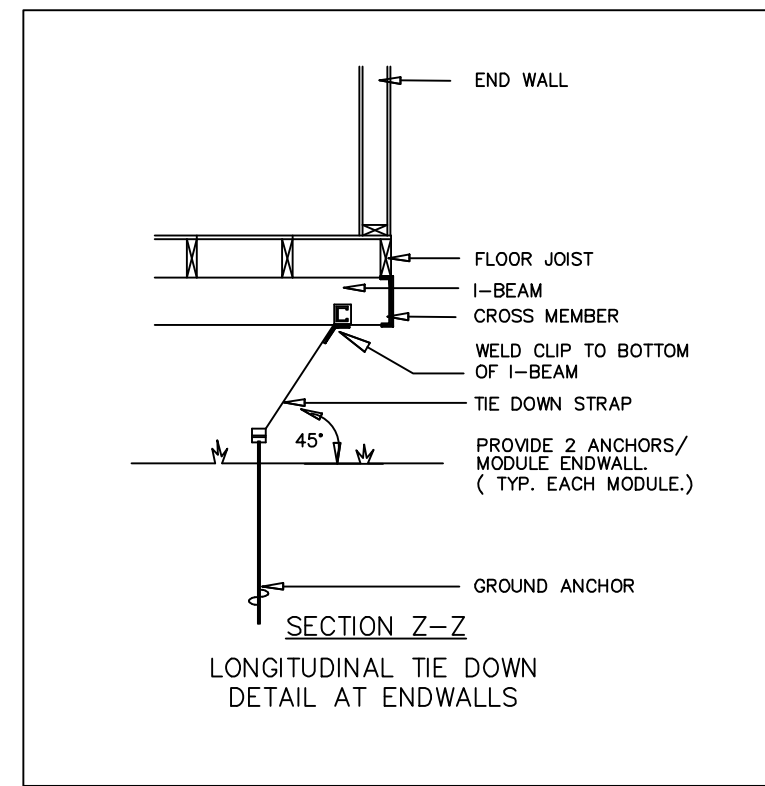
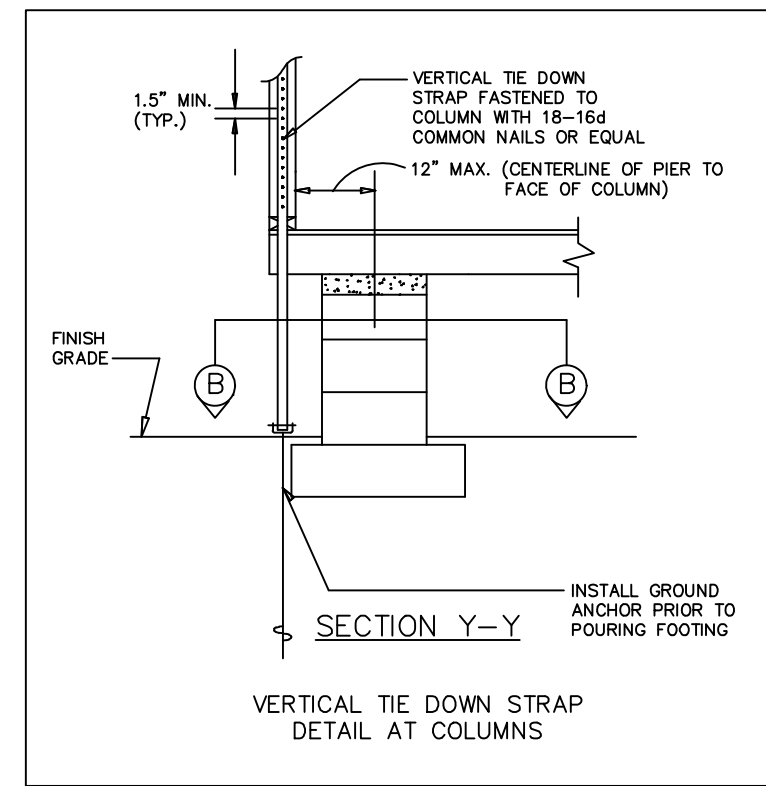
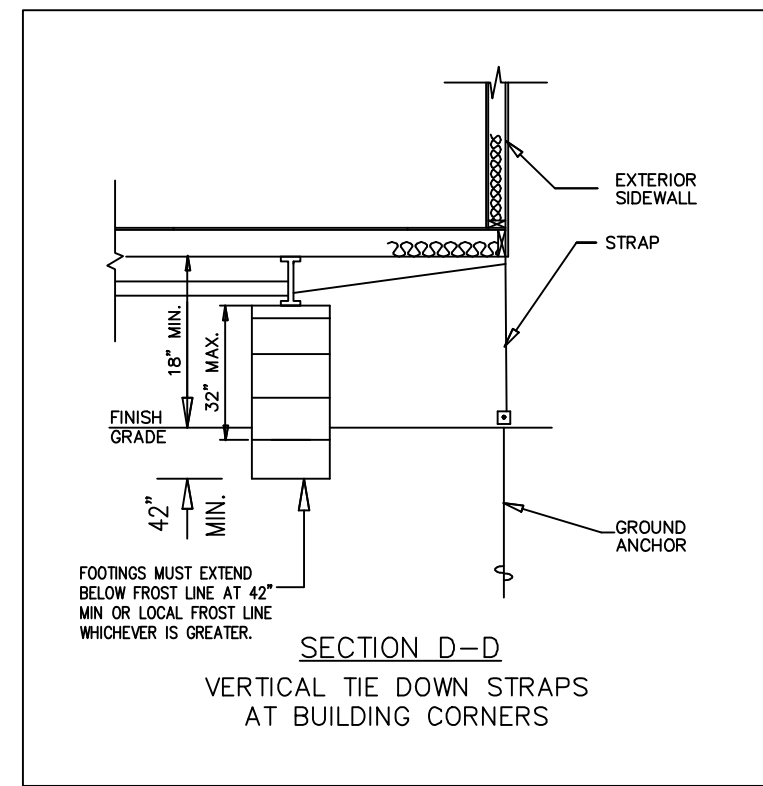
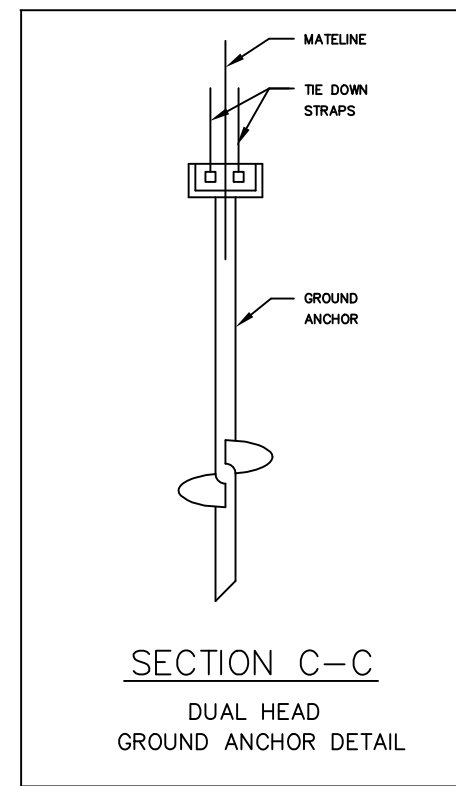
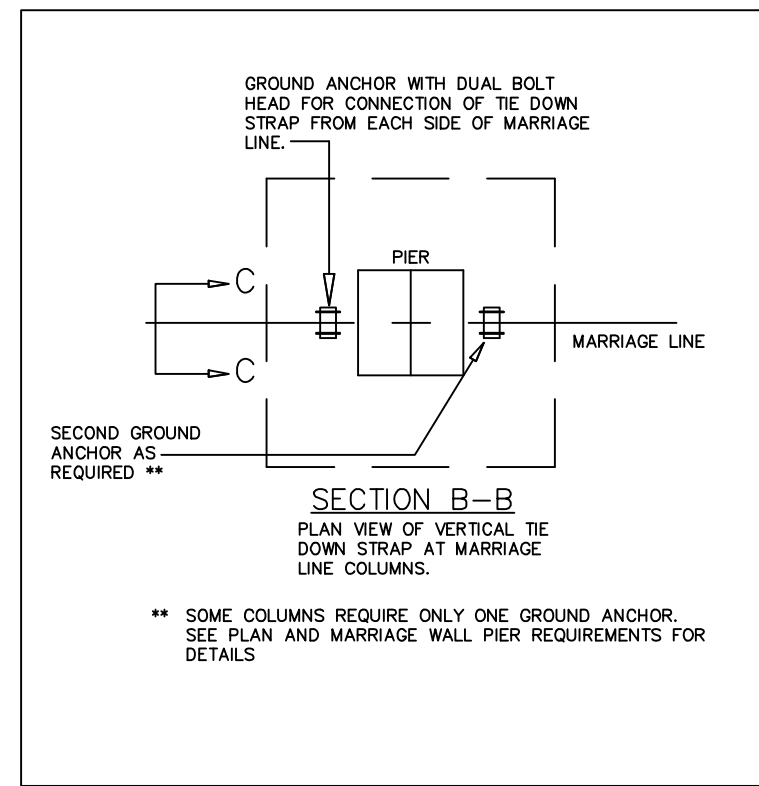
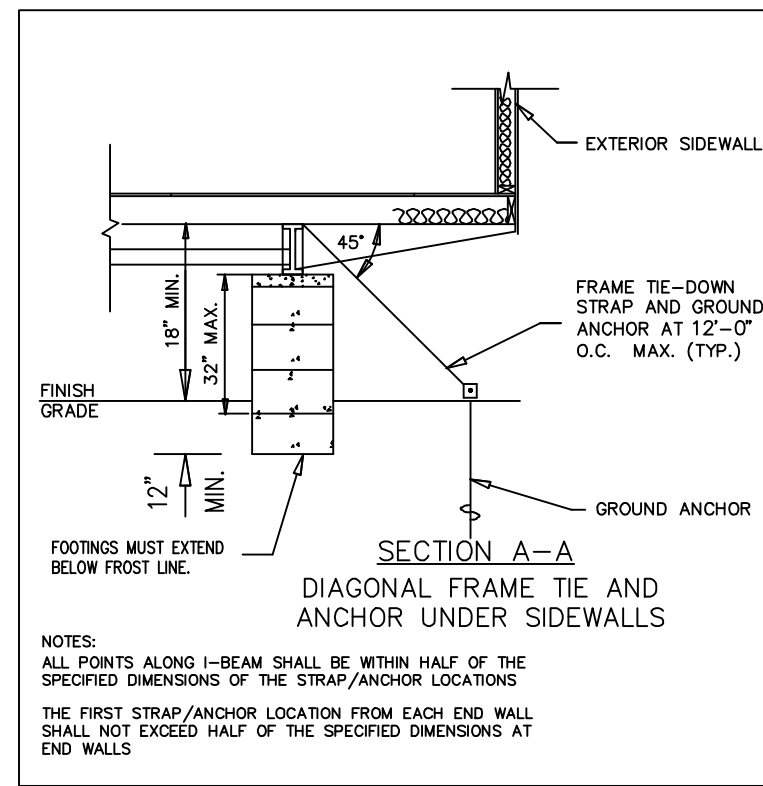

MARRIAGE WALL PIER REQUIREMENTS			
PIER NUMBER	MINIMUM SOIL BEARING CAPACITY	PIER TYPE	NUMBER OF VERTICAL TIE DOWN STRAPS REQ'D (EACH MODULE)
1	2000 PSF	D	1
	3000 PSF	C	1

- FOUNDATION NOTES:**
- ALL FOUNDATION CONSTRUCTION, MATERIALS, AND INSTALLATION SHALL BE IN ACCORDANCE WITH ALL APPLICABLE STATE AND LOCAL CODES.
 - TIE-DOWN STRAPS TO BE 1-1/4" x .035" TYPE-1, FINISH B, GRADE 1 ZINC COATED STEEL STRAPPING CERTIFIED BY A REGISTERED ENGINEER OR ARCHITECT AS CONFORMING WITH ASTM D3953-91. TIE DOWN STRAPS AND CONNECTING HARDWARE SHALL HAVE 3150# MINIMUM WORKING CAPACITY.
 - EACH GROUND ANCHOR SHALL HAVE A WORKING CAPACITY NO LESS THAN THE SUM OF THE REQUIRED WORKING CAPACITIES OF ALL TIE DOWN STRAPS CONNECTED TO THE GROUND ANCHOR, AND SHALL BE INSTALLED IN ACCORDANCE WITH THE MANUFACTURER'S SPECIFICATIONS. DESIGN OF GROUND ANCHOR, INCLUDING SHAFT LENGTH, NUMBER AND DIAMETER OF HELICES, ETC., TO BE AS SPECIFIED BY THE GROUND ANCHOR MANUFACTURER FOR THE ACTUAL SOIL TYPE ENCOUNTERED. IF THE HOLDING OR PULLOUT CAPACITIES OF GROUND ANCHORS ARE BELOW THE ASSUMED DESIGN VALUES, THE ARCHITECT/ENGINEER MUST BE CONSULTED FOR AN ALTERNATE ANCHORAGE DESIGN.
 - THE FIRST TIE-DOWN STRAP FROM ENDWALLS SHALL NOT EXCEED 1/2 THE MAXIMUM SPACING INDICATED.
 - ALL PIERS SHALL BE CONSTRUCTED OF CONCRETE MASONRY UNITS CONFORMING TO ASTM C90. MASONRY UNITS SHALL BE LAID IN TYPE M OR S MORTAR OR COVERED WITH SURFACE BONDING CEMENT INSTALLED IN ACCORDANCE WITH ITS LISTING. PIER FOOTINGS SHALL BE AS DESCRIBED ABOVE.
 - MINIMUM CONCRETE FOOTING COMPRESSIVE STRENGTH 2,500 PSI AT 28 DAYS.
 - ALL REINFORCEMENT BARS SHALL COMPLY WITH ASTM A615, GRADE 60. REINFORCEMENT BARS SHALL BE EQUALLY SPACED AND PLACED WITH 3" CLEARANCE FROM BOTTOM AND SIDES OF THE FOOTING.
 - SEE SHEET 1 OF 5 FOR BUILDING DESIGN LOADS.
 - I-BEAM SUPPORT PIERS MAY BE INSTALLED LATERALLY (90° FROM THE ORIENTATION SHOWN ON THE FOUNDATION PLAN). CENTERLINE OF EACH PIER MUST BE LOCATED DIRECTLY BELOW THE I-BEAM CENTERLINE.
 - SOIL BEARING CAPACITY SHOWN ON THIS PLAN IS ASSUMED. IF THE ACTUAL SOIL BEARING CAPACITY IS LESS THAN 2,000 PSF, THE ARCHITECT/ENGINEER MUST BE CONSULTED FOR REQUIRED ALTERNATE FOUNDATION DESIGN. FOOTINGS SHALL BE PLACED ON NON-EXPANSIVE SOILS ONLY.
 - INSTALL BLOCK PIER ON EACH SIDE OF ALL EXTERIOR DOOR OPENINGS. (MANUFACTURER'S RECOMMENDATION ONLY - OPTIONAL, WHEN NOT SHOWN) SLIGHT ADJUSTMENT MAY BE REQUIRED TO INSURE OPENABILITY AFTER INSTALLATION OF BUILDING IS COMPLETE.
 - THE FOUNDATION DIMENSIONS SHOWN ON THE ABOVE LAYOUT ARE NOMINAL DIMENSIONS OF THE FACTORY BUILT MODULARS AND DO NOT ACCOUNT FOR GAPS BETWEEN MODULES THAT MAY OCCUR DURING INSTALLATION. THE FOUNDATION DESIGNER, FOUNDATION CONTRACTOR AND MODULAR BUILDING INSTALLER MUST CONSULT TO DETERMINE IF ADJUSTMENTS TO PIER LOCATIONS ARE NEEDED TO ACCOUNT FOR TOLERANCES NEEDED DURING INSTALLATION OF THE BUILDING MODULES
 - THE AREA UNDER FOOTINGS AND FOUNDATIONS SHALL HAVE ALL VEGETATION, STUMPS, ROOTS, AND FOREIGN MATERIALS REMOVED PRIOR TO THEIR CONSTRUCTION.

FOUNDATION ENCLOSURE (WHEN PROVIDED) MUST HAVE 1 SQUARE FOOT NET VENT AREA PER 1/150TH OF THE FLOOR AREA, AND AN 18" X 24" MINIMUM CRAWL SPACE ACCESS, SITE INSTALLED BY OTHERS SUBJECT TO LOCAL JURISDICTION.

NOTE: THE NUMBER OF PIERS SHOWN ON THIS FOUNDATION PLAN IS NO INDICATION OF THE AMOUNT OF PIERS REQUIRED AND NEEDED FOR THIS BUILDING. SEE MAXIMUM PIER SPACING CHARTS ABOVE FOR THE CORRECT NUMBER OF PIERS REQUIRED FOR EACH SOIL BEARING CAPACITY. ALSO, THE NUMBER STRAPS (SPACING) WILL BE DETERMINED IN SECTION A-A. THE NUMBER OF ALL COMPONENTS OF THIS FOUNDATION PLAN CAN BE FOUND IN THE CHARTS AND DETAILS ABOVE.

NOTE: THIS FOUNDATION PLAN IS PROVIDED FOR REFERENCE AS A TYPICAL STANDARD. ACTUAL FOUNDATION CONDITIONS MUST BE EVALUATED FOR APPLICABILITY IF THIS PLAN IS TO BE USED. ALTERNATE FOUNDATION PLANS MAY BE DESIGNED BY OTHERS IN ACCORDANCE WITH THE REQUIREMENTS OF THE JURISDICTION HAVING AUTHORITY.

● TYPICAL FOUNDATION LAYOUT SHOWN IS TO AID THE SITE ENGINEER/ARCHITECT FOR ENGINEER/ARCHITECT FOR LOCATIONS OF REQUIRED SUPPORTS. ACTUAL FOUNDATION MUST BE DESIGNED TO SITE CONDITIONS FOR ALL APPLICABLE LOADS. THIS INCLUDES BUT IS NOT LIMITED TO CONSTRUCTION OF THE FOUNDATION, SEISMIC DESIGN AND ATTACHING THE BUILDING TO THE FOUNDATION, ALONG WITH THE RESISTANCE TO LATERAL, LONGITUDINAL SHEAR, UPLIFT AND DOWNWARD FORCES IN BOTH DIRECTIONS.

NOTICE TO FOUNDATION CONTRACTOR:
ALL DIMENSIONS, DETAILS AND NOTES ON THIS FOUNDATION PLAN MUST BE REVIEWED AND VERIFIED BY THE FOUNDATION CONTRACTOR PRIOR TO COMMENCEMENT OF CONSTRUCTION OF THE FOUNDATION. ANY APPARENT CONFLICTS, ERRORS OR OMISSIONS MUST BE BROUGHT TO THE ATTENTION OF THE DESIGN PROFESSIONAL FOR RESOLUTION PRIOR TO PROCEEDING WITH CONSTRUCTION. THE CONTRACTOR MUST OBTAIN APPROVAL OF THE FOUNDATION PLAN FROM THE LOCAL BUILDING DEPARTMENT PRIOR TO COMMENCING CONSTRUCTION AND MUST COMPLY WITH ALL STATE AND LOCAL CODE, APPROVAL AND INSPECTION REQUIREMENTS. EMC IS NOT THE DESIGNER OF THE BUILDING OR THE FOUNDATION AND IS NOT RESPONSIBLE OR LIABLE FOR ANY CONFLICTS, ERRORS, OMISSIONS OR FAILURES TO COMPLY WITH STATE OR LOCAL CODES.

FOUNDATION DIMENSIONS				
MODULE WIDTH	B PIER TO MODULE EDGE	C STEEL BEAM SPACING	D MAXIMUM PIER SPACING	MINIMUM SOIL BEARING CAPACITY
11'-8"	22 1/4"	95 1/2"	9'-0"	2000 PSF
			9'-0"	3000 PSF



CONSULTING ENGINEER: KENNETH EARL DUNMON P.E.
PO BOX 6853 - AMERICUS, GA 31719 - 229-942-2020



FIRST STRING SPACE, INC.

OUR STRENGTH IS TEAMWORK

892 RAILROAD AVENUE EAST
PEARSON, GA. 31642
TEL (912)422-6455
FAX (912)422-6466

SERIAL NUMBER: FSSI-10912AB	
REFERENCE # FSS-10912AB	STATES: NC
DATE: JANUARY 25, 2023	DESTINATION: BUNNLEVEL, NC
DRAFTSMAN: BRANDON R. DOYLE	SIZE: 23'-4" x 74" (DOUBLE-WIDE)
SCALE: NO SCALE	REVISIONS: N/A
CODES: 2018 NCBC (2015 IBC W/ NC AMENDS)	PLAN NO: FSS 10912AB (INC)
FOUNDATION	SHEET: 1 OF 1

Envelope Compliance Statement

Compliance Statement: The proposed envelope design represented in this document is consistent with the building plans, specifications, and other calculations submitted with this permit application. The proposed envelope systems have been designed to meet the 90.1 (2016) Standard requirements in COMcheck Version 4.1.5.1 and to comply with any applicable mandatory requirements listed in the Inspection Checklist.

Name - Title

Signature

Date



**R. JOHNSON
APPROVED
02 21 2023**



Interior Lighting Compliance Certificate

Project Information

Energy Code: 90.1 (2016) Standard
 Project Title: FSS-10912
 Project Type: New Construction



R. JOHNSON
APPROVED
02 21 2023

Construction Site: _____ Owner/Agent: _____ Designer/Contractor:
 First String Space
 892 Railroad Avenue East
 Pearson, GA 31642

Allowed Interior Lighting Power

A Area Category	B Floor Area (ft ²)	C Allowed Watts / ft ²	D Allowed Watts (B X C)
1-Office	1727	0.79	1364
Total Allowed Watts =			1364

Proposed Interior Lighting Power

A Fixture ID : Description / Lamp / Wattage Per Lamp / Ballast	B Lamps/ Fixture	C # of Fixtures	D Fixture Watt.	E (C X D)
1-Office LED 1: LED Linear 33W:	1	25	33	825
Total Proposed Watts =				825

Interior Lighting PASSES: Design 40% better than code

Interior Lighting Compliance Statement

Compliance Statement: The proposed interior lighting design represented in this document is consistent with the building plans, specifications, and other calculations submitted with this permit application. The proposed interior lighting systems have been designed to meet the 90.1 (2016) Standard requirements in COMcheck Version 4.1.5.1 and to comply with any applicable mandatory requirements listed in the Inspection Checklist.

Name - Title _____

Signature _____



Exterior Lighting Compliance Statement

Compliance Statement: The proposed exterior lighting design represented in this document is consistent with the building plans, specifications, and other calculations submitted with this permit application. The proposed exterior lighting systems have been designed to meet the 90.1 (2016) Standard requirements in COM with any applicable mandatory requirements listed in the Inspection Checklist.

Name - Title

Signature

Date



**R. JOHNSON
APPROVED
02 21 2023**



Mechanical Compliance Certificate

Project Information

Energy Code: 90.1 (2016) Standard
 Project Title: FSS-10912
 Location: Dunn, North Carolina
 Climate Zone: 3a
 Project Type: New Construction



R. JOHNSON
APPROVED
02 21 2023

Construction Site: _____ Owner/Agent: _____ Designer/Contractor:
 First String Space
 892 Railroad Avenue East
 Pearson, GA 31642

Mechanical Systems List

Quantity System Type & Description

- 2 HVAC System 1 (Single Zone):
 Heating: 1 each - Other, Electric, Capacity = 34 kBtu/h
 No minimum efficiency requirement applies
 Cooling: 1 each - Single Package Vertical AC Unit, Capacity = 36 kBtu/h, Air-Cooled Condenser
 Proposed Efficiency = 11.00 EER, Required Efficiency: 10.00 EER
 Fan System: FAN SYSTEM 1 -- Compliance (Motor nameplate HP method) : Passes

 Fans:
 FAN 1 Supply, Constant Volume, 1100 CFM, 0.3 motor nameplate hp, 0.0 fan efficiency grade
- 1 Water Heater 1:
 Electric Storage Water Heater, Capacity: 20 gallons
 No minimum efficiency requirement applies

Mechanical Compliance Statement

Compliance Statement: The proposed mechanical design represented in this document is consistent with the building plans, specifications, and other calculations submitted with this permit application. The proposed mechanical systems have been designed to meet the 90.1 (2016) Standard requirements in COMcheck Version 4.1.5.1 and to comply with any applicable mandatory requirements listed in the Inspection Checklist.

Name - Title _____

Signature _____

Date _____





Inspection Checklist

Energy Code: 90.1 (2016) Standard

Requirements: 0.0% were addressed directly in the COMcheck software

Text in the "Comments/Assumptions" column is provided by the user in the COMcheck Requirements screen. For each requirement, the user certifies that a code requirement will be met and how that is documented, or that an exception is being claimed. Where compliance is itemized in a separate table, a reference to that table is provided.

Section # & Req.ID	Plan Review	Complies?	Comments/Assumptions
4.2.2, 5.4.3.1.1, 5.7 [PR1] ¹	Plans and/or specifications provide all information with which compliance can be determined for the building envelope and document where exceptions to the standard are claimed.	<input type="checkbox"/> Complies <input type="checkbox"/> Does Not <input type="checkbox"/> Not Observable <input type="checkbox"/> Not Applicable	
4.2.2, 6.4.4.2.1, 6.7.2 [PR2] ¹	Plans, specifications, and/or calculations provide all information with which compliance can be determined for the mechanical systems and equipment and document where exceptions to the standard are claimed. Load calculations per acceptable engineering standards and handbooks.	<input type="checkbox"/> Complies <input type="checkbox"/> Does Not <input type="checkbox"/> Not Observable <input type="checkbox"/> Not Applicable	
4.2.2, 7.7.1, 10.4.2 [PR3] ¹	Plans, specifications, and/or calculations provide all information with which compliance can be determined for the service water heating systems and equipment and document where exceptions to the standard are claimed. Hot water system sized per manufacturer's sizing guide.	<input type="checkbox"/> Complies <input type="checkbox"/> Does Not <input type="checkbox"/> Not Observable <input type="checkbox"/> Not Applicable	
4.2.2, 8.4.1.1, 8.4.1.2, 8.7 [PR6] ²	Plans, specifications, and/or calculations provide all information with which compliance can be determined for the electrical systems and equipment and document where exceptions are claimed. Feeder connectors sized in accordance with approved plans and branch circuits sized for maximum drop of 3%.	<input type="checkbox"/> Complies <input type="checkbox"/> Does Not <input type="checkbox"/> Not Observable <input type="checkbox"/> Not Applicable	
4.2.2, 9.4.3, 9.7 [PR4] ¹	Plans, specifications, and/or calculations provide all information with which compliance can be determined for the interior lighting and electrical systems and equipment and document where exceptions to the standard are claimed. Information provided should include interior lighting power calculations, wattage of bulbs and ballasts, transformers and control devices.	<input type="checkbox"/> Complies <input type="checkbox"/> Does Not <input type="checkbox"/> Not Observable <input type="checkbox"/> Not Applicable	

1	High Impact (Tier 1)	2	Medium Impact (Tier 2)	3	Low Impact (Tier 3)
---	----------------------	---	------------------------	---	---------------------

Section # & Req.ID	Plan Review	Complies?	Comments/Assumptions
9.7 [PR8] ¹	Plans, specifications, and/or calculations provide all information with which compliance can be determined for the exterior lighting and electrical systems and equipment and document where exceptions to the standard are claimed. Information provided should include exterior lighting power calculations, wattage of bulbs and ballasts, transformers and control devices.	<input type="checkbox"/> Complies <input type="checkbox"/> Does Not <input type="checkbox"/> Not Observable <input type="checkbox"/> Not Applicable	
6.7.2.4 [PR5] ¹	Detailed instructions for HVAC systems commissioning included on the plans or specifications for projects >=50,000 ft ² .	<input type="checkbox"/> Complies <input type="checkbox"/> Does Not <input type="checkbox"/> Not Observable <input type="checkbox"/> Not Applicable	

Additional Comments/Assumptions:

1 High Impact (Tier 1)	2 Medium Impact (Tier 2)	3 Low Impact (Tier 3)
------------------------	--------------------------	-----------------------

Section # & Req.ID	Footing / Foundation Inspection	Plans Verified Value	Field Verified Value	Complies?	Comments/Assumptions
4.2.4 [FO1] ²	Installed below-grade wall insulation type and R-value consistent with insulation specifications reported in plans and COMcheck reports.	R-_____	R-_____	<input type="checkbox"/> Complies <input type="checkbox"/> Does Not <input type="checkbox"/> Not Observable <input type="checkbox"/> Not Applicable	See the Envelope Assemblies table for values.
4.2.4 [FO3] ²	Installed slab-on-grade insulation type and R-value consistent with insulation specifications reported in plans and COMcheck reports.	R-_____ <input type="checkbox"/> Unheated <input type="checkbox"/> Heated	R-_____ <input type="checkbox"/> Unheated <input type="checkbox"/> Heated	<input type="checkbox"/> Complies <input type="checkbox"/> Does Not <input type="checkbox"/> Not Observable <input type="checkbox"/> Not Applicable	See the Envelope Assemblies table for values.
5.5.3.5 [FO5] ²	Slab edge insulation depth/length.	_____ ft	_____ ft	<input type="checkbox"/> Complies <input type="checkbox"/> Does Not <input type="checkbox"/> Not Observable <input type="checkbox"/> Not Applicable	See the Envelope Assemblies table for values.
5.8.1.7 [FO6] ¹	Exterior insulation protected against damage, sunlight, moisture, wind, landscaping and equipment maintenance activities.			<input type="checkbox"/> Complies <input type="checkbox"/> Does Not <input type="checkbox"/> Not Observable <input type="checkbox"/> Not Applicable	
5.8.1.7.3 [FO7] ¹	Insulation in contact with the ground has <=0.3% water absorption rate per ASTM C272.			<input type="checkbox"/> Complies <input type="checkbox"/> Does Not <input type="checkbox"/> Not Observable <input type="checkbox"/> Not Applicable	
6.4.3.7 [FO9] ³	Freeze protection and snow/ice melting system sensors for future connection to controls.			<input type="checkbox"/> Complies <input type="checkbox"/> Does Not <input type="checkbox"/> Not Observable <input type="checkbox"/> Not Applicable	
6.4.4.1.5 [FO11] ³	Bottom surface of floor structures incorporating radiant heating insulated to >=R-3.5.	R-_____	R-_____	<input type="checkbox"/> Complies <input type="checkbox"/> Does Not <input type="checkbox"/> Not Observable <input type="checkbox"/> Not Applicable	See the Envelope Assemblies table for values.

Additional Comments/Assumptions:

1	High Impact (Tier 1)	2	Medium Impact (Tier 2)	3	Low Impact (Tier 3)
---	----------------------	---	------------------------	---	---------------------

Section # & Req.ID	Framing / Rough-In Inspection	Plans Verified Value	Field Verified Value	Complies?	Comments/Assumptions
5.4.3.2 [FR1] ³	Factory-built and site-assembled fenestration and doors are labeled or certified as meeting air leakage requirements.			<input type="checkbox"/> Complies <input type="checkbox"/> Does Not <input type="checkbox"/> Not Observable <input type="checkbox"/> Not Applicable	
5.5.4.3a [FR8] ¹	Vertical fenestration U-Factor.	U-____	U-____	<input type="checkbox"/> Complies <input type="checkbox"/> Does Not <input type="checkbox"/> Not Observable <input type="checkbox"/> Not Applicable	See the Envelope Assemblies table for values.
5.5.4.3b [FR9] ¹	Skylight fenestration U-Factor.	U-____	U-____	<input type="checkbox"/> Complies <input type="checkbox"/> Does Not <input type="checkbox"/> Not Observable <input type="checkbox"/> Not Applicable	See the Envelope Assemblies table for values.
5.5.4.4.1 [FR10] ¹	Vertical fenestration SHGC value.	SHGC:____	SHGC:____	<input type="checkbox"/> Complies <input type="checkbox"/> Does Not <input type="checkbox"/> Not Observable <input type="checkbox"/> Not Applicable	See the Envelope Assemblies table for values.
5.5.4.4.2 [FR11] ¹	Skylight SHGC value.	SHGC:____	SHGC:____	<input type="checkbox"/> Complies <input type="checkbox"/> Does Not <input type="checkbox"/> Not Observable <input type="checkbox"/> Not Applicable	See the Envelope Assemblies table for values.
5.8.2.1, 5.8.2.3, 5.8.2.4, 5.8.2.5 [FR12] ²	Fenestration products rated (U-factor, SHGC, and VT) in accordance with NFRC or energy code defaults are used.			<input type="checkbox"/> Complies <input type="checkbox"/> Does Not <input type="checkbox"/> Not Observable <input type="checkbox"/> Not Applicable	
5.8.2.2 [FR13] ¹	Fenestration and door products are labeled, or a signed and dated certificate listing the U-factor, SHGC, VT, and air leakage rate has been provided by the manufacturer.			<input type="checkbox"/> Complies <input type="checkbox"/> Does Not <input type="checkbox"/> Not Observable <input type="checkbox"/> Not Applicable	
5.5.3.6 [FR14] ²	U-factor of opaque doors associated with the building thermal envelope meets requirements.	U-____ <input type="checkbox"/> Swinging <input type="checkbox"/> Nonswinging	U-____ <input type="checkbox"/> Swinging <input type="checkbox"/> Nonswinging	<input type="checkbox"/> Complies <input type="checkbox"/> Does Not <input type="checkbox"/> Not Observable <input type="checkbox"/> Not Applicable	See the Envelope Assemblies table for values.
5.4.3.1 [FR15] ¹	Continuous air barrier is wrapped, sealed, caulked, gasketed, and/or taped in an approved manner, except in semiheated spaces in climate zones 1-6.			<input type="checkbox"/> Complies <input type="checkbox"/> Does Not <input type="checkbox"/> Not Observable <input type="checkbox"/> Not Applicable	

Additional Comments/Assumptions:

1	High Impact (Tier 1)	2	Medium Impact (Tier 2)	3	Low Impact (Tier 3)
---	----------------------	---	------------------------	---	---------------------

Section # & Req.ID	Plumbing Rough-In Inspection	Complies?	Comments/Assumptions
7.4.4.1 [PL2] ³	Temperature controls installed on service water heating systems (<=120°F to maximum temperature for intended use).	<input type="checkbox"/> Complies <input type="checkbox"/> Does Not <input type="checkbox"/> Not Observable <input type="checkbox"/> Not Applicable	
7.4.6 [PL4] ³	Heat traps installed on non-circulating storage water tanks.	<input type="checkbox"/> Complies <input type="checkbox"/> Does Not <input type="checkbox"/> Not Observable <input type="checkbox"/> Not Applicable	

Additional Comments/Assumptions:

1 High Impact (Tier 1)	2 Medium Impact (Tier 2)	3 Low Impact (Tier 3)
------------------------	--------------------------	-----------------------

Section # & Req.ID	Mechanical Rough-In Inspection	Plans Verified Value	Field Verified Value	Complies?	Comments/Assumptions
6.4.1.4, 6.4.1.5 [ME1] ²	HVAC equipment efficiency verified. Non-NAECA HVAC equipment labeled as meeting 90.1.	Efficiency: _____	Efficiency: _____	<input type="checkbox"/> Complies <input type="checkbox"/> Does Not <input type="checkbox"/> Not Observable <input type="checkbox"/> Not Applicable	See the Mechanical Systems list for values.
6.4.3.4.1 [ME3] ³	Stair and elevator shaft vents have motorized dampers that automatically close.			<input type="checkbox"/> Complies <input type="checkbox"/> Does Not <input type="checkbox"/> Not Observable <input type="checkbox"/> Not Applicable	
6.4.3.4.5 [ME39] ³	Enclosed parking garage ventilation has automatic contaminant detection and capacity to stage or modulate fans to 50% or less of design capacity.			<input type="checkbox"/> Complies <input type="checkbox"/> Does Not <input type="checkbox"/> Not Observable <input type="checkbox"/> Not Applicable	
6.4.3.4.4 [ME5] ³	Ventilation fans >0.75 hp have automatic controls to shut off fan when not required.			<input type="checkbox"/> Complies <input type="checkbox"/> Does Not <input type="checkbox"/> Not Observable <input type="checkbox"/> Not Applicable	
6.4.3.8 [ME6] ¹	Demand control ventilation provided for spaces >500 ft ² and >25 people/1000 ft ² occupant density and served by systems with air side economizer, auto modulating outside air damper control, or design airflow >3,000 cfm.			<input type="checkbox"/> Complies <input type="checkbox"/> Does Not <input type="checkbox"/> Not Observable <input type="checkbox"/> Not Applicable	
6.5.3.2.1 [ME40] ²	DX cooling systems >= 75 kBtu/h (>= 65 kBtu/h effective 1/2016) and chilled-water and evaporative cooling fan motor hp >= ¼ designed to vary supply fan airflow as a function of load and comply with operational requirements.			<input type="checkbox"/> Complies <input type="checkbox"/> Does Not <input type="checkbox"/> Not Observable <input type="checkbox"/> Not Applicable	See the Mechanical Systems list for values.
6.4.4.1.1 [ME7] ³	Insulation exposed to weather protected from damage. Insulation outside of the conditioned space and associated with cooling systems is vapor retardant.			<input type="checkbox"/> Complies <input type="checkbox"/> Does Not <input type="checkbox"/> Not Observable <input type="checkbox"/> Not Applicable	
6.4.4.1.2 [ME8] ²	HVAC ducts and plenums insulated per Table 6.8.2. Where ducts or plenums are installed in or under a slab, verification may need to occur during Foundation Inspection.	R- _____	R- _____	<input type="checkbox"/> Complies <input type="checkbox"/> Does Not <input type="checkbox"/> Not Observable <input type="checkbox"/> Not Applicable	
6.4.4.1.3 [ME9] ²	HVAC piping insulation thickness. Where piping is installed in or under a slab, verification may need to occur during Foundation Inspection.	_____ in.	_____ in.	<input type="checkbox"/> Complies <input type="checkbox"/> Does Not <input type="checkbox"/> Not Observable <input type="checkbox"/> Not Applicable	
6.4.4.1.4 [ME41] ³	Thermally ineffective panel surfaces of sensible heating panels have insulation >= R-3.5.			<input type="checkbox"/> Complies <input type="checkbox"/> Does Not <input type="checkbox"/> Not Observable <input type="checkbox"/> Not Applicable	
6.4.4.2.1 [ME10] ²	Ducts and plenums having pressure class ratings are Seal Class A construction.			<input type="checkbox"/> Complies <input type="checkbox"/> Does Not <input type="checkbox"/> Not Observable <input type="checkbox"/> Not Applicable	

1 High Impact (Tier 1) 2 Medium Impact (Tier 2) 3 Low Impact (Tier 3)

Section # & Req.ID	Mechanical Rough-In Inspection	Plans Verified Value	Field Verified Value	Complies?	Comments/Assumptions
6.8.1-15, 6.8.1-16 [ME110] ²	Electrically operated DX-DOAS units meet requirements per Tables 6.8.1-15 or 6.8.1-16.			<input type="checkbox"/> Complies <input type="checkbox"/> Does Not <input type="checkbox"/> Not Observable <input type="checkbox"/> Not Applicable	
6.4.4.2.2 [ME11] ³	Ductwork operating >3 in. water column requires air leakage testing.			<input type="checkbox"/> Complies <input type="checkbox"/> Does Not <input type="checkbox"/> Not Observable <input type="checkbox"/> Not Applicable	
6.5.2.3 [ME19] ³	Dehumidification controls provided to prevent reheating, recooling, mixing of hot and cold airstreams or concurrent heating and cooling of the same airstream.			<input type="checkbox"/> Complies <input type="checkbox"/> Does Not <input type="checkbox"/> Not Observable <input type="checkbox"/> Not Applicable	
6.5.2.4.1 [ME68] ³	Humidifiers with airstream mounted preheating jackets have preheat auto-shutoff value set to activate when humidification is not required.			<input type="checkbox"/> Complies <input type="checkbox"/> Does Not <input type="checkbox"/> Not Observable <input type="checkbox"/> Not Applicable	
6.5.2.4.2 [ME69] ³	Humidification system dispersion tube hot surfaces in the airstreams of ducts or air-handling units insulated \geq R-0.5.			<input type="checkbox"/> Complies <input type="checkbox"/> Does Not <input type="checkbox"/> Not Observable <input type="checkbox"/> Not Applicable	
6.5.2.5 [ME70] ³	Preheat coils controlled to stop heat output whenever mechanical cooling, including economizer operation, is active.			<input type="checkbox"/> Complies <input type="checkbox"/> Does Not <input type="checkbox"/> Not Observable <input type="checkbox"/> Not Applicable	
6.5.2.6 [ME106] ³	Units that provide ventilation air to multiple zones and operate in conjunction with zone heating and cooling systems are prevented from using heating or heat recovery to warm supply air above 60°F when representative building loads or outdoor air temperature indicate that most zones demand cooling.			<input type="checkbox"/> Complies <input type="checkbox"/> Does Not <input type="checkbox"/> Not Observable <input type="checkbox"/> Not Applicable	
6.5.3.6 [ME72] ²	Motors for fans \geq 1/12 hp and < 1 hp are electronically-commutated motors or have a minimum motor efficiency of 70%. These motors are also speed adjustable for either balancing or remote control.			<input type="checkbox"/> Complies <input type="checkbox"/> Does Not <input type="checkbox"/> Not Observable <input type="checkbox"/> Not Applicable	
6.5.3.4 [ME108] ²	Parallel-flow fan-powered VAV air terminals have automatic controls to a) turn off the terminal fan except when space heating is required or if required for ventilation; b) turn on the terminal fan as the first stage of heating before the heating coil is activated; and c) during heating for warmup or setback temperature control, either operate the terminal fan and heating coil without primary air or reverse the terminal damper logic and provide heating from the central air handler through primary air.			<input type="checkbox"/> Complies <input type="checkbox"/> Does Not <input type="checkbox"/> Not Observable <input type="checkbox"/> Not Applicable	

1 High Impact (Tier 1) 2 Medium Impact (Tier 2) 3 Low Impact (Tier 3)

Section # & Req.ID	Mechanical Rough-In Inspection	Plans Verified Value	Field Verified Value	Complies?	Comments/Assumptions
6.5.3.7 [ME109] ²	Required minimum outdoor air rate is the larger of minimum outdoor air rate or minimum exhaust air rate required by Standard 62.1, Standard 170, or applicable codes or accreditation standards. Outdoor air ventilation systems shall comply with one of the following: a) design minimum system outdoor air provided < 135% of the required minimum outdoor air rate, b) dampers, ductwork, and controls allow the system to supply <= the required minimum outdoor air rate with a single set-point adjustment., or c) system includes exhaust air energy recovery complying with Section 6.5.6.1.			<input type="checkbox"/> Complies <input type="checkbox"/> Does Not <input type="checkbox"/> Not Observable <input type="checkbox"/> Not Applicable	
6.5.3.3 [ME42] ³	Multiple zone VAV systems with DDC of individual zone boxes have static pressure setpoint reset controls.			<input type="checkbox"/> Complies <input type="checkbox"/> Does Not <input type="checkbox"/> Not Observable <input type="checkbox"/> Not Applicable	See the Mechanical Systems list for values.
6.5.4.2 [ME25] ³	HVAC pumping systems with >= 3 control valves designed for variable fluid flow (see section details).			<input type="checkbox"/> Complies <input type="checkbox"/> Does Not <input type="checkbox"/> Not Observable <input type="checkbox"/> Not Applicable	
6.5.6.1 [ME56] ¹	Exhaust air energy recovery on systems meeting Tables 6.5.6.1-1, and 6.5.6.1-2.			<input type="checkbox"/> Complies <input type="checkbox"/> Does Not <input type="checkbox"/> Not Observable <input type="checkbox"/> Not Applicable	
6.5.7.1 [ME100] ²	Conditioned supply air to space with mechanical exhaust <= the greater of criteria of supply flow, required ventilation rate, exhaust flow minu the available transfer air (see section details).			<input type="checkbox"/> Complies <input type="checkbox"/> Does Not <input type="checkbox"/> Not Observable <input type="checkbox"/> Not Applicable	
6.5.7.2.1 [ME32] ²	Kitchen hoods >5,000 cfm have make up air >=50% of exhaust air volume.			<input type="checkbox"/> Complies <input type="checkbox"/> Does Not <input type="checkbox"/> Not Observable <input type="checkbox"/> Not Applicable	
6.5.7.2.4 [ME49] ³	Approved field test used to evaluate design air flow rates and demonstrate proper capture and containment of kitchen exhaust systems.			<input type="checkbox"/> Complies <input type="checkbox"/> Does Not <input type="checkbox"/> Not Observable <input type="checkbox"/> Not Applicable	
6.5.8.1 [ME34] ²	Unenclosed spaces that are heated use only radiant heat.			<input type="checkbox"/> Complies <input type="checkbox"/> Does Not <input type="checkbox"/> Not Observable <input type="checkbox"/> Not Applicable	
7.4.2 [ME36] ²	Service water heating equipment meets efficiency requirements.			<input type="checkbox"/> Complies <input type="checkbox"/> Does Not <input type="checkbox"/> Not Observable <input type="checkbox"/> Not Applicable	

1 High Impact (Tier 1) 2 Medium Impact (Tier 2) 3 Low Impact (Tier 3)

Section # & Req.ID	Mechanical Rough-In Inspection	Plans Verified Value	Field Verified Value	Complies?	Comments/Assumptions
6.4.3.9 [ME63] ²	Heating for vestibules and air curtains with integral heating include automatic controls that shut off the heating system when outdoor air temperatures > 45F. Vestibule heating and cooling systems controlled by a thermostat in the vestibule with heating setpoint <= 60F and cooling setpoint >= 80F.			<input type="checkbox"/> Complies <input type="checkbox"/> Does Not <input type="checkbox"/> Not Observable <input type="checkbox"/> Not Applicable	
6.5.10 [ME73] ³	Doors separating conditioned space from the outdoors have controls that disable/reset heating and cooling system when open.			<input type="checkbox"/> Complies <input type="checkbox"/> Does Not <input type="checkbox"/> Not Observable <input type="checkbox"/> Not Applicable	

Additional Comments/Assumptions:

1	High Impact (Tier 1)	2	Medium Impact (Tier 2)	3	Low Impact (Tier 3)
---	----------------------	---	------------------------	---	---------------------

Section # & Req.ID	Rough-In Electrical Inspection	Complies?	Comments/Assumptions
8.4.2 [EL10] ²	At least 50% of all 125 volt 15- and 20-Amp receptacles are controlled by an automatic control device.	<input type="checkbox"/> Complies <input type="checkbox"/> Does Not <input type="checkbox"/> Not Observable <input type="checkbox"/> Not Applicable	
8.4.3 [EL11] ²	New buildings have electrical energy use measurement devices installed. Where tenant spaces exist, each tenant is monitored separately. In buildings with a digital control system the energy use is transmitted to to control system and displayed graphically.	<input type="checkbox"/> Complies <input type="checkbox"/> Does Not <input type="checkbox"/> Not Observable <input type="checkbox"/> Not Applicable	
9.4.1.1 [EL1] ²	Automatic control requirements prescribed in Table 9.6.1, for the appropriate space type, are installed. Mandatory lighting controls (labeled as 'REQ') and optional choice controls (labeled as 'ADD1' and 'ADD2') are implemented.	<input type="checkbox"/> Complies <input type="checkbox"/> Does Not <input type="checkbox"/> Not Observable <input type="checkbox"/> Not Applicable	
9.4.1.1 [EL2] ²	Independent lighting controls installed per approved lighting plans and all manual controls readily accessible and visible to occupants.	<input type="checkbox"/> Complies <input type="checkbox"/> Does Not <input type="checkbox"/> Not Observable <input type="checkbox"/> Not Applicable	
9.4.1.1f [EL13] ¹	Daylight areas under skylights and roof monitors that have more than 150 W combined input power for general lighting are controlled by photocontrols.	<input type="checkbox"/> Complies <input type="checkbox"/> Does Not <input type="checkbox"/> Not Observable <input type="checkbox"/> Not Applicable	
9.4.1.4 [EL3] ²	Automatic lighting controls for exterior lighting installed.	<input type="checkbox"/> Complies <input type="checkbox"/> Does Not <input type="checkbox"/> Not Observable <input type="checkbox"/> Not Applicable	
9.4.1.3 [EL4] ¹	Separate lighting control devices for specific uses installed per approved lighting plans.	<input type="checkbox"/> Complies <input type="checkbox"/> Does Not <input type="checkbox"/> Not Observable <input type="checkbox"/> Not Applicable	
9.6.2 [EL8] ¹	Additional interior lighting power allowed for special functions per the approved lighting plans and is automatically controlled and separated from general lighting.	<input type="checkbox"/> Complies <input type="checkbox"/> Does Not <input type="checkbox"/> Not Observable <input type="checkbox"/> Not Applicable	
10.4.1 [EL9] ²	Electric motors meet requirements where applicable.	<input type="checkbox"/> Complies <input type="checkbox"/> Does Not <input type="checkbox"/> Not Observable <input type="checkbox"/> Not Applicable	

Additional Comments/Assumptions:

1	High Impact (Tier 1)	2	Medium Impact (Tier 2)	3	Low Impact (Tier 3)
---	----------------------	---	------------------------	---	---------------------

Section # & Req.ID	Insulation Inspection	Plans Verified Value	Field Verified Value	Complies?	Comments/Assumptions
4.2.4 [IN2] ¹	Installed roof insulation type and R-value consistent with insulation specifications reported in plans and COMcheck reports. For some ceiling systems, verification may need to occur during Framing Inspection.	R-_____ <input type="checkbox"/> Above deck <input type="checkbox"/> Metal <input type="checkbox"/> Attic	R-_____ <input type="checkbox"/> Above deck <input type="checkbox"/> Metal <input type="checkbox"/> Attic	<input type="checkbox"/> Complies <input type="checkbox"/> Does Not <input type="checkbox"/> Not Observable <input type="checkbox"/> Not Applicable	See the Envelope Assemblies table for values.
5.8.1.2, 5.8.1.3 [IN3] ¹	Roof insulation installed per manufacturer's instructions. Blown or poured loose-fill insulation is installed only where the ceiling slope is <= 3:12.			<input type="checkbox"/> Complies <input type="checkbox"/> Does Not <input type="checkbox"/> Not Observable <input type="checkbox"/> Not Applicable	
4.2.4 [IN6] ¹	Installed above-grade wall insulation type and R-value consistent with insulation specifications reported in plans and COMcheck reports.	R-_____ <input type="checkbox"/> Mass <input type="checkbox"/> Metal <input type="checkbox"/> Steel <input type="checkbox"/> Wood	R-_____ <input type="checkbox"/> Mass <input type="checkbox"/> Metal <input type="checkbox"/> Steel <input type="checkbox"/> Wood	<input type="checkbox"/> Complies <input type="checkbox"/> Does Not <input type="checkbox"/> Not Observable <input type="checkbox"/> Not Applicable	See the Envelope Assemblies table for values.
5.8.1.2 [IN7] ¹	Above-grade wall insulation installed per manufacturer's instructions.			<input type="checkbox"/> Complies <input type="checkbox"/> Does Not <input type="checkbox"/> Not Observable <input type="checkbox"/> Not Applicable	
4.2.4 [IN8] ²	Installed floor insulation type and R-value consistent with insulation specifications reported in plans and COMcheck reports.	R-_____ <input type="checkbox"/> Mass <input type="checkbox"/> Steel <input type="checkbox"/> Wood	R-_____ <input type="checkbox"/> Mass <input type="checkbox"/> Steel <input type="checkbox"/> Wood	<input type="checkbox"/> Complies <input type="checkbox"/> Does Not <input type="checkbox"/> Not Observable <input type="checkbox"/> Not Applicable	See the Envelope Assemblies table for values.
5.8.1.2 [IN9] ²	Floor insulation installed per manufacturer's instructions.			<input type="checkbox"/> Complies <input type="checkbox"/> Does Not <input type="checkbox"/> Not Observable <input type="checkbox"/> Not Applicable	
5.8.1.1 [IN10] ²	Building envelope insulation is labeled with R-value or insulation certificate has been provided listing R-value and other relevant data.			<input type="checkbox"/> Complies <input type="checkbox"/> Does Not <input type="checkbox"/> Not Observable <input type="checkbox"/> Not Applicable	
5.8.1.9 [IN18] ²	Building envelope insulation extends over the full area of the component at the proposed rated R or U value.			<input type="checkbox"/> Complies <input type="checkbox"/> Does Not <input type="checkbox"/> Not Observable <input type="checkbox"/> Not Applicable	
5.8.1.4 [IN11] ²	Eaves are baffled to deflect air to above the insulation.			<input type="checkbox"/> Complies <input type="checkbox"/> Does Not <input type="checkbox"/> Not Observable <input type="checkbox"/> Not Applicable	
5.8.1.5 [IN12] ²	Insulation is installed in substantial contact with the inside surface separating conditioned space from unconditional space.			<input type="checkbox"/> Complies <input type="checkbox"/> Does Not <input type="checkbox"/> Not Observable <input type="checkbox"/> Not Applicable	
5.8.1.6 [IN13] ²	Recessed equipment installed in building envelope assemblies does not compress the adjacent insulation.			<input type="checkbox"/> Complies <input type="checkbox"/> Does Not <input type="checkbox"/> Not Observable <input type="checkbox"/> Not Applicable	

1 High Impact (Tier 1) 2 Medium Impact (Tier 2) 3 Low Impact (Tier 3)

Section # & Req.ID	Insulation Inspection	Plans Verified Value	Field Verified Value	Complies?	Comments/Assumptions
5.8.1.7.1 [IN15] ²	Attics and mechanical rooms have insulation protected where adjacent to attic or equipment access.			<input type="checkbox"/> Complies <input type="checkbox"/> Does Not <input type="checkbox"/> Not Observable <input type="checkbox"/> Not Applicable	
5.8.1.7.2 [IN16] ²	Foundation vents do not interfere with insulation.			<input type="checkbox"/> Complies <input type="checkbox"/> Does Not <input type="checkbox"/> Not Observable <input type="checkbox"/> Not Applicable	
5.8.1.8 [IN17] ³	Insulation intended to meet the roof insulation requirements cannot be installed on top of a suspended ceiling. Mark this requirement compliant if insulation is installed accordingly.			<input type="checkbox"/> Complies <input type="checkbox"/> Does Not <input type="checkbox"/> Not Observable <input type="checkbox"/> Not Applicable	

Additional Comments/Assumptions:

1	High Impact (Tier 1)	2	Medium Impact (Tier 2)	3	Low Impact (Tier 3)
---	----------------------	---	------------------------	---	---------------------

Section # & Req.ID	Final Inspection	Complies?	Comments/Assumptions
5.4.3.3 [FI1] ¹	Weatherseals installed on all loading dock cargo doors in Climate Zones 4-8.	<input type="checkbox"/> Complies <input type="checkbox"/> Does Not <input type="checkbox"/> Not Observable <input type="checkbox"/> Not Applicable	
6.4.3.1.2 [FI3] ³	Thermostatic controls have a 5 °F deadband.	<input type="checkbox"/> Complies <input type="checkbox"/> Does Not <input type="checkbox"/> Not Observable <input type="checkbox"/> Not Applicable	
6.4.3.2 [FI20] ³	Temperature controls have setpoint overlap restrictions.	<input type="checkbox"/> Complies <input type="checkbox"/> Does Not <input type="checkbox"/> Not Observable <input type="checkbox"/> Not Applicable	
6.4.3.3.1 [FI21] ³	HVAC systems equipped with at least one automatic shutdown control.	<input type="checkbox"/> Complies <input type="checkbox"/> Does Not <input type="checkbox"/> Not Observable <input type="checkbox"/> Not Applicable	
6.4.3.3.2 [FI22] ³	Setback controls allow automatic restart and temporary operation as required for maintenance.	<input type="checkbox"/> Complies <input type="checkbox"/> Does Not <input type="checkbox"/> Not Observable <input type="checkbox"/> Not Applicable	
6.4.3.6 [FI6] ³	When humidification and dehumidification are provided to a zone, simultaneous operation is prohibited. Humidity control prohibits the use of fossil fuel or electricity to produce RH > 30% in the warmest zone humidified and RH < 60% in the coldest zone dehumidified.	<input type="checkbox"/> Complies <input type="checkbox"/> Does Not <input type="checkbox"/> Not Observable <input type="checkbox"/> Not Applicable	
6.7.2.1 [FI7] ³	Furnished HVAC as-built drawings submitted within 90 days of system acceptance.	<input type="checkbox"/> Complies <input type="checkbox"/> Does Not <input type="checkbox"/> Not Observable <input type="checkbox"/> Not Applicable	
6.7.2.2 [FI8] ³	Furnished O&M manuals for HVAC systems within 90 days of system acceptance.	<input type="checkbox"/> Complies <input type="checkbox"/> Does Not <input type="checkbox"/> Not Observable <input type="checkbox"/> Not Applicable	
6.7.2.3 [FI9] ¹	An air and/or hydronic system balancing report is provided for HVAC systems serving zones >5,000 ft ² of conditioned area.	<input type="checkbox"/> Complies <input type="checkbox"/> Does Not <input type="checkbox"/> Not Observable <input type="checkbox"/> Not Applicable	
6.7.2.4 [FI10] ¹	HVAC control systems have been tested to ensure proper operation, calibration and adjustment of controls.	<input type="checkbox"/> Complies <input type="checkbox"/> Does Not <input type="checkbox"/> Not Observable <input type="checkbox"/> Not Applicable	
7.4.4.3 [FI11] ³	Public lavatory faucet water temperature <=110°F.	<input type="checkbox"/> Complies <input type="checkbox"/> Does Not <input type="checkbox"/> Not Observable <input type="checkbox"/> Not Applicable	
8.7.1 [FI16] ³	Furnished as-built drawings for electric power systems within 30 days of system acceptance.	<input type="checkbox"/> Complies <input type="checkbox"/> Does Not <input type="checkbox"/> Not Observable <input type="checkbox"/> Not Applicable	

1 High Impact (Tier 1) 2 Medium Impact (Tier 2) 3 Low Impact (Tier 3)

Section # & Req.ID	Final Inspection	Complies?	Comments/Assumptions
8.7.2 [FI17] ³	Furnished O&M instructions for systems and equipment to the building owner or designated representative.	<input type="checkbox"/> Complies <input type="checkbox"/> Does Not <input type="checkbox"/> Not Observable <input type="checkbox"/> Not Applicable	
9.2.2.3 [FI18] ¹	Interior installed lamp and fixture lighting power is consistent with what is shown on the approved lighting plans, demonstrating proposed watts are less than or equal to allowed watts.	<input type="checkbox"/> Complies <input type="checkbox"/> Does Not <input type="checkbox"/> Not Observable <input type="checkbox"/> Not Applicable	<i>See the Interior Lighting fixture schedule for values.</i>
9.4.2 [FI19] ¹	Exterior lighting power is consistent with what is shown on the approved lighting plans, demonstrating proposed watts are less than or equal to allowed watts.	<input type="checkbox"/> Complies <input type="checkbox"/> Does Not <input type="checkbox"/> Not Observable <input type="checkbox"/> Not Applicable	<i>See the Exterior Lighting fixture schedule for values.</i>
9.4.4 [FI20] ¹	At least 75% of all permanently installed lighting fixtures in dwelling units have ≥ 55 lm/W efficacy or a ≥ 45 lm/W total luminaire efficacy.	<input type="checkbox"/> Complies <input type="checkbox"/> Does Not <input type="checkbox"/> Not Observable <input type="checkbox"/> Not Applicable	
10.4.3 [FI24] ²	Elevators are designed with the proper lighting, ventilation power, and standby mode.	<input type="checkbox"/> Complies <input type="checkbox"/> Does Not <input type="checkbox"/> Not Observable <input type="checkbox"/> Not Applicable	
7.4.3 [FI45] ²	First 8 ft of outlet piping in nonrecirculating storage system, or branch piping connected to recirculated, heat traced, or impedance heated piping is insulated.	<input type="checkbox"/> Complies <input type="checkbox"/> Does Not <input type="checkbox"/> Not Observable <input type="checkbox"/> Not Applicable	

Additional Comments/Assumptions:

1	High Impact (Tier 1)	2	Medium Impact (Tier 2)	3	Low Impact (Tier 3)
---	----------------------	---	------------------------	---	---------------------



HEAT GAINS (COOLING LOADS)

SENSIBLE HEAT GAINS:

A. SOLAR RADIATION THROUGH GLASS:
NORTHEASTSOUTHWEST

$$SRN := N_{glass} \cdot 30 \cdot SF \quad SRE := E_{glass} \cdot 44 \cdot SF \quad SRS := S_{glass} \cdot 56 \cdot SF \quad SRW := W_{glass} \cdot 158 \cdot SF$$

$$TOTAL \quad SR := SRN + SRE + SRS + SRW \quad SR = 1659$$

B. TRANSMISSION GAINS:

1. GLASS:

$$GA := N_{glass} + E_{glass} + S_{glass} + W_{glass} \quad GA = 63$$

2. DOORS:

$$TG := GA \cdot WU \cdot (OS - IS) \quad TG = 529$$

$$TWG := WD \cdot WU \cdot (OS - IS) \quad TWG = 336$$

$$TGD := GD \cdot GU \cdot (OS - IS) \quad TGD = 0$$

3. WALLS: FIND EQUIVALENT TEMPERATURE DIFFERENCE (ETD)
TEMPERATURE CORRECTION / DAILY RANGE CORRECTION:

$$TC := OS - IS - 20 \quad DRC := 0.5 \cdot (20 - DR) \quad ETD := TC + DRC \quad ETD = -5$$

NORTH / EAST / SOUTH / WEST

$$TWN := (NW - N_{glass}) \cdot UW \cdot (ETD + 15) \quad TWE := (EW - E_{glass}) \cdot UW \cdot (ETD + 36)$$

$$TWS := (SW - S_{glass}) \cdot UW \cdot (ETD + 23) \quad TWW := (WW - W_{glass}) \cdot UW \cdot (ETD + 17)$$

$$TOTAL \quad TW := TWN + TWE + TWS + TWW \quad TW = 2685$$

4. ROOF:

$$TR := R \cdot RU \cdot (OS - IS) \quad TR = 1295$$

5. FLOOR:

$$FR := F \cdot FU \cdot (OS - IS) \quad FR = 2073$$

$$TOTAL TRANSMISSION GAIN \quad T := TG + TWG + TGD + TW + TR + FR \quad T = 6919$$

C. OCCUPANTS: $SO := OC \cdot 230 \quad SO = 4140$

D. LIGHTS: $L := (IL \cdot 3.4) + (FL \cdot 4.1) \quad L = 6560$

E. VENTILATION: $SV := OC \cdot OA \cdot (OS - IS) \cdot 1.1 \quad SV = 1485$

F. DUCTS: $SD := (SR + T + SO + L + SV) \cdot 0.05 \quad SD = 1038$

G. EQUIPMENT: $EQ := EL \cdot F \quad EQ = 25907$

$$TOTAL SENSIBLE HEAT GAIN \quad SHG := SR + T + SO + L + SV + SD + EQ \quad SHG = 47708$$



LATENT HEAT GAINS:

A. OCCUPANTS:	$LO := OC \cdot 190$	$LO = 3420$
B. VENTILATION:	$LV := OC \cdot OA \cdot DG \cdot 0.68$	$LV = 2142$
TOTAL LATENT HEAT GAIN	$LHG := LO + LV$	$LHG = 5562$
TOTAL HEAT GAIN	$HG := SHG + LHG$	$HG = 53270$

BTUH

HEAT LOSS (HEATING LOADS)

A. TRANSMISSION LOSS:

1. GLASS:	$LTG := GA \cdot UG \cdot (IW - OW)$	$LTG = 2654$
2. DOORS:	$LTWD := WD \cdot WU \cdot (IW - OW)$	$LTWD = 1165$
3. WALLS:	$LTGD := GD \cdot GU \cdot (IW - OW)$	$LTGD = 0$
	$LTW := (NW + EW + SW + WW - GA) \cdot UW \cdot (IW - OW)$	$LTW = 6994$
4. ROOF:	$LR := R \cdot RU \cdot (IW - OW)$	$LR = 4491$
5. FLOOR:	$LF := F \cdot FU \cdot (IW - OW)$	$LF = 7185$
TOTAL TRANSMISSION LOSS	$LT := LTG + LTWD + LTGD + LTW + LR + LF$	$LT = 22488$

B. DUCTS:	$LD := LT \cdot 0.05$	$LD = 1124$
C. VENTILATION:	$LV := OC \cdot OA \cdot (IW - OW) \cdot 1.1$	$LV = 5148$

TOTAL HEAT LOSS	$HL := LT + LD + LV$	$HL = 28760$	BTUH
-----------------	----------------------	--------------	------

REFERENCE: ACCA MANUAL FOURTH EDITION



**R. JOHNSON
APPROVED
02 21 2023**



Job 95531	Truss SF351201	Truss Type SLOPING FLAT	Qty 1	Ply 1	Specialized Structures 316 GA Ref. #10002714
---------------------	--------------------------	-----------------------------------	-----------------	-----------------	--

Universal Forest Products Inc., Grand Rapids, MI 49525, Weston Gorby 8.220 e Aug 13 2018 MiTek Industries, Inc. Tue Mar 26 08:00:50 2019 Page 1 of 1

Copyright ©2019 Universal Forest Products, Inc. All Rights Reserved

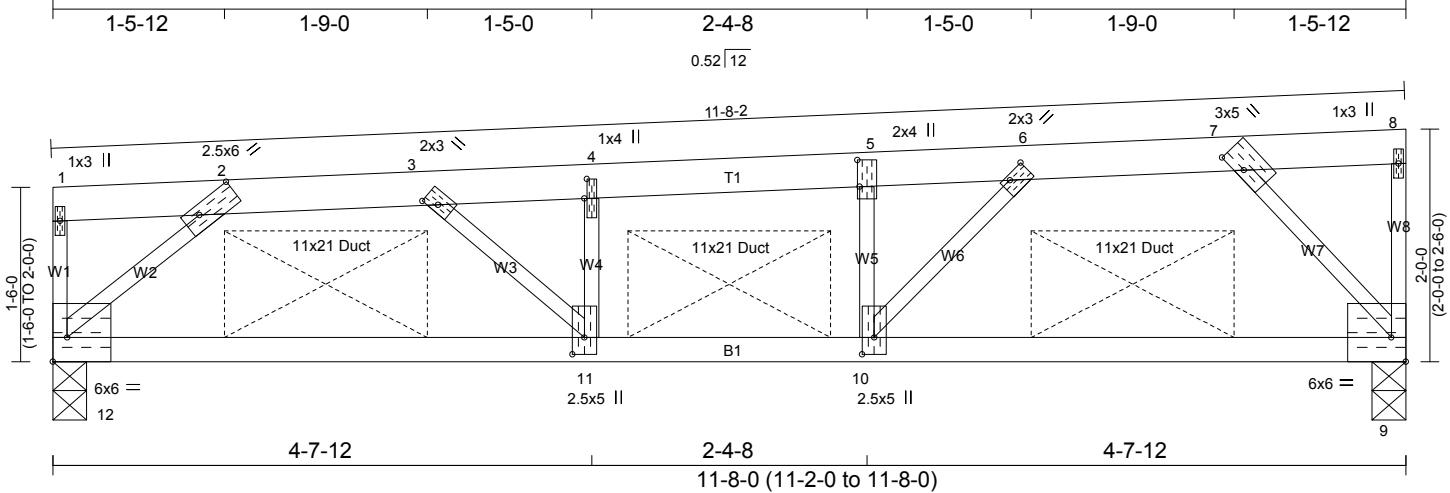

Plate Offsets (X,Y)-- [2:0-4-5,0-1-0], [3:0-1-8,0-0-12], [4:0-2-0,0-0-4], [5:0-2-12,0-0-4], [6:0-2-1,0-0-8], [7:0-2-8,0-0-12], [9:Edge,0-2-8], [10:0-1-12,0-1-4], [11:0-1-12,0-1-4], [12:Edge,0-2-8]

SPACING:- 2-0-0 LOADING (psf) TCLL 23.1 (Ground Snow=30.0) TCDL 7.0 BCLL 0.0 BCDL 7.0	SPACING:- 1-4-0 LOADING (psf) TCLL 34.7 (Ground Snow=45.0) TCDL 10.5 BCLL 0.0 BCDL 10.5	SPACING- 2-0-0 Plate Grip DOL 1.15 Lumber DOL 1.15 Rep Stress Incr YES Code IBC2018/TPI2014 IBC2015/TPI2014 IBC2012/TPI2007	CSI. TC 0.99 BC 0.50 WB 0.86 Matrix-R	DEFL. Vert(LL) 0.23 10-11 >592 240 Vert(CT) 0.22 10-11 >634 180 Horz(CT) -0.03 9 n/a n/a	PLATES GRIP MT20 244/190 Weight: 38 lb FT = 0%
---	---	--	--	--	--

LUMBER- TOP CHORD 2x4 SP No.1 BOT CHORD 2x3 SP No.2 WEBS 2x2 SP No.2	BRACING- TOP CHORD Structural wood sheathing directly applied, except end verticals. BOT CHORD Rigid ceiling directly applied or 3-1-6 oc bracing.
--	---

REACTIONS. (lb/size) 12=428/0-3-8 (min. 0-1-8), 9=428/0-3-8 (min. 0-1-8)
Max Horz 12=166(LC 8)
Max Uplift 12=-518(LC 7), 9=-513(LC 9)
Max Grav 12=490(LC 13), 9=490(LC 13)

FORCES. (lb) - Maximum Compression/Maximum Tension
TOP CHORD 1-12=-248/117, 1-2=-25/61, 2-3=-644/1641, 3-4=-925/2249, 4-5=-929/2275, 5-6=-939/2319, 6-7=-505/1313, 7-8=-26/93, 8-9=-331/143
BOT CHORD 11-12=-1535/630, 10-11=-2167/927, 9-10=-1202/515
WEBS 4-11=-253/669, 5-10=-417/1109, 2-12=-834/2078, 3-11=-886/417, 6-10=-1458/623, 7-9=-783/1996

- NOTES-**
- 1) Wind: ASCE 7-16; Vult=177mph (3-second gust) Vasd=140mph @24in o.c.; TCDL=2.8psf; BCDL=2.8psf; (Alt. 180mph @16in o.c.; TCDL=4.2psf; BCDL=4.2psf); h=30ft; Cat. II; Exp C; Enclosed; MWFRS (envelope) gable end zone and C-C Corner(3) zone; end vertical left and right exposed; C-C for members and forces & MWFRS for reactions shown; Lumber DOL=1.60 plate grip DOL=1.60
 - 2) TCLL: ASCE 7-16; Pg=30.0 psf; Ps=23.1 psf (Lum DOL=1.15 Plate DOL=1.15); Is=1.0; Rough Cat C; Partially Exp.; Ce=1.0; Cs=1.00; Ct=1.10
 - 3) Roof design snow load has been reduced to account for slope.
 - 4) Unbalanced snow loads have been considered for this design.
 - 5) This truss has been designed for a 10.0 psf bottom chord live load nonconcurrent with any other live loads.
 - 6) * This truss has been designed for a live load of 20.0psf on the bottom chord in all areas where a rectangle 3-6-0 tall by 2-0-0 wide will fit between the bottom chord and any other members.
 - 7) Provide mechanical connection (by others) of truss to bearing plate capable of withstanding 518 lb uplift at joint 12 and 513 lb uplift at joint 9.
 - 8) Fixity of members 12 - 1, 9 - 8 have been changed.
 - 9) This truss is designed in accordance with the 2018 International Building Code section 2306.1 and referenced standard ANSI/TPI 1.
 - 10) This truss is designed in accordance with the 2012 IBC Sec 2306.1 and referenced standard ANSI/TPI 1
 - 11) This truss is designed in accordance with the 2015 IBC Sec 2306.1 and referenced standard ANSI/TPI 1
 - 12) When adjusting the variable span dimension, adjust the post placement dimensions proportional to the change in span.



R. JOHNSON
APPROVED
02 21 2023



The professional engineering seal indicates that a licensed professional engineer has designed the truss under the standards referenced within this document, not necessarily the current state building code. The engineering seal is not an approval to use in a specific state. The final determination on whether a truss design is acceptable under the locally adopted building code rest with the building official or designated appointee.

3/2/2022

WARNING - Verify design parameters and READ NOTES

Truss shall not be cut or modified without approval of the truss design engineer.

This component has only been designed for the loads noted on this drawing. Construction and lifting forces have not been considered. The builder is responsible for lifting methods and system design. Builder responsibilities are defined under TPI1. This design is based only upon parameters shown, and is for an individual building component to be installed and loaded vertically. Applicability of design parameters and proper incorporation of component is responsibility of building designer - not truss designer. Bracing shown is for lateral support of individual web members only. Additional temporary bracing to insure stability during construction is the responsibility of the erector. Additional permanent bracing of the overall structure is the responsibility of the building designer. For general guidance regarding fabrication, quality control, storage, delivery, erection and bracing, consult BCSI 1-06 from the Wood Truss Council of America and Truss Plate Institute Recommendation available from WTCA, 6300 Enterprise LN, Madison, WI 53719 J:\support\MitekSupp\templates\lufp.tpe

Universal Forest Products, Inc. 2801 EAST BELTLINE RD, NE
PHONE (616)-364-6161 FAX (616)-365-0060 GRAND RAPIDS, MI 49525



UFP INDUSTRIES



R. JOHNSON
APPROVED
02 21 2023

Job	Truss	MFG	Customer
95531	SF351201	316	SPECIALIZED STRUCTURES

The professional engineering seal indicates that a licensed professional has reviewed the design under the standards referenced within this document, not necessarily the current state building code. The engineering seal is not an approval to use a design in a specific state. The final determination on whether a truss design is acceptable under the locally adopted building code rest with the building official or designated appointee.



Professional Certification. I hereby certify that these documents were prepared or approved by me, and that I am a duly licensed professional engineer under the laws of the State of Maryland, License No. 25531, Expiration Date: 10/20/2022



UFP INDUSTRIES



**R. JOHNSON
APPROVED
02 21 2023**

Job	Truss	MFG	Customer
95531	SF351201	316	SPECIALIZED STRUCTURES

The professional engineering seal indicates that a licensed professional has reviewed the design under the standards referenced within this document, not necessarily the current state building code. The engineering seal is not an approval to use a design in a specific state. The final determination on whether a truss design is acceptable under the locally adopted building code rest with the building official or designated appointee.



I hereby certify that this plan, specification, or report was prepared by me or under my direct supervision and that I am a duly Licensed Professional Engineer under the laws of the State of Minnesota.

PRINT NAME: STUART WALTER

SIGNATURE: *Stuart J. Walter*

DATE: 3/2/2022 LIC # 47774





UFP INDUSTRIES



**R. JOHNSON
APPROVED
02 21 2023**

Job	Truss	MFG	Customer
95531	SF351201	316	SPECIALIZED STRUCTURES

The professional engineering seal indicates that a licensed professional has reviewed the design under the standards referenced within this document, not necessarily the current state building code. The engineering seal is not an approval to use a design in a specific state. The final determination on whether a truss design is acceptable under the locally adopted building code rest with the building official or designated appointee.



3/2/2022



2018 APPENDIX B

BUILDING CODE SUMMARY FOR ALL COMMERCIAL PROJECTS (EXCEPT 1 AND 2-FAMILY DWELLINGS AND TOWNHOUSES)

(Reproduce the following data on the building plans sheet 1 or 2)

MODULAR BUILDING PLAN NUMBER : FSS-10912

Name of Project: _____
 Address: _____ Zip Code _____
 Owner/Authorized Agent: _____ Phone # (_____) _____ - _____ E-Mail _____
 Owned By: City/County Private State
 Code Enforcement Jurisdiction: City _____ County _____ State

CONTACT:

KENNETH EARL DUNMON - NC PE # 017400 - FOR MODULAR UNITS ONLY

DESIGNER	FIRM	NAME	LICENSE #	TELEPHONE #	E-MAIL
Architectural	_____	_____	_____	() _____	_____
Civil	_____	_____	_____	() _____	_____
Electrical	_____	_____	_____	() _____	_____
Fire Alarm	_____	_____	_____	() _____	_____
Plumbing	_____	_____	_____	() _____	_____
Mechanical	_____	_____	_____	() _____	_____
Sprinkler-Standpipe	_____	_____	_____	() _____	_____
Structural	_____	_____	_____	() _____	_____
Retaining Walls >5' High	_____	_____	_____	() _____	_____
Other	_____	_____	_____	() _____	_____

("Other" should include firms and individuals such as truss, precast, pre-engineered, interior designers, etc.)

2018 NC BUILDING CODE: New Building Addition Renovation
 1st Time Interior Completion
 Shell/Core - Contact the local inspection jurisdiction for possible additional procedures and requirements
 Phased Construction - Shell/Core- Contact the local inspection jurisdiction for possible additional procedures and requirements

2018 NC EXISTING BUILDING CODE: EXISTING: Prescriptive Repair Chapter 14
 Alteration: Level I Level II Level III
 Historic Property Change of Use

CONSTRUCTED: (date) _____ **CURRENT OCCUPANCY(S)** (Ch. 3): _____

RENOVATED: (date) _____ **PROPOSED OCCUPANCY(S)** (Ch. 3): _____

RISK CATEGORY (Table 1604.5): **Current:** I II III IV
Proposed: I II III IV

BASIC BUILDING DATA

Construction Type: I-A II-A III-A IV V-A
 (check all that apply) I-B II-B III-B V-B
Sprinklers: No Partial Yes NFPA 13 NFPA 13R NFPA 13D
Standpipes: No Yes Class I II III Wet Dry
Fire District: No Yes **Flood Hazard Area:** No Yes
Special Inspections Required: No Yes (Contact the local inspection jurisdiction for additional procedures and requirements.)



**R. JOHNSON
APPROVED
02 21 2023**

Gross Building Area Table

FLOOR	EXISTING (SQ FT)	NEW (SQ FT)	SUB-TOTAL
3 rd Floor			
2 nd Floor			
Mezzanine			
1 st Floor		1727	
Basement			
TOTAL		1727	

ALLOWABLE AREA

Primary Occupancy Classification(s): Select one Select one Select one Select one Select one Select one

- Assembly A-1 A-2 A-3 A-4 A-5
- Business
- Educational
- Factory F-1 Moderate F-2 Low
- Hazardous H-1 Detonate H-2 Deflagrate H-3 Combust H-4 Health H-5 HPM
- Institutional I-1 Condition 1 2
 - I-2 Condition 1 2
 - I-3 Condition 1 2 3 4 5
 - I-4
- Mercantile
- Residential R-1 R-2 R-3 R-4
- Storage S-1 Moderate S-2 Low High-piled
 - Parking Garage Open Enclosed Repair Garage
- Utility and Miscellaneous

Accessory Occupancy Classification(s): _____

Incidental Uses (Table 509): _____

Special Uses (Chapter 4 – List Code Sections): _____

Special Provisions: (Chapter 5 – List Code Sections): _____

Mixed Occupancy: No Yes Separation: 0 Hr. Exception: _____

Non-Separated Use (508.3) - The required type of construction for the building shall be determined by applying the height and area limitations for each of the applicable occupancies to the entire building. The most restrictive type of construction, so determined, shall apply to the entire building.

Separated Use (508.4) - See below for area calculations for each story, the area of the occupancy shall be such that the sum of the ratios of the actual floor area of each use divided by the allowable floor area for each use shall not exceed 1.

$$\frac{\text{Actual Area of Occupancy A}}{\text{Allowable Area of Occupancy A}} + \frac{\text{Actual Area of Occupancy B}}{\text{Allowable Area of Occupancy B}} \leq 1$$

$$\underline{\hspace{2cm}} + \underline{\hspace{2cm}} + \dots = \underline{\hspace{2cm}} \leq 1.00$$



STORY NO.	DESCRIPTION AND USE	(A) BLDG AREA PER STORY (ACTUAL)	(B) TABLE 506.2 ⁴ AREA	(C) AREA FOR FRONTAGE INCREASE ^{1,5}	(D) ALLOWABLE AREA PER STORY OR UNLIMITED ^{2,3}
1	OFFICE	1727	9000	NOT USED	9000

¹ Frontage area increases from Section 506.2 are computed thus:

- a. Perimeter which fronts a public way or open space having 20 feet minimum width = _____ (F)
- b. Total Building Perimeter = _____ (P)
- c. Ratio (F/P) = _____ (F/P)
- d. W = Minimum width of public way = _____ (W)
- e. Percent of frontage increase $I_f = 100[F/P - 0.25] \times W/30 =$ _____ (%)

² Unlimited area applicable under conditions of Section 507.

³ Maximum Building Area = total number of stories in the building x D (maximum 3 stories) (506.2).

⁴ The maximum area of open parking garages must comply with Table 406.5.4. The maximum area of air traffic control towers must comply with Table 412.3.1.

⁵ Frontage increase is based on the unsprinklered area value in Table 506.2.

ALLOWABLE HEIGHT

	ALLOWABLE	SHOWN ON PLANS	CODE REFERENCE
Building Height in Feet (Table 504.3)	40	15	
Building Height in Stories (Table 504.4)	2	1	

¹ Provide code reference if the "Shown on Plans" quantity is not based on Table 504.3 or 504.4.



FIRE PROTECTION REQUIREMENTS

BUILDING ELEMENT	FIRE SEPARATION DISTANCE (FEET)	RATING		DETAIL # AND SHEET #	DESIGN # FOR RATED ASSEMBLY	SHEET # FOR RATED PENETRATION	SHEET # FOR RATED JOINTS
		REQ'D	PROVIDED (w/ REDUCTION) *				
Structural Frame, including columns, girders, trusses		N/A					
Bearing Walls							
Exterior		N/A					
North		N/A					
East		N/A					
West		N/A					
South		N/A					
Interior		N/A					
Nonbearing Walls and Partitions							
Exterior walls							
North		N/A					
East		N/A					
West		N/A					
South		N/A					
Interior walls and partitions		N/A					
Floor Construction		N/A					
Including supporting beams and joists		N/A					
Floor Ceiling Assembly		N/A					
Columns Supporting Floors		N/A					
Roof Construction, including supporting beams and joists		N/A					
Roof Ceiling Assembly		N/A					
Columns Supporting Roof		N/A					
Shaft Enclosures - Exit		N/A					
Shaft Enclosures - Other		N/A					
Corridor Separation		N/A					
Occupancy/Fire Barrier Separation		N/A					
Party/Fire Wall Separation		N/A					
Smoke Barrier Separation		N/A					
Smoke Partition		N/A					
Tenant/Dwelling Unit/ Sleeping Unit Separation		N/A					
Incidental Use Separation		N/A					

* Indicate section number permitting reduction



PERCENTAGE OF WALL OPENING CALCULATIONS

FIRE SEPARATION DISTANCE (FEET) FROM PROPERTY LINES	DEGREE OF OPENINGS PROTECTION (TABLE 705.8)	ALLOWABLE AREA (%)	ACTUAL SHOWN ON PLANS (%)
30'	N/A		

LIFE SAFETY SYSTEM REQUIREMENTS

- Emergency Lighting: No Yes
- Exit Signs: No Yes
- Fire Alarm: No Yes
- Smoke Detection Systems: No Yes Partial _____
- Carbon Monoxide Detection: No Yes

LIFE SAFETY PLAN REQUIREMENTS

Life Safety Plan Sheet #: NOT INCLUDED WITHIN THE MODULAR BLDG PLAN SET. TO BE PROVIDED BY PERMIT APPLICANT - APPLICABLE INFO IS ON SHEETS 1 & 2

- Fire and/or smoke rated wall locations (Chapter 7)
- Assumed and real property line locations (if not on the site plan)
- Exterior wall opening area with respect to distance to assumed property lines (705.8)
- Occupancy Use for each area as it relates to occupant load calculation (Table 1004.1.2)
- Occupant loads for each area
- Exit access travel distances (1017)
- Common path of travel distances (Tables 1006.2.1 & 1006.3.2(1))
- Dead end lengths (1020.4)
- Clear exit widths for each exit door
- Maximum calculated occupant load capacity each exit door can accommodate based on egress width (1005.3)
- Actual occupant load for each exit door
- A separate schematic plan indicating where fire rated floor/ceiling and/or roof structure is provided for purposes of occupancy separation
- Location of doors with panic hardware (1010.1.10)
- Location of doors with delayed egress locks and the amount of delay (1010.1.9.7)
- Location of doors with electromagnetic egress locks (1010.1.9.9)
- Location of doors equipped with hold-open devices
- Location of emergency escape windows (1030)
- The square footage of each fire area (202)
- The square footage of each smoke compartment for Occupancy Classification I-2 (407.5)
- Note any code exceptions or table notes that may have been utilized regarding the items above



**ACCESSIBLE DWELLING UNITS
(SECTION 1107)**

NOT APPLICABLE

TOTAL UNITS	ACCESSIBLE UNITS REQUIRED	ACCESSIBLE UNITS PROVIDED	TYPE A UNITS REQUIRED	TYPE A UNITS PROVIDED	TYPE B UNITS REQUIRED	TYPE B UNITS PROVIDED	TOTAL ACCESSIBLE UNITS PROVIDED

**ACCESSIBLE PARKING
(SECTION 1106)**

NOT APPLICABLE: PROVIDED BY SITE DESIGNER

LOT OR PARKING AREA	TOTAL # OF PARKING SPACES		# OF ACCESSIBLE SPACES PROVIDED			TOTAL # ACCESSIBLE PROVIDED
	REQUIRED	PROVIDED	REGULAR WITH 5' ACCESS AISLE	VAN SPACES WITH		
				132" ACCESS AISLE	8' ACCESS AISLE	
TOTAL						

**PLUMBING FIXTURE REQUIREMENTS
(TABLE 2902.1)**

USE		WATERCLOSETS			URINALS	LAVATORIES			SHOWERS /TUBS	DRINKING FOUNTAINS	
		MALE	FEMALE	UNISEX		MALE	FEMALE	UNISEX		REGULAR	ACCESSIBLE
SPACE	EXIST'G										
	NEW	2	1		1	2	1			0	0
	REQ'D	1	1			1	1			1	1

DRINKING FACILITIES TO BE PROVIDED ON SITE SUBJECT TO APPROVAL OF THE AHJ

SPECIAL APPROVALS

Special approval: (Local Jurisdiction, Department of Insurance, OSC, DPI, DHHS, etc., describe below)



ENERGY SUMMARY

ENERGY REQUIREMENTS:

The following data shall be considered minimum and any special attribute required to meet the energy code shall also be provided. Each Designer shall furnish the required portions of the project information for the plan data sheet. If performance method, state the annual energy cost for the standard reference design vs annual energy cost for the proposed design.

Existing building envelope complies with code: No Yes (The remainder of this section is not applicable)

Exempt Building: No Yes (Provide code or statutory reference): _____

Climate Zone: 3A 4A 5A

Method of Compliance: Energy Code Performance Prescriptive
ASHRAE 90.1 Performance Prescriptive
(If "Other" specify source here) _____

THERMAL ENVELOPE (Prescriptive method only)

Roof/ceiling Assembly (each assembly)

Description of assembly: ATTIC WITH WOOD JOIST/TRUSS
U-Value of total assembly: 0.017
R-Value of insulation: R-60
Skylights in each assembly: N/A
 U-Value of skylight: N/A
total square footage of skylights in each assembly: N/A

Exterior Walls (each assembly)

Description of assembly: WOOD FRAMED @ 16" O.C.
U-Value of total assembly: 0.067
R-Value of insulation: R-19
Openings (windows or doors with glazing)
 U-Value of assembly: 0.34
 Solar heat gain coefficient: 0.24
 projection factor: N/A
 Door R-Values: U = 0.153

Walls below grade (each assembly)

Description of assembly: N/A
U-Value of total assembly: _____
R-Value of insulation: _____

Floors over unconditioned space (each assembly)

Description of assembly: WOOD FRAMED
U-Value of total assembly: 0.038
R-Value of insulation: R-30

Floors slab on grade

Description of assembly: N/A
U-Value of total assembly: _____
R-Value of insulation: _____
Horizontal/vertical requirement: _____
slab heated: _____



**R. JOHNSON
APPROVED
02 21 2023**

2018 APPENDIX B
BUILDING CODE SUMMARY FOR ALL COMMERCIAL PROJECTS
STRUCTURAL DESIGN
(PROVIDE ON THE STRUCTURAL SHEETS IF APPLICABLE)

DESIGN LOADS:

Importance Factors: Snow (I_S) 1.0
Seismic (I_E) 1.0

Live Loads: Roof 20 psf
Mezzanine _____ psf
Floor 100 psf

Ground Snow Load: 20 psf

Wind Load: Ultimate Wind Speed 130 mph (ASCE-7)
Exposure Category C

SEISMIC DESIGN CATEGORY: A B C D

Provide the following Seismic Design Parameters:

Risk Category (Table 1604.5) I II III IV
Spectral Response Acceleration S_S 0.19 %g S_1 0.088 %g

Site Classification (ASCE 7) A B C D E F

Data Source: Field Test Presumptive Historical Data

Basic structural system Bearing Wall Dual w/Special Moment Frame
 Building Frame Dual w/Intermediate R/C or Special Steel
 Moment Frame Inverted Pendulum

Analysis Procedure: Simplified Equivalent Lateral Force Dynamic

Architectural, Mechanical, Components anchored? Yes No

LATERAL DESIGN CONTROL: Earthquake Wind

SOIL BEARING CAPACITIES:

Field Test (provide copy of test report) _____ psf
Presumptive Bearing capacity 2,000 psf
Pile size, type, and capacity _____



R. JOHNSON
APPROVED
02 21 2023

2018 APPENDIX B
BUILDING CODE SUMMARY FOR ALL COMMERCIAL PROJECTS
MECHANICAL DESIGN
(PROVIDE ON THE MECHANICAL SHEETS IF APPLICABLE)

MECHANICAL SUMMARY

MECHANICAL SYSTEMS, SERVICE SYSTEMS AND EQUIPMENT

Thermal Zone

winter dry bulb: 20
summer dry bulb: 93

Interior design conditions

winter dry bulb: 72
summer dry bulb: 78
relative humidity: 50

Building heating load: 28760

Building cooling load: 53270

Mechanical Spacing Conditioning System

Unitary

description of unit: _____
heating efficiency: _____
cooling efficiency: _____
size category of unit: _____

Boiler

Size category. If oversized, state reason.: _____

Chiller

Size category. If oversized, state reason.: _____

List equipment efficiencies: 11.0 EER (SPVAC)



R. JOHNSON
APPROVED
02 21 2023

