

VICINITY MAP

WOODGROVE AMENITY BATHHOUSE & POOL HARNETT COUNTY, NC

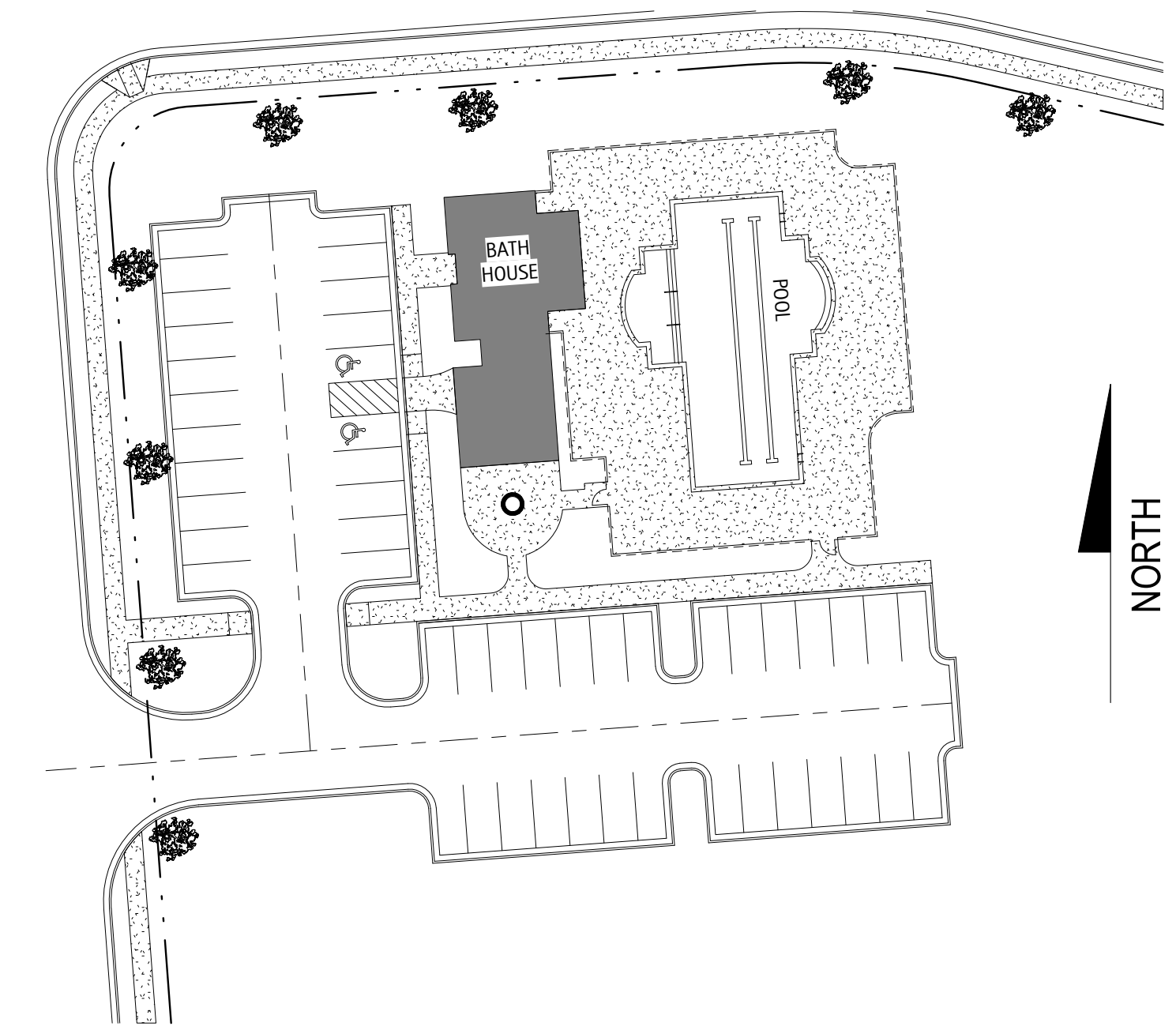

SITE MAP

SYMBOLS

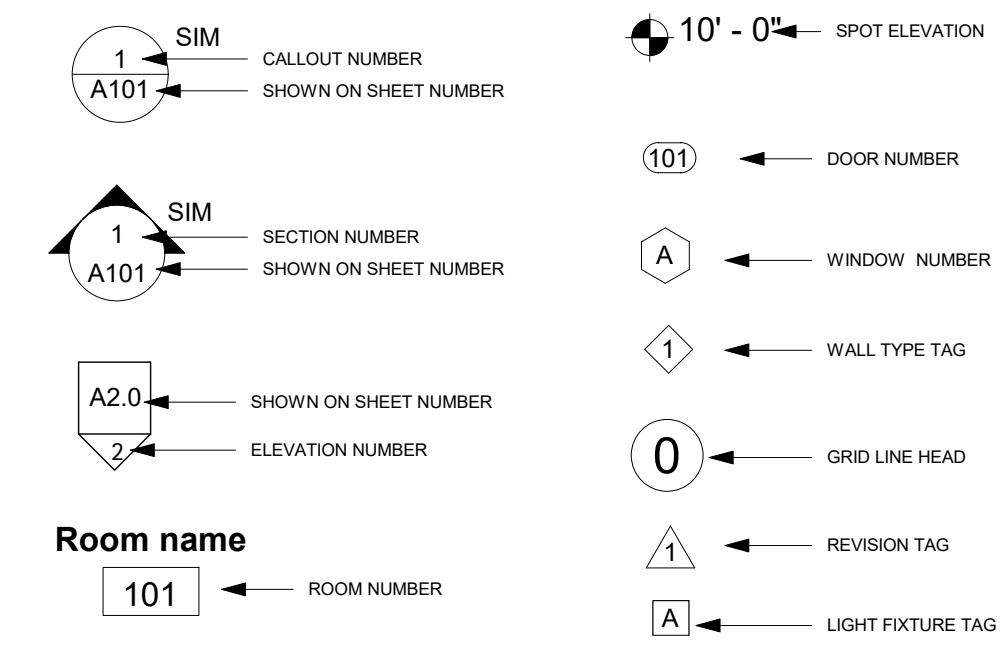

DRAWING INDEX

- G0.1 Cover Sheet
- G0.2 Appendix B
- G0.3 Life Safety Plan
- G0.4 General Notes
- A1.0 Foundation Plans & Details
- A1.1 First Floor Plan
- A1.2 RCP & Roof Plans
- A2.0 Exterior Elevations
- A2.1 Exterior Elevations
- A3.0 Building Sections
- A3.1 Wall Sections & Details
- A4.0 General Building Details
- A5.0 Schedules & Details
- S1 Slab & Foundation Plan
- S2 Ceiling Framing Plans
- S3 Roof Framing Plan
- S4 Structural Notes & Details

DRAWING INDEX

- P1 Plumbing Notes & Schedules
- P2 Sanitary & Water Supply Plans
- P3 Plumbing Risers
- M1 Mechanical Notes, Plans, & Schedules
- E1 Electrical Notes & Schedules
- E2 Lighting & Power Plans
- E3 Panel Schedules & Risers
- SP1 Pool Dimension Plan
- SP2 Pool Layout Plan
- SP3 Piping & Electrical Plan
- SP4 Enlarged Pump Room & Pool Section
- SP5 Sections & Details
- SP6 Specifications
- SP7 Specifications
- SP8 Specifications



Perry Cox
architect, p.a.
124 Salem Towne Court, Apex, NC 27502
P: 919.363.5411
www.pcoxdesign.com

DATE	
REVISION	
NO.	

SHEET DISCRPTION
Cover Sheet

PROJECT #:	2022002
DATE ISSUED:	07/20/2022
DRAWING BY:	JGM/BSJ
CHECKED BY:	PBC/JSC

**WOODGROVE
DR HORTON
BATHHOUSE & POOL
HARNETT COUNTY, NC**

G0.1

Kilian Engineering, Inc.
481 E. MAIN STREET - CLAYTON, NC 27520
P: 262.438.8778

ROSS LINDEN ENGINEERS PC
709 W. JONES STREET - RALEIGH, NC 27603
P: 919.832.5680 FAX 919.832.5675
INFO@ROSSLINDEN.COM

D. CLUGSTON
THE BUILDING & DEVELOPMENT CO.
2506 RELIANCE AVE. APEX, NC 27539
(P) 919.629.7290
WWW.DCLUGSTON.COM

POOL DECK NON-ACCESSIBLE AREA
3,475 SQ FT / 15 SQ FT PER PERSON:
232 PEOPLE

8' CLEAR DECK AREA
2,086 SQ FT / 15 SQ FT PER PERSON:
140 PEOPLE

POOL AREA
2,390 SQ FT / 50 SQ FT PER PERSON:
48 PEOPLE

COVERED PORCH:
415 SQ FT / 15 SQ FT PER PERSON:
28 PEOPLE

**TOTAL A-3 OCCUPANT LOAD
(INSIDE FENCE):**
448 PEOPLE

48" COMMERCIAL GRADE GATE. ALL GATE POST TO BE 4x4 SQ STEEL, PRIMED AND PAINTED BLACK. SEE FENCE DETAIL ON SP4.8
ALL ACCESS POINTS MUST BE SELF CLOSING & LATCHING WITH PANIC HARDWARE AT ALL EXITS.

125 OCC.
(1) 48" GATE = 46" CLEAR HORIZONTAL EXIT
46"/2 = 230 MAX OCC. PER NCSBC 1005

48" COMMERCIAL GRADE GATE. ALL GATE POST TO BE 4x4 SQ STEEL, PRIMED AND PAINTED BLACK. SEE FENCE DETAIL ON SP4.8
ALL ACCESS POINTS MUST BE SELF CLOSING & LATCHING WITH PANIC HARDWARE AT ALL EXITS.

124 OCC.
(1) 48" GATE = 46" CLEAR HORIZONTAL EXIT
46"/2 = 230 MAX OCC. PER NCSBC 1005

48" COMMERCIAL GRADE GATE. ALL GATE POST TO BE 4x4 SQ STEEL, PRIMED AND PAINTED BLACK. SEE FENCE DETAIL ON SP4.8
ALL ACCESS POINTS MUST BE SELF CLOSING & LATCHING WITH PANIC HARDWARE AT ALL EXITS.

125 OCC.
(1) 48" GATE = 46" CLEAR HORIZONTAL EXIT
46"/2 = 230 MAX OCC. PER NCSBC 1005

48" COMMERCIAL GRADE GATE. ALL GATE POST TO BE 4x4 SQ STEEL, PRIMED AND PAINTED BLACK. SEE FENCE DETAIL ON SP4.8
ALL ACCESS POINTS MUST BE SELF CLOSING & LATCHING WITH PANIC HARDWARE AT ALL EXITS.

125 OCC.
(1) 48" GATE = 46" CLEAR HORIZONTAL EXIT
46"/2 = 230 MAX OCC. PER NCSBC 1005

MAX ALLOWABLE TRAVEL DISTANCE: 200'-0"
ACTUAL TRAVEL DISTANCE: 111'-3"

125 OCC.
(1) 48" GATE = 46" CLEAR HORIZONTAL EXIT
46"/2 = 230 MAX OCC. PER NCSBC 1005

48" COMMERCIAL GRADE GATE. ALL GATE POST TO BE 4x4 SQ STEEL, PRIMED AND PAINTED BLACK. SEE FENCE DETAIL ON SP4.8
ALL ACCESS POINTS MUST BE SELF CLOSING & LATCHING WITH PANIC HARDWARE AT ALL EXITS.

48" COMMERCIAL GRADE GATE. ALL GATE POST TO BE 4x4 SQ STEEL, PRIMED AND PAINTED BLACK. SEE FENCE DETAIL ON SP4.8
ALL ACCESS POINTS MUST BE SELF CLOSING & LATCHING WITH PANIC HARDWARE AT ALL EXITS.

125 OCC.
(1) 48" GATE = 46" CLEAR HORIZONTAL EXIT
46"/2 = 230 MAX OCC. PER NCSBC 1005

POOL
2,390 SQ. FT.

MAX ALLOWABLE TRAVEL DISTANCE: 200'-0"
ACTUAL TRAVEL DISTANCE: 123'-10"

SAFETY EQUIPMENT LIFE HOOK & POLE, THROW ROPE, 24" LIFE RING

GENERAL LIFE SAFETY NOTES:

USE:
PRIMARY LOAD FACTOR:
OCCUPANT LOAD:
CONSTRUCTION TYPE:
SPRINKLERS:

A-3 (ASSEMBLY)
UNCONCENTRATED TABLES & CHAIRS (15 SF)
499 PPL
V-B
NO

REQUIRED EXITS:
PROVIDED EXITS:

2
4

DIAGONAL DISTANCE:
REQUIRED EXIT SEPARATION:
PROVIDED EXIT SEPARATION:

134'-0"
134'-0"/2 = 67'-0"
114'-5"

REQUIRED EGRESS WIDTH:
PROVIDED EGRESS WIDTH:

99.8"
184"

MAXIMUM COMMON PATH OF TRAVEL:
MAXIMUM ALLOWABLE TRAVEL DISTANCE:
ACTUAL MAX TRAVEL DISTANCE:

75'-0"
200'-0"
123'-10"

GENERAL PLUMBING NOTES:

USE:
OCCUPANT LOAD:

A-3 (ASSEMBLY)
499 PPL / 2 = 250 PPL

REQUIRED MALE WATER CLOSETS:
REQUIRED FEMALE WATER CLOSETS:
PROVIDED MALE WATER CLOSETS:
PROVIDED FEMALE WATER CLOSETS:

2 (1 PER 125 PPL)
4 (1 PER 65 PPL)
2 WC & 1 URINAL
4

REQUIRED MALE LAVATORIES:
REQUIRED FEMALE LAVATORIES:
PROVIDED MALE LAVATORIES:
PROVIDED FEMALE LAVATORIES:

2 (1 PER 200)
2 (1 PER 200)
2
2

REQUIRED WATERCOOLERS:
PROVIDED WATERCOOLERS:

2 (1 PER 500)
2

REQUIRED SERVICE SINKS:
PROVIDED SERVICE SINKS:

1
1(HOSE BIB & FLOOR DRAIN)

LIFE SAFETY SYMBOL LEGEND	
	EMERGENCY EXIT
FEX	SEMI-RECESSED 'ABC' TYPE FIRE EXTINGUISHER TO MEET NFPA-10 STANDARDS. MOUNT @ 15" MIN. - 48" MAX A.F.F.
FEX-C	BRACKET MOUNTED WATER TYPE FIRE EXTINGUISHER TO MEET NFPA-10 STANDARDS. MOUNT @ 15" MIN. - 48" MAX A.F.F.
	INDICATES TRAVEL DIRECTION

1
G0.3 **Life Safety Plan**
3/16" = 1'-0"

OCCUPANCY SCHEDULE CLUBHOUSE					
Room Number	Room Name	Type	Occupancy		
			Area	Load Factor	Load Count
100	ENTRY	N/A	31 SF	0 SF	
101	HALL	N/A	123 SF	0 SF	
103	ELEC.	Accessory Storage Areas, Mechanical Equipment Room	11 SF	300 SF	1
104	MENS	N/A	164 SF	0 SF	
105	PUMP ROOM	Accessory Storage Areas, Mechanical Equipment Room	156 SF	300 SF	1
106	WOMENS	N/A	162 SF	0 SF	
107	CHEM.	Accessory Storage Areas, Mechanical Equipment Room	43 SF	300 SF	1
108	COVERED PORCH	Assembly - Unconcentrated (tables and chairs)	415 SF	15 SF	28
109	COVERED PAVILLION	Assembly - Unconcentrated (tables and chairs)	708 SF	15 SF	48
Grand total			1813 SF		79

OCCUPANCY SCHEDULE POOL					
Room Number	Room Name	Type	Occupancy		
			Area	Load Factor	Load Count
PL100	POOL	Swimming Pool water surface	2390 SF	50 SF	48
PL101	POOL DECK CLEAR AREA	Swimming Pool Deck	2086 SF	15 SF	140
PL102	POOL DECK	Swimming Pool Deck	3475 SF	15 SF	232
Grand total			7951 SF		420



D. CLUGSTON

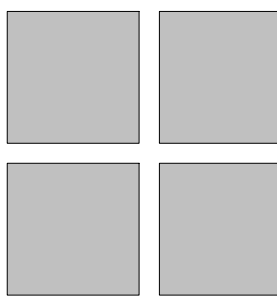

Perry Cox
architect, p.a.

124 Salem Towne Court, Apex, NC 27502
P. 919.363.5411
www.pcoxdesign.com

DATE

REVISION

NO.

SHEET DISCRPTION

Life Safety Plan

PROJECT #: 2022002

DATE ISSUED: 07/20/2022

DRAWING BY: JGM/BSJ

CHECKED BY: PGC/DSC

**WOODGROVE
DR HORTON
BATHHOUSE & POOL
HARNETT COUNTY, NC**

G0.3

GENERAL NOTES

- The General Contractor shall be both licensed and bonded in North Carolina and shall provide documents upon the Architect's request.
- The Work shall be done in accordance with all rules and regulations of the North Carolina State Building Code 2018 along with city, county, and state regulations. The General Contractor is responsible for securing and paying for all permits required for the Work and for the scheduling of all required inspections during the course of the Work.
- General Contractor shall be responsible for the provisions for job safety. These drawings do not contain provisions for job safety.
- Dimensions are to face of framing unless otherwise noted.
- Do not scale drawings. Stated & written dimensions govern. The General Contractor shall verify all dimensions in the field and shall be responsible for their accuracy. No extra charge or compensation shall be allowed because of difference between actual dimensions and those indicated on the drawings, unless they contribute to a change in the scope of the Work. Any difference which may be found shall be submitted to the Architect for decision prior to ordering, manufacturing, or proceeding with the Work. Horizontal dimensions indicated are to/from face of finish, unless noted otherwise. Vertical dimensions are from top of floor slab except where noted to be above finished floor (AFF). Dimensions are not adjustable without approval of Architect unless noted +/-.
- General Contractor shall be responsible for comparing all dimensions in the construction documents and existing conditions in the field.
- Framing Subcontractor shall coordinated framing with locations of HVAC vents, plumbing and light fixtures so as to avoid conflict.
- The General Contractor shall provide protection and be responsible for any existing finishes to remain and shall repair or replace any damaged areas as a result of the work. All existing finishes to remain shall be cleaned at the completion of construction.
- All materials and systems shall be installed as per manufacturer's specifications and all construction shall be of industry standard or better. The Architect shall be ultimate judge of quality.
- Only new items of recent manufacture, of standard quality, free from defects, will be permitted in the Work, unless otherwise noted. Rejected items shall be removed immediately from the Work and replaced with items of the quality specified. Failure to remove rejected materials and equipment shall not relieve the General Contractor from the responsibility for quality of items used nor from any other obligation imposed on him by the Contract.
- General Contractor shall be responsible for notifying the Architect immediately of construction deviating from depicted or implied information here-in. In the event of conflict between data shown on drawings and data shown in the specification, the specification shall govern. Detail drawings take precedence over drawings of larger scope. Should the General Contractor at any time discover an error in a drawing or specification, or any discrepancy, or variation between dimensions on the drawings and measurements at site, or lack of dimensions or other information, the Contractor shall not proceed with the work affected until clarification has been made by the Architect. In case of an inconsistency between Drawings and Specifications or within either Document, not clarified by addendum, the more specific provision will take precedence over less specific; more specific will take precedence over less stringent; more expensive item will take precedence over less expensive. Better quality or greater quantity of Work shall be provided in accordance with Architect's interpretation. On Drawings, figures take precedence over scaled dimensions. Scaling of dimensions, if done, is done at the Contractor's own risk.
- General Contractor shall verify that no conflicts exist in locations of any and all mechanical, telephone, electrical, plumbing and sprinkler equipment (to include all piping, duct work, sprinklers structural members and conduit) and that clearances for installation and maintenance of above equipment is provided. Elements in conflict shall be determined and reviewed with the Architect prior to work proceeding. Contractor to coordinate new work with existing conditions.
- The General Contractor shall provide shop drawings for the Architect's review and approval for the following: All shop fabricated millwork, carpet layout, flooring, light fixtures, doors, misc. steel, metal fabrication, glass/azing, sprinkler layouts, hardware. Shop drawings shall be submitted in the form of 3 sets of prints. Shop drawings shall not be reproductions of Contract Documents. Material Submittals (3 samples) shall be provided for wood, fasteners, acrylic, carpet, tile, base, paint, laminate and any other materials indicated in the shop drawing.
- The General Contractor shall provide the Architect with manufacturer's cut sheets and specifications for all equipment including but not limited to: light fixtures, plumbing equipment, electrical equipment, fans, supplementary heating and cooling elements, all hardware and security equipment. General contractor shall be responsible for verifying all field dimensions prior to ordering equipment and/or casework.
- The General Contractor shall not proceed with work for which he expects additional compensation beyond the contract amount with out written authorization from the Architect and Owner. Failure to obtain such authorization shall invalidate a claim for extra compensation. The Contractor shall not proceed with work which, if completed in strict conformance with the Construction Documents, will result in additional work beyond the scope of the Contract without written authorization from the Architect and Owner. Any field conditions that significantly vary from the Contract Documents or will result in additional work, shall be brought to the attention of the Architect prior to proceeding with work.
- Contractor shall include all x-ray and core drill costs. All core drilling of the slab shall be approved by the Landlord's Structural Engineer prior to proceeding with the Work. Contractor shall submit proposed locations to Architect and Structural Engineer for review prior to proceeding with the work.
- Patch, repair and install all fireproofing as required by code. Fireproof any new penetrations required by the work.
- General Contractor to coordinate and review size and location of all slab penetrations. All required penetrations shall be made in accordance with the Owner's standard approval procedures and methods. All penetrations shall be properly sealed according to the Architect and the Owner's requirements and applicable codes.
- The General Contractor shall continuously check architectural and structural clearances for accessibility of equipment and mechanical and electrical systems. No allowances of any kind will be made for the General Contractor's negligence to foresee means of installing equipment into position.
- The finished work shall be firm, well-anchored, in true alignment, plumb, level, with smooth, clean, uniform, appearance without waves, distortions, holes, marks cracks, stains, or discoloration. Joining shall be close fitting, neat and well scribed. The finished work shall have no exposed unsightly anchors or fasteners and shall not present hazardous, unsafe corners. All work shall have the provision for expansion, contraction and shrinkage as necessary to prevent cracks, buckling, and warping due to temperature and humidity conditions.

GENERAL NOTES

- Attachments, connections or fasteners of any nature are to properly and permanently be secured in conformance with best practice and the General Contractor is responsible for improving them accordingly. The drawings highlight special conditions only and by no means illustrate every connection. The Contractor is responsible for improving connection accordingly.
- General Contractor shall waive "Common Practice" and "Common Usage" as construction criteria wherever details and Contract Documents of governing codes, ordinances, etc. require quantity or better quality than common practice or common usage would require.
- The General Contractor shall submit shop drawings and submittals order and schedule delivery of materials in ample time to avoid delays in construction. If an item is found to be unavailable or to have a long lead time, the General Contractor shall notify Architect immediately with a proposed alternative.
- The General Contractor shall notify the Owner, the Landlord, and the Architect in writing of any deficiencies, errors, conflicts or omissions found in the construction documents and/or specifications prior to the commencement of the work in this area. Any unreported deficiencies will become the responsibility of the General Contractor to correct.
- The General Contractor shall exercise extreme care and precaution during the construction of the Work, and schedule work, to minimize disturbances to adjacent spaces and/or structures and their occupants, property, public thoroughfares, etc. The General Contractor shall take precautions and be responsible for the safety of all building occupants from construction procedures. The General Contractor shall be responsible for any overtime costs incurred thereby.
- All debris shall be removed from the site on a daily basis when possible. Upon completion of the work, remove all debris from the building created by the work provided under this Contract and leave all areas clean. Trash is not permitted to be burned on site.
- All abandoned miscellaneous nails, hangers, staples, wires, conduits and debris shall be removed from the walls and areas of exposed ceilings. Remove all abandoned pipe sleeves in floor slabs. Patch existing slab as req. to maintain UL fire rating of floor slab where pipes and conduits have been removed.
- Slab penetrations less than 2" around new and existing piping, conduit, ductwork, etc. shall be filled with acoustic foam and/or sealant to ensure acoustical separation between floor slabs. Slab penetrations greater than 2" around new and existing piping, conduit, ductwork, etc. shall be filled with concrete. All piping, conduit, ductwork, etc. shall be wrapped with expansion material prior to filling with concrete. Expansion material shall be approved by the MEP Engineer.
- Contractor shall provide the Team with a construction schedule showing the proposed phasing. Any long lead items that will affect the Substantial Completion date shall be brought to the Architect's attention immediately.
- Provide protection for existing finishes to remain, including restrooms, lobbies and corridors and repair damages as a result of construction. Document any existing conditions or damages prior to the start of construction
- General Contractor shall be responsible for providing exhaust for dryers, bathrooms, and ranges to exterior with proper terminus (not to be located on street side elevation). Verify terminus type and location with owner prior to installation.
- The Architect shall not be responsible for constructed variations from the information contained here-in unless reviewed and approved by Architect.
- Do not scale drawings, but rather inquire of Architect. Reproduction of these drawings is prohibited unless written permission is obtained from the Architect.
- All Trades to caulk with Manicapapality Approved "Fire Caulk" at all top plate penetrations.

WALL SECTION NOTES

- Bituminous Damp Proofing shall be applied to exterior foundations of all habitable spaces.
- All treated lumber shall bear the designation AWPA C22. Pressure treated lumber shall be used in the following locations:
 - Wood in contact with concrete or masonry;
 - Siding within 6" of the ground;
 - Wood exposed to weather.
- Install 5/8" Densglass sheathing behind all tub and shower walls, use water-resistant GWB for all bathroom ceilings U.O.

INTERIOR FINISH NOTES

- Refer to Finish Schedule and Finish Plan for extent and type. All wall surfaces, metal frames, and trim shall be painted, U.O. All surfaces to be painted shall be prepared for priming in accordance with the manufacturer's specifications.
- All painted surfaces shall receive 1 prime and 2 finish coats as follows:
 - GWB surfaces - Interior eggshell latex paint
 - GWB ceiling surfaces - Interior flat latex paint
 - Hollow Metal/Wood - Odorless interior semi-gloss alkyl latex
- Paint is to be applied by a roller or brush on all surfaces. Only the prime coat may be spray applied. Provide a 12"x12" GWB sample for each color for Owner's approval prior to the start of the Work.
- Toilet and bathing room floors shall have a smooth, hard, non-absorbant surface that extends upward onto the walls at least 6"
- Walls within 2" of urinals and waterclosets shall have a smooth, hard, non-absorbant surface to the height of 4' above the finish floor. Verify material with room schedule and/or Architect

MILLWORK NOTES

- Millwork shall be fabricated and installed by a qualified woodworker with experience in commercial applications of the scope of the job. The General Contractor shall submit shop drawings and hardware catalogue cuts of all millwork and hardware for review by Architect and in accordance with the Construction Documents. Shop drawings shall show the design and the dimensions and clearly indicate at a large scale to the Architect the method and means of construction. Fabrication of millwork shall not proceed until shop drawings have been reviewed by the Architect. Shop drawings shall be submitted with 3 sets of prints. Cabinet designer/ installer shall field measure area of work after installation of gypsum wallboard for proper fitting.
- The method of manufacturing, fabricating and installing millwork, equipment, and its structural components defined in the contract documents is representative and indicates design intent only. If the materials, details or dimensioned properties are at variance with the General Contractor's or manufacturer's recommendations, alternate details will be considered for review by the Architect. It is the responsibility of the General contractor to guarantee that the millwork and equipment will have proper support, stability and fault-free performance and provide all necessary blocking. All work shall conform to American Woodworking Institute (AWI) standards for premium grade construction.
- All cabinets shall be of flush overlay construction with 4" satin chrome wire pulls U.O. Interior surfaces of cabinets not exposed to view shall be melamine with plastic laminate edgbanding to match melamine. All cabinet exterior surfaces exposed to view shall be plastic laminate. All open cabinet shelving shall be plastic laminate with plastic laminate edgbanding to match. All counter supports shall be plastic laminate. All counters used as work surfaces and all paneling shall be balanced and have phenolic backer laminated to entire underside or back face. Cabinet doors shall have plastic laminate on all faces and edges. All casework shall comply with AWI Section 400 for premium grade construction.
- Millwork covered with plastic laminate shall be fabricated and assembled by skilled workmen to the satisfaction of the Architect. Exposed surfaces shall be free from dents, tool marks, warpage, buckling, or open joints. All joints, corners and mitered connections shall be made tightly so the edges are entirely concealed. It is the responsibility of the General Contractor to obtain accurate field measurements and to verify dimensions and to provide shop drawings to ensure an accurate fit.
- Only exposed hardware is specified in this document. The Contractor is to supply all other necessary hardware to complete the Work. All unspecified hardware shall be of the highest quality commercial grade heavy duty. The Contractor is to provide catalog cuts of all hardware for review by Architect. Provide plastic grommets at cabinetry and counters for wire management as noted in the drawings. Submit catalog and samples to Architect for approval.
- Install millwork to be plumb, level, true and straight with no distortions. Shim as required using concealed shims. Provide all required blocking at new or existing construction for installation of millwork. Scribe and cut millwork to fit adjoining work. Provide sealant to match adjacent surfaces at all gaps. All exposed anchors, nail heads, screw heads, chips, indentations or imperfection in the wood surface to be painted shall be filled, sanded, sealed and prepared for painting. All lumber, particle board, finish wood, plywood, blocking, etc. shall be fire retardant treated (FRT) where required by local building codes, as interpreted by the local Code Official. No exposed fasteners.
- The General Contractor shall be responsible for making certain that the millwork items are not delivered until areas are sufficiently dry so that the millwork will not be damaged by excessive changes in moisture content. All delivered units shall match the final approved shop drawings and samples. Units which are marred, chipped or otherwise damaged shall be repaired or replaced as determined by the Architect. Units shall be protected during shipment and installation. After installation of units in their proper location and substantial completion of the Work, all protection shall be removed and all surfaces thoroughly cleaned to the complete satisfaction of the Architect. Surfaces shall then be covered and protected.
- Wood cabinets, countertops, trim and rails are to comply with AWI Section 400 and other applicable American Woodworking Institute Standards (AWI) for custom grade.
- Install millwork in compliance with AWI Section 1700, Premium Grade unless otherwise indicated. Flush wood paneling shall conform to AWI Section 500, Premium. Wood veneer to have "AA" face with 3/4" MDF core. See drawings for species and cut. Veneer shall be book matched, balance match panel faces and sequence between adjacent panels. Exposed edges to be veneered same species and finish as face. Provide sound back of similar species.
- To the greatest extent possible, furnish millwork with shop applied finishes. Defer only final touch-up, cleaning, and polishing until after installation. Shop applied finishes shall comply with AWI 1500, Premium Grade, 1R-2 catalyzed lacquer, semi-filled.

FLOOR FINISH NOTES

- Refer to Finish Plan & Schedule for extent and type of all floor finishes.
- GC to flashpatch floor to provide a level surface that shall not exceed 1/4" over 10 feet cumulative. At floor finish transitions fish patch to smooth transition of finished material to maintain level finished floor surface.
- All floors to slope to floor drains - 1/4" per 1'-0" U.N.O
- All exterior floor slabs to receive a light broom concrete finish. U.N.O.
- SEE STRUCTURAL DRAWINGS FOR ALL FOUNDATION SPECIFICATIONS.

TILE NOTES

- Tile shall be installed by a qualified installer with experience in commercial applications. The General Contractor shall submit dimensioned shop drawings showing layout and 3 samples of each type and color of tile and grout selected for review by Architect and in accordance with the Construction Documents. Mount tiles on plywood backing and grout to demonstrate tile patterns.
- It is the responsibility of the General Contractor to obtain accurate field measurements and to verify dimensions. Any dimensions or field conditions which vary from the design intent of the drawings shall be brought to the attention of the Architect by the General Contractor for review prior to proceeding with work. It is the responsibility of the General contractor to provide all necessary blocking.
- Tile shall be manufactured in compliance with Standard Grade Requirements of ANSI A137.1. Installation of tile shall be in compliance with requirements set forth in Handbook for Ceramic Tile Installation produced by the Tile Council of America. Provide all necessary caps, stops, returns, trimmers, and other shapes to complete installation (color and finish to match adjacent tile). Provide a quantity equal to 2% of each type and color of tile from same production run as installed material for attic stock.
 - Floors: Thin set, TCA F122
 - Walls: Organic adhesive, TCA W242
 - Expansion Joints: TCA EJ171
 - Epoxy Adhesive: TCA F116
- Ceramic Tile: ANSI A137.1
 Selections: Refer to Schedule of Finishes
 Floor Tiles: Unglazed, Wall Tile: Glazed
 Trim Tiles: Finish type, size, and color, to match field.
 Wainscot Cap: Bullnose
 Base: Cove bottom/Straight top with matching wall tile above
 Inside Corners: Square, Outside Corners: Bullnose
 Jamb: Bullnose where tiles project from jamb.
- For tile exhibiting color variations, blend tile in factory and package accordingly so that tile units taken from one package show the same range in colors as those taken from other packages and match approved samples. Where factory-mounted tile is required, provide back-face or edge-mounted tile assemblies as standard with manufacturer unless another mounting method is indicated.
- Natural Stone Tile Marble to meet requirements of ASTM C503 Granite; ASTM C615. Abrasive Resistance: ASTM C241; 12 Ha minimum. Marble Threshold, ASTM C503 to be White Georgia, Imperial Black or Antique Silver and Honed. Refer to Schedule of Finishes for size, finish and thickness.
- Thin Set Mortar: ANSI A118.1, Commercially prepared dry mixture of Portland cement, inert fillers, and chemical additive. Do not use water-based adhesive setting methods with green-colored stone. General Contractor to obtain setting instructions from supplier. Organic Adhesive: ANSI A136.1; Type 1, High performance, multi-purpose floor and wall adhesive. Epoxy Adhesive: factory prepared, 100% epoxy resin and hardener with sand or mineral filler material to complying with ANSI A118.3 for thin-set applications for chemical resistant, water cleanable quarry tile installations. Grout: Latex portland cement; ANSI A118.6, Commercially prepared dry mixture of portland cement, sand, mineral fillers, and chemical additives. Color: Refer to Schedule of Finishes
- Mix materials and prepare surface in accordance with manufacturer's recommendations. Grind or fill concrete substrates as needed to comply with TCA allowable variations. Areas scheduled to receive tile flooring shall receive membrane application. Crack Isolation Membrane to be one-part elastomeric seamless membrane, 30 mil (cured thickness), and no water permeability as manufactured by Custom or Mapei.
- Comply with manufacturer's instructions for installation of each material needed as well as ANSI and TCA requirements. Extend tile work into recesses and under or behind equipment and fixtures, to form a complete covering without interruptions, except as otherwise shown. Terminate work neatly at obstructions, edges and corners without disrupting pattern or joint alignments. Layout tile work and center tile fields in both directions in each space or on each wall area. Avoid tile joints one half size. Align joints when adjoining tiles on floor, base, walls and trim that are the same size. Provide uniform joint width at ceramic tile to be not less than 1/16" or greater than 1/8". Natural Stone Tile to be butt jointed. Where stone tile abuts dissimilar flooring materials, provide terrazzo divider strips or other similar metal angle device to help prevent edge chipping caused by impact. Terrazzo Divider Strip or Schluter Trims #E100.
- Thin Set Application shall be per ANSI A108.5. Organic Adhesive Application shall be per ANSI A108.4. Use Latex portland cement grout conforming to ANSI A108.10. Tile shall be firmly set before grouting, allow a minimum of 48 hours. Remove mortar or adhesive from face and edges of tile.
- Provide expansion joints as follows: Natural Stone Tile same as grout joint; but not less than 1/4". Ceramic Tile not less than 1/8". Install expansion joints at 24' max. in each direction, where tile work abuts restraining surfaces such as perimeter walls, dissimilar floors, curbs, columns, and pipes, where changes occur in backing materials, at expansion, control, construction, cold and seismic joints in structure. Expansion joints shall be constructed during installation of tile. Do not cut joints after tile installation.
- Use clean water in initial cleaning. Remove surface laitance with a dry polishing cloth. Do not use acid in final cleaning of tile. Provide a non-yellowing, penetrating sealer on floor ceramic tile which does not leave a film or visible coating. Keep floor areas free from general traffic for at least 72 hours following installation. Protect walls from impact, vibrations and heavy hammering on adjacent and opposite walls.

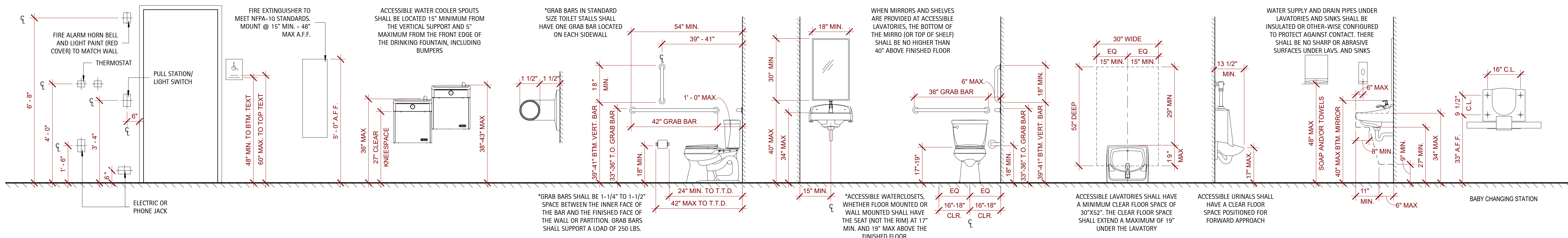

TYPICAL MOUNTING HEIGHTS

*PROVIDE REQ'D BLOCKING FOR GRAB BARS, WALL HUNG TOILETS, AND ACCESSORIES DURING FRAMING

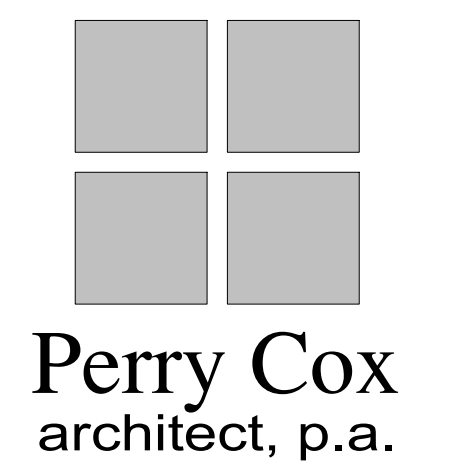
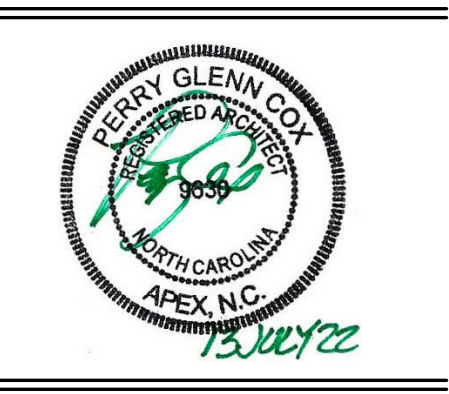

124 Salem Towne Court, Apex, NC 27502
 P. 919.363.5411
 www.pcoxdesign.com

NO.	REVISION	DATE

SHEET DISCRPTION
General Notes

PROJECT #: 2022002
 DATE ISSUED: 07/20/2022
 DRAWING BY: JGM/BSJ
 CHECKED BY: PGC/DSC

**WOODGROVE
 DR HORTON
 BATHHOUSE & POOL
 HARNETT COUNTY, NC**





D. CLUGSTON

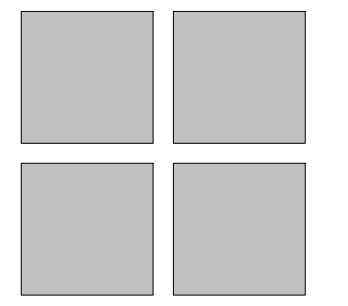

Perry Cox architect, p.a.
124 Salem Towne Court, Apex, NC 27502
P. 919.363.5411
www.pcoxdesign.com

DATE	
REVISION	
NO.	

SHEET DESCRIPTION
First Floor Plan

PROJECT #: 2022002
 DATE ISSUED: 07/20/2022
 DRAWING BY: JGM/BSJ
 CHECKED BY: PGC/DSC

WOODGROVE
 DR HORTON
 BATHHOUSE & POOL
 HARNETT COUNTY, NC

A1.1

TOILET ACCESSORIES			
MARK	ITEM	MANUFACTURER	MODEL NUMBER
TTD	SURFACE MOUNTED DUAL ROLL TOILET TISSUE HOLDER	AMERICAN SPECIALTIES, INC	0715
GB	GRAB BAR - 1 1/2" DIA., S/S, PREENED GRIP, SNAP FLANGE 3/8", 42" & 18"	AMERICAN SPECIALTIES, INC	3800 TYPE-01
MIR	INTERLOK S.S. FRAMED MIRROR W/ SHATTER RESISTANT GLASS	AMERICAN SPECIALTIES, INC	0600
CH	SURFACE MOUNTED COAT HOOK	AMERICAN SPECIALTIES, INC	0714
PTD	SURFACE MOUNTED PAPER TOWEL DISPENSER	AMERICAN SPECIALTIES, INC	0210
SD	SURFACE MOUNTED S.S. AUTOMATIC LIQUID/GEL SOAP DISPENSER	AMERICAN SPECIALTIES, INC	0360
SN	SURFACE MOUNTED SANITARY NAPKIN DISPOSAL (WOMEN'S TOILET ONLY)	AMERICAN SPECIALTIES, INC	0852
MH	MOP HOLDER	AMERICAN SPECIALTIES, INC	0796
CS	SURFACE MOUNTED BABY CHANGING STATION	AMERICAN SPECIALTIES, INC	9012
TP	TOILET PARTITION - FLOOR SUPPORTED W/ HEADRAIL, POWDER COATED STEEL FINISH	GENERAL PARTITIONS	SERIES 40-5

NOTE SEE SHEET GO.4 FOR TYPICAL MOUNTING HEIGHTS & CLEARANCES

WALL TYPE DETAILS

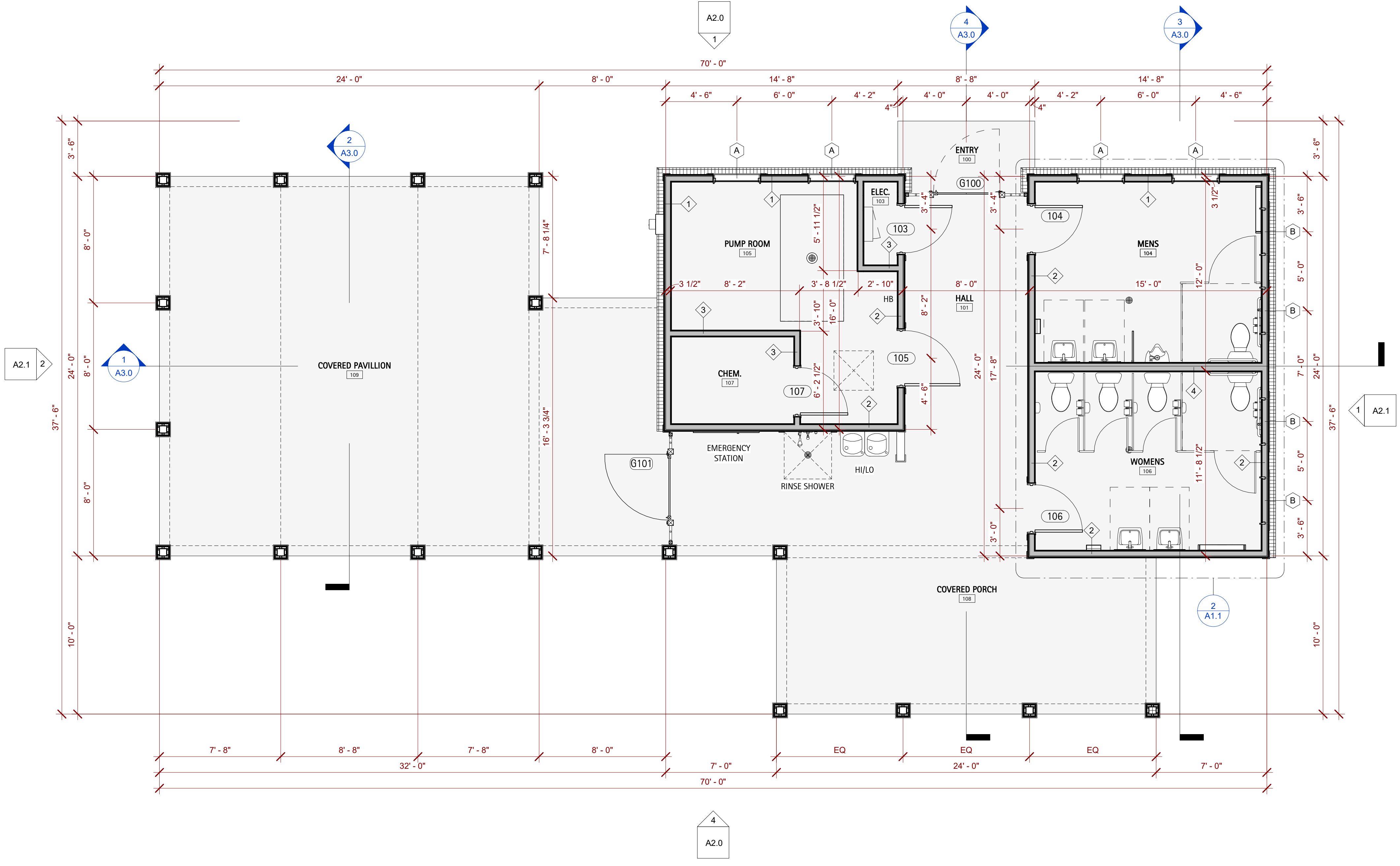
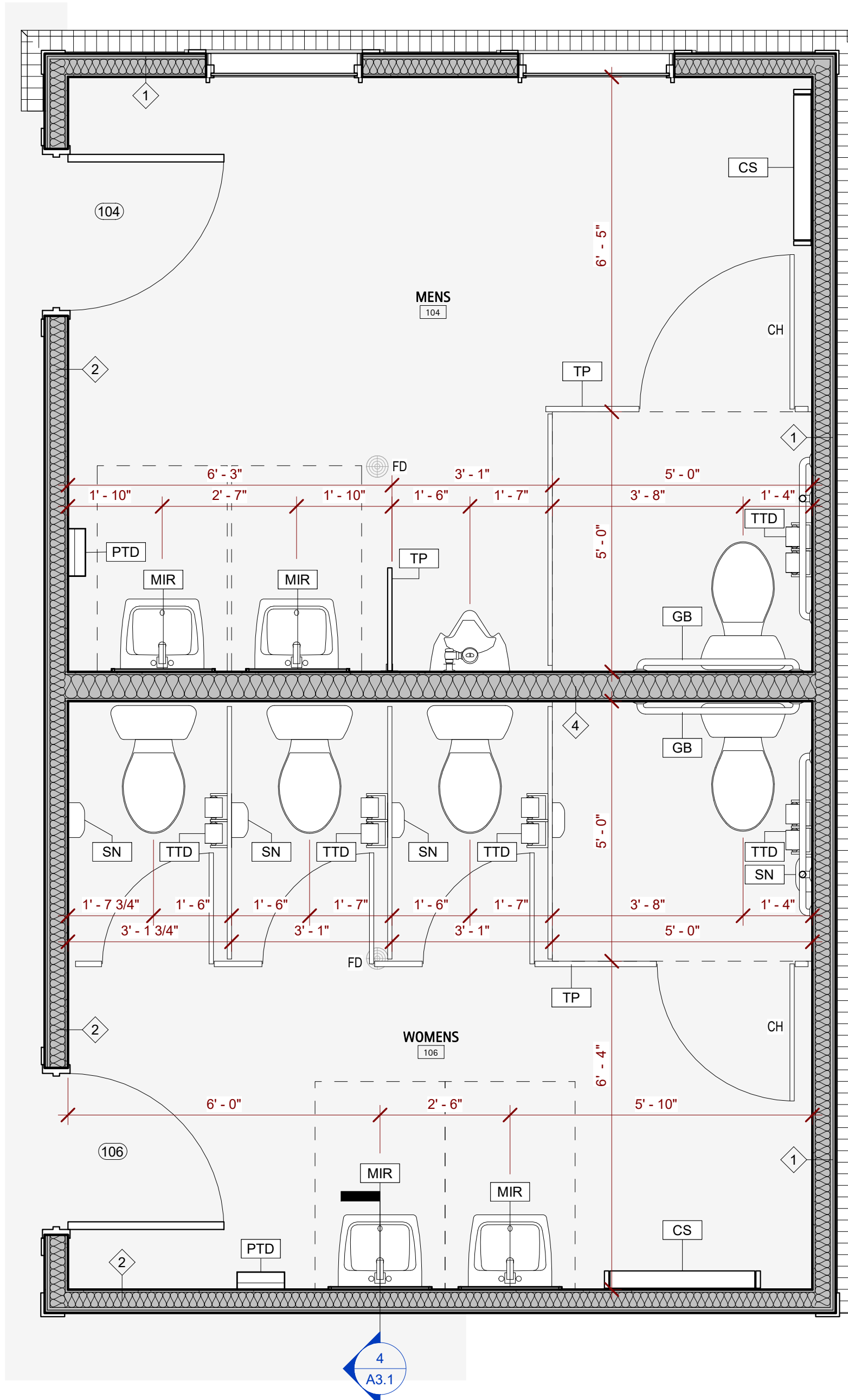
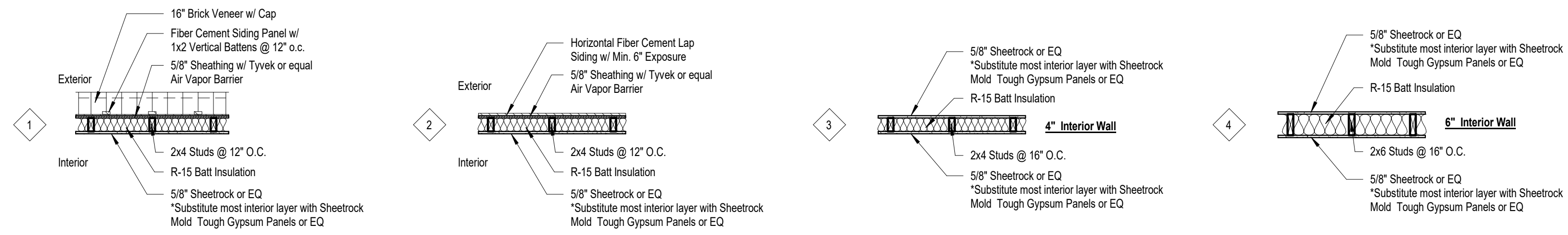



D. CLUGSTON

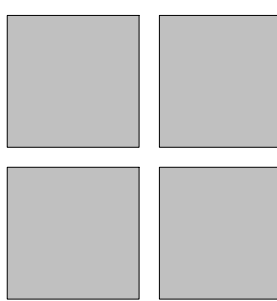

Perry Cox architect, p.a.

124 Salem Towne Court, Apex, NC 27502
P. 919.363.5411
www.pcoxdesign.com

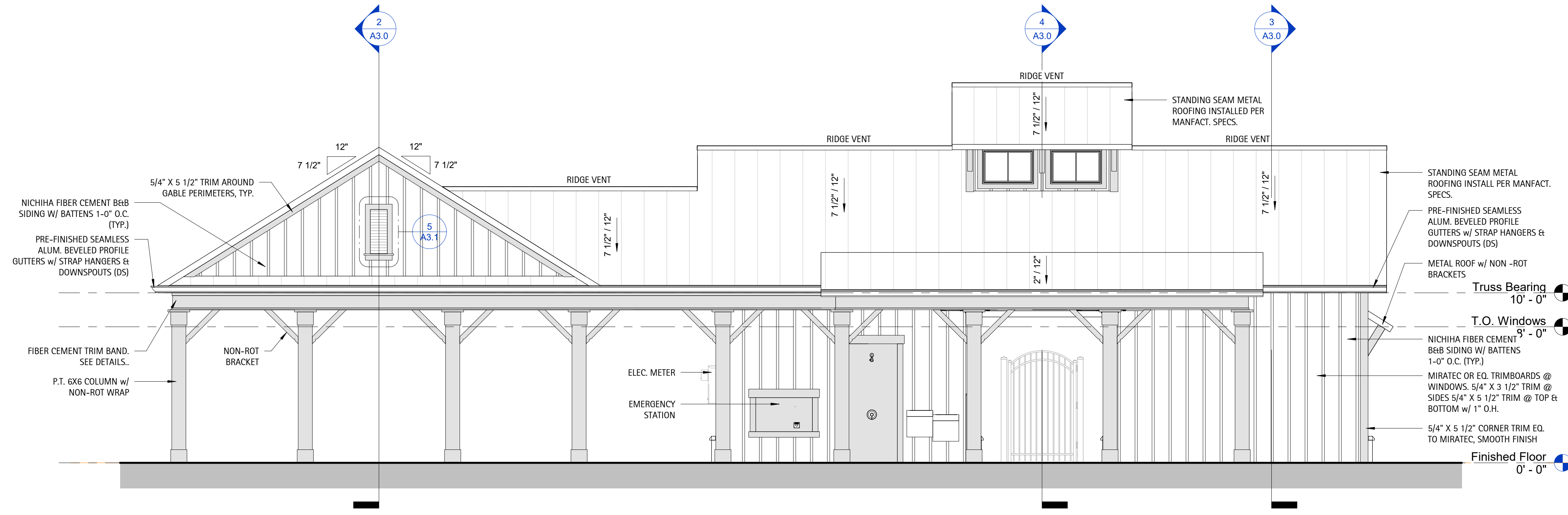

Elevation - Rear
1/4" = 1'-0"

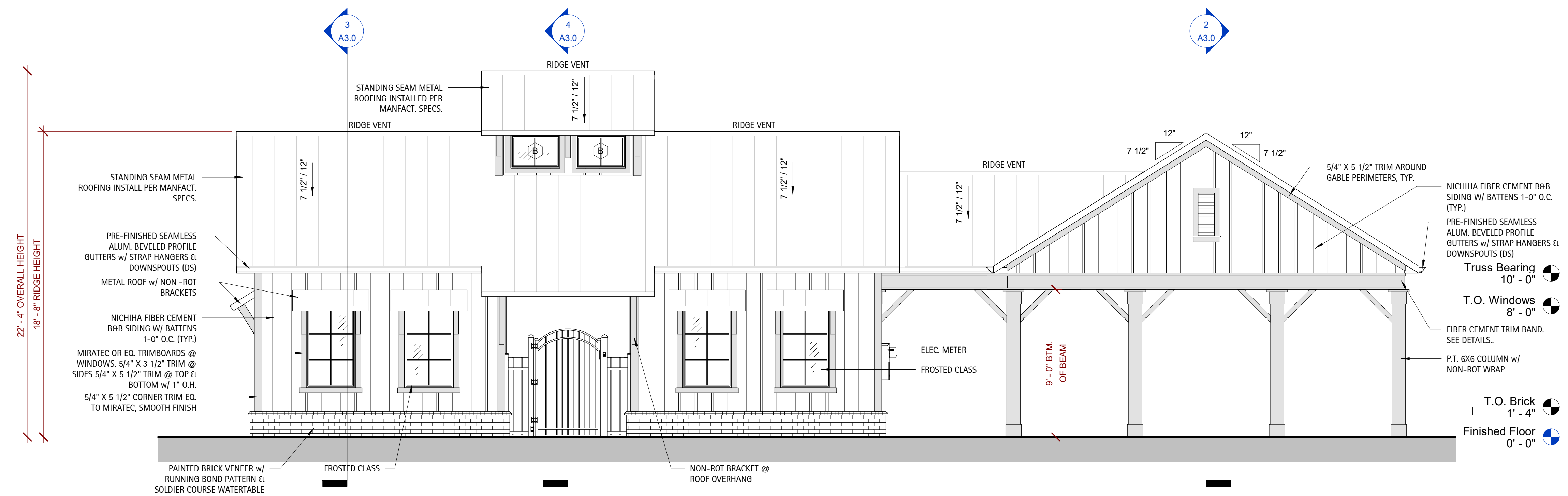

Elevation - Front
1/4" = 1'-0"

NO.	REVISION	DATE

SHEET DISCUSSION	
Exterior Elevations	
PROJECT #:	2022002
DATE ISSUED:	07/20/2022
DRAWING BY:	JGM/BSJ
CHECKED BY:	PGC/DSC

**WOODGROVE
DR HORTON
BATHHOUSE & POOL
HARNETT COUNTY, NC**

A2.0

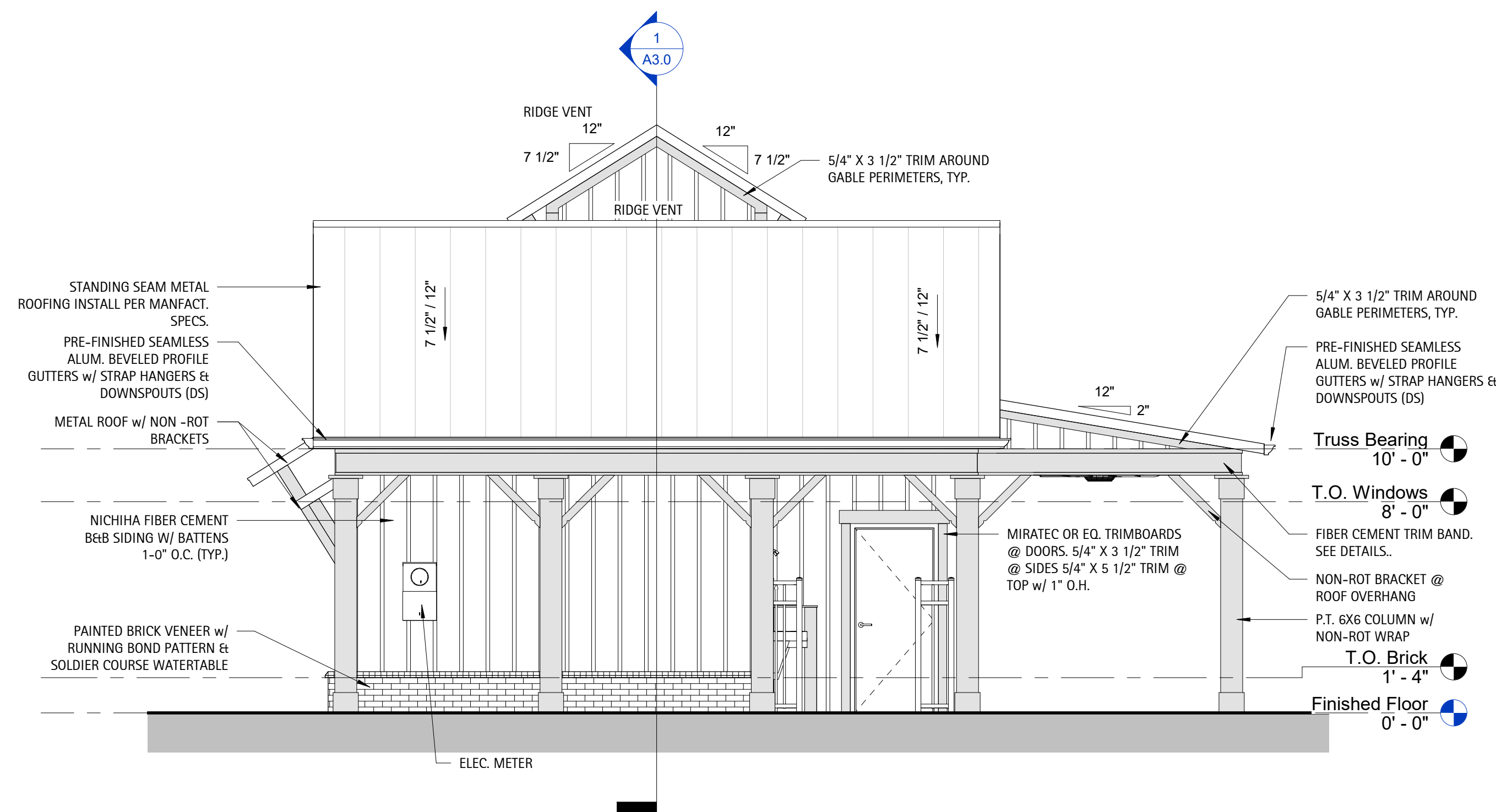

Elevation - Left
1/4" = 1'-0"

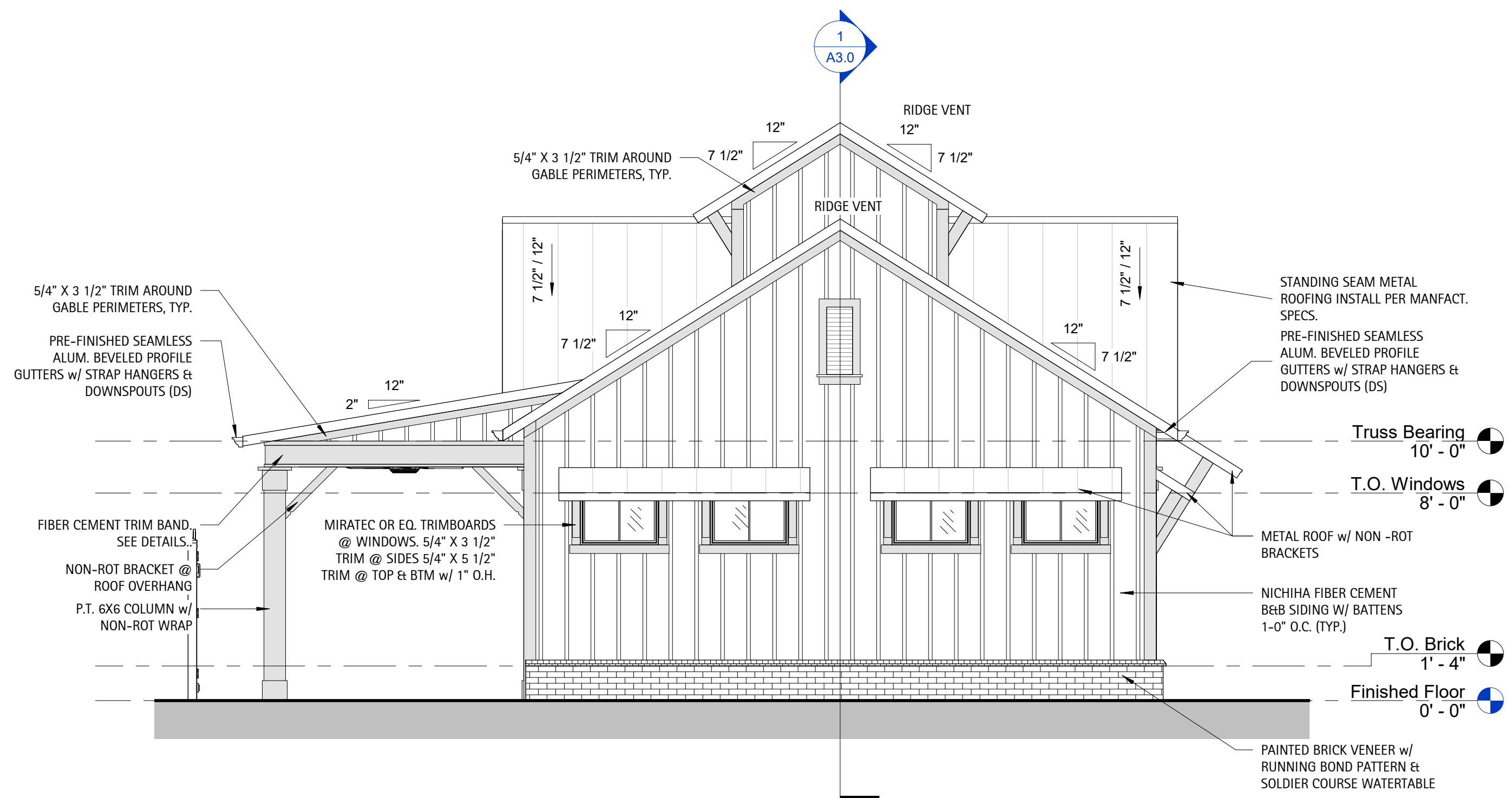

Elevation - Right
1/4" = 1'-0"



D. CLUGSTON

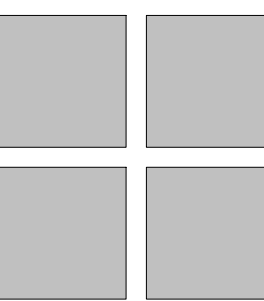

Perry Cox
architect, p.a.

124 Salem Towne Court, Apex, NC 27502
P. 919.363.5411
www.pcoxdesign.com

DATE
REVISION
NO.

SHEET DISCRPTION

Exterior Elevations

PROJECT #: 2022002
DATE ISSUED: 07/20/2022
DRAWING BY: JGM/BSJ
CHECKED BY: PGC/DSC

**WOODGROVE
DR HORTON
BATHHOUSE & POOL
HARNETT COUNTY, NC**

A2.1



D. CLUGSTON

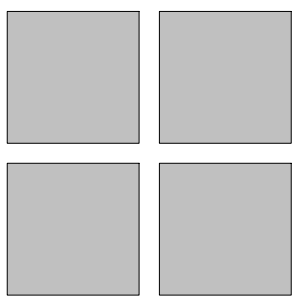

Perry Cox architect, p.a.
124 Salem Towne Court, Apex, NC 27502
P. 919.363.5411
www.pcoxdesign.com

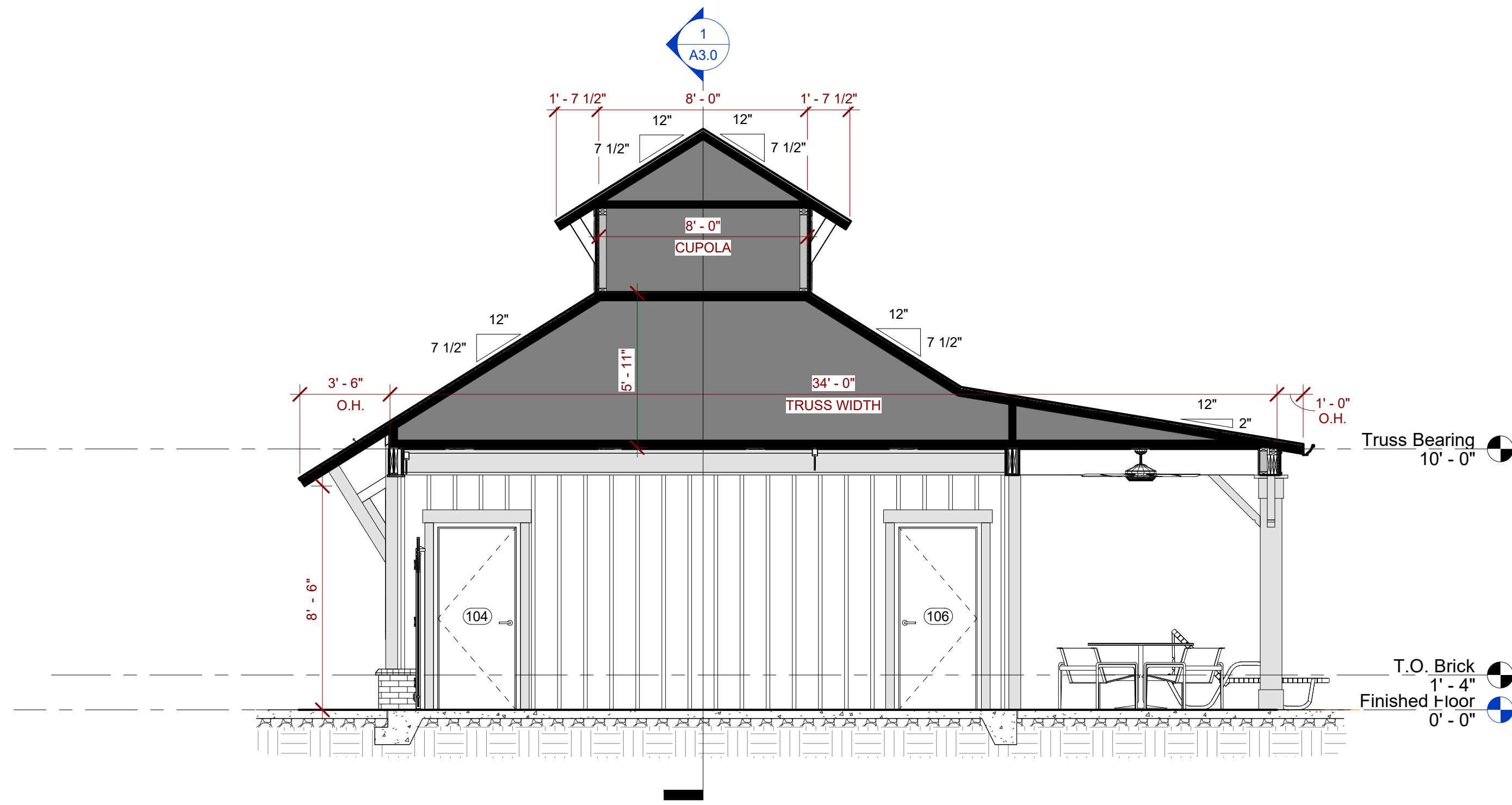

4 Section - Through Hallway
1/4" = 1'-0"

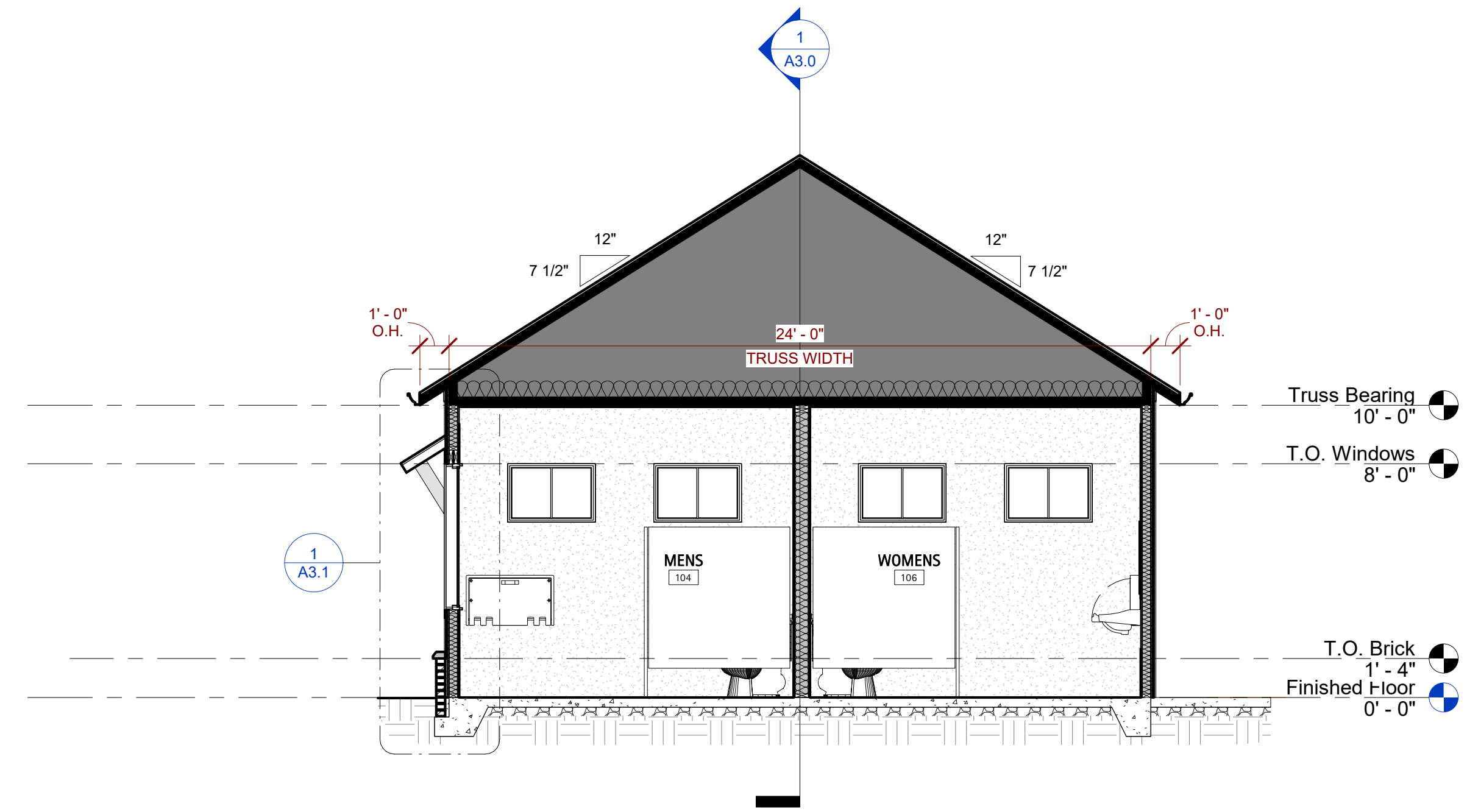

3 Section - Through Restrooms
1/4" = 1'-0"

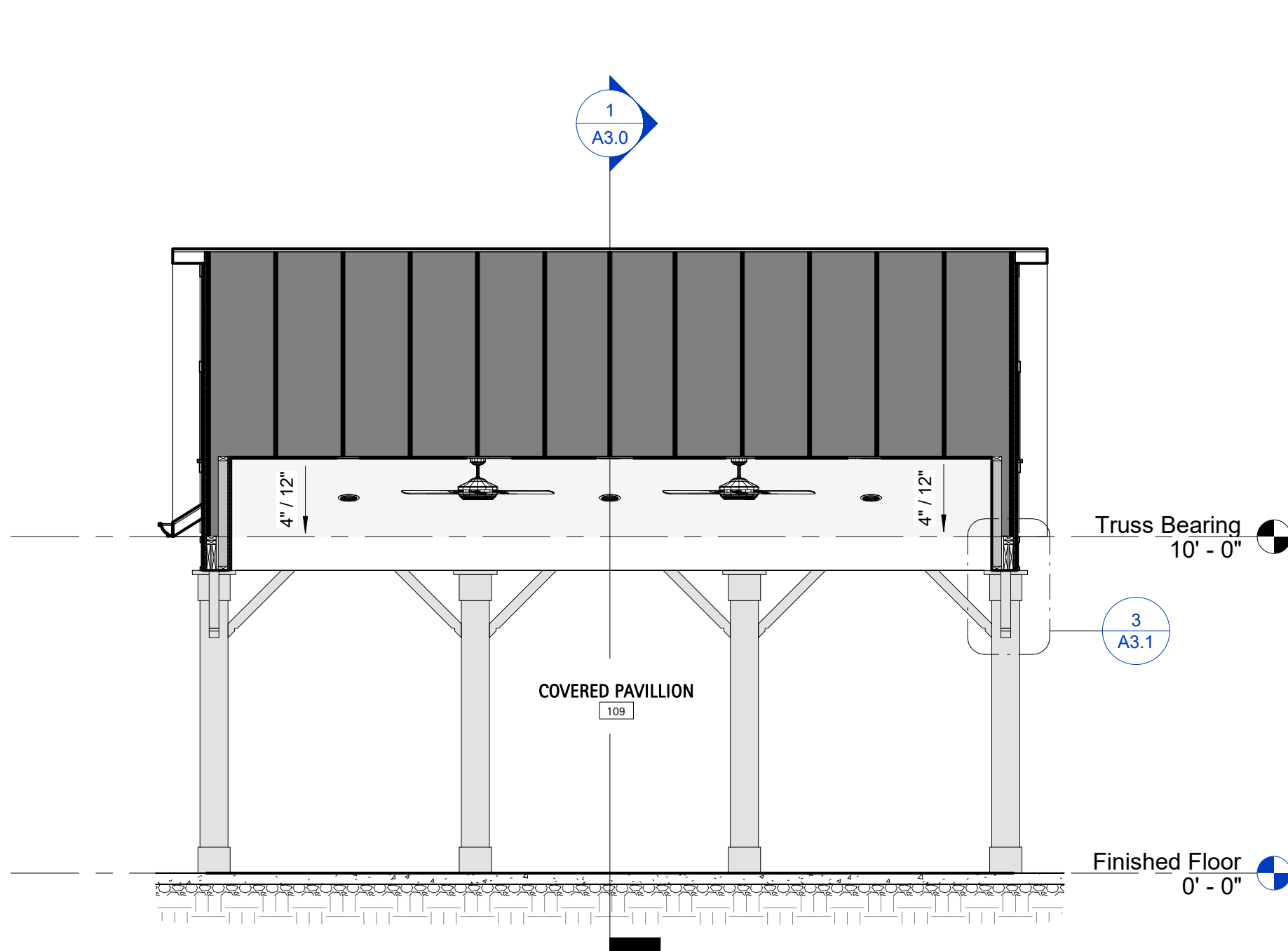

2 Section - Through Porch Ridge
1/4" = 1'-0"

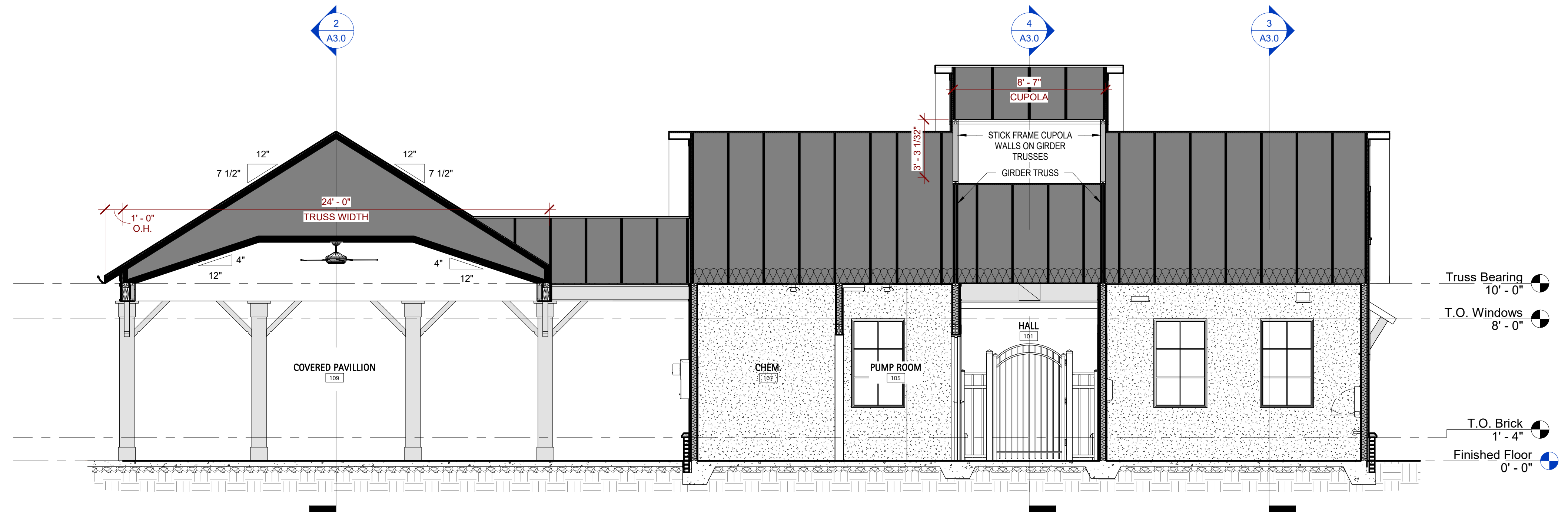

1 Section - Through Main Ridge
1/4" = 1'-0"

DATE
REVISION
NO.

SHEET DISCRPTION
Building Sections

PROJECT #:	2022002
DATE ISSUED:	07/20/2022
DRAWING BY:	JGM/BSJ
CHECKED BY:	PGC/DSC

WOODGROVE
DR HORTON
BATHHOUSE & POOL
HARNETT COUNTY, NC

A3.0



D. CLUGSTON

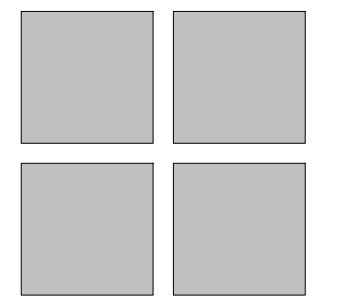

Perry Cox architect, p.a.

124 Salem Towne Court, Apex, NC 27502
P. 919.363.5411
www.pcoxdesign.com

DATE	
REVISION	
NO.	

SHEET DISCUSSION
Wall Sections & Details

PROJECT #: 2022002
DATE ISSUED: 07/20/2022
DRAWING BY: JGM/BSJ
CHECKED BY: PGC/JSC

WOODGROVE
DR HORTON
BATHHOUSE & POOL
HARNETT COUNTY, NC

A3.1

Full Brick Veneer at Bottom of Wood Backup Wall Cavities With Less Than 2" of Remaining Airspace Sure Cavity™ (SC 5016 or SC 5032) and Cavity Weep™ (CV 5010)

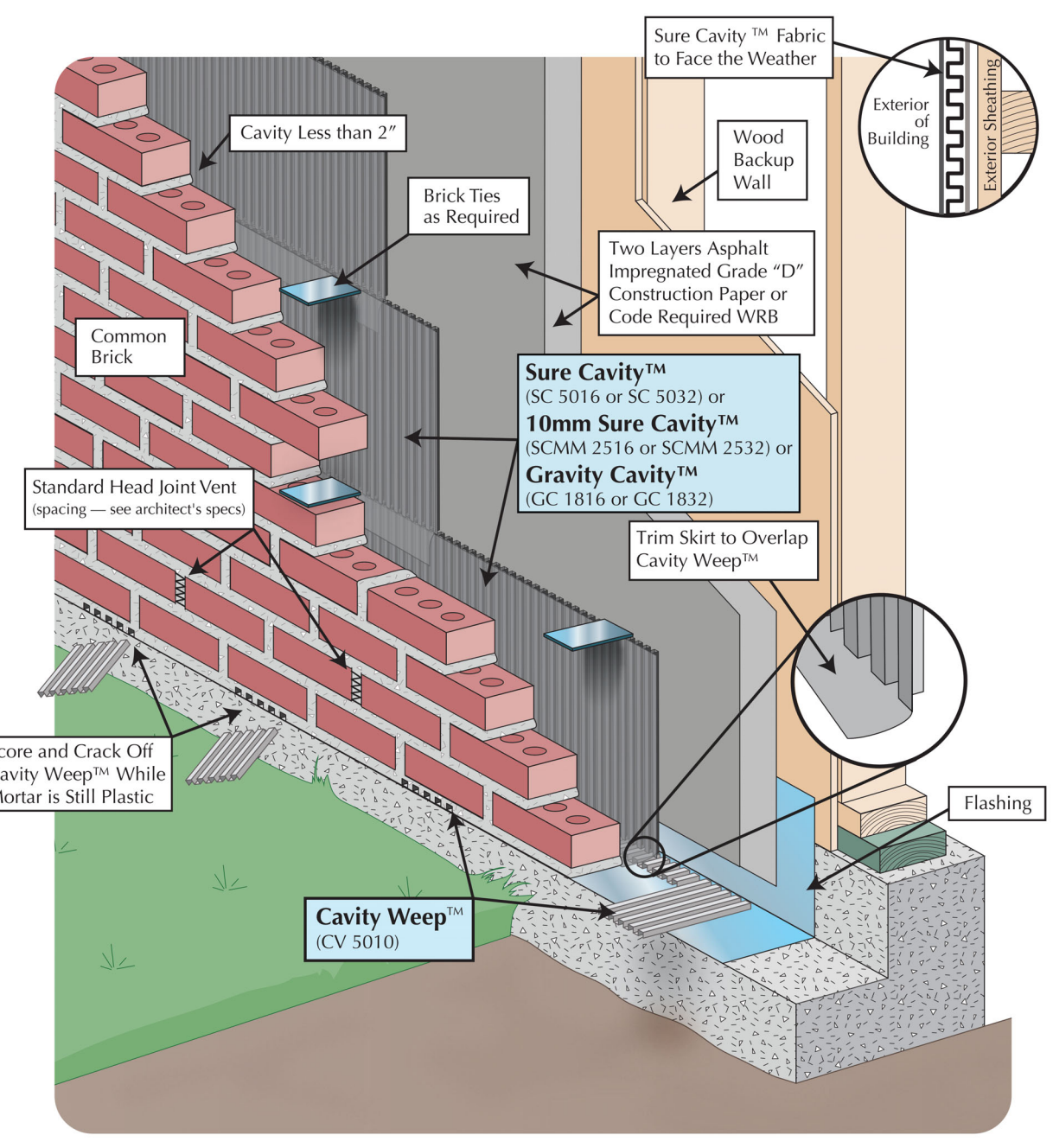

05FB02WD001
Copyright © 2012 Masonry Technology Incorporated, All Rights Reserved.
MTI details are created from sources deemed to be reliable. However, MTI does not guarantee the accuracy or completeness of any information, nor shall be held responsible for any errors, omissions, or damages arising out of the use of this information. These details are created with the understanding that MTI is providing information but is not attempting to render engineering or other professional services. If such services are required, the assistance of an appropriate profession should be sought. Use MTI materials in strict conformance with local building codes and regulations. Consult local code/code officials prior to installation. It is the buyer's responsibility to ensure that MTI materials are used in strict conformance with local building codes and regulations.

Head Joint Weeps Steel Lintel Installation with Wood Backup Wall

Sure Cavity™ (SC 5016 or SC 5032) or 10mm Sure Cavity™ (SCMM 2516 or SCMM 2532) or Gravity Cavity™ (GC 1816 or GC 1832) and Head Joint Weeps™ (HJW 3845) and Moisture Diverter™ (DS 2858)

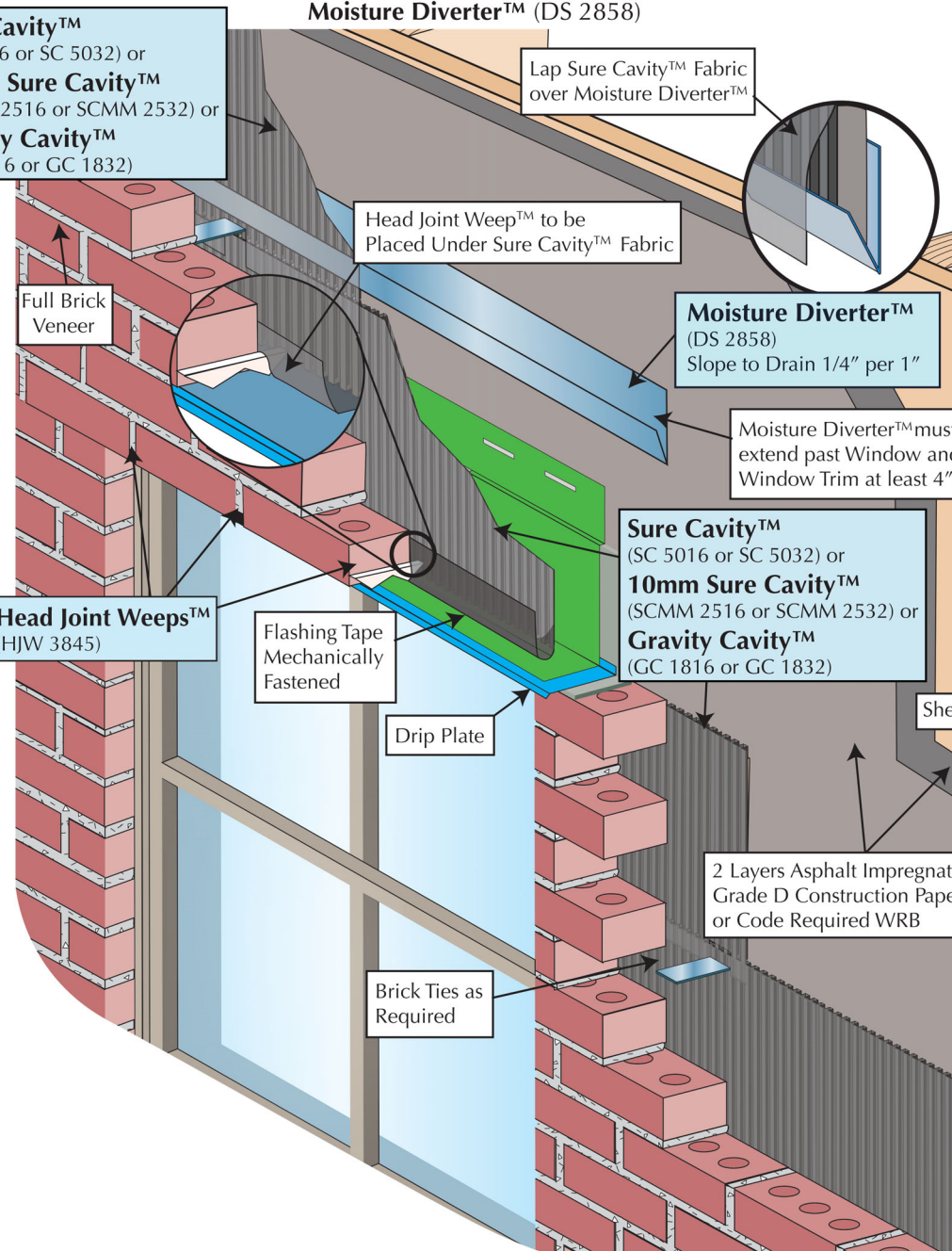

05FB03WD002
Copyright © Masonry Technology Incorporated, 4/2010, All Rights Reserved.
MTI details are created from sources deemed to be reliable. However, MTI does not guarantee the accuracy or completeness of any information, nor shall be held responsible for any errors, omissions, or damages arising out of the use of this information. These details are created with the understanding that MTI is providing information but is not attempting to render engineering or other professional services. If such services are required, the assistance of an appropriate profession should be sought. Use MTI materials in strict conformance with local building codes and regulations. Consult local code/code officials prior to installation. It is the buyer's responsibility to ensure that MTI materials are used in strict conformance with local building codes and regulations.

Brick Veneer at Bottom and Side of Window

Sure Cavity™ (SC 5016 or SC 5032) or 10mm Sure Cavity™ (SCMM 2516 or SCMM 2532) or Gravity Cavity™ (GC 1816 or GC 1832) and Wall Opening Weeps™ (WOW 9095)

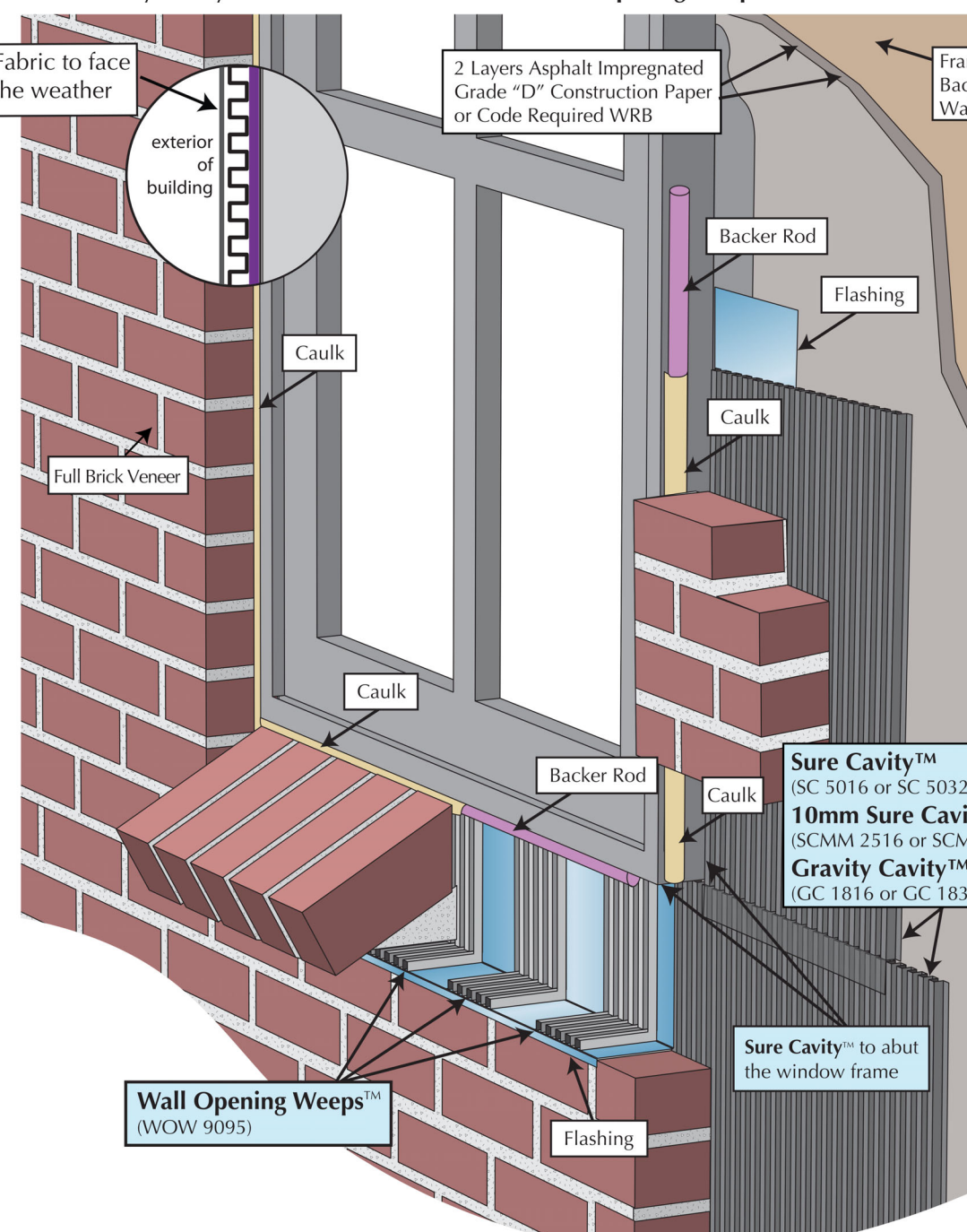

05FB03WD001
Copyright © Masonry Technology Incorporated, 2/2009, All Rights Reserved.
MTI details are created from sources deemed to be reliable. However, MTI does not guarantee the accuracy or completeness of any information, nor shall be held responsible for any errors, omissions, or damages arising out of the use of this information. These details are created with the understanding that MTI is providing information but is not attempting to render engineering or other professional services. If such services are required, the assistance of an appropriate profession should be sought. Use MTI materials in strict conformance with local building codes and regulations. Consult local code/code officials prior to installation. It is the buyer's responsibility to ensure that MTI materials are used in strict conformance with local building codes and regulations.

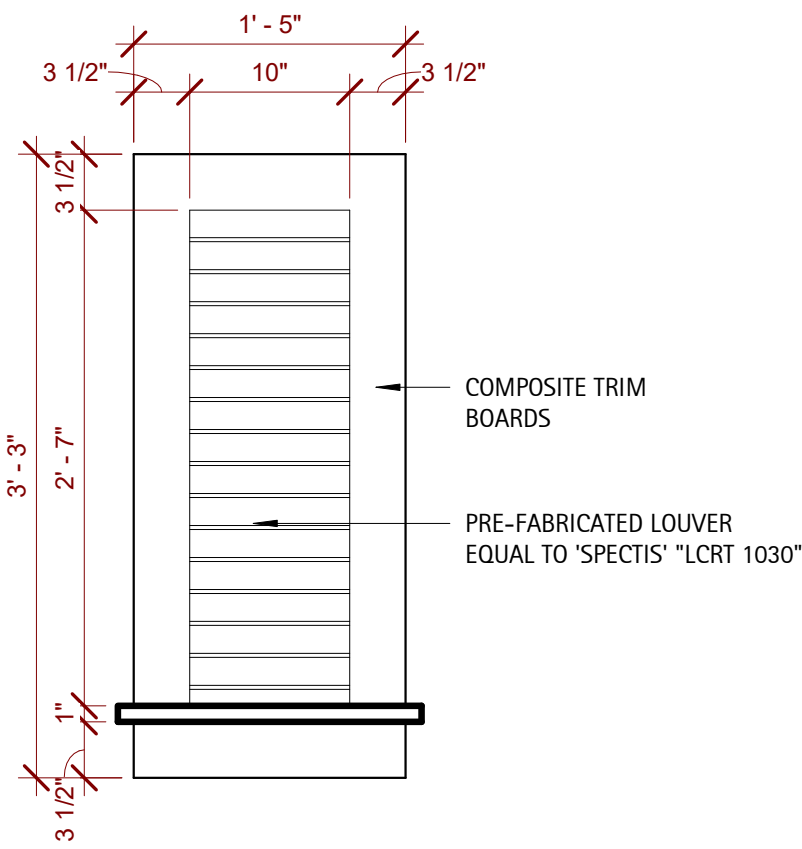

5
A3.1
Detail - Gable Vents
1" = 1'-0"

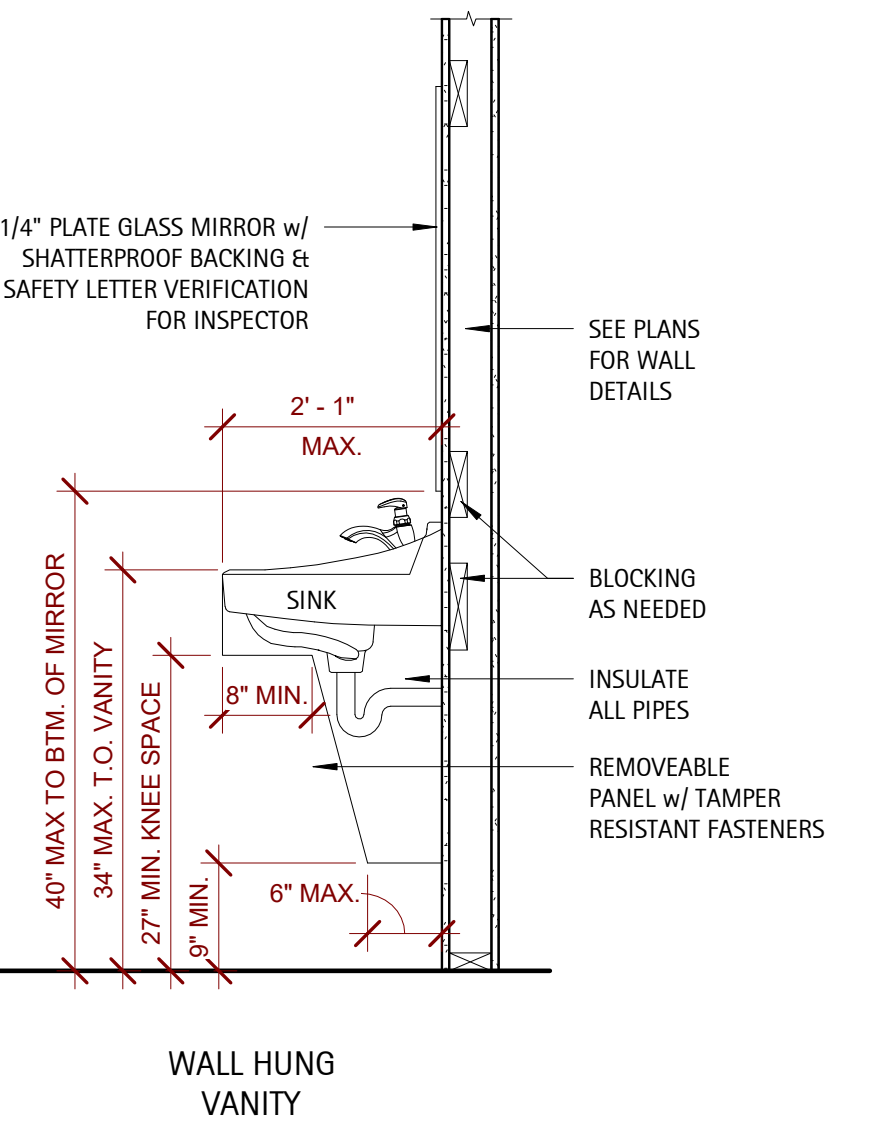

4
A3.1
Detail - Typical Sink Sections
3/4" = 1'-0"

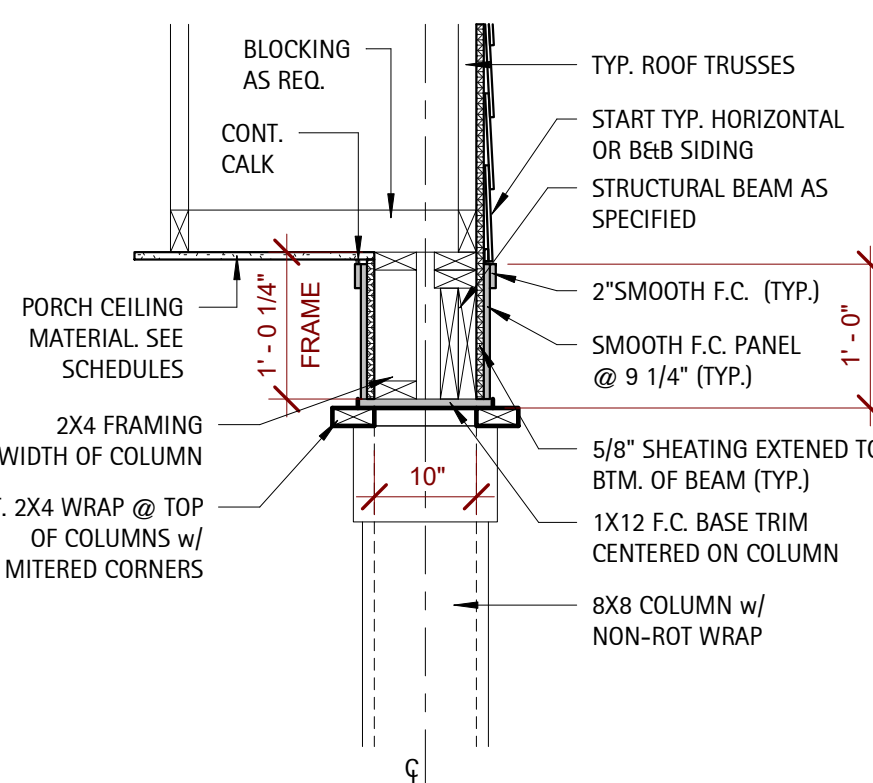

3
A3.1
Detail - Typical Trim Band
3/4" = 1'-0"

2 A3.1 Detail - Brick on Wood 12" = 1'-0"

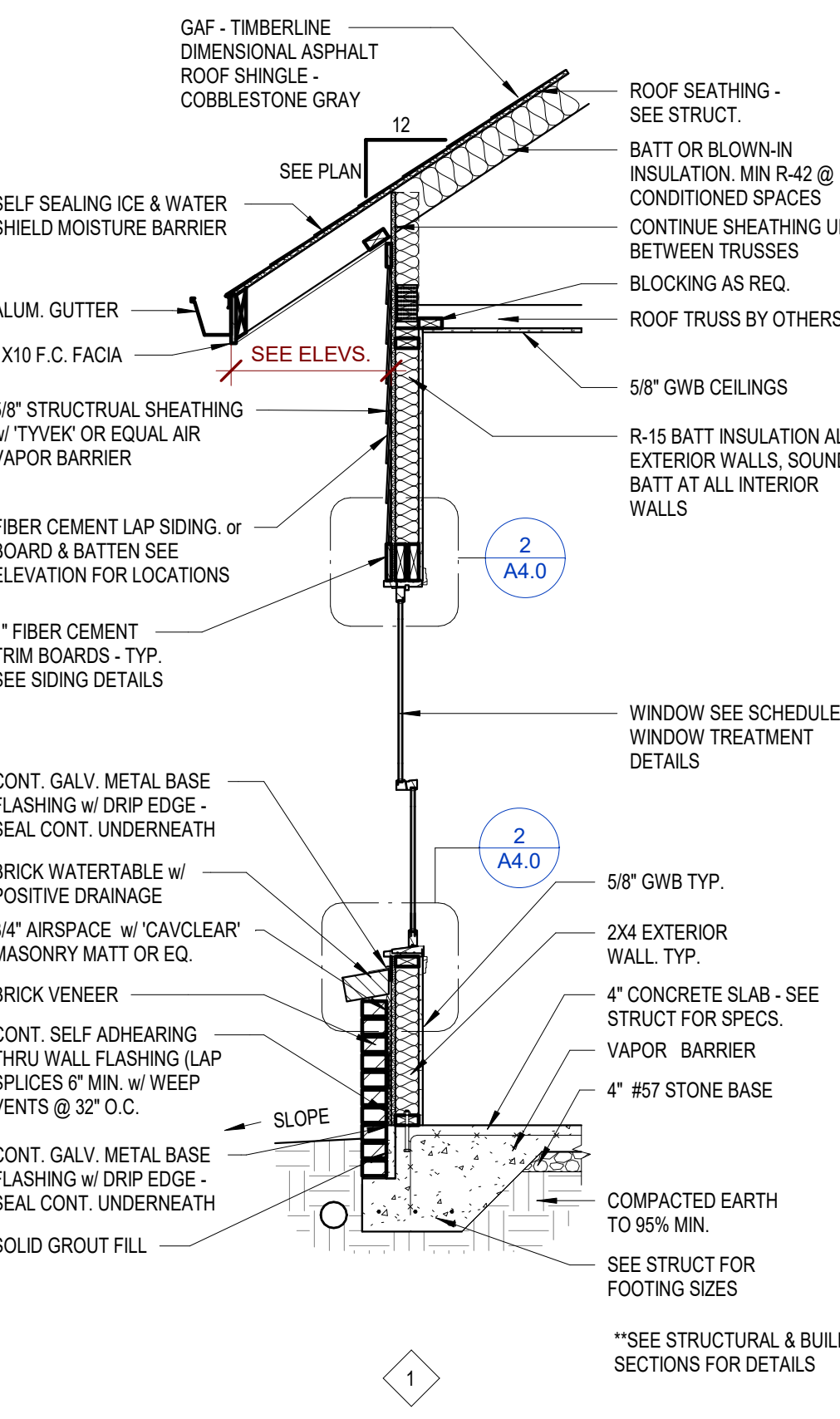
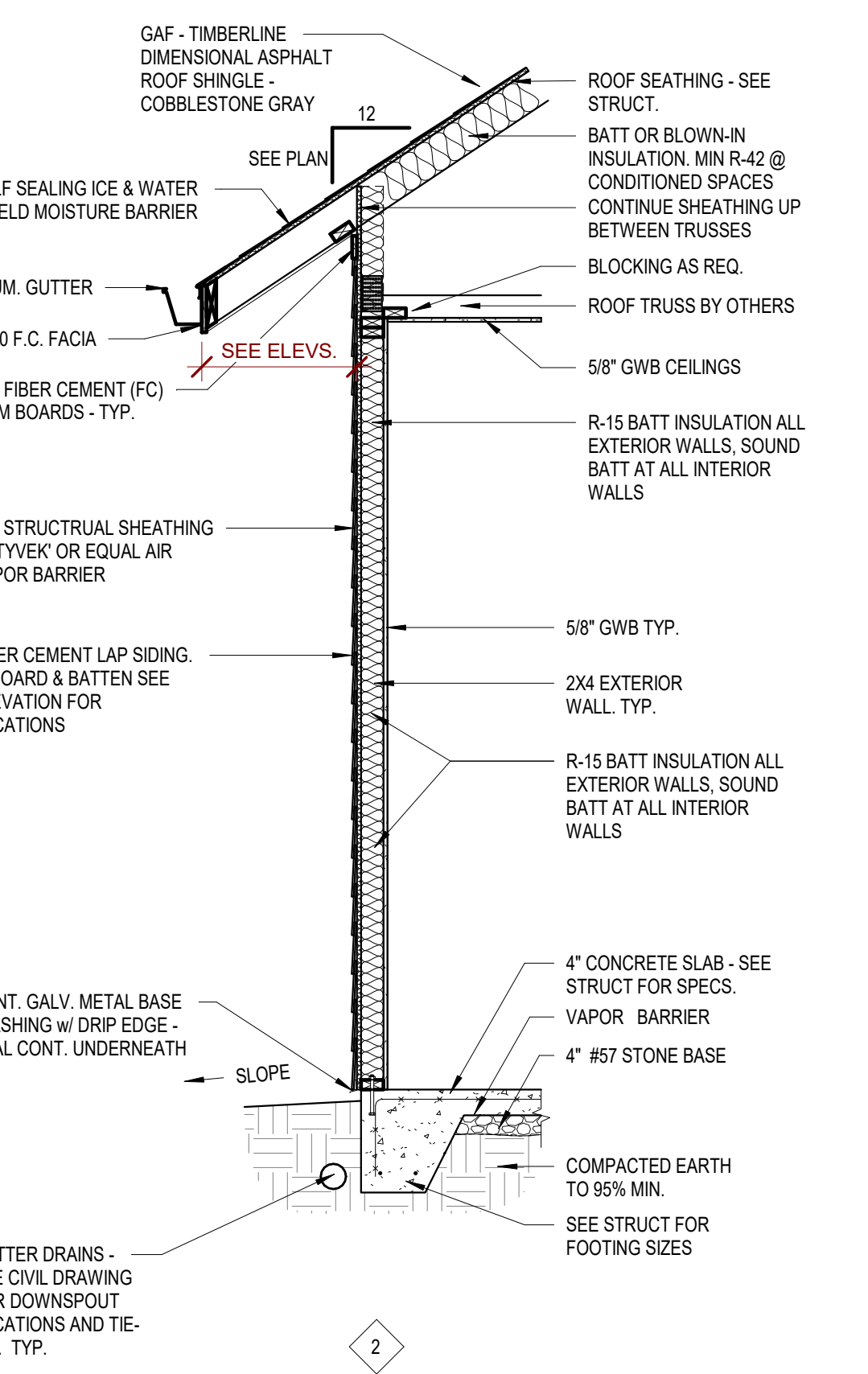

1
A3.1
Typical Wall Sections
1/2" = 1'-0"



D. CLUGSTON

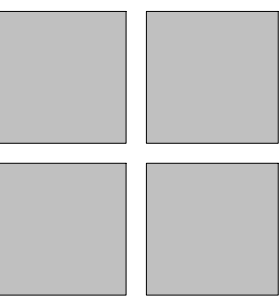
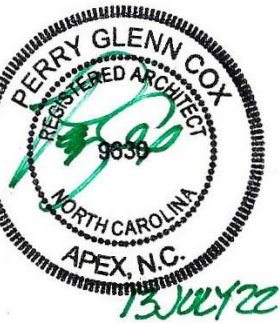

Perry Cox architect, p.a.
124 Salem Towne Court, Apex, NC 27502
P. 919.363.5411
www.pcoxdesign.com

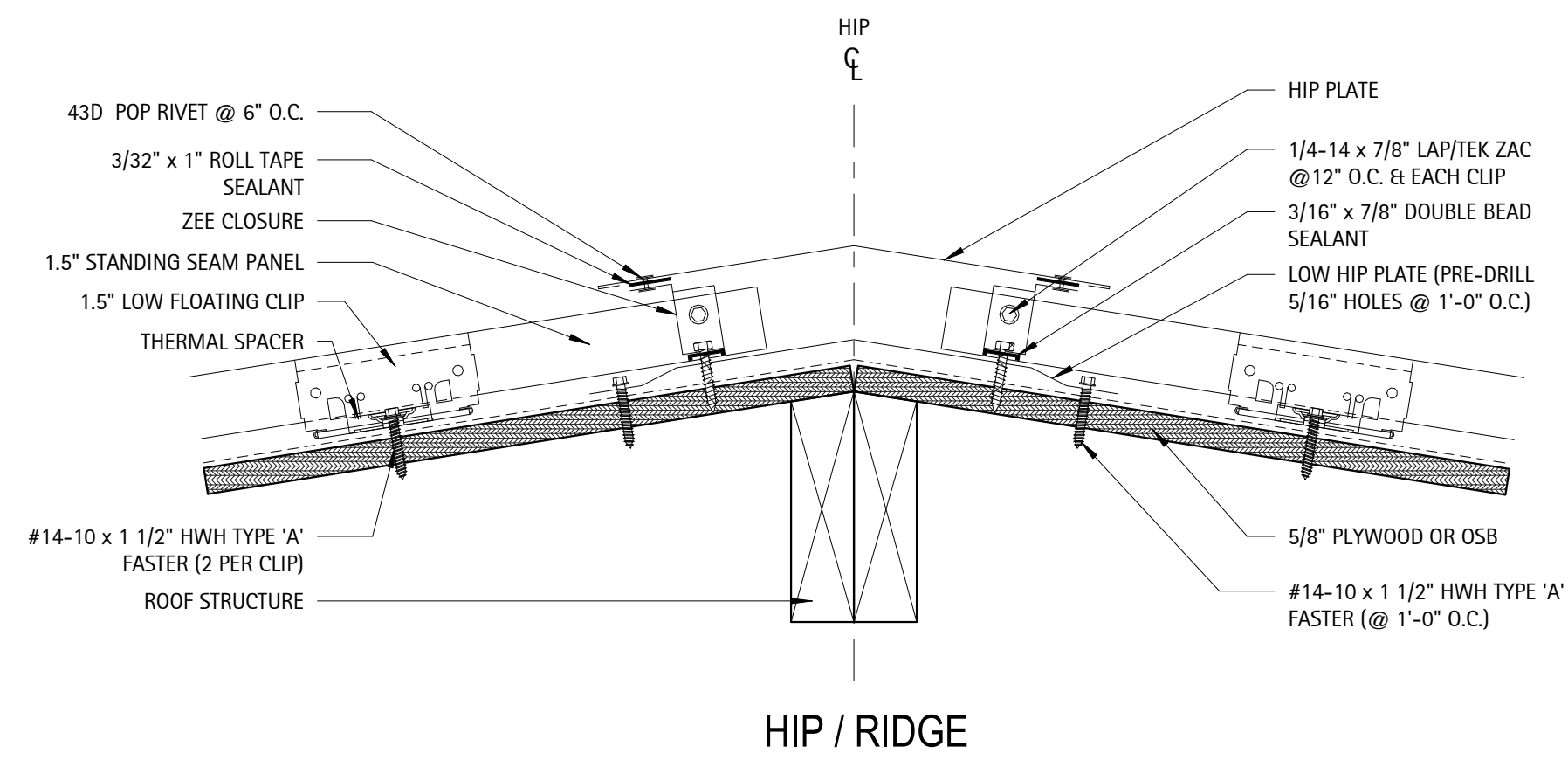

HIP / RIDGE

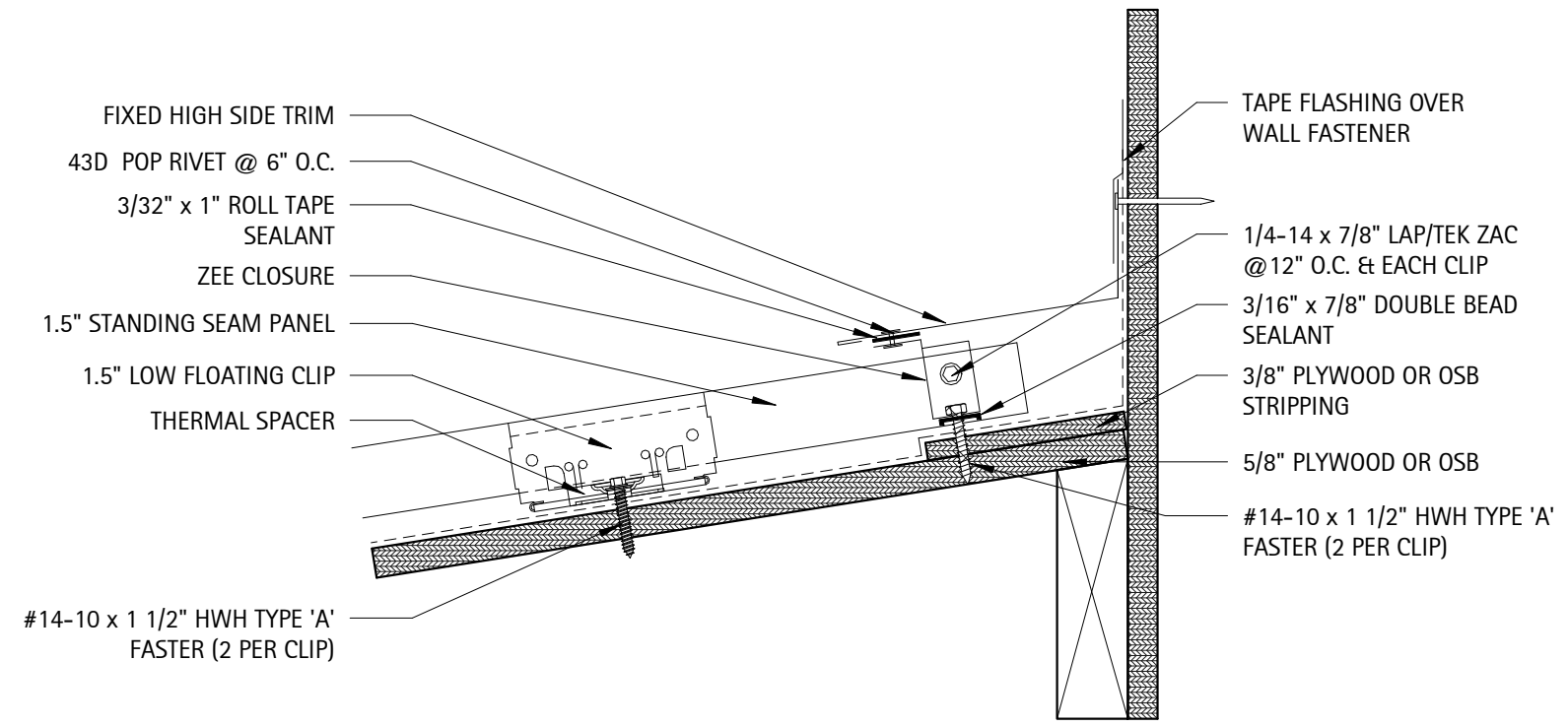

HIGH SIDE TIE-IN

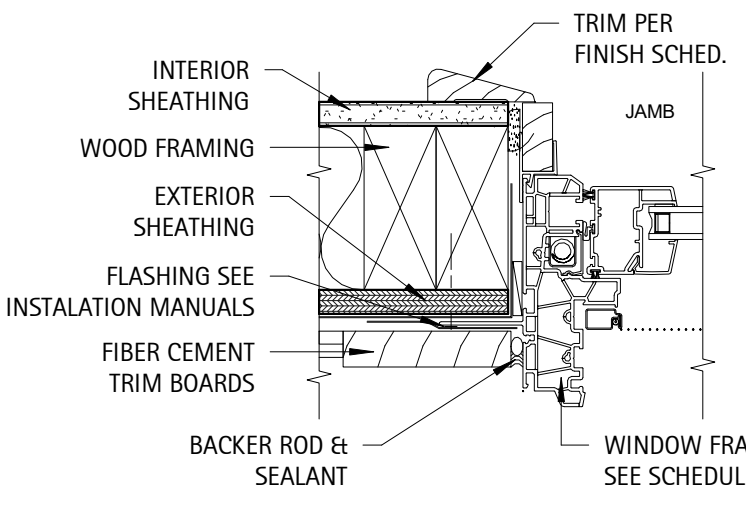

WINDOW TREATMENT @ SIDING

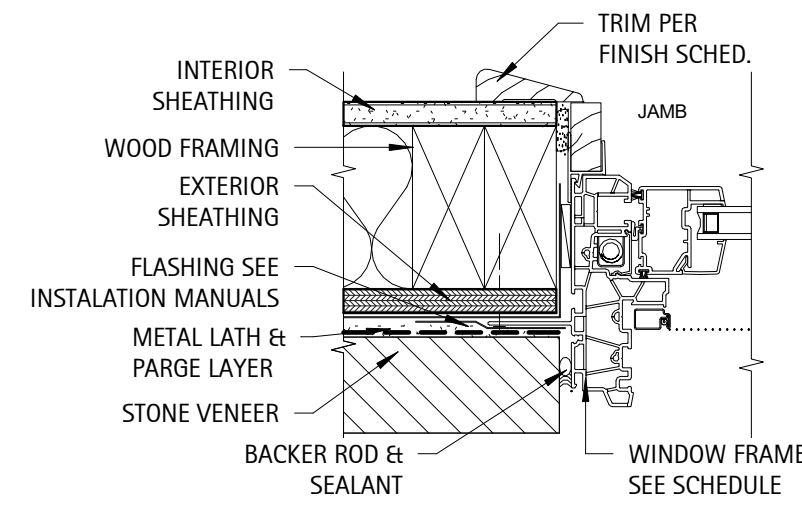

WINDOW TREATMENT @ STONE

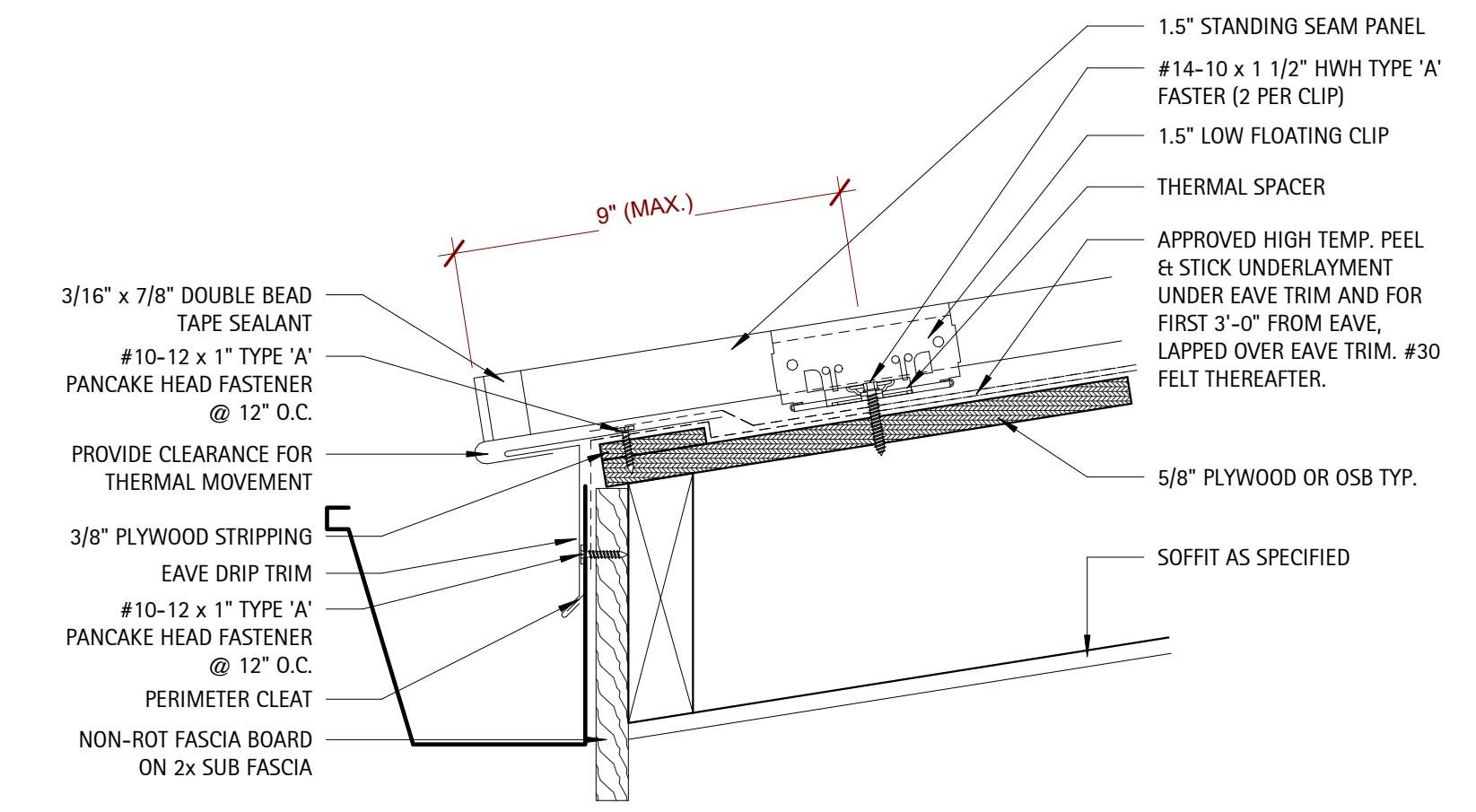

EAVE WITH GUTTER

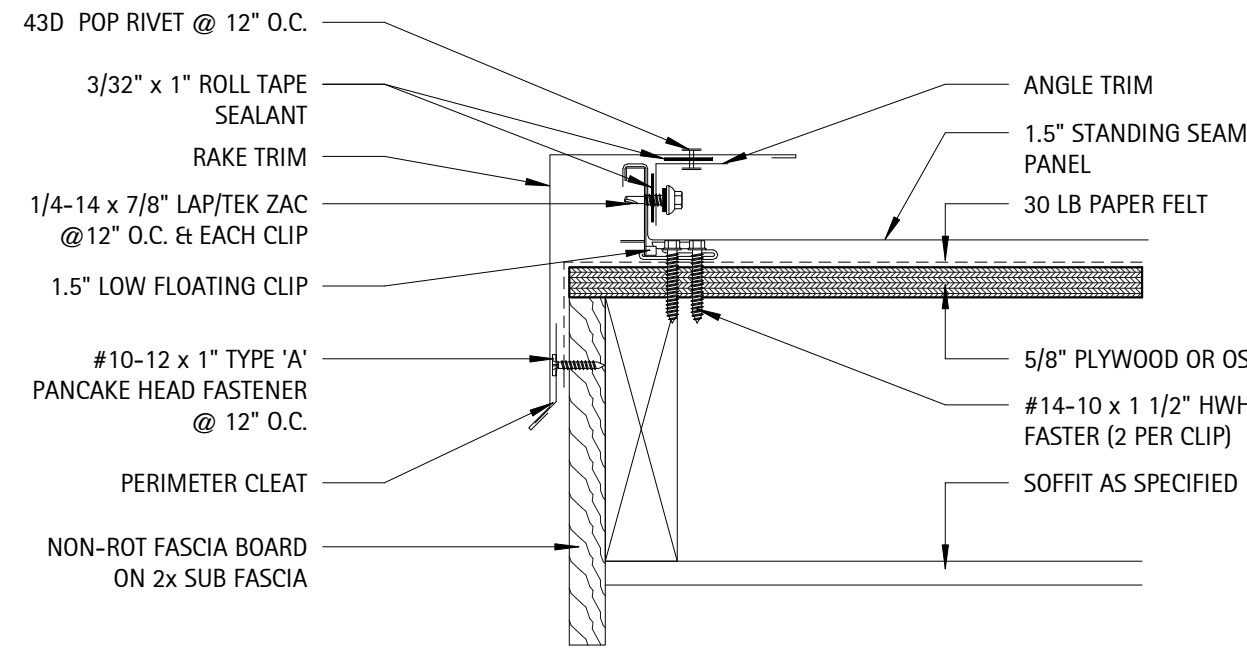

TYPICAL RAKE TRIM

3 Detail - Standing Seam Roof
A4.0 3" = 1'-0"

2 Detail - Window Treatments
A4.0 3" = 1'-0"

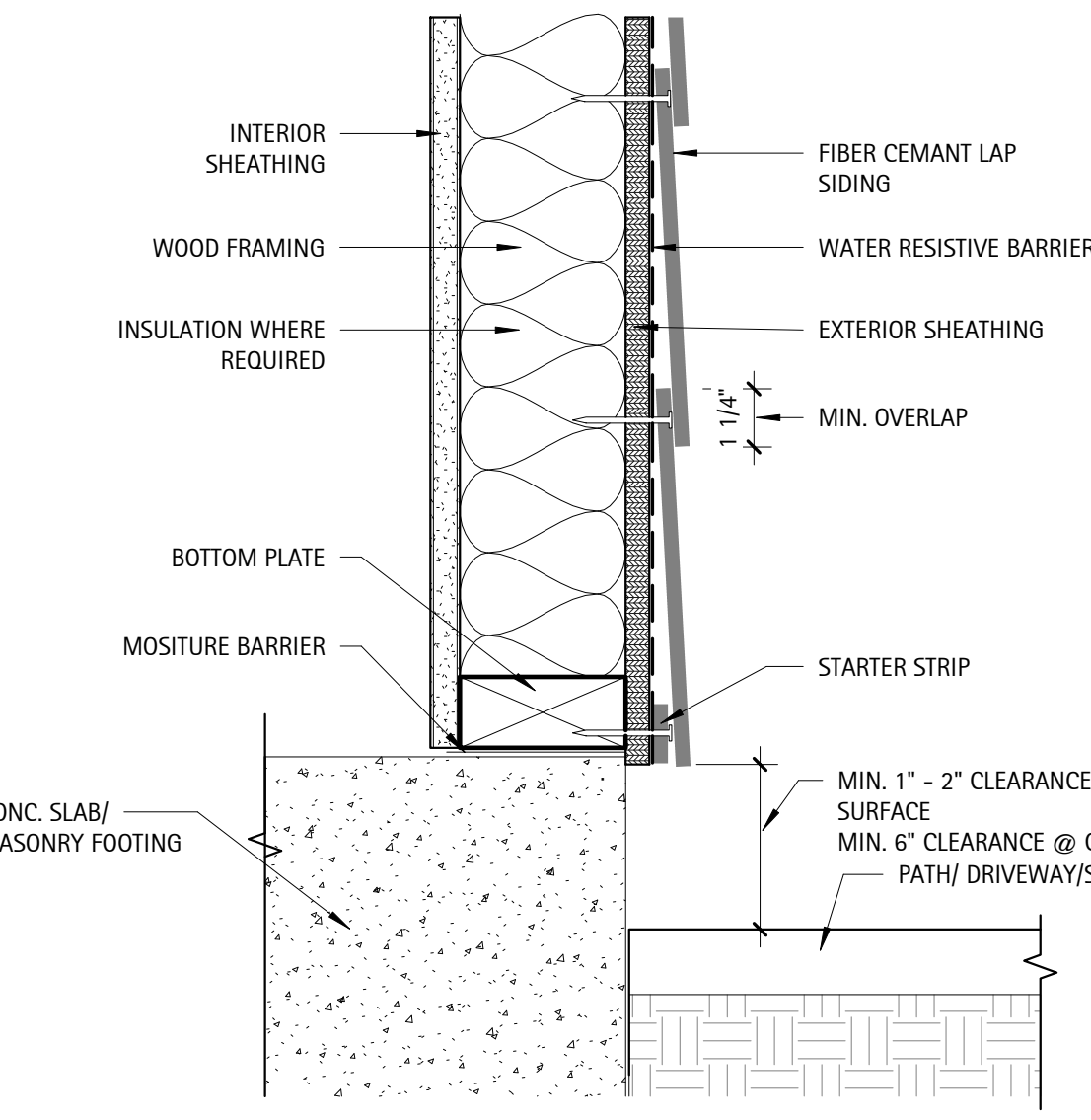

SIDING @ FOUNDATION

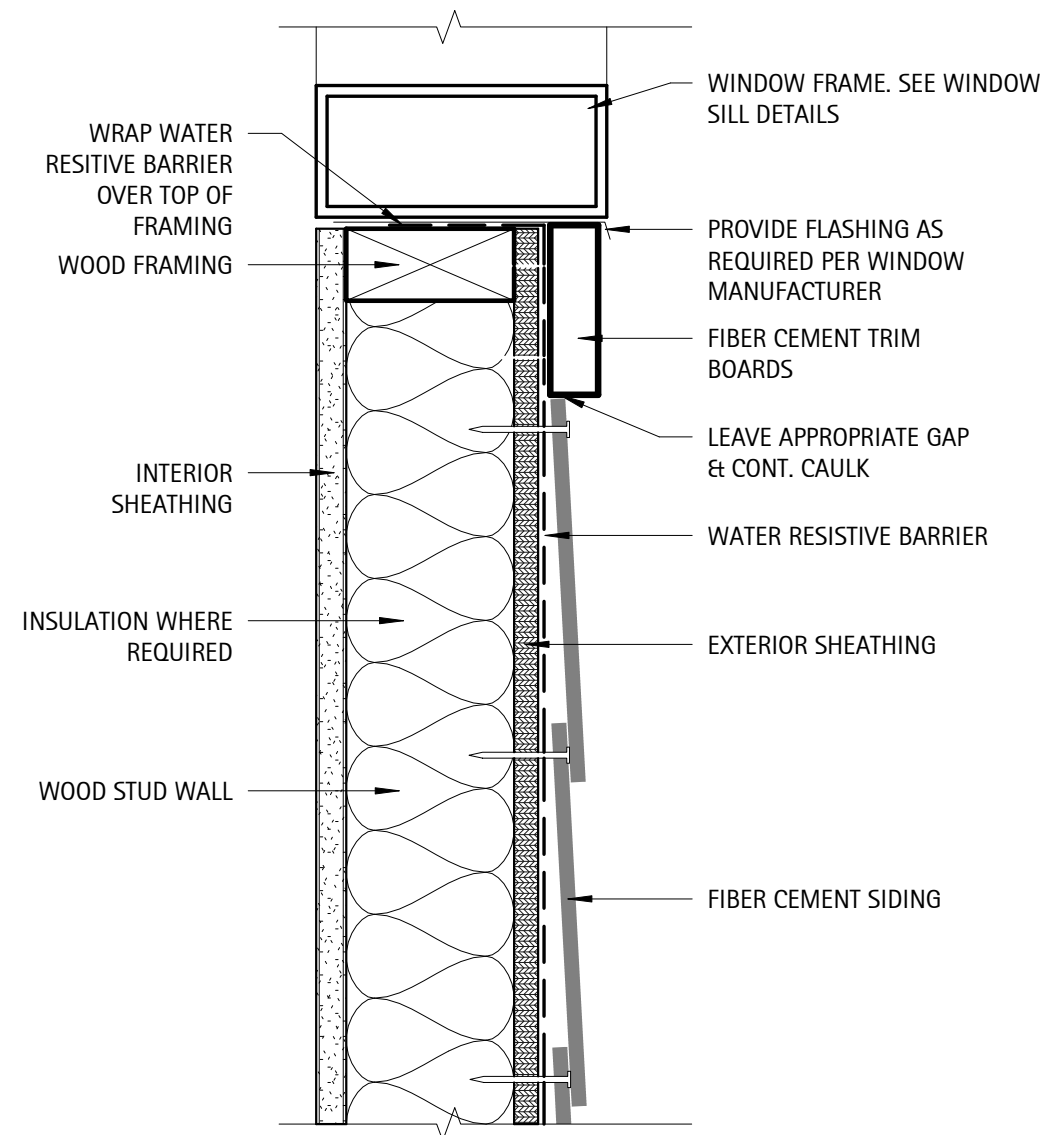

TYPICAL WINDOW SILL TRIM

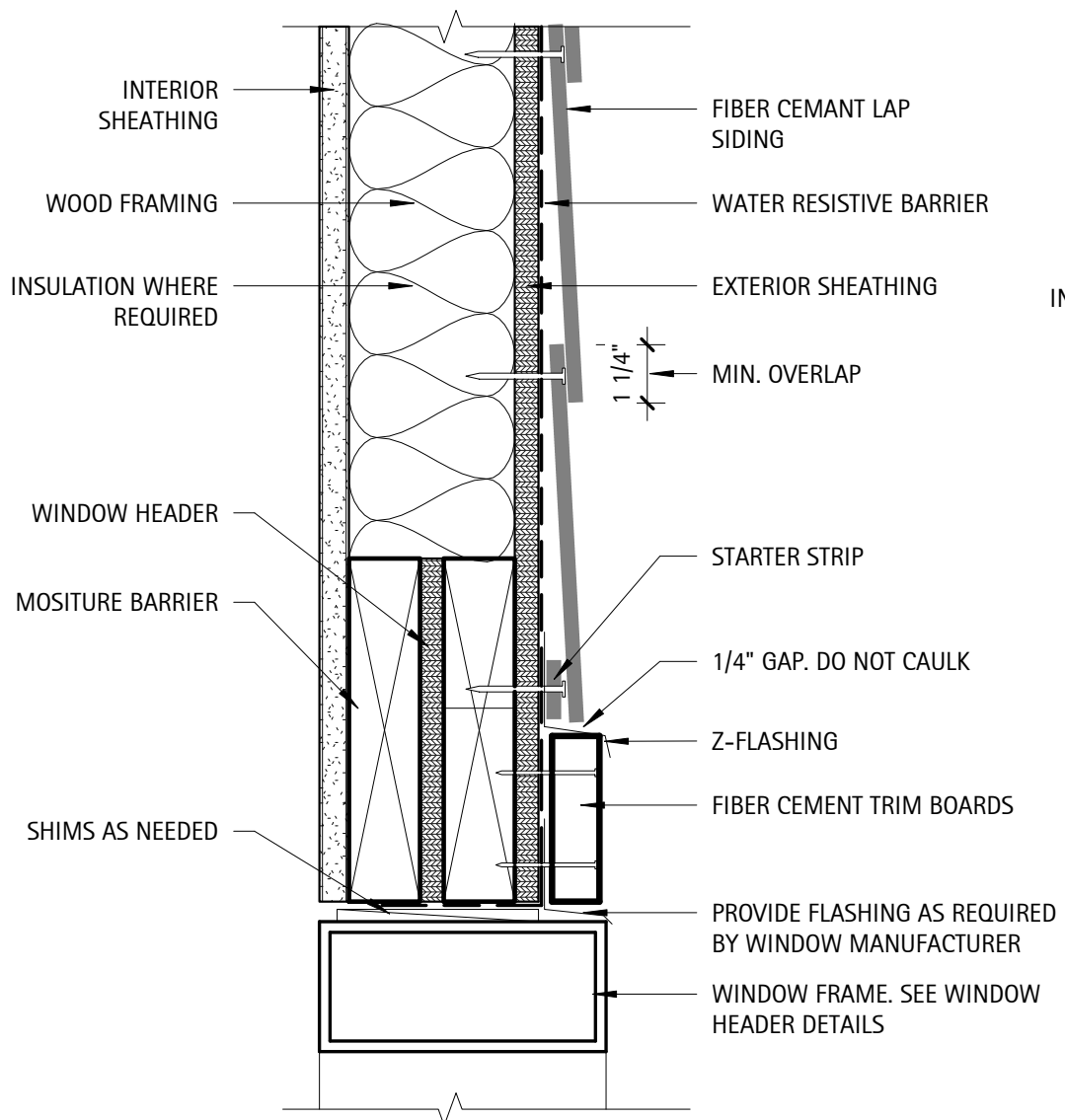

TYPICAL WINDOW HEADER TRIM

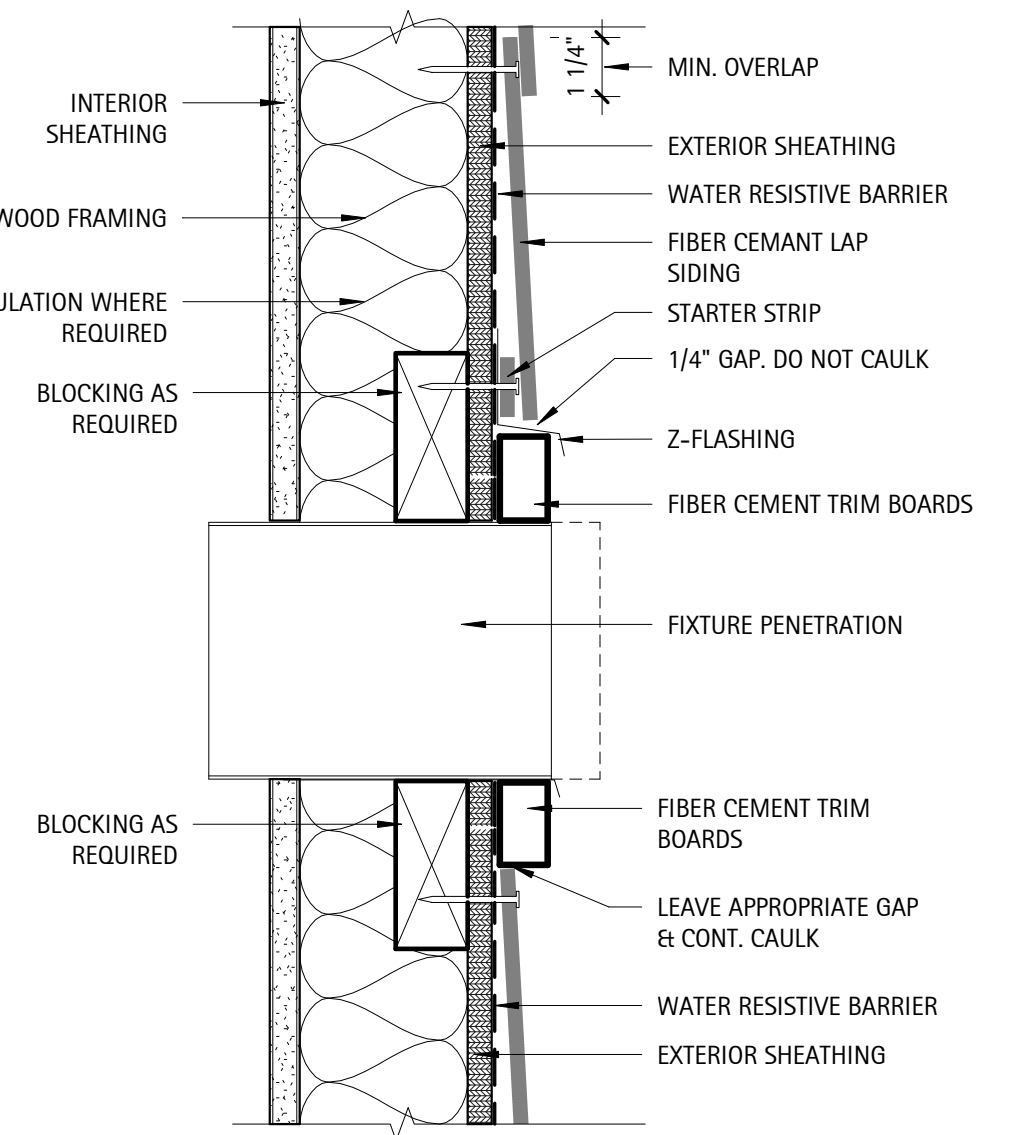

TYPICAL FIXTURE TRIM

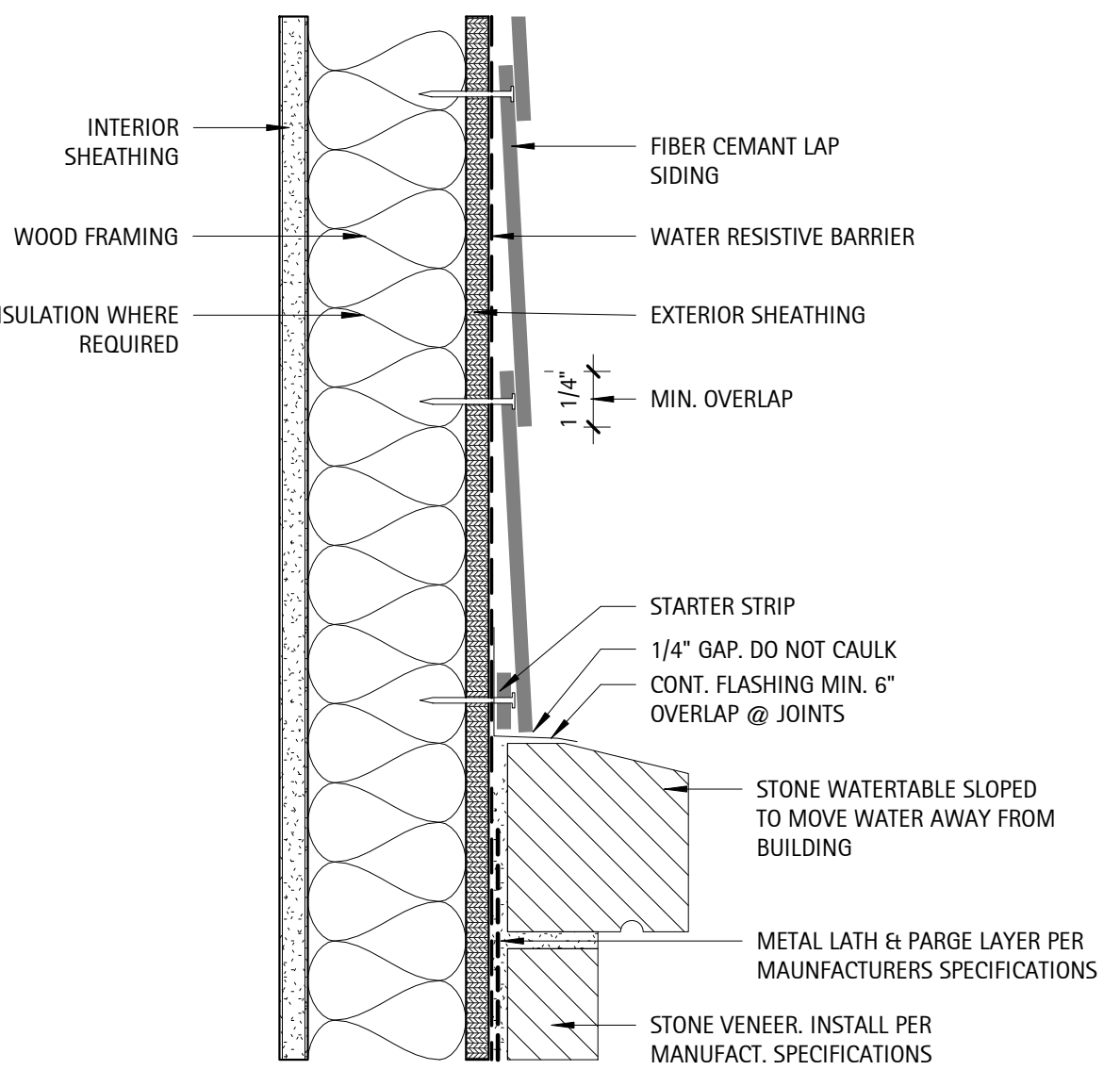

SIDING @ STONE VENEER

1 Detail - Fiber Cement Siding
A4.0 3" = 1'-0"

DATE
REVISION
NO.

SHEET DESCRIPTION

General Building Details

PROJECT #: 2022002
DATE ISSUED: 07/20/2022
DRAWING BY: JGM/BSJ
CHECKED BY: PGC/DSC

WOODGROVE
DR HORTON
BATHHOUSE & POOL
HARNETT COUNTY, NC

A4.0

DOORS, FRAMES, HARDWARE NOTES

- Refer to Door and Hardware Schedule for extent, type and additional notes. Acceptable wood door manufacturers to be Weyerhaeuser, Eggers, Mohawk or Architect approved equal. General Contractor shall provide a hardware schedule and catalogue cuts for all finish hardware for approval by the Architect indicating location of hardware set, cross-referenced to indications on Drawings, manufacturer's name and product number, finish, and other similar information describing hardware to be provided. Items of hardware not definitely specified, but needed for satisfactory installation of hardware shall be provided. Such items shall be of type and quality suitable for service needed and comparable to adjacent hardware.
- All doors shall be set 6" off adjacent perpendicular wall, UON. Doors shall not be undercut, UON. All levers, pulls, and locks are to be provided per the schedule. All hinges and other miscellaneous exposed hardware shall be in similar and compatible finishes as indicated on Hardware Schedule.
- General Contractor shall coordinate keying system with Owner (Building Management), Landlord, and Architect. General Contractor shall coordinate security system with system vendor and scheduled hardware and the submittal of all security hardware specifications and cut sheets to the proper authorities for review and approval during building permit process.
- Provide hardware, door pulls, hinges, closers, electromagnetic devices, etc. needed to provide a full and complete installation. Provide silencers at metal frame doors. Provide floor mounted door stops unless existing conditions require wall mounted. Ensure adequate blocking for wall mounted stops. Submit to Architect for approval.
- Provide 4 1/2 x 4 1/2, full mortise, template, 5-knuckle, heavy duty, button tip hinges with non-rising loose pins and anti-friction, ball type bearing. Doors with locksets shall be furnished with non-removable pins hinges. Provide 1-1/2" pair hinges for doors up to 90" in height. Add 1 hinge for every additional 30" in height.
- Heavy duty cylindrical locksets and latchsets shall conform to ANSI A156.2, Series 4000, Grade 1. Functions as listed in schedule. Heavy duty mortise locksets and latchsets, levers shall conform to ANSI A156.13 Series, 1000, Grade 1. Overhead Closers shall be surface mounted or concealed overhead as noted in the hardware schedule and shall be heavy duty, fully hydraulic, rack and pinion action and sized to be in compliance with requirements for accessibility for handicapped and recommendations of manufacturer. Furnish complete with all necessary hardware. Furnish 2 keys per lock with a maximum of 8 keys per keyed alike set. Before final completion, adjust hardware so that doors operate in perfect order. Test and adjust hardware for quiet, smooth operation and adjust closers for proper operation. At final completion, properly tag and identify keys and deliver to Owner.
- All Hardware shall be medium grade commercial if not otherwise noted or specified. See allowance per door.
- All interior egress doors and a minimum of one exterior egress door shall be readable openable from the egress side without use of a key or special knowledge.
- All Glazing within 24" of either side of a door in a closed position, and on the same wall plane shall be tempered. Tempered glass shall be installed by code in the following locations:
 - Door Glazing;
 - Glazing for bathroom fixture enclosures (showers, etc)
 - Glazing less than 60" above tub and shower drains;
 - Glazing within 24" of an adjacent door w/ sill less than 60 degrees;
 - Individual panels of Glazing greater than 9 sqft and sill less than 18" above floor and top edge greater than 36".
- Provide an interior door signage allowance of \$25.00 per door.
- Fire Extinguisher cabinets shall be similar to J.L. Industries Mod. Clear VU 1525F26 with a clear bubble and A#10 S/S Finish, ADA approved and mounted. Place where shown on plans (FX)
- Door closers shall be LCN series 4040 or equivalent

ROOM SCHEDULE								
Room Number	Room Name	Floor Finish	Base Finish	Wall Finish	Ceiling Finish	Ceiling Height	Crown	Comments
100	ENTRY	Concrete - Light Broom	N/A	N/A	Hardie Panels or EQ - Painted	10'-0"	No	Slope all floors away from building walls at min. 1/8" per 1'-0"
101	HALL	Concrete - Light Broom	N/A	N/A	Hardie Panels or EQ - Painted	10'-0"	No	
102	STORAGE	Concrete - Light Broom	1x8 Fiber Cement - Painted	MR GWB - Painted	MR GWB - Painted	10'-0"	No	
103	ELEC.	Concrete - Light Broom	1x8 Fiber Cement - Painted	MR GWB - Painted	MR GWB - Painted	10'-0"	No	
104	MENS	Acrylic Chip Flooring	1x8 Fiber Cement - Painted	MR GWB - Painted	MR GWB - Painted	10'-0"	No	Slope all floors to drain
105	PUMP ROOM	Concrete - Light Broom	1x8 Fiber Cement - Painted	MR GWB - Painted	MR GWB - Painted	10'-0"	No	Slope all floors to sump
106	WOMENS	Acrylic Chip Flooring	1x8 Fiber Cement - Painted	MR GWB - Painted	MR GWB - Painted	10'-0"	No	Slope all floors to drain
107	CHEM.	Concrete - Light Broom	1x8 Fiber Cement - Painted	MR GWB - Painted	MR GWB - Painted	10'-0"	No	Provide non-rot chemical shelf at 16" A.F.F.
108	COVERED PORCH	Concrete - Light Broom	N/A	N/A	Hardie Panels or EQ - Painted	10'-0"	No	Slope all floors away from building walls at min. 1/8" per 1'-0"
109	COVERED PAVILLION	Concrete - Light Broom	N/A	N/A	Hardie Panels or EQ - Painted	Varies	No	

DOOR SCHEDULE																											
Door Number	Style	Door					Rough Width	Rough Height	Door		Frame	Fire Rating	Push / Pull	Passage Set	Privacy Set	Office Set	Storage Set	Deadbolt	Hardware				Threshold	FOB Access	Time Lock	Comments	
		Material	Finish	Material	Finish	Panic Hardware			Closer	Weather strip																	
103	Type A	3' - 0"	7' - 0"	0' - 1 3/4"	3' - 2 1/2"	7' - 1 1/4"	Metal	Paint	HM	N/A	No	No	No	No	No	No	No	No	No	No	No	Yes	Yes	Yes	No	No	
104	Type A	3' - 0"	7' - 0"	0' - 1 3/4"	3' - 2 1/2"	7' - 1 1/4"	Metal	Paint	HM	N/A	Yes	No	No	No	No	No	Yes	No	Yes	Yes	Yes	Yes	Yes	No	Yes	Timelock from dawn to dusk. Coordinate with H.O.A.	
105	Type B	3' - 6"	7' - 0"	0' - 1 3/4"	3' - 8 1/2"	7' - 1 1/4"	Metal	Paint	HM	N/A	No	No	No	No	Yes	No	No	No	No	No	No	Yes	Yes	Yes	No	No	See Mech for Vent Req. - w/ Placards per NFPA704
106	Type A	3' - 0"	7' - 0"	0' - 1 3/4"	3' - 2 1/2"	7' - 1 1/4"	Metal	Paint	HM	N/A	Yes	No	No	No	No	No	Yes	No	Yes	Yes	Yes	Yes	Yes	No	Yes	Timelock from dawn to dusk. Coordinate with H.O.A.	
107	Type B	3' - 0"	7' - 0"	0' - 1 3/4"	3' - 2 1/2"	7' - 1 1/4"	Metal	Paint	HM	N/A	No	Yes	No	No	No	No	No	No	No	No	No	No	No	No	No	See Mech for Vent Req. - w/ Placards per NFPA704	
G100	Type C	4' - 0"	6' - 0"				Metal	Paint	Metal	N/A	Yes	No	No	No	No	No	Yes	Yes	Yes	No	No	Yes	No	Yes	No	Gate: See Pool Details	
G101	Type C	4' - 0"	6' - 0"				Metal	Paint	Metal	N/A	Yes	No	No	No	No	No	Yes	Yes	No	No	No	Yes	No	Yes	No	Gate: See Pool Details	
G102	Type C	4' - 0"	6' - 0"				Metal	Paint	Metal	N/A	Yes	No	No	No	No	No	Yes	Yes	No	No	No	Yes	No	Yes	No	Gate: See Pool Details	
G103	Type C	4' - 0"	6' - 0"				Metal	Paint	Metal	N/A	Yes	No	No	No	No	No	Yes	Yes	No	No	No	Yes	No	Yes	No	Gate: See Pool Details	
Grand total: 9																											

WINDOW SCHEDULE									
Mark	Count	Size		Rough Width	Rough Height	Type	Finish	Head Height	Comments
		Width	Height						
A	4	3' - 0"	5' - 0"	3' - 0 1/2"	5' - 0 1/2"	TYPE A		8'-0"	Frosted
B	8	3' - 0"	2' - 0"	3' - 0 1/2"	2' - 0 1/2"	TYPE B		Varies	

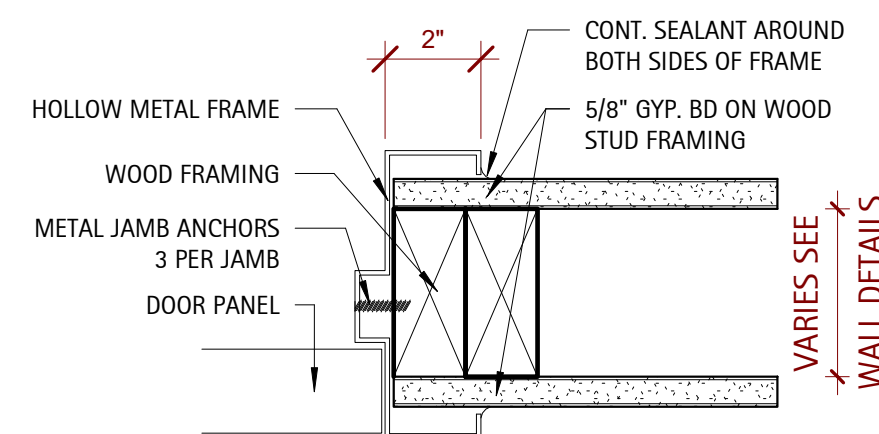

INTERIOR DOOR JAMB

4 Detail - Typ. Door Jambs
3" = 1'-0"

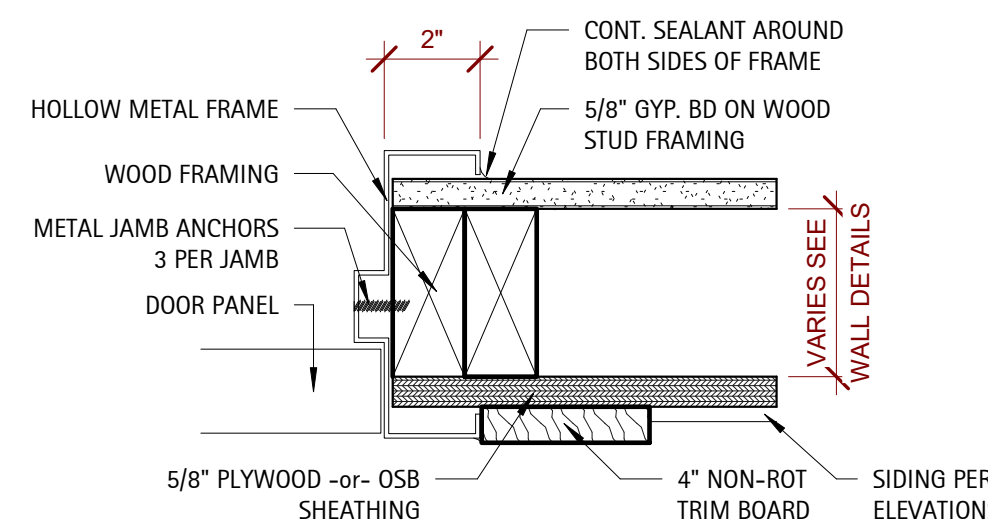

EXTERIOR DOOR JAMB

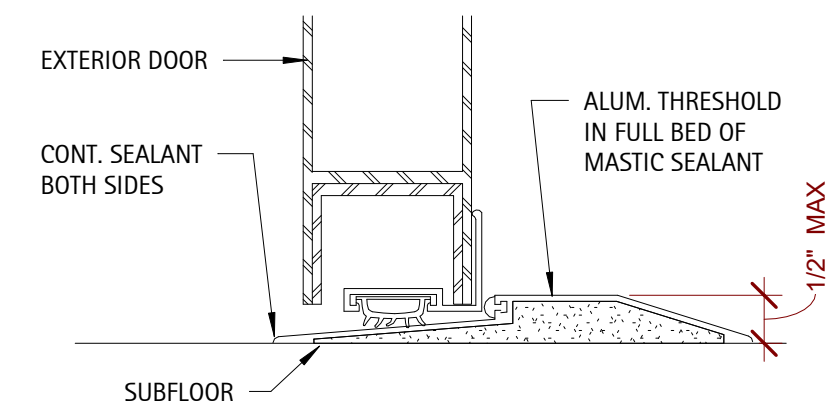

EXTERIOR DOORS THRESHOLD

3 Detail - Typ. Threshold
6" = 1'-0"

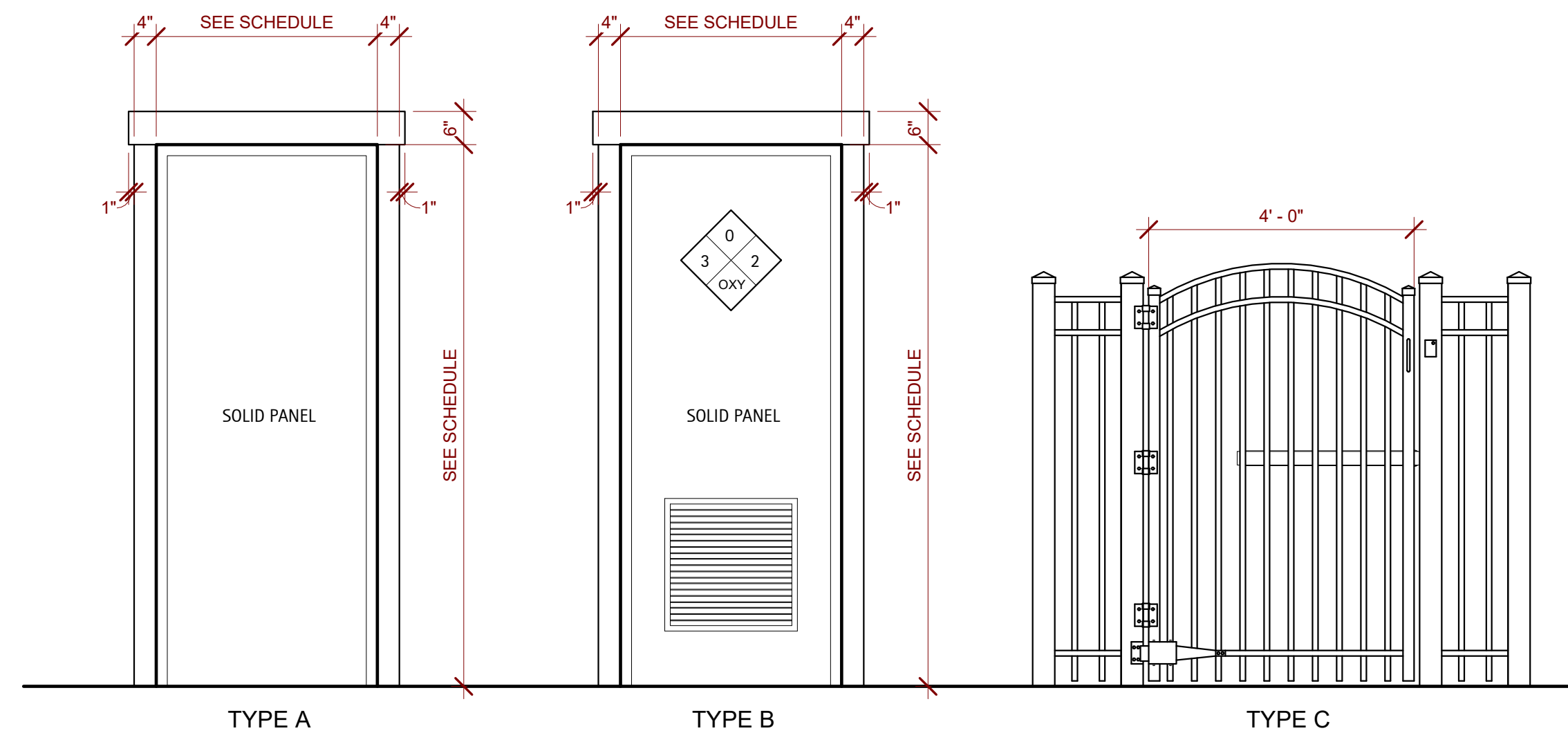

2 Detail - Door Frames
1/2" = 1'-0"

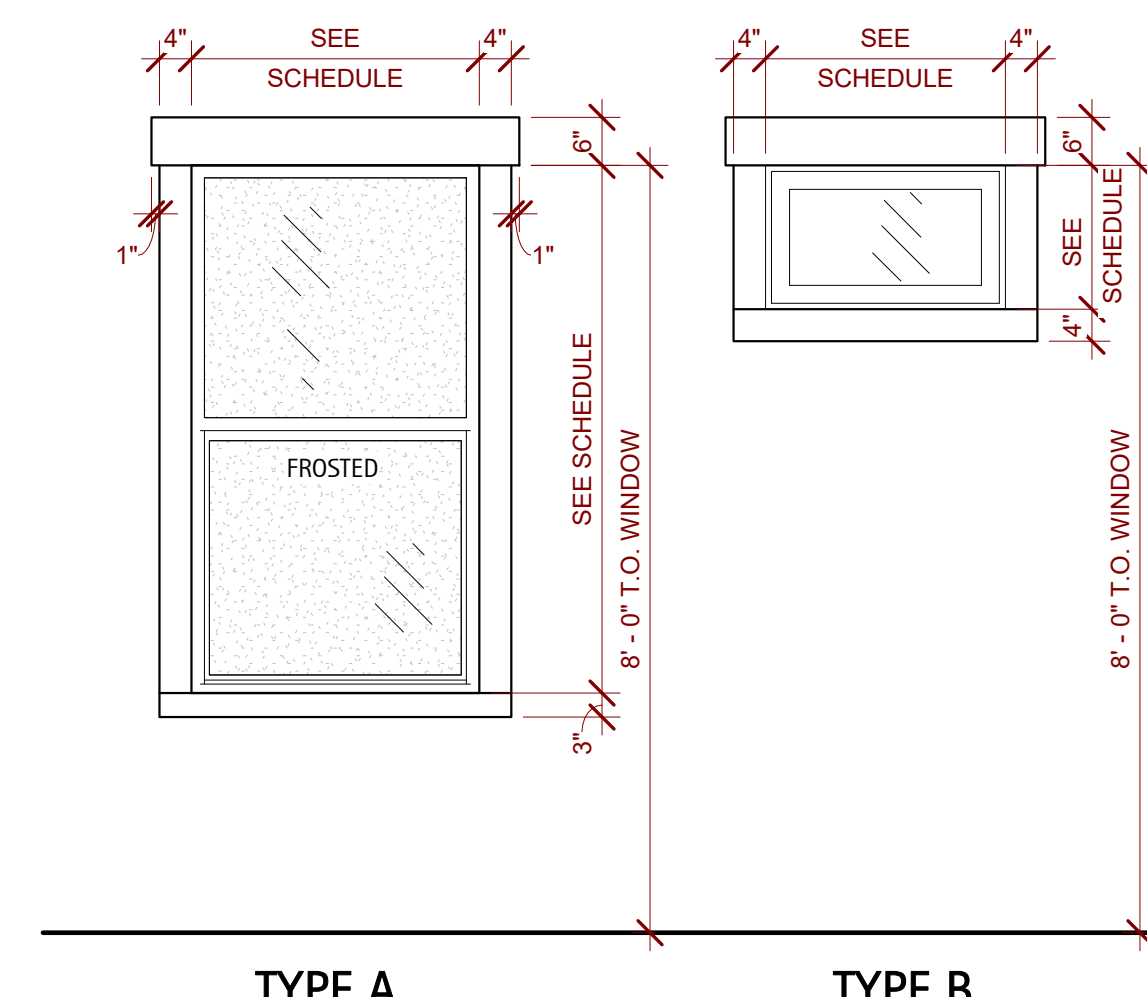

1 Detail - Window Types
1/2" = 1'-0"

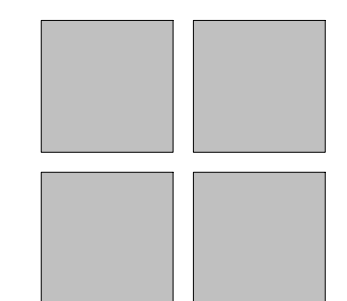
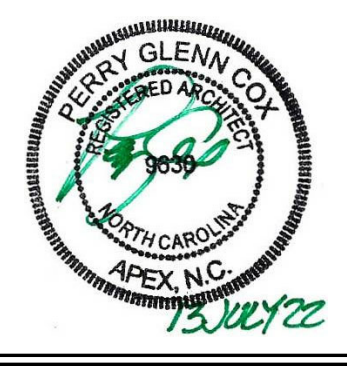

Perry Cox
architect, p.a.
124 Salem Towne Court, Apex, NC 27502
P. 919.363.5411
www.pcoxdesign.com

DATE	
REVISION	
NO.	

SHEET DISCRPTION
Schedules & Details

PROJECT #: 2022002
DATE ISSUED: 07/20/2022
DRAWING BY: JGM/BSJ
CHECKED BY: PGC/DSC

**WOODGROVE
DR HORTON
BATHHOUSE & POOL
HARNETT COUNTY, NC**

A5.0

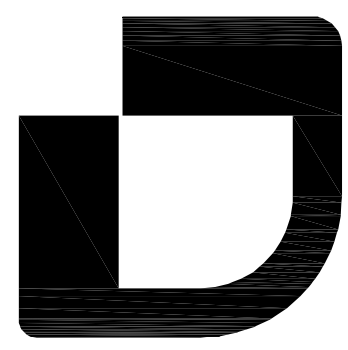

D. CLUGSTON

ROSS LINDEN ENGINEERS PC
709 W. JONES STREET RALEIGH, NC 27603
TEL: 919.832.5680 FAX: 919.832.5675
WWW.ROSSLINDEN.COM NC LICENSE NO. C-2164

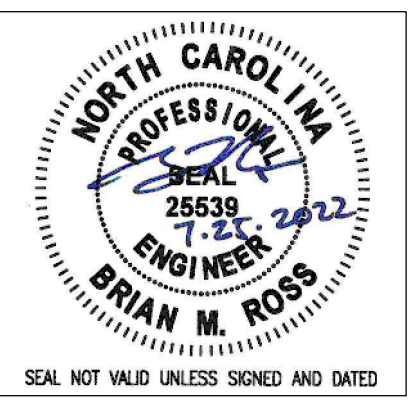

Copyright Ross Linden Engineers PC 2022. All rights reserved.

DATE	
REVISION	
NO.	

SHEET DESCRIPTION

Slab and Foundation Plan

PROJECT #: C220702

DATE ISSUED: 07/22/2022

DRAWING BY: BR

CHECKED BY: BR/JM/BJ

WOODGROVE
NEST COMMUNITIES
BATHHOUSE & POOL
HARNETT COUNTY, NC

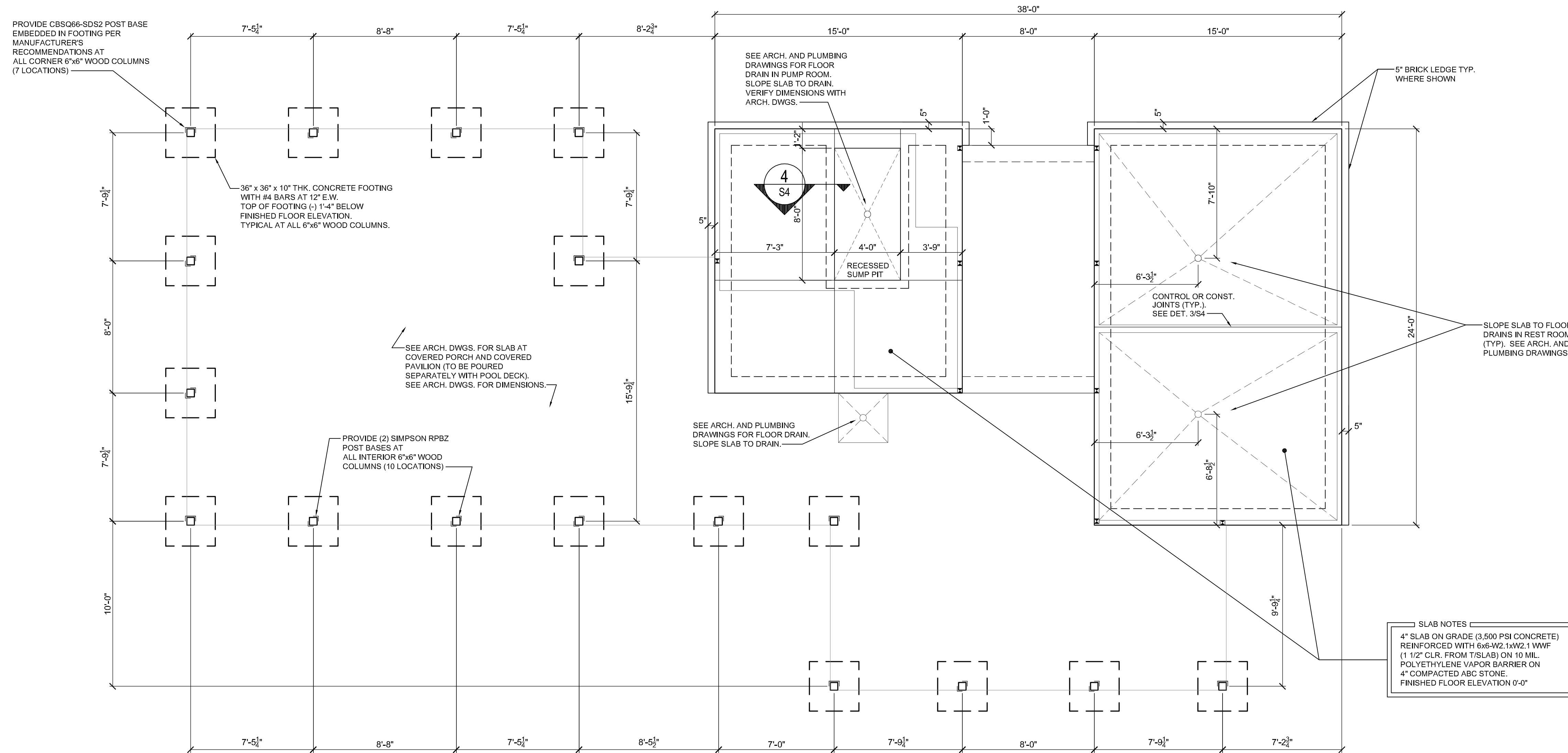

SLAB NOTES

4" SLAB ON GRADE (3,500 PSI CONCRETE)
 REINFORCED WITH 6x6-W2, W#2, 1 WWF
 (1 1/2" CLR. FROM T/SLAB) ON 10 MIL
 POLYETHYLENE VAPOR BARRIER ON
 4" COMPACTED ABC STONE.
 FINISHED FLOOR ELEVATION 0'-0"

1 SLAB AND FOUNDATION PLAN
 S1 1/4" = 1'-0"



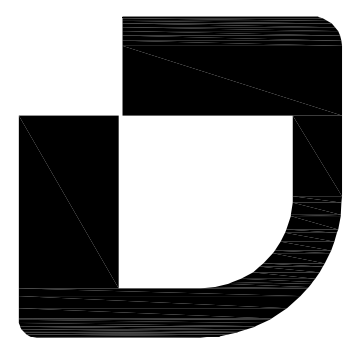

D. CLUGSTON

ROOF TRUSS SYSTEM
 TRUSS LAYOUT AND PLACEMENT BY
 MANUFACTURER TO COINCIDE WITH THE
 SUPPORT LOCATIONS SHOWN. TRUSS
 PROFILES SHALL BE ENGINEERED AND SEALED
 BY THE TRUSS MANUFACTURER. TRUSS PLANS
 SHALL BE PROVIDED FOR REVIEW AND
 COORDINATED WITH THE ENGINEER OF
 RECORD PRIOR TO CONSTRUCTION.
 INSTALLATION SHALL BE IN ACCORDANCE WITH
 THE MANUFACTURER'S INSTRUCTIONS.

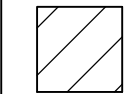
 DENOTES ROOF TRUSS
 OVERFRAMED AREA

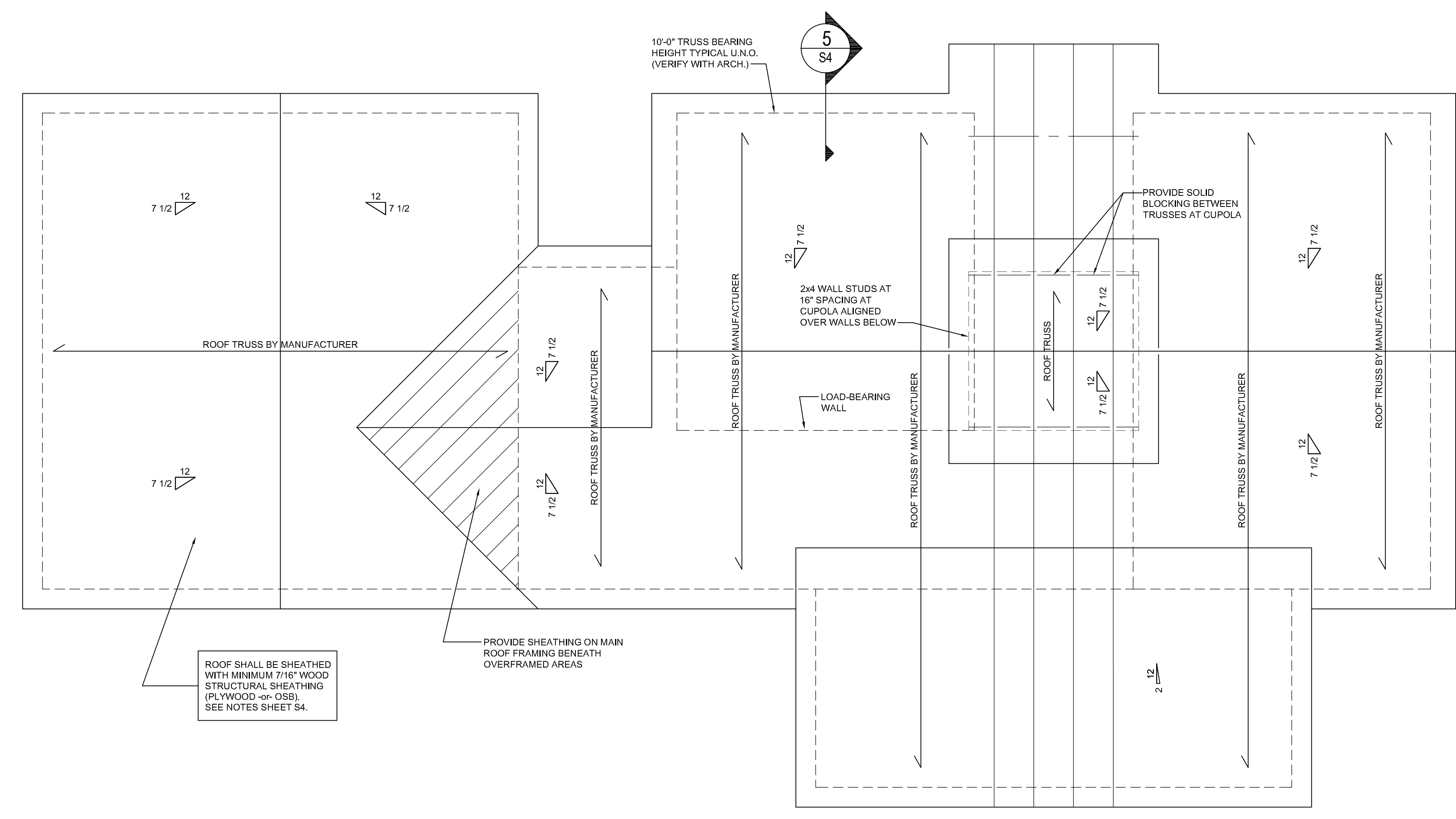

ROOF SHALL BE SHEATHED
 WITH MINIMUM 7/16" WOOD
 STRUCTURAL SHEATHING
 (PLYWOOD -or- OSB).
 SEE NOTES SHEET S4.

1 ROOF FRAMING PLAN
 S3 1/4" = 1'-0"



ROSS LINDEN
 ENGINEERS PC
 709 W. JONES STREET RALEIGH, NC 27603
 TEL: 919.832.5680 FAX: 919.832.5675
 WWW.ROSSLINDEN.COM NC LICENSE NO. C-2164

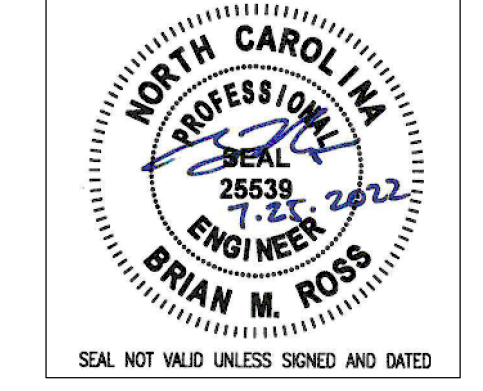

Copyright Ross Linden Engineers PC
 2022. All rights reserved.

NO.	REVISION	DATE

SHEET DESCRIPTION
Roof Framing Plan

PROJECT #: C220702
 DATE ISSUED: 07/22/2022
 DRAWING BY: BR
 CHECKED BY: BR/JM/BJ

WOODGROVE
 NEST COMMUNITIES
 BATHHOUSE & POOL
 HARNETT COUNTY, NC

STRUCTURAL NOTES

I. GENERAL

- DESIGN CODES
 - NORTH CAROLINA BUILDING CODE, 2018 EDITION (AMENDED 2015 INTERNATIONAL BUILDING CODE)
 - ACI BUILDING CODE REQUIREMENTS FOR STRUCTURAL CONCRETE (ACI 318-14)
 - AISC MANUAL OF STEEL CONSTRUCTION - ALLOWABLE STRESS DESIGN NINTH EDITION
 - ASCE 7-10 MINIMUM DESIGN LOADS FOR BUILDINGS AND OTHER STRUCTURES
- DESIGN LOADS
 - LIVE LOADS: FLOOR: 100 PSF ROOF: 20 PSF
 - ULTIMATE DESIGN WIND SPEED: 117 MPH
 - GROUND SNOW LOAD 15 PSF
 - SEISMIC DESIGN CATEGORY C SITE CLASS D
 - Ss = 0.190 S1 = 0.088
- ALL ELEVATIONS ARE REFERENCED FROM FINISHED FLOOR ELEVATION OF 0'-0". SEE ARCHITECTURAL DRAWINGS FOR ADDITIONAL INFORMATION.
- DETAILED SHOP DRAWINGS SHALL BE PROVIDED FOR REVIEW AND APPROVAL PRIOR TO CONSTRUCTION.
- ENGINEER'S SEAL APPLIES TO STRUCTURAL COMPONENTS ONLY AND DOES NOT CERTIFY ARCHITECTURAL LAYOUT OR DIMENSIONAL ACCURACY.
- ROSS LINDEN ENGINEERS PC ASSUMES NO LIABILITY FOR CHANGES OR MODIFICATIONS MADE TO THESE DRAWINGS BY OTHERS, OR FOR CONSTRUCTION METHODS, OR FOR ANY DEVIATION FROM THESE DRAWINGS.

II. CONCRETE

- UNLESS OTHERWISE NOTED, ALL CONCRETE SHALL HAVE THE FOLLOWING STRENGTH AND SLUMP REQUIREMENTS: 3,500 PSI 28-DAY COMPRESSIVE STRENGTH, MAX. 5" SLUMP.
- ALL CONCRETE SHALL BE MOIST CURED PER ACI 301 OR CURED WITH AN APPROVED CURING COMPOUND. CONTRACTOR SHALL VERIFY THAT THE CURING COMPOUND IS COMPATIBLE WITH FLOOR COVERING ADHESIVES, COATINGS, OR TOPPING TO BE USED. CONCRETE SHALL BE CURED FOR A MINIMUM OF 7 DAYS.
- UNLESS OTHERWISE NOTED, ALL REINFORCING STEEL SHALL BE NEW BILLET STEEL, CONFORMING TO ASTM A-615, GRADE 60, DEFORMED.
- UNLESS OTHERWISE NOTED, ALL DETAILING, FABRICATION, AND PLACING OF REINFORCING STEEL SHALL CONFORM TO THE MANUAL OF STANDARD PRACTICE FOR DETAILING REINFORCED CONCRETE STRUCTURES. (ACI 315)
- ALL BAR SPLICES SHALL BE CLASS "B" TENSION SPLICES PER ACI 318-14, UNLESS OTHERWISE SHOWN.
- ANCHOR BOLTS TO BE ASTM A36 OR A307.
- CONTRACTOR SHALL REFER TO DRAWINGS OF OTHER TRADES AND VENDOR DRAWINGS FOR EMBEDDED ITEMS AND RECESSES NOT SHOWN ON THE STRUCTURAL DRAWINGS.
- ALL SPREAD FOOTINGS BEARING ON NATIVE SOIL OR STRUCTURAL FILL ARE DESIGNED FOR AN ALLOWABLE BEARING PRESSURE OF 2,500 PSF. A GEOTECHNICAL REPRESENTATIVE SHALL INSPECT ALL FOOTING EXCAVATIONS TO CONFIRM ALLOWABLE BEARING PRESSURES.
- PROVIDE TWO (2) #5 x 4'-0" LONG DIAGONAL BARS IN TOP FACE OF ALL SLABS (1" CLEAR) AT ALL RE-ENTRANT CORNERS. SEE PLAN FOR LOCATIONS.
- CONTRACTOR SHALL BE RESPONSIBLE FOR LOCATING, PROTECTING, AND RELOCATING AS REQUIRED ALL SERVICE AND UTILITY LINES IN VICINITY OF THE WORK SITE.
- CONTRACTOR SHALL VERIFY ALL SIZES AND LOCATIONS OF ALL MECHANICAL AND ELECTRICAL OPENINGS AND EQUIPMENT PADS WITH THE MECHANICAL AND ELECTRICAL DETAILS AND SHOP DRAWINGS BY OTHERS. IT SHALL BE THE RESPONSIBILITY OF THE CONTRACTOR TO PROVIDE ALL OPENINGS AND SLEEVES FOR PROPER DISTRIBUTION FOR ALL UTILITIES THROUGHOUT THE BUILDING.
- ALL DOWELS WHICH ARE TO BE DRILLED AND GROUTED INTO EXISTING CONCRETE SHALL BE DONE WITH AN EPOXY GROUT. DRILL HOLE WITH DIAMETER 1/8" LARGER THAN DOWEL OR AS RECOMMENDED BY GROUT SUPPLIER. USE HIT-RE 500 V3 BY HILTI OR APPROVED EQUAL.

STRUCTURAL DESIGN

DESIGN LOADS:

Occupancy Category	II	
Importance Factors:	Wind (IW)	1.0
	Snow (IS)	1.0
	Seismic (IE)	1.0
Live Loads:	Roof	20 psf
	Mezzanine	N/A psf
	Floor	100 psf
Ground Snow Load:	15 psf	
Wind Load:	Ultimate Wind Speed	117 mph (ASCE 7-10)
	Exposure Category	B
	Wind Base Shears (for MWFRS)	Vx = 4.4K Vy = 10.0K

SEISMIC DESIGN CATEGORY A B C D

Provide the following Seismic Design Parameters:

Spectral Response Acceleration SS 0.190 %g S1 0.088 %g
 Site Classification D Field Test Presumptive Historical Data

Basic structural system (check one)
 Bearing Wall Dual w/Special Moment Frame
 Building Frame Dual w/Intermediate R/C or Special Steel Moment Frame
 Moment Frame Inverted Pendulum
 Seismic base shear VX = 1.7K VY = 1.7K
 Analysis Procedure Simplified Equivalent Lateral Force Modal
 Architectural, Mechanical, Components anchored?

Lateral design Control: Earthquake Wind

Soil Bearing Capacities:
 Field Test (provide copy of test report) _____ psf
 Presumptive Bearing capacity 2500 psf
 Pile size, type, and capacity _____

III. WOOD

- FRAMING LUMBER SHALL BE #2 SPRUCE PINE FIR (SPF) WITH THE FOLLOWING DESIGN PROPERTIES: Fb = 875 PSI Fv = 70 PSI E = 1.4E6 PSI
- FRAMING LUMBER EXPOSED TO WEATHER OR IN CONTACT WITH THE GROUND, CONCRETE OR MASONRY SHALL BE #2 SOUTHERN YELLOW PINE (SPY) TREATED IN ACCORDANCE WITH AWPA C22 WITH THE FOLLOWING DESIGN PROPERTIES: Fb = 1050 PSI Fv = 95 PSI E = 1.6E6 PSI
- ENGINEERED WOOD BEAMS SHALL BE LAMINATED VENEER LUMBER (LVL) OR PARALLEL STRAND LUMBER (PSL) WITH THE FOLLOWING MINIMUM DESIGN PROPERTIES: Fb = 2600 PSI Fv = 285 PSI E = 1.9E6 PSI
- ENGINEERED WOOD BEAMS SHALL BE INSTALLED WITH ALL CONNECTIONS PER MANUFACTURER'S INSTRUCTIONS.
- SOLID BLOCKING SHALL BE PROVIDED AT ALL POINT LOADS TO TRANSFER LOADS THROUGH FLOOR LEVELS. COLUMNS SHALL BE CONTINUOUS TO THE FOUNDATION OR TO OTHER STRUCTURAL ELEMENTS.
- WOOD SILL PLATES SHALL BE ANCHORED TO THE FOUNDATION WITH 1/2" DIAMETER ANCHOR BOLTS SPACED A MAXIMUM OF 2'-8" O.C. AND WITHIN 12" FROM THE ENDS OF EACH PLATE SECTION. PROVIDE 1/2" DIAMETER HILTI HIT-RE 500 V3 INJECTION ADHESIVE ANCHORS WITH MINIMUM 4 1/2" EMBEDMENT INTO THE FOUNDATION AT ALL EXTERIOR, LOAD-BEARING, AND SHEAR WALLS AS SHOWN ON THE PLAN.
- ALL EXTERIOR WALLS SHALL BE SHEATHED WITH MINIMUM 7/16" WOOD STRUCTURAL SHEATHING (PLYWOOD -or- OSB) WITH BLOCKING AT ALL JOINTS. FASTEN ALL PANELS WITH #8 NAILS AT 3" O.C. AT ALL EDGES AND AT 6" O.C. AT INTERMEDIATE FRAMING. AT DOUBLE TOP PLATE, FASTEN PANELS WITH A DOUBLE ROW OF #8 NAILS STAGGERED AT 3" O.C. ALL FASTENERS SHALL HAVE 1 3/8" PENETRATION INTO THE FRAMING MEMBERS.
- PROVIDE MINIMUM 1/2" GYPSUM BOARD ON BOTH SIDES OF FULL-HEIGHT INTERIOR WALLS WITH INTERMEDIATE SUPPORT AT ALL JOINTS. FASTEN ALL PANELS WITH 1 1/4" SCREWS AT 7" O.C. AT TOP AND BOTTOM PLATES AND ALL STUDS. GYPSUM SHALL BE APPLIED PERPENDICULAR TO FRAMING.
- SEE TYPICAL WALL SECTION FOR ADDITIONAL INFORMATION.

IV. WOOD TRUSSES

- ENGINEERED ROOF TRUSS SYSTEMS SHALL BE PROVIDED FOR REVIEW AND COORDINATED WITH THE ENGINEER OF RECORD. INSTALLATION SHALL BE IN ACCORDANCE WITH THE MANUFACTURER'S INSTRUCTIONS. ROOF TRUSS DRAWINGS SHALL BE SIGNED AND SEALED BY THE MANUFACTURER AND REVIEWED BY THE ENGINEER OF RECORD PRIOR TO CONSTRUCTION.
- ALL TRUSSES SHALL BE DESIGNED AND INSTALLED IN ACCORDANCE WITH BCSI 1-03 *GUIDE TO GOOD PRACTICE FOR HANDLING, INSTALLING & BRACING OF METAL PLATE CONNECTED WOOD TRUSSES.*
- THE TOP CHORD OF ALL ROOF TRUSSES SHALL BE SHEATHED WITH MINIMUM 7/16" WOOD STRUCTURAL SHEATHING (PLYWOOD -or- OSB). PROVIDE PLYWOOD EDGE CLIPS BETWEEN PANELS.
- PROVIDE PERMANENT BOTTOM CHORD TRUSS BRACING AND WEB MEMBER PLANE BRACING IN ACCORDANCE WITH BCSI-B2 *TRUSS INSTALLATION AND TEMPORARY BRACING* AND BCSI-B3 *WEB MEMBER PERMANENT BRACING* WEB REINFORCEMENT.*

ABBREVIATIONS

CONC	CONCRETE
CONT	CONTINUOUS
DBL	DOUBLE
DJ	DOUBLE JOIST
DSP	DOUBLE STUD POCKET
EA	EACH
FL PT	FLAT PLATE
FTG	FOOTING
HGR	HANGER
LVL	LAMINATED VENEER LUMBER
NTS	NOT TO SCALE
OC	ON CENTER
PT	PRESSURE TREATED
RS	RAFTER SUPPORT
SC	STUD COLUMN
SP	STUD POCKET
TJ	TRIPLE JOIST
TYP	TYPICAL
UNO	UNLESS NOTED OTHERWISE
XJ	EXTRA JOIST

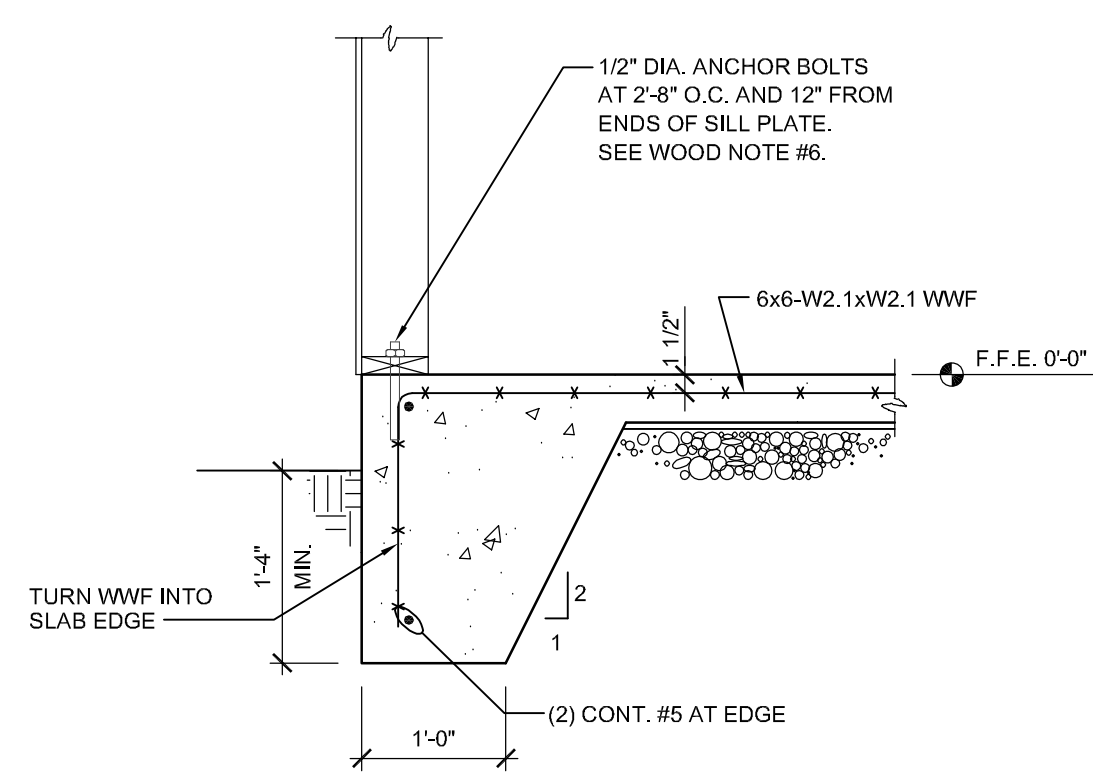

1 DETAIL - TYP. SLAB EDGE
 S4 3/4" = 1'-0"

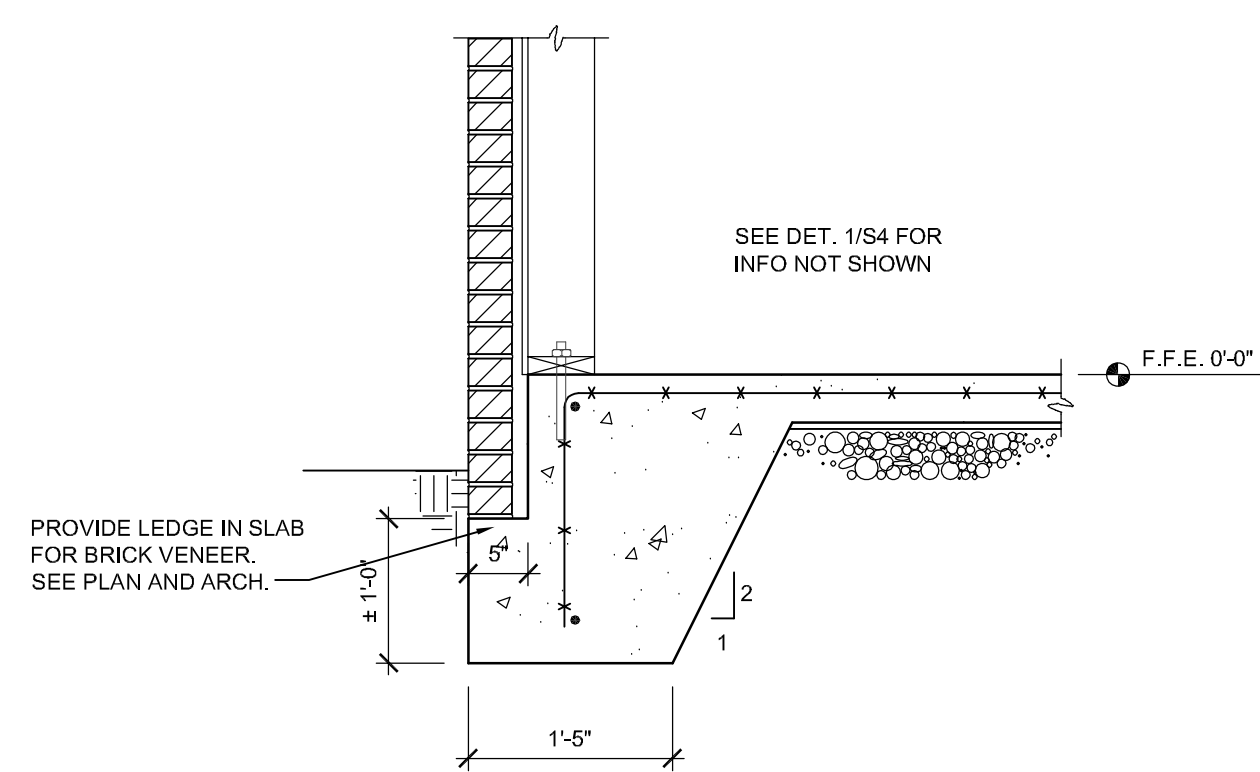

2 DETAIL - SLAB EDGE WITH BRICK LEDGE
 S4 3/4" = 1'-0"

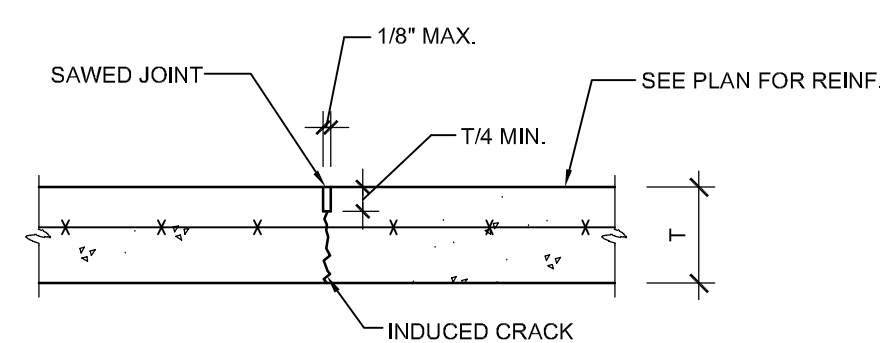

- NOTES: 1. SAW JOINTS AS SOON AS CONCRETE WILL NOT RAVEL UNDER SAW BLADE.
 2. ADD 20" LONG SMOOTH DOWELS WITH INSERTS AT ALL CONSTRUCTION JOINTS (IF USED).
 3. CONTRACTOR'S OPTION TO CUT ALTERNATING WIRES AT JOINTS FOR ADDITIONAL CRACK CONTROL.

3 DETAIL - TYP. SLAB CONTROL JOINT
 S4 1" = 1'-0"

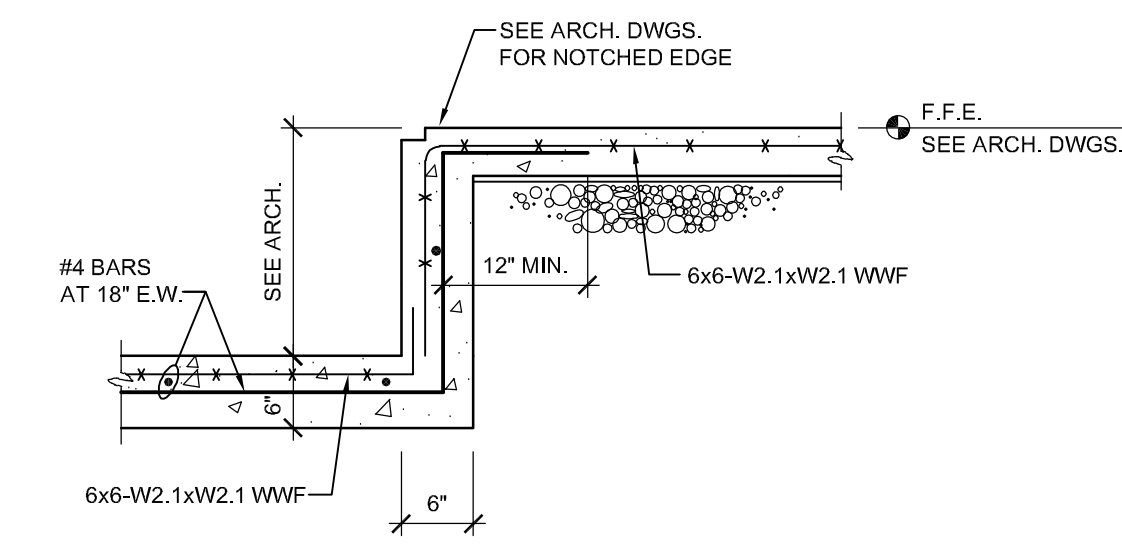

4 SECTION AT SUMP
 S4 3/4" = 1'-0"

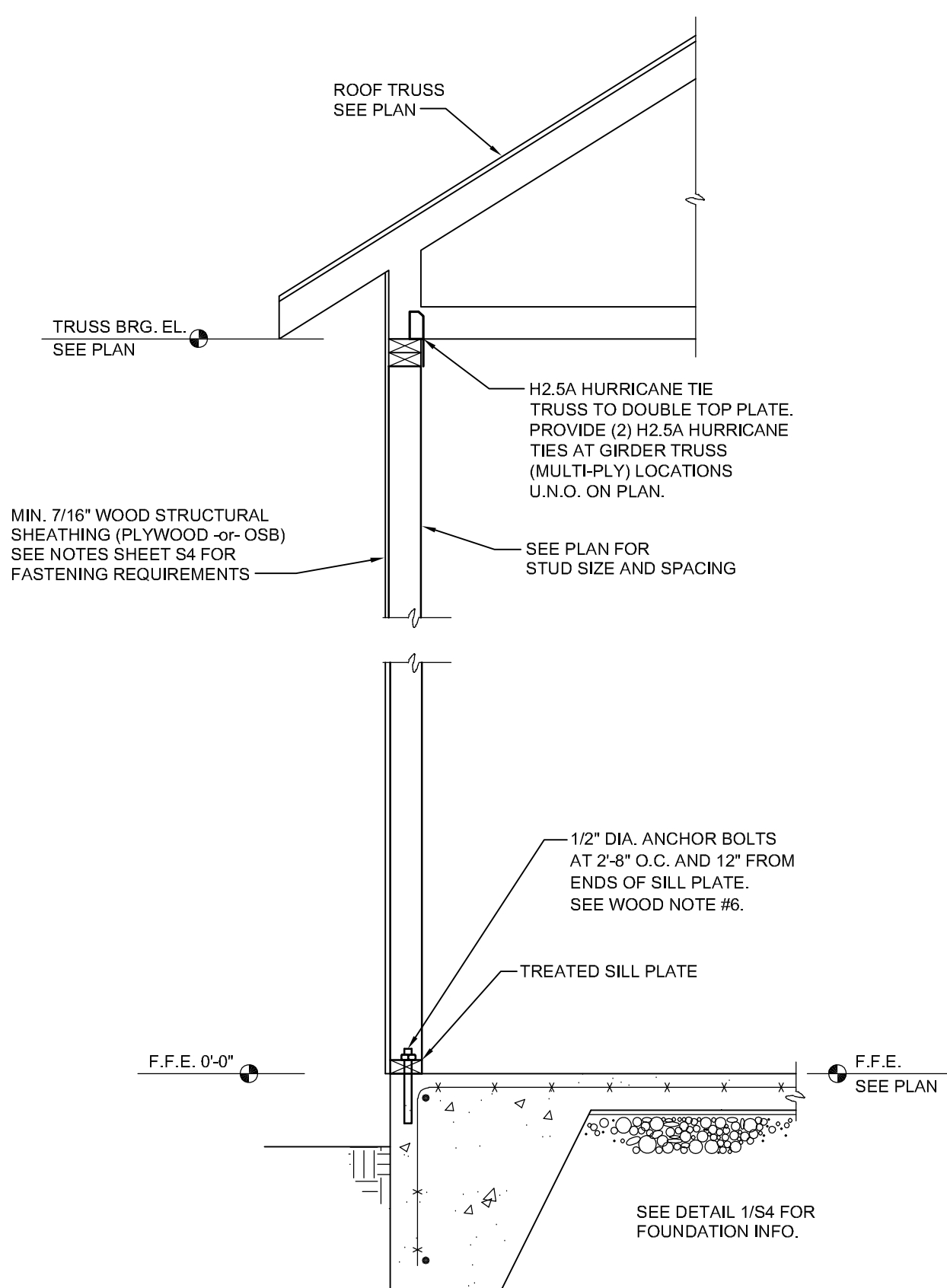

5 TYPICAL WALL SECTION
 S4 3/4" = 1'-0"

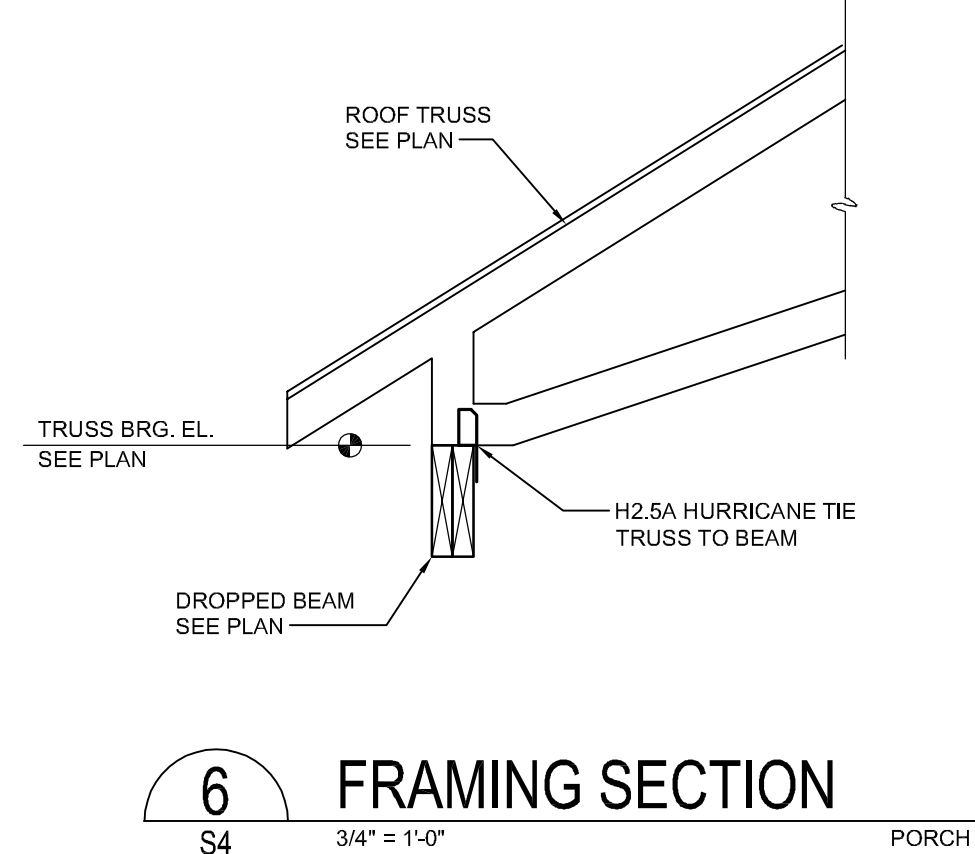

6 FRAMING SECTION
 S4 3/4" = 1'-0" PORCH



ROSS LINDEN ENGINEERS PC
 709 W. JONES STREET RALEIGH, NC 27603
 TEL: 919.812.5680 FAX: 919.812.5675
 WWW.ROSSLINDEN.COM NC LIC#56760 02/2014

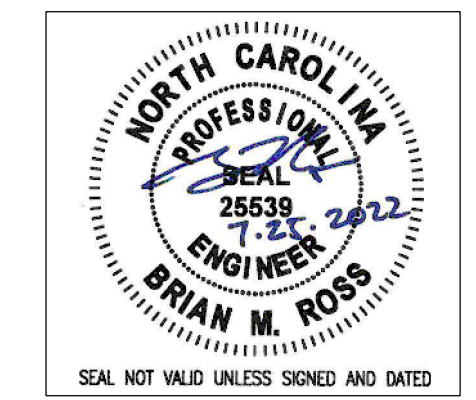

Copyright Ross Linden Engineers PC 2022. All rights reserved.

DATE	
REVISION	
NO.	

SHEET DISCRPTION

Structural Notes and Details

PROJECT #: C220702

DATE ISSUED: 07/22/2022

DRAWING BY: BR

CHECKED BY: BR/JM/BJ

WOODGROVE
 NEST COMMUNITIES
 BATHHOUSE & POOL
 HARNETT COUNTY, NC

S4

GENERAL MECHANICAL NOTES:

ADMINISTRATIVE:

- THE FOLLOWING ABBREVIATIONS SHALL APPLY TO NOTES AND PLANS:
PC - PLUMBING CONTRACTOR, EC - ELECTRICAL CONTRACTOR,
MC - MECHANICAL CONTRACTOR, GC - GENERAL CONTRACTOR,
FASC - FIRE ALARM SYSTEM CONTRACTOR.
- "PROVIDE" MEANS TO FURNISH AND INSTALL. MC SHALL ALSO INSTALL MATERIALS FURNISHED BY OTHERS AND/OR AS SHOWN ON THE PLANS OR NECESSARY FOR A COMPLETE INSTALLATION.
- THE MC SHALL BE RESPONSIBLE FOR A COMPLETE AND OPERATING SYSTEM AS DESCRIBED BY THESE PLANS AND SPECIFICATIONS.
- ALL MATERIALS AND EQUIPMENT SHALL BE DELIVERED TO THE SITE AND UNLOADED BY THE CONTRACTOR AT AN APPROVED LOCATION. THE MC SHALL PROTECT ALL MATERIALS AND EQUIPMENT FROM THEFT, VANDALISM, AND THE ELEMENTS. ALL MATERIALS AND EQUIPMENT SHALL REMAIN THE PROPERTY OF THE MC UNTIL THE PROJECT HAS BEEN COMPLETED AND TURNED OVER TO THE OWNER.
- THE MC SHALL INSTALL ALL MATERIALS AND EQUIPMENT IN ACCORDANCE WITH THE 2018 NORTH CAROLINA MECHANICAL AND BUILDING CODES AND ANY APPLICABLE LOCAL CODES. WHERE A CONFLICT EXISTS BETWEEN THE ABOVE REQUIREMENTS, THE MC SHALL OBTAIN CLARIFICATION FROM THE ENGINEER OR IN THE EVENT ANY PART OF THESE PLANS CONFLICTS WITH THE ABOVE REQUIREMENTS.
- THE MC SHALL OBTAIN AND PAY FOR ALL PERMITS, FEES, AND INSPECTIONS NECESSARY FOR THE COMPLETION OF THE WORK UNDER THIS CONTRACT.
- DO NOT SCALE THESE DRAWINGS-REFER TO ARCHITECTURAL SHEETS FOR DIMENSIONS.
- THE MC SHALL VISIT THE SITE PRIOR TO BIDDING TO BECOME FAMILIAR WITH EXISTING CONDITIONS. THE MC SHALL CONTACT THE ENGINEER TO RESOLVE ANY DISCREPANCIES BETWEEN EXISTING CONDITIONS AND THESE PLANS. THE MC SHALL COORDINATE WITH OTHER TRADES PRIOR TO THE START OF CONSTRUCTION.
- ALL MECHANICAL MATERIALS SHALL BE NEW AND FREE OF DEFECT AND LISTED AND LABELED BY UL OR AN APPROVED THIRD PARTY AGENCY. ANY MATERIALS FOUND TO BE DEFECTIVE SHALL BE REPLACED BY THE MC WITHOUT ADDITIONAL COST TO THE OWNER. WHERE A MANUFACTURER AND MODEL NUMBER IS GIVEN, THE CITED EXAMPLE IS INTENDED TO ESTABLISH A STANDARD OF QUALITY AND NOT TO LIMIT PRODUCTS TO A PARTICULAR MANUFACTURER. SUCH EXAMPLES ARE USED TO CONVEY A GENERAL STYLE, TYPE, CHARACTER, AND QUALITY OF THE PRODUCT DESIRED; PRODUCTS DETERMINED TO BE EQUAL BY THE ENGINEER WILL BE ACCEPTED.
- THESE PLANS ARE DIAGRAMMATIC. THE MC SHALL ADJUST THE LOCATIONS OF EQUIPMENT, DUCTS, REGISTERS, GRILLES, ETC. TO ACCOMMODATE PLANNED AND ENCOUNTERED INTERFERENCES. THE DRAWINGS DO NOT SHOW OFFSETS, OFFSETS, AND FITTINGS THAT MAY BE REQUIRED FOR A COMPLETE AND OPERATIONAL SYSTEM. THE MC SHALL MAKE ALLOWANCES FOR SUCH DEVIATIONS AND CONTINGENCIES IN BID TO IMPLEMENT THEM WITHOUT ADDITIONAL COST TO THE OWNER.
- ELECTRICAL CONTRACTOR SHALL BE RESPONSIBLE FOR ALL POWER CONNECTIONS TO THE MECHANICAL EQUIPMENT. MECHANICAL CONTRACTOR SHALL BE RESPONSIBLE FOR ALL CONTROL WIRING.
- IT IS THE MC'S RESPONSIBILITY TO VERIFY THAT ITEMS FURNISHED FOR THIS CONTRACT WILL FIT IN THE SPACE AVAILABLE. THE MC SHALL MAKE FIELD MEASUREMENTS AS NECESSARY TO DETERMINE SPACE REQUIREMENTS. IF THE MC MUST ALTER EQUIPMENT DUE TO SPACE CONSIDERATIONS, THE MC SHALL PROVIDE SIZES AND SHAPES THAT FIT THE INTENT OF THESE DRAWINGS AND SPECIFICATIONS.
- MC SHALL COORDINATE WITH THE ELECTRICAL CONTRACTOR REGARDING THE ELECTRICAL REQUIREMENTS OF ALL EQUIPMENT BEING PROVIDED.
- MAINTAIN CLEARANCES FOR ALL EQUIPMENT ACCORDING TO MANUFACTURER'S RECOMMENDATIONS FOR SERVICEABILITY. ALL ROOFTOP EQUIPMENT MUST BE A MINIMUM OF 10 FEET FROM ROOF EDGE.
- MC SHALL FURNISH A BOUND SET OF OPERATING AND MAINTENANCE INSTRUCTIONS FOR ALL EQUIPMENT TO THE OWNER UPON COMPLETION OF THE PROJECT. MC SHALL PROVIDE ALL DOCUMENTATION TO THE OWNER AS NECESSARY TO SUBMIT FOR FACTORY WARRANTIES.
- CONTRACTOR SHALL PROTECT ALL HVAC EQUIPMENT FROM CONSTRUCTION AND SHEET ROCK DUST DURING CONSTRUCTION. ALL FILTERS SHALL BE REPLACED WITH NEW AT THE COMPLETION OF THE PROJECT.
- ALL EQUIPMENT INSTALLED ON ROOF MUST BE WITHIN THE ROOF SCREEN. IF A ROOF PENETRATION IS REQUIRED AND THE ROOF IS UNDER WARRANTY, USE THE AUTHORIZED ROOFER. PROVIDE DOCUMENTATION.
- ALL PIPING, WIRING, CONDUIT, INSULATION, EQUIPMENT, SUPPORTS, ETC. SHALL BE SUITABLE FOR INSTALLATION IN A RETURN PLENUM AS NECESSARY. COORDINATE WITH OTHER TRADES ON LOCATIONS OF ALL PLENUMS.
- MC SHALL COORDINATE WITH THE GENERAL CONTRACTOR TO ENSURE ALL APPLICABLE CONSTRUCTION WASTE IS RECYCLED DURING THE CONSTRUCTION PHASE OF THE PROJECT.

MATERIALS:

- THE MC SHALL PROVIDE ALL DX UNITARY HEATING AND COOLING EQUIPMENT AS SCHEDULED ON THE DRAWINGS. THE MC SHALL PROVIDE FACTORY AND FIELD INSTALLED ACCESSORIES AS SCHEDULED OR AS NECESSARY FOR A COMPLETE AND OPERATIONAL HVAC SYSTEM.
- THE MC SHALL PROVIDE ALL EXHAUST AND SUPPLY FANS AS SCHEDULED. FANS SHALL BE BY GREENHECK, LOREN COOK, TWIN CITY, OR PENNBARRY. DUCTWORK IS SHOWN WITH FREE AREA DIMENSIONS. ALL DUCTWORK SHALL BE FABRICATED AND INSTALLED IN ACCORDANCE WITH SMACNA LOW PRESSURE DUCT STANDARD, 2 INCH S.P.
- EXTERNAL DUCT INSULATION AND FACTORY-INSULATED FLEXIBLE DUCT SHALL BE LEGIBLY PRINTED OR IDENTIFIED AT INTERVALS NOT GREATER THAN 36 INCHES WITH THE NAME OF THE MANUFACTURER, THE THERMAL RESISTANCE R-VALUE AT THE SPECIFIED INSTALLED THICKNESS AND THE FLAME SPREAD AND SMOKE-DEVELOPED INDEXES OF THE COMPOSITE MATERIALS. ALL DUCT INSULATION PRODUCT R-VALUES SHALL BE BASED ON INSULATION ONLY, EXCLUDING AIR FILMS, VAPOR RETARDERS OR OTHER DUCT COMPONENTS, AND SHALL BE BASED ON TESTED C-VALUES AT 75°F MEAN TEMPERATURE AT THE INSTALLED THICKNESS, IN ACCORDANCE WITH RECOGNIZED INDUSTRY PROCEDURES. THE INSTALLED THICKNESS OF DUCT INSULATION USED TO DETERMINE ITS R-VALUES SHALL BE DETERMINED AS FOLLOWS:
 - FOR DUCT BOARD, DUCT LINER AND FACTORY-MADE RIGID DUCTS NOT NORMALLY SUBJECTED TO COMPRESSION, THE NOMINAL INSULATION THICKNESS SHALL BE USED.
 - FOR DUCT WRAP, THE INSTALLED THICKNESS SHALL BE ASSUMED TO BE 75 PERCENT (25-PERCENT COMPRESSION) OF NOMINAL THICKNESS.
 - FOR FACTORY-MADE FLEXIBLE AIR DUCTS, THE INSTALLED THICKNESS SHALL BE DETERMINED BY DIVIDING THE DIFFERENCE BETWEEN THE ACTUAL OUTSIDE DIAMETER AND NOMINAL INSIDE DIAMETER BY TWO.
- ALL INSULATION CONTAINING FIBROUS MATERIALS EXPOSED TO AIRFLOW SHALL BE RATED FOR THAT EXPOSURE OR SHALL BE ENCAPSULATED. INSULATING PROPERTIES FOR ALL MATERIALS SHALL MEET OR EXCEED INDUSTRY STANDARDS. POLYSTYRENE PRODUCTS SHALL MEET ASTM C578. ALL INSULATION SHALL HAVE FORMALDEHYDE EMISSIONS NOT GREATER THAN 0.05 PPM. THE MAXIMUM FLAME SPREAD AND SMOKE DEVELOPED INDEX FOR INSULATION SHALL MEET THE REQUIREMENTS OF THE LOCAL CODES AND ORDINANCES ADOPTED BY THE JURISDICTION IN WHICH THE BUILDING IS LOCATED.
- MASTIC USED TO SEAL DUCTWORK SHALL BE LISTED AND LABELED IN ACCORDANCE WITH UL 181A-95 OR UL 181B-98. MAINTAIN AMBIENT TEMPERATURES AND CONDITIONS REQUIRED BY MANUFACTURER OF ADHESIVES, MASTICS, AND INSULATION CEMENTS. DO NOT INSTALL DUCT SEALANT WHEN TEMPERATURES ARE LESS THAN THOSE RECOMMENDED BY THE SEALANT MANUFACTURER.
- ALL ADHESIVES AND SEALANTS SHALL HAVE VOC CONTENT BELOW 20 GRAMS PER LITER AND WHICH MEET THE REQUIREMENTS OF THE MANUFACTURER OF THE PRODUCTS BEING ADHERED OR INVOLVED. ADHESIVES AND SEALANTS SHALL CONTAIN NO HEAVY METALS OR FORMALDEHYDE.
- FACTORY-MADE AIR DUCTS AND CONNECTORS SHALL COMPLY WITH UL 181-96.
- FLEXIBLE DUCT SHALL BE UL LISTED CLASS 0 OR CLASS 1, INSULATED, AND COMPLY WITH UL 181. FLEXIBLE DUCT SHALL BE FACTORY FORMED, COMPOSED OF SPIRAL WOUND CORROSION RESISTANT WIRE BONDED TO AN INNER FABRIC LINER. DUCT SHALL BE FACTORY INSULATED WITH A FOIL VAPOR BARRIER JACKET. CONNECT TO RIGID DUCT WITH SPIN-IN FITTING AND DAMPER. FLEXIBLE DUCTS AND AIR CONNECTORS SHALL NOT PASS THROUGH ANY FIRE RESISTANCE RATED ASSEMBLY.

- THE MC SHALL PROVIDE ALL DIFFUSERS GRILLES, LOUVERS, AND OTHER AIR DISTRIBUTION OUTLETS AND INLETS. LOUVERS, GRILLES, AND DIFFUSERS SHALL BE INSTALLED IN ACCORDANCE WITH THE MANUFACTURER'S INSTALLATION INSTRUCTIONS. FOR LAY-IN CEILINGS, INSTALL SUPPORT FROM THE STRUCTURE FOR EACH DIFFUSER OR DAMPER. AIR DISTRIBUTION OUTLETS AND INLETS SHALL BE BY HART & COOLEY, PRICE, METAL-AIRE, NAILOR, OR CARNES.
- AIR FILTERS SHALL BE INSTALLED IN ACCORDANCE WITH SECTION 605 OF THE 2018 MC MECHANICAL CODE.
- THE MC SHALL PROVIDE ALL REFRIGERATION PIPING. ALL PIPE AND FITTINGS SHALL BE TYPE ACR HARD COPPER TUBING WITH SWEAT FITTINGS. REFRIGERATION LINES SHALL BE RUN NEATLY. WHERE A GROUP OF LINES ARE RUN, TRAPEZE HANGERS MAY BE USED. DO NOT USE CHAIN OR WIRE HANGERS. WRAP TUBING WITH RUBBER TAPE AT EACH CLAMP OR HANGER. PROVIDE TIGHT FIT AROUND THE OUTSIDE OF THE COVERING WITH 12 GAUGE GALVANIZED STEEL SHIELDS OF A LENGTH EQUAL TO THE OUTSIDE DIAMETER OF THE INSULATION AND COVERING 3/4 OF THE CIRCUMFERENCE OF THE INSULATION. SAGS SHALL NOT BE PERMISSIBLE. HORIZONTAL LINES SHALL PITCH DOWN NOT LESS THAN 1 INCH IN 40 FEET. INSULATE WITH 1 INCH CLOSED CELL ARMAFLEX TYPE INSULATION WITH A FLAME DENSITY RATING LESS THAN 25 AND A SMOKE DENSITY RATING LESS THAN 50. ALL JOINTS AND SPICES IN INSULATION SHALL BE TAPED AND AIR TIGHT. SOLDER REFRIGERATION LINES USING 15 PERCENT SILVER SOLDER AND EVACUATE LINES TO 300 MICRONS. PROVIDE MOISTURE INDICATING SIGHT GLASS AND FILTER DRYER IN LIQUID LINE. PROVIDE OIL TRAPS AND DOUBLE RISERS IN REFRIGERANT SUCTION AND HOT GAS LINES WHERE REQUIRED TO PREVENT OIL SLUGGING AT THE COMPRESSOR AND INSURE PROPER LUBRICATION. MC SHALL BE RESPONSIBLE FOR SEALING LINE SET PENETRATIONS OF ANY RATED ASSEMBLIES IN ACCORDANCE WITH A SYSTEM LISTED IN THE UL DIRECTORY FOR THE SPECIFIC ASSEMBLY BEING PENETRATED. SEE ARCHITECTURAL PLANS FOR A LIST OF ALL UL FIRE RATED ASSEMBLIES.

METHODS:

- INSULATE DUCTWORK WITH FIBERGLASS DUCT WRAP; INSTALLED R-VALUE SHALL BE A MINIMUM R-6. COVERINGS AND LININGS, INCLUDING ADHESIVES WHEN USED, SHALL HAVE A FLAME SPREAD INDEX NOT MORE THAN 25 AND A SMOKE-DEVELOPED INDEX NOT MORE THAN 50 WHEN TESTED IN ACCORDANCE WITH ASTM E 84. ALL NEW DUCTWORK SHALL RECEIVE INSULATION ON THE OUTSIDE. INSTALL DUCT WRAP INSULATION WITH FACING OUTSIDE SO THAT TAPE FLAP OVERLAPS INSULATION AND FACING OF ADJACENT PIECE OF DUCT WRAP. INSULATION SHALL BE TIGHTLY BUTTED. FOR RECTANGULAR DUCTS, INSTALL SO INSULATION IS NOT EXCESSIVELY COMPRESSED AT DUCT CORNERS. STAPLE SEAMS APPROXIMATELY 6 INCHES ON CENTER WITH OUTWARD CLINCHING STAPLES. SEAL SEAMS WITH PRESSURE SENSITIVE TAPE MATCHING THE FACING. FOR RECTANGULAR DUCTS 24 INCHES IN WIDTH OR GREATER, SECURE DUCT WRAP TO THE BOTTOM OF THE DUCT WITH MECHANICAL FASTENERS SPACED 18 INCHES ON CENTER TO PREVENT SAGGING OF INSULATION. ADJACENT SECTIONS OF DUCT WRAP SHALL BE TIGHTLY BUTTED WITH THE 2 INCH TAPE FLAP OVERLAPPING. ALL TEARS, PUNCTURES, ETC. OF THE DUCT WRAP INSULATION SHALL BE SEALED WITH TAPE OR MASTIC TO PROVIDE A VAPOR TIGHT SYSTEM. INSULATION SHALL BE BY KNAUF INSULATION, OWENS CORNING CORP. OR CERTAINTED CORPORATION.
- VERIFY THAT DUCTS HAVE BEEN TESTED BEFORE APPLYING INSULATION MATERIALS. VERIFY THAT DUCT SURFACES ARE CLEAN, DRY AND FREE OF FOREIGN MATERIAL PRIOR TO INSULATING. DUCT COVERINGS SHALL NOT PENETRATE A WALL OR FLOOR REQUIRED TO HAVE A FIRE-RESISTANCE RATING OR REQUIRED TO BE FIRE BLOCKED.
- WHERE DUCTS ARE CONNECTED TO EXTERIOR WALL LOUVERS AND DUCT OUTLET IS SMALLER THAN LOUVER FRAME, PROVIDE BLANK-OUT PANELS SEALING LOUVER AREA AROUND DUCT. USE SAME MATERIAL AS DUCT. PAINTED BLACK ON EXTERIOR SIDE. SEAL TO LOUVER FRAME AND DUCT.
- PROVIDE DUCT ACCESS DOORS FOR INSPECTION AND CLEANING BEFORE AND AFTER FILTERS, COILS, FANS, AUTOMATIC DAMPERS, AT FIRE DAMPERS, COMBINATION FIRE AND SMOKE DAMPERS.
- CONSTRUCT T's, BENDS, AND ELBOWS WITH RADII OF NOT LESS THAN 1-1/2 TIMES THE WIDTH OF THE DUCT ON CENTERLINE. WHERE NOT POSSIBLE AND WHERE RECTANGULAR ELBOWS MUST BE USED, PROVIDE TURNING VANES.
- INCREASE DUCT SIZES GRADUALLY, NOT EXCEEDING 15 DEGREES DIVERGENCE; MAXIMUM OF 30 DEGREES DIVERGENCE UPSTREAM OF EQUIPMENT AND 45 DEGREES CONVERGENCE DOWNSTREAM.
- IT SHALL BE THE RESPONSIBILITY OF THE MC TO SUSPEND AND SUPPORT ALL EQUIPMENT, DUCTWORK, DIFFUSERS, AND OTHER MATERIALS FOLLOWING RECOGNIZED ENGINEERING PRACTICES AND USING STANDARD, COMMERCIALY ACCEPTED HANGERS AND SUSPENSION EQUIPMENT. ALL HVAC EQUIPMENT SHALL BE SECURELY MOUNTED TO THE BUILDING STRUCTURE AND SHALL NOT RELY ON CEILING OR WALL SURFACES FOR SUPPORT. THE SUPPORT ATTACHMENT SHALL SUPPORT THE WEIGHT OF THE EQUIPMENT PLUS THE WEIGHT OF THE SUPPORT ATTACHMENT ITSELF. SUPPORT FROM THE TOP CHORD OF THE ROOF JOISTS, GIRDERS, AND BEAMS. THE BOTTOM CHORD IS NOT TO BE USED FOR EQUIPMENT OR PIPING SUPPORT. HANGERS SHALL NOT BE ATTACHED TO CORRUGATED STEEL DECKING.
- DUCTS SHALL BE SUPPORTED IN ACCORDANCE WITH SMACNA AT INTERVALS NOT EXCEEDING 10 FEET. DUCTS 36 INCHES OR LARGER SHALL HAVE TRAPEZE TYPE HANGERS SUSPENDED WITH THREADED ROD. SUPPORT DUCTS FROM BAR JOISTS, GIRDERS, OR BEAMS.
- CHECK LOCATIONS OF AIR OUTLETS AND INLETS AND MAKE NECESSARY ADJUSTMENTS IN POSITION TO CONFORM WITH ARCHITECTURAL FEATURES, SYMMETRY, AND LIGHTING ARRANGEMENT. COORDINATE WITH SPRINKLER CONTRACTOR IF APPLICABLE.
- PROVIDE BALANCING DAMPERS AT POINTS ON SUPPLY WHERE BRANCHES ARE TAKEN FROM LARGER DUCTS AS REQUIRED FOR AIR BALANCING. INSTALL MINIMUM 2 DUCT WIDTHS FROM DUCT TAKE-OFF. PROVIDE BALANCING DAMPERS ON DUCT TAKE-OFFS TO DIFFUSERS, AND REGISTERS, REGARDLESS OF WHETHER DAMPERS ARE SPECIFIED AS PART OF THE DIFFUSER OR REGISTER ASSEMBLY. ADJUST AIR HANDLING AND DISTRIBUTION SYSTEMS TO PROVIDE DESIGN SUPPLY, RETURN, AND EXHAUST AIR QUANTITIES AT SITE ALTITUDE.
- MC SHALL INSTALL FIRE DAMPERS AT EACH PENETRATION OF A RATED WALL AS INDICATED ON THE DRAWINGS OR AS REQUIRED BY THE AUTHORITY HAVING JURISDICTION. FIRE DAMPERS SHALL BE UL LABELED (UL 555), CURTAIN TYPE, WITH INTEGRAL FACTORY SLEEVE AND BLADES LOCATED OUTSIDE THE AIR STREAM. INSTALLATION OF ALL FIRE DAMPERS SHALL BE IN ACCORDANCE WITH THE MANUFACTURER'S INSTALLATION INSTRUCTIONS AND SECTION 607 OF THE 2018 MC MECHANICAL CODE. PROVIDE ACCESS PANELS FOR TESTING AND SERVICE AS NECESSARY. MC SHALL PROVIDE RADIATION DAMPERS AND THERMAL BLANKETS FOR ALL PENETRATIONS OF RATED CEILING ASSEMBLIES. RADIATION DAMPERS SHALL BE UL LABELED (UL 555C) AND INSTALLED IN ACCORDANCE WITH THE MANUFACTURER'S SPECIFIC INSTALLATION INSTRUCTIONS. FIRE DAMPERS, COMBINATION FIRE/SMOKE DAMPERS, AND CEILING RADIATION DAMPERS SHALL BE BY RUSKIN, NAILOR, OR LLOYD INDUSTRIES.
- MC SHALL INSTALL PROGRAMMABLE THERMOSTATS AS SHOWN ON THE PLANS. THERMOSTAT SHALL BE MOUNTED AT 48 INCHES AFF. THERMOSTATS SHALL MEET THE REQUIREMENTS OF SECTION C403.2.4 OF THE 2018 NORTH CAROLINA ENERGY CONSERVATION CODE.
- FRESH AIR INTAKES SHALL BE INSTALLED ON ALL UNITS AS SHOWN ON DRAWINGS. MAINTAIN 10 FEET OF DISTANCE BETWEEN FRESH AIR INTAKES AND ALL EXHAUST TERMINATIONS AND PLUMBING VENT THRU ROOFS.
- MC SHALL INSTALL ALL EXHAUST FANS AND VENT TO THE BUILDING'S EXTERIOR. EC SHALL SWITCH FANS WITH LIGHTS OR ON SEPARATE SWITCH AS SHOWN.
- P-TRAPS MUST BE INSTALLED ON ALL UNITS. MC SHALL INSTALL AUXILIARY DRAIN PANS UNDER OVERHEAD AIR HANDLERS AND AUTOMATIC CUT-OFF FLOAT SWITCH FOR EACH. P-TRAPS AND CONDENSATE LINES SHALL BE 1 INCH. P-TRAPS AND CONDENSATE LINES MAY BE PVC WHERE NOT LOCATED IN PLENUMS; OTHERWISE, THEY SHALL BE TYPE M COPPER.
- INSTALL BACKDRAFT DAMPERS ON FRESH AIR AND EXHAUST DUCTS WHERE THEY PENETRATE THE THERMAL ENVELOPE PER NORTH CAROLINA ENERGY CONSERVATION CODE C402.5.5

VENTILATION CALCS	
CHEMICAL STORAGE:	
43 SQFT X 10' HIGH CEILING = 430 CU. FT @ 10 ACH = 72 CFM	
*50 CFM PROVIDED	
PUMP ROOM:	
156 SQFT X 10' HIGH CEILING = 1560 CU. FT @ 10 ACH = 260 CFM	
*175 CFM PROVIDED	

HEX PLAN NOTES	
1. EXHAUST DUCT TO TURTLE BACK ROOF VENT ON BACK SIDE OF ROOF PITCH. PROVIDE WITH INSECT SCREEN. COORDINATE EXACT LOCATION WITH G.C.	
2. LOUVERED EXHAUST GRILLE INSTALLED IN GYPSUM CEILING. TURN LOUVERED BLADES TOWARDS WALL.	
3. SUSPENDED INLINE EXHAUST FAN TO BE INSTALLED IN ATTIC. ENSURE ALL MANUFACTURER CLEARANCES ARE MAINTAINED. COORDINATE WITH G.C. TO PROVIDE ACCESS FOR MAINTENANCE.	
4. DOOR WITH WEATHER PROOF LOUVER BY G.C. LOUVER TO BE 18"X18".	
5. GRILLES AND DUCTWORK TO ALLOW FOR OUTSIDE AIR TO REDUCE NEGATIVE PRESSURE WHEN BATHROOM EXHAUST FANS ARE IN OPERATION.	
6. COMBINE BATHROOM EXHAUST TO ONE 12" EXHAUST DUCT. PROVIDE BACKDRAFT DAMPER AT EACH FAN PRIOR TO COMBINING.	
7. EXHAUST FAN TO BE WIRED FOR CONTINUOUS OPERATION.	

EXHAUST FAN SCHEDULE								
MARK	MFG / MODEL #	TYPE	ESP (in WG)	CFM	VOLT/PH	FLA	SONES	NOTES
EF-1	GREENHECK SP-A200	CEILING	0.40	179	120/1	0.43	3.0	1-3
EF-2	GREENHECK SP-A510	CEILING	0.40	364	120/1	3.30	4.0	1-3
EF-3	GREENHECK SQ-90	INLINE	0.47	362	120/1	1.20	7.4	1-6

- PROVIDE WITH PITCHED ROOF CURB & CAP FOR FLAT OR SLOPED ROOF, OR HOODED WALL WITH BACKDRAFT DAMPER CAP AS APPLICABLE.
- COVERED WITH SQUARE TO ROUND DUCT ADAPTER AS NECESSARY
- OR EQUAL BY LOREN COOK OR PENNBARRY OR TWIN CITY
- WIRED FOR CONTINUOUS OPERATION
- INTEGRAL DISCONNECT
- CORROSION RESISTANT

REGISTER & GRILLE SCHEDULE						
MARK	MFG	MODEL #	SIZE	MOUNTING	DESCRIPTION	NOTES
A	NAILOR	5145H	12X12	CEILING	ALUMINUM LOUVERED RETURN GRILLE	1
R	HART & COOLEY	RH45	12X12	SURFACE	ALUMINUM SURFACE MOUNT RETURN GRILLE	1
R2	HART & COOLEY	RH45	18X18	SURFACE	ALUMINUM SURFACE MOUNT RETURN GRILLE	1

- OR EQUAL BY PRICE, METAL-AIRE, CARNES, TITUS, HART AND COOLEY, OR NAILOR.

ELECTRIC UNIT HEATER SCHEDULE						
MARK	MFG / MODEL #	HEATER	VOLT/PH	HEAT	MOC/P	NOTES
				KW	AMPS	
UH-1-3	MARKEL/H33172RPW	4.8	240/1	4.8	30.0	1-4

- BUILT-IN THERMOSTAT.
- BUILT-IN DISCONNECT SWITCH.
- PROVIDE WITH SURFACE MOUNTING SLEEVE KIT (BATHROOMS ONLY)
- BUILT IN SUMMER FAN SWITCH (BATHROOMS ONLY)

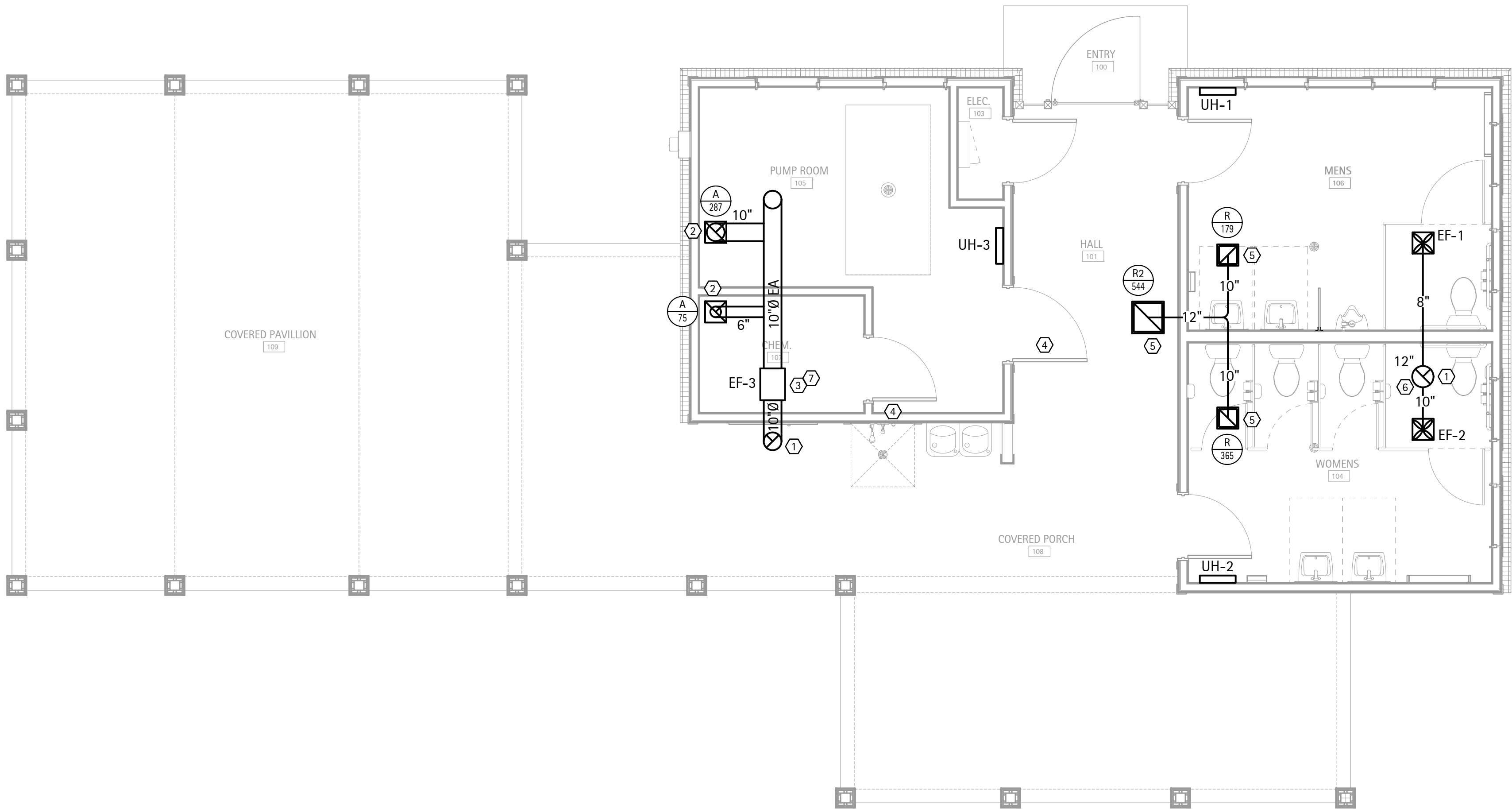

MECHANICAL SYSTEM, SERVICE SYSTEMS, AND EQUIPMENT

METHOD OF COMPLIANCE THERMAL ZONE	PRESCRIPTIVE ZONE 4A
EXTERIOR DESIGN CONDITIONS	
HEATING DESIGN DRY BULB	20.4°F
COOLING DESIGN DRY BULB	95.0°F
COOLING DESIGN WET BULB	75.5°F
INTERIOR DESIGN CONDITIONS	
HEATING DESIGN DRY BULB	50°F
COOLING DESIGN DRY BULB	75°F
COOLING RELATIVE HUMIDITY	50%
MENS BATHROOM	
HEATING LOAD:	9,364 BTU/H
WOMENS BATHROOM	
HEATING LOAD:	11,237 BTU/H
PUMP ROOM	
HEATING LOAD:	13,053 BTU/H

MECHANICAL SPACING CONDITIONING SYSTEM:	
UNITARY (DESCRIPTION OF UNITS)	AIR COOLED DX UNIT HEATERS
BOILER	N/A
TOTAL BOILER OUTPUT	N/A
CHILLER	N/A
TOTAL CHILLER CAPACITY	N/A
EQUIPMENT EFFICIENCIES:	SEE SCHEDULES
EQUIPMENT SCHEDULES WITH MOTORS (MECHANICAL SYSTEMS):	SEE SCHEDULES

DESIGNER STATEMENT:

TO THE BEST OF MY KNOWLEDGE, THE MECHANICAL DESIGN FOR THIS BUILDING COMPLIES WITH MECHANICAL AND EQUIPMENT REQUIREMENTS OF THE 2018 NORTH CAROLINA STATE BUILDING CODE AND 2018 NORTH CAROLINA ENERGY CONSERVATION CODE.



NO.	REVISION	DATE
1	PERMIT SET	07/25/22

SHEET DISCRPTION	
Mechanical Schedules & Plan	
PROJECT #:	22458
DATE ISSUED:	07/25/2022
DRAWING BY:	DBAS
CHECKED BY:	MWJ/JLH

WOODGROVE
DR HORTON
BATHHOUSE & POOL
HARNETT COUNTY, NC

GENERAL ELECTRICAL NOTES:

ADMINISTRATIVE:

- THE FOLLOWING ABBREVIATIONS SHALL APPLY TO NOTES AND PLANS:
PC - PLUMBING CONTRACTOR, EC - ELECTRICAL CONTRACTOR, MC - MECHANICAL CONTRACTOR, GC - GENERAL CONTRACTOR, FASC - FIRE ALARM SYSTEM CONTRACTOR.
- "PROVIDE" MEANS TO FURNISH AND INSTALL. THE ELECTRICAL CONTRACTOR SHALL ALSO INSTALL MATERIALS AND EQUIPMENT FURNISHED BY OTHERS AND THE GENERAL CONTRACTOR AS REQUIRED. EC SHALL PROVIDE LABOR, MATERIALS, EQUIPMENT, AND SERVICES NECESSARY AND REASONABLY INCIDENTAL TO INSURE A COMPLETE AND OPERATIONAL ELECTRICAL SYSTEM IN ACCORDANCE WITH THESE PLANS AND SPECIFICATIONS. MINOR ITEMS, ACCESSORIES, AND DEVICES REASONABLY INFERRABLE AS NECESSARY FOR THE COMPLETION AND PROPER OPERATION OF ANY ELECTRICAL SYSTEM SHALL BE PROVIDED BY THE ELECTRICAL CONTRACTOR.
- WORKMANSHIP SHALL BE IN ACCORDANCE WITH NECA 1 "STANDARD PRACTICE FOR GOOD WORKMANSHIP IN ELECTRICAL CONTRACTING." ALL MATERIALS AND EQUIPMENT SHALL BE DELIVERED TO THE SITE AND UNLOADED BY THE ELECTRICAL CONTRACTOR AT AN APPROVED LOCATION. THE ELECTRICAL CONTRACTOR SHALL PROTECT ALL MATERIALS AND EQUIPMENT FROM BREAKAGE, THEFT, AND THE ELEMENTS. ALL MATERIALS AND EQUIPMENT SHALL REMAIN THE PROPERTY OF THE ELECTRICAL CONTRACTOR UNTIL THE PROJECT HAS BEEN COMPLETED AND TURNED OVER TO THE OWNER.
- THE ELECTRICAL CONTRACTOR SHALL OBTAIN AND PAY FOR ALL PERMITS, FEES, AND INSPECTIONS NECESSARY FOR THE COMPLETION OF THE WORK UNDER THIS CONTRACT.
- DO NOT SCALE THESE DRAWINGS-REFER TO ARCHITECTURAL SHEETS FOR DIMENSIONS.
- TRADE NAMES AND MANUFACTURERS ARE SPECIFIED TO ESTABLISH A QUALITY STANDARD. SUBSTITUTIONS SHALL BE PERMITTED IF APPROVED BY THE ENGINEER PRIOR TO INSTALLATION. ALL LISTED MODEL NUMBERS SHALL BE VERIFIED WITH THE MANUFACTURER FOR PROPER APPLICATION OF EQUIPMENT.
- THE ELECTRICAL CONTRACTOR SHALL VISIT THE SITE PRIOR TO BIDDING TO BECOME FAMILIAR WITH EXISTING CONDITIONS. THE ELECTRICAL CONTRACTOR SHALL CONTACT THE ENGINEER TO RESOLVE ANY DISCREPANCIES BETWEEN EXISTING CONDITIONS AND THESE PLANS. THE ELECTRICAL CONTRACTOR SHALL COORDINATE WITH OTHER TRADES PRIOR TO THE START OF CONSTRUCTION.
- GROUNDING AND BONDING SHALL BE PER NEC ARTICLE 250. THE RACEWAY SYSTEM SHALL NOT BE RELIED UPON FOR GROUNDING CONTINUITY. A GREEN EQUIPMENT GROUNDING CONDUCTOR, SIZED PER NEC TABLE 250-122, SHALL BE RUN IN ALL POWER RACEWAYS. FOR NON-ISOLATED GROUND CIRCUITS PROVIDE ONE EQUIPMENT GROUNDING CONDUCTOR PER CONDUIT RUN. FOR ISOLATED GROUND CIRCUITS, PROVIDE ONE NEUTRAL AND ONE ISOLATED GROUND WIRE FOR EACH CIRCUIT. IN ADDITION, PROVIDE ONE EQUIPMENT GROUNDING CONDUCTOR PER CONDUIT RUN. MAIN BONDING JUMPERS AND SYSTEM BONDING JUMPERS SHALL BE INSTALLED IN ACCORDANCE WITH 250.28 OF THE NEC. FOR BUILDINGS OR STRUCTURES SUPPLIED BY FEEDERS OR BRANCH CIRCUITS, GROUNDING AND BONDING SHALL BE IN ACCORDANCE WITH 250.32. SEPARATELY DERIVED AC SYSTEMS SHALL BE GROUNDED IN ACCORDANCE WITH 250.30. RESISTANCE TO GROUND SHALL NOT EXCEED 25 OHMS; ADDITIONAL GROUNDING ELECTRODES SHALL BE INSTALLED PER 250.56 AS NECESSARY.
- THE ELECTRICAL CONTRACTOR SHALL ALSO COORDINATE WITH THE GENERAL CONTRACTOR REGARDING THE BONDING OF THE FOOTING REBAR, SO THAT IT WILL BE IN PLACE AND READY AT TIME OF FOOTING INSPECTION.
- ALL MATERIALS AND EQUIPMENT SHALL COMPLY WITH THE UNDERWRITERS' LABORATORIES, INC. STANDARDS OR HAVE UL APPROVAL, OR BE LISTED UNDER THE UL LISTINGS WHERE SUCH APPROVAL HAS BEEN ESTABLISHED FOR THE TYPE OF DEVICE IN QUESTION.
- CONDUCTORS, FUSES, CIRCUIT BREAKERS, AND DISCONNECT SWITCHES SHOWN ON THESE PLANS HAVE BEEN SIZED FOR THE SPECIFIED EQUIPMENT. BEFORE ORDERING ELECTRICAL EQUIPMENT, THE ELECTRICAL CONTRACTOR SHALL COORDINATE WITH OTHER CONTRACTORS ON THE SITE AND NOTIFY THE ENGINEER OF ANY DISCREPANCIES SHOULD CONDUIT, CIRCUIT BREAKER, OR FUSE SIZES REQUIRE CHANGE.
- THE ELECTRICAL CONTRACTOR SHALL COORDINATE WITH THE GENERAL CONTRACTOR TO ENSURE THE FOLLOWING MATERIALS ARE RECYCLED DURING THE CONSTRUCTION PHASE OF THE PROJECT: LIGHT FIXTURES, INCLUDING PROPER DISPOSAL OF BALLASTS, FLUORESCENT LIGHT BULBS, AND TRANSFORMERS, WIRING AND ELECTRICAL EQUIPMENT, AND INSULATION. WASTE MATERIALS CONTAINING LEAD, ASBESTOS, PCBs (FLUORESCENT LAMP BALLASTS), OR OTHER HARMFUL SUBSTANCES SHALL BE HANDLED AND DISPOSED OF IN ACCORDANCE WITH FEDERAL AND STATE LAWS AND REQUIREMENTS CONCERNING HAZARDOUS WASTE.
- ALL WORK SHALL CONFORM TO 2020 NATIONAL ELECTRICAL CODE, 2018 STATE BUILDING CODE, AND ALL APPLICABLE LOCAL CODES.

MATERIALS:

- THE ELECTRICAL CONTRACTOR SHALL PROVIDE ALL NECESSARY DISCONNECTS, SWITCHES, RECEPTACLES, TERMINALS, ETC. UNDER THE ELECTRICAL BID AND SHALL INCLUDE ALL NECESSARY CIRCUITS AND CONNECTIONS TO THE EQUIPMENT PROVIDED BY ALL SUPPLIERS, UNLESS NOTED OTHERWISE BY OTHER DISCIPLINES.
- ELECTRICAL CONTRACTOR SHALL PROVIDE ALL SERVICE ENTRANCE EQUIPMENT, SUB PANELS, AND OTHER ELECTRICAL DISTRIBUTION EQUIPMENT AS NECESSARY FOR A COMPLETE INSTALLATION. ELECTRICAL CONTRACTOR SHALL COORDINATE WITH UTILITY REGARDING SERVICE AND METERING DETAILS. PRIOR TO ORDERING EQUIPMENT, THE ELECTRICAL CONTRACTOR SHALL OBTAIN THE AVAILABLE FAULT CURRENT OR TRANSFORMER SIZE AND IMPEDANCE FROM THE UTILITY AND CONTACT THE ENGINEER IF THE VALUE EXCEEDS THE EQUIPMENT SPECIFIED. PANEL BOARDS AND SWITCH BOARDS SHALL BE SQUARE D, CUTLER-HAMMER, SIEMENS, OR GE. BUSES SHALL BE COPPER UNLESS OTHERWISE APPROVED BY THE ENGINEER. RECESSED PANEL BOARDS SHALL BE INSTALLED FLUSH WITH THE WALL FINISH. METER BASES SHALL COMPLY WITH THE UTILITY'S SPECIFICATIONS AND SHALL BE MOUNTED AT A HEIGHT APPROVED BY THE UTILITY. ALL EQUIPMENT IDENTIFIED FOR SERVICE ENTRANCE USE SHALL BE SO LABELED AND UL LISTED FOR SUCH USE. ELECTRICAL CONTRACTOR SHALL INSTALL ALL ELECTRICAL EQUIPMENT WITH CLEARANCES PER NEC 110.26.
- ELECTRICIAN SHALL PERMANENTLY LABEL EQUIPMENT PER NEC 110.24. ENCLOSED SAFETY SWITCHES SHALL BE HEAVY DUTY TYPE BY SQUARE D, EATON, OR GE. ENCLOSED SWITCHES SHALL HAVE A HANDLE LOCKABLE IN THE OFF POSITION AND SHALL HAVE A HANDLE INTERLOCKED TO PREVENT OPENING THE PANEL IN THE ON POSITION. ENCLOSED SWITCHES OF THE FUSIBLE TYPE SHALL BE FUSED IN ACCORDANCE WITH NAMEPLATE DATA WITH DUAL ELEMENT TYPE FUSES BY BUSSMAN, LITTELFUSE, OR MERSEN.
- OCCUPANCY SENSORS SHALL BE BY WATTSTOPPER, LUTRON, LEVITON, SENSOR SWITCH, HUBBELL, OR APPROVED EQUAL. CIRCUIT BREAKERS SHALL BE MOLDED-CASE, THERMAL MAGNETIC TYPE WITH QUICK-MAKE, QUICK-BREAK MECHANISM, COMMON TRIP ON MULTI-POLE BREAKERS, AND UL LISTED FOR BOTH COPPER AND ALUMINUM CONDUCTORS. CIRCUIT BREAKERS IN PANELS SHALL BE SERIES RATED WITH THE MAIN BREAKER, FULLY RATED FOR THE SYSTEM, OR SERIES RATED WITH THE BREAKER FEEDING THE PANEL FROM THE FACTORY.
- ALL WIRE, CONNECTORS, TERMINALS, AND LUGS SHALL BE PROVIDED BY THE ELECTRICAL CONTRACTOR. WHERE CONDUCTORS ARE RUN IN PARALLEL, LUGS SHALL BE LISTED FOR PARALLEL CONDUCTORS. PUSH WIRE CONNECTORS ARE NOT ALLOWED FOR BUILDING WIRE. PUSH CONNECTORS ARE ONLY ALLOWED, WHEN APPROVED, AS PART OF MANUFACTURED LISTED PRODUCTS. ALL WIRE SHALL BE INSTALLED IN CONDUIT UNLESS SPECIFICALLY NOTED OTHERWISE.
- THE INSULATION TYPE FOR INTERIOR WIRING SHALL BE DUAL RATED THIN/THIN OR XHHW; ALL WIRING INSTALLED BELOW GRADE OR IN

MOIST OR WET LOCATIONS SHALL HAVE TYPE THHN OR XHHW INSULATION. INSULATION VOLTAGE RATING SHALL BE 600 VOLTS AND A MINIMUM TEMPERATURE RATING OF 75°C. CONDUCTORS SHALL BE SOLID OR STRANDED COPPER FOR #10 AWG AND #12 AWG, AND STRANDED COPPER FOR #8 AWG AND LARGER SIZES. ALL WIRING AND CABLE SHALL BE UL LISTED. ALL TERMINATIONS AND DEVICES SHALL BE RATED FOR USE WITH 75°C CONDUCTORS. FINAL CONNECTIONS TO ALL MOTORS AND EQUIPMENT SUBJECT TO VIBRATION OR EXCESSIVE MECHANICAL STRESS SHALL BE MADE WITH STRANDED COPPER CONDUCTORS. CONDUCTORS SHALL BE BY CERRO WIRE, INC, INDUSTRIAL WIRE & CABLE, INC, OR SOUTHWIRE COMPANY.

8. JOINTS IN SOLID CONDUCTORS SHALL BE SPliced USING IDEAL "WIRE NUTS"; 3M "SCOTCH LOCK", OR THE "PIGGY" CONNECTORS IN JUNCTION BOXES, OUTLET BOXES, AND LIGHTING FIXTURES. JOINTS IN STRANDED CONDUCTORS SHALL BE SPliced BY APPROVED MECHANICAL CONNECTORS AND GUM RUBBER TAPE OR FRICTION TAPE. SOLDERLESS MECHANICAL CONNECTORS FOR SPICES AND TAPS, PROVIDED WITH UL APPROVED INSULATING COVERS, MAY BE USED INSTEAD OF MECHANICAL CONNECTORS PLUS TAPE. IN ALL CASES, CONDUCTORS SHALL BE CONTINUOUS FROM OUTLET TO OUTLET AND NO SPlicing SHALL BE MADE EXCEPT WITHIN OUTLET OR JUNCTION BOXES, TROUGHS, OR GUTTERS. WHERE CONCENTRIC, ECCENTRIC, OR OVERSIZED KNOCKOUTS ARE ENCOUNTERED, A GROUNDING TYPE INSULATED BUSHING SHALL BE PROVIDED.

9. ALL LUMINAIRES SHALL BE LISTED. LUMINAIRES IN WET OR DAMP LOCATIONS SHALL BE MARKED AS SUITABLE FOR THE RESPECTIVE USE. EMERGENCY LIGHTING SHALL BE INSTALLED AS SHOWN. FINAL LOCATIONS OF ALL EXIT AND EMERGENCY LIGHTS SHALL BE VERIFIED WITH THE BUILDING INSPECTOR PRIOR TO INSTALLATION. ALL FLUORESCENT FIXTURES SHALL HAVE ELECTRONIC BALLASTS MEETING ANSI C82.11 FOR ELECTRONIC BALLAST PERFORMANCE. ALL BALLASTS SHALL BE UL LISTED AND MEET FEDERAL AND STATE EFFICIENCY REQUIREMENTS.

10. ALL CONDUIT, FITTINGS, COUPLINGS, AND SUPPORTS SHALL BE PROVIDED BY THE ELECTRICAL CONTRACTOR. CONDUIT FITTINGS AND COUPLINGS SHALL BE BY APPLETON, RACO, OR O-2/GEDNEY. COUPLINGS SHALL BE THREADED, SET-SCREW, OR COMPRESSION TYPE. INDENTER OR CRIMP TYPE ARE NOT PERMITTED. CONDUIT FITTINGS AT ALL ELECTRICAL BOXES INCLUDING PULL, JUNCTION, AND OUTLET BOXES, SHALL HAVE INSULATED THROATS TO PREVENT INSULATION SCORING. DIE CAST FITTINGS ARE NOT PERMITTED.

11. EMT SHALL BE MANUFACTURED IN ACCORDANCE WITH AMERICAN NATIONAL STANDARDS INSTITUTE-AMERICAN NATIONAL STANDARD FOR STEEL ELECTRICAL METALLIC TUBING (EMT), ANSI C80.3 AND UL 797. RIGID METAL CONDUIT SHALL BE MANUFACTURED IN ACCORDANCE WITH ANSI-AMERICAN NATIONAL STANDARD FOR ELECTRICAL RIGID STEEL CONDUIT (ERSC), ANSI C80.1 AND UL 6. INTERMEDIATE METAL CONDUIT SHALL BE MANUFACTURED IN ACCORDANCE WITH ANSI-AMERICAN NATIONAL STANDARD FOR INTERMEDIATE METAL CONDUIT ANSI C80.6 AND UL 1242.

12. METAL CONDUIT SHALL BE BY ALIRED TUBING & CONDUIT, BECK MANUFACTURING, INC, OR WHEATLAND TUBE COMPANY. FLEXIBLE METAL CONDUIT, LIQUID-TIGHT FLEXIBLE METAL CONDUIT, AND NONMETALLIC CONDUIT SHALL BE BY AFC CABLE SYSTEMS, INC, ELECTRI-FLEX COMPANY, OR INTERNATIONAL METAL HOSE.

METHODS:

- EC SHALL REVIEW THE MECHANICAL PLANS TO ESTABLISH POINTS OF CONNECTION AND THE EXTENT OF THE ELECTRICAL WORK TO BE PROVIDED IN THE CONTRACT.
- ALL CIRCUIT BREAKERS FEEDING HVAC EQUIPMENT SHALL BE HACR BREAKERS. ALL BRANCH CIRCUIT CONDUCTORS SHALL BE MINIMUM #12 AWG IN 3/4 in CONDUIT. EACH MULTI-WIRE BRANCH CIRCUIT SHALL BE PROVIDED WITH A MEANS TO SIMULTANEOUSLY DISCONNECT ALL UNGROUNDED CONDUCTORS AT THE SOURCE PER NEC 210.4(B). GROUP ALL CONDUCTORS OF EACH MULTI-WIRE BRANCH CIRCUIT PER 210.4(D) WITH WIRE TIES OR SIMILAR MEANS. DO NOT EXCEED THREE HOMERUNS PER CONDUIT. DO NOT INSTALL ISOLATED GROUND AND NON-ISOLATED GROUND CIRCUITS IN THE SAME CONDUIT. INSTALL CONDUCTORS OF DIFFERENT VOLTAGES IN SEPARATE CONDUITS.
- COLOR CODE CONDUCTORS PER NEC. FEEDERS SHALL BE IDENTIFIED IN ACCORDANCE WITH NEC 215.12. USE BLACK AND RED FOR PHASES A AND B RESPECTIVELY OR ON 240VOLT SINGLE-PHASE SYSTEMS AND WHITE FOR THE NEUTRAL. THIS IDENTIFICATION SHALL BE MADE AT EACH POINT WHERE A CONNECTION IS MADE. COLORS SHALL BE FACTORY APPLIED FOR CONDUCTORS #6 AWG AND SMALLER. ALL EQUIPMENT GROUNDING CONDUCTORS SHALL BE GREEN IN COLOR AND MINIMUM #12 AWG. THE EC SHALL PROVIDE PLENUM RATED CABLE FOR ANY ELECTRICAL TELEPHONE, COMMUNICATION, OR OTHER CABLE THAT ENTERS CEILING RETURN PLENUMS.
- ALL LIGHT FIXTURES SHALL BE SUPPORTED INDEPENDENTLY OF THE SUSPENDED CEILING. COORDINATE LIGHTING LAYOUT WITH CEILING GRID, MECHANICAL EQUIPMENT, DUCTWORK AND SPRINKLER HEADS AS NECESSARY. SEE REFLECTED CEILING PLAN FOR DETAILS. FLUORESCENT FIXTURES UTILIZING DOUBLE-ENDED LAMPS MUST HAVE DISCONNECTING MEANS COMPLYING WITH NEC 410.130(G).
- MOUNT LIGHT SWITCHES AT 48 in AFF. MULTIPLE SWITCHES AT SAME LOCATION SHALL BE UNDER ONE WALL PLATE. VERIFY WALL PLATE COLOR AND MATERIAL WITH THE ARCHITECT/OWNER. INSTALL SWITCHES WITH OFF POSITION DOWN. ALL SWITCHES SHALL BE HEAVY DUTY, IVORY PLASTIC WITH TOGGLE HANDLE, RATED 120-277V AC, AND COMPLYING WITH NEMA WD 6 AND WD 1. SWITCHES SHALL BE BY COPPER WIRING DEVICES, LEVITON MANUFACTURING, PASS & SEYMOUR, OR HUBBELL. PROVIDE BOX DEVICE PARTITION/DIVIDERS FOR MULTI-GANG BOXES FOR COMPLIANCE WITH NEC 404.8(B).
- ELECTRICAL CONTRACTOR SHALL PROVIDE FIRE-STOPPING AT ALL ELECTRICAL PENETRATIONS OF RATED FLOORS AND WALLS TO PRESERVE OR RESTORE THE FIRE-RESISTANCE RATING. SEAL PENETRATIONS USING A UL LISTED SYSTEM FOUND IN THE UL DIRECTORY SPECIFIC TO THE UL LISTING OF THE ASSEMBLY BEING PENETRATED. SEE ARCHITECTURAL PLANS FOR UL RATED ASSEMBLIES SPECIFIC TO THIS PROJECT.
- ELECTRICAL CONTRACTOR SHALL PROVIDE GFCI RECEPTACLES IN KITCHENS, RESTROOMS, OUTDOORS, AND IN SHOP AREAS AS REQUIRED BY NEC. REFRIGERATORS AND WATER COOLERS MUST HAVE A DEDICATED GFCI BREAKER. EACH OUTDOOR HVAC UNIT MUST HAVE A GFCI RECEPTACLE WITHIN 25 FEET FOR SERVICING. GFCI RECEPTACLES SHALL CONFORM TO UL 943 CLASS A AND UL 498 STANDARDS. RECEPTACLES SHALL BE BY COPPER WIRING DEVICES, LEVITON MANUFACTURING, PASS & SEYMOUR, OR HUBBELL. ALL RECEPTACLES PER 110.16 OF NEC.
- LOCATIONS AND HEIGHTS OF ALL WALL-MOUNTED DEVICES SHALL BE COORDINATED WITH THE ARCHITECT PRIOR TO INSTALLATION.
- CONCEAL ALL CONDUIT EXCEPT IN MECHANICAL ROOMS OR UNFINISHED AREAS AS NOTED. USE EMT CONDUIT FOR ALL BRANCH CIRCUITS AND FEEDERS INSIDE THE BUILDING. TYPE MC CABLE AND TYPE AC CABLE MAY BE INSTALLED WITHIN WALLS IF ALL NEUTRAL WIRES, ISOLATED GROUND WIRES, AND EQUIPMENT GROUNDING WIRES AS LISTED ABOVE ARE CONTAINED IN THE CABLE. FLEXIBLE CONNECTIONS TO MOTORS AND OTHER EQUIPMENT SHALL BE MADE USING WEATHERPROOF FLEXIBLE CONDUIT. FOR LAY-IN LIGHT FIXTURES, USE MAXIMUM OF SIX (6) FEET OF FLEXIBLE MC CABLE (OR THE FLEXIBLE CONDUIT PROVIDED BY THE FIXTURE MANUFACTURER). SCHEDULE 40 PVC CONDUIT MAY BE USED FOR THE SECONDARY UNDERGROUND SERVICE, UNDERGROUND TELEPHONE SERVICE, AND BRANCH AND FEEDER CIRCUITS UNDER SLAB OR EXTERIOR TO THE BUILDING. EXPOSED EXTERIOR CONDUIT SHALL BE SCHEDULE 80 PVC. ALL UNDERGROUND RACEWAYS SHALL BE IDENTIFIED WITH UNDERGROUND LINE MARKING TAPE 6-8 in BELOW GRADE DIRECTLY ABOVE THE RACEWAY. PROVIDE PULL WIRE IN EMPTY CONDUITS. UPSIZE CONDUIT FROM MINIMUM SIZE AS NECESSARY FOR LONGER PULLS. UNDERGROUND RACEWAYS THAT STUB INTO THE BOTTOM OF SWITCHBOARDS, OUTDOOR TRANSFORMERS, GENERATORS, ETC., SHALL RISE AT LEAST 2 in ABOVE THE FINISHED SLAB TO PREVENT WATER FROM DRAINING INTO THE RACEWAYS. RACEWAYS THAT PENETRATE EXTERIOR WALLS OR INTERIOR PARTITIONS SEPARATING

SPACES THAT WILL BE AT SIGNIFICANTLY DIFFERENT TEMPERATURES SHALL BE SEALED IN ACCORDANCE WITH 300.5(E), 300.7(A), AND 300.50(E) OF THE NEC. ROUTE CONDUIT IN AND UNDER SLAB FROM POINT-TO-POINT. ROUTE EXPOSED CONDUIT AND CONDUIT INSTALLED ABOVE ACCESSIBLE CEILINGS PARALLEL AND PERPENDICULAR TO WALLS. COMPLETELY AND THOROUGHLY SWAB ALL RACEWAYS BEFORE INSTALLING WIRE. PULL ALL CONDUCTORS INTO EACH RACEWAY AT ONE TIME. USE A SUITABLE WIRE PULLING LUBRICANT FOR BUILDING WIRE #4 AWG AND LARGER.

10. CABLES, RACEWAYS, OR BOXES, INSTALLED IN EXPOSED OR CONCEALED LOCATIONS UNDER METAL-CORRUGATED SHEET ROOF DECKING, SHALL BE INSTALLED AND SUPPORTED SO THERE IS NOT LESS THAN 1-1/2" MEASURED FROM THE LOWEST SURFACE OF THE ROOF DECKING TO THE TOP OF THE CABLE, RACEWAY, OR BOX. A CABLE, RACEWAY, OR BOX SHALL NOT BE INSTALLED IN CONCEALED LOCATIONS IN METAL-CORRUGATED SHEET DECKING-TYPE ROOF. SEE NEC 300.4(E).

11. THE ELECTRICAL CONTRACTOR SHALL PROVIDE ALL OUTLET, JUNCTION, PULL BOXES, FITTINGS, AND SUPPORTS. ALL OUTLET AND JUNCTION BOXES SHALL BE GALVANIZED STEEL TYPE BY APPLETON, STEEL CITY, OR RACO. EXTERIOR BOXES SHALL BE TYPE FS. VAPORITITE BOXES SHALL BE TYPE OS. WHERE SURFACE MOUNTED BOXES ARE USED, THOSE BOXES AND THEIR FACEPLATES SHALL HAVE ROUNDED CORNERS. BOXES INSTALLED IN FLOORS SHALL BE RATED FOR THE APPLICATION. MOUNT JUNCTION AND OUTLET BOXES FLUSH WITH FINISH SURFACES UNLESS OTHERWISE NOTED. WHERE MOUNTING HEIGHTS ARE GIVEN, THEY SHALL BE MEASURED FROM THE FINISHED FLOOR TO THE CENTER OF THE BOX. ALL BOXES SHALL BE SIZED PER NEC ARTICLE 314. ALL OUTLET AND JUNCTION BOXES SHALL HAVE A COVER PLATE, PROVIDED BY THE ELECTRICAL CONTRACTOR. OUTLET BOXES IN RATED WALLS SHALL BE INSTALLED IN ACCORDANCE WITH NORTH CAROLINA BUILDING CODE 712.3.2 (MAXIMUM BOX SIZE IS 16 SQUARE IN AND MAXIMUM OF SIX (6) BOXES PER 100 SQUARE FEET). INSTALL OUTLET BOXES IN RATED WALLS SUCH THAT OPENINGS OCCUR IN ONE SIDE ONLY WITHIN ANY GIVEN STUD SPACE. ALL CLEARANCES BETWEEN THE OUTLET BOX AND THE GYPSUM BOARD SHALL BE FILLED WITH JOINT COMPOUND OR OTHER APPROVED FIRE STOP MATERIAL. FLUSH MOUNTED JUNCTION BOXES IN ADJACENT ROOMS SHALL NOT BE MOUNTED BACK-TO-BACK. SURFACE MOUNTED FIXTURES SHALL BE FED THROUGH FLUSH MOUNTED 4X4 OCTAGONAL OR SQUARE BOXES.

12. ALL CONDUIT, BOXES, AND ELECTRICAL EQUIPMENT SHALL BE FIRMLY AND SECURELY FASTENED TO OR SUPPORTED FROM THE BUILDING STRUCTURAL MEMBERS OR EMBEDDED IN CONCRETE OR MASONRY. ELECTRICAL SUPPORTS SHALL NOT BE ATTACHED TO DUCTWORK, PIPING, OR THEIR SUPPORTS. HANGERS SHALL BE CATALOG ITEMS COMPATIBLE WITH AND SUITABLE FOR THE INTENDED USE. FOR METAL ROOF DECK INSTALLATIONS, 1 in EMT CONDUIT MAXIMUM AND 4 in JUNCTION BOXES MAXIMUM MAY BE SUPPORTED BY DECKING. THE SUSPENDED CEILING SYSTEM SHALL NOT BE USED FOR THE SUPPORT OF ELECTRICAL RACEWAY SYSTEMS OR SUPPORT OF COMMUNICATIONS OR DATA SYSTEMS WIRING. CONTRACTOR SHALL COMPLY WITH 1613 OF THE NORTH CAROLINA GENERAL CONSTRUCTION BUILDING CODE.

13. WHERE CONDUCTORS ARE RUN IN PARALLEL, THE EC SHALL COMPLY WITH NEC 310.4.

14. ISOLATED-GROUND TYPE RECEPTACLES SHALL BE INSTALLED IN ACCORDANCE WITH 250.146(D). ISOLATED GROUND RECEPTACLES SHALL BE ORANGE IN COLOR.

15. IN ASSEMBLY AREAS EXCEEDING 100 PERSONS OCCUPANCY, WIRING METHODS SHALL COMPLY WITH NEC 518.

16. PROVIDE AN UNDERGROUND PVC CONDUIT SYSTEM FOR TELEPHONE SERVICE WITH PULL WIRES. ELECTRICAL CONTRACTOR SHALL COORDINATE WITH TELEPHONE UTILITY REGARDING ADDITIONAL FACILITIES REQUIRED FOR THE SERVICE INSTALLATION.

17. INSTALL ONE (1) 3/4 in FIRE RETARDANT TREATED PLYWOOD BACKBOARD WHERE INDICATED ON THE DRAWINGS FOR THE USE BY THE TELEPHONE SYSTEM. PROVIDE A 120 VOLT RECEPTACLE ADJACENT TO THE TELEPHONE BOARD. GROUND ALL TELEPHONE AND COMMUNICATIONS CIRCUITS PER NEC 800.

18. ALL TELEPHONE AND COMMUNICATIONS OUTLETS AND RACEWAYS ARE ROUGH-INS ONLY. EACH TELEPHONE AND COMMUNICATIONS OUTLET SHALL BE A 4 in SQUARE BY 2-1/8 in DEEP BOX WITH 3/4 in KNOCK-OUTS AND A 3/4 in CONDUIT STUBBED FROM THE OUTLET BOX TO ABOVE THE CEILING. PROVIDE A NON-METALLIC INSULATING BUSHING ON ALL CONDUITS STUBBED ABOVE THE CEILING. PROVIDE A BLANK COVER PLATE ON ALL OUTLET BOXES.

19. ELECTRICAL CONTRACTOR SHALL INSTALL DISCONNECT SWITCHES IN SIGHT OF ALL HARDWIRED EQUIPMENT AND APPLIANCES OR PROVIDE BREAKERS CAPABLE OF BEING LOCKED IN THE OPEN POSITION PER NEC 422.31. FOR MOTOR DRIVEN APPLIANCES, PROVIDE A DISCONNECTING MEANS PER NEC 422.31 AND 430 PART IX WHERE AN INDIVIDUAL DISCONNECT SWITCH, CIRCUIT BREAKER, STARTER, ETC. IS SHOWN ON THE PLANS ADJACENT TO ITS LOAD AND NOT LOCATED ON A WALL. PROVIDE NECESSARY MATERIALS AND LABOR TO SUPPORT THE DEVICE. ELECTRICAL CONTRACTOR SHALL FIELD IDENTIFY ALL SWITCH BOARD, PANEL BOARDS, CONTROL PANELS, METER SOCKETS, ETC. TO WARN QUALIFIED PERSONS OF POTENTIAL ELECTRICAL ARC FLASH HAZARDS PER 110.16 OF NEC.

21. ELECTRICAL CONTRACTOR SHALL PROVIDE NAMEPLATES FOR IDENTIFICATION OF ALL EQUIPMENT, SWITCHES, PANELS, ETC. THE NAMEPLATES SHALL BE LAMINATED PHENOLIC PLASTIC, BLACK FRONT, AND BACK WITH WHITE CORE, WHITE ENGRAVED LETTERS (1/4 in MINIMUM) ETCHED INTO THE WHITE CORE. ELECTRICAL CONTRACTOR SHALL PROVIDE A TYPE WRITTEN DIRECTORY CARD THAT ACCURATELY IDENTIFIES CIRCUITS INSIDE EACH PANEL. HANDWRITTEN LABELS ARE NOT ACCEPTABLE.

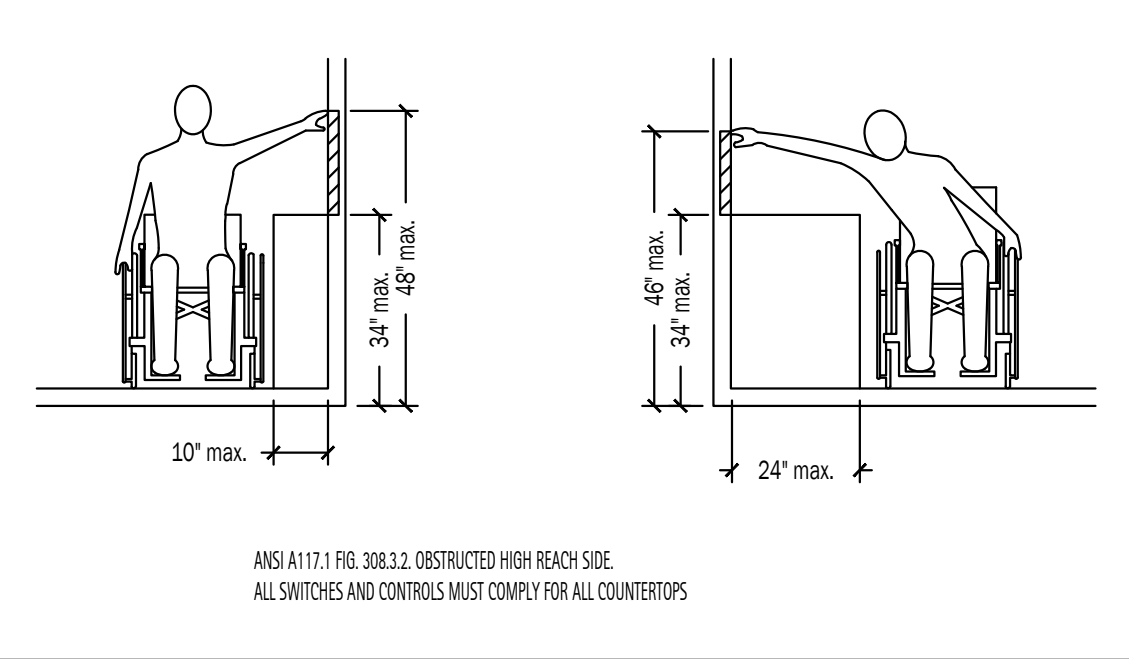

ELECTRICAL DESIGNER'S STATEMENT			
ELECTRICAL SYSTEM AND EQUIPMENT METHOD OF COMPLIANCE			
PRESCRIPTIVE: <u> X </u> PERFORMANCE: <u> </u> ENERGY COST BUDGET: <u> </u>			
LIGHTING SCHEDULE:			
LAMP TYPE REQUIRED IN FIXTURE:	SEE LIGHTING LEGEND		
NUMBER OF LAMPS PER FIXTURE:	SEE LIGHTING LEGEND		
BALLAST TYPE USED IN FIXTURE:	SEE LIGHTING LEGEND		
NUMBER OF BALLASTS IN FIXTURE:	SEE LIGHTING LEGEND		
TOTAL WATTAGE PER FIXTURE:	SEE LIGHTING LEGEND		
TOTAL INTERIOR WATTAGE SPECIFIED VS ALLOWED:	WATTS SPECIFIED	WATTS ALLOWED	
	770.0	1715.00	
OCCUPANCY	AREA (sf)	ALLOWANCE (W/sf)	WATTAGE ALLOWED
BATHROOM	1750	0.98	1715.00
TOTAL	1750		1715.00
EQUIPMENT SCHEDULES WITH MOTORS (NOT USED FOR MECHANICAL SYSTEMS)			
MOTOR HORSEPOWER: N/A			
NUMBER OF PHASES: N/A			
MINIMUM EFFICIENCY: N/A			
MOTOR TYPE: N/A			
NUMBER OF POLES: N/A			
DESIGNER STATEMENT: TO THE BEST OF MY KNOWLEDGE AND BELIEF, THE DESIGN OF THIS BUILDING COMPLIES WITH THE 2018 NORTH CAROLINA ENERGY CONSERVATION CODE.			
FOR THE ADDITIONAL PRESCRIPTIVE REQUIREMENT REQUIRED BY C406 OF 2018 NORTH CAROLINA ENERGY CONSERVATION CODE, WE ARE CHOOSING C406.3 - REDUCED LIGHTING POWER DENSITY.			
770 W SPECIFIED <= 1543 W (1715 W ALLOWED X 90%)			

LIGHTING DEVICE LEGEND		
SYMBOL	DESCRIPTION	REMARKS
⚡	SINGLE POLE WALL SWITCH	HEAVY DUTY, AC ONLY, COMMERCIAL GRADE GENERAL USE SNAP SWITCH COMPLYING WITH NEMA WD 6 AND WD 1. IVORY PLASTIC BODY WITH TOGGLE HANDLE. 120-277V, 20A. MEET FEDERAL SPECIFICATION W-S-896.
⚡	WALL MOUNTED OCCUPANCY SENSOR	WATTSTOPPER DW-100 LINE VOLTAGE OCCUPANCY SENSOR. ULTRA SONIC AND INFRARED.
⚡	LOW VOLTAGE SWITCH	WATTSTOPPER LVS-1 LOW VOLTAGE MOMENTARY CONTROL SWITCH.
⚡	3 WAY SWITCH	3-WAY TYPE SWITCH WITH SAME CHARACTERISTICS AS SINGLE POLE SWITCH ABOVE.
⊕	CEILING OCCUPANCY SENSOR	WATTSTOPPER, DT-300 LOW VOLTAGE OCCUPANCY SENSOR. 360° ULTRA SONIC AND INFRARED.
⊕	POWER PACK	WATTSTOPPER, BZ-150 LOW VOLTAGE POWER PACK FOR CEILING PACK SENSORS.
⊕	JUNCTION BOX	GALVANIZED METAL BOX CONSTRUCTED IN ACCORDANCE WITH 314.40 OF THE NEC.
⊕	EXHAUST FAN	VENT FAN, 120V, CFM AS NOTED MC TO PROVIDE AND VENT, EC TO WIRE.

POWER DEVICE LEGEND		
SYMBOL	DESCRIPTION	REMARKS
▶	DATA AND TELEPHONE JACK	PHONE/DATA OUTLET. EC TO INSTALL 3/4" C WITH PULL-STRING FROM OUTLET BOX TO ABOVE CEILING FOR FUTURE USE. JACKS AND COMMUNICATION CABLING BY OTHERS.
⊕	DUPLEX RECEPTACLE	NEMA 5-20R, HEAVY DUTY, COMMERCIAL GRADE, 125V, 20A COMPLYING WITH NEMA WD 6 AND WD 1. GFCI OR AFCI IF NOTED. "WP" DENOTES WEATHERPROOF COVER. "CH" DENOTES COUNTER HEIGHT. LISTED TAMPERPROOF IF NOTED. MEET FEDERAL SPECIFICATION W-C-586.
⊕	QUAD RECEPTACLE	QUAD RECEPTACLE OF SAME CHARACTERISTICS AS DUPLEX TYPE ABOVE.
⊕	DEDICATED RECEPTACLE	NEMA 5-20R, HEAVY DUTY, COMMERCIAL GRADE, 125V, 20A COMPLYING WITH NEMA WD 6 AND WD 1 UNLESS OTHERWISE NOTED ON PLANS. VERIFY PULL TYPE PRIOR TO PURCHASE & INSTALLATION. GFCI OR AFCI IF NOTED. "WP" DENOTES WEATHERPROOF COVER. "CH" DENOTES COUNTER HEIGHT. LISTED TAMPERPROOF IF NOTED. MEET FEDERAL SPECIFICATION W-C-596. MAY BE EITHER SIMPLEX, DUPLEX, OR QUAD.
⊕	FUSIBLE DISCONNECT SWITCH	HEAVY DUTY TYPE TYPE 1 ENCLOSURE IN INTERIOR APPLICATIONS, TYPE 3R ENCLOSURE IN EXTERIOR APPLICATIONS, FUSE ACCORDING TO NAMEPLATE DATA.
⊕	DISCONNECT SWITCH	HEAVY DUTY TYPE TYPE 1 ENCLOSURE IN INTERIOR APPLICATIONS, TYPE 3R ENCLOSURE IN EXTERIOR APPLICATIONS.
⊕	JUNCTION BOX	GALVANIZED METAL BOX CONSTRUCTED IN ACCORDANCE WITH 314.40 OF THE NEC.

LIGHT FIXTURE SCHEDULE											
MARK	DESCRIPTION	LOUVER/LENS	LAMPS			VOLTAGE	MAX WATTAGE	MOUNTING	REMARKS	MFG	MODEL
			TYPE	QTY.	CCT						
A	4' 2 LAMP VAPOR PROOF STRIP LIGHT	-	LED	-	-	120	64	SURFACE	2	EPCO	G-4-LED-FX-S-41-34
B	6" CAN LIGHT	-	LED	1	-	120	12	RECESSED	2	JUNO	IC22LED-64-091UM-35K-90CRI-MVOLT
C	OUTDOOR FAN W/O LIGHT KIT	-	LED	-	-	120	67	SURFACE	2	ZOONIX	MA4660
EXH	LED EXIT/COMBO W/ BATTERY BACKUP	ACRYLIC	LED	MULT.	N/A	120	4	VARIES	1,2	EMERGI-LITE	LSMX42N0C
OE	EXTERIOR OVAL LED EQUIPMENT LIGHT	POLYCARBONATE	LED	2	-	120	2	SURFACE	1	EELP	DEM-EM

- FIXTURE SHALL HAVE BATTERY BACKUP FOR 90 MINUTE ILLUMINATION.
- OR EQUAL BY COPPER, PHILIPS, DAY-BRITE LIGHTING, GE, LITHONIA, OR OWNER APPROVED SELECTION
- TO BE LAMPED WITH LED EQUIVALENT BULB



Kilian Engineering, Inc.
 PO Box 3301, Henderson, NC 27536 | www.kilianengineering.com
 (919) 524-438-8718 | CORPORATE LICENSE C-2277

DATE	07/25/22
REVISION	
NO.	PERMIT SET

SHEET DISCRPTION
Electrical Schedules & Notes

PROJECT #: 22458
 DATE ISSUED: 07/25/2022
 DRAWING BY: DBAS
 CHECKED BY: MWK/JLH

WOODGROVE
 DR HORTON
 BATHHOUSE & POOL
 HARNETT COUNTY, NC

LIGHTING PLAN HEX NOTES

1. EXHAUST FAN SUSPENDED IN ATTIC TO BE WIRED FOR CONTINUOUS OPERATION. COORDINATE WITH M.C.
2. PROVIDE 60 MINUTE SWITCH FOR FAN. PROVIDE IN WEATHERPROOF ENCLOSURE.
3. PUMP ROOM AND CHEM. ROOM LIGHTS TO BE TIED TO SAME MOTION SENSOR.
4. EC TO TIE EXHAUST FAN AND LIGHTING FIXTURES TO SAME CONTROL SWITCH.
5. MOTION SENSOR TO BE SET ON 20 MINUTE TIMER.
6. PORCH/PAVILION/HALL LIGHTING FIXTURE CONTROLLED VIA PHOTOCELL LOCATED ON NORTH FACE OF BUILDING.
7. EGRESS LIGHTING EXEMPT FROM RESTROOMS PER NC BUILDING CODE 1008.3.3.
8. PROVIDE LOW VOLTAGE OVERRIDE SWITCH AS SHOWN.
9. AREA IS CORROSIVE ENVIRONMENT PER NEC 680.14. FOLLOW WIRING METHODS IN NEC 680.14(B).

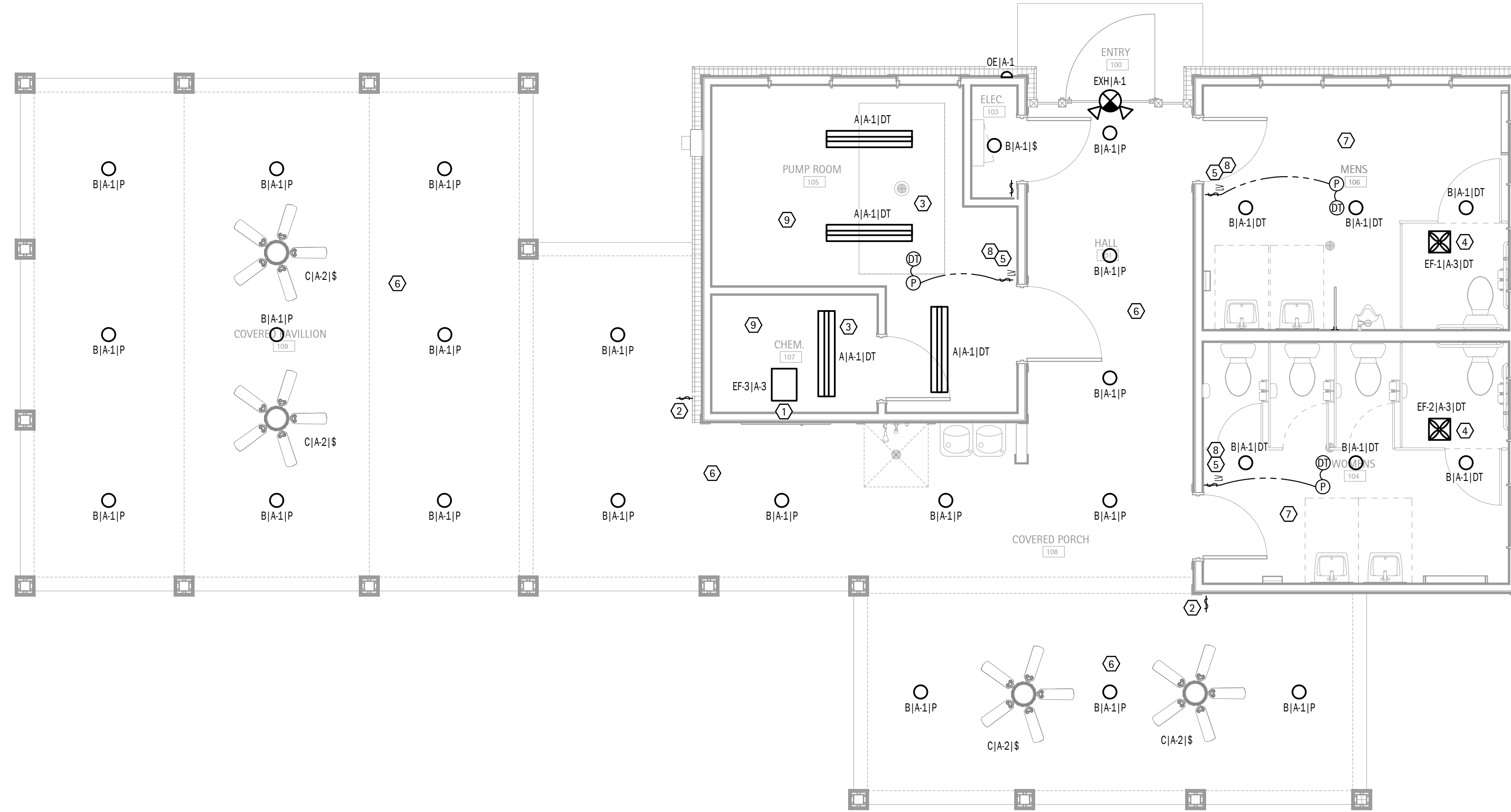

LIGHTING CIRCUIT DESIGNATIONS

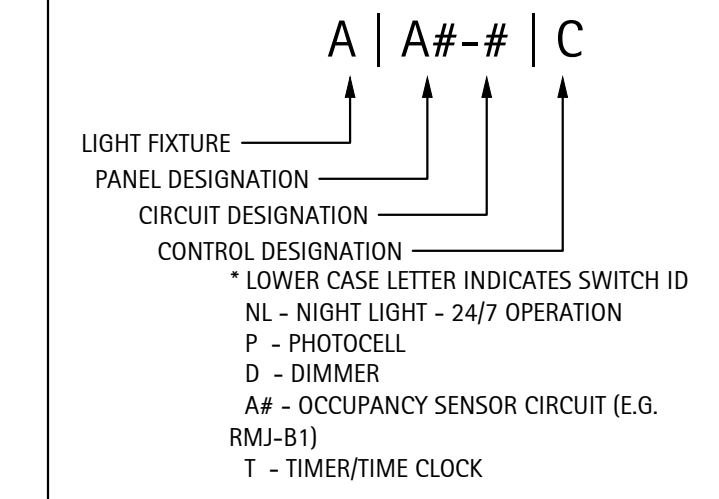

LIGHTING PLAN: SCALE - 1/4" = 1'0" 1

POWER PLAN HEX NOTES

1. PROVIDE (2) 1" CONDUITS WITH CIRCUITS AS SHOWN TO POOL FOR POOL LIGHTS AND OTHER POOLSIDE EQUIPMENT. PROVIDE (3) 1" CONDUITS FROM SPARE POOL CIRCUITS AS SHOWN AND CAP RIGHT OUTSIDE ELECTRICAL ROOM. COORDINATE EXACT LOCATIONS WITH G.C. AND POOL CONTRACTOR. CIRCUIT TO BE CONTROLLED VIA TIME CLOCK AT PANEL. POOL LIGHTS TO BE WIRED VIA INTERMATIC JUNCTION BOX TRANSFORMER (MODEL PJBX52100). REFER TO PANEL SCHEDULE FOR CIRCUIT DESIGNATIONS.
2. AREA IS CORROSIVE ENVIRONMENT PER NEC 680.14. FOLLOW WIRING METHODS IN NEC 680.14(B).
3. PROVIDE POWER TO NON-FUSED DISCONNECT FOR POOL AND FEATURE PUMPS. PUMPS MUST HAVE GFCI PROTECTION. PROVIDE GFCI BREAKER IN PANEL. DISCONNECT MUST HAVE NEMA 4X RATED ENCLOSURE. COORDINATE EXACT LOCATION AND SPEC WITH G.C. AND POOL CONTRACTOR BEFORE BEGINNING WORK. FINAL CONNECTIONS BY E.C.
4. PROVIDE POWER TO EMERGENCY PHONE RECEPTACLE. FIELD VERIFY LOCATION WITH LOCAL AHJ.
5. PROVIDE EMERGENCY "PUSH IN" POWER OFF SWITCH FOR POOL PUMPS. VERIFY LOCATION WITH LOCAL AHJ. WIRE TO SHUNT TRIP BREAKERS IN PANEL. SEE PANEL SCHEDULE. SEE ARCHITECTURAL PLANS FOR LOCATION OF "PUSH IN" POWER OFF SWITCH.
6. WATER HEATER DISCONNECT LOCATED ABOVE CEILING.
7. FLUSH MOUNT JUNCTION BOX FOR UNIT HEATER.
8. E.C. TO COORDINATE WITH POOL CONTRACTOR TO ENSURE A GFCI/WEATHER PROOF RECEPTACLE IS WITHIN 20' OF EDGE OF POOL (BUT NO CLOSER THAN 6') AS REQUIRED BY NEC 680.22(A)(1). PROVIDE ON CIRCUIT 3 IN PANEL A.
9. RECEPTACLE IN HOTBOX FOR FREEZE PROTECTION. VERIFY EXACT LOCATION OF HOTBOX WITH UTILITY PLANS BY OTHERS.
10. EC TO COORDINATE WITH PC FOR HEAT TRACE ON COLD WATER SUPPLY LINES. SEE CIRCUIT IN PANEL A (A-8).
11. GFCI PROTECTED BY BREAKER AT PANEL.

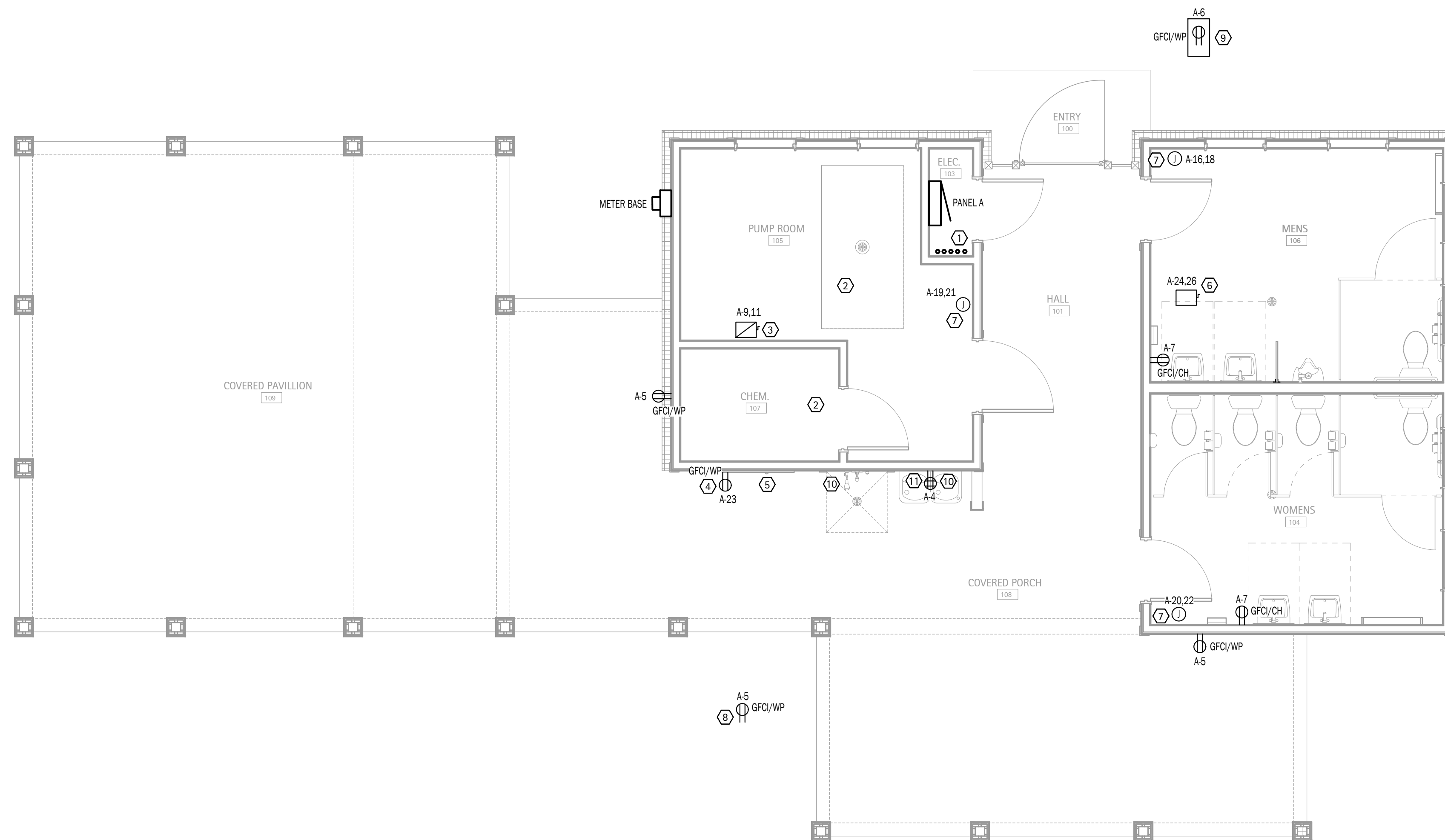

POWER CIRCUIT DESIGNATIONS

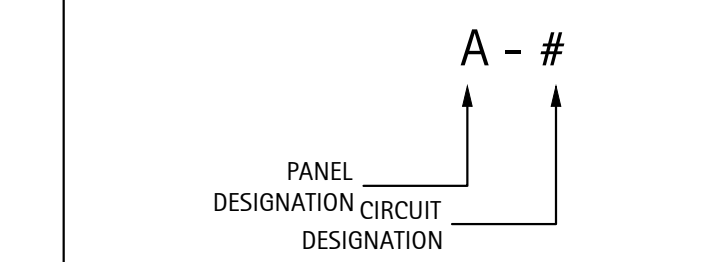

POWER PLAN: SCALE - 1/4" = 1'0" 2



Kilian Engineering, Inc.
 PO Box 3301, Henderson, NC 27536 | www.kilianengineering.com
 (919) 552-4588, 8778 | CORPORATE LICENSE C-2277

NO.	REVISION	DATE
1	PERMIT SET	07/25/22

SHEET DISCUSSION
Lighting & Power Plans

PROJECT #: 22458
 DATE ISSUED: 07/25/2022
 DRAWING BY: DBAS
 CHECKED BY: MWK/JLH

WOODGROVE
 DR HORTON
 BATHHOUSE & POOL
 HARNETT COUNTY, NC

PANEL A								
CKT	LOAD	BKR	LOAD		BKR	LOAD	CKT	
			kVA	PH				
1	LIGHTS	20/1	0.77	A	0.34	20/1	PORCH/PAVILION FANS	2
3	EXHAUST FANS	20/1	1.06	B	0.36	20/1	WATER FOUNTAIN	4
5	PORCH/DECK RECEPTACLES	20/1	0.54	A	0.18	20/1	HOTBOX RECEPTACLE	6
7	BATHROOM RECEPTACLE	20/1	0.36	B	1.20	20/1	HEAT TRACE	8
9	5 HP POOL PUMP	60/2	3.36	A	1.20	20/1	POOL LIGHTS AND ACCESSORIES	10
11			3.36	B	1.20	20/1	POOL LIGHTS AND ACCESSORIES	12
13	SHUNT TRIP		0.00	A	0.00	20/1	POOL SPARE	14
15	POOL SPARE	20/1	0.00	B	2.40	20/2	UNIT HEATER 1	16
17	POOL SPARE	20/1	0.00	A	2.40		UNIT HEATER 2	18
19	UNIT HEATER 2	20/2	2.40	B	2.40	20/2	UNIT HEATER 3	20
21	UNIT HEATER 2	20/2	2.40	A	2.40		UNIT HEATER 3	22
23	EMERGENCY PHONE RECEPT.	20/1	0.18	B	2.25	30/2	WATER HEATER	24
25	SPARE	20/1	0.00	A	2.25		SPARE	26
27	SPARE	20/1	0.00	B	0.00	20/1	SPARE	28
29	SPACE		0.00	A	0.00		SPACE	30
31	SPACE		0.00	B	0.00		SPACE	32
33	SPACE		0.00	A	0.00		SPACE	34
35	SPACE		0.00	B	0.00		SPACE	36
37	SPACE		0.00	A	0.00		SPACE	38
39	SPACE		0.00	B	0.00		SPACE	40
41	SPACE		0.00	A	0.00		SPACE	42
			kVA	PH	AMPS			
			15.8	A	132			
			17.2	B	143			
VOLTAGE/PHASE		120/240, 1P, 3W						
BUS RATING		200A						
MAIN CIRCUIT BREAKER RATING		200A MAIN BREAKER						
AIC RATING		22K - EC TO VERIFY						
SERVICE ENTRANCE RATED		YES						
ENCLOSURE		NEMA 1						
MOUNTING		SURFACE						

NEC ELECTRIC DEMAND SUMMARY 120/240V, 1P, 3W						
EQUIPMENT	DEMAND FACTOR	kVA		LOAD kVA	NEC REFERENCE	NOTES/CALCULATIONS
		A	B			
LIGHTING	125%	1.23	1.23	2.45	220.12	1750 SF X 1.4 VA/SF
RECEPTACLES < 10 kVA	100%	0.72	0.72	1.44	220.44	
HVAC	100%	7.20	8.26	15.46	--	BASED ON MCA
WATER HEATER	125%	2.81	2.81	5.62	422.13	STORAGE TANK <120 GAL @ 125%
POOL EQUIPMENT	100%	5.40	6.60	12.00	430.24	LARGEST MOTOR @ 125%
DEMAND kVA PER PHASE		17.36	19.62			
DEMAND AMPS PER PHASE		145	163			

THE CALCULATED LIGHTING LOAD EXCEEDS THE CONNECTED LIGHTING LOAD.

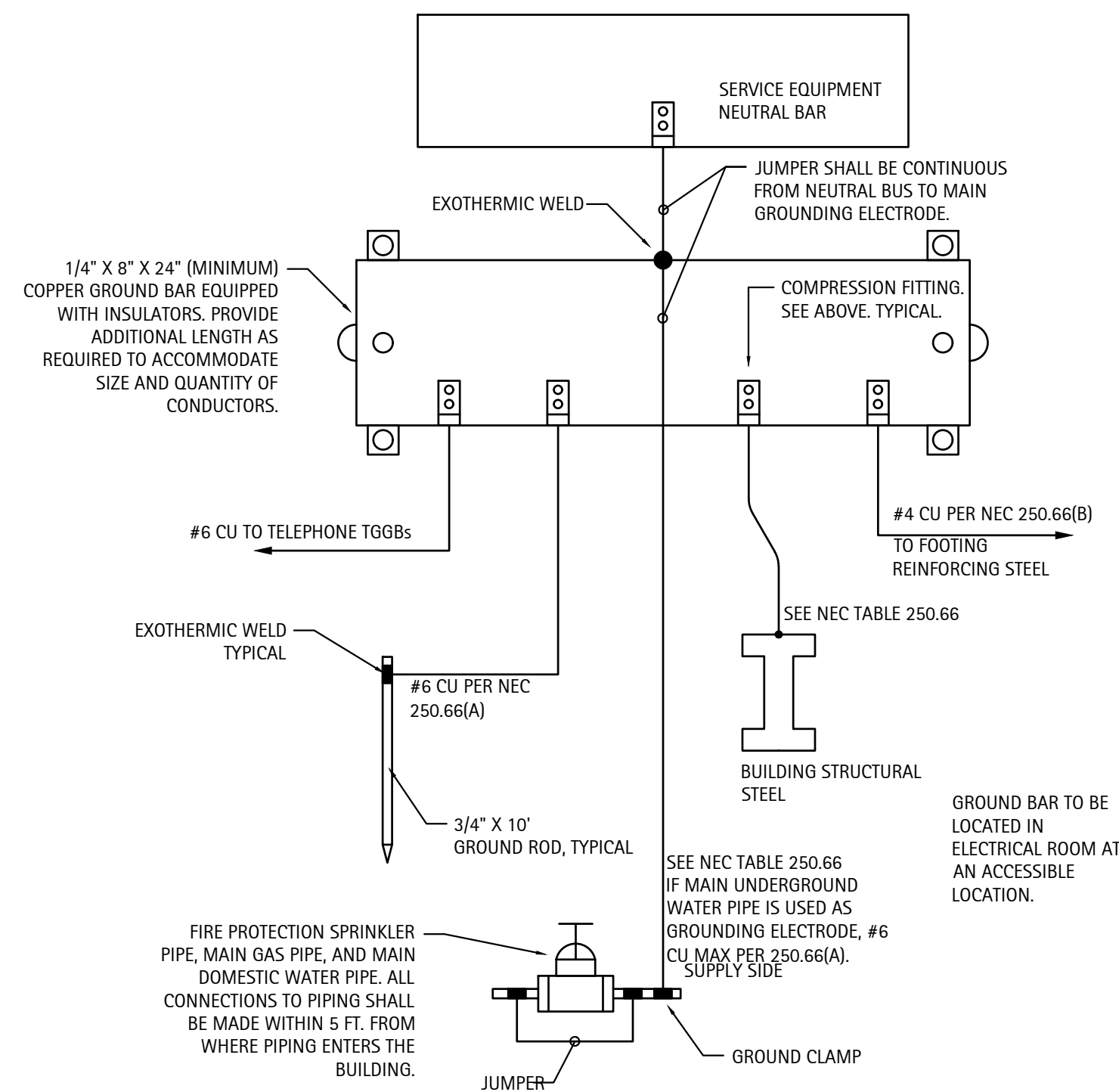

GROUNDING DETAIL-NO SCALE

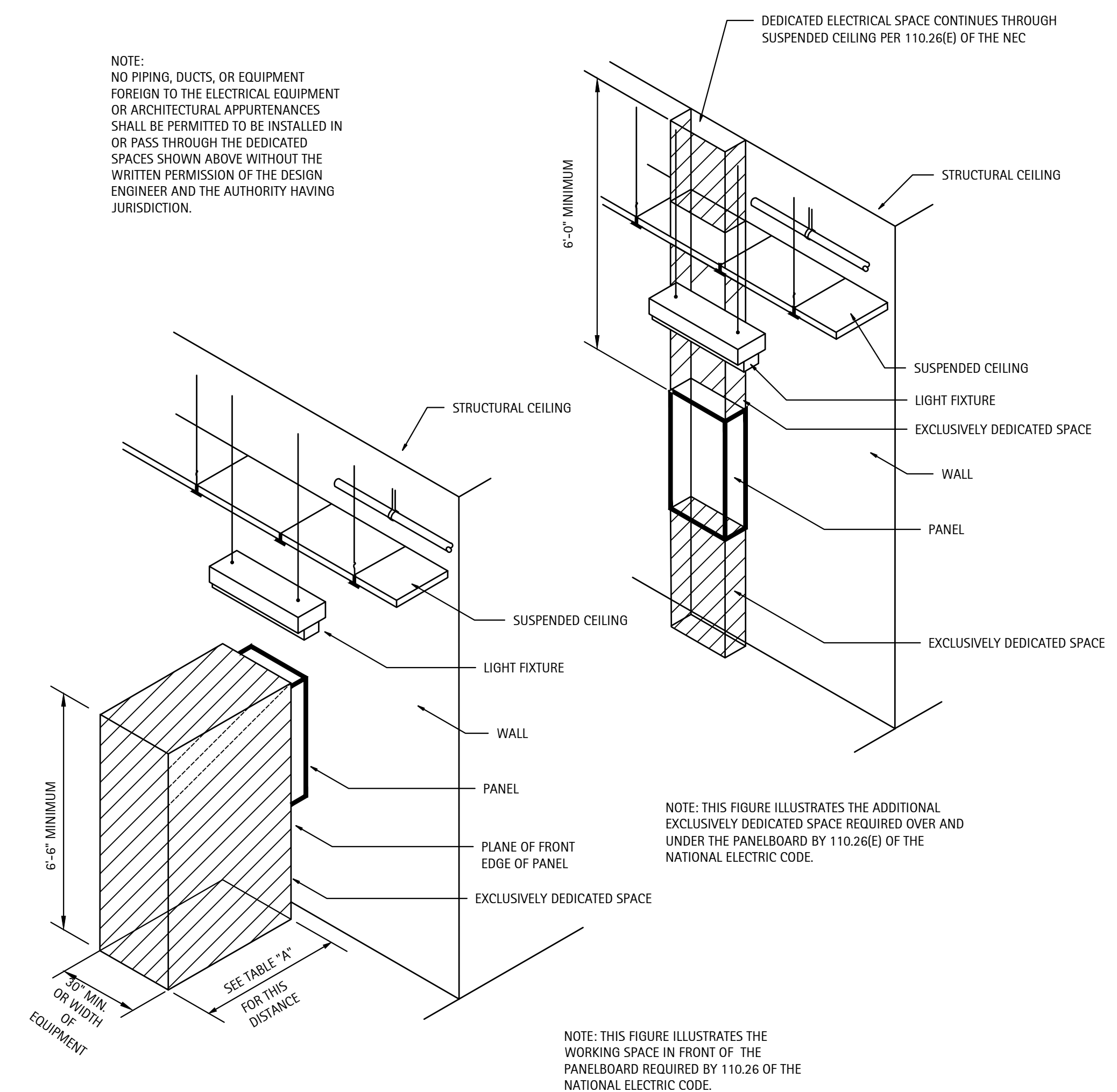

NOTE: WHERE THE CONDITIONS ARE AS FOLLOWS:

- CONDITION 1 - EXPOSED LIVE PARTS ON ONE SIDE OF THE WORKING SPACE AND NO LIVE OR GROUNDED PARTS ON THE OTHER SIDE OF THE WORKING SPACE, OR EXPOSED LIVE PARTS ON BOTH SIDES OF THE WORKING SPACE THAT ARE EFFECTIVELY GUARDED BY INSULATING MATERIALS.
- CONDITION 2 - EXPOSED LIVE PARTS ON ONE SIDE OF THE WORKING SPACE AND GROUNDED PARTS ON THE OTHER SIDE OF THE WORKING SPACE. CONCRETE, BRICK, OR TILE WALLS SHALL BE CONSIDERED AS GROUNDED.
- CONDITION 3 - EXPOSED LIVE PARTS ON BOTH SIDES OF THE WORKING SPACE.

TABLE 110.26(A)(1) WORKING SPACE			
VOLTAGE TO GROUND, NOMINAL	MINIMUM CLEAR DISTANCE (FEET)		
	CONDITION 1	2	3
0-150	3	3	3
151-600	3	3-1/2	4

REQUIRED CLEARANCES-NO SCALE

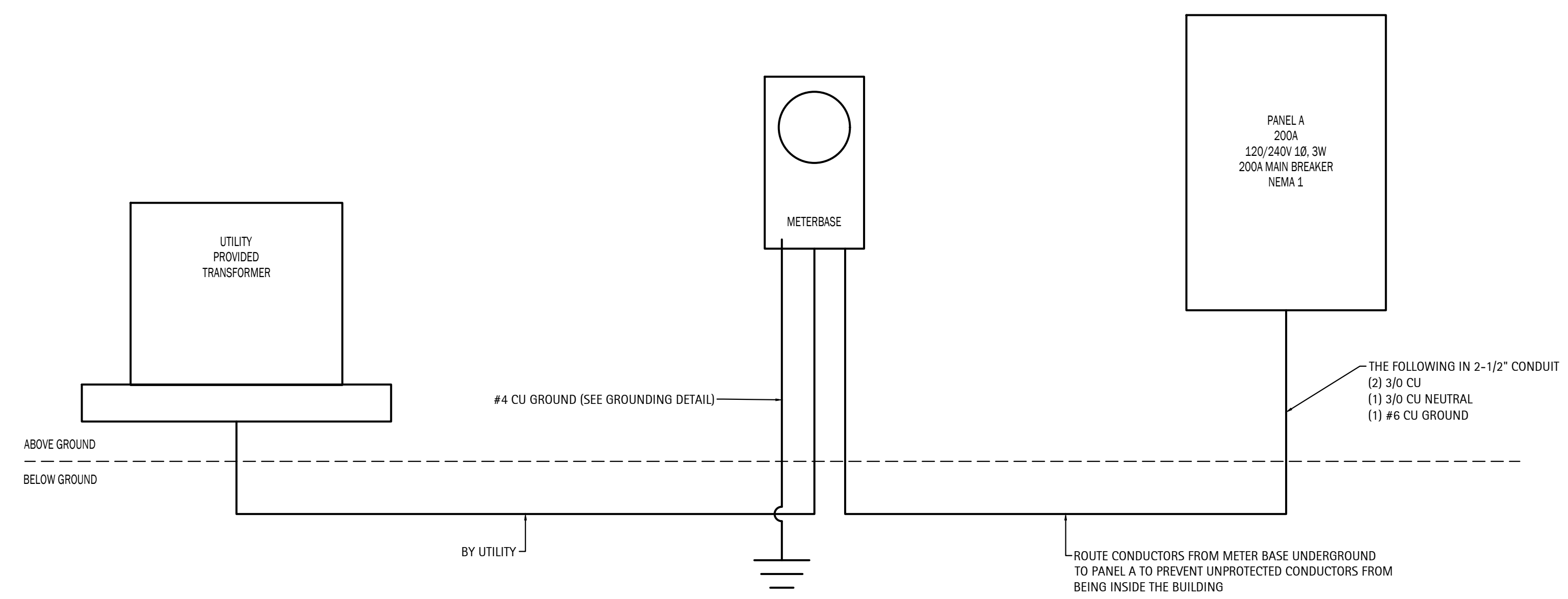

Kilian Engineering, Inc.
 PO Box 3301, Healdston, NC 27536 | www.kilianengineering.com
 (919) 458-8718 | CORPORATE LICENSE C-2277

NO.	REVISION	DATE
		07/25/22
1	PERMIT SET	

SHEET DISCRPTION
Panel Schedules & Power Riser

PROJECT #: 22458
 DATE ISSUED: 07/25/2022
 DRAWING BY: DBAS
 CHECKED BY: MWK/JLH

WOODGROVE
 DR HORTON
 BATHHOUSE & POOL
 HARNETT COUNTY, NC



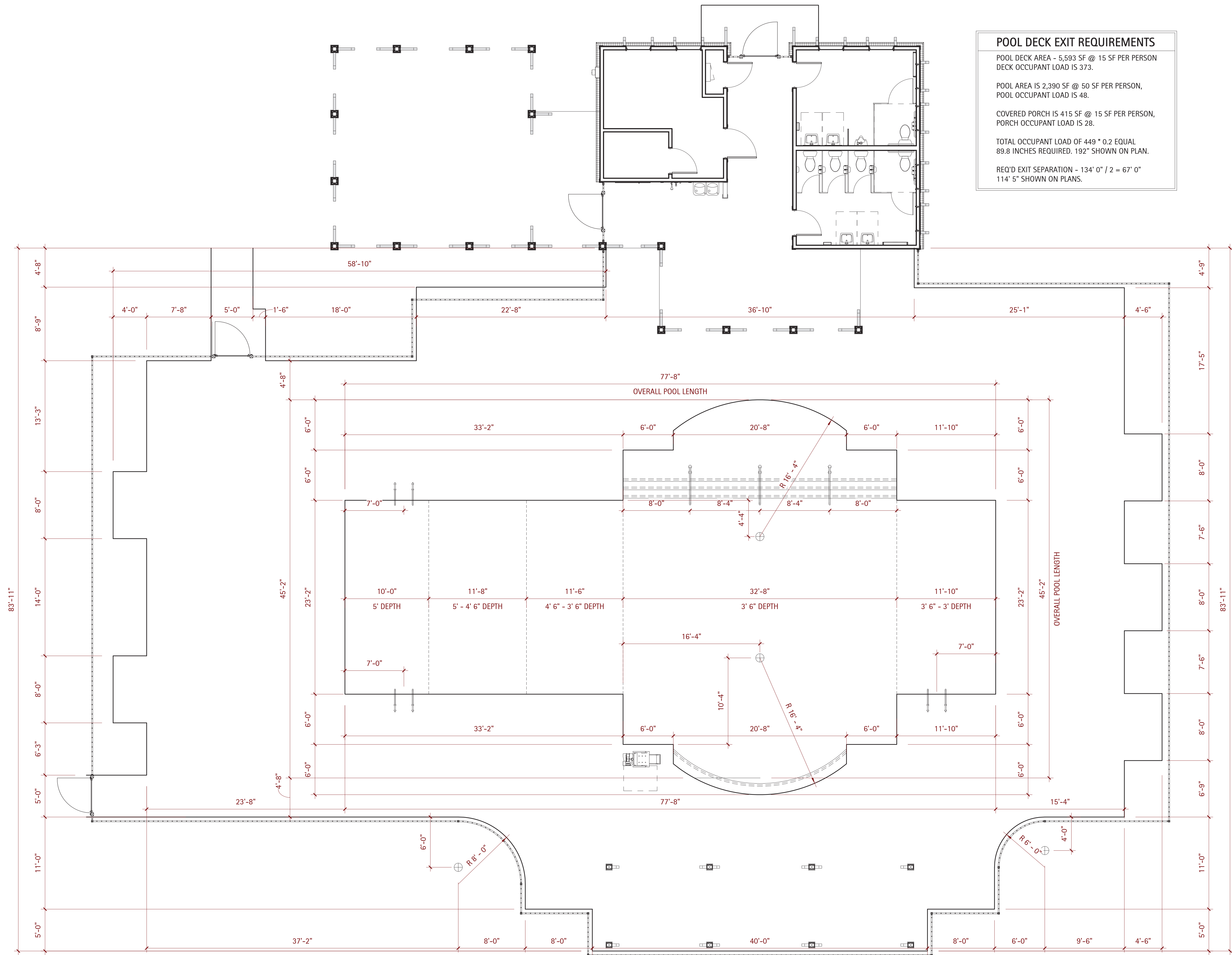

D. CLUGSTON



**Kilian
Engineering,
Inc.**



PO Box 3301, Healdson, NC 27536 | www.kilianeengineering.com
(919) 524-4388/8778 | CORPORATE LICENSE C-2277

NO.	REVISION	DATE

SHEET DISCUSSION

**Pool
Dimension
Plan**

PROJECT #: 2022002

DATE ISSUED: 07/20/2022

DRAWING BY: JVD

CHECKED BY: DSC/JLH

1 Pool Dimension Plan
SP1 3/16" = 1'-0"

SP1



D. CLUGSTON



Kilian Engineering, Inc.



Table with columns: DATE, REVISION, NO.

SHEET DISCUSSION Pool Layout Plan

PROJECT #: 2022002 DATE ISSUED: 07/20/2022 DRAWING BY: JVD CHECKED BY: DSC/JLH

WOODGROVE DR HORTON BATHHOUSE & POOL HARNETT COUNTY, NC

SP2

POOL EQUIPMENT SCHEDULE table with columns: TAG, COUNT, MANUFACTURER, MODEL, COMMENTS

POOL DECK SIGNAGE REQUIREMENTS POOL SIGNAGE TO BE POSTED IN THE MAIN POOL AREA: SIGN "A" - 4" TALL LETTERS [WARNING - NO LIFEGUARD ON DUTY] SIGN "B" - 1" TALL LETTERS - A MIN. OF (2) THIS PROJECT

POOL SAFETY REQUIREMENTS PROVIDE SAFETY PROVISIONS PER SECTION .2530. THE MINIMUM BEING: A. 12' LONG (MINIMUM) METAL POLE WITH A BODY HOOK SECURELY ATTACHED...

MAIN POOL DATA table with columns: POOL DIMENSIONS, POOL DEPTHS, POOL VOLUME, SURFACE AREA, PERIMETER, COPING, REQUIRED FLOW, DESIGN FLOW, SHELL MATERIAL, INTERIOR FINISH, BATHER LOAD, BACKWASH TO, WATER SOURCE, PIPE SIZING, MAIN DRAINS, SKIMMERS, VACUUM LINE, INLETS, FILTER TYPE, SIZE PROVIDED, SIZE REQUIRED, MEDIA CIRC. RATE, BACKWASH RATE, TURNOVER RATE

BUILDING FIXTURE DATA TOTAL BATHER LOAD = 2,390 /15 = 160 (50% - 50% SPLIT) = 80 CLUBHOUSE & PUMP HOUSE MINIMUM FIXTURE REQUIREMENTS FOR HEALTH DEPARTMENT APPROVAL ARE: 80 MEN - 1 LAVATORIES - 1 WATER CLOSET(S) - 1 URINAL(S) 80 WOMEN - 1 LAVATORIES - 1 WATER CLOSET(S) 1 SHOWER IS REQUIRED SEE ARCHITECTURAL PLANS BY OTHERS FOR RESTROOM LOCATION & LAYOUTS

POOL DESIGN NOTES A. SEE PLANS BY OTHERS FOR CONSTRUCTION OF BATHHOUSE, PUMP & CHEMICAL STORAGE ROOMS, SITE WORK, ETC. B. POOL IS DESIGNED FOR DAWN TO DUSK SWIMMING ONLY

Overall Pool Layout Plan 3/16" = 1'-0"

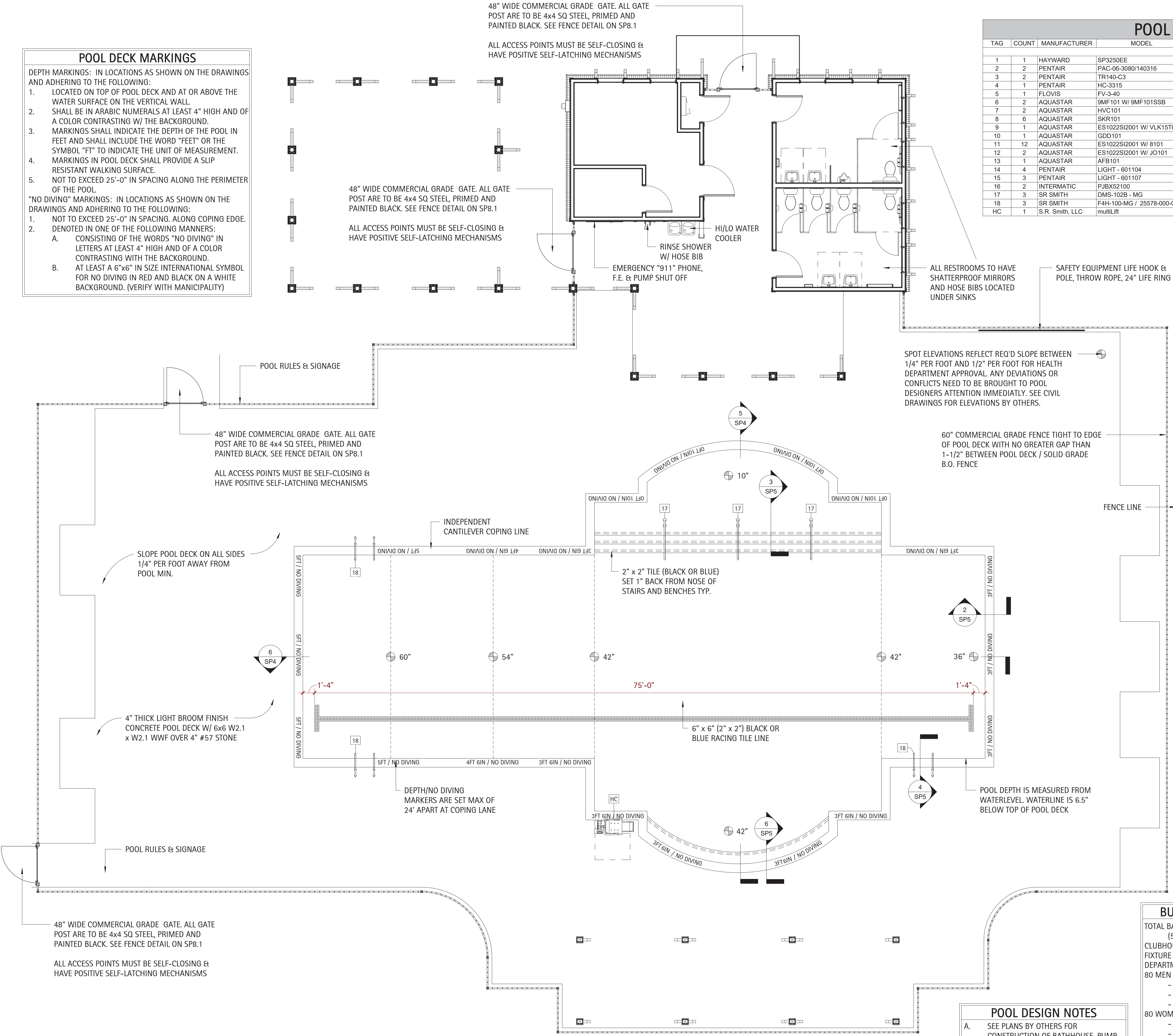

POOL DECK MARKINGS DEPTH MARKINGS: IN LOCATIONS AS SHOWN ON THE DRAWINGS AND ADHERING TO THE FOLLOWING: 1. LOCATED ON TOP OF POOL DECK AND AT OR ABOVE THE WATER SURFACE ON THE VERTICAL WALL...

48" WIDE COMMERCIAL GRADE GATE. ALL GATE POST ARE TO BE 4x4 SQ STEEL, PRIMED AND PAINTED BLACK. SEE FENCE DETAIL ON SP8.1 ALL ACCESS POINTS MUST BE SELF-CLOSING & HAVE POSITIVE SELF-LATCHING MECHANISMS

POOL RULES & SIGNAGE 48" WIDE COMMERCIAL GRADE GATE. ALL GATE POST ARE TO BE 4x4 SQ STEEL, PRIMED AND PAINTED BLACK. SEE FENCE DETAIL ON SP8.1 ALL ACCESS POINTS MUST BE SELF-CLOSING & HAVE POSITIVE SELF-LATCHING MECHANISMS

SLOPE POOL DECK ON ALL SIDES 1/4" PER FOOT AWAY FROM POOL MIN. 4" THICK LIGHT BROOM FINISH CONCRETE POOL DECK W/ 6x6 W2.1 x W2.1 WWF OVER 4" #57 STONE

48" WIDE COMMERCIAL GRADE GATE. ALL GATE POST ARE TO BE 4x4 SQ STEEL, PRIMED AND PAINTED BLACK. SEE FENCE DETAIL ON SP8.1 ALL ACCESS POINTS MUST BE SELF-CLOSING & HAVE POSITIVE SELF-LATCHING MECHANISMS



D. CLUGSTON



Kilian Engineering, Inc. PO Box 3301, Healdston, NC 27536 | www.kilianengineering.com | (919) 524-4388 (877) 811-1111 | CORPORATE LICENSE C-2277

Table with columns: NO., REVISION, DATE

SHEET DISCUSSION Piping & Electrical Plan

PROJECT #: 2022002 DATE ISSUED: 07/20/2022 DRAWING BY: JVD CHECKED BY: DSC/JLH

WOODGROVE DR HORTON BATHHOUSE & POOL HARNETT COUNTY, NC

SP3

POOL EQUIPMENT SCHEDULE

Table with columns: TAG, COUNT, MANUFACTURER, MODEL, COMMENTS. Lists equipment like pumps, filters, skimmers, and lights.

UNDERWATER LIGHTING DATA

MAIN POOL AREA: 2,390 SQFT. 2,390 SF x 0.5 WATTS = 1,195 WATTS. LIGHTING PROVIDED (12V LED EQ.) 4 GLOBRITES @ 190 WATTS 3 INTELLIBRITE @ 300 WATTS. TOTAL PROVIDED: 1,660 WATTS

PUMP FLOW PIPE SIZING

SP3250EE PUMP FLOW AT 65 FT OF WATER IS 175 GPM, WITH SPECIFIED: 4" MAIN DRAIN PIPING VELOCITY IS 4.41 FPS. 4" SKIMMER PIPING VELOCITY IS 4.41 FPS. 3" RETURN PIPING VELOCITY IS 7.60 FPS.

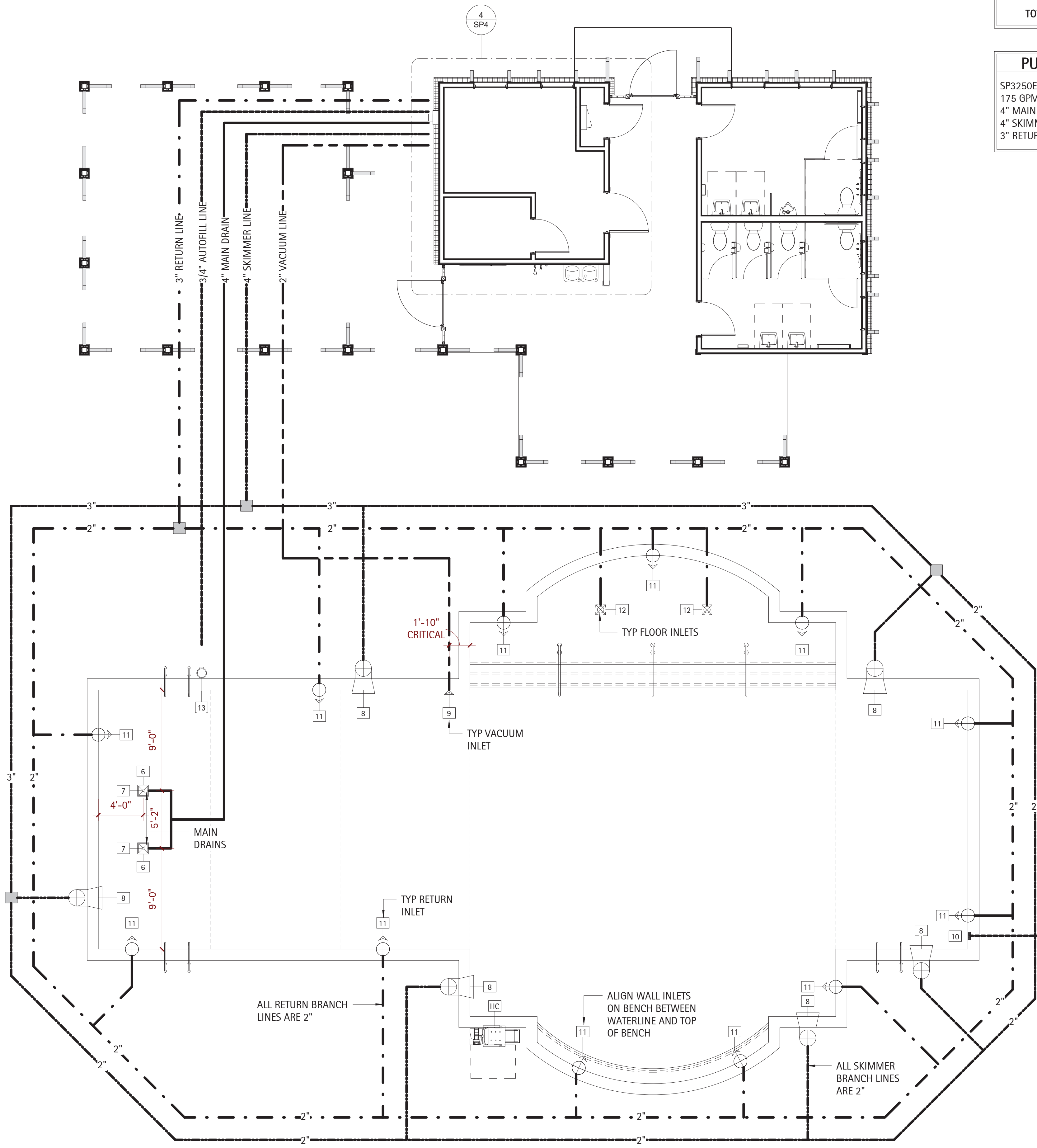

2 SP3 Return & Suction Plan 3/16" = 1'-0"

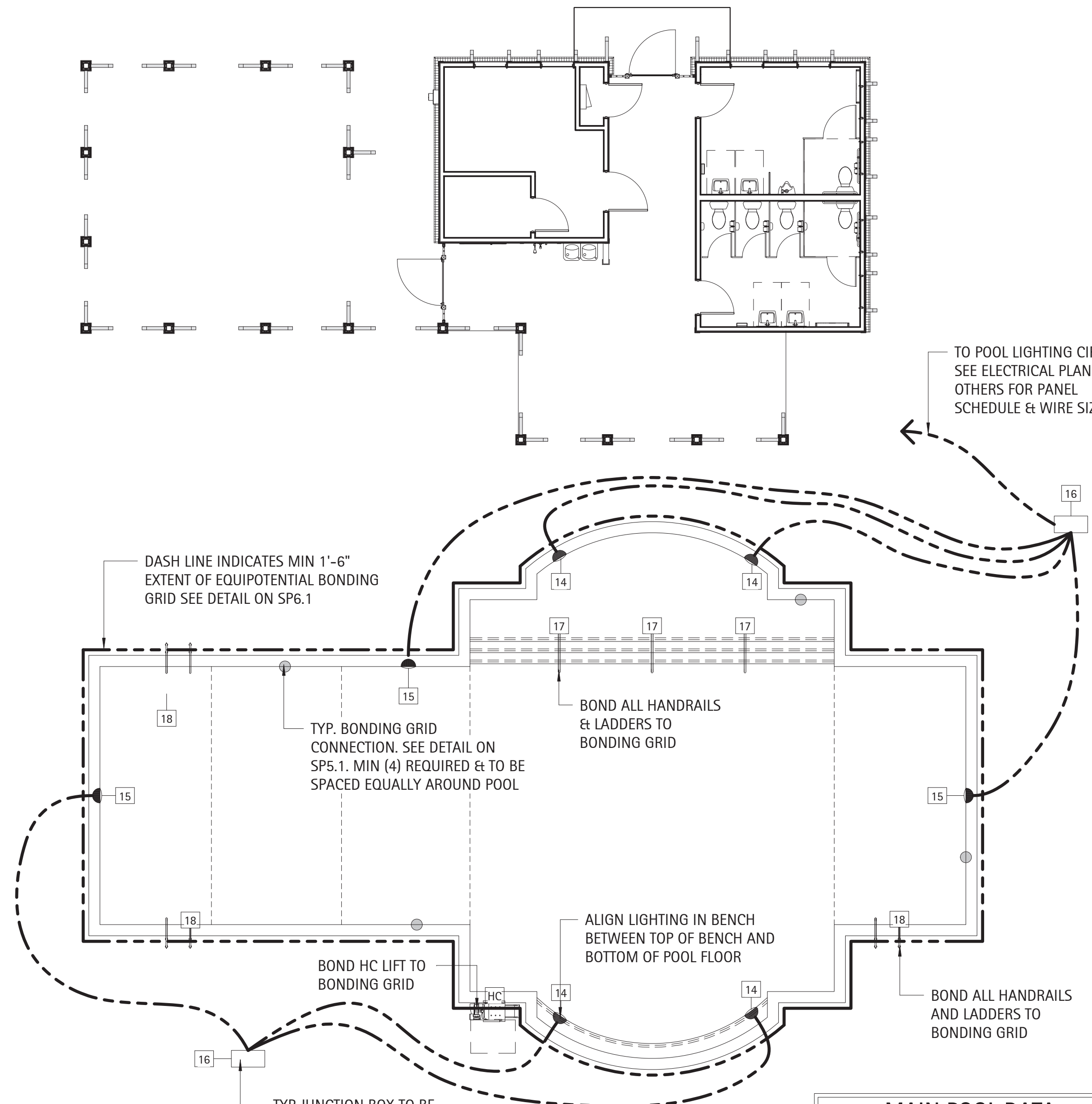

1 SP3 Lighting Plan 1/8" = 1'-0"

MAIN POOL DATA table with rows for Pool Dimensions, Pool Depths, Pool Volume, Surface Area, Perimeter, Coping, Required Flow, Design Flow, Shell Material, Interior Finish, Bather Load, Backwash To, Water Source, Pipe Sizing, Main Drains, Skimmers, Vacuum Line, Inlets, Filter Type, Size Provided, Size Required, Media Circ. Rate, Backwash Rate, Turnover Rate.



D. CLUGSTON



Kilian Engineering, Inc. PO Box 3301, Healdston, NC 27536

Table with columns for DATE, REVISION, and NO.

SHEET DISCRPTION: Enlarged Pump Room & Pool Section

PROJECT #: 2022002 DATE ISSUED: 07/20/2022 DRAWING BY: JVD CHECKED BY: DSC/JLH

WOODGROVE DR HORTON BATHHOUSE & POOL HARNETT COUNTY, NC

SP4

POOL EQUIPMENT SCHEDULE table with columns: TAG, COUNT, MANUFACTURER, MODEL, COMMENTS

CHEMICAL STORAGE DATA CHEMICAL STORAGE REQUIREMENTS FOR A 62,463 GALLON POOL ARE: 5 SF FOR FIRST 10,000 GALLONS OF POOL + 1 SF FOR EACH ADDITIONAL 3,000 GALLONS OF POOL UP TO 100 SF OF STORAGE

PUMP FLOW PIPE SIZING SP3250EE PUMP FLOW AT 65 FT OF WATER IS 175 GPM, WITH SPECIFIED: 4" MAIN DRAIN PIPING VELOCITY IS 4.41 FPS.

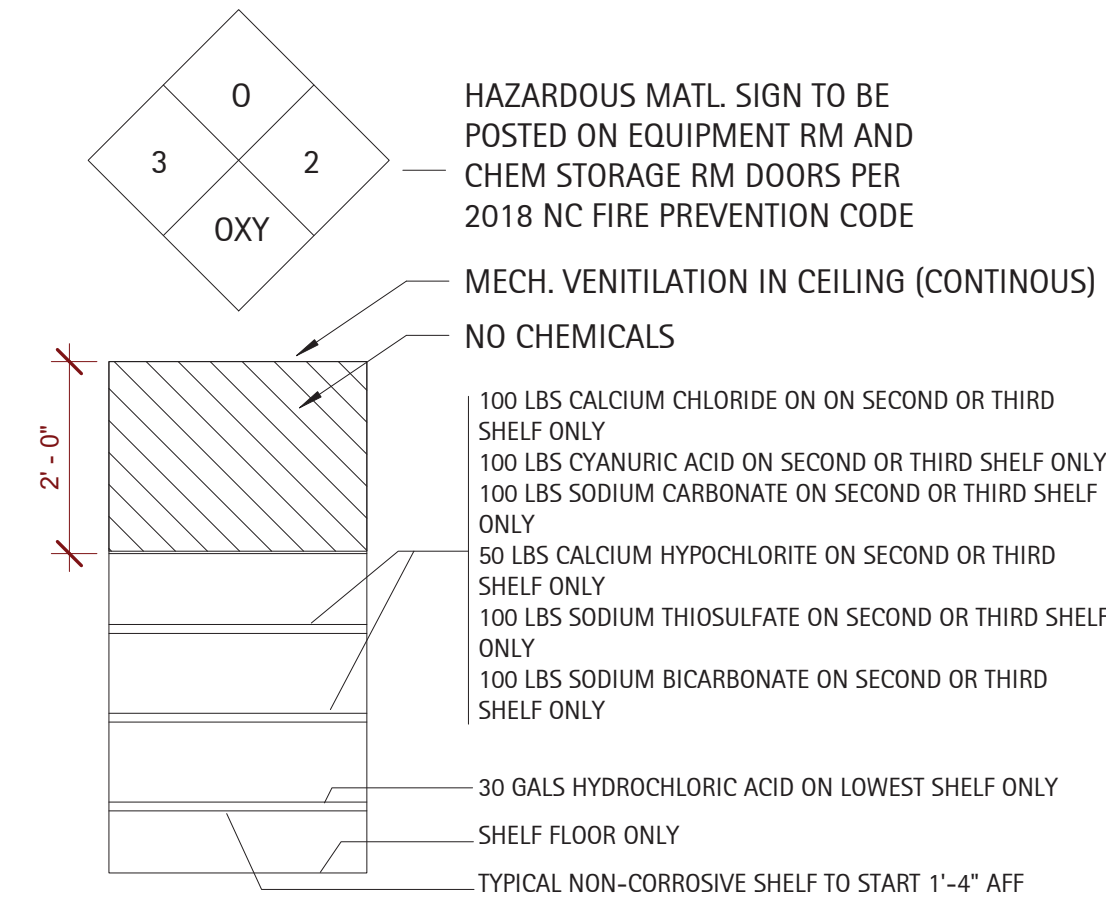
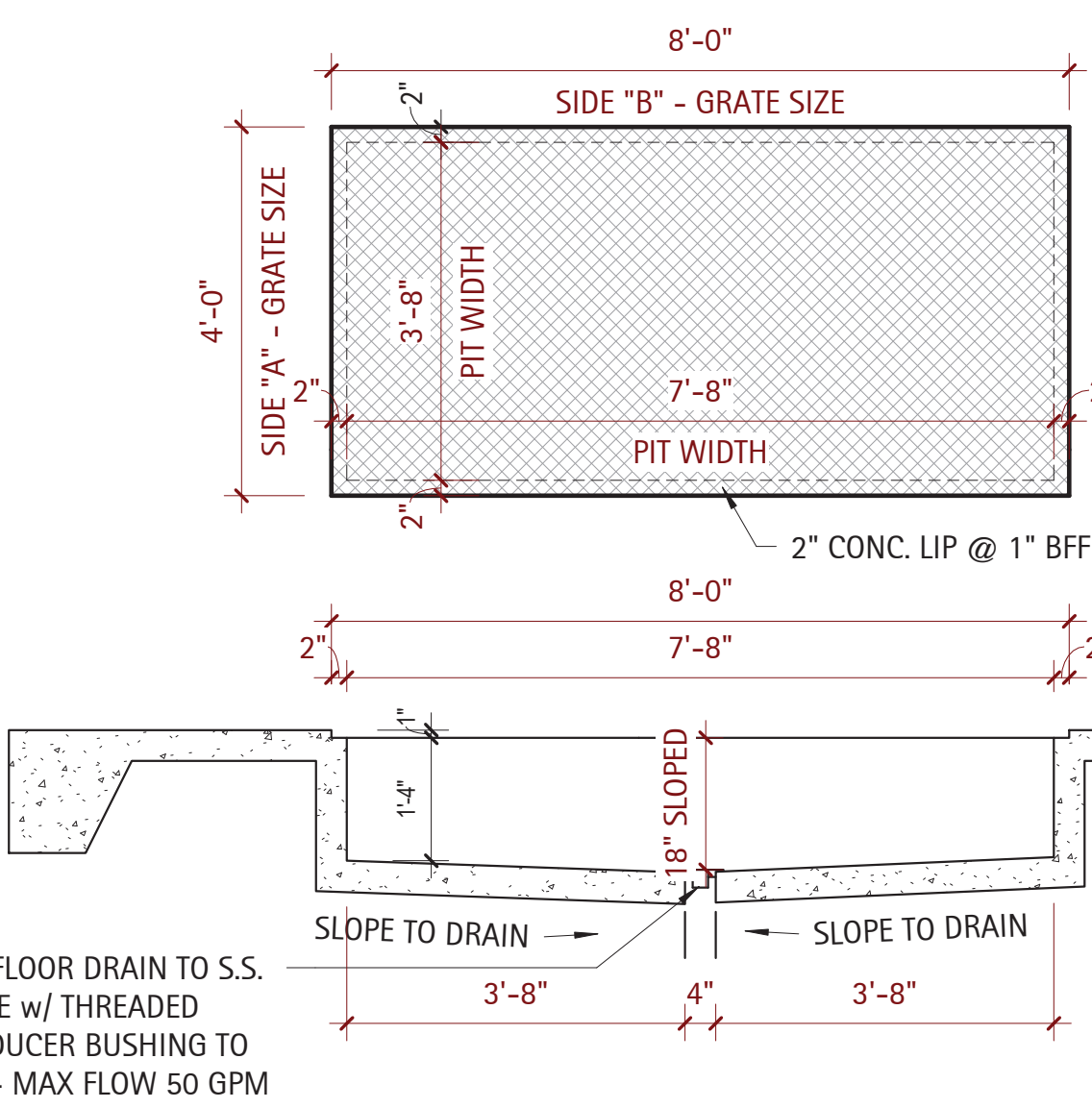
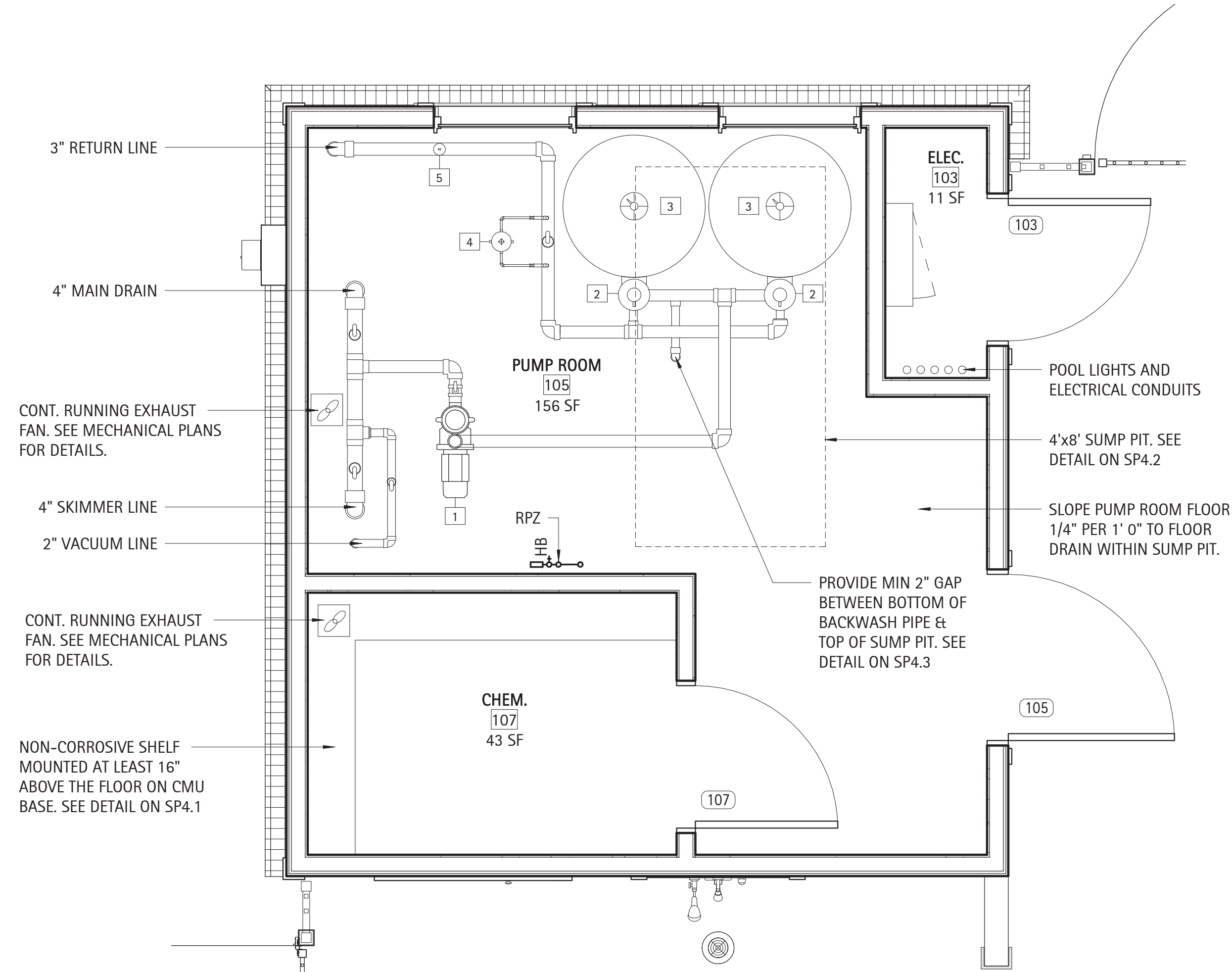

BACWASH SUMP SIZING: PUMP GPM (BACKWASH) = 130 GPM FILTRATION FRICTION LOSS = 5 GPM MAX SUMP DISCHARGE = 50 GPM

REQUIRED SUMP PIT SIZE: 35.09 CUBIC FT. SIDE "A" = 44 IN SIDE "B" = 92 IN DEPTH = 16 IN



TYPICAL CHEMICAL ROOM SHELVING w/ QUANTITIES A. Unless otherwise stated, all code references are to the 2018 North Carolina State Building Codes (NCSBC).



4 Enlarged Pump Room 1/2" = 1'-0"

2 Detail - Sump Pit 1/2" = 1'-0"

1 Detail - Chemical Storage 1/2" = 1'-0"

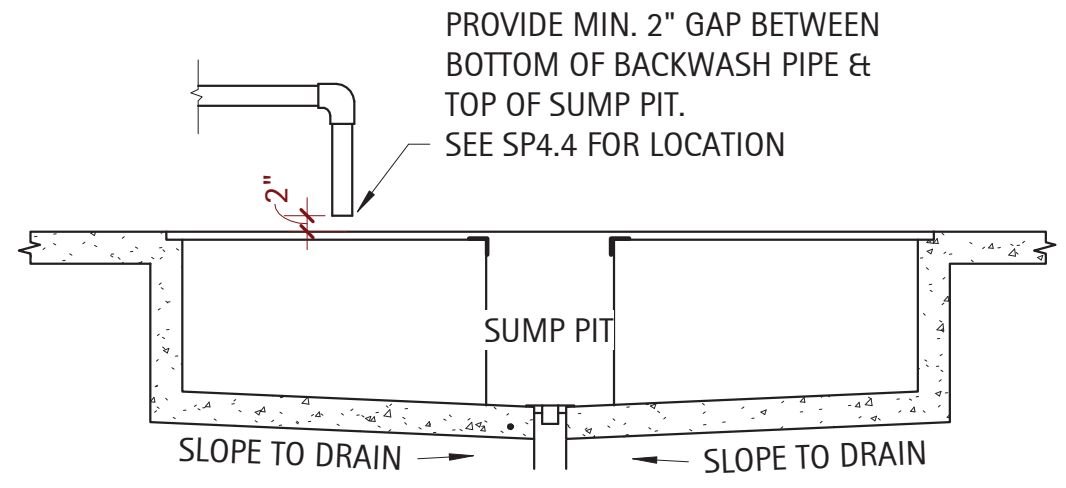
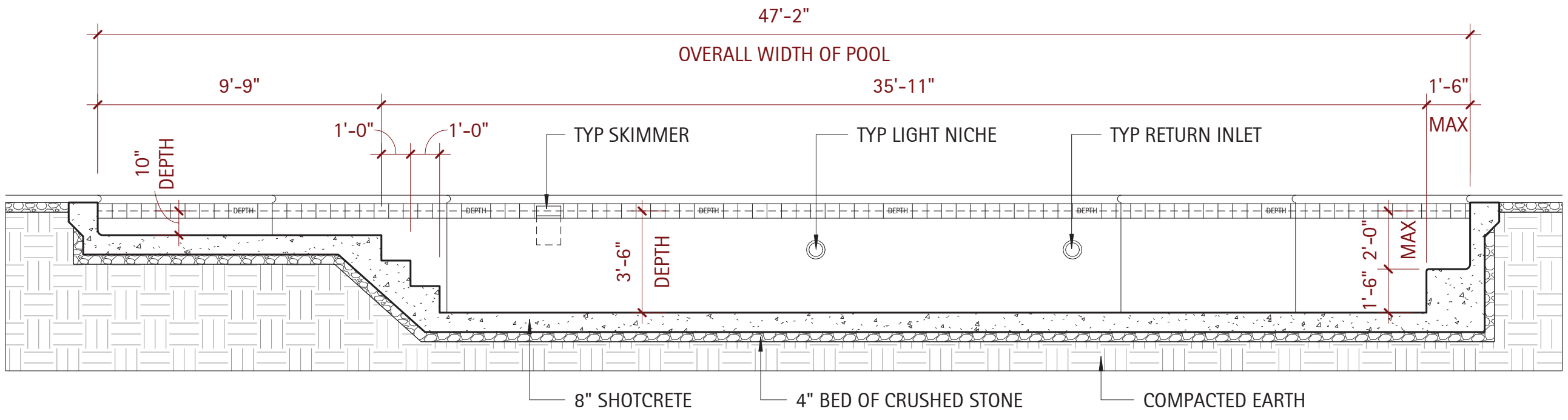

5 Detail - North South Pool Section 1/4" = 1'-0"

3 Detail - 2" Air Gap 1/2" = 1'-0"

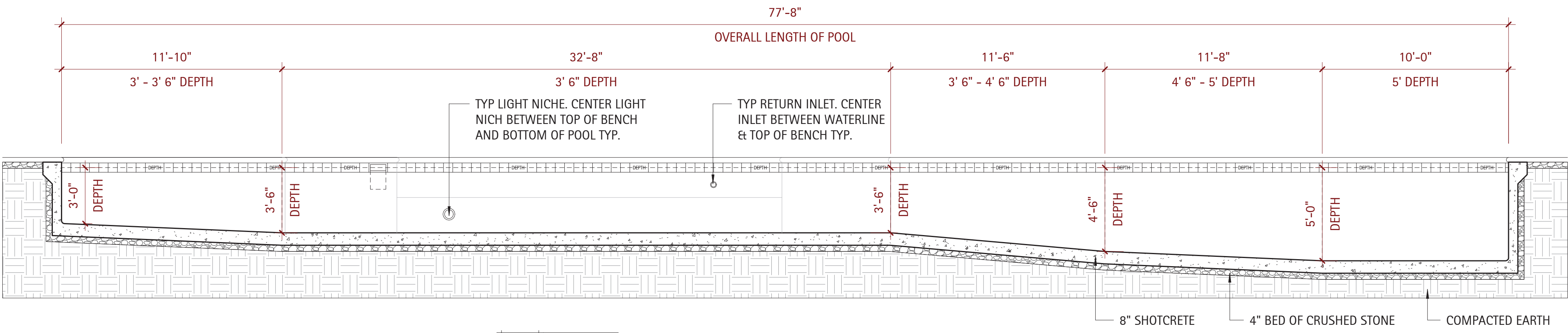

6 Detail - East West Pool Section 1/4" = 1'-0"

MAIN POOL DATA table with columns: POOL DIMENSIONS, POOL DEPTHS, POOL VOLUME, SURFACE AREA, PERIMETER, COPING, REQUIRED FLOW, DESIGN FLOW, SHELL MATERIAL, INTERIOR FINISH, BATHER LOAD, BACKWASH TO, WATER SOURCE, PIPE SIZING, SKIMMERS, VACUUM LINE, INLETS, FILTER TYPE, SIZE PROVIDED, SIZE REQUIRED, MEDIA CIRC. RATE, BACKWASH RATE, TURNOVER RATE

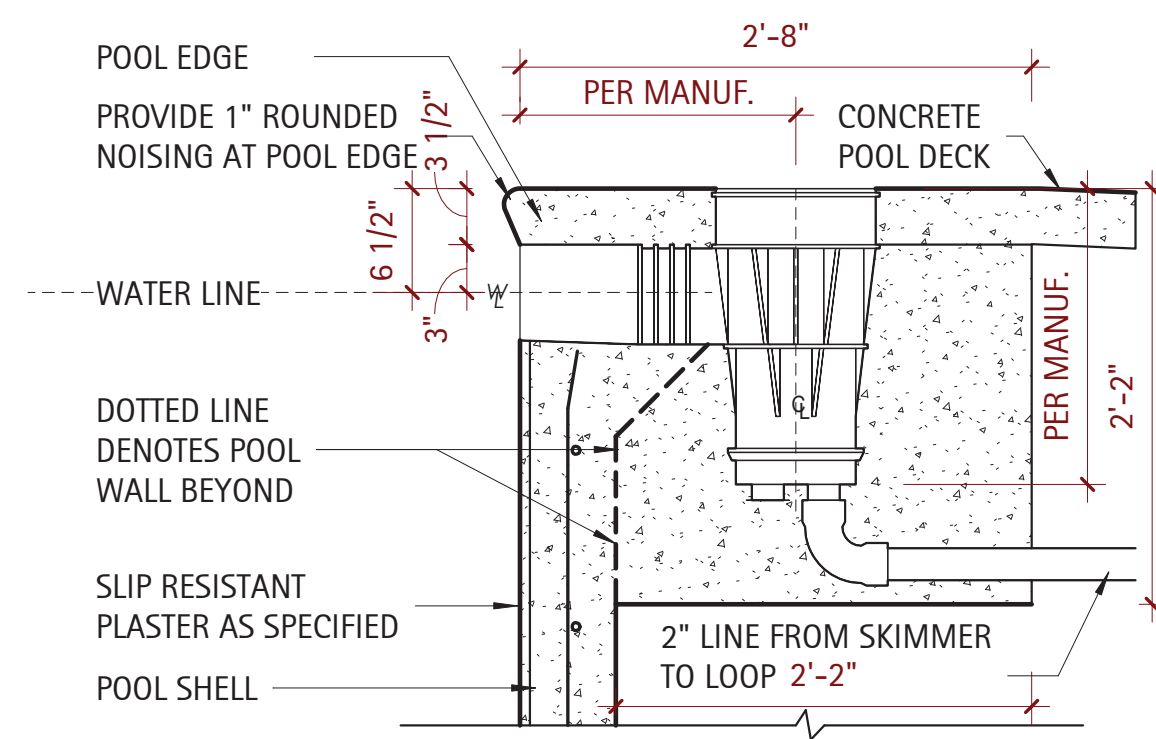

7 Detail - Pool Skimmer
1" = 1'-0"

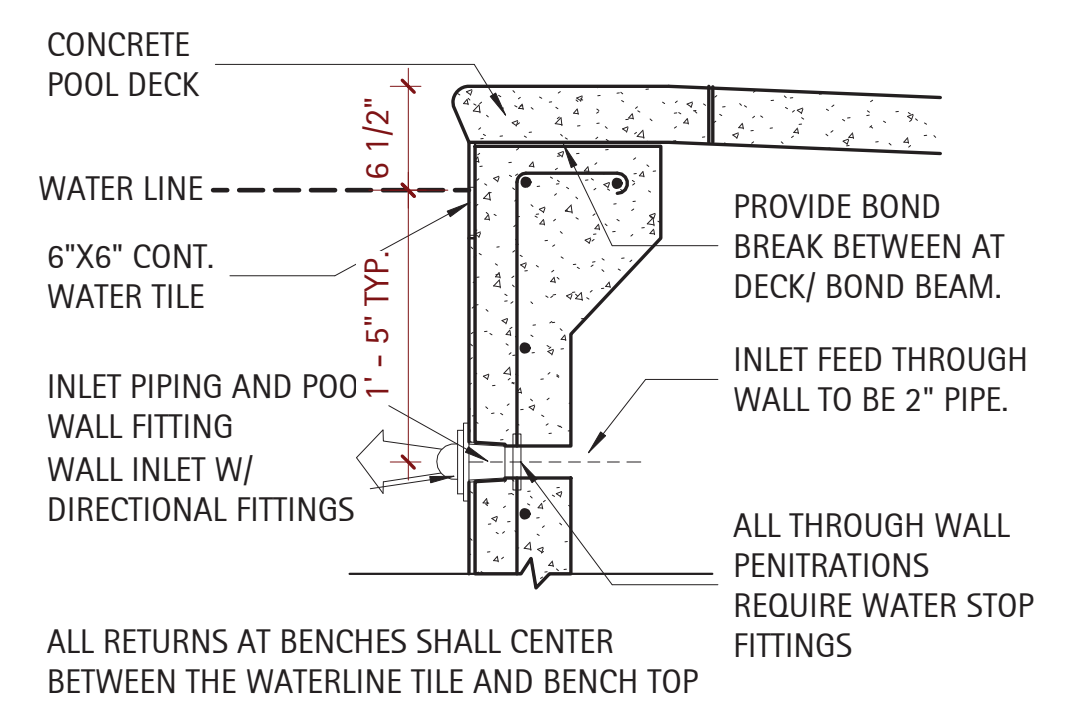

8 Detail - Return Inlet Pipe
1" = 1'-0"

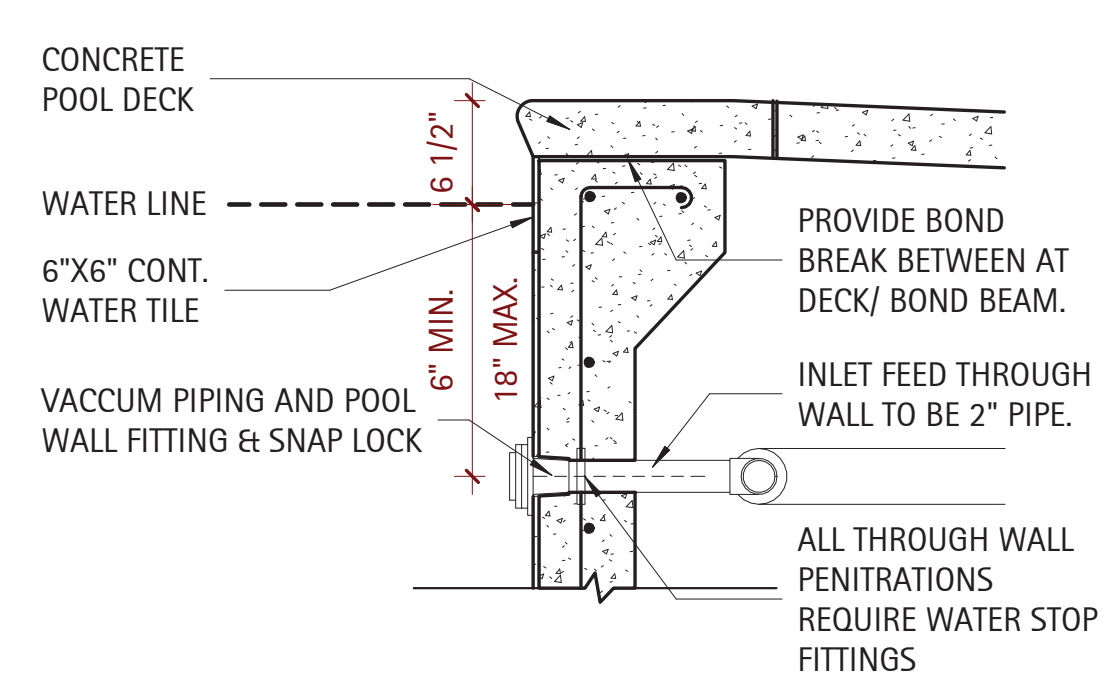

9 Detail - Vacuum Inlet
1" = 1'-0"

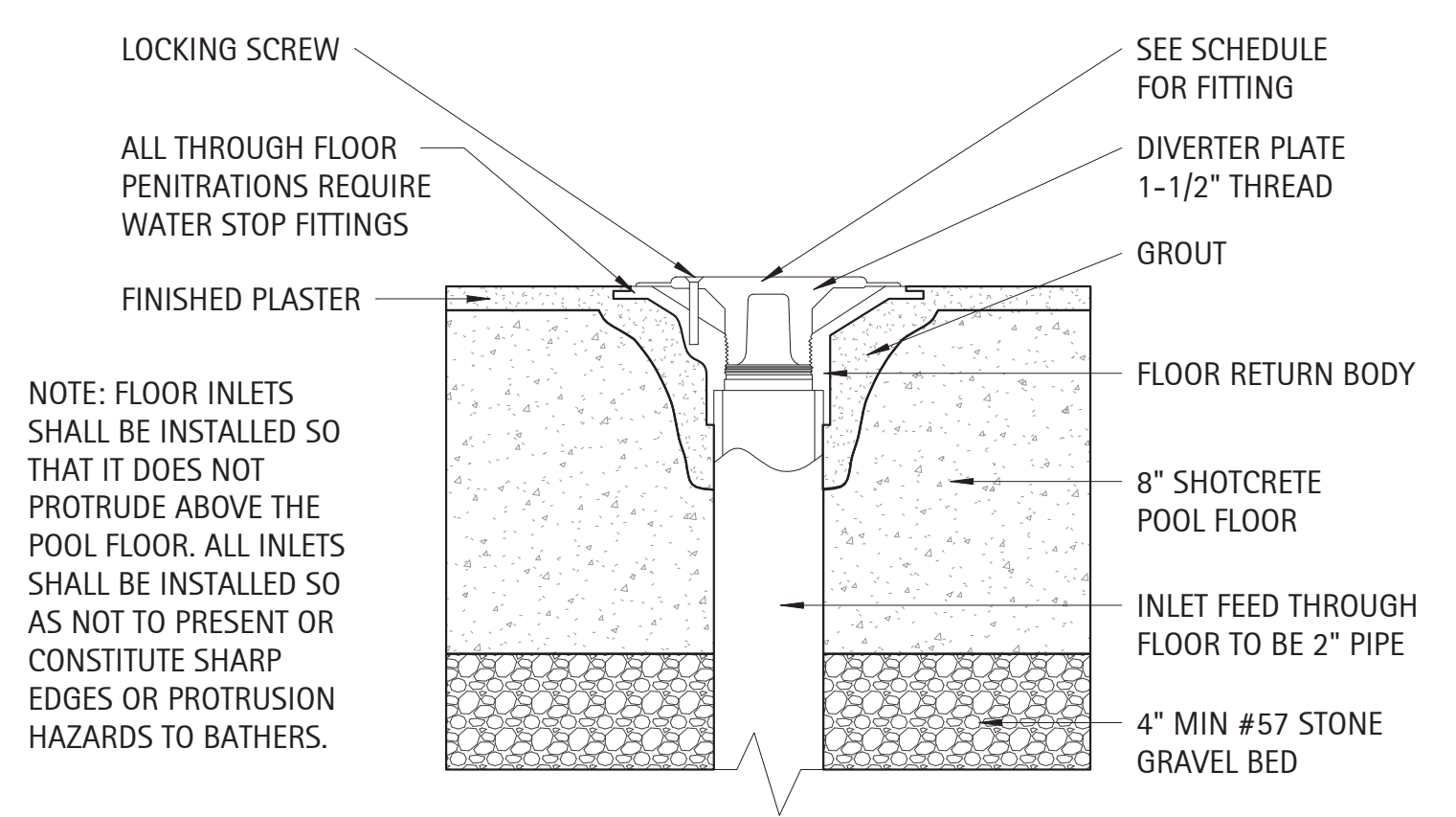

10 Detail - Floor Inlet Pipe
3" = 1'-0"

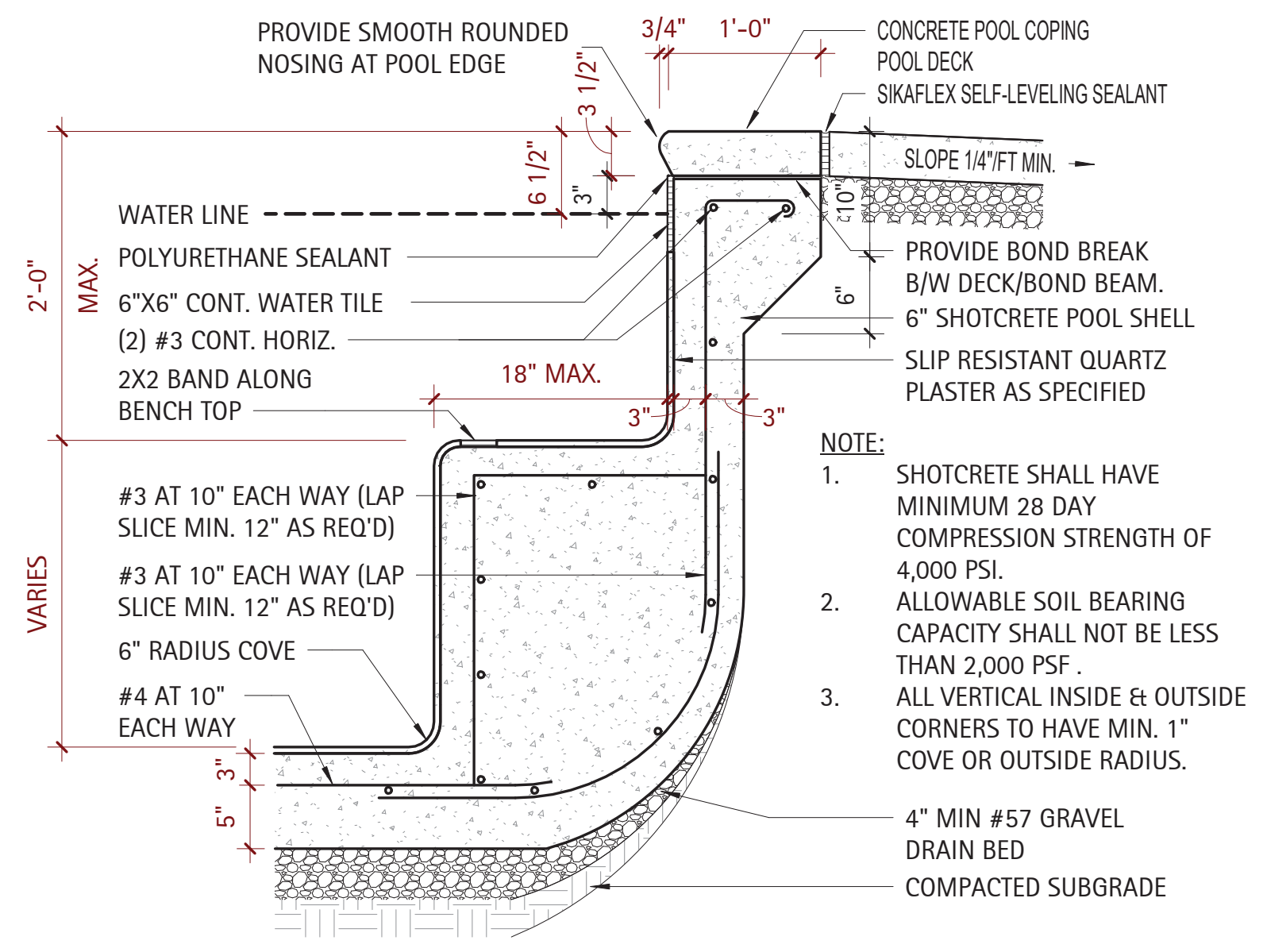

6 Detail - Pool Bonding
1" = 1'-0"

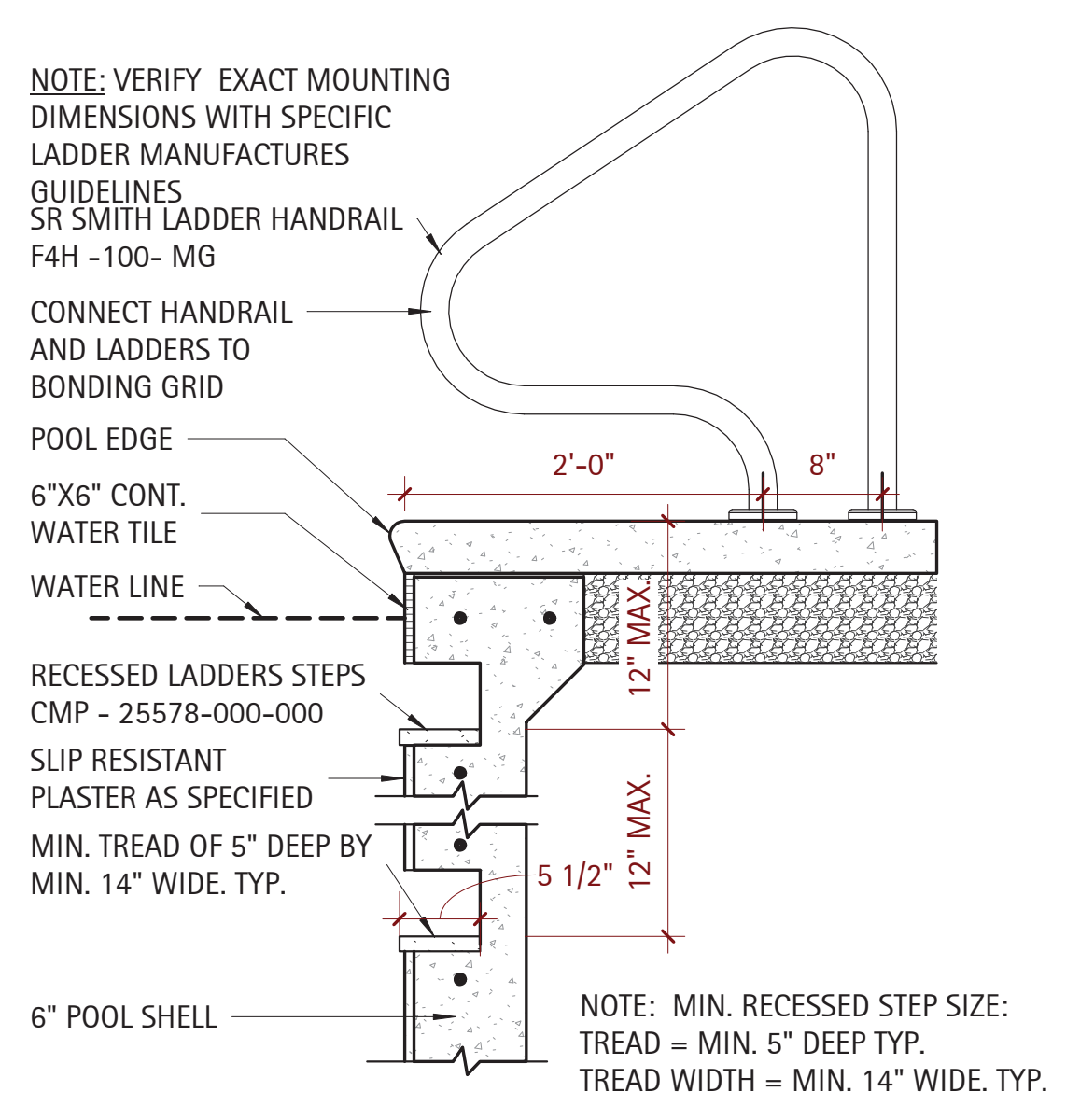

4 Detail - Pool Bench
1" = 1'-0"

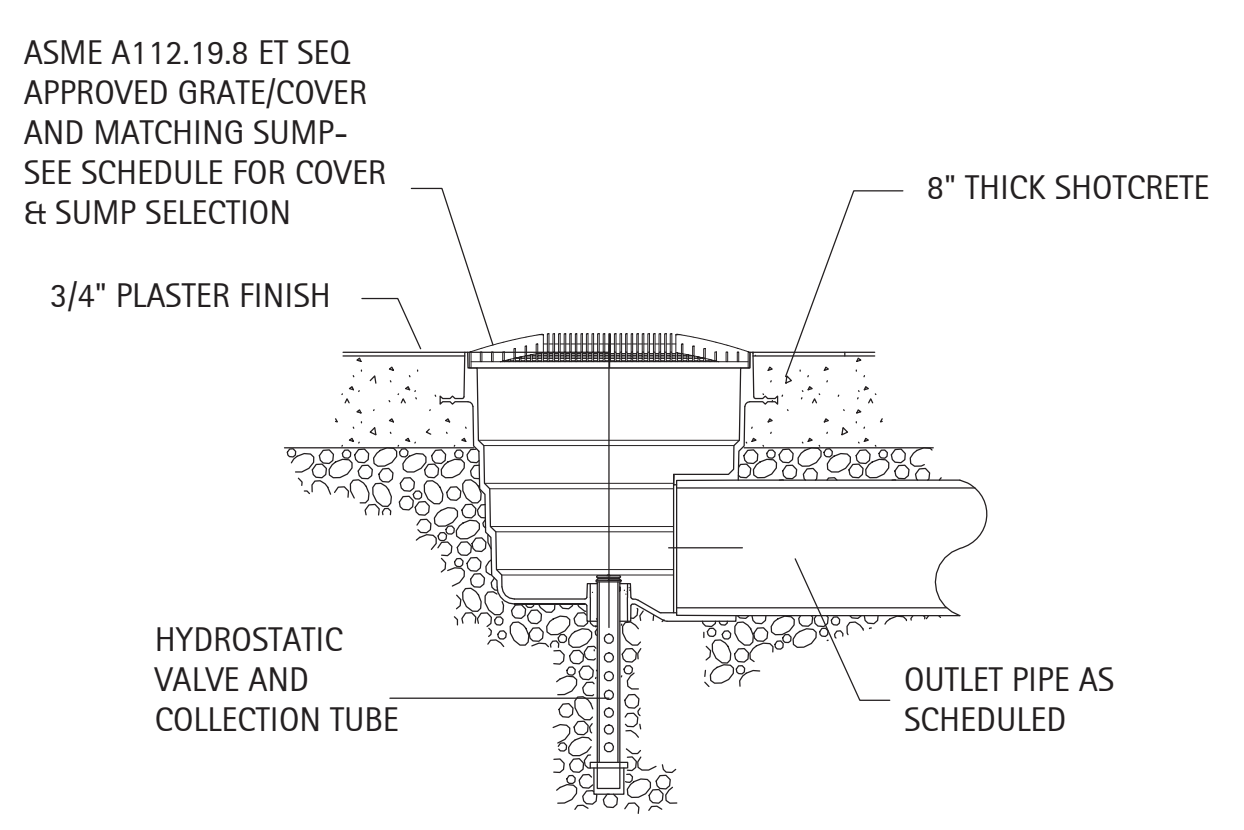

5 Detail - Main Drain
1" = 1'-0"

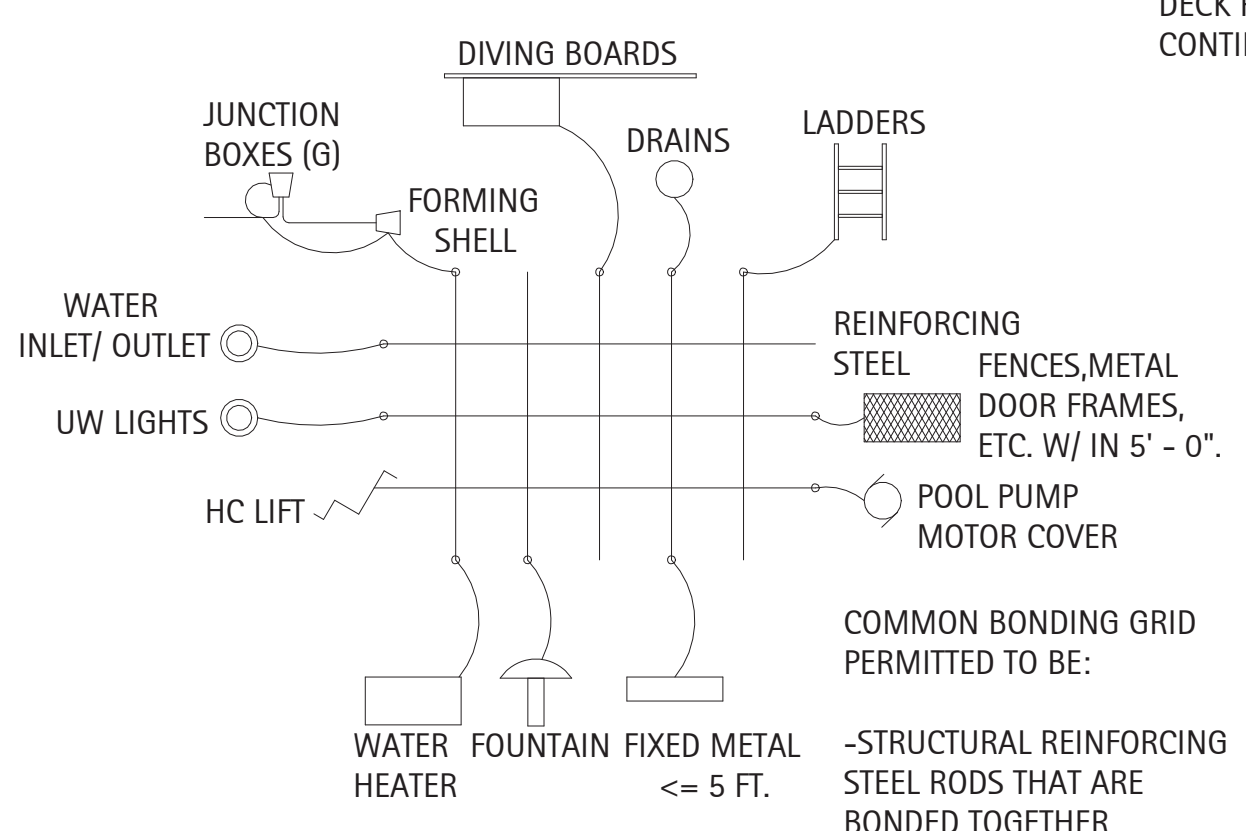

SWIMMING POOL BONDING RISER

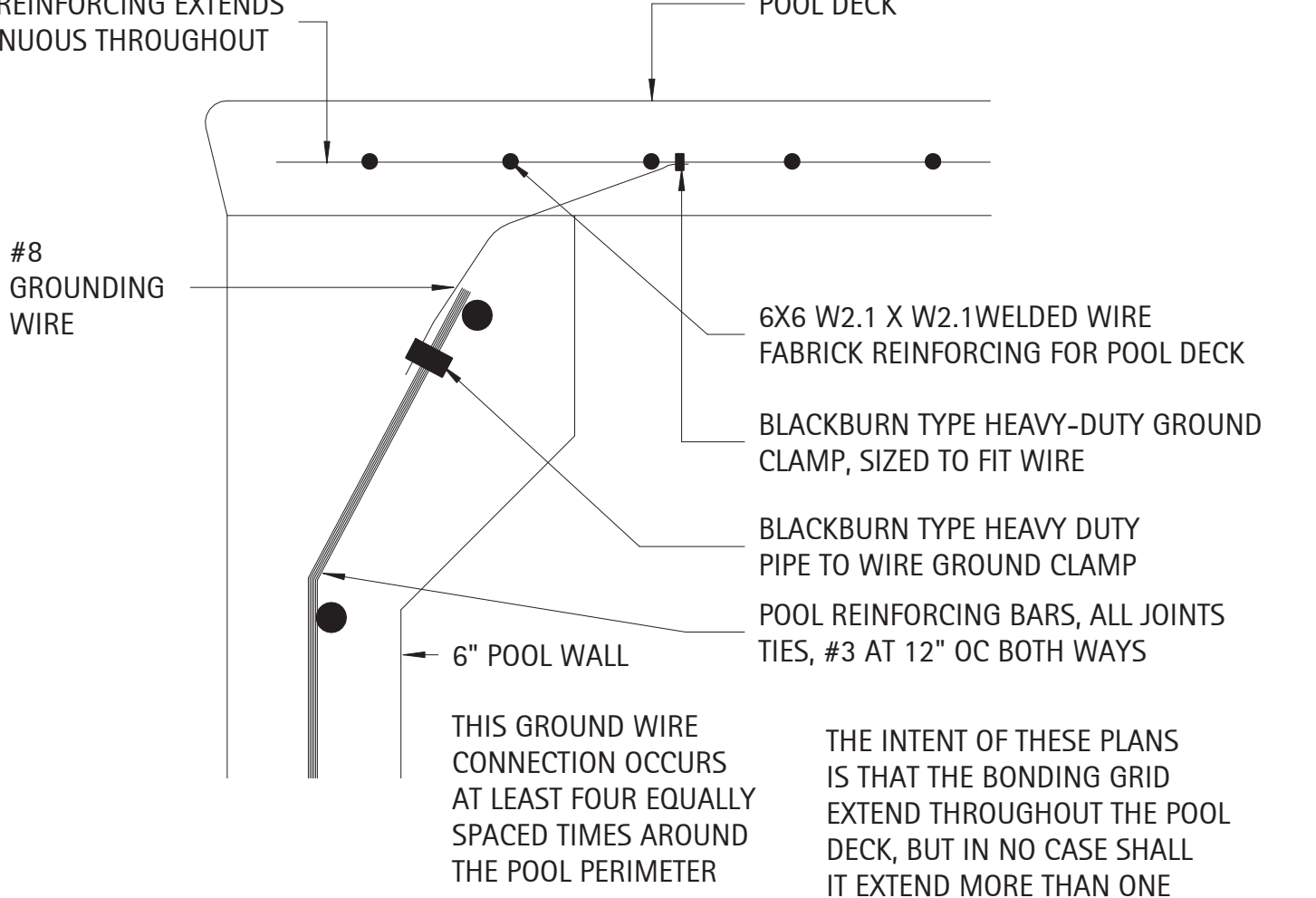

EQUIPOTENTIAL BONDING GRID DETAIL

1 Detail - Pool Bonding
1" = 1'-0"

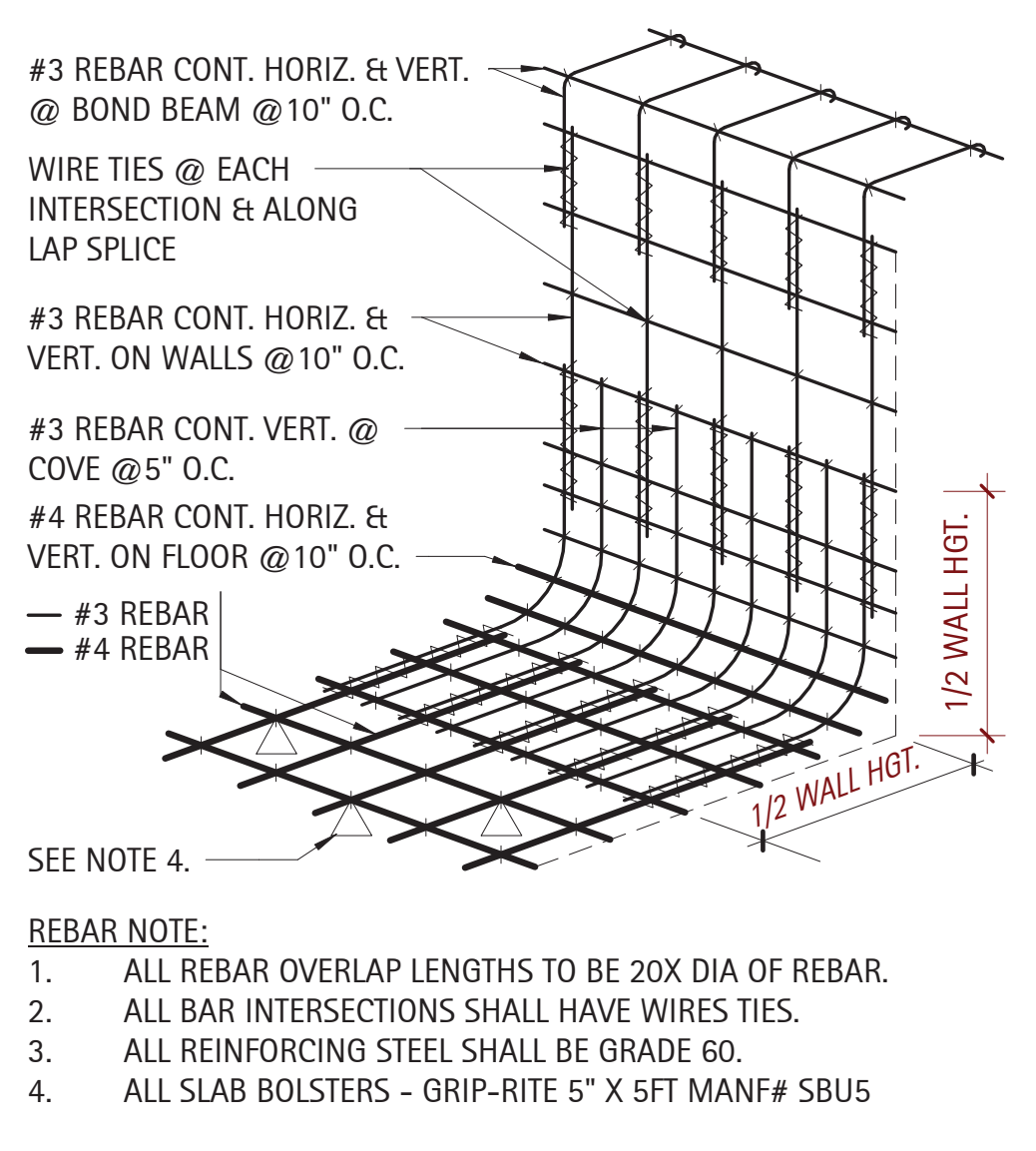

2 Detail - Pool Wall
1" = 1'-0"

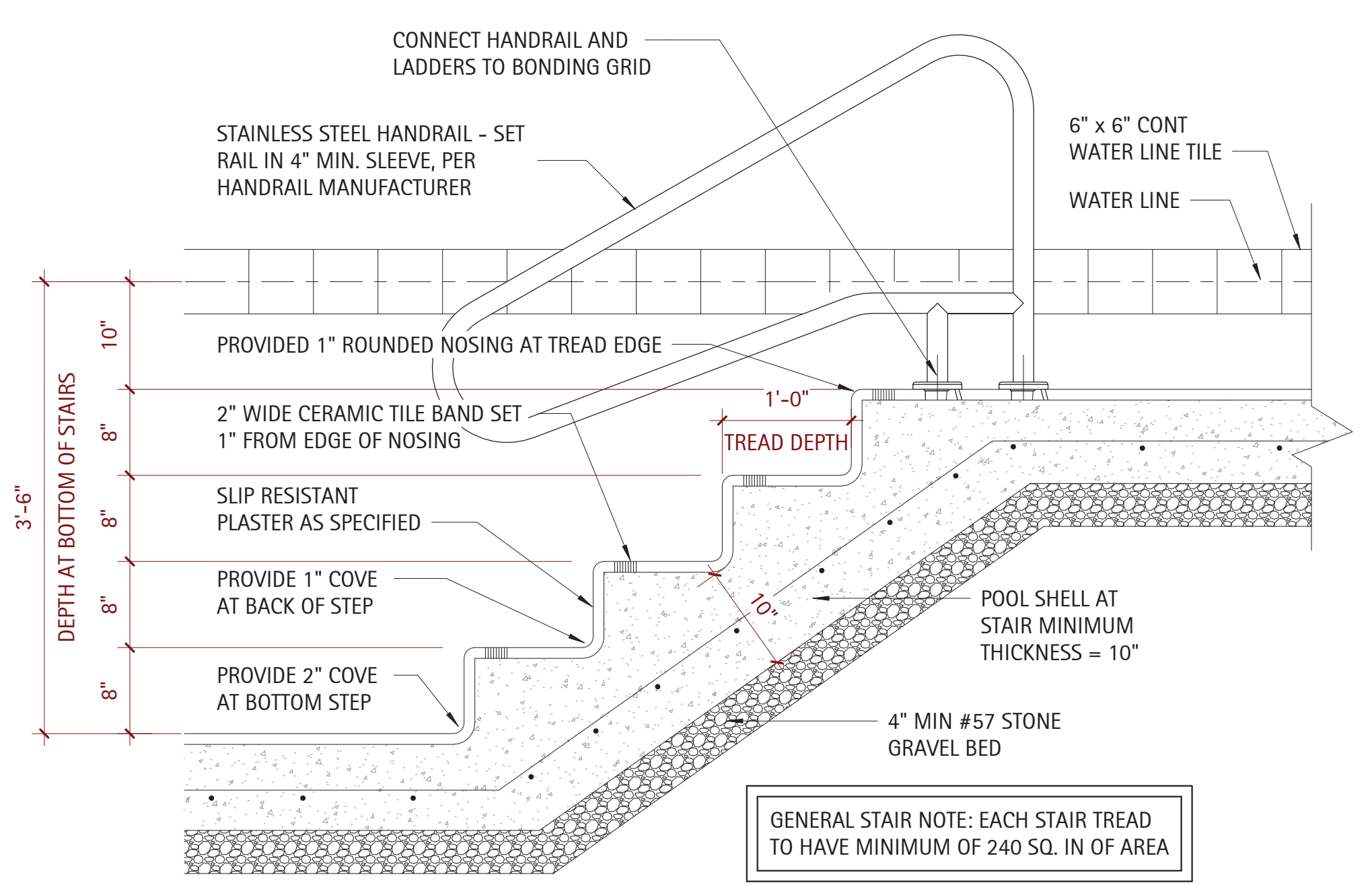
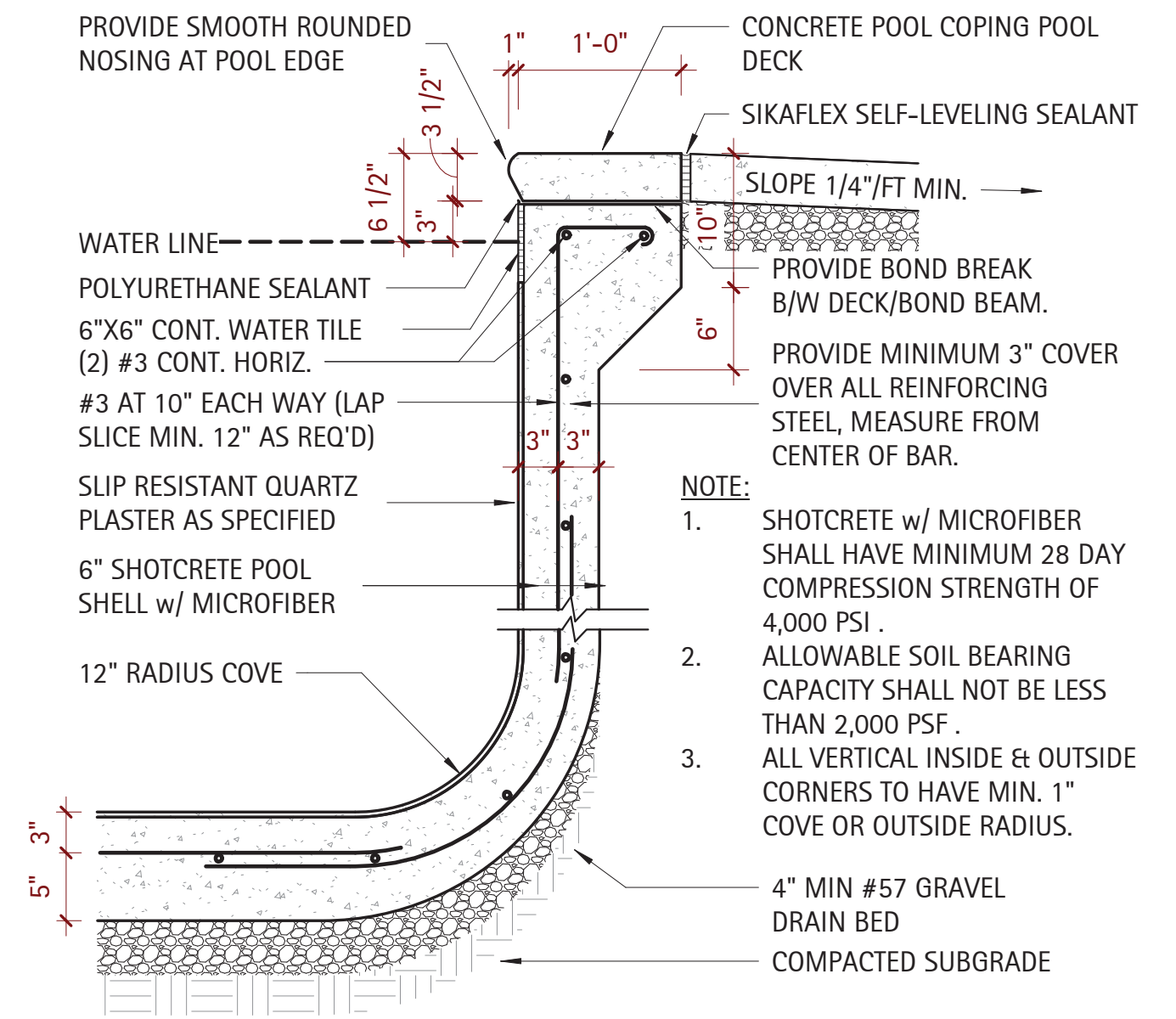

3 Detail - Pool Shelf Steps
1" = 1'-0"

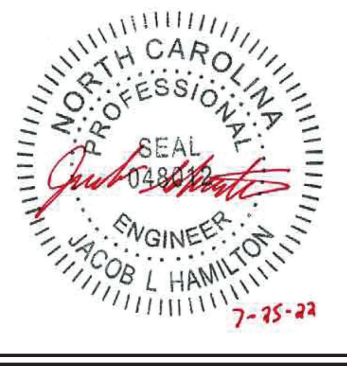

NO.	REVISION	DATE

SHEET DISCUSSION
Sections & Details

PROJECT #:	2022002
DATE ISSUED:	07/20/2022
DRAWING BY:	JVD
CHECKED BY:	DSC/JLH

**WOODGROVE
DR HORTON
BATHHOUSE & POOL
HARNETT COUNTY, NC**



TriStar
High Efficiency Pumps
THE INDUSTRY'S MOST
HYDRAULICALLY EFFICIENT PUMP

DO MORE, WITHOUT PAYING FOR MORE.

When it comes to performance and value, nothing beats Hayward TriStar pumps. With best-in-class hydraulic technology, they outpace competing pumps—even those with higher horsepower. Add to that a service-friendly design and an easy-clean debris basket, and it's no wonder TriStar pumps continue to set the industry standard for efficiency and value.

KEY FEATURES

- Superior hydraulic efficiency delivers higher performance at lower horsepower
- Extra-large, no-rib debris basket offers greater capacity for less frequent maintenance
- Standard union connections (2" x 2.5") make installation and servicing fast and easy
- Self-priming design offers suction lift up to 10' above waterline



SPECIFICATIONS

MODEL NUMBER	TOTAL HORSEPOWER	VOLTAGE	UNION CONNECTIONS	DIMENSION "A"	WEIGHTED ENERGY FACTOR (WEF)*
SP3200X10	1.1	115/208-230	2" x 2 1/2"	13 1/2"	4.0
SP3250EE	5.0	208-230	2" x 2 1/2"	17 1/2"	1.7

*The higher the weighted energy factor (WEF), the more efficient the pump. Visit hayward.com for more information.

TRISTAR SERIES DIMENSIONS (INCHES)

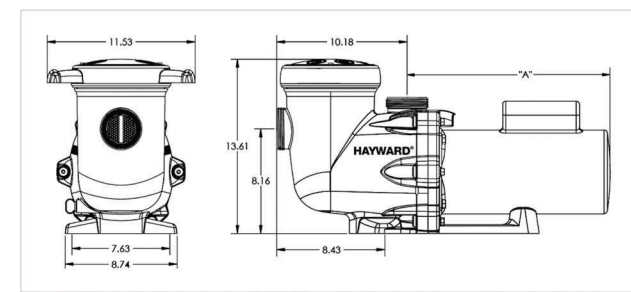

TRISTAR FLOW VS. TOTAL HEAD

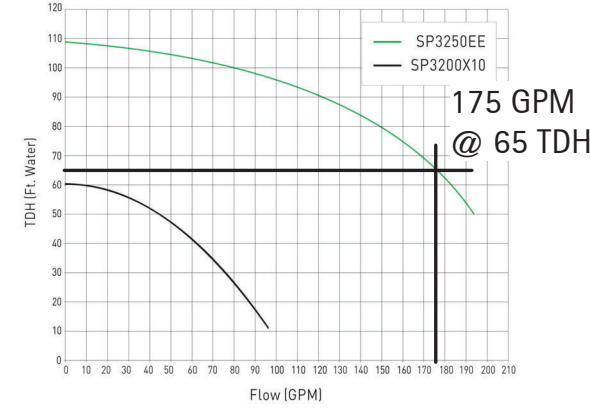

TriStar pumps are listed by: NSF, IAPMO, ETL. hayward.com • 1-888-HAYWARD • Pumps • Filters • Heaters • Sanitization • Automation • Lighting • Water Features • Cleaners • Safety. Hayward, Hayward & Design, the H logo and TriStar are registered trademarks and We Build Better is a trademark of Hayward Industries, Inc. All other trademarks not owned by Hayward are the property of their respective owners. Hayward is not in any way affiliated with or endorsed by these third parties. © 2021 Hayward Industries, Inc. 4/17/2021/04/21

Valve & Filter Connection Guide

	PENTAIR	STA-RITE	XF FILTERS																																						
Filter Inlet - BOTTOM	P/N 263081	P/N 262508	P/N 262512																																						
	<table border="1"> <tr><th>Filter P/N</th><th>Pentair Filters</th></tr> <tr><td>180006</td><td>FNS Plus FNSP24</td></tr> <tr><td>180007</td><td>FNS Plus FNSP36</td></tr> <tr><td>180008</td><td>FNS Plus FNSP48</td></tr> <tr><td>180009</td><td>FNS Plus FNSP60</td></tr> </table>	Filter P/N	Pentair Filters	180006	FNS Plus FNSP24	180007	FNS Plus FNSP36	180008	FNS Plus FNSP48	180009	FNS Plus FNSP60	<table border="1"> <tr><th>Filter P/N</th><th>Sta-Rite Filters</th></tr> <tr><td>S7D75</td><td>System 3 DE Filter</td></tr> <tr><td>S8D110</td><td>System 3 DE Filter</td></tr> <tr><td>S7S50</td><td>System 3 Sand Filter</td></tr> <tr><td>S8S70</td><td>System 3 Sand Filter</td></tr> </table>	Filter P/N	Sta-Rite Filters	S7D75	System 3 DE Filter	S8D110	System 3 DE Filter	S7S50	System 3 Sand Filter	S8S70	System 3 Sand Filter	<table border="1"> <tr><th>Filter P/N</th><th>XF Filters</th></tr> <tr><td>188626</td><td>XF Q-60 DE</td></tr> <tr><td>188618</td><td>XF F-36 DE</td></tr> <tr><td>188619</td><td>XF Q-80 DE</td></tr> <tr><td>188620</td><td>XF F-48 DE</td></tr> <tr><td>188621</td><td>XF Q-100 DE</td></tr> <tr><td>188622</td><td>XF F-60 DE</td></tr> <tr><td>188623</td><td>XF Q-120 DE</td></tr> <tr><td>188624</td><td>XF F-72 DE</td></tr> </table>	Filter P/N	XF Filters	188626	XF Q-60 DE	188618	XF F-36 DE	188619	XF Q-80 DE	188620	XF F-48 DE	188621	XF Q-100 DE	188622	XF F-60 DE	188623	XF Q-120 DE	188624	XF F-72 DE
Filter P/N	Pentair Filters																																								
180006	FNS Plus FNSP24																																								
180007	FNS Plus FNSP36																																								
180008	FNS Plus FNSP48																																								
180009	FNS Plus FNSP60																																								
Filter P/N	Sta-Rite Filters																																								
S7D75	System 3 DE Filter																																								
S8D110	System 3 DE Filter																																								
S7S50	System 3 Sand Filter																																								
S8S70	System 3 Sand Filter																																								
Filter P/N	XF Filters																																								
188626	XF Q-60 DE																																								
188618	XF F-36 DE																																								
188619	XF Q-80 DE																																								
188620	XF F-48 DE																																								
188621	XF Q-100 DE																																								
188622	XF F-60 DE																																								
188623	XF Q-120 DE																																								
188624	XF F-72 DE																																								
Filter Inlet - TOP	P/N 263080	P/N 262507																																							
	<table border="1"> <tr><th>Filter P/N</th><th>Pentair Filters</th></tr> <tr><td>188592</td><td>Quad DE 60</td></tr> <tr><td>188593</td><td>Quad DE 80</td></tr> <tr><td>188594</td><td>Quad DE 100</td></tr> <tr><td>140212</td><td>TR 60 Sand</td></tr> <tr><td>140236</td><td>TR 40 Sand</td></tr> <tr><td>140249</td><td>TR 50 Sand</td></tr> </table>	Filter P/N	Pentair Filters	188592	Quad DE 60	188593	Quad DE 80	188594	Quad DE 100	140212	TR 60 Sand	140236	TR 40 Sand	140249	TR 50 Sand	<table border="1"> <tr><th>Filter P/N</th><th>Pentair Filters</th></tr> <tr><td>140264</td><td>TR 60 Sand</td></tr> <tr><td>140210</td><td>TR 100 Sand</td></tr> <tr><td>140243</td><td>TR 140 Sand</td></tr> <tr><td>140335</td><td>TR 100 HD</td></tr> <tr><td>140315</td><td>TR 100C Sand</td></tr> <tr><td>140316</td><td>TR 140C Sand</td></tr> </table>	Filter P/N	Pentair Filters	140264	TR 60 Sand	140210	TR 100 Sand	140243	TR 140 Sand	140335	TR 100 HD	140315	TR 100C Sand	140316	TR 140C Sand	<table border="1"> <tr><th>Filter P/N</th><th>Sta-Rite Filters</th></tr> <tr><td>PLDE 36</td><td>System 2 Mod DE</td></tr> <tr><td>PLDE48</td><td>System 2 Mod DE</td></tr> <tr><td>STMD60</td><td>System 3 Mod DE</td></tr> <tr><td>STMD72</td><td>System 3 Mod DE</td></tr> </table>	Filter P/N	Sta-Rite Filters	PLDE 36	System 2 Mod DE	PLDE48	System 2 Mod DE	STMD60	System 3 Mod DE	STMD72	System 3 Mod DE
Filter P/N	Pentair Filters																																								
188592	Quad DE 60																																								
188593	Quad DE 80																																								
188594	Quad DE 100																																								
140212	TR 60 Sand																																								
140236	TR 40 Sand																																								
140249	TR 50 Sand																																								
Filter P/N	Pentair Filters																																								
140264	TR 60 Sand																																								
140210	TR 100 Sand																																								
140243	TR 140 Sand																																								
140335	TR 100 HD																																								
140315	TR 100C Sand																																								
140316	TR 140C Sand																																								
Filter P/N	Sta-Rite Filters																																								
PLDE 36	System 2 Mod DE																																								
PLDE48	System 2 Mod DE																																								
STMD60	System 3 Mod DE																																								
STMD72	System 3 Mod DE																																								

FullFloXF™ Backwash Valve Installation and User's Guide

**TRITON™ C SERIES
COMMERCIAL SAND FILTERS**

TRITON HD FILTER

The Triton heavy duty (HD) filter is a thirty-inch fiberglass filter that offers a maximum operating pressure of 75 PSI. This filter is specifically designed for special high-pressure commercial applications that require up to 98 gpm, and is ideal for all heavy-duty commercial applications.

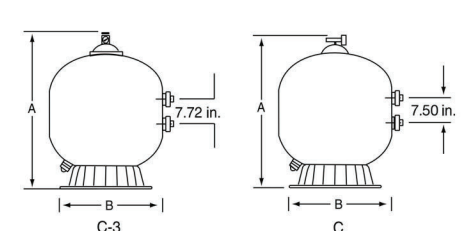

Model Number	Filter Area Sq. Ft.	Flow Rate 15 GPM/Inq. Ft.*	Turnover Capacity Gallons 4 Hours	8 Hours	Dimension A	B	Media Required Sand	Sand/Drain
TR100C	4.47	76	26,460	52,920	39 1/2"	30 1/2"	490 lbs./150 lbs.	490 lbs./150 lbs.
TR140C	7.06	106	38,160	76,320	45 1/2"	36 1/2"	920 lbs./275 lbs.	920 lbs./275 lbs.
TR180C-3	9.91	141	46,460	92,920	52 1/2"	42 1/2"	1,400 lbs./430 lbs./175 lbs.	1,400 lbs./430 lbs./175 lbs.
TR140C-3	7.06	106	38,160	76,320	45 1/2"	36 1/2"	920 lbs./275 lbs.	920 lbs./275 lbs.

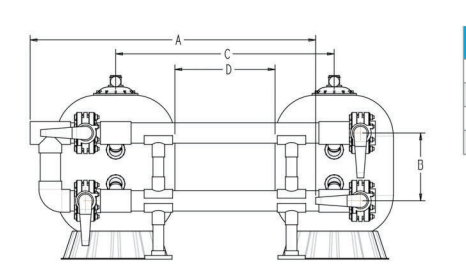

Two Filter System	A	B	C	D	Total Wt.
3" - TR100C	82 1/2"	17 1/2"	48" Min.	18" Min.	2,300 lbs.
3" - TR140C	88 1/2"	17 1/2"	54" Min.	18" Min.	3,200 lbs.
4" - TR140C	92 1/2"	19 1/2"	54" Min.	18" Min.	2,300 lbs.
4" - TR140C	111 1/2"	24 1/2"	54" Min.	18" Min.	3,550 lbs.

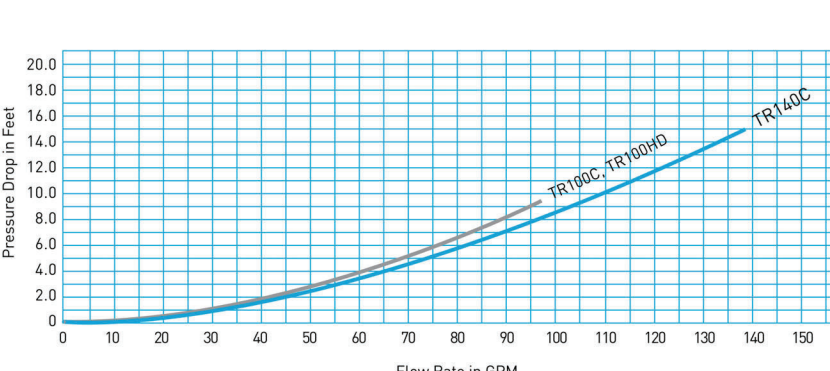

PENTAIR
1620 HAWKINS AVE., SANFORD, NC 27330 800.831.7133 WWW.PENTAIRCOMMERCIAL.COM
All Pentair trademarks and logos are owned by Pentair, Inc. Triton™ is a registered trademark of Pentair Water Pool and Spa, Inc. and/or its affiliated companies in the United States and/or other countries. Because we are continuously improving our products and services, Pentair reserves the right to change specifications without prior notice. Pentair is an equal opportunity employer.
1/13 Part # P1-151 ©2013 Pentair Water Pool and Spa, Inc. All rights reserved.

**RAINBOW™
HIGH CAPACITY CHLORINE/
BROMINE FEEDERS**

- Designed for ease of use and simple maintenance
- Drain valve allows easier draining for safer recharging or winterizing
- Standard threaded inlet and outlet fittings included for easy installation



THE PERFORMANCE LEADER IN AUTOMATIC SANITIZATION FOR LARGE RESIDENTIAL AND COMMERCIAL POOLS

The INLET control valve side of the feeder connects to the plumbing on the discharge side of the pump, before the filter. The OUTLET side of the feeder connects to the pool return line after the filter and/or heater, pool cleaner, diverter valves, or any other installed equipment. Installation of a corrosion-resistant check valve such as #R172288 by Pentair between the feeder inlet and outlet and the equipment is strongly recommended to check backflow of chemicals. This helps ensure equipment longevity.

AVAILABLE FROM:



1620 HAWKINS AVE., SANFORD, NC 27330 800.831.7133 WWW.PENTAIRPOOL.COM
All Pentair trademarks and logos are owned by Pentair, Inc. Rainbow™ is a trademark of Pentair Water Pool and Spa, Inc. and/or its affiliated companies in the United States and/or other countries. Because we are continuously improving our products and services, Pentair reserves the right to change specifications without prior notice. Pentair is an equal opportunity employer.
pumps • filters • heaters • heat pumps • automation • lighting • cleaners • sanitizers • water features • maintenance products
1/14 Part # RS-1012 ©2014 Pentair Water Pool and Spa, Inc. All rights reserved.

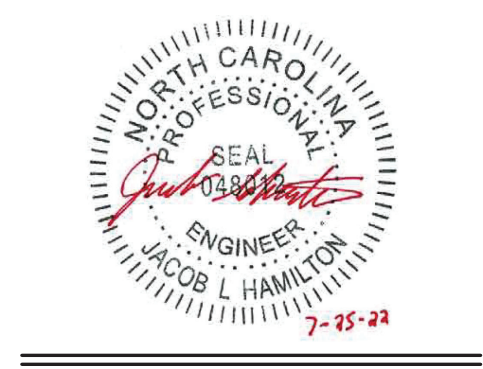

Kilian Engineering, Inc.
PO Box 3301, Healdston, NC 27536 | www.kilianengineering.com
(919) 458-8778 | CORPORATE LICENSE C-2277

TAG 1 - CIRCULATION PUMP - SP3250EE - 5 HP HIGH EFFICIENCY PUMP

TAG 2 - BACKWASH VALVE - P/N 260080 & FILTER P/N 140316

TAG 3 - SAND FILTER - TR140-C3 - HIGH RATE SAND FILTER

TAG 4 - CHLORINATOR - HC3315 - HIGH CAPACITY CHLORINE/BROMINE FEEDER

WHEN ACCURACY IS CRITICAL, DON'T JUST TAKE OUR WORD FOR IT!

FlowVis® was the first - and is now the most - NSF 50 certified flow meter in the world! Because when accuracy matters, you should put your trust in the experts.

NSF
NSF-50 CERTIFIED L1

FLOWVIS® MODELS

Feature	FW-15	FW-15-U	FW-15	FW-2-U	FW-25	FW-3	FW-3-40	FW-4	FW-6	FW-8
NSF 50 Certified	✓	✓	✓	✓	✓	✓	✓	✓	✓	✓
Pipe Size	1.5"	1.5"	2"	2"	2.5"	3"	3"	4"	6"	8"
Operating Range (GPM)	10-80	10-90	10-100	10-100	10-100	70-240	70-240	150-460	300-1000	600-1800
Average Accuracy	98.7%	98.7%	99.4%	99.0%	99.2%	98.9%	99.2%	99.6%	98.7%	N/A*
NSF 50 Level	L1	L1	L1	L1	L1	L1	L1	L1	L1	L1

*FlowVis® model FW-8 is available only with FlowVis® Digital upgrade included. For accuracy of this model, refer to the FW-8 information in the FlowVis Digital table below.

FLOWVIS® DIGITAL MODELS

Feature	FW-15	FW-15-U	FW-2	FW-2-U	FW-25	FW-3	FW-3-40	FW-4	FW-6	FW-8
NSF 50 Certified	✓	✓	✓	✓	✓	✓	✓	✓	✓	✓
Pipe Size	1.5"	1.5"	2"	2"	2.5"	3"	3"	4"	6"	8"
Operating Range (GPM)	10-80	10-90	10-100	10-100	10-100	70-240	70-240	150-460	300-1000	600-1800
Average Accuracy	98.6%	99.0%	98.8%	98.5%	98.3%	98.4%	98.0%	98.3%	98.9%	98.9%
NSF 50 Level	L1	L1	L1	L1	L1	L1	L1	L1	L1	L1

NOTE: FlowVis is the only NSF 50 certified Level 1 flow meter in the world today.

Guide for NSF 50 Accuracy Levels

Level 1 (L1): Average of absolute values of all single point deviations must be <=2%. Single point deviations shall not exceed <=4%.

Level 2 (L2): Average of absolute values of all single point deviations must be <=5%. Single point deviations shall not exceed <=7.5%.

Level 3 (L3): Average of absolute values of all single point deviations must be <=10%. Single point deviations shall not exceed <=12.5%.

Level 4 (L4): Average of absolute values of all single point deviations must be <=15%. Single point deviations shall not exceed <=15%.

Level 5 (L5): Average of absolute values of all single point deviations must be <=15%. Single point deviations shall not exceed <=20%.

9" SQUARE MOFLOW™ SUCTION OUTLET COVER AND MUD FRAME

VGB CERTIFIED SPECIFICATIONS	Floor Flow Rating	Wall Flow Rating	Sump Depth	Open Area
	258 GPM at 2.3 fps	274 GPM at 2.4 fps	3" minimum	36.8 in²

FEATURES

- All components meet or exceed ANSI/APSP 16-2011 and NSF/ANSI 50-2009a national standards and ASTM G154 UV testing exposure
- Easily and safely retrofits to 9" square 1/2" deep frames
- Manufactured from superior UV-resistant engineered polymers
- #316 stainless steel covers
- Trademarked VGB compliance button easily identifies VGB 2008 compliant cover from on deck and underwater
- Online product support including downloadable CAD files, General Certificate of Conformity, third-party certificate, installation instructions and more
- Replace drain cover every five years from the date of installation
- See next page for additional product configurations
- 8 per case

STANDARD COLORS

- SMF101 - White
- SMF102 - Black
- SMF103 - Light Gray
- SMF104 - Blue
- SMF105 - Dark Gray
- SMF106 - Tan

Replaces p/n 9900, P9900, SRF5900, SUR9900, SUN9900, WAW9900, WAW9900

VGB 2008 Compliant

Part # 9MFxxx
Fits: AquaStar 9" standard models and American (Pentair) with 1/2" deep existing frames and four screw hole pattern.

1. 9" Square Mud Frame
2. 10 x 3/4" Flat Head Phillips, 316 SS, Qty 4

P 877-768-2717 F 877-276-POOL Outside the US: P +1-949-336-1940 F +1-949-336-1940
info@aquastarpoolproducts.com www.aquastarpoolproducts.com

AQUASTAR Hydrstatic Relief Valves

Self-Contained Hydrostatic Valve Assembly

Part # HVCxxx

FEATURES

- Self-contained unit has a built-in collector tube
- Installs directly into the pool finish with no additional plumbing connection required
- Helps prevent swimming pool damage due to hydrostatic pressure beneath the pool shell when the pool is drained

12 per case

HVC05xxx - Cap and Screws

STANDARD COLORS

- HVC101
- HVC102
- HVC103
- HVC104
- HVC105
- HVC108

2" Hydrostatic Relief Valve

Part # HVxxx

FEATURES

- Equalizes pressure for high water tables
- Fins enable easy twist for installation and removal
- Fits any AquaStar and most other manufacturers' 2" threads
- Manufactured from superior UV-resistant engineered polymers
- Includes 2" x 1 1/2" reducer bushing
- Reducer bushing must be glued into hydrostatic relief valve using ABS glue

25 per case

STANDARD COLORS

- HV101
- HV102
- HV103
- HV104
- HV105
- HV108

P 877-768-2717 F 877-276-POOL Outside the US: P +1-805-620-5060 F +1-949-336-1940
info@aquastarpoolproducts.com www.aquastarpoolproducts.com

FLOW STAR® SKIMMER WITH WATER STOP FACE, FLOAT ASSEMBLY, BASKET, LID AND ADJUSTABLE COLLAR

Built in conformance with NSF 50 and SPS 3 standards

FEATURES

- Adjustable collar
- New water stop face secures the clips in the water door
- Self-contained gasket, gasket water stop on the float to prevent water leaks
- Optional vacuum basket with lock-in feature (sold separately)
- Underwater drainage on the backface for rapid reduction on water table - especially on windy days
- Super strong engineered polymer upper housing
- Extra heavy duty PVC lower unit (not recommended for use)
- 2" outside dip and 2" inside dip (inside skimmer)
- 2" threads for pressure testing (inside skimmer)
- Bubbler overflow or fill line knock out
- Upper housing for pre-cut outer covers with pre-drilled holes for fit use
- Skimmer Lid and Collar G154 UV tested
- 100 GPM approved for commercial use, 20 GPM max, 55 GPM max - approved for residential use up to 100 GPM
- See page 112 for code compliance and sizing
- Optional custom name logo engraved on the lid (requires minimum 500 pieces & order)
- See page 137 for Skimmer with Quone Port
- 1 per case

Three lid options available (sold separately): round, square or snap-in round/square

Part # SKR1xx

For vinyl and fiberglass options, see pages 138-143

STANDARD COLORS

- SKR101 - White
- SKR102 - Black
- SKR103 - Light Gray
- SKR104 - Blue
- SKR105 - Dark Gray
- SKR108 - Tan

1. Skimmer Body
2. 2" Port Plug
3. Float Assembly
4. Basket
5. Weir Clip, Qty 2
6. Collar
7. Lid
8. Water Assembly

P 877-768-2717 F 877-276-POOL Outside the US: P +1-805-620-5060 F +1-949-336-1940
info@aquastarpoolproducts.com www.aquastarpoolproducts.com

TAG 5 - FLOW METER - FW-3-40 - 3 INCH INLINE COMMERCIAL FLOWMETER

TAG 6 - MAIN DRAIN - 9MF101 - 9 INCH SQUARE VGB SUCTION OUTLET

TAG 7 - HYDROSTATIC RELIEF - HVC101 - HYDROSTATIC RELIEF VALVE

TAG 8 - SKIMMER - SKR101 - WHITE COMMERCIAL GRADE SKIMMER

DATE	REVISION	NO.

SHEET DISCUSSION
Specifications
PROJECT #: 2022002
DATE ISSUED: 07/20/2022
DRAWING BY: JVD
CHECKED BY: DSC/JLH

**WOODGROVE
DR HORTON
BATHHOUSE & POOL
HARNETT COUNTY, NC**



STANDARD COLORS 01 02 03

39 ProStar # VLK15Txx
REPLACES # W4008WHP



Safety Vacuum Lock Wall Fitting (1 1/2" NPT)
Part # VLK20Txx (2" NPT)
Meets SPS-4-2009 Standard

40 ProStar # HWN153
REPLACES # AXV74P



Flow Gauge

41 ProStar # HWN158
REPLACES # AXV92



Hose Connector

42 ProStar # SZTHxx
REPLACES # V108



4-Foot Regular Hose

43 ProStar # SZTLHxx
REPLACES # V532



4-Foot Leader Hose

44 ProStar # HWN163xx
REPLACES # AXV14604



Wing Kit and Pod Shoes

AQUASTAR pool products
A Safe Drain Is No Accident™

2" X 4" GUTTER DECK DRAIN (FITS 2" PIPE)

FEATURES
Fits over 2" pipe
1 1/2" threaded FPT inside for pressurizing/waterlocking
Manufactured from engineered polymer UV-resistant PVC material (g/n GDD101 is manufactured from engineered polymer UV-resistant ABS material)
1 1/2" reducer bushing available p/n BU101-2x1.5
1/2" stackable extender available p/n PE20101
Stainless steel screws
Also available as grate only with two screws
CAUTION: Not to be used as a suction outlet under any circumstances
25 per case
Grate only p/n GDDLxx
25 per case



Part # GDxx

STANDARD COLORS
 101 104
 102 105
 101 108

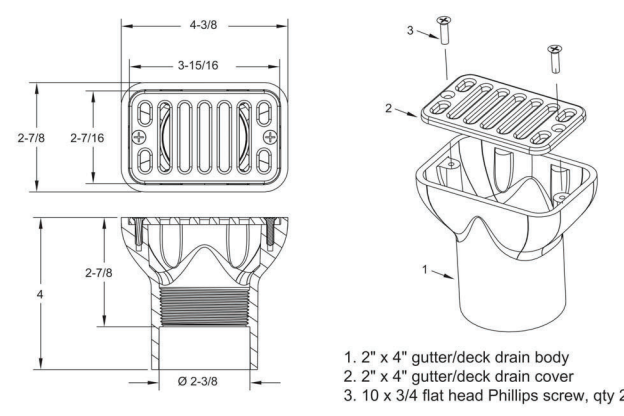

1. 2" x 4" gutterback drain body
2. 2" x 4" gutterback drain cover
3. 10 x 3/4 flat head Phillips screw, qty 2

P 877-768-2717 F 877-276-POOL Outside the US: P +1-805-620-5060 F +1-949-336-1940
info@aquastarpoolproducts.com www.aquastarpoolproducts.com

★ PROUDLY MADE ★ IN THE USA

Large Wall Fitting (Fits Inside 2" Pipe)

FEATURES
Fits inside 2" pipe, 1 1/2" FPT in the front face
Large flange camouflages pipe and surface construction variations
See also decorative cover p/n DCxx to make existing 1022-like new with different colors
Manufactured from engineered polymer UV-resistant ABS material
250 per case
Also available in Clear (p/n ES1022520xx)

NEW



Part # ES1022520xx



Three-Piece Directional Eyeball Fitting 1 1/2" MPT

FEATURES
Screws into 1 1/2" FPT
Manufactured from engineered polymer UV-resistant ABS material
250 per case

Eyeball orifice size part #: 1" - 81xx, 1 1/2" - 82xx, 1 3/4" - 83xx, slotted - 84xx (E.g. 801 - white 1" orifice)
Also available in clear (p/n 8100, 8200, 8300, 8400)



Part # 81xx, 82xx, 83xx, 84xx

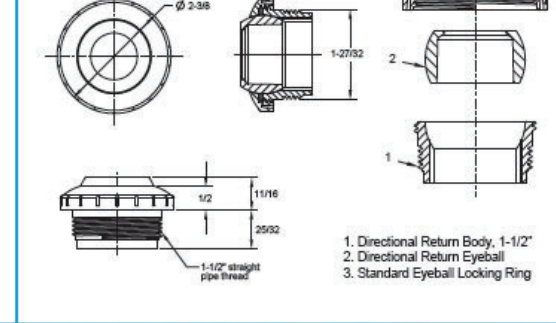

1. Directional Return Body, 1 1/2"
2. Directional Return Eyeball
3. Standard Eyeball Lock Ring

AQUASTAR pool products
Flush Retro-fit Eyeball

Product Image and Dimensions

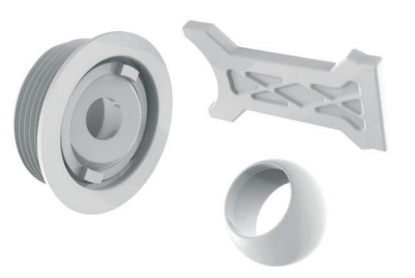

Part # JOxx

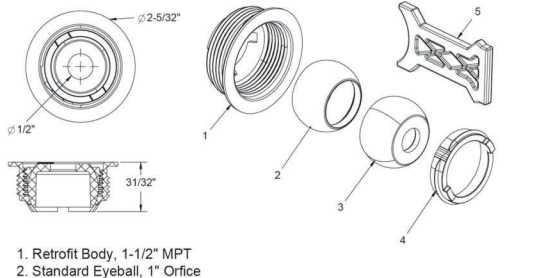

1. Return Body, 1 1/2" MPT
2. Standard Eyeball, 1" Orifice
3. Standard Eyeball, 1 1/2" Orifice
4. Return Lock Nut
5. Return Nut Wrench

FEATURES
- Threads into 1 1/2" FPT
- Includes wrench, retro-fit nut, retro-fit socket, 1/2" eyeball and 1" eyeball
- Fits flush inside flush mount fittings
- Changes color of existing fitting
- Makes existing old fitting look new
- Eliminates the need to chip out the old fitting
50 per case

STANDARD COLORS
 JO101 Comes with 1/2" and 1" eyeballs.
 JO102
 JO103 Additional orifice sizes available separately, comes with locking nut. See part numbers below:
 JO104 ENBxxx - 3/4"
 JO105 ENDxxx - Slotted Down-Jet
 JO108

AquaStar Specific Eyeball GPM, Velocity and Head Loss Ratings

GPM	ENxxx (1")		ENBxxx (3/4")		ENCxxx (1/2")		ENDxx (Down-Jet)	
	Velocity (fps)	Head Loss (ft)	Velocity (fps)	Head Loss (ft)	Velocity (fps)	Head Loss (ft)	Velocity (fps)	Head Loss (ft)
5	2.2	0.1	3.6	0.5	8.2	2.4	10.1	2.1
10	4.4	0.5	7.3	1.8	16.3	8.7	20.2	8.1
15	6.6	1.1	10.9	3.7	24.5	18.6	30.3	20.7
20	8.8	1.9	14.5	6.2	32.4	32.0		
25	11.0	3.0	18.2	9.4				
30	13.2	4.4	21.8	13.1				
35	15.4	6.1	25.4	17.3				
40	17.6	8.0						
45	19.7	10.2						
50	21.9	12.7						

P 877-768-2717 F 877-276-POOL Outside the US: P +1-805-620-5060 F +1-949-336-1940
info@aquastarpoolproducts.com www.aquastarpoolproducts.com

★ PROUDLY MADE ★ IN THE USA

TAG 9 - VACUUM INLET - VLK15T01 - VACUUM LINE LOCK CAP

TAG 10 - OVERFLOW DRAIN - GDD101 - COMMERCIAL OVERFLOW DRAIN

TAG 11 - RETURN INLET - 8101 - WALL RETURN INLET FITTING

TAG 12 - RETURN INLET - JO101 - FLUSH FLOOR RETURN INLET

AQUASTAR pool products
A Safe Drain Is No Accident™

FillStar™ Water Level Control System for Pools and Spas

Durable and reliable

FEATURES
Can be installed alone or with drain/vacuum pool or spa at all times
Easy to install
Overflow protection and adjustable presets
Uses the same size lid and collar as AquaStar skimmers
Includes a 2" to 1 1/2" adapter
3/4" plug included if overflow is not needed
3/4" water supply inlet
Valve is made of high-strength engineered resin
Float is injection-molded; thread is pre-molded
All fittings are made of PVC
No transition glue needed
Float thread is 1/2" MPT
1 per case



Part # AFBxxx

Also available float only part # AFBV

STANDARD COLORS
 AFB101 - White
 AFB102 - Black
 AFB103 - Light Gray
 AFB104 - Blue
 AFB105 - Dark Gray
 AFB108 - Tan



Also available without lid and collar p/n AFBNLxxx
Also available cover only p/n SKR10xx

P 877-768-2717 F 877-276-POOL Outside the US: P +1-805-620-5060 F +1-949-336-1940
info@aquastarpoolproducts.com www.aquastarpoolproducts.com

★ PROUDLY MADE ★ IN THE USA

8/14/2019
GloBrite White LED Lights | Pool Lighting | Pentair

Item #: 602103
Description: GloBrite White LED Light
Voltage: 12V
Wattage: 15W
Cord Length (Ft.): 50
Carton Qty.: 1
Carton Wt. (Lbs.): 6

Item #: 602104
Description: GloBrite White LED Light
Voltage: 12V
Wattage: 15W
Cord Length (Ft.): 100
Carton Qty.: 1
Carton Wt. (Lbs.): 9

Item #: 602105
Description: GloBrite White LED Light
Voltage: 12V
Wattage: 15W
Cord Length (Ft.): 150
Carton Qty.: 1
Carton Wt. (Lbs.): 12

Item #: 620040
Description: Gunite Niche for GloBrite (includes white, blue, grey and tan rings)
Voltage:
Wattage:
Cord Length (Ft.):
Carton Qty.: 1
Carton Wt. (Lbs.): 1.3

Item #: 620039
Description: Vinyl Niche for GloBrite (includes white, blue, and grey rings)
Voltage:
Wattage:
Cord Length (Ft.):
Carton Qty.: 1
Carton Wt. (Lbs.): 1.3

Feedback

https://www.pentair.com/en/products/pool-spa-equipment/pool-lighting/globrite_white_poolandspalights.html

4/6

INTELLIBRITE® 5G WHITE LED
UNDERWATER LED LIGHTS FOR SWIMMING POOLS AND SPAS

Featured Highlights

- The brightest most energy efficient white LED pool light on the market
- Energy efficient utilizing up to 86% less energy than comparable incandescent lights
- Superior lens geometry and innovative reflector design combine to create a wider beam and more uniform light distribution
- Pool lens can be rotated to 180 degrees to provide wide beam pattern (standard) or narrow beam pattern
- Compatible with Pentair Stainless steel and plastic niches
- Available in 120V and 12V versions
- Available in 300W, 400W, and 500W incandescent equivalencies

Ordering Information for Pool Lights

Product	Voltage	Cord Length (Ft.)	Incandescent Equivalency	Carton Qty.	Carton Wt. (Lbs.)
INTELLIBRITE 5g WHITE POOL LIGHTS - 500 WATT EQUIVALENT, 120 VOLT					
601100	120V	30 ft.	300W Equivalency	1	
601101	120V	50 ft.	300W Equivalency	1	
601102	120V	100 ft.	300W Equivalency	1	
601103	120V	150 ft.	300W Equivalency	1	
601104	120V	250 ft.	300W Equivalency	1	
INTELLIBRITE 5g WHITE POOL LIGHTS - 300 WATT EQUIVALENT, 120 VOLT					
601105	12V	30 ft.	300W Equivalency	1	
601106	12V	50 ft.	300W Equivalency	1	
601107	12V	100 ft.	300W Equivalency	1	
601108	12V	150 ft.	300W Equivalency	1	
INTELLIBRITE 5g WHITE POOL LIGHTS - 400 WATT EQUIVALENT, 120 VOLT					
601200	120V	30 ft.	400W Equivalency	1	
601201	120V	50 ft.	400W Equivalency	1	
601202	120V	100 ft.	400W Equivalency	1	
601203	120V	150 ft.	400W Equivalency	1	
601204	120V	250 ft.	400W Equivalency	1	
INTELLIBRITE 5g WHITE POOL LIGHTS - 400 WATT EQUIVALENT, 12 VOLT					
601205	12V	30 ft.	400W Equivalency	1	
601206	12V	50 ft.	400W Equivalency	1	
601207	12V	100 ft.	400W Equivalency	1	
601208	12V	150 ft.	400W Equivalency	1	
INTELLIBRITE 5g WHITE POOL LIGHTS - 500 WATT EQUIVALENT, 120 VOLT					
601300	120V	30 ft.	500W Equivalency	1	
601301	120V	50 ft.	500W Equivalency	1	
601302	120V	100 ft.	500W Equivalency	1	
601303	120V	150 ft.	500W Equivalency	1	
601304	120V	250 ft.	500W Equivalency	1	
INTELLIBRITE 5g WHITE POOL LIGHTS - 500 WATT EQUIVALENT, 12 VOLT					
601305	12V	30 ft.	500W Equivalency	1	
601306	12V	50 ft.	500W Equivalency	1	
601307	12V	100 ft.	500W Equivalency	1	
601308	12V	150 ft.	500W Equivalency	1	

Please refer to page 117 for CSA listed IntelliBrite Pool Lights.

UL LISTED

LIGHTING - WHITE

INTERMATIC®

COMBOConnect® Junction Box Transformer
Model PJBX52100



SIMPLIFY POOL, SPA AND LANDSCAPE LIGHTING INSTALLATIONS
COMBOConnect combines the simplicity of a standard junction box with the power of a 100 W low-voltage transformer. Save time and money on installation of low-voltage nichelless pool lights and landscape lighting.

FEATURES & BENEFITS:

- Compact Size** - Great for space-constrained areas, COMBOConnect uses at least 20 percent less space than traditional components, preserving wall space and fittings. It's also compatible with direct gluing of non-metallic flexible conduit.
- Voltage Options** - 12 or 13 volt tap option gives installers the ability to compensate for voltage drop.
- Expandable** - Two high-voltage ports allows "daisy-chaining" between two COMBOConnect units for larger lighting projects. Low-voltage ports accept 16/2 and 18/2 AWG cord sizes, accommodating all major pool safety light manufacturers.
- Noise Reduction** - Built-in electronic noise reduction technology helps the electrical performance of the LED lights.
- Easy Access** - COMBOConnect provides quick access to all connection points and openings. Terminal bars allow for quick, clean and secure connections, as well as easy troubleshooting and testing.

APPLICATIONS:

- In-Ground Pools and Spas
 - Nichelless Low-Voltage Lights
- Landscape Lighting
- Fountain Lighting

COMBOConnect is listed and labeled per NEC 680.24 for use with pool and spa underwater luminaires and per NEC 411.1 for low-voltage landscape lighting.

Intermatic.com

Intermatic Incorporated 7777 Winn Road, Spring Grove, IL 60081 • (815) 675 7000
©2019 Intermatic - 200P510200

PA119

TAG 13 - AUTOFILL - AFB101 - FILLSTAR AUTOFILL

TAG 14 - LIGHT - 602104 - 190W GLOBRITE WHITE LED LIGHT

TAG 15 - LIGHT - 601107 - 300W INTELLIBRITE WHITE LED LIGHT

TAG 16 - JUNCTION BOX - PJBX52100 - JUNCTION BOX WITH TRANSFORMER

D. CLUGSTON



Kilian Engineering, Inc.
PO Box 4301, Healdston, NC 27536 | www.kilianengineering.com
(919) 454-4588/8178 | CORPORATE LICENSE C-2277

7-15-22

DATE: _____

REVISION: _____

NO.: _____

SHEET DISCUSSION
Specifications

PROJECT #: 2022002
DATE ISSUED: 07/20/2022
DRAWING BY: JVD
CHECKED BY: DSC/JLH

**WOODGROVE
DR HORTON
BATHHOUSE & POOL
HARNETT COUNTY, NC**

SP7