

VICINITY MAP

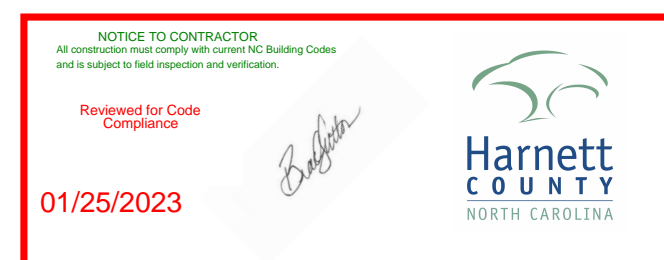

See attachments for windmill engineering. Foundation engineering included in this plan



FUQUAY-VARINA NORTH CAROLINA WINDMILL

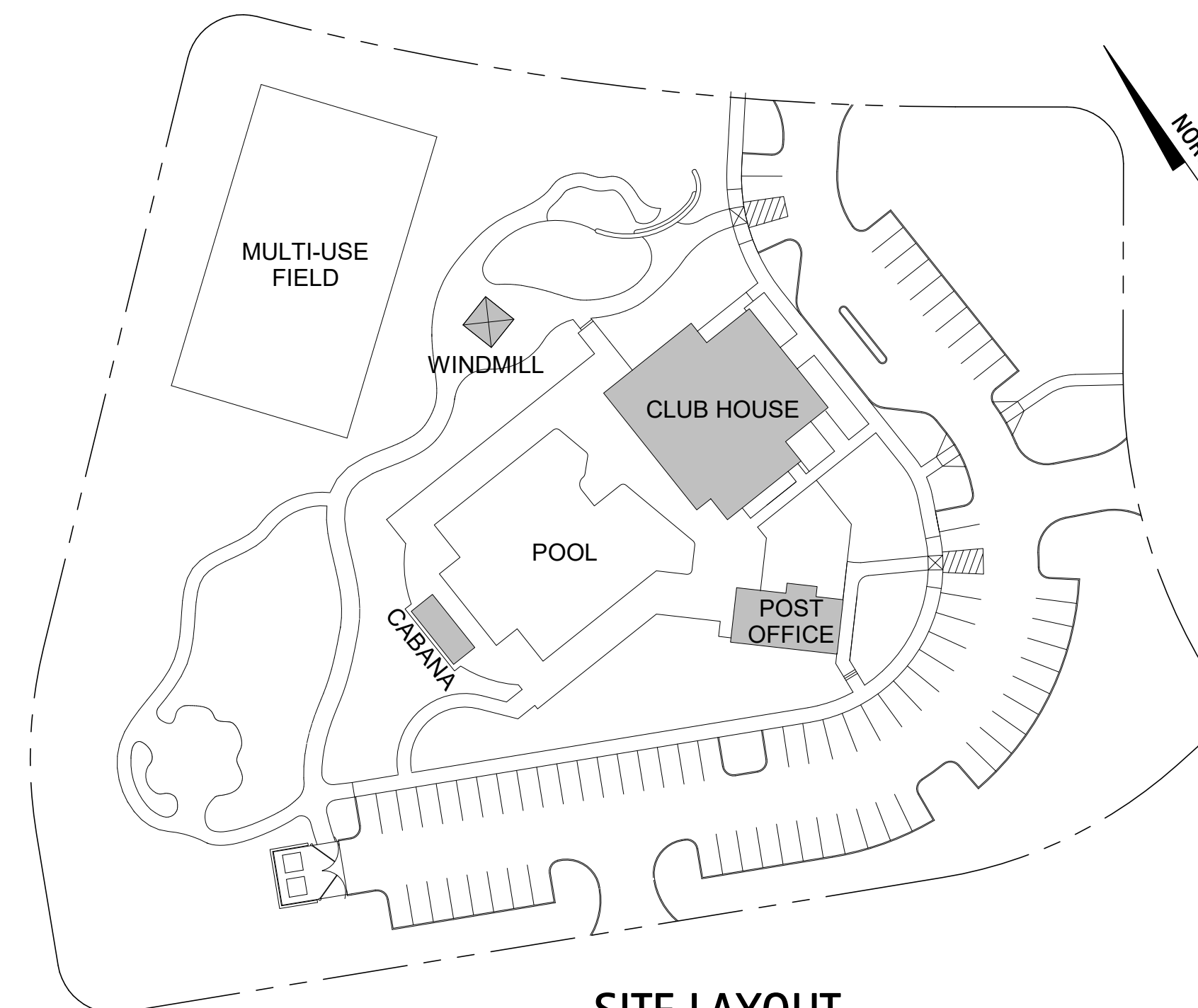

SITE LAYOUT
1" = 60'-0"



APPENDIX B BUILDING CODE SUMMARY

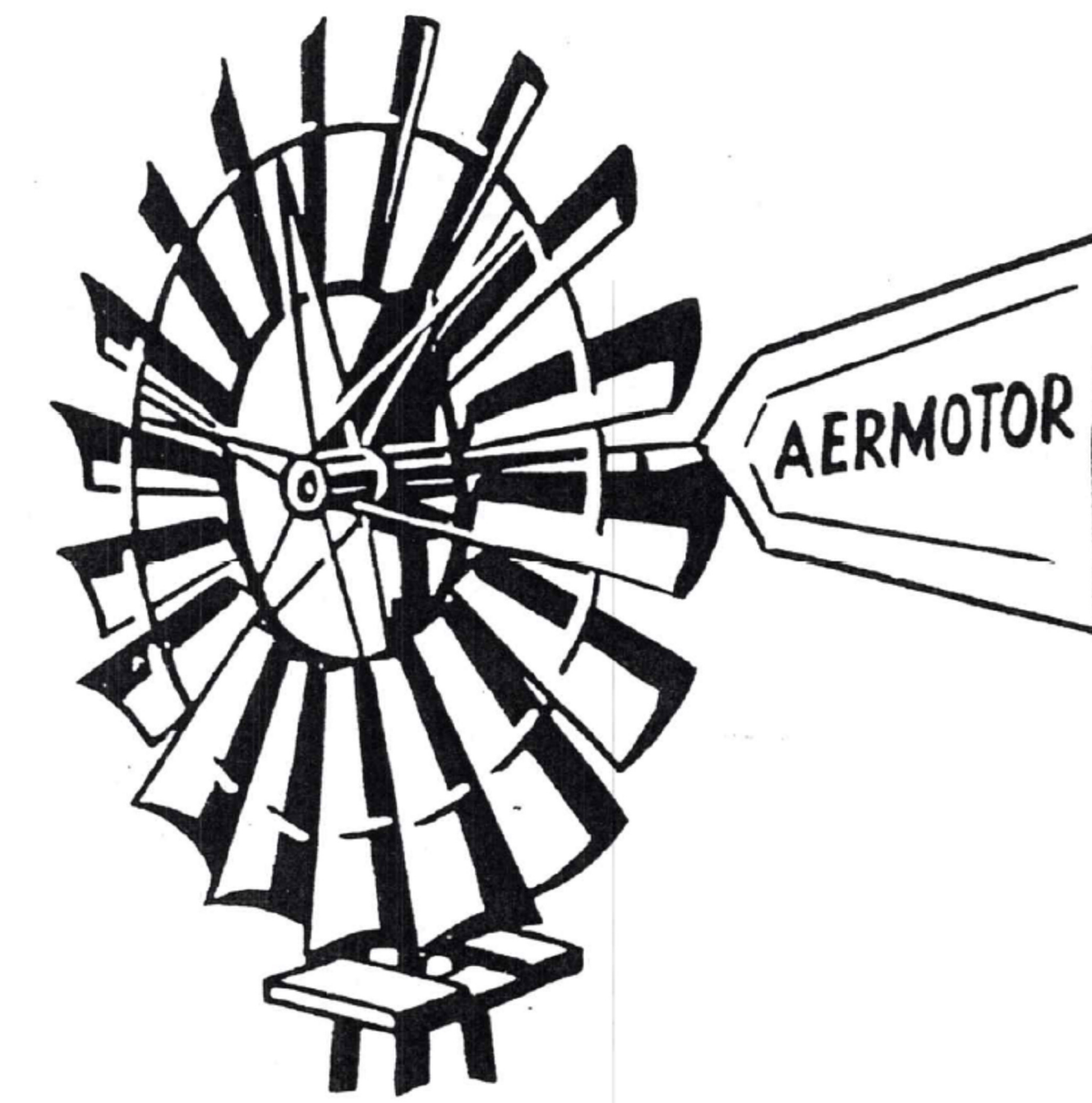

NO.	REVISION	DATE

SHEET DESCRIPTION	
WINDMILL SHEET	
PROJECT #:	2018.037
DATE ISSUED:	10/14/2022
DRAWING BY:	BSJ
CHECKED BY:	BSJ

SERENITY AMENITY
 GREENFIELD COMMUNITIES
 WINDMILL
 Fuquay-Varina, NC

Name of Project: Serenity Amenity
Address: 469 Piney Grove Rawls Rd., FV, NC Harnett County Zip Code: 27526
Owner or Authorized Agent: Brian Jacobs Phone #: 919.412.4711
Email: brian@clugston.com Fax #: N/A
Owned By: Privately City/County State
Code Enforcement Jurisdiction: City County City/County
Name of Jurisdiction: Town of Fuquay-Varina

PROJECT SUMMARY: PREMANUFACTURED - 40' WINDMILL TOWER AND 10' MILL
Building Description: TYPE 2B - (U) PRE MANUFACTURED UTILITY STRUCTURE
Scope of Work: Windmill and Structural Drawings.

Lead Design Professional/Project Coordinator: Brian Jacobs 919-412-4711
DESIGNER: FIRM NAME LICENSE # TELEPHONE #
Architectural: _____
Civil: _____
Electrical: _____
Fire Alarm: _____
Plumbing: _____
Mechanical: _____
Sprinkler-Standpipe: _____
Structural: Ross Linden Engineers Brian Ross, PE 25539 919-832-5680
Precast: _____
Trusses: _____
Retaining Walls >5' High: _____
Other: _____
Note: _____

FOR ALL COMMERCIAL PROJECTS

BUILDING DATA
 THIS SECTION REQUIRED FOR ALL PROJECTS

Construction Type: I-A I-B II-A II-B III-A III-B IV-HT V-A V-B

Mixed construction: Yes No Types _____
 Sprinklers: Yes No NFPA 13 NFPA 13R Partially Sprinklered Special Suppression

Standpipes: Yes No Class: I II III Wet Dry
 Fire District: Yes No (Appendix D) Floor Hazard
 Building Height: 45 Feet 1 Story
 Basement: Yes No
 Mezzanine: Yes No
 High Rise: Yes No
 Life Safety Plan Sheet # (if provided): n/a

FLOOR	EXISTING (SQFT)	NEW (SQFT)	SUB-TOTAL

Area of Project Tenant/Alteration/Renovation: _____
 Area of Construction: _____

Building Code: 2018 North Carolina State Building Code (NCSBC) 2009 North Carolina State Building Code
 2009 NC Rehab 2006 NC Rehab 2006 North Carolina Building Code
 2009 Chapter 34 2006 Chapter 34 1995 Existing Building Code

New Building: New Building Shell Building First Time Interior Completion
 Addition Alteration to Shell

Existing Building: Renovation Interior Completion Tenant Alteration
 Reconstruction Repair Alteration to Shell
 Change of Use Change of Occupancy

Note: Zoning Review May Be Required for Change of Use or Occupancy
 Original Occupancy: _____
 Proposed Occupancy: Utility

OCCUPANCY INFORMATION

Primary Occupancies:
 Assembly: A-1 A-2 A-3 A-4 A-5
 Hazardous: H-1 H-2 H-3 H-4 H-5
 Institutional: I-1 Condition 1 2
 I-2 Condition 1 2
 I-3 Condition 1 2 3 4 5
 I-4
 Mercantile:
 Residential: R-1 R-2 R-3 R-4
 Storage: S-1 Moderate S-2 Low High-piled
 Parking Garage: Open Enclosed Repair Garage

Utility and Miscellaneous

Special Occupancies: 402 403 404 405 406 407 408 409 410 411
 412 413 414 415 416 417 418 419 420 421

Mixed Occupancy: No Yes Separation: _____ Hr. Exception: _____

Non-Separated Mixed Occupancy (508.3) - The required type of construction for the building shall be determined by applying the height and area limitations for each of the applicable occupancies to the entire building. The most restrictive type of construction, so determined, shall apply to the entire building.

Separated Mixed Occupancy (508.3.3) - See below for area calculations for each story, the area of the occupancy shall be such that the sum of the ratios of the actual floor area of each use divided by the allowable floor area for each use shall not exceed 1.

$\frac{\text{Actual Area of Occupancy A}}{\text{Allowable Area of Occupancy A}} + \frac{\text{Actual Area of Occupancy B}}{\text{Allowable Area of Occupancy B}} \leq 1$

STRUCTURAL DESIGN LOADS

THIS SECTION IS REQUIRED FOR ALL PROJECTS

DESIGN LOADS:
 Importance Factors: Snow (I_s) _____
 Seismic (I_s) _____
 Live Loads: Roof _____ psf
 Mezzanine _____ psf
 Floor _____ psf
 Ground Snow Load: Ultimate Wind Speed _____ mph (ASCE-7)
 Wind Load: Exposure Category _____

SEISMIC DESIGN CATEGORY: A B C D
 Provide the following Seismic Design Parameters:
 Risk Category (Table 1604.5) _____
 Spectral Response _____
 Site Classification _____

Basic Structural System: Field Test Presumptive Historical Data
 Bearing Wall Dual w/ Special Moment Frame
 Building Frame Dual w/ Intermediate R/C or Special Steel
 Moment Frame Inverted Pendulum
 Simplified Equivalent Lateral Force Dynamic

Analysis Procedure: Architectural, Mechanical, Components anchored? Yes No

LATERAL DESIGN CONTROL: Earthquake _____ Wind _____

SOIL BEARING CAPACITIES:
 Field Test (provide copy of test report) _____ psf
 Presumptive Bearing Capacity _____ psf
 File size, type, and capacity _____

ALLOWABLE HEIGHT

MOST RESTRICTIVE (GROUP)	ALLOWABLE BUILDING HEIGHT (TABLE 504.3)	INCREASE FOR SPRINKLERS	ACTUAL BUILDING HEIGHT AS SHOWN ON PLANS	CODE REFERENCE
Type of Construction	Type 1A	Type N/A	Type 2B	403.3.1
Building Height in Feet	H = 75 FT	N/A	H = 45 FT	403.3.1
Building Height in Stories	S = 1	N/A	S = 1	403.3.1

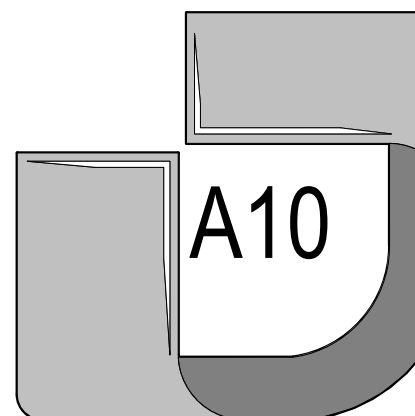

STRUCTURAL NOTES

I. GENERAL

1. DESIGN CODES

NORTH CAROLINA BUILDING CODE, 2018 EDITION
(AMENDED 2015 INTERNATIONAL BUILDING CODE)
ACI BUILDING CODE REQUIREMENTS FOR STRUCTURAL CONCRETE
(ACI 318-14)
ASCE 7-10 MINIMUM DESIGN LOADS FOR BUILDINGS AND OTHER
STRUCTURES

2. DESIGN LOADS

ULTIMATE DESIGN WIND SPEED: 115 MPH (EXPOSURE C)
GROUND SNOW LOAD 15 PSF
SEISMIC DESIGN CATEGORY B
SITE CLASS D
Ss = 0.170
S1 = 0.082

3. DETAILED SHOP DRAWINGS SHALL BE PROVIDED FOR REVIEW AND APPROVAL
PRIOR TO CONSTRUCTION.

4. DIMENSIONS HAVE BEEN PROVIDED BY AMERICAN WINDMILLS BASED ON A 40 FT
TOWER AND 10 FT DIAMETER MILL. ANCHOR POSTS SHALL BE EMBEDDED IN THE
CONCRETE FOUNDATION PER THE RECOMMENDATIONS OF THE MANUFACTURER. IT IS THE RESPONSIBILITY OF THE CONTRACTOR TO VERIFY ALL DIMENSIONS
PRIOR TO CONSTRUCTION.

5. ENGINEER'S SEAL APPLIES TO FOUNDATION COMPONENTS ONLY AND DOES
NOT CERTIFY ARCHITECTURAL LAYOUT OR DIMENSIONAL ACCURACY. ALL
COMPONENTS OF THE WINDMILL ARE PROVIDED BY THE MANUFACTURER. THE
FOUNDATION HAS BEEN DESIGNED TO SUPPORT THE WINDMILL COMPONENTS
PROVIDED BY OTHERS.

6. ROSS LINDEN ENGINEERS PC ASSUMES NO LIABILITY FOR CHANGES OR
MODIFICATIONS MADE TO THESE DRAWINGS BY OTHERS, OR FOR CONSTRUCTION
METHODS, OR FOR ANY DEVIATION FROM THESE DRAWINGS.

II. CONCRETE

1. UNLESS OTHERWISE NOTED, ALL CONCRETE SHALL HAVE THE FOLLOWING
STRENGTH AND SLUMP REQUIREMENTS:
3,500 PSI 28-DAY COMPRESSIVE STRENGTH, MAX. 5" SLUMP.

2. ALL CONCRETE SHALL BE MOIST CURED PER ACI 301 OR CURED WITH AN
APPROVED CURING COMPOUND. CONCRETE SHALL BE CURED FOR A MINIMUM
OF 7 DAYS.

3. UNLESS OTHERWISE NOTED, ALL REINFORCING STEEL SHALL BE NEW BILLET
STEEL, CONFORMING TO ASTM A-615, GRADE 60, DEFORMED.

4. UNLESS OTHERWISE NOTED, ALL DETAILING, FABRICATION, AND PLACING OF
REINFORCING STEEL SHALL CONFORM TO THE MANUAL OF STANDARD PRACTICE
FOR DETAILING REINFORCED CONCRETE STRUCTURES. (ACI 315)

5. ALL BAR SPLICES SHALL BE CLASS "B" TENSION SPLICES PER ACI 318-14,
UNLESS OTHERWISE SHOWN.

6. CONTRACTOR SHALL REFER TO DRAWINGS OF OTHER TRADES AND VENDOR
DRAWINGS FOR EMBEDDED ITEMS AND RECESSES NOT SHOWN ON THE
STRUCTURAL DRAWINGS.

7. ALL SPREAD FOOTINGS BEARING ON NATIVE SOIL OR STRUCTURAL FILL ARE
DESIGNED FOR AN ALLOWABLE BEARING PRESSURE OF 2,500 PSF. A
GEOTECHNICAL REPRESENTATIVE SHALL INSPECT ALL FOOTING EXCAVATIONS
TO CONFIRM ALLOWABLE BEARING PRESSURES.

8. CONTRACTOR SHALL BE RESPONSIBLE FOR LOCATING, PROTECTING, AND
RELOCATING AS REQUIRED ALL SERVICE AND UTILITY LINES IN VICINITY OF THE
WORK SITE.

9. ALL DOWELS WHICH ARE TO BE DRILLED AND GROUTED INTO EXISTING
CONCRETE SHALL BE DONE WITH AN EPOXY GROUT. DRILL HOLE WITH
DIAMETER 1/8" LARGER THAN DOWEL OR AS RECOMMENDED BY GROUT
SUPPLIER. USE HIT-RE 500 V3 BY HILTI OR APPROVED EQUAL.

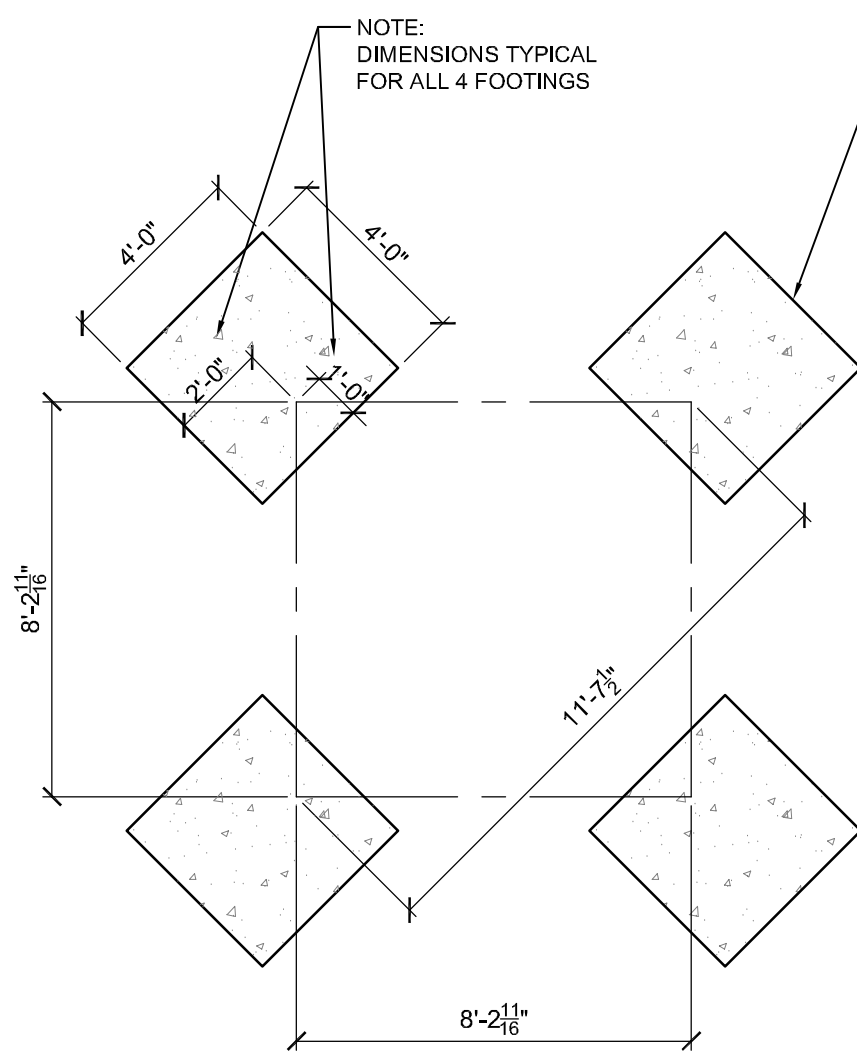

4'-0" x 4'-0" x 5'-0" DEEP FOOTINGS
(TYPICAL 4 LOCATIONS).
EMBED TOWER LEG IN FOOTING
PER MANUFACTURER'S
RECOMMENDATIONS.

NOTE:
DIMENSIONS HAVE BEEN PROVIDED
BY AMERICAN WINDMILLS BASED ON
A 40 FT TOWER AND 10 FT DIAMETER
MILL. IT IS THE RESPONSIBILITY OF
THE CONTRACTOR TO VERIFY ALL
DIMENSIONS PRIOR TO
CONSTRUCTION.

1 WINDMILL FOUNDATION PLAN
S1 1/4" = 1'-0"

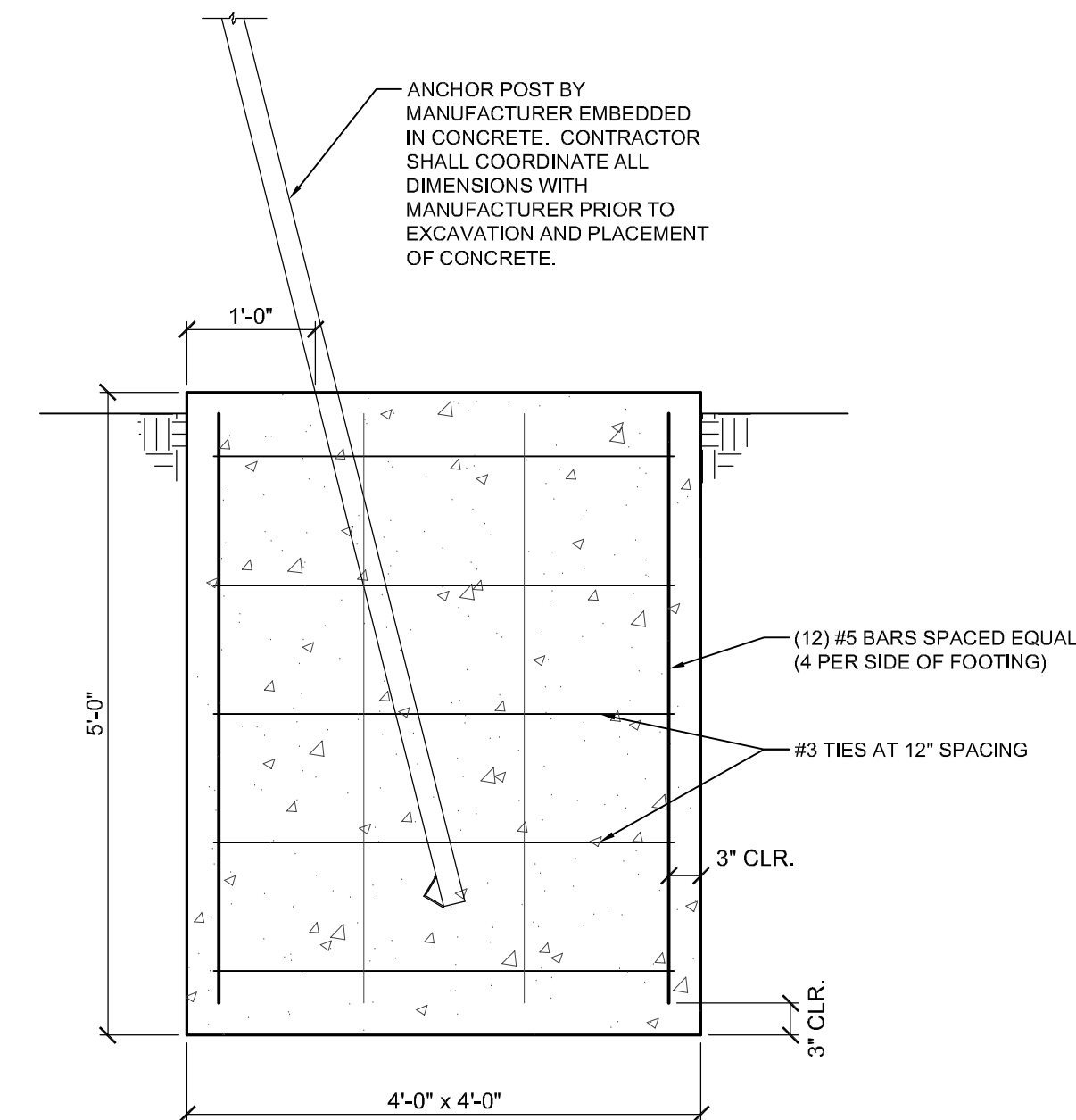

ANCHOR POST BY
MANUFACTURER EMBEDDED
IN CONCRETE. CONTRACTOR
SHALL COORDINATE ALL
DIMENSIONS WITH
MANUFACTURER PRIOR TO
EXCAVATION AND PLACEMENT
OF CONCRETE.

(12) #5 BARS SPACED EQUALLY
(4 PER SIDE OF FOOTING)

#3 TIES AT 12" SPACING

3" CLR.

3" CLR.

2 SECTION - TYP. FOOTING
S1 3/4" = 1'-0" TYPICAL AT EACH OF (4) WINDMILL LEGS



ROSS LINDEN
ENGINEERS PC
709 W. BONES STREET RALEIGH, NC 27603
TEL 919.832.5680 FAX 919.832.5675
WWW.ROSSLINDEN.COM NC LICENSE NO. C-2384

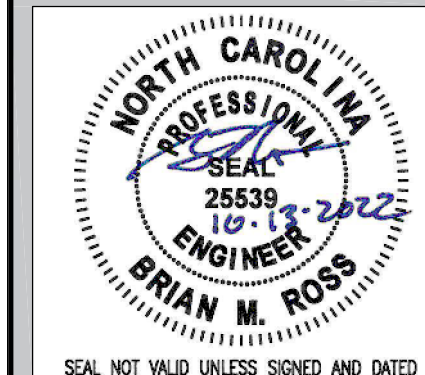

Copyright Ross Linden Engineers PC
2022. All rights reserved. No part of
these pages, either text or image may be
used for any other purpose. Therefore,
reproduction, modification, storage in
retrieval system or retransmission, in any
form or by any means, electronic,
mechanical, or otherwise, for reasons
other than intended use on the specific
project, is strictly prohibited without prior
written permission.

NO.	REVISION	DATE

SHEET DESCRIPTION WINDMILL FOUNDATION PLAN AND DETAILS	
PROJECT #:	C220809
DATE ISSUED:	10/13/2022
DRAWING BY:	BMR
CHECKED BY:	BMR/BSJ

SERENITY AMENITY
GREENFIELD COMMUNITIES
Fuquay-Varina, NC

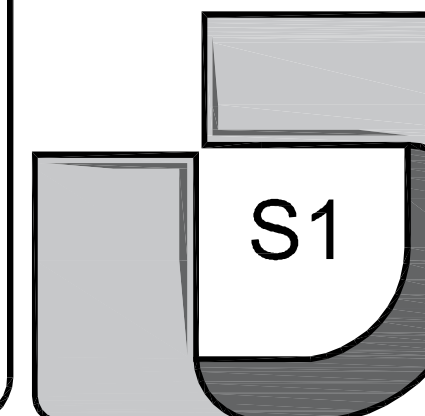

PROJECT: SERENITY AMENITY
 LOCATION: PINEY GROVE RAWLS ROAD
 OWNER: GREENFIELD COMMUNITIES LLC
 8601 SIX FORKS ROAD, SUITE 270
 RALEIGH, NC 27615
 PHONE: 919-815-6469
 MATT BRUBAKER
 MBRUBAKER@GREENFIELDCOMMUNITES.COM

LANDSCAPE ARCHITECT: TMTLA ASSOCIATES
 5011 SOUTHPARK DRIVE, STE 200
 DURHAM, NC 27713
 PHONE: 919-484-8880
 GARRETT BAKER, PLA
 GARRETT@TMTLA.COM

BUILDING ARCHITECT: D. CLUGSTON, INC.
 2506 RELIANCE AVE
 APEX, NC 27539
 PHONE: 919-629-7290
 BRIAN JACOBS
 BRIAN.JACOBS@DCLUGSTON.COM

ENGINEER: TIMMONS GROUP
 5410 TRINITY ROAD, SUITE 102
 RALEIGH, NC 27607
 PHONE: 919-866-4951
 JIM CHANDLER, PE
 JIM.CHANDLER@TIMMONS.COM

SITE DATA

PIN: TO BE DETERMINED
 DEVELOPMENT TYPE: PUD, APPROVED JULY 9, 2018
 TOWNSHIP: HECTORS CREEK
 PROPOSED USE: RESIDENTIAL AMENITY (COMMERCIAL)
 LAND USE CLASSIFICATION: MEDIUM DENSITY RESIDENTIAL
 TOTAL SITE AREA: 4.03 AC
 ZONING: RA-40
 BUILDING SETBACK: 50'
 PARKING SETBACK: 10'
 PARKING: 1 PER 200 SF
 STREET TREE: PER DEVELOPMENT PLAN
 PROPOSED IMPERVIOUS:
 CLUBHOUSE AND POST OFFICE 6018 SF
 POOL DECK 8759 SF
 SIDEWALKS AND MISC 5736 SF
 VEHICULAR SURFACE AREA 31915 SF
 TOTAL 52,488 SF (1.2 AC)

SITE PLAN

SERENITY AMENITY

Piney Grove Rawls Road, Harnett County, North Carolina
 0-00-00-00
 MARCH 3rd, 2020

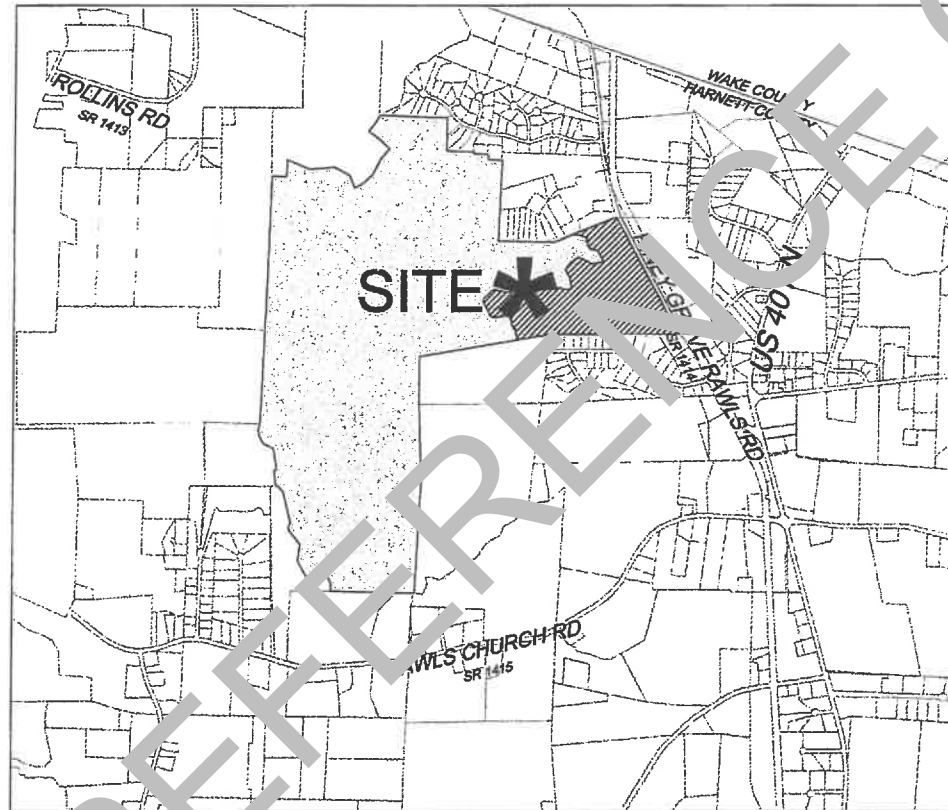

VICINITY MAP

SHEET INDEX:

- C-0.0 COVER
- C-1.0 EXISTING CONDITION, DEMOLITION AND EROSION CONTROL PLAN
- C-2.0 SITE PLAN
- C-2.1 PARKS ENLARGEMENT
- C-3.0 GRADING, DIMENSIONS AND UTILITY PLAN
- L-1.0 LANDSCAPE PLAN
- D-1.0 DETAILS
- D-1.1 DETAILS
- LO-1.0 LIGHTING PLAN - PRELIMINARY

AS THE OWNER OF RECORD, I HEREBY FORMALLY CONSENT TO THE PROPOSED DEVELOPMENT SHOWN ON THIS SITE PLAN AND ALL REGULATIONS AND REQUIREMENTS OF THE HARNETT COUNTY ORDINANCES.

Matthew Brubaker 2/25/20
 OWNER SIGNATURE DATE
 Matthew Brubaker, Manager
 PRINTED NAME, TITLE

I hereby certify that the Harnett County Development Review Board approves or approves with conditions this Site Plan and authorizes the design and construction of utilities and structures in accordance with all federal, state, and local government regulations and expiration periods that apply.

[Signature] 3/3/20
 Development Review Board, Chairman Date
 SITE 2003 - 0001



Know what's below.
 Call before you dig.

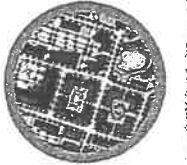

TMTLA ASSOCIATES
 5011 SOUTHPARK DRIVE, STE. 200 - DURHAM, NC 27713
 P: (919) 484-8880 - E: info@tmtla.com

D. CLUGSTON
 BUILDING AND DEVELOPMENT CO.

Timmons Group

REVISIONS:

10-14-20 comments revision

COVER
 SERENITY AMENITY
 Piney Grove Rawls Rd, Harnett County, NC
 GREENFIELD COMMUNITIES

SCALE:

DRAWN BY:
 JGB
 PROJECT #
 18081
 DATE:
 03/03/20
 SHEET

OF COVER

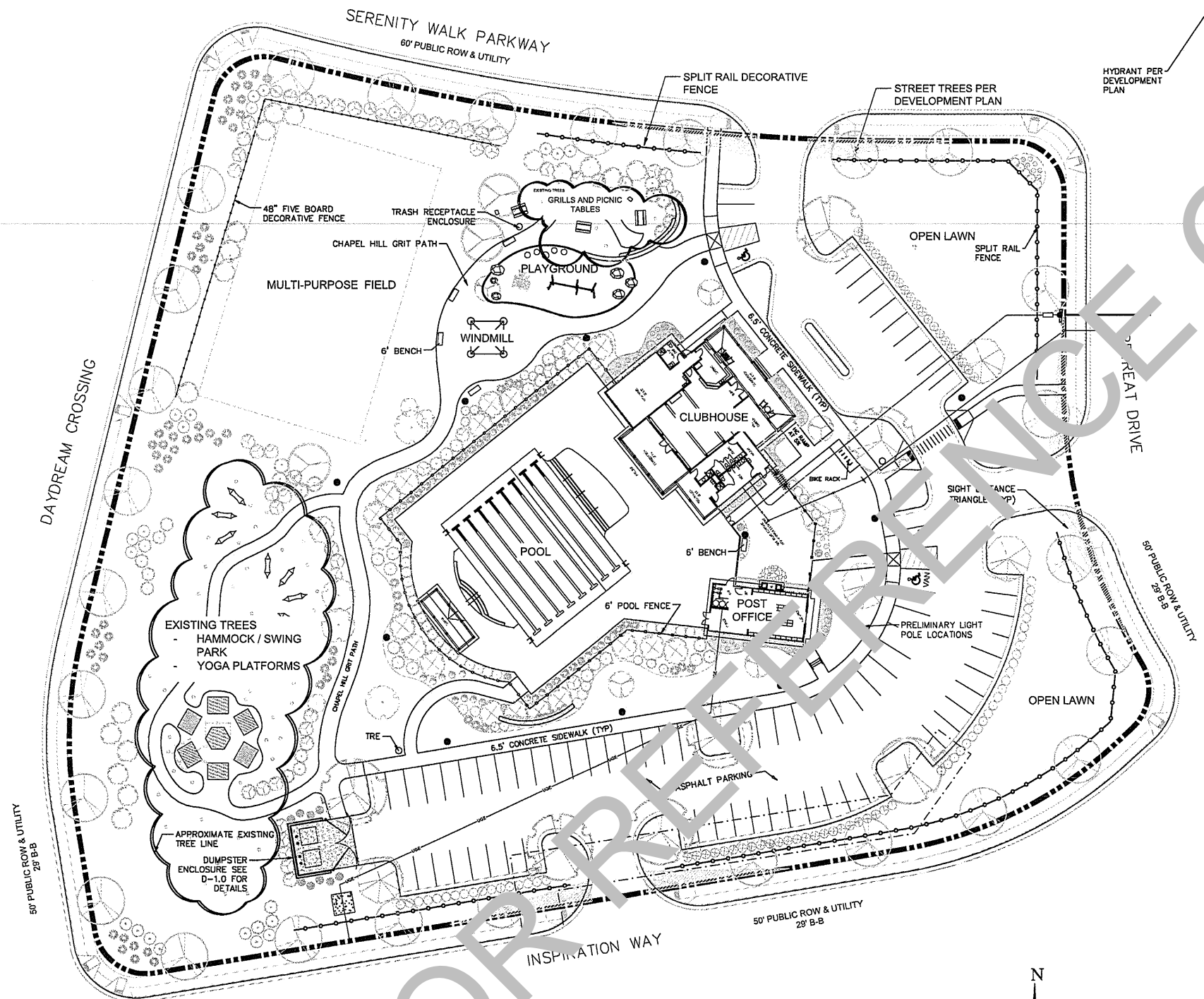

SITE DATA

TOTAL SITE AREA:	4.03 AC
PIN:	TO BE DETERMINED
PROPOSED USE:	RESIDENTIAL AMENITY (COMMERCIAL)
LAND USE CLASSIFICATION:	MEDIUM DENSITY RESIDENTIAL
CLUBHOUSE:	4775 SF
POST OFFICE:	107 SF
BUILDING SETBACK:	50'
PARKING SETBACK:	10'
PARKING:	1 PER 200 SF 5882/200= 29.4 SPACES REQUIRED 75 SPACES PROVIDED
STREET TREE:	PROVIDED PER DEVELOPMENT PLAN
PERIMETER BUFFER:	PARKING LOT SCREENING PROVIDED
DISTURBANCE AREA:	140,000 SF (3.21 AC)
PROPOSED IMPERVIOUS:	CLUBHOUSE AND POST OFFICE 6018 SF POOL DECK 8759 SF SIDEWALKS AND MISC 5736 SF VEHICULAR SURFACE AREA 31915 SF TOTAL 52,488 SF (1.2 AC)

- SITE PLAN NOTES:**
- CALL BEFORE YOU DIG. CALL THE NC ONE-CALL CENTER AT 1-800-632-4949. IT'S THE LAW.
 - EXISTING UTILITIES ARE SHOWN FROM THE BEST AVAILABLE INFORMATION AND ARE APPROXIMATE. IT IS THE CONTRACTOR'S RESPONSIBILITY TO VERIFY THESE AND OTHER UTILITIES BEFORE STARTING CONSTRUCTION. NOTIFY UTILITY LOCATING COMPANY (ONE CALL) 1-800-632-4949 OR INDIVIDUAL UTILITY OWNERS FOR UNDERGROUND LOCATIONS AT LEAST 48 HOURS IN ADVANCE.
 - CONTRACTOR SHALL CONTACT ALL OWNERS OF EASEMENTS, RIGHT-OF-WAYS AND UTILITIES, PUBLIC OR PRIVATE, BEFORE WORKING IN THESE AREAS.
 - CONTRACTOR SHALL PUT INTO PLACE SUCH TEMPORARY EROSION CONTROL MEASURES AS INDICATED ON THE PLANS AND AS PER THE SERENITY DEVELOPMENT PLAN. THESE MEASURES SHALL BE INSPECTED AND EVALUATED DURING CONSTRUCTION OPERATION FOR THEIR EFFECTIVENESS IN PREVENTING EROSION MATERIAL AND SEDIMENT FROM DISCHARGING FROM THE WORK AREA. AS DIRECTED BY THE TOWN/COUNTY INSPECTOR, ADDITIONAL TEMPORARY EROSION CONTROL MEASURES MAY BE REQUIRED.
 - UNLESS EXPLICITLY SPECIFIED IN THESE PLANS, ALL CONSTRUCTION SHALL BE COMPLETED IN ACCORDANCE WITH THE LATEST EDITION OF HARNETT COUNTY UNIFIED DEVELOPMENT ORDINANCE, STANDARD DETAILS AND SPECIFICATION, AND ALL OTHER APPLICABLE REGULATIONS AND GUIDELINES. IN THE EVENT OF A DISCREPANCY BETWEEN THIS APPROVED PLAN AND THE APPLICABLE REGULATIONS OR GUIDELINES, THE MORE STRINGENT SHALL APPLY.
 - CONTRACTOR SHALL MAINTAIN THE SITE IN A MANNER SUCH THAT WORKMEN AND THE PUBLIC WILL BE PROTECTED FROM INJURY, AND THE ADJOINING PROPERTY PROTECTED FROM DAMAGE.
 - CONTRACTOR SHALL REMOVE ALL TRASH AND DEBRIS FROM THE SITE UPON COMPLETION OF THE PROJECT AT LEAST ONCE A WEEK DURING CONSTRUCTION. DEBRIS SHALL BE DISPOSED OF IN A PROPER AND LEGAL MANNER. CONTRACTOR IS RESPONSIBLE FOR ANY FEES.
 - CONTRACTOR IS RESPONSIBLE FOR DAMAGE TO ANY EXISTING ITEM AND/OR MATERIAL DUE TO CONSTRUCTION OPERATIONS. ALL STREET SURFACES, UTILITY POLES, CULVERTS, DITCHES, CURB AND GUTTER OR OTHER STRUCTURES THAT ARE DISTURBED OR DAMAGED IN ANY MANNER AS A RESULT OF CONSTRUCTION SHALL BE REPLACED OR REPAIRED BY THE CONTRACTOR IN ACCORDANCE WITH THE APPROPRIATE SPECIFICATIONS.
 - IF DEPARTURES FROM THE DRAWINGS OR SPECIFICATIONS ARE DEEMED NECESSARY BY THE CONTRACTOR, DETAILS OF SUCH DEPARTURES AND REASONS THEREOF SHALL BE SUBMITTED IN WRITING TO THE OWNER/DESIGN ENGINEER FOR REVIEW. NO DEPARTURES FROM THE CONTRACT DOCUMENTS WILL BE ALLOWED WITHOUT APPROVAL BY THE OWNER.
 - CONTRACTOR SHALL MAINTAIN AN "AS-BUILT REDLINE" SET OF DRAWINGS TO RECORD THE EXACT LOCATION OF ALL PIPING AND PIPE INVERT ELEVATIONS PRIOR TO CONCEALMENT. DRAWINGS SHALL BE GIVEN TO THE OWNER/DESIGN ENGINEER PRIOR TO COMPLETION OF THE PROJECT.
 - ANY AND ALL QUANTITIES SHOWN OR IMPLIED ON THE PLANS ARE FOR ESTIMATION PURPOSES ONLY.
 - NO SIGHT OBSTRUCTING, OR PARTIALLY OBSTRUCTING WALL, FENCE, FOLIAGE, BERM, SIGN, PARKED VEHICLE, OR OTHER OBJECT BETWEEN THE HEIGHTS OF TWO (2) FEET AND EIGHT (8) FEET ABOVE THE CURB LINE ELEVATION (OR THE EDGE OF PAVEMENT IF NO CURB EXISTS) SHALL BE PLACED WITHIN A SIGHT TRIANGLE.
 - THIS SITE IS NOT IN A SPECIAL FLOOD HAZARD AREA.
 - REFER TO THE PHASE ONE SERENITY DEVELOPMENT PLAN FOR STREET PROFILES, CURB AND GUTTER, CURB RAMP, ASPHALT PAVING, AND CONCRETE SIDEWALK DETAILS.
 - REFER TO THE PHASE ONE SERENITY DEVELOPMENT PLANS FOR STANDARD DETAILS AND SPECIFICATIONS.
 - THE SITE SHALL BE MAINTAINED BY THE SERENITY HOA.
 - HOA SHALL BE RESPONSIBLE FOR THE MAINTENANCE OF THE STORMWATER SYSTEM THAT IS OUTSIDE THE STREET RIGHT OF WAY.
 - LAND USE CLASSIFICATION = COMPACT MIXED USE
 - PINEY GROVE RAWLS RD. IS ON THE HARNETT COUNTY COMPREHENSIVE TRANSPORTATION PLAN.
 - THIS DEVELOPMENT IS WITHIN ONE MILE OF A VOLUNTARY AGRICULTURAL DISTRICT.
 - HOA SHALL BE RESPONSIBLE FOR MAINTENANCE OF THE PARKING AREAS, DRIVE AISLES, AND ALL LANDSCAPE BUFFERING.
 - PERMANENT SIGN SHOULD BE SETBACK AT LEAST 10' FROM NCDOT RIGHT-OF-WAY, AND WILL REQUIRE AN ADDITIONAL PERMIT & REVIEW.

SITE PLAN NARRATIVE:

THE AMENITY SITE WILL CONSIST OF A CLUBHOUSE AND POOL, POST OFFICE FUNCTIONING AS THE CENTRAL MAIL KIOSK, AND MULTI-USE GREEN SPACE TO INCLUDE A PLAYGROUND, WINDMILL FEATURE, PICNIC AREA, MULTI-PURPOSE FIELD, YOGA AND HAMMOCK PARK. THE ARCHITECTURAL FACADE AND SITE ELEMENTS SHOW CASE THE HOMESTEAD FEEL WITH USE OF NATURAL WOOD FINISHES, DECORATIVE LIGHTING, SPLIT RAIL FENCING, AND STONE MATERIALS.

SEE SERENITY DEVELOPMENT PLAN STORMWATER REPORT FOR COMPLIANCE OF SITE STORMWATER MITIGATION MEASURES.

LEGEND

--- (dashed line)	contour interval per development plan
- - - - (long dashed line)	proposed contour interval
--- (solid line)	sanitary sewer
--- (solid line)	water line
--- (solid line)	decorative board fence
--- (solid line)	decorative split rail fence
--- (solid line)	Right of way
--- (dashed line)	utility easement

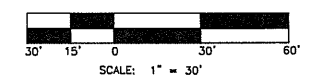

1 SITE PLAN
SCALE: 1" = 30'

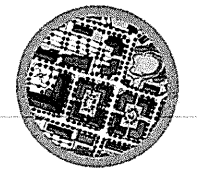

D. CLUGSTON
BUILDING AND DEVELOPMENT CO.

Timmons Group

REVISIONS:

10-14-20	comments revision

SITE PLAN
SERENITY AMENITY
Piney Grove Rawls Rd, Harnett County, NC
GREENFIELD COMMUNITIES

SCALE:
DRAWN BY:
JGB
PROJECT #
18081
DATE:
03/03/20
SHEET

OF C-2.0

TMTLA ASSOCIATES
5011 SOUTH PARK DRIVE, STE. 200 - DURHAM, NC 27713
P: (919) 484-8880 E: info@tmtla.com

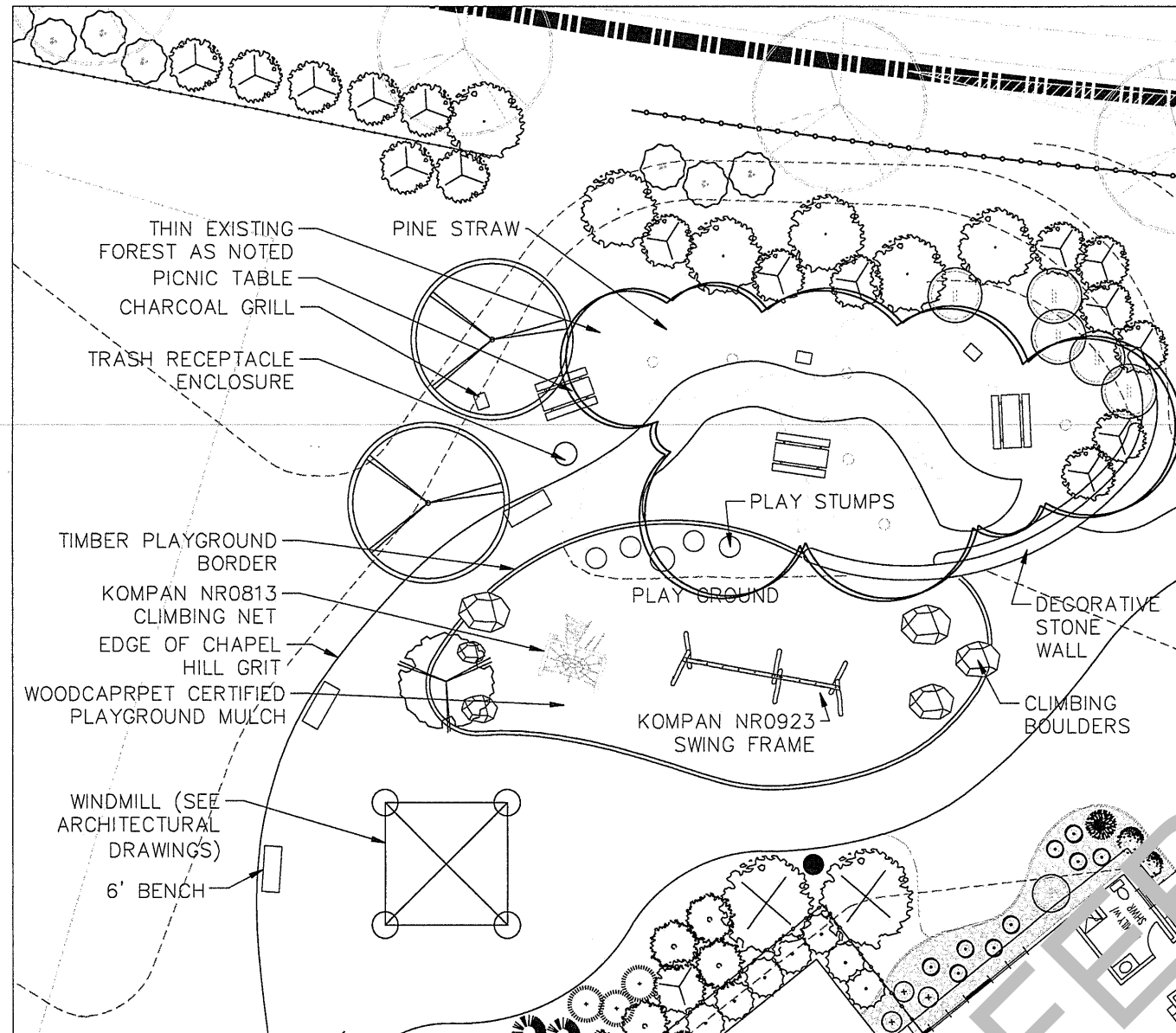

1 ENLARGEMENT
SCALE: 1" = 10'

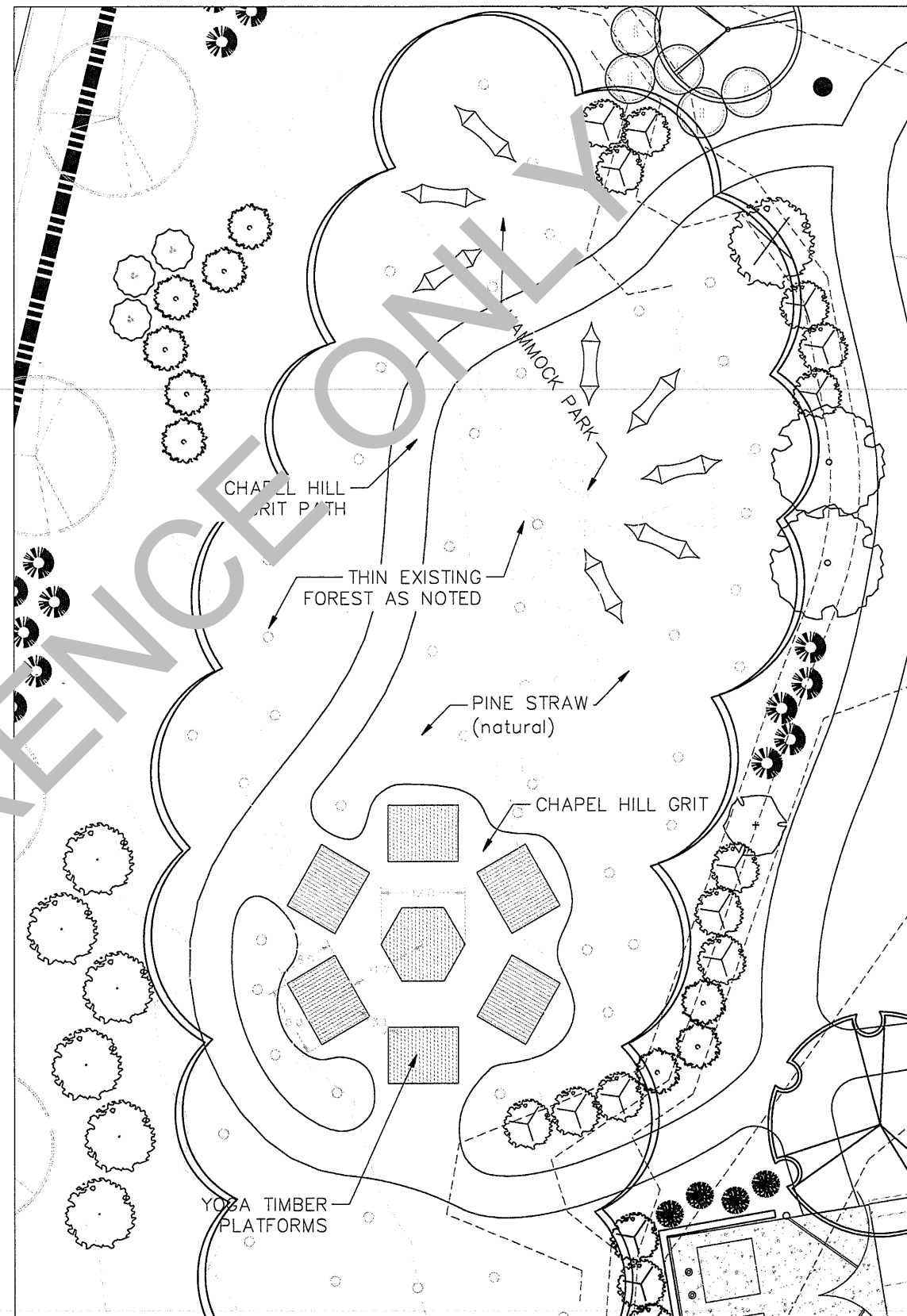

2 ENLARGEMENT
SCALE: 1" = 10'

- GENERAL NOTES:
1. PLAY EQUIPMENT TO BE INSTALLED PER MANUFACTURER SPECIFICATIONS.
 2. PLAYGROUND AREA TO BE COVERED WITH WOODCAPRET CERTIFIED PLAY GROUND MULCH.
 3. SEE DETAILS SEE FOR FURNISHINGS AND SPECIFICATIONS.
 4. SEE LANDSCAPE SHEET FOR FOREST THINNING REQUIREMENTS.
 5. PLAYGROUND EQUIPMENT SUBJECT TO CHANGE.



Know what's below.
Call before you dig.

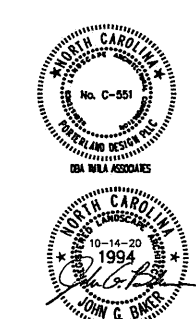
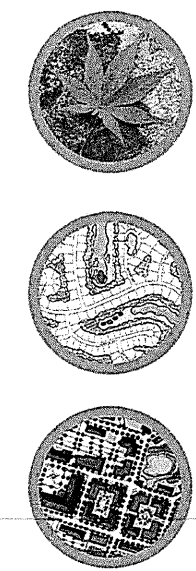
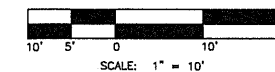
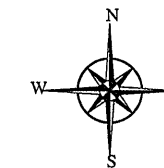

TMTLA ASSOCIATES
5011 SOUTH PARK DRIVE, STE. 200 - DURHAM, NC 27713
P: (919) 484-8880 e: info@tmtla.com

D. CLUGSTON
BUILDING AND DEVELOPMENT CO.

Timmons Group

REVISIONS:

10-14-20	comments revision

PARKS ENLARGEMENT
SERENITY CLUBHOUSE
Piney Grove Rawls Rd. Harnett County, NC
GREENFIELD COMMUNITIES

SCALE: _____
DRAWN BY: JGB
PROJECT # 18081
DATE: 03/03/20
SHEET

OF **C-2.1**

C:\projects\serenityclubhouse\parks\parks_enlargement.dwg, 2/27/2020 11:27:24 AM, DWG TO PDF

THE AERMOTOR WINDMILL

MADE IN THE U.S.A.

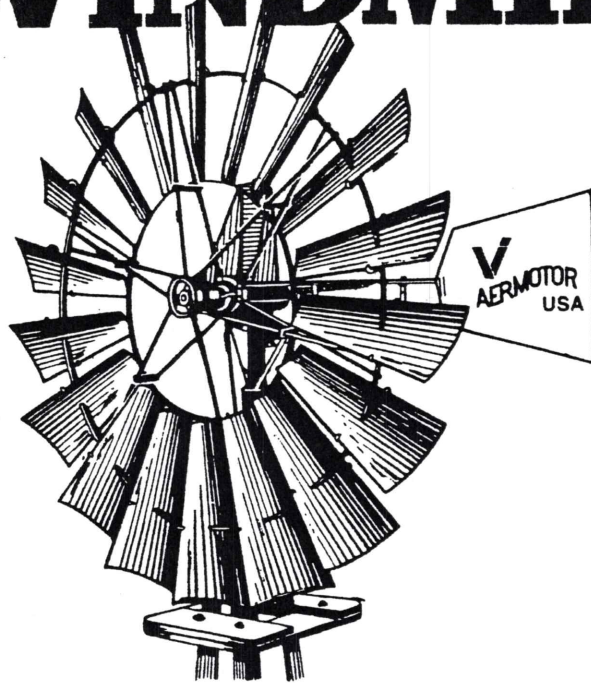

Very few refinements have been necessary in the time-proven Aermotor Windmill of 1888, a pumping machine proven to be the most energy efficient pump ever invented. The Aermotor Windmill, built in the USA with American technology, materials and labor, will provide years of trouble-free service, and pumping capacities for almost any rural application.

The Aermotor Windmill features:

- *Precisely balanced and aligned wheel design.*
- *Oil reservoir to supply oil liberally to all gears and bearings.*
- *Double gears and Pitmans for balanced loading.*
- *Automatic regulation to turn the wheel out of strong winds.*
- *Outside furling device.*
- *Adjustable brake.*
- *Adjustable stroke to vary volume or elevation.*

C A P A C I T I E S

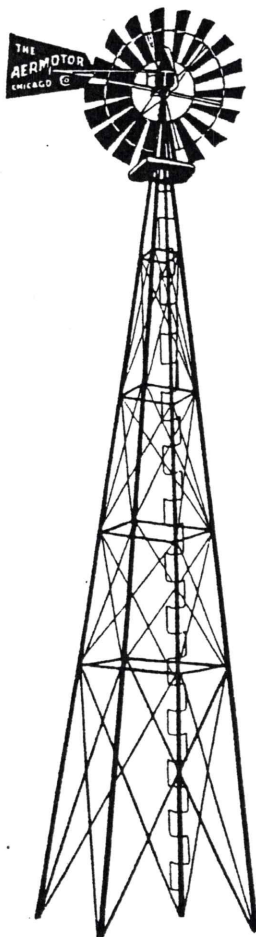

DIAMETER OF CYLINDER IN INCHES	CAPACITY PER HOUR IN GALLONS	Total Elevation in Feet							
		SIZE							
		6 Ft	8-16 Ft	6 Ft	8 Ft	10 Ft	12 Ft	14 Ft	16 Ft
1 3/4	105	150	130	185	280	420	600	1,000	
1 7/8	125	180	120	175	260	390	560	920	
2	130	190	95	140	215	320	460	750	
2 1/4	180	260	77	112	170	250	360	590	
2 1/2	225	325	65	94	140	210	300	490	
2 3/4	265	385	56	80	120	180	260	425	
3	320	470	47	68	100	155	220	360	
3 1/4	—	550	—	—	88	130	185	305	
3 1/2	440	640	35	50	76	115	160	265	
3 3/4	—	730	—	—	65	98	143	230	
4	570	830	27	39	58	86	125	200	
4 1/4	—	940	—	—	51	76	110	180	
4 1/2	725	1,050	21	30	46	68	98	160	
4 3/4	—	1,170	—	—	—	61	88	140	
5	900	1,300	17	25	37	55	80	130	
5 3/4	—	1,700	—	—	—	40	60	100	
6	—	1,875	—	17	25	38	55	85	
7	—	2,550	—	—	19	28	41	65	
8	—	3,300	—	—	14	22	31	50	

Capacities shown in the above table are approximate, based on the mill set on the long stroke, operating in a 15 to 20 mile-an-hour wind. The short stroke increases elevation by one-third and reduces pumping capacity one-fourth.

INDEX OF CONTENTS	Page
Windmill Specifications	2
Assembly of Stub Tower	3
Assembly of Sail Sections	4
Assembling the Windmill	5
Exploded View of Windmill Parts	11
Changing Mill to Short Stroke	13
Oiling and Care of Windmill	14
Replacement of Hub and Shaft	15
Replacement of 752 Bearing	16
Replacement of 523 Guide Wheel	16
Problems—Cause—Remedy	16
Windmill Maintenance Program	18
Cylinders	22
Engineering Data	25

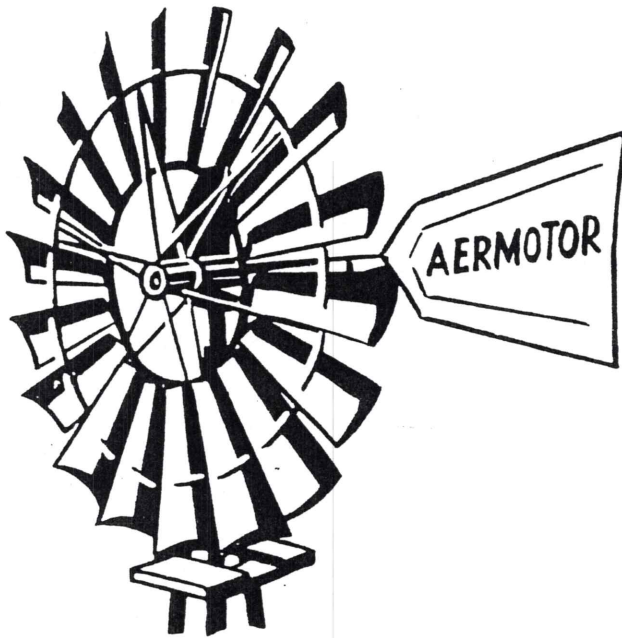

INSTALLATION, OPERATING AND MAINTENANCE INSTRUCTIONS

AERMOTOR WINDMILLS



California Contractor's License #620131

PAUL PETROCCHI
ELLEN SATTLER
530-644-3008 / 800-494-6364

POST OFFICE BOX 1187
DIAMOND SPRINGS
CALIFORNIA 95619

www.windmills.net

OWNER'S RECORD

WINDMILL SIZE 6, 8, 10, 12, 14, 16,
(Circle the size)

DATE CODE _____

DATE OF INSTALLATION _____

DEPTH TO CYLINDER _____

SIZE OF CYLINDER _____

DROP PIPE SIZE _____

PUMP ROD SIZE _____

OWNER _____

INSTALLER _____

It is important to use a tower high enough for good wind exposure from every direction. The mill will pump more often, and will be safer in storms. The wheel should be at least 15 feet above all surrounding wind obstructions, such as buildings and trees, within a radius of 400 feet.

Please read thoroughly these instructions BEFORE attempting to install your AERMOTOR WINDMILL. It can not only save you time but also enable you to get the maximum performance from your windmill.

HOW TO INSTALL THE AERMOTOR WINDMILL

General Information and Precautions

It is recommended that there be at least two men, working together on the installation, to save time and make the job easier and safer.

As in any installation of this type, safety is extremely important. If proper safety measures are not taken, it can result in severe physical impairment, or even loss of life, not only to the workers but to innocent bystanders as well.

WE STRONGLY RECOMMEND THAT THE FOLLOWING SAFETY PRECAUTIONS BE TAKEN FOR THE PERSONAL SAFETY OF EACH WORKER AND THE SAFETY OF ANYONE NEAR THE TOWER WHILE WORK IS IN PROGRESS:

1. Wear approved (construction type) hard hats.
2. Wear and use approved safety belts.
3. Wear safety shoes having steel toes and rubber or cork soles and heels.

4. Avoid wearing loose-fitting or torn clothing which might snag on a steel member of the tower.
5. Be certain that shovels, iron bars and tools are located a distance away from the tower when they are not in use.
6. Be certain that all bolts and nuts are secure at each level of tower construction before standing or climbing on that section.
7. Make certain that there are no overhead electrical lines nearby that could come into contact with tower or windmill.

When these safety precautions have been taken, you are now ready to begin the assembly and installation of your windmill.

AERMOTOR WINDMILL SPECIFICATIONS

Model 802*	Mill Size Wheel Dia. (Ft.)	Stroke Inches		No. Of Sails	Mill Ship'g Weight (Pounds)	Back Geared	Max. Strokes Per Minute	At Wind Velocity	Max. Wheel RPM	Weight Of Crated Motor
		Long	Short							
X	6	5"	3¾"	18	210	3.91-1	32	15-18 mph	125	100
A	8	7½"	5½"	18	355	3.29-1	32	15-18 mph	105	175
B	10	9¼"	7¼"	18	655	3.29-1	26	15-18 mph	85	330
D	12	11¼"	8¼"	18	1130	3.50-1	21	18-20 mph	73	540
E	14	13½"	9¾"	18	1870	3.43-1	18	18-20 mph	62	805
F	16	14¾"	11¾"	18	2585	3.29-1	16	18-20 mph	53	1180

*Model 802 Windmills were introduced in 1981 and parts are interchangeable with Model 702 Windmills introduced in 1933.

INSTALLATION INSTRUCTIONS

AERMOTOR WINDMILL TOWERS

STANDARD
4-POST TOWER

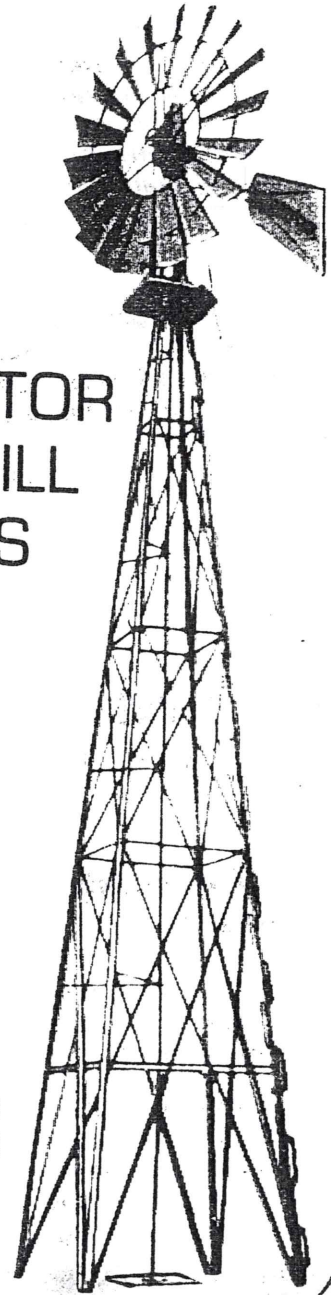

AERMOTOR

A Division of Valley Industries, Inc.

CONWAY, ARKANSAS 72032

It is important to use a tower high enough for good wind exposure from every direction. The mill will pump more often, and will be safer in storms. The wheel should be at least 15 feet above all surrounding wind obstructions, such as buildings and trees, within a radius of 400 feet.

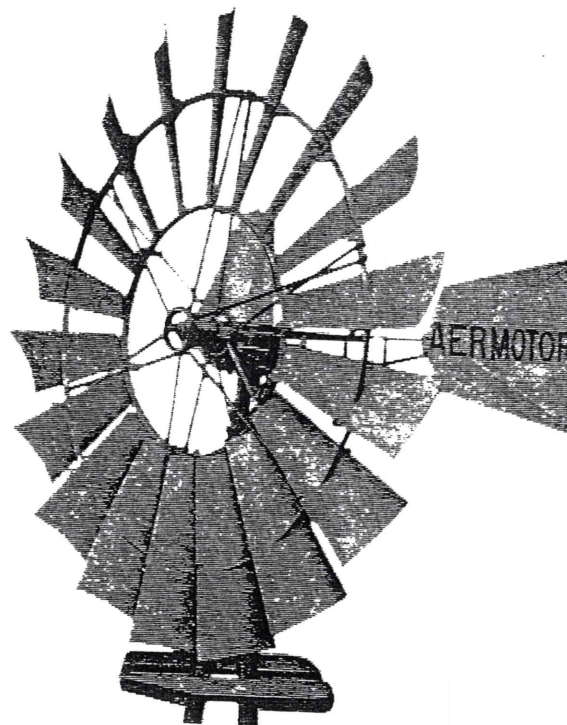

Please read thoroughly these instructions BEFORE attempting to install your AERMOTOR WINDMILL TOWER. It can not only save you time but also enable you to get the maximum performance from your water system.

HOW TO INSTALL THE AERMOTOR STANDARD 4-POST AND WIDESPREAD WINDMILL TOWERS

General Information and Precautions.

It is recommended that there be at least two men, working together on the installation, to save time and make the job easier and safer.

As in any installation of this type, safety is extremely important. If proper safety measures are not taken, it can result in severe physical impairment, or even loss of life, not only to the workers but to innocent bystanders as well.

WE STRONGLY RECOMMEND THAT THE FOLLOWING SAFETY PRECAUTIONS BE TAKEN FOR THE PERSONAL SAFETY OF EACH WORKER AND THE SAFETY OF ANYONE NEAR THE TOWER WHILE WORK IS IN PROGRESS:

1. Wear approved (construction type) hard hats.
2. Wear and use approved safety belts.
3. Wear safety shoes having steel toes and rubber or cork soles and heels.
4. Avoid wearing loose-fitting or torn clothing which might snag on a steel member of the tower.
5. Be certain that shovels, iron bars and tools are located a distance away from the tower when they are not in use.

6. Be certain that all bolts and nuts are secure at each level of tower construction before standing or climbing on that section.
7. Make certain that there are no overhead electrical lines nearby that could come into contact with tower or windmill.

When these safety precautions have been taken, you are now ready to begin the assembly and installation of your tower.

Methods of Assembling A Standard 4-Post Tower.

Your Aermotor windmill tower can be built complete on the ground and hoisted into place by means of a crane, boom truck or similar equipment.

It can also be built, section by section, from the ground up.

The method selected will depend largely upon the experience of the installer. If you elect to build the tower on the ground, care should be taken to pre-

vent the bending of the corner posts when the tower is hoisted into position. Temporary bracing, installed near the bottom of the lower corner posts, will help to prevent bending until the tower can be securely anchored in place.

Aermotor towers are so designed that they can be built from the ground up. All girts are located just below the splice of the corner posts so that the installer, who is standing on planks at any set of girts, can build the section above.

It is recommended that the planks used as scaffolding be at least 2" x 12" of solid, sound material and placed on the girts as close to the corner posts as possible so that the girts will not sag in the middle.

Lay two (2) planks on **each side** in one direction and two (2) planks each on the opposite sides, over the first planks, in the other direction (total of 8 planks, See Figure 6). Leave them in place as each section is completed so that you can return to the lower section for tightening bolts. It will also enable

you to store your material for the next section of the tower to be built.

Check Your Material.

Open the bundles of tower materials and group similar pieces together. Open the bolt box and separate the different sizes. Check everything against the Components Listing to see that you have the parts you need to do your job.

On towers for 8-foot and 10-foot mills, the regular corner posts are 13 feet, 8½ inches long and extend over two panels of the tower. For 27-foot and 40-foot widespread towers, the bottom corner posts are 7 feet long.

The top corner posts for 21-foot, 33-foot and 47-foot towers are 7 feet long. For widespread towers for 12-foot, 14-foot and 16-foot mills, they are also 7 feet long but they are bent slightly just below the platform location.

After the material has been checked, you are ready to begin with the installation.

Components For Aermotor Towers.

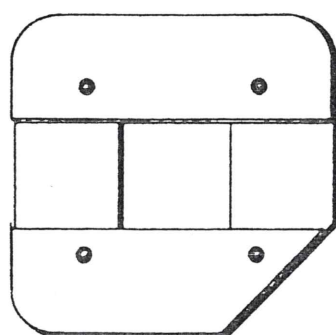

PLATFORM



PLATFORM BOLT

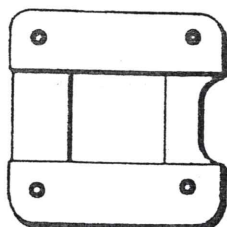

OILING PLATFORM
(For Widespread Towers
only with 12-ft., 14-ft.,
16-ft. Mills)

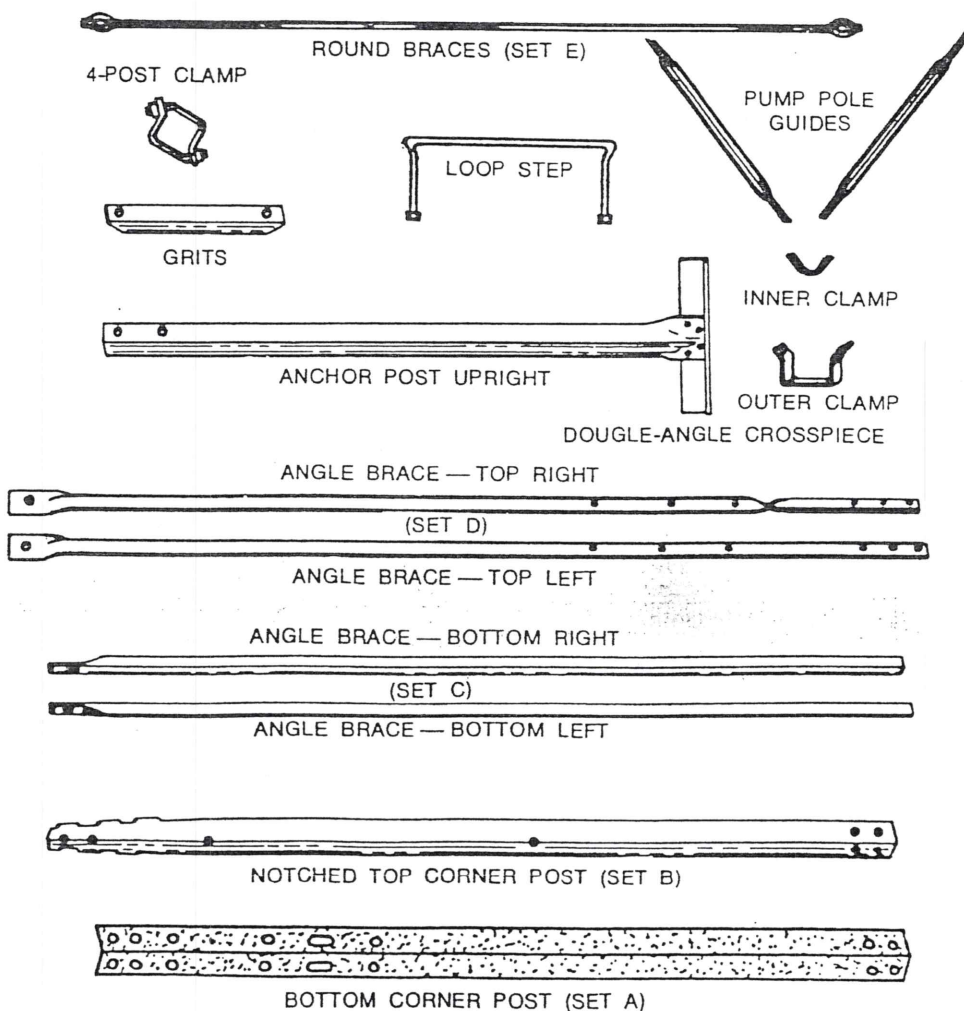

BOLT LISTS FOR 4-POST STANDARD TOWERS FOR 6 OR 8 FOOT AND 10 FOOT MILLS

Where Used	SIZE OF TOWER		HEIGHT OF TOWERS — FEET							
	10 Foot	6 or 8 Foot	7	14	20	21	27	33	40	47
Angle Brace, Cross	3/8 x 3/4"	3/8 x 3/4"	—	—	—	4	4	4	4	4
Corner Posts	3/8 x 3/4"	3/8 x 3/4"	17	33	50	17	34	50	50	67
Angle Braces	3/8 x 1"	3/8 x 1"	—	—	—	9	17	17	17	17
Corner Posts	3/8 x 1"	3/8 x 1"	—	—	—	33	—	—	—	—
Anchor Post-Crosspieces	3/8 x 1"	3/8 x 1"	—	—	—	17	17	17	17	17
Girt and 1 Brace	3/8 x 1"	3/8 x 1"	—	17	17	—	9	9	9	9
Girt and 2 Braces	3/8 x 1 1/4"	3/8 x 1 1/4"	—	—	9	—	9	17	25	33
Pipe Base, Short	1/2 x 2"	3/8 x 1 1/2"	2	2	2	2	2	2	2	2
Pipe Base, Long	1/2 x 2 1/2"	3/8 x 1 3/4"	2	2	2	2	2	2	2	2
Pump Pole Splices	3/8 x 2 1/4"	3/8 x 2"	—	—	—	2	4	4	8	8
Tower Top Bolts	3/8 x 4 1/2"	3/8 x 4"	4	4	4	4	4	4	4	4
Pole Splice Straps (Pair)	B-82	A-82	—	—	—	—	1	1	2	2
Pole Connection	B-62	A-62	—	—	1	1	1	1	1	1
Bolts for Pole Connection	3/8 x 2 1/4"	3/8 x 2"	—	—	2	2	2	2	2	2
Washers for Pole Connection	7/16 x 1 x 1/8"	7/16 x 1 x 1/8"	—	—	2	2	2	2	2	2
Pole Guide Clamp, Outer	T-3293	T-3291	—	1	1	1	2	3	4	5
Pole Guide Clamp, Inner	T-3294	T-3292	—	1	1	1	2	3	4	5
Bolts for Pole Guide	1/4 x 1"	1/4 x 1"	—	2	2	2	5	7	9	11
Clamp Complete	T-179 1/2	T-177	1	1	1	1	1	1	1	1
V-Bolt for Furl Handle	A-333	A-334	1	1	1	1	1	1	1	1
Loop Steps	—	U-397	2	7	12	11	17	22	27	32
Loop Steps	U-397	—	1	6	11	10	16	21	26	31

Specifications subject to change without notice.

BOLT LISTS FOR 4-POST WIDE SPREAD TOWERS

Where Used	Size of Mill			Height of Tower, Feet			
	16-ft.	14-ft.	12-ft.	27	33	40	47
Angle Braces	1/2 x 1	3/8 x 3/4	3/8 x 3/4	10	10	10	10
Angle or Truss Brace, Lower End	5/8 x 1 1/2	1/2 x 1 1/4	1/2 x 1 1/4	9	9	9	9
Corner Posts	5/8 x 1 1/4	1/2 x 1	1/2 x 1	57	57	74	74
Girt and 1 Brace	5/8 x 1 1/2	1/2 x 1 1/4	1/2 x 1 1/4	11	11	11	11
Girt and 2 Braces	5/8 x 1 3/4	1/2 x 1 1/2	1/2 x 1 1/2	9	17	25	33
Pipe Base, short	5/8 x 3	1/2 x 2 1/4	1/2 x 2	2	2	2	2
Pipe Base, long	5/8 x 3 1/2	1/2 x 2 1/2	1/2 x 2 1/4	2	2	2	2
Pump Pole Splices	3/8 x 3 1/2	3/8 x 3	3/8 x 2 1/2	4	4	8	8
Tower Top Bolts	5/8 x 7 1/2	1/2 x 6	1/2 x 5 1/2	4	4	4	4
Pole Splice Straps (pair)	F-82	E-82	D-82	1	1	2	2
Pump Connection	—	E-62	D-62	1	1	1	1
Bolts for Pump Connection	—	1/2 x 3	1/2 x 2 3/4	2	2	2	2
Washers for Pump Connection	—	9/16 x 1 1/4	9/16 x 1 1/4	2	2	2	2
Pole Guide Clamp, outer	T-3491	T-3393	T-3391	2	3	4	5
Pole Guide Clamp, inner	T-3492	T-3394	T-3392	2	3	4	5
Bolts for Pole Guide	3/8 x 1 1/4	1/4 x 1	1/4 x 1	5	7	9	11
Clamp Complete	T-777	T-274	T-277	1	1	1	1
V Bolt for Furl Handle	—	D-333	D-333	1	1	1	1
V Bolt for Furl Handle	D-333	—	—	2	2	2	2
Steps	—	U-397	U-397	17	22	27	32
Steps	U-397	—	—	16	21	26	31
Truss Braces	—	3/8 x 3/4	3/8 x 3/4	4	4	3	4
Truss Braces	—	3/8 x 1	3/8 x 1	8	8	8	8
Truss Braces	1/2 x 1	—	—	11	11	7	11
Truss Braces	1/2 x 1 1/4	—	—	—	—	4	—
Corner Washer f/Pipe Base Bolts	T-779	—	—	4	4	4	4
Anchor Post-Crosspiece	5/8 x 1 1/2	1/2 x 1 1/4	1/2 x 1 1/4	17	17	17	17

Specifications subject to change without notice.

Anchor Holes.

The anchors are the foundation of your tower so you must exercise care in locating and digging the holes. Determine how you will fill the holes around the anchors. It is recommended that the bottom two feet of the holes be filled with cement and topped with dirt. The holes should be at least two feet in diameter to give a secure foundation for the tower. Refer to Figure 1 for information on locating the holes and to Figure 2 for the proper base dimensions of the tower you plan to build.

For mills of 14-foot diameter, or less, the holes should be 4 feet, 9 inches deep. For 16-foot mills, the holes should be 6 feet, 6 inches deep. Be certain that the bottom of all four holes are on the same level.

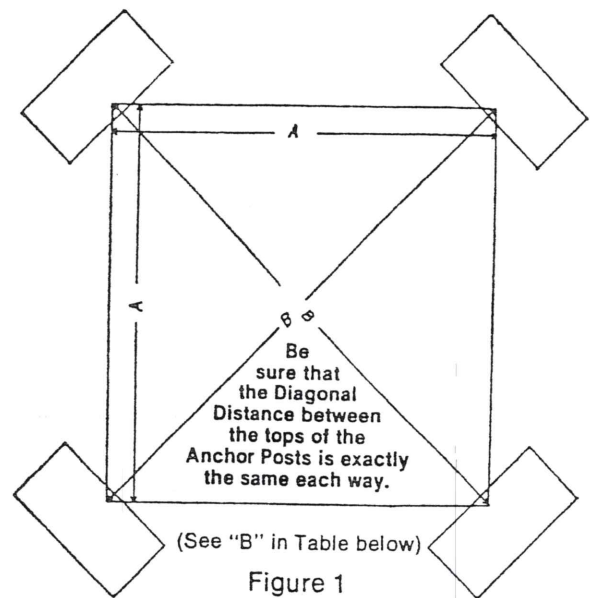

Figure 1

Figure 2 BASE DIMENSIONS... 4-POST TOWERS																
STANDARD TOWER				WIDE-SPREAD TOWER												
FOR 6, 8 and 10-FT. MILLS				12-FT. MILLS				14-FT. MILLS				16-FT. MILLS				
HEIGHT	A		B		A		B		A		B		A		B	
(Feet)	Ft.	In.	Ft.	In.	Ft.	In.	Ft.	In.	Ft.	In.	Ft.	In.	Ft.	In.	Ft.	In.
21	6	0	8	5 ³ / ₁₆	—	—	—	—	—	—	—	—	—	—	—	—
27	5	6 ¹³ / ₁₆	7	10 ¹ / ₂	6	8 ¹ / ₈	9	5 ⁵ / ₁₆	6	8 ¹ / ₄	9	5 ¹ / ₂	—	—	—	—
33	6	10 ³ / ₄	9	9	8	4 ¹ / ₄	11	9 ³ / ₄	8	4 ³ / ₈	11	9 ¹⁵ / ₁₆	8	5 ¹ / ₂	11	11 ⁹ / ₁₆
40	8	2 ¹¹ / ₁₆	11	7 ¹ / ₂	9	11 ⁷ / ₈	14	1 ¹ / ₂	10	0	14	1 ¹¹ / ₁₆	10	1	14	3 ¹ / ₈
47	9	6 ⁵ / ₈	13	6	11	8 ¹ / ₁₆	16	6 ¹ / ₁₆	11	8 ⁹ / ₁₆	16	6 ¹ / ₄	11	9 ¹ / ₈	16	7 ⁹ / ₁₆

Anchor Posts.

Bolt two (2) anchor post crosspieces back to back to the anchor post upright (See Figure 3). Tighten the nuts securely. Put the anchors in the anchor holes BUT DO NOT FILL THE HOLES AT THIS TIME.

Ladder.

Attach the steps to the ladder corner post before you begin assembling the tower in order that you might use them to climb the tower as it is built up.



Loop Steps

Smooth loop steps on the corner post of the tower form a very solid ladder. Greater slope at the corner post makes climbing easy.

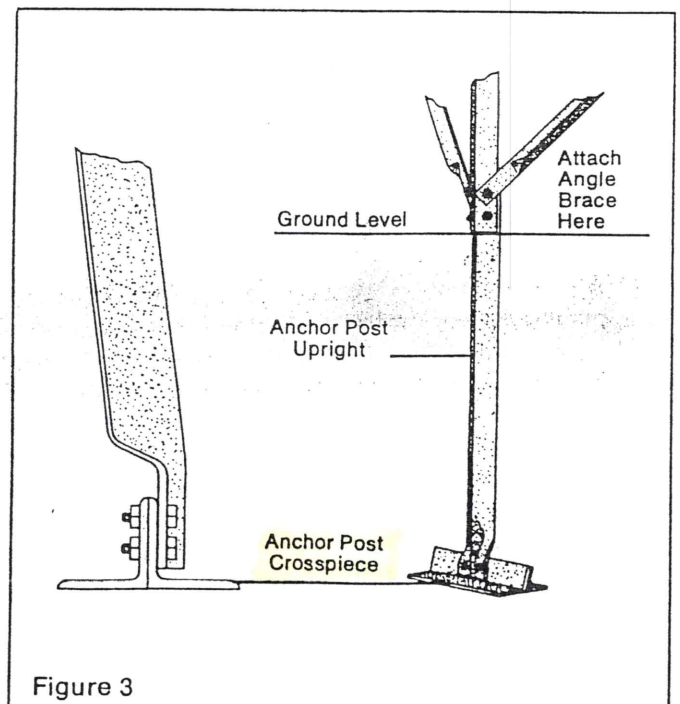

Figure 3

Assembling The First Section.

There are two types of corner posts. (Refer to Components For Aermotor Towers.) Set B, which has notches at the top end, is used at the top of the tower only. Set A is used from the bottom of the tower to the point where the posts join to Set B.

Bolt a corner post (from Set A) to each anchor post upright (the end of the post having two holes).

Install the longest set of girts, **inside** the corner posts, about 7 feet from the ground at the bolt holes provided in the corner posts. Install bolts with the nuts to the outside. Snug but do not tighten.

Install the lower sections of the angle braces, Set C, on the **outside** of the corner posts, bolting the bottom end of the brace to the upper hole of the anchor post splice. These braces are made right hand and left hand so that the flat side of both of them will be up when they are properly attached. Splice the top section of the angle braces, Set D, to Set C at the bottom girt and bolt in place on the corner post at the second girt from the ground. Snug but do not tighten nuts. (See Figure 4 for proper method of crossing and connecting angle braces.) The angle braces have extra holes so that they will fit different tower heights. Attach the top ends of the angle braces at the corner posts with the same bolts that are used to fasten the girts. At the second girt, install a round brace (Set E) at each corner post using the same bolts that are used to fasten the angle braces and girts (See Figure 5). Let the round braces hang free until the next section has been built. Snug the nuts but do not tighten the nuts in any section until the section above has been built.

The Second Section.

When the bottom section has been assembled, lay planks across the girts as close to the corner posts as possible (See Figure 6). Bring up material for the next section and use the planks for storage until the material can be installed in its proper place. Install the girts and fasten the round braces in place. Beginning at the second girt from the ground, the round braces extend diagonally across each tower section to the next highest girt and are used in much the same manner that the angle braces were used in the lower section.

When the second section is completed, return to the section below and tighten all nuts securely.

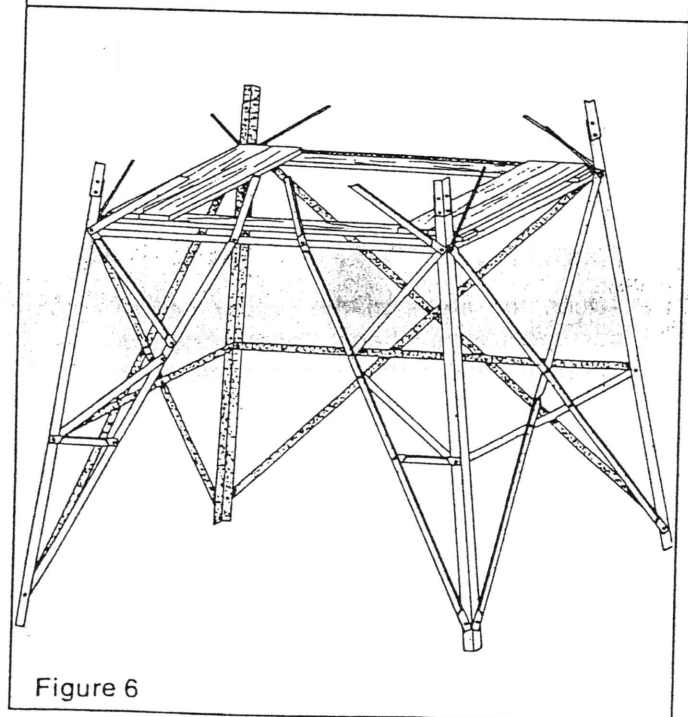
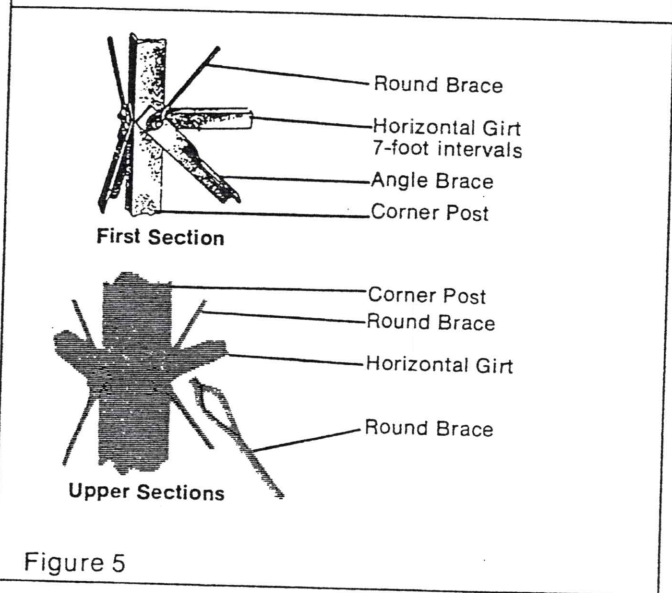
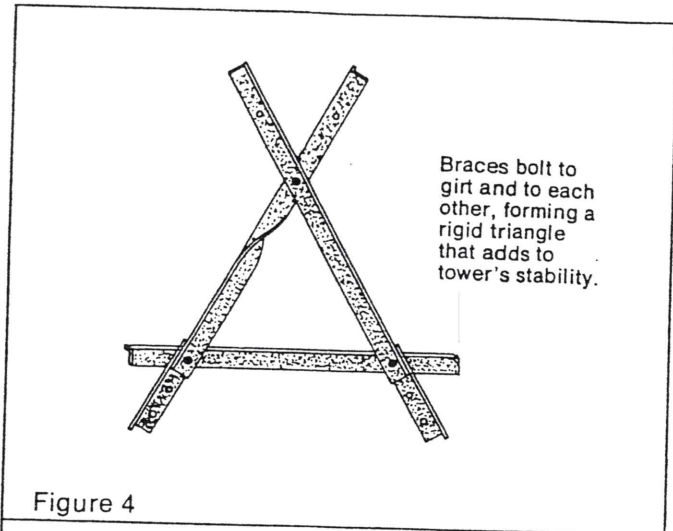

Setting The Anchors.

When two sections of the tower have been assembled, **level the anchor posts carefully**. Be certain that the pump or well casing is in the **exact center of the tower** and that the base of the tower is square. To level the tower, use a straight edge and spirit level on the bottom girts.

To square the tower, measure diagonally across the **tower between the top of the anchor posts**, making certain that the distance is the same in both directions.

When everything is level, plumb and square, fill the anchor holes. It is recommended that cement be used in the bottom two feet of each hole and allowed to set up. Fill the balance of the hole with dirt and tamp it well. **Be certain that the tower does not move when tamping the dirt.**

The Top Of The Tower.

When the top corner posts (Set B) are in position, install the platform (Figure 8) and secure it to the corner posts with four (4) "L" shape bolts. The notched corner of the platform installs at the ladder side of the tower.

Slip the mill mast pipe into position and install the two shorter bolts on that side of the tower to which the furl handle is to be attached. The two longer bolts, which support the furl lever, install on the opposite side.

The furl lever of the mill must be on the opposite side of the tower from the furl handle at the foot of the tower so that the furl wire will pull across the tower and clear the platform.

Be certain to lock the notches at the top of the corner posts, install the clamp and tie bolts, and tighten securely (See Figure 7).

Connect the furl wire to the furl lever at the top of the tower and to the furl handle at the bottom. When the furl handle is all the way down, the furl lever will bear against the nuts at the bottom of the supporting angles.

When both furl rings are in place, installation of the motor can proceed.

Assembling The Mill.

Assemble the tailbone and vane on the ground.

Using a gin pole and tackle, lift the motor to the top of the tower and slip it onto the pipe. Lift the tailbone and vane and attach it to the motor. When

the vane is in place, install the vane spring and pull the mill out of the wind.

Be certain that the furl handle is secure so that there will be no danger of the mill turning into the wind while the wheel is being assembled.

The Wheel.

Preassemble the six sections of the wheel on the ground and install according to the instructions packaged with your mill.

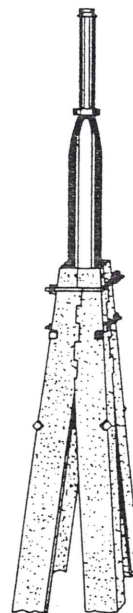

Corner Posts

Notched together for added strength and rigidity.

Figure 7

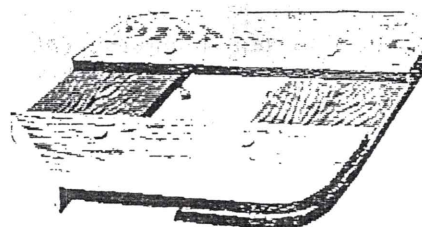

Platform

Heavy lumber, bolted through corner posts. Corner of the platform is cut for easy climbing.

Figure 8

Pump Pole.

Put the pump rod in place and attach the pump pole and pole guides. Each set of guides should be hooked into the oblong holes in the corner posts on the same side of the tower and should be horizontal when the mill is half way up on the stroke. (See Figure 9.) Tighten the nuts so that the clamps will be held firmly to the pump pole, but not so tight as to prevent the pole guides from working freely. A nail or screw, secured into the pole through the hole in the back of the clamp will prevent the clamp from slipping out of position.

Turn the wheel until the pump pole is at the lowest point of the stroke and attach the pump pole connection so that there will be about equal clearance at the top and bottom of the cylinder.

MAKE DOUBLY CERTAIN THAT ALL NUTS ON BOTH THE MILL AND THE TOWER ARE DRAWN UP TIGHT.

WIDESPREAD TOWERS

Installation of widespread towers for 12-foot, 14-foot and 16-foot mills is similar to other standard towers but there are a few exceptions.

These towers have a wider base dimension for a given tower height and one side of the tower is left open for pulling the well by having angle braces that extend up to the second girt. There is no bottom girt on the open side of the tower and truss braces are used to strengthen it.

All of the widespread towers have 7-foot top corner posts which are slightly bent just below the platform. For 27-foot and 40-foot towers, the bottom corner posts are also just 7-feet long.

Widespread towers have heavy channel girts in the tower above the platform to provide solid support for the tackle when pulling the well. The tower components and the windmill are much heavier than the smaller sizes and require special equipment and tackle for lifting them into position.

Widespread towers for 12-foot, 14-foot and 16-foot also have oiling platforms. Install with the cutaway side on the same side of the tower as the long bolts for the pipe base.

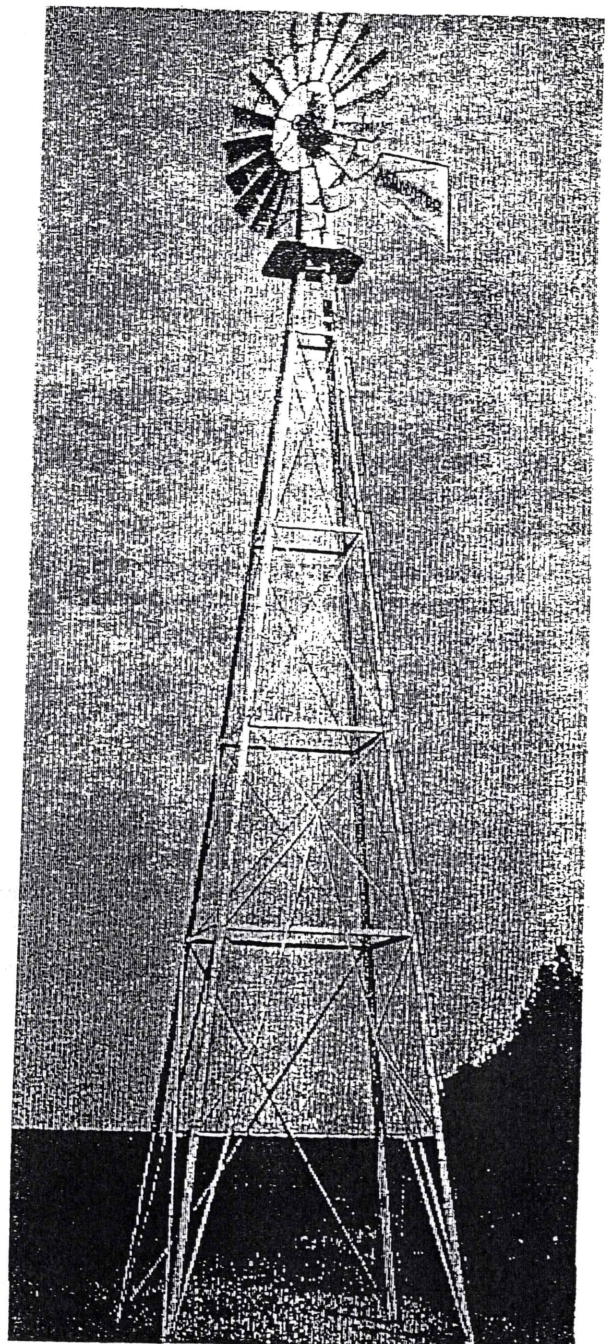
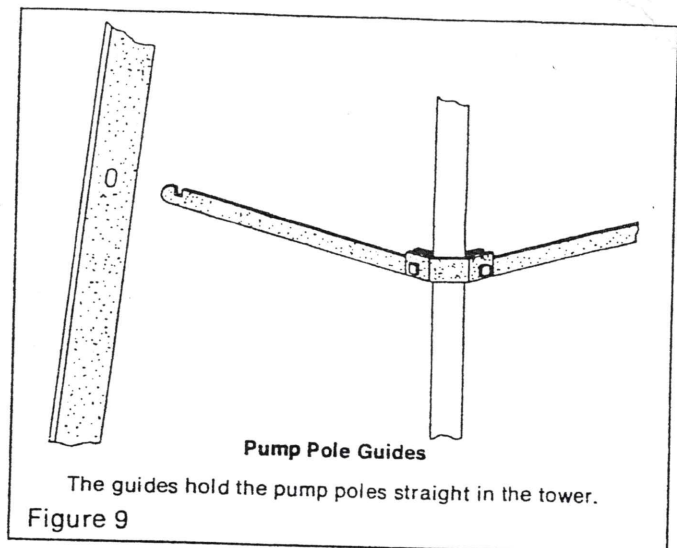

Wide-Spread Towers

One side of the tower is braced so that no horizontal girt interferes with free access to the center of the tower.

