

GENERAL MECHANICAL NOTES

GENERAL REQUIREMENTS:

- MECHANICAL CONTRACTOR IS TO FURNISH AND PAY FOR ALL LABOR, MATERIAL, EQUIPMENT, PERMITS & FEES REQUIRED FOR THE COMPLETE INSTALLATION OF ALL SYSTEMS IN THIS SECTION OF WORK.
- ALL WORK IS TO BE PERFORMED IN ACCORDANCE WITH THE NORTH CAROLINA MECHANICAL CODE AND ALL OTHER APPLICABLE CODES. M.C. IS TO COORDINATE WITH THE G.C. IN REGARDS TO PROJECT TIMELINE, WORK HOURS, AS WELL AS ANY SOUNDING OR INSURANCE REQUIREMENTS.
- ALL MECHANICAL EQUIPMENT SHALL BE PROVIDED COMPLETELY WITH ALL ACCESSORIES, HANGERS, SUPPORTS, CONTROLS, ETC FOR A FULLY FUNCTIONING SYSTEM REGARDLESS OF PRESENCE ON PLANS.
- ALL EQUIPMENT, MATERIALS AND INSTALLATION SHALL BE GUARANTEED TO BE FREE OF DEFECTS FOR A PERIOD OF ONE (1) YEAR AFTER FINAL ACCEPTANCE OF WORK OR IN ACCORDANCE WITH THE MANUFACTURER'S STANDARD GUARANTEE. IF LONGER, ALL COMPRESSORS ARE TO INCLUDE FIVE (5) YEAR WARRANTY. EXISTING EQUIPMENT IS EXCLUDED FROM WARRANTY REQUIREMENT.
- THESE DRAWINGS ARE DIAGRAMMATIC AND SHOW GENERAL LOCATION AND ARRANGEMENT OF ALL MATERIALS AND EQUIPMENT. THE DRAWINGS SHALL BE FOLLOWED AS CLOSELY AS BUILDING CONSTRUCTION AND ALL OTHER WORK WILL PERMIT.
- DO NOT SCALE DRAWINGS FOR MEASUREMENT.
- ALL DUCT DIMENSIONS SHOW ARE INTERIOR DUCT DIMENSIONS.
- INFORMATION GIVEN IN SCHEDULES INCLUDES BOTH DESCRIPTION OF PRODUCT AND MANUFACTURER'S MODEL NUMBER. IF A CONFLICT IS PRESENT BETWEEN THE DESCRIPTION AND MODEL NUMBER, EQUIPMENT DESCRIPTION SHALL TAKE PRECEDENT. IN CASE OF CONFLICT BETWEEN THE PLANS AND NOTES/SPECIFICATIONS OR CONFLICT BETWEEN INFORMATION PRESENTED ON THE PLANS OR IN THE NOTES/SPECIFICATIONS, THEN THE MOST RESTRICTIVE SHALL TAKE PRECEDENT.
- THE M.C. IS RESPONSIBLE FOR CLARIFYING WITH THE G.C. ANY CONFUSION IN REGARDS TO RESPONSIBILITY OF WORK TO BE PERFORMED OR MATERIALS TO BE PROVIDED PRIOR TO SUBMITTING THE BID. THE SUBMITTING OF THE BID BY THE CONTRACTOR WILL BE HELD AS PROOF THAT THE CONTRACTOR UNDERSTANDS THOROUGHLY AND COMPLETELY THE SCOPE OF THE WORK INVOLVED, AND HAS INCLUDED ON THE BID ALL THE NECESSARY ITEMS TO CARRY OUT THIS SECTION OF WORK.
- ALL QUESTIONS MUST BE SUBMITTED IN RFI FORMAT TO THE ARCHITECT AND MUST BE ADDRESSED BY THE APPROPRIATE DESIGNER OF RECORD PRIOR TO BECOMING A PROPOSED CHANGE ORDER.
- UPON COMPLETION OF WORK, THE M.C. IS TO PROVIDE THE OWNER WITH A COMPLETE BOUND SET OF ALL EQUIPMENT OPERATION & MAINTENANCE MANUALS. THE PACKAGE SHALL ALSO INCLUDE ALL APPLICABLE WARRANTY & GUARANTEE INFORMATION.
- M.C. IS TO PROVIDE TRAINING TO OWNER OR OWNER'S REPRESENTATIVE IN REGARDS TO OPERATION, FUNCTION, AND MAINTENANCE OF ALL MECHANICAL EQUIPMENT, CONTROLS, ETC.
- M.C. IS TO REVIEW COMPLETE DRAWING SET. M.C. IS RESPONSIBLE FOR WORK EXPLICITLY SHOWN AND WORK IMPLIED.
- THE M.C. SHALL BE HELD TO HAVE REVIEWED ALL SHEETS OF THE ENTIRE CONTRACT DOCUMENTS, INCLUDING ALL TRADES ARCHITECTURAL, PLUMBING ELECTRICAL, FIRE PROTECTION, AV/DATA, STRUCTURAL, INTERIORS, ETC AND WILL BE RESPONSIBLE FOR PERFORMING ALL WORK INDICED ON ANY SHEET. THE M.C. WILL BE RESPONSIBLE FOR COORDINATING THEIR WORK WITH THE WORK OF OTHERS.
- THE M.C. SHALL FIELD VERIFY EXISTING CONDITIONS PRIOR TO STARTING WORK AND ADJUST DUCTWORK, ETC. TO CORRESPOND TO THE EXISTING CONDITIONS AS REQUIRED.
- M.C. TO COORDINATE WITH G.C FOR MOUNTING FRAMES, ROOF CURBS, ACCESS PANELS AND ANY OTHER WORK THAT NEEDS INTERDISCIPLINE COORDINATION.
- ALL FRESH AIR INTAKES SHALL BE A MINIMUM OF 10 FT. FROM ALL EXHAUST TERMINATIONS IN COMPLIANCE WITH THE LOCAL BUILDING MECHANICAL CODE.
- ALL EQUIPMENT, DUCT, PIPING, ETC EXPOSED INSIDE OR OUTSIDE OF THE BUILDING SHALL BE PAINTED WITH COLOR AS SELECTED BY ARCHITECT WHERE REQUESTED.
- ALL EXPOSED DUCT SHALL BE INTERNALLY INSULATED DOUBLE WALL SPIRAL DUCT WORK.
- ALL CONCEALED DUCT WORK SHALL BE EXTERNALLY INSULATED.
- ALL GREASE DUCT SHALL BE INSULATED WITH FIRE WRAP AS REQUIRED BY THE LOCAL MECHANICAL CODE IF CLEARANCE TO COMBUSTIBLES CAN NOT BE MAINTAINED.
- DISHWASHER UTILIZED SHALL BE A LOW TEMPERATURE DISHWASHER. THE HEAT AND MOISTURE LOADS HAVE BEEN INCLUDED IN THE HVAC CALCULATIONS.
- ALL ROOFING WORK TO BE PERFORMED BY LANDLORDS ROOFING CONTRACTOR.

DIVISION OF WORK:

- ALL ROOF WORK INCLUDING PENETRATIONS, OPENINGS, FLASHING, CURB INSTALLS, ETC. ARE TO BE PERFORMED BY THE ROOFING CONTRACTOR. THE M.C. IS RESPONSIBLE FOR PROVIDING ANY ROOF CURBS, EQUIPMENT RAILS, VENTS, ETC. AND COMMUNICATING ALL REQUIREMENTS WITH THE G.C. AND ROOFING CONTRACTOR PRIOR TO PERFORMING WORK.
- ALL LOW VOLTAGE WIRING RELATED TO MECHANICAL EQUIPMENT AND SYSTEMS IS THE RESPONSIBILITY OF THE M.C. ANY LOW VOLTAGE FIRE ALARM WIRING TO BE BY E.C. THE E.C. SHALL PROVIDE AND INSTALL ALL HIGH VOLTAGE CONNECTIONS TO MECHANICAL EQUIPMENT.
- MECHANICAL CONTRACTOR SHALL EMPLOY THE SERVICES OF THE G.C. FOR CUTTING AND PATCHING OF WALLS, FLOORS AND CEILINGS RELATED TO THE INSTALLATION OF MECHANICAL EQUIPMENT AND SYSTEMS.
- THE G.C. IS RESPONSIBLE FOR PAINTING OF ANY EXPOSED DUCTWORK, PIPING, GRILLES, ETC. THE M.C. IS RESPONSIBLE FOR CLEANING AND PREPARING ITEMS FOR PAINT. M.C. SHALL COORDINATE ALL FIELD PAINTED EQUIPMENT AND ACCESSORIES WITH THE G.C. PRIOR TO PERFORMING WORK.
- THE G.C. SHALL BE RESPONSIBLE FOR PROVIDING AND INSTALLING ANY ACCESS PLATFORMS, GUARD RAILS, LADDERS, CONCRETE PADS, ETC. THE M.C. SHALL COMMUNICATE ALL REQUIREMENTS WITH THE G.C. PRIOR TO PERFORMING WORK.

COORDINATION:

- THE MECHANICAL CONTRACTOR SHALL COORDINATE CLOSELY WITH ALL OTHER TRADES TO AVOID CONFLICT AND ENSURE OTHER TRADES PROVIDE MEASURES TO ACCOMMODATE MECHANICAL WORK (I.E. ACCESS DOORS, SLABWALL/ROOF OPENINGS, ELECTRICAL CONNECTIONS, ETC).
- THE M.C. SHALL COORDINATE LOCATION OF ALL ROOF PENETRATIONS WITH THE ROOFING CONTRACTOR. THE P.C. AND M.C. SHALL COORDINATE LOCATIONS OF NEW PLUMBING VENTS AND EXHAUST TO ENSURE THAT NO PLUMBING VENTS OR ANY OTHER SOURCES OF BUILDING EXHAUST ARE LOCATED WITHIN 10' OF ANY OUTSIDE AIR INTAKES.

MATERIALS:

- ALL MATERIALS SHALL BE NEW UNLESS OTHERWISE SHOWN OR SPECIFIED.
- PROVIDE HANGERS AND SUPPORTS APPROVED FOR USE BY APPLICABLE MECHANICAL CODE.
- ALL MAIN DUCTWORK (SUPPLY, RETURN, EXHAUST) SHALL BE GALVANIZED SHEET METAL CONSTRUCTED IN ACCORDANCE WITH SMACNA STANDARDS.
- ALL FLEXIBLE DUCTWORK SHALL BE LIMITED TO 5FT MAX. AND SHALL BE SUPPORTED AT THE MIDPOINT.
- ALL DIFFUSER AND GRILLE CONNECTIONS SHALL HAVE A RIGID 90° ELBOW PRIOR TO CONNECTION. FLEXIBLE DUCTWORK SHALL NOT CONNECT DIRECTLY TO THE DIFFUSER/GRILLE NECK.
- ALL SUPPLY AND RETURN DUCTWORK SHALL BE INSULATED. INSULATION OF DUCTWORK IN UNCONDITIONED SPACE SHALL BE MINIMUM REQUIREMENTS SET FORTH BY THE APPLICABLE ENERGY CONSERVATION CODE.
- CONCEALED SHEET METAL SUPPLY & RETURN DUCT SHALL BE EXTERNALLY INSULATED WITH MINERAL FIBER BOARD OR BLANKET.
- ALL MAIN DUCTWORK (INCLUDING EXHAUST) SHALL BE SEALED ACCORDING TO THE APPLICABLE

- ENERGY CONSERVATION CODE TO SEAL CLASS C. AT A MINIMUM, INCLUDE SEALING OF ALL DUCT SEAMS WITH NON-HARDENING MASTIC. SEALING BY TAPE ALONE SHALL NOT BE ALLOWED.
- ALL DAMPERS TO INCLUDE SET SCREW OR SIMILAR FEATURE FOR LOCKING IN POSITION. ALL DAMPERS INSTALLED IN INSULATED DUCTWORK SHALL HAVE STANDOFFS FOR DAMPER OPERATION OUTSIDE OF THE INSULATION.
- ALL PROGRAMMABLE THERMOSTATS TO INCLUDE BATTERY BACK-UP AND SHALL INITIALLY BE PROGRAMMED TO THE FOLLOWING ADJUSTABLE SETTINGS:
 - HEATING (OCCUPIED) = 70°F
 - HEATING (UNOCCUPIED) = 65°F
 - COOLING (OCCUPIED) = 75°F
 - COOLING (UNOCCUPIED) = 80°F
- THERMOSTAT SCHEDULES SHALL BE SET TO RUN "BUILDING WARM UP" BY PROGRAMMING THE OCCUPIED SETPOINTS TO BEGIN ONE HOUR PRIOR TO ACTUAL BUILDING OCCUPANCY (EXAMPLE: CHANGE THE HEATING SETPOINT FROM 65°F TO 70°F AT 6AM IF THE SPACE IS NORMALLY OCCUPIED AT 7AM).
- FOR ALL REMOVED EQUIPMENT CONTRACTOR SHALL REMOVE ALL SUPPORTS, HANGERS, CONTROLS, PIPING, UTILITIES, ETC.
- THE MECHANICAL DRAWINGS INDICATE THE GENERAL DESIGN AND ARRANGEMENT OF PIPING, EQUIPMENT, SYSTEMS, ETC. INFORMATION SHOWN IS DIAGRAMMATIC IN CHARACTER AND DOES NOT INDICATE EVERY REQUIRED OFFSET, FITTING, ETC.
- THE LOCATIONS OF THE ITEMS SHOWN ON THE DRAWINGS OR CALLED FOR IN THE SPECIFICATIONS THAT ARE NOT DEFINITELY FIXED BY DIMENSIONS ARE APPROXIMATE ONLY. THE EXACT LOCATIONS NECESSARY TO SECURE THE BEST CONDITIONS AND RESULTS MUST BE DETERMINED BY THE PROJECT SITE CONDITIONS AND SHALL HAVE THE APPROVAL OF THE ENGINEER BEFORE BEING INSTALLED. DO NOT SCALE THE DRAWINGS (UNLESS NOTED OTHERWISE).
- CONTRACTOR SHALL FIELD VERIFY LOCATIONS AND SIZES OF ALL EXISTING EQUIPMENT, DUCTWORK, PIPING, ELECTRICAL CONDUIT, STRUCTURAL MEMBERS, ETC. PRIOR TO BID. CONTRACTOR SHALL NOTIFY ENGINEER OF ANY AND ALL DISCREPANCIES BETWEEN FIELD CONDITIONS AND CONTRACT DRAWINGS.
- ALL DUCTWORK, PIPING AND EQUIPMENT SUPPORTED FROM STRUCTURAL STEEL SHALL BE COORDINATED WITH THE G.C. ALL ATTACHMENTS TO STEEL: BAY JOISTS, TRUSSES, OR JOIST GIRDERS, SHALL BE AT PANEL POINTS. PROVIDE BEAM CLAMPS MEETING MSS STANDARDS. WELDING TO STRUCTURAL MEMBERS SHALL NOT BE PERMITTED. THE USE OF C-CLAMPS SHALL NOT BE PERMITTED.
- MECHANICAL EQUIPMENT, DUCTWORK, AND PIPING SHALL NOT BE SUPPORTED FROM METAL DECK.
- BOXES SHALL BE PROVIDED WHEREVER DUCTS PASS THROUGH FLOOR, WALL AND ROOF CONSTRUCTION.
- WHERE HORIZONTAL DUCTS PASS THROUGH WALLS AND VERTICAL DUCTS PASS THROUGH FLOORS OR ROOFS, SEAL OFF VOID BETWEEN OPENING AND DUCT, WITH AN APPROVED NON-COMBUSTIBLE MATERIAL.
- FURNISH AND INSTALL ALL FOUNDATIONS, BASES AND SUPPORTS.
- LEAK TEST ALL DUCTWORK SYSTEMS PRIOR TO CONCEALMENT.
- PROVIDE VIBRATION ISOLATION FOR ALL MECHANICAL EQUIPMENT TO PREVENT TRANSMISSION OF VIBRATION TO BUILDING STRUCTURE.
- VALVES AND CLEANOUTS SHALL BE INSTALLED AS SHOWN ON THE DRAWINGS AND AS REQUIRED BY CODE.
- PROVIDE ACCESS PANELS FOR INSTALLATION IN WALLS AND CEILINGS, WHERE REQUIRED, TO SERVICE DAMPERS, VALVES, SMOKE DETECTORS, AND OTHER CONCEALED MECHANICAL EQUIPMENT. ACCESS PANELS SHALL BE TURNED OVER TO GENERAL CONTRACTOR FOR INSTALLATION.
- ALL OPENINGS IN FIREWALLS DUE TO DUCTWORK, PIPING, CONDUIT, ETC. SHALL BE FIRE STOPPED WITH A PRODUCT SIMILAR TO 3M OR APPROVED EQUAL.
- ALL AIR CONDITIONING CONDENSATE DRAIN LINES FROM EACH AIR HANDLING UNIT AND ROOFTOP UNIT SHALL BE FIELD FULL SIZE OF THE UNIT DRAIN OUTLET, WITH A P-TRAP, AND PIPED TO NEAREST DRAIN. PROVIDE A CONDENSATE PUMP IF REQUIRED, FIELD VERIFY.
- ALL DUCTWORK SHALL CLEAR DOORS AND WINDOWS.

EXCEPTION:

- M.C. TO FOLLOW MANUFACTURER'S INSTRUCTIONS WHEN INSTALLING MECHANICAL EQUIPMENT. ENGINEER REQUIRED FOR ANY ACCESS AND CLEARANCES ARE MAINTAINED. IF CONFLICT EXISTS BETWEEN THESE PLANS AND MFG INSTRUCTIONS CONTACT ENGINEER.
- ALL PENETRATIONS THROUGH EXTERIOR WALLS AND ROOF SHALL BE FLASHED AND COUNTER-FLASHED IN A WATERPROOF MANNER.
- INSTALL ALL CONTROL DEVICES, INCLUDING THERMOSTATS AND SWITCHES, 4'-0" ABOVE FINISHED FLOOR.
- AN INDEPENDENTLY CERTIFIED TEST AND BALANCE CONTRACTOR SHALL BALANCE SYSTEM TO AIR QUANTITIES INDICATED ON PLANS AND IN ACCORDANCE WITH THE APPLICABLE ENERGY CONSERVATION CODE. THE M.C. SHALL PROVIDE THE OWNER'S REPRESENTATIVE & ENGINEER WITH COMPLETE BALANCE REPORT. THE M.C. IS RESPONSIBLE FOR PROVIDING ANY DAMPERS, VALVES, PORTS, ETC. NECESSARY FOR A COMPLETE SYSTEM BALANCE.
- ANY NOTCHING, DRILLING, BORING OR OTHER ALTERATION TO BUILDING STRUCTURE SHALL BE PERFORMED IN A CODE APPROVED METHOD AND NOT THREATEN THE INTEGRITY OF THE BUILDING STRUCTURE.
- SUPPORT ALL DUCTWORK AND PIPING IN ACCORDANCE WITH THE APPLICABLE MECHANICAL CODE. ANY SUSPENDED MATERIALS SHALL BE DIRECTLY SUPPORTED BY THE BUILDING STRUCTURE. DO NOT ATTACH ANYTHING TO THE ROOF DECK.
- PENETRATIONS OF ALL EXTERIOR WALLS, FLOORS AND CEILINGS SHALL BE SEALED IN AN AIR TIGHT MANNER AND IN ACCORDANCE WITH THE APPLICABLE ENERGY CONSERVATION CODE.
- THE MECHANICAL CONTRACTOR SHALL BE RESPONSIBLE FOR PROTECTING ALL MECHANICAL EQUIPMENT FROM FOREIGN MATERIAL DURING CONSTRUCTION (PAINT, SPACKLE, ETC.). UPON COMPLETION OF WORK, THE MECHANICAL CONTRACTOR SHALL CLEAN, WASH, ETC. ALL ITEMS AND EQUIPMENT WITHIN THE SCOPE OF WORK AND LEAVE ALL ITEMS BRIGHT AND CLEAN.

SPECIAL NOTICE TO CONTRACTORS

- ALL CONTRACTORS (GENERAL CONTRACTOR AND SUB-CONTRACTORS) BIDDING THIS PROJECT ARE REQUIRED TO VISIT THE JOB SITE AND VERIFY THE EXISTING CONDITIONS PRIOR TO SUBMITTING THEIR BID. CONTRACTORS ARE TO CAREFULLY REVIEW ALL CONSTRUCTION DOCUMENTS AND NOTE ANY DISCREPANCIES BETWEEN THE CONSTRUCTION DOCUMENTS AND THE CONDITIONS OBSERVED AT THE JOB SITE PRIOR TO SUBMISSION OF ANY BID. THE BUILDING OWNER REPRESENTATIVE MAY BE CONTACTED FOR ACCESS TO THE JOB SITE.
- PRIOR TO CONSTRUCTION CONTRACTORS ARE RESPONSIBLE FOR VERIFYING THE LOCATION AND CONDITION OF THE FOLLOWING:
 - ALL POINTS OF CONNECTION TO BUILDING UTILITIES AND/OR SYSTEMS INCLUDING, BUT NOT LIMITED TO GAS, WATER, SEWER, VENT, ELECTRICAL, MECHANICAL SYSTEMS, DUCTWORK, EXHAUST/OUTSIDE AIR, SECURITY, FIRE/LIFE SAFETY, DATA, AND PHONE.
 - ALL REQUIRED CONNECTIONS TO THE BUILDING STRUCTURE
 - ALL REQUIRED BUILDING PENETRATIONS. IT IS RECOMMENDED THAT THE CONTRACTOR X-RAY ALL PENETRATIONS THRU CONCRETE AND MASONRY.
- ANY DISCREPANCIES BETWEEN THE CONSTRUCTION DOCUMENTS AND THE CONDITIONS OBSERVED SHALL BE BROUGHT TO THE ATTENTION, IN WRITING, TO THE ARCHITECT AND/OR ENGINEER PRIOR TO PROCEEDING WITH CONSTRUCTION.
- SEE ARCHITECTURAL PLANS FOR CONTACT INFORMATION.

MECHANICAL ABBREVIATIONS

AFF	ABOVE FINISHED FLOOR	KW	KILOWATT
AHJ	AUTHORITY HAVING JURISDICTION	LAT	LEAVING AIR TEMPERATURE
A	AMPERE (AMP, AMPS)	LB	POUNDS
ANSI	AMERICAN NATIONAL STANDARDS INSTITUTE	LRA	LOCKED ROTOR AMPS
		MAX.	MAXIMUM
APPROX.	APPROXIMATELY	MBH	ONE THOUSAND BTU/HR
ASHRAE	AMERICAN SOCIETY OF HEATING, REFRIGERATING, AND AIR CONDITIONING ENGINEERS	M.C.	MECHANICAL CONTRACTOR
		MCA	MINIMUM CIRCUIT AMPACITY
BTU	BRITISH THERMAL UNIT	MIN.	MINIMUM
BTU/HR	BTU PER HOUR	MOCP	MAXIMUM OVERCURRENT PROTECTION
CFM	CUBIC FEET PER MINUTE	N/A	NOT APPLICABLE
DB	DRY BULB TEMPERATURE (°F)	NC	NOISE CRITERIA
DEG	DEGREE	NTS	NOT TO SCALE
DEMO	DEMOLISH OR DEMOLITION	OA	OUTDOOR AIR
DIA	DIAMETER	P.C.	PLUMBING CONTRACTOR
EAT	ENTERING AIR TEMPERATURE	RA	RETURN AIR
E.C.	ELECTRICAL CONTRACTOR	RH	RELATIVE HUMIDITY
ESP	EXTERNAL STATIC PRESSURE	RLA	RUNNING LOAD AMPS
EXIST.	EXISTING	RPM	REVOLUTIONS PER MINUTE
*F	DEGREES FAHRENHEIT	RTU	ROOFTOP UNIT
FLA	FULL LOAD AMPS	SA	SUPPLY AIR
F.P.C.	FIRE PROTECTION CONTRACTOR	SEER	SEASONAL ENERGY EFFICIENCY RATIO
FPM	FEET PER MINUTE	SF	SQUARE FOOT/FEET
FT	FOOT OR FEET	SQ. FT.	SQUARE FOOT/FEET
G.C.	GENERAL CONTRACTOR	TYP.	TYPICAL
HP	HORSEPOWER OR HEAT PUMP	V	VOLTAGE
HR	HOUR	VAV	VARIABLE AIR VOLUME
HSPF	HEAT PUMP SEASONAL PERFORMANCE FACTOR	W	WATT
IN.	INCHES	WB	WET BULB TEMPERATURE (°F)
IN. W.G.	INCHES WATER GAUGE		

MECHANICAL BUILDING CODE SUMMARY

MECHANICAL SUMMARY

MECHANICAL SYSTEMS, SERVICE SYSTEMS AND EQUIPMENT

THERMAL ZONE 4A
 WINTER DRY BULB: 21.6°F
 SUMMER DRY BULB: 84.2°F
 SUMMER WET BULB: 74.7°F

INTERIOR DESIGN CONDITIONS
 WINTER DRY BULB: 69°F
 SUMMER DRY BULB: 75°F
 RELATIVE HUMIDITY: 50%

HEATING AND COOLING LOADS
 BUILDING HEATING LOAD: SEE SCHEDULES
 BUILDING COOLING LOAD: SEE SCHEDULES

MECHANICAL SPACING CONDITIONING SYSTEM UNITARY

DESCRIPTION OF UNIT: SEE SCHEDULES
 HEATING EFFICIENCY: SEE SCHEDULES
 COOLING EFFICIENCY: SEE SCHEDULES
 SIZE CATEGORY OF UNIT: SEE SCHEDULES

EQUIPMENT EFFICIENCIES
 COOLING EFFICIENCY: SEE SCHEDULES
 HEATING EFFICIENCY: SEE SCHEDULES

MECHANICAL DRAWING SYMBOLS

	DOUBLE LINE RECTANGULAR DUCT (DIMENSIONS IN INCHES)
	DOUBLE LINE ROUND DUCT
	SUPPLY AIR DUCT ELBOW DOWN WITH TURNING VANES, INSTALLED PER SMACNA STANDARDS
	RETURN AIR DUCT ELBOW DOWN WITH TURNING VANES, INSTALLED PER SMACNA STANDARDS
	EXHAUST AIR DUCT ELBOW DOWN WITH TURNING VANES, INSTALLED PER SMACNA STANDARDS
	SUPPLY AIR DUCT ELBOW UP WITH TURNING VANES, INSTALLED PER SMACNA STANDARDS
	RETURN AIR DUCT ELBOW UP WITH TURNING VANES, INSTALLED PER SMACNA STANDARDS
	EXHAUST AIR DUCT ELBOW UP WITH TURNING VANES, INSTALLED PER SMACNA STANDARDS
	DUCT ELBOW WITH TURNING VANES, INSTALLED PER SMACNA STANDARDS
	CEILING SUPPLY DIFFUSER, DESIGNATION AS NOTED
	CEILING RETURN GRILLE, DESIGNATION AS NOTED
	MANUAL VOLUME DAMPER WITH QUADRANT EXTENSION FOR OPERATION WITH EXTERNALLY INSULATED DUCTWORK
	AIR DISTRIBUTION TAG "X" REPRESENTS TAG "#/#" REPRESENTS CFM
	RETURN/EXHAUST AIRFLOW DIRECTION
	7-DAY PROGRAMMABLE THERMOSTAT WITH OCCUPANCY CONTROL. MOUNT AT 48" AFF TO CONFORM TO ADA AND NC ACCESSIBILITY REQUIREMENTS.
	AUDIO/VISUAL CONDENSATE ALARM WITH REMOTE TEST SWITCH
	REMOTE WIRELESS ZONE TEMPERATURE SENSOR
	POINT OF CONNECTION CONNECT TO EXISTING OR DISCONNECT FROM EXISTING
	KEY NOTE TAG

TABLE 305.4
PIPING SUPPORT SPACINGa

PIPING MATERIAL	MAXIMUM HORIZONTAL SPACING (feet)	MAXIMUM VERTICAL SPACING (feet)
ABS pipe	4	10c
Aluminum pipe and tubing	10	15
Brass pipe	10	10
Brass tubing, 1 1/4-inch diameter and smaller	6	10
Brass tubing, 1 1/2-inch diameter and larger	10	10
Cast-iron pipe	5	15
Copper or copper-alloy pipe	12	10
Copper or copper-alloy tubing, 1 1/4-inch diameter and smaller	6	10
Copper or copper-alloy tubing, 1 1/2-inch diameter and larger	10	10
CPVC pipe or tubing, 1 inch and smaller	3	10c
CPVC pipe or tubing, 1 1/4-inch and larger	4	10c
Lead pipe	Continuous	4
PB pipe or tubing	2 1/2 (32 inches)	4
PE-RT 1 inch and smaller	2 1/2 (32 inches)	10c
PE-RT 1 1/2 and larger	4	10c
PEX tubing	22 1/2 (32 inches)	10c
Polypropylene (PP) pipe or tubing, 1 inch or smaller	22 1/2 (32 inches)	10c
Polypropylene (PP) pipe or tubing, 1 1/4 inches or larger	4	10c
PVC pipe	4	10c
Steel tubing	8	10
Steel pipe	12	15

For Sl: 1 inch = 25.4 mm, 1 foot = 304.8 mm.
 a. See Section 301.18.
 b. The maximum horizontal spacing of cast-iron pipe hangers shall be increased to 10 feet where 10-foot lengths of pipe are installed.
 c. Mid-story guide.

DIFFUSER SCHEDULE

CFM	NECK SIZE
0 - 100	6"
101 - 200	8"
201 - 350	10"
351 - 650	12"
651 - 1000	14"

FOR ANY RUN-OUT OVER 20' IN LENGTH, USE NEXT SIZE UP ON THIS SCHEDULE. DETERMINE LENGTH IN FIELD.

PROJECT SPECIFIC NOTES:

- ALL EXPOSED DUCT SHALL BE INTERNALLY INSULATED DOUBLE WALL SPIRAL DUCT WORK WITH PAINT GRIP FINISH. INTERNAL INSULATION SHALL BE PROVIDED WITH PERFORATED INNER SHEET METAL WALL.
- ALL CONCEALED DUCT WORK SHALL BE EXTERNALLY INSULATED.
- THERE SHALL BE NO COOKING OF FOODS ON THE PREMISES.
- INTAKE TERMINATIONS SHALL BE LOCATED A MINIMUM OF 10 FEET FROM ALL EXHAUST AND VENT TERMINATIONS IN COMPLIANCE WITH THE NORTH CAROLINA MECHANICAL CODE.
- EXHAUST TERMINATIONS SHALL BE A MINIMUM OF 10 FEET FROM ALL INTAKE OPENINGS AND OPERABLE OPENINGS INTO THE BUILDING IN COMPLIANCE WITH THE NORTH CAROLINA MECHANICAL CODE.
- DRAWING IS DIAGRAMMATIC IN NATURE AND NOT INTENDED TO INDICATED FINAL INSTALLED LOCATIONS OF EQUIPMENT OR DUCTWORK. DRAWINGS DEMONSTRATE DESIGN INTENT ONLY. CONTRACTORS ARE RESPONSIBLE FOR FINAL COORDINATION AND THE PRODUCTION OF ACCURATE, DIMENSIONED SHOP DRAWINGS AS REQUIRED TO PROVIDE A COMPLETE INSTALLATION. THERE SHALL BE NO ALLOWANCES GIVEN FOR THE LACK OF CONTRACTOR COORDINATION. MAINTAIN ALL CODE AND MANUFACTURER REQUIRED CLEARANCES TO ALL EQUIPMENT AND DEVICES.
- ALTERNATE DUCT SIZES/SHAPE ARE ALLOWED AND ARE NOT REQUIRED TO BE RESUBMITTED TO THE PERMIT DEPARTMENT. MAINTAIN DUCT PRESSURE DROP AND VELOCITY. SEE SPECIFICATIONS FOR ADDITIONAL DETAILS. ALL CHANGES SHALL BE CAPTURED IN THE CONTRACTORS SHOP DRAWINGS.

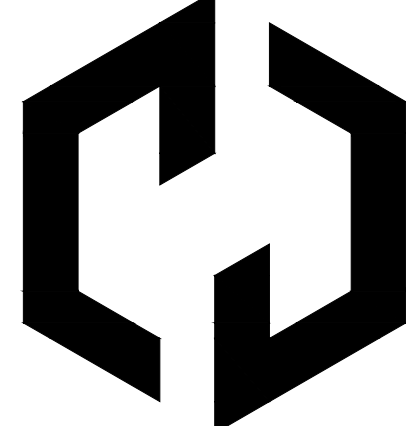

Ossa STUDIO

4539 HEDGEMORE DRIVE, SUITE 101
 CHARLOTTE NC 28209
 704.890.2563
 WWW.OSSASTUDIO.COM

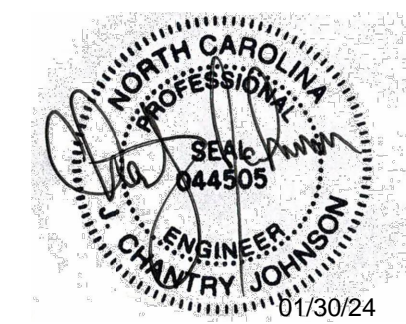

PROJECT TEAM

General Contractor
 ECCLESIA CONSTRUCTION
 www.ecclesiainc.com
 803.327.5670

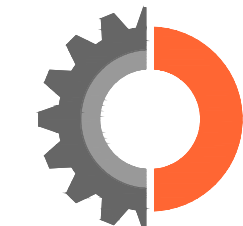

ENGITECTURE
CONSULTING ENGINEERS

ENGITECTURE, PLLC
 NC License No. P-1625

4539 Hedgemore Drive, Suite 102
 Charlotte, NC 28209
 704-287-2193
 PROJ# 23253

△ Date Description

01/30/2024 ISSUE FOR CONSTRUCTION

Project Name



community church
 making church come alive

658 GRAHAM ROAD
 SANFORD NC 27311

Client

3D COMMUNITY CHURCH

Project Number

23024.00

Description

NOTES & ABBREVIATIONS - HVAC

Scale

NA

M00.01

GENERAL NOTES AND SPECIFICATIONS
(ABRIDGED VERSION, SEE FULL DIVISION 23 STANDARD SPECIFICATIONS,
AVAILABLE UPON REQUEST)

- THESE DRAWINGS ARE SCHEMATIC IN NATURE AND ARE NOT INTENDED TO SHOW ALL POSSIBLE CONDITIONS. IT IS INTENDED THAT A COMPLETE TENANT MECHANICAL SYSTEM BE PROVIDED WITH ALL NECESSARY EQUIPMENT, ACCESSORIES, OPTIONS AND CONTROLS. COMPLETELY COORDINATED WITH ALL DISCIPLINES. ALL ITEMS AND LABOR REQUIRED FOR A COMPLETE TENANT MECHANICAL SYSTEM SHALL BE ACCORDANCE WITH ALL APPLICABLE CODES, STANDARDS AND THE BASE BUILDING CONTRACT DOCUMENTS SHALL BE FURNISHED WITHOUT INCURRING ADDITIONS TO THE CONTRACT.
- REFER TO THE ARCHITECTURAL DRAWINGS FOR EXACT PARTITION LAYOUTS, REFLECTED CEILING PLANS, DIMENSIONS, ETC.
- ALL MATERIALS AND EQUIPMENT SHALL BE PROPERLY AND EFFECTIVELY PROTECTED BY THE CONTRACTOR DURING THE EXECUTION OF THE WORK.
- EQUIPMENT IDENTIFIED ON DRAWINGS IN SOME INSTANCES ARE LOCATED FOR DRAWING CLARITY. COORDINATE EXACT LOCATION OF EQUIPMENT WITH STRUCTURE, OTHER EQUIPMENT, AND OTHER TRADES TO ALLOW CLEARANCE FOR EQUIPMENT ACCESS PER MANUFACTURERS REQUIREMENTS.
- ALL WORK SHALL BE CONSTRUCTED IN ACCORDANCE WITH THE NORTH CAROLINA MECHANICAL, FUEL GAS AND PLUMBING CODE.
- CONTRACTOR SHALL COORDINATE LOCATIONS AND SIZES OF ALL PENETRATIONS THROUGH WALLS AND CEILING WITH OTHER TRADES INVOLVED.
- ALL SCHEDULED EQUIPMENT SIZES ARE NOMINAL. OPERATING SPEEDS AND POWER REQUIREMENTS ARE MAXIMUM VALUES. AIR VELOCITIES AND PRESSURE DROPS THROUGH SYSTEM COMPONENTS SHALL BE WITHIN 45% OF THOSE INDICATED.
- TEST AND BALANCE ALL DIFFUSERS, BOXES, FANS, PUMPS, ETC. TO THE AIRFLOWS AND CONDITIONS INDICATED. ALL EXISTING DIFFUSERS, BOXES, FANS, ETC. WHICH ARE NOT NOTED OTHERWISE SHALL BE BALANCED TO THEIR PRIOR DESIGN AIRFLOWS. REFERENCE THE EXISTING RECORD DRAWING AVAILABLE FROM THE OWNER. TESTING AND BALANCING OF HVAC SYSTEM SHALL BE PERFORMED IN ACCORDANCE WITH THE STANDARDS OF AABC AND SHALL BE PERFORMED UNDER THE DIRECT SUPERVISION OF AN AABC CERTIFIED TEST AND BALANCE ENGINEER. SUBMIT 4 COPIES OF THE REPORT TO THE OWNER. NEBB AGENCIES ARE NOT ACCEPTABLE AND ARE CAUSE FOR REJECTION.
- ALL FLOOR PENETRATIONS WITHIN THE BUILDING SHALL BE CORE DRILLED. PRIOR TO CORE DRILLING FLOOR, CONTRACTOR SHALL VERIFY EXACT LOCATION OF STRUCTURAL MEMBERS, DUCTWORK, PIPING, EQUIPMENT, ETC., IN CEILING SPACE BELOW. (WHERE CONDUITS MAY EXIST WITHIN THE SLAB THE CONTRACTOR SHALL USE X-RAY TECHNIQUES).
- COORDINATE EXACT LOCATION OF FIRE AND SMOKE RATED WALL TYPES WITH ARCHITECTURAL PLANS.
- PROVIDE ALL SLEEVES, SAW CUTTING, CORE-DRILLING AND FIRE STOPPING ASSOCIATED WITH DIVISION 15 (EXCLUDING FIRE PROTECTION WORK, SEAL, FIRE SMOKE, AS REQUIRED) ALL PENETRATIONS (BOTH NEW AND DEMOLITION WORK) CAUSED BY PLUMBING/MECHANICAL WORK. SEAL ALL FLOOR AND DECK PENETRATIONS CAUSED BY MECHANICAL/PLUMBING DEMOLITION WITH CONCRETE. ALL PENETRATIONS MUST BE FIRE STOPPED IN THE SAME DAY THEY ARE CREATED.
- IT SHALL BE THE RESPONSIBILITY OF THE MECHANICAL CONTRACTOR TO ENSURE THAT AT THE BEGINNING OF EACH NIGHT OUTAGE, THAT AIR, PLUMBING, MEDICAL GASES AND ALL OTHER SERVICES DISRUPTED BY THE SCOPE OF WORK ARE SUPPLIED TO ALL AREAS OF THE FACILITY REMAINING IN OPERATION. THIS INCLUDES FINISHING AND INSTALLING ANY TEMPORARY MATERIALS NECESSARY TO ACCOMPLISH THIS.
- RECEIVE, UNLOAD, HOIST TO FINAL LOCATION, SET INTO PLACE, CONNECT, TEST AND BALANCE ALL NEW PREPURCHASE EQUIPMENT INCLUDING WARRANTY FOR INSTALLATION ONLY UPON DELIVERY TO SITE. COORDINATE DELIVERY WITH THE RESPECTIVE EQUIPMENT MANUFACTURER.
- FURNISH AND INSTALL ALL ROOF MOUNTED SUPPORT STRUCTURES. INCLUDE ALL SUPPORTS, CURBS, ANGLES, CLIPS, ALL THREAD, BOLTS, AND OTHER CONNECTIONS TO SUPPORT AND MOUNT NEW WORK. COORDINATE WITH ROOFING
- ALL WELDS SHALL BE PERFORMED BY A CERTIFIED WELDER. A CERTIFICATE FOR THE WELDER PERFORMING WORK ON THIS PROJECT SHALL BE SUBMITTED DURING THE SUBMITTAL PROCESS FOR APPROVAL BY THE OWNER AND ENGINEER. PHOTO IDENTIFICATION OF THE CERTIFIED WELDER SHALL BE PRESENTED TO THE PROJECT SUPERINTENDENT PRIOR TO WORKING ON SITE.
- ALL INDIVIDUAL DUCTWORK/PIPPING SECTIONS SHALL BE WRAPPED PRIOR TO DELIVERY TO JOBSITE TO PREVENT CONTAMINATION. WRAPPING SHALL BE MAINTAINED UNTIL DUCTWORK IS HUNG IN PLACE.
- AT THE END OF EACH SHIFT, THE CONTRACTOR SHALL SEAL THE OPEN ENDS OF DUCTWORK/PIPPING TO PREVENT DUST INFILTRATION.
- FOLLOW ALL REQUIREMENTS OF THE MANUFACTURERS' INSTALLATION, OPERATION, AND STARTUP INSTRUCTIONS AND THE SPECIFICATIONS LISTED BELOW. THE MATERIALS AND WORKMANSHIP SHALL MEET AND/OR EXCEED THESE SPECIFICATIONS. IN THE EVENT THERE IS A CONFLICT BETWEEN THESE SPECIFICATION, THE MANUFACTURERS' REQUIREMENTS, AND/OR LOCAL AUTHORITY REQUIREMENTS, THE MOST STRINGENT SHALL APPLY.
- ANY PENETRATION OF A FIRE AND/OR SMOKE RATED ASSEMBLY SHALL BE PROTECTED IN A U.L. APPROVED MANNER.
- CONTRACTOR IS RESPONSIBLE FOR INSTALLING AND/OR MODIFYING ALL CONTROLS AND SAFETY DEVICES REQUIRED BY THE LOCAL AUTHORITY. CONTRACTOR IS TO FIELD VERIFY AND INCLUDE ANY CONTROLS AND SAFETY DEVICE WORK IN PROPOSAL.
- ALL WORK SHALL BE PERFORMED IN A NEAT AND WORKMAN LIKE MANNER.
- PRESSURE TEST ALL PIPING, DUCT WORK AND EQUIPMENT PRIOR TO FINAL CONNECTION TO EXISTING SYSTEM. PROVIDE OWNER WITNESS DOCUMENTATION.
- CONTRACTOR SHALL VERIFY THE CLEANLINESS OF HYDRONIC SYSTEMS PRIOR TO MAKING CONNECTION TO NEW EQUIPMENT. CONTRACTOR SHALL NOTIFY PROPERTY AND PROJECT MANAGER IF HIGH CONCENTRATIONS OF SOLIDS ARE DETECTED.
- DEBRIS FROM DEMOLITIONS AND CONSTRUCTION SHALL BE REMOVED FROM THE PROPERTY.
- DEBRIS SHALL BE DISPOSED OF PER LOCAL, STATE, AND FEDERAL REGULATIONS.
- WORK SITE SHALL BE KEPT CLEAN AT ALL TIMES. WORK SITE SHALL BE BROOM CLEANED AT THE COMPLETION OF EACH WORK DAY. ALL DEBRIS AND MATERIAL SHALL BE REMOVED FROM JOB SITE EACH DAY UNLESS THE PROPERTY DESIGNATES A DEBRIS STORAGE AREA.
- CONTRACTOR SHALL NOT UTILIZED THE PROPERTY'S DUMPSTER UNLESS APPROVAL IS GIVEN BY THE PROPERTY.
- FRESH AIR INTAKES AND EXHAUST/FLUE/VENT TERMINATIONS SHALL BE SEPARATED A MINIMUM OF 10 FT AND INSTALLED IN ACCORDANCE WITH THE LOCAL MECHANICAL CODE.

DUCT:

- ALL RETURN AIR AND TRANSFER AIR DUCT WORK SHALL BE INTERNAL LINED FOR SOUND ATTENUATION. NO DUCT LINER SHALL BE INSTALLED IN DUCT WORK SERVING LABS, CLEAN ROOMS, PHARMACIES, OR OPERATING ROOMS.
- ALL NEW DUCTWORK: THE FABRICATION AND INSTALLATION OF ALL NEW DUCTWORK TOGETHER WITH RELATED EQUIPMENT, SHALL COMPLY WITH "SMACNA" DUCT CONSTRUCTION STANDARDS, NFPA 90A & 90B, LATEST ADDITION OF ASHRAE GUIDE & DATA BOOK, AS DETAILED ON THE DRAWINGS & PER LOCAL CODES.
- THE DUCTWORK CONTRACTOR SHALL INSTALL AND SECURE ALL NEW DUCTWORK TO ROOF STRUCTURE IN ATTIC SPACE ABOVE ARCHITECTURAL CEILING.
- THE DUCTWORK CONTRACTOR SHALL VERIFY & FIELD MEASURE PRIOR TO FABRICATION OF NEW DUCTWORK.
- ALL NEW DUCTWORK SHALL BE GALVANIZED SHEETMETAL, UNLESS NOTED OTHERWISE. MIN. R-8 INSULATION FOR SUPPLY DUCT AND R-4.2 FOR RETURN AND EXHAUST DUCT.
- FLEXIBLE DUCT SHALL BE UL LISTED AS CLASS 1 CONNECTOR, STANDARD 181 AND SHALL COMPLY WITH NFPA 90A. THE FLEXIBLE DUCT SHALL HAVE AN EXTERIOR JACKET OF FIBERGLASS INSULATION ENCLOSED IN A VINYL VAPOR BARRIER AND WITH AN INNER LINER TOTALLY ENVELOPING THE HELICAL COIL. MINIMUM R-8 INSULATION VALUE. ACCEPTABLE MANUFACTURERS: ATCO - "UPC #078" OR APPROVED EQUAL.
- PROVIDE FLEXIBLE DUCT OF THE SAME SIZE INDICATED ON THE DRAWINGS. THE CONTRACTOR SHALL PROVIDE ALL NECESSARY TRANSITIONS AS REQUIRED FOR A COMPLETE CONNECTION.
- PENETRATION OF NEW DUCTWORK BY PIPES, CONDUITS, ELECTRICAL FIXTURES, OR STRUCTURAL MEMBERS IS NOT ACCEPTABLE.
- COORDINATE EXACT LOCATION OF WALL MOUNTED THERMOSTAT SHOWN ON DRAWINGS WITH EQUIPMENT LAYOUT AND ARCHITECT OWNER.
- ALL DUCT SIZES ARE CLEAR INSIDE DIMENSIONS.
- THE DUCTWORK CONTRACTOR SHALL COORDINATE HIS WORK WITH BOTH THE ELECTRICAL AND CEILING CONTRACTOR THROUGHOUT THE ENTIRE PROJECT.
- ALL DIFFUSERS, REGISTERS, GRILLES, INTAKES SHALL BE BALANCED TO AIRFLOW SHOWN ON MECHANICAL PLANS.

- ALL CONTROL WIRING AND TUBING INSTALLED ABOVE THE CEILING SHALL BE LOCATED AS HIGH ABOVE THE CEILING AS POSSIBLE AND SHALL FOLLOW THE DESIGNATED GENERAL ROUTING OF THE DUCTWORK. DO NOT HANG WIRING OR TUBING FROM DUCTWORK; RATHER, SUSPEND FROM THE STRUCTURE.
- THERMOSTATS SHALL BE LOCATED IN EACH ZONE AS SHOWN. THE EXACT LOCATION ON THE WALL INDICATED SHALL BE AS DIRECTED BY THE ARCHITECT. NEW THERMOSTATS SHALL BE SELECTED TO MATCH EXISTING BASE BUILDING THERMOSTATS AND SHALL BE COMPATIBLE WITH EQUIPMENT SERVED.
- ALL DUCTWORK SHALL BE GALVANIZED SHEET METAL CONSTRUCTED IN ACCORDANCE WITH THE LATEST SMACNA STANDARDS.
- PRESSURE CLASS SHALL BE 150% OF FAN EXTERNAL STATIC PRESSURE AT DEAD HEAD.
- SIZE DUCTWORK PER CURRENT ASHRAE FUNDAMENTALS.
- RECOMMENDATION
 - LOW PRESSURE SUPPLY DUCT WORK
 - NTE - 0.1 INCH/100FT & 1400 FPM.
 - MEDIUM PRESSURE SUPPLY DUCT WORK
 - NTE - 0.25 INCH/100FT & 2500 FPM.
 - TOILET EXHAUST AND RETURN DUCT WORK
 - NTE - 0.1 INCH/10FT & 1200 FPM.
- PROVIDE TURNING VANES AT ALL RECTANGULAR ELBOWS. TURNING VANES ARE NOT ALLOWED IN MEDIUM PRESSURE DUCT WORK UNLESS SPECIFICALLY APPROVED.
- ALL JOINTS SHALL BE SEALED WITH DUCTMATE 35 OR SIMILAR SYSTEM IN A CLEAN AND PROFESSIONAL MANNER.
- ALL DUCTWORK CONVEYING SUPPLY AIR, RETURN AIR LOCATED ON UPPER FLOOR OR OUTDOORS, AND OUTSIDE AIR LOCATED INDOORS SHALL BE INSULATED.
- INSULATION AND ADHESIVE SHALL MEET 2550 FLAME SPREAD AND SMOKE DEVELOPMENT. COMPLIANCE WITH NFPA 90A & 90B.
- INTERNAL LINING (INDOORS): CERTAINTED TOUGHGARD 1R" DUCT LINER. TYPE 150, 2.0 INCH THICKNESS. R-8 MINIMUM OR AS REQUIRED BY LOCAL CODE.
- INTERNAL LINING (OUTDOOR): CERTAINTED TOUGHGARD RIGID LINER BOARD. 2.0 INCH THICKNESS. R-8.7 MINIMUM OR AS REQUIRED BY LOCAL CODE.
- EXTERNAL WRAP (INDOORS): CERTAINTED SOFTTOUCH DUCTWRAP, TYPE 75, 2.25 INCH THICKNESS. R-8 MINIMUM OR AS REQUIRED BY CODE.
- ALL DUCTWORK SHALL BE PROPERLY SUPPORTED. WOOD PRODUCTS ARE NOT PERMITTED FOR SUPPORTS.
- DUCTWORK INSTALLED ON ROOF SHALL BE SUPPORTED BY ROOF RAILS ATTACHED TO THE BUILDING ROOFING SYSTEM IN LOCATION WHERE WIND COULD DAMAGE THE DUCTWORK. DO NOT SCREW INTO DUCTWORK. SUPPORT BETWEEN 2 PIECES OF UNI-STRUT.
- IT IS NOT ACCEPTABLE TO SUPPORT FROM EXISTING PIPE OR DUCTWORK.

PIPE:

- PIPE SUPPORT ATTACHMENT TO BRIDGING OR METAL ROOF DECK IS STRICTLY PROHIBITED.
- GAS PIPING IN THE BUILDING SHALL BE THREADED SCHEDULE 40 BLACK STEEL UNDER 4" SYSTEMS ABOVE 4" SHALL BE WELDED IN COMPLIANCE WITH THE SC FUEL GAS CODE. PROVIDE HANGERS IN COMPLIANCE WITH THE SC MECHANICAL, FUEL GAS AND PLUMBING CODES.
- GAS PIPING SHALL BE SCHEDULE 40 BLACK STEEL COMPLYING WITH ANSI B36.10.
- ABOVEGROUND DOMESTIC WATER SYSTEM PIPING 2" IN SIZE AND SMALLER SHALL BE TYPE L HARD DRAWN COPPER TUBING WITH WROUGHT COPPER FITTINGS AND SOLDERED JOINTS.
- PROVIDE PIPE HANGERS FOR IN COMPLIANCE WITH THE NORTH CAROLINA PLUMBING CODE.
- ALL HOT AND COLD WATER PIPING SHALL BE INSULATED WITH 1" THICK PREFORMED FIBERGLASS PIPE INSULATION WITH ALL-SERVICE JACKET. ALL LONGITUDINAL JOINTS, TEARS, ETC., SEALED WITH A MATCHING WHITE VAPOR BARRIER TAPE. ELBOWS SHALL BE MITERED OR MAY BE ZESTON COVERS FILLED WITH EQUIVALENT FIBERGLASS INSULATION.
- ANY ITEM OR EQUIPMENT THAT IS REMOVED OR RELOCATED TO FACILITATE THE DEMOLITION AND/OR NEW WORK SHALL BE CLEANED AND REINSTALLED BACK TO ITS ORIGINAL OR NEW LOCATION. PATCH ALL OPENINGS IN FLOOR, CEILINGS, AND WALLS MADE IN ADJACENT AREAS THAT ARE NOT BEING DEMOLISHED.
- REMOVE OR REUSE ALL HANGERS, SUPPORTS, AND ACCESSORIES ASSOCIATED WITH ITEMS OR EQUIPMENT BEING DEMOLISHED.
- EXISTING SERVICES ARE BASED ON ORIGINAL DRAWINGS AND LIMITED FIELD WORK. CONTRACTOR SHALL VERIFY EXISTING SERVICES PRIOR TO TIE-IN.
- PROVIDE PIPE UNIONS AT ALL AUTOMATIC CONTROL VALVES AND VARIABLE AIR VOLUME TERMINAL UNIT REHEAT COIL CONNECTIONS. REFER TO SPECIFICATION SECTION 15050 FOR ADDITIONAL REQUIREMENTS.
- ALL SANITARY PIPING SHALL BE INSTALLED AT A MINIMUM SLOPE OF 1/8" PER FOOT.
- STORM WATER PIPING SHALL BE INSTALLED AT A MINIMUM SLOPE OF 1/8" PER FOOT (OR AS INDICATED ON THE FLOOR PLANS).
- THE MEDICAL GAS AND VACUUM SYSTEMS SHALL BE INSTALLED IN ACCORDANCE WITH NFPA 99 AND UPON COMPLETION SHALL BE TESTED AND CERTIFIED BY AN INDEPENDENT TESTING AGENCY.
- ALL HVAC WATER SUPPLY AND RETURN PIPING SHALL BE SCHEDULE 40 STEEL.
- ALL HVAC WATER SUPPLY AND RETURN PIPING SHALL BE INSULATED WITH 1-1/2" THICK FIBERGLASS PERFORMED PIPE INSULATION WITH A WHITE ALL-SERVICE JACKET/VAPOR BARRIER.
- BALANCING VALVES SHALL HAVE A CAST IRON BODY, BRONZE TRIM AND BRONZE DISC. VALVE SHALL BE SUITABLE FOR 125 PSIG WORKING PRESSURE AND PROVIDE POSITIVE SHUT-OFF. EACH BALANCING VALVE SHALL BE EQUIPPED WITH TWO GAUGE TAPS WITH CHECK VALVES AND DRIP CAPS. PROVIDE PREFORMED INSULATION TO ENCASE VALVE ASSEMBLY. BALANCING VALVES SHALL BE AUTO FLOW TYPE URT OR GRISWOLD 3600. AFTER THE TEST AND BALANCE IS COMPLETE, PROVIDE TO THE OWNER A DIFFERENTIAL PRESSURE GAUGE TO MATCH THE BALANCING VALVES.
- ALL PIPING AND SPECIALTIES MATERIAL SHALL BE SUITABLE FOR SYSTEM TYPE, APPLICATION, AND CONFORM TO LOCAL CODE AND REGULATIONS.
- INCLUDE ALL LABOR AND MATERIALS TO PROVIDE A COMPLETE FUNCTIONAL SYSTEM, INCLUDING: ISOLATION AND BALANCING VALVES, FITTINGS, UNIONS, ADAPTERS, REDUCERS, HANGERS, THREADED RODS, ANCHORS, TEMPERATURE AND PRESSURE GAUGES, ETC. SOME SPECIALTIES MAY BE PROVIDED BY OWNER OR CONTROLS CONTRACTOR.
- PIPPING SHALL BE PITCHED DOWN IN THE DIRECTION OF FLOW WITH MANUAL AIR VENTS AT ALL HIGH POINTS AND DRAINS AT ALL LOW POINTS. VENTS AND DRAINS SHALL CONTAIN 3/4" BALL VALVE WITH CAP AND HOSE CONNECTION. PROVIDE AUTOMATIC AIR VENTS AT HIGH POINTS IN INACCESSIBLE AREAS AND PIPE TO NEAREST FLOOR DRAIN.
- INSTALL DIELECTRIC UNION AT CONNECTION OF DISSIMILAR METALS.
- INSTALL HEAT TRACE OF PIPING OUTDOORS AND IN AREAS AT RISK OF FREEZE TEMPERATURES.
- DOMESTIC WATER PIPING:
 - TYPE L HARD DRAWN SEAMLESS COPPER AND CAST COPPER FITTINGS.
 - JOINTS UP TO 1 INCH TINSILVER SOLDER
 - JOINTS OVER 1 INCH SILVER/PHOSPHORUS SOLDER
 - UPON APPROVAL PRO-PROCESS JOINTS MAY BE USED PIPING 2 INCH DIAMETER OR LESS.
 - STERILIZE SYSTEM IN ACCORDANCE WITH AMERICAN WATER WORK ASSOCIATION AND LOCAL HEALTH DEPARTMENT REGULATIONS.
- HYDRONIC WATER PIPING:
 - SCHEDULE 40 BLACK STEEL
 - VICTUALJG AND/OR WELDED CONNECTIONS.
 - NPT CONNECTION FOR 2 INCH DIAMETER OR LESS IS ALLOWED.
- VALVES:
 - MANUFACTURER: APOLLO
 - MATERIAL AND VALVE TYPE
 - DOMESTIC, BRONZE, BRASS, OR STAINLESS STEEL

- HYDRONIC/GAS: IN ADDITION TO THE ABOVE, STEEL.
- 3/4 INCH TO 4 INCH DIAMETER: FULL PORT BALL VALVE
- OVER 4 INCH DIAMETER: BUTTERFLY VALVE
- STRAINERS:
 - ALL EQUIPMENT CONTAINING HYDRONIC COILS OR HEAT EXCHANGERS SHALL BE PROVIDE WITH A STRAINER IN THE SUPPLY WATER PIPING.
 - Y-STRAINER: STAINLESS INTERNAL MESH AND BLOW DOWN VALVE AND CAP. SELECT PROPER MESH SIZE AS RECOMMENDED BY THE EQUIPMENT MANUFACTURE AND APPLICATION.
- CHECK VALVES:
 - CHECK SHALL BE INSTALLED AT EQUIPMENT PIPED IN PARALLEL AND CERTAIN PIPING CONFIGURATION SUBJECT TO REVERSE FLOW AND SHORT CYCLING.
- SWING CHECK:
- GAUGES AND SENSORS:
 - PRESSURE GAUGE: ASME B40.1, 4-1/2 INCH DIAMETER DRAWN STEEL CASE, PHOSPHOR BRONZE BOURDON TUBE, ROTARY BRASS MOVEMENT, BRASS SOCKET, WITH FRONT CALIBRATION ADJUSTMENT, BLACK SCALE ON WHITE BACKGROUND, ONE PERCENT MID-SCALE ACCURACY, SCALE CALIBRATED IN "F". GAUGE RANGE SUITABLE FOR SYSTEM PRESSURE.
 - TEMPERATURE GAUGE: ASTM E1, 12 INCH SCALE, STEAM TYPE, ADJUSTABLE ANGLE, RED APPEARING SPIRIT, LEN FRONT TUBE CAST ALUMINUM CASE WITH ENAMEL FINISH AND CLEAR GLASS WINDOW, BRASS STEAM, CAST ALUMINUM ADJUSTABLE JOINT WITH POSITIVE LOCKING DEVICE, 2 PERCENT OF SCALE ACCURACY TO ASTM E77, SCALE CALIBRATED IN "F". GAUGE RANGE SUITABLE FOR SYSTEM TEMPERATURE.

PIPE INSULATION

- PIPPING CONVEYING CHILLED WATER, HYDRONIC HEATING WATER, OR DOMESTIC HOT WATER SHALL BE INSULATED WITH MINERAL FIBER OR FIBERGLASS PREFORMED INSULATION. PRE-FORM FITTINGS FOR VALVES AND FITTINGS.
 - OWENS CORNING OR EQUAL: ASTM C 547, "K" VALUE OF 0.26 AT 75°F, NON COMBUSTIBLE. FLAME SMOKE DEVELOPMENT: ASTM E84 25/50
- INSULATION THICKNESS: (GREATER IF REQUIRED BY CODE)
 - PIPPING DIAMETER UP TO 3/4 INCH: 3/4 INCH
 - PIPPING DIAMETER 1 INCH TO 1-1/2 INCH: 1 INCH
 - PIPPING DIAMETER 2 INCH AND LARGER: 1-1/2 INCH
- INSULATION SHALL RUN CONTINUOUSLY THROUGH WALLS, PARTISANS, ROOF, AND/OR FLOOR.
- PIPE INSULATION JACKETING
 - ALL INSULATED PIPING SHALL INCLUDE A FACTORY APPLIED ALL SERVICE JACKETING WITH VAPOR BARRIER FOR PIPING LOCATED INDOORS.
 - ALUMINUM JACKETING WITH VAPOR BARRIER FOR PIPING LOCATED OUTDOORS.
 - PVC PRE-MOLDED JACKET COVERS FOR VALVES AND FITTINGS.
 - ON COLD SYSTEMS, ALL PENETRATIONS OF THE JACKET VAPOR BARRIER AND EXPOSED ENDS SHALL BE SEALED WITH VAPOR BARRIER MASTIC IN A CLEAN AND PROFESSIONAL MANNER. IF HUMIDITY EXCEEDS 90% ADDITIONAL VAPOR RETARDING COATING OR JACKET MAY BE NECESSARY.
- GAS PIPING AND REGULATOR
 - SCHEDULE 40 BLACK STEEL. NO FLEXIBLE PIPING IS ALLOWED.
 - NPT CONNECTION: PIPING DIAMETERS UP TO 2.5 INCH.
 - WELDED CONNECTION: PIPING DIAMETERS 3 INCHES AND OVER.
 - GAS FIRE EQUIPMENT SHALL EACH HAVE A BALL VALVE ISOLATOR. INSTALL SEDIMENT TRAP IN VERTICAL DROP PRIOR TO REGULATOR.
 - VENT REGULATOR/EQUIPMENT AS REQUIRED BY CODE. INSTALL STAINLESS STEEL INSECT SCREEN OVER VENT TERMINATE OUTDOORS.
 - PAINT: RUST INHIBITING, COLOR: YELLOW. LABEL: NATURAL GAS
- PIPPING AND CONDUIT SUPPORT
 - ALL PIPING AND CONDUIT SHALL BE PROPERLY SUPPORTED. WOOD PRODUCTS ARE NOT PERMITTED FOR SUPPORTS.
 - PIPPING AND CONDUIT LOCATED ON ROOF OR FLOOR SHALL BE SUPPORTED WITH 8-LINE DURA-BLOCK OR EQUAL. SUPPORT SYSTEM SHALL BE COMPATIBLE WITH ROOFING SYSTEM. PIPING SUPPORTED MORE THAN 24 INCHES AFF SHALL BE SUPPORTED WITH ADJUSTABLE HEIGHT SYSTEMS, ANCHORED TO FLOOR, WITH RAILS AND/OR SADDLES TO SUPPORT AND ANCHOR PIPING. SUPPORT AT 10 FEET ON CENTER AND WITHIN 12 INCHES IN EACH CHANGE OF DIRECTION.
 - ALL SUSPENDED PIPING SHALL BE SUPPORTED WITH CLEVIS HANGERS OR TRAPEZE SYSTEM AT 10 FEET ON CENTER AND WITHIN 12 INCHES IN EACH CHANGE OF DIRECTION. PROVIDE ADDITIONAL HANGERS OR SUPPORTS TO PREVENT WEIGHT OF PIPING BEING PLACED ON EQUIPMENT. ALL SUPPORTS SYSTEMS SHALL BE SUITABLE FOR WEIGHT INTENDED.
 - ALL INSULATED PIPING SHALL HAVE SADDLES AT EACH HANGER (3 PIPE DIAMETER IN LENGTH).
 - IT IS NOT ACCEPTABLE TO SUPPORT FROM EXISTING PIPE, CONDUIT, OR DUCTWORK.

COMBUSTION EQUIPMENT VENTING

- CATEGORY IV APPLIANCE - DIRECT VENT EQUIPMENT
 - COMBUSTION AIR VENTING MATERIAL SHALL BE SCHEDULE PVC, CPVC, OR STAINLESS STEEL WITH GLUED/WELDED JOINTS.
 - FLUE EXHAUST VENTING MATERIAL SHALL BE SCHEDULE CPVC OR STAINLESS STEEL WITH GLUED/WELDED JOINTS.
 - FITTINGS SHALL BE CLEANED, PRIMED AND GLUED PER INDUSTRY STANDARDS AND MANUFACTURERS RECOMMENDATIONS.
 - REFERENCE MANUFACTURERS LITERATURE FOR ROUTING LIMITATIONS, TERMINATION METHODS, AND VENTING CAPS. INSTALL TEE TYPE VENT CAP ON FLUE EXHAUST TERMINATION. A.

ELECTRICAL AND CONTROLS

- MAKE SAFE ANY USED ELECTRICAL SERVICE. LABEL PANEL AS SPARE.
- ALL ELECTRICAL CABLING SHALL BE INSTALLED FROM JUNCTION BOX OR ELECTRICAL PANEL IN HARD METAL CONDUIT.
- ALL OUTDOOR ELECTRICAL AND CONTROLS SHALL BE ENCLOSED IN WEATHER PROOF ENCLOSURES.
- FINAL EQUIPMENT CONNECTION IS ALLOWED IN FLEXIBLE LIQUID-TIGHT CONDUIT OF NO MORE THAN 3 FEET.
- CONDUIT SHALL BE BONDED IF NECESSARY. CONTRACTOR SHALL FIELD VERIFY.
- WIRE SPLICING MUST BE ENCLOSED IN A CODE APPROVE ENCLOSURE.
- CONTROL WIRING SHALL BE FLENUM RATED. INSTALL IN HARD METAL CONDUIT IF REQUIRED BY LOCAL CODE AND WHEN INSTALL OUTDOORS.

ELECTRIC MOTORS

- MOTORS UTILIZING VARIABLE FREQUENCY DRIVES SHALL HAVE BEARING PROTECTION RINGS (GROUNDING RINGS) INSTALLED.
- ALL MOTORS OPERATING HVAC EQUIPMENT SHALL BE OF THE NON-OVERLOADING TYPE.

IDENTIFICATION

- ALL EQUIPMENT AND PIPING SHALL BE LABELED. EQUIPMENT SHALL BE IDENTIFIED WITH A PLASTIC UV RESISTANT NAME PLATE WITH BLACK FOREGROUND AND WHITE LETTERING. PIPING SHALL BE LABELED WITH FLUID TYPE ABBREVIATION AND DIRECTIONAL ARROWS. PIPING SHALL BE PAINTED TO MATCH EXISTING. LABELING SHALL BE PER ANSI/ASME STD A13.1.

EQUIPMENT INSTALLATION AND CONNECTIONS

- MAINTAIN CLEARANCES AROUND EQUIPMENT PER MANUFACTURERS' REQUIREMENTS.

- ALL EQUIPMENT CONNECTIONS SHALL BE PER THE MANUFACTURERS' RECOMMENDATIONS, STATE, AND LOCAL CODE. PROVIDE AND INSTALL ALL SPECIALTIES AS REQUIRED BY THE MANUFACTURE.
- ALL FINAL CONNECTIONS TO EQUIPMENT SHALL BE MADE WITH FLANGES OR UNIONS.
- CONTRACTOR SHALL CONFIGURE ALL CONNECTIONS TO BE EASILY REMOVABLE FOR MAINTENANCE IF NECESSARY.
- DI-ELECTRIC UNION SHALL BE USED AT THE CONNECTION OF DISSIMILAR METALS.
- PROVIDE FLEX CONNECTION TO ALL BASE MOUNTED HYDRONIC PUMPS OVER 10 HP AND AIR SIDE EQUIPMENT.

TEST, ADJUSTMENT, AND BALANCE

- ALL HVAC SYSTEM PERFORMANCE SHALL BE TESTED, ADJUSTED, AND BALANCED (TAB) BY A CERTIFIED THIRD PARTY AABC OR NEBB CONTRACTOR. TEST EQUIPMENT ACCURACY/CALIBRATION SHALL MEET THE STANDARDS ESTABLISHED BY AABC OR NEBB.
- THE TAB CONTRACTOR SHALL MAINTAIN CERTIFICATION THROUGHOUT THE ENTIRE CONTRACT PERIOD.
- THE TAB CONTRACTOR SHALL PLAN AND ISSUES A FINAL REPORT IN ACCORDANCE WITH AABC OR NEBB. THE FINAL REPORT SHALL BE SIGNED AND BEAR THE SEAL OF THE TAB STANDARD. FINAL BALANCE SHALL BE WITHIN 10% OF VALUE SPECIFIED.
- TAB CONTRACTOR SHALL PERFORM ALL NECESSARY TESTING AND ADJUSTMENTS UNTIL FINAL ACCEPTANCE BY PROJECT MANAGER.

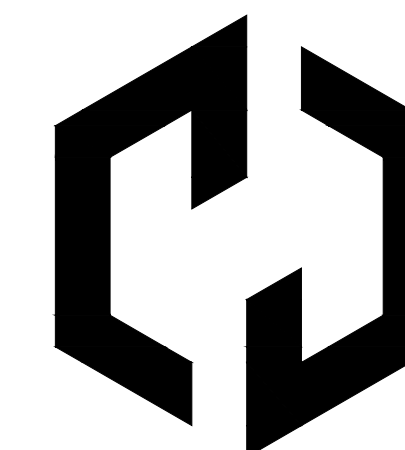

Ossa
STUDIO

4539 HEDGEMORE DRIVE, SUITE 101
CHARLOTTE, NC 28209
704.990.2553
WWW.OSSASTUDIO.COM

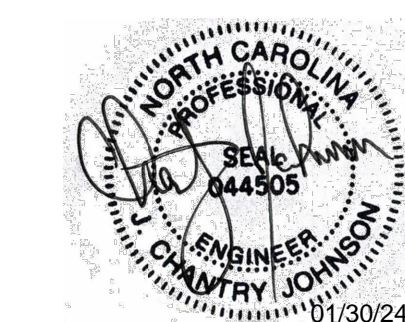

PROJECT TEAM

General Contractor
ECCLESIA CONSTRUCTION
www.ecclesiaincconstruction.com
803.327.5670

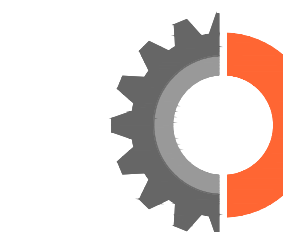

ENGITECTURE
CONSULTING ENGINEERS
ENGITECTURE, PLLC
NC License No. P-1625

4539 Hedgemore Drive, Suite 102
Charlotte, NC 28209
704-287-2193
PROJ# 23253

△ Date Description

01/30/2024 ISSUE FOR CONSTRUCTION

Project Name



community church
making church come alive
658 GRAHAM ROAD
SANFORD NC 27311

Client

3D COMMUNITY CHURCH

Project Number

23024.00

Description

SPECIFICATIONS - HVAC

Scale

NA

M00.02

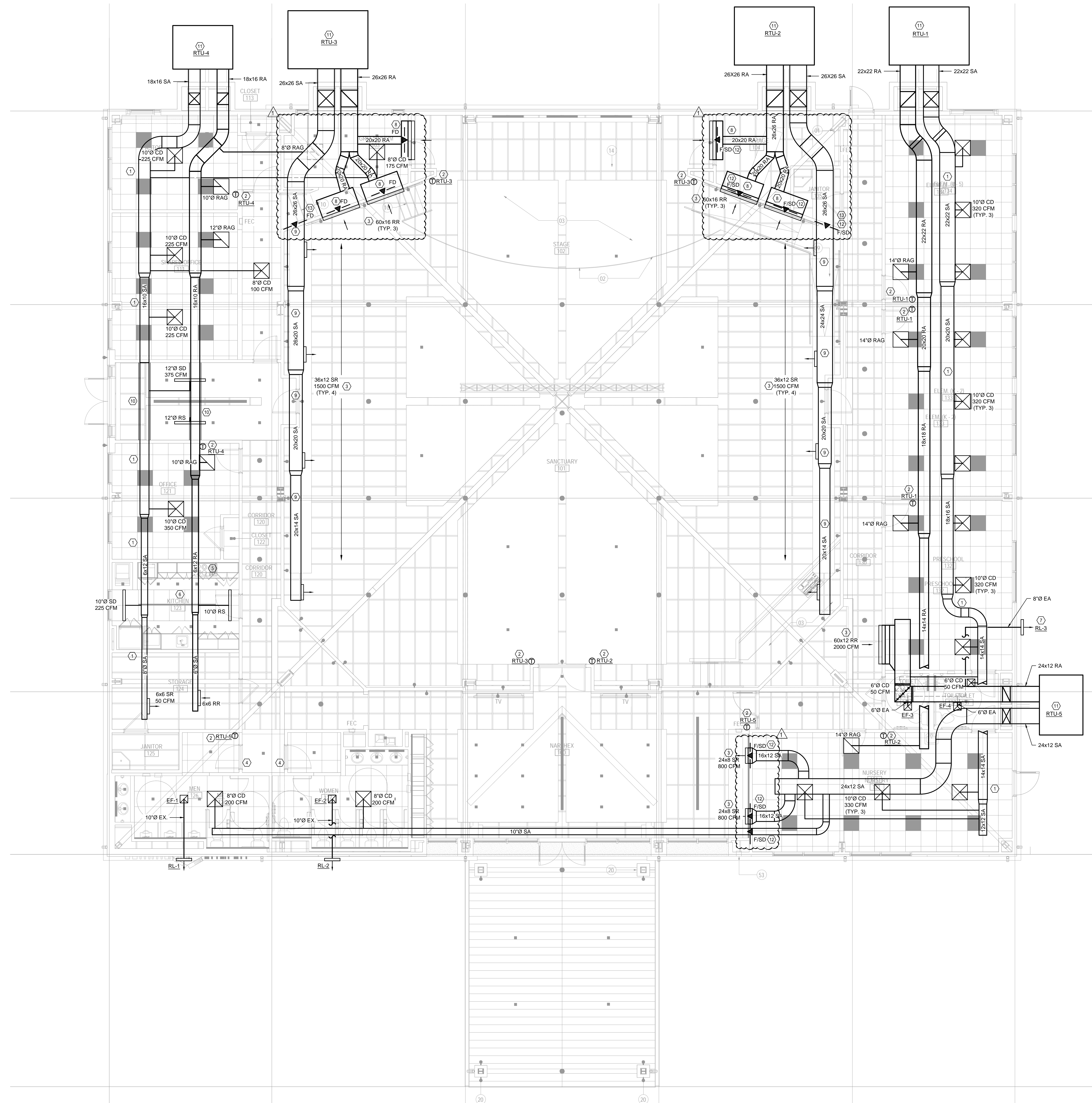

- LEGEND NOTES
(APPLY TO THIS SHEET ONLY)
- COORDINATE LOW PRESSURE DUCT WORK LOCATION AND SIZE WITH STRUCTURAL BEAMS. OFFSET/FLATTEN AS REQUIRED. SEE SPECIFICATION SECTION 16.1 FOR DUCT SIZING CRITERIA. LOCATION SHOWN IS DIAGRAMMATIC AND NOT INTENDED TO SHOW EXACT, FINAL LOCATION.
 - PROVIDE AVERAGING THERMOSTAT IN APPROXIMATE LOCATION. FINAL STYLE AND LOCATION SHALL BE APPROVED BY ARCHITECT AND OWNER.
 - FINAL STYLE, LOCATION, ELEVATION AND FINISH SHALL BE APPROVED BY THE ARCHITECT AND OWNER.
 - PROVIDE LOUVER IN DOOR FOR TRANSFER AIR. LOUVER SHALL HAVE A MINIMUM FREE AREA OF 1.0 SQFT. FINAL STYLE AND FINISH SHALL BE APPROVED BY THE ARCHITECT AND OWNER.
 - PROVIDE DOMESTIC RANGE HOOD IN THIS APPROXIMATE LOCATION. SEE ARCHITECTURAL DRAWINGS FOR ADDITIONAL DETAILS.
 - WARNING OF FOODS ONLY IN THIS AREA. THERE SHALL BE NO COOKING ON THE PREMISES IN COMPLIANCE WITH THE NORTH CAROLINA MECHANICAL CODE.
 - RELIEF LOUVER TO BE MOUNTED UP HIGH ON WALL 10 FT AWAY FROM THE OUTSIDE AIR OF THE GROUND MOUNTED PACKAGED RTU IN COMPLIANCE WITH THE NORTH CAROLINA MECHANICAL CODE.
 - PROVIDE FULL SIZE PLENUM BOX ON THE BACK OF THE RETURN REGISTER. COORDINATE WITH STRUCTURE.
 - DUCT WORK SHALL BE MOUNTED IN ARCHITECTURAL SOFFIT. SEE ARCHITECTURAL PLANS FOR ADDITIONAL DETAILS. COORDINATE WITH FINAL CONSTRUCTION. SEE SPECIFICATION SECTION 16.1 FOR DUCT SIZING CRITERIA FOR ALTERNATE DUCT SIZES AS REQUIRED.
 - PROVIDE FIRE WRAP OR OTHER PREAPPROVED UL ASSEMBLY AROUND DUCT WORK AS A MEANS TO SEPARATE THE DUCT WORK FROM THE EXIST PASSAGEWAY IN COMPLIANCE WITH THE NORTH CAROLINA BUILDING AND MECHANICAL CODES AS ALLOWED BY THE LOCAL AUTHORITY HAVING JURISDICTION.
 - HVAC UNIT SHALL BE MOUNTED ON MINIMUM OF A 4" THICK CONCRETE HOUSE KEEPING. COORDINATE FINAL HOUSE KEEPING PAD LOCATION AND SIZE WITH PURCHASED EQUIPMENT. DUCT TRANSITIONS INTO BUILDING AND FINAL INSTALLED CONDITIONS.
 - PENETRATIONS THROUGH HORIZONTAL EXITS SHALL BE PROTECTED WITH A FIRE/SMOKE DAMPER IN COMPLIANCE WITH NCMC 607.5.2.1. SEE ARCHITECTURAL PLANS FOR ADDITIONAL DETAILS.
 - DUCT SHALL PASS PERPENDICULAR TO WALL FOR INSTALLATION OF FIRE/SMOKE DAMPER. COORDINATE WITH WALL FRAMING. OFFSET TRANSITION DUCT AS REQUIRED.



4539 HEDGEMORE DRIVE, SUITE 101
CHARLOTTE, NC 28209
704.990.2553
WWW.OSSASTUDIO.COM

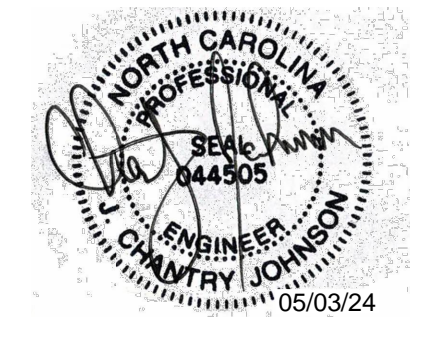

PROJECT TEAM

General Contractor
ECCLESIA CONSTRUCTION
www.ecclesiainc.com
803.327.5670

ENGINECTURE
CONSULTING ENGINEERS
ENGINECTURE, PLLC
NC License No. P-1625

4539 Hedgemore Drive, Suite 102
Charlotte, NC 28209
704-287-2193
PROJ# 23253

Date	Description
01/30/2024	ISSUE FOR CONSTRUCTION
05/03/2024	ARCHITECTURAL REVISION 1

Project Name

3D
community church
making church come alive

658 GRAHAM ROAD
SANFORD NC 27311

Client

3D COMMUNITY CHURCH

Project Number

23024.00

Description

FLOOR PLAN - HVAC

Scale

SEE PLANS

M01.01

1 FLOOR PLAN - HVAC
M01.01 SCALE: 3/16" = 1'-0"

11/30/2023 4:49:42 PM Z:\Photos\Andrew.mcdonald\Revit Local\2024\00_3D Community Church_andrew.mcdonald\FLOOR.CAD

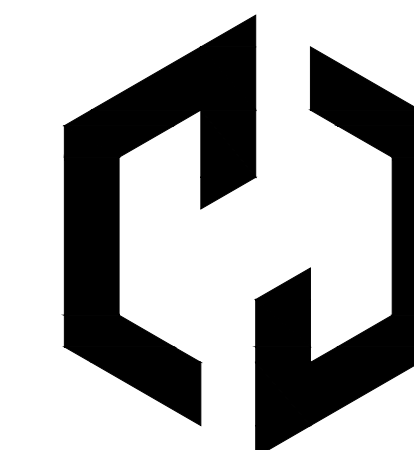

Ossa Studio

4539 HEDGEMORE DRIVE, SUITE 101
CHARLOTTE NC 28209
704.990.2653
WWW.OSSASTUDIO.COM

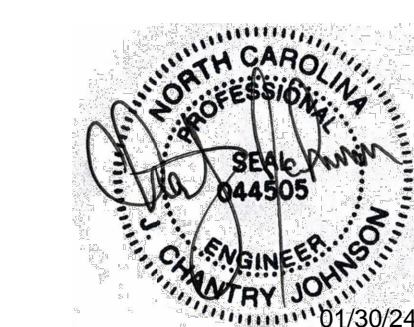

PROJECT TEAM

General Contractor
ECCLÉSIA CONSTRUCTION
www.ecclésiainc.com
803.327.5670

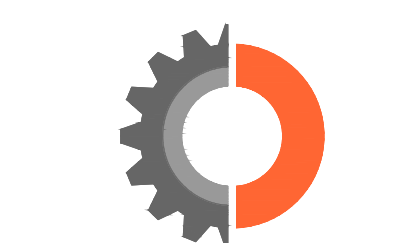

ENGITECTURE CONSULTING ENGINEERS
ENGITECTURE, PLLC
NC License No. P-1625

4539 Hedgemore Drive, Suite 102
Charlotte, NC 28209
704-287-2193
PROJ# 23253

Date Description

01/30/2024 ISSUE FOR CONSTRUCTION

Project Name



community church
making church come alive

658 GRAHAM ROAD
SANFORD NC 27311

Client

3D COMMUNITY CHURCH

Project Number

23024.00

Description

SCHEDULES - HVAC

Scale

NA

M06.01

©2023 Ossa Studio

Ventilation Sizing Summary for RTU-1

1. Summary
Ventilation Sizing Method ASHRAE Std 62.1-2016
Design Condition Heating operation
Occupant Diversity (D) 0.500
Uncorrected Outdoor Air Intake (You) 491 CFM
System Ventilation Efficiency (Ev) 0.651
Outdoor Air Intake (Vot) 754 CFM

2. Space Ventilation Analysis

Table with 12 columns: Zone Name / Space Name, Mult., Supply Air (CFM), Space Floor Area (Sq Ft), Area Outdoor Air Rate (CFM/Sq Ft), Time Averaged Occupancy (Pz), People Outdoor Air Rate (Rp), Air Distribution Effectiveness (Ea), Space Outdoor Air (CFM), Breathing Zone Outdoor Air (CFM), Space Ventilation Efficiency (Evz). Rows include ELEM (3-5), ELEM (K-2), PRESCHOOL, PRESCHOOL TOILET, HALL TOILET, NURSERY, and Totals (incl. Space Multipliers).

Ventilation Sizing Summary for RTU-2&3

1. Summary
Ventilation Sizing Method ASHRAE Std 62.1-2016
Design Condition Heating operation
Occupant Diversity (D) 1.000
Uncorrected Outdoor Air Intake (You) 2309 CFM
System Ventilation Efficiency (Ev) 0.843
Outdoor Air Intake (Vot) 2450 CFM

2. Space Ventilation Analysis

Table with 12 columns: Zone Name / Space Name, Mult., Supply Air (CFM), Space Floor Area (Sq Ft), Area Outdoor Air Rate (CFM/Sq Ft), Time Averaged Occupancy (Pz), People Outdoor Air Rate (Rp), Air Distribution Effectiveness (Ea), Space Outdoor Air (CFM), Breathing Zone Outdoor Air (CFM), Space Ventilation Efficiency (Evz). Rows include SANCTUARY, STORAGE NORTH, JANITOR NORTH, and Totals (incl. Space Multipliers).

Ventilation Sizing Summary for RTU-4

1. Summary
Ventilation Sizing Method ASHRAE Std 62.1-2016
Design Condition Heating operation
Occupant Diversity (D) 0.750
Uncorrected Outdoor Air Intake (You) 129 CFM
System Ventilation Efficiency (Ev) 0.907
Outdoor Air Intake (Vot) 141 CFM

2. Space Ventilation Analysis

Table with 12 columns: Zone Name / Space Name, Mult., Supply Air (CFM), Space Floor Area (Sq Ft), Area Outdoor Air Rate (CFM/Sq Ft), Time Averaged Occupancy (Pz), People Outdoor Air Rate (Rp), Air Distribution Effectiveness (Ea), Space Outdoor Air (CFM), Breathing Zone Outdoor Air (CFM), Space Ventilation Efficiency (Evz). Rows include STORAGE WEST, KITCHEN, OFFICE, SHARED OFFICE, PASTOR, GREEN ROOM, LOBBY, and Totals (incl. Space Multipliers).

Ventilation Sizing Summary for RTU-5

1. Summary
Ventilation Sizing Method ASHRAE Std 62.1-2016
Design Condition Heating operation
Occupant Diversity (D) 0.750
Uncorrected Outdoor Air Intake (You) 153 CFM
System Ventilation Efficiency (Ev) 0.790
Outdoor Air Intake (Vot) 194 CFM

2. Space Ventilation Analysis

Table with 12 columns: Zone Name / Space Name, Mult., Supply Air (CFM), Space Floor Area (Sq Ft), Area Outdoor Air Rate (CFM/Sq Ft), Time Averaged Occupancy (Pz), People Outdoor Air Rate (Rp), Air Distribution Effectiveness (Ea), Space Outdoor Air (CFM), Breathing Zone Outdoor Air (CFM), Space Ventilation Efficiency (Evz). Rows include WEST HALL/NARTHEX/LOB, MENS, WOMENS, JANITOR WEST, and Totals (incl. Space Multipliers).

INTAKE/EXHAUST HOOD SCHEDULE

Table with 10 columns: MARK, LOCATION, TYPE, AIR FLOW (CFM), FREE AREA (SQ. FT.), VELOCITY (1) (FPM), APD (1) IN, DAMPER TYPE, BASIS OF DESIGN (2), NOTES. Rows include RL-1, RL-2, and RL-3.

- NOTES:
1) MAXIMUM, NOT TO EXCEED.
2) PROVIDE BASIS OF DESIGN OR EQUAL.
3) PROVIDE MOTOR OPERATED BACKDRAFT DAMPER AND BIRDSCREEN.

AIR DEVICE SCHEDULE

Table with 7 columns: MARK, TYPE, MAX APD (1) IN WG, MOUNTING, NECK SIZE IN, NC (1), BASIS OF DESIGN (2), NOTES. Rows include CD, RG, EG, SR, and SD.

- NOTES:
1) MAXIMUM NOT TO EXCEED VALUE.
2) PROVIDE BASIS OF DESIGN OR EQUAL.
3) COORDINATE DIFFUSER/GRILLE COLOR WITH ARCHITECT PRIOR TO ORDERING.
4) PROVIDE WITH OPPOSED BLADE DAMPER.
5) SEE MECHANICAL AND ARCHITECTURAL PLANS FOR ADDITIONAL DETAILS AND INFORMATION.
6) THE BACK OF ALL SUPPLY AIR DISTRIBUTION SHALL BE INSULATED OR LINED TO PREVENT CONDENSATION.
7) PROVIDE WITH PLENUM SOUND ATTENUATING BOOT. REFER TO DETAILS FOR ADDITIONAL INFORMATION.

FAN SCHEDULE

Table with 11 columns: MARK, LOCATION, AIR FLOW (2) (CFM), ESP (2) IN, FAN TYPE, DRIVE, NOMINAL POWER (3) (HP), PHASE, VOLT, MOTOR SPEED CONTROL, BASIS OF DESIGN (1), NOTES. Rows include EF-1, EF-2, EF-3, and EF-4.

- NOTES:
1) PROVIDE BASIS OF DESIGN OR EQUAL.
2) DESIGN MINIMUM. FINAL SELECTIONS SHALL MEET OR EXCEED THIS VALUE.
3) PROVIDE FAN GRAVITY BACKDRAFT DAMPER AND SPEED CONTROLLER. SPEED CONTROLLER SHALL BE USED TO BALANCE THE FAN.
4) FAN SHALL BE INTERLOCKED WITH RESTROOM LIGHTING.

PACKAGED AIR CONDITIONER SCHEDULE (ROOFTOP)

Table with 18 columns: MARK, LOCATION, AREA AND/OR BLDG SERVED, TYPE, TOTAL SUPPLY AIR FLOW (CFM), MIN. OUTSIDE AIR FLOW (CFM), EXT. STATIC PRESSURE (1) IN, COOLING CAPACITY (MIN TOTAL CAPACITY (3) MBH, MIN SENS CAPACITY (3) MBH, LAT Db, Wb, Wb, Wb), HEATING CAPACITY (MIN. INPUT (2) KW, EAT Db, LAT Db), ELECTRICAL DATA (UNIT POWER CONNECTION: VOLT, PHASE, MCA, MOCP), BASIS OF DESIGN (7), NOTES.

- NOTES:
1) THIS IS THE SP EXTERNAL TO THE ENTIRE UNIT ASSEMBLY (WET COIL, CASING, CLEAN FILTERS, AND FURNACE LOSSES ARE NOT INCLUDED IN THIS EXT. SP).
2) THIS IS THE MINIMUM OUTPUT CAPACITY (IN MBH FOR GAS AND IN KW FOR ELEC).
3) THIS IS A DESIGN MINIMUM. NOT UNIT CAPACITY.
4) PROVIDE UNIT WITH SMOKE DETECTORS IN COMPLIANCE WITH THE NCMC AND LOCAL AHA.
5) PROVIDE UNIT WITH ECONOMIZER AND BAROMETRIC RELIEF.
6) PROVIDE UNIT WITH HINGED ACCESS DOORS AND SECONDARY MEANS OF CONDENSATE DISPOSAL AS REQUIRED BY NCMC 307.2.3 METHOD 1,2,3 OR 4.
7) PROVIDE BASIS OF DESIGN OR EQUAL.
8) PROVIDE UNIT WITH SINGLE ZONE VAV FUNCTIONALITY.

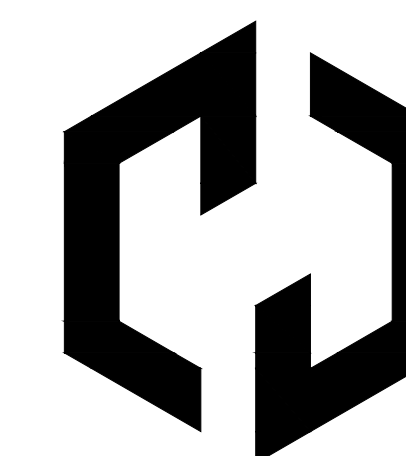

Ossa
STUDIO

4539 HEDGEMORE DRIVE, SUITE 101
CHARLOTTE, NC 28209
704.890.2653
WWW.OSSASTUDIO.COM

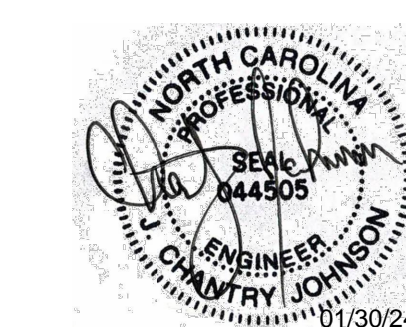

PROJECT TEAM

General Contractor
ECCLESIA CONSTRUCTION
www.ecclesiainc.com
803.327.5670



ENGITECTURE
CONSULTING ENGINEERS
ENGITECTURE, PLLC
NC License No. P-1625

4539 Hedgemore Drive, Suite 102
Charlotte, NC 28209
704-287-2193
PROJ# 23253

Date Description

01/30/2024 ISSUE FOR CONSTRUCTION

Project Name



community church
making church come alive

658 GRAHAM ROAD
SANFORD NC 27311

Client

3D COMMUNITY CHURCH

Project Number

23024.00

Description

DETAILS - HVAC

Scale

NA

M07.01

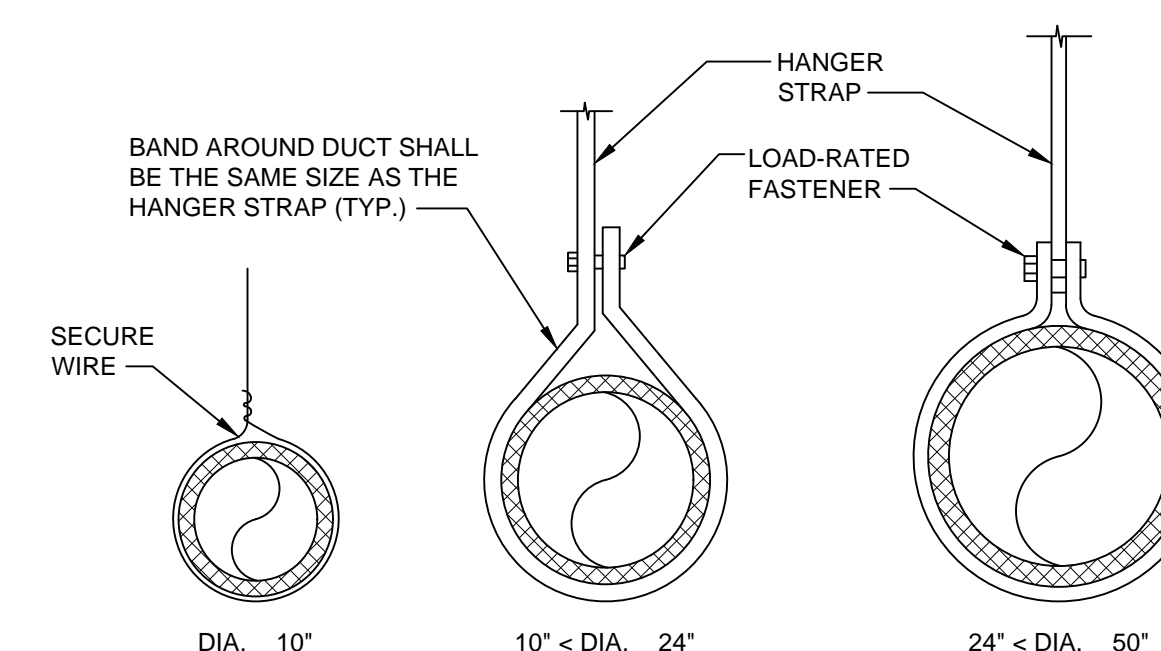

NOTE:
HANGERS SHALL NOT DEFORM DUCT SHAPE.

4 ROUND DUCTWORK SUPPORT DETAIL
M07.01 SCALE: NTS

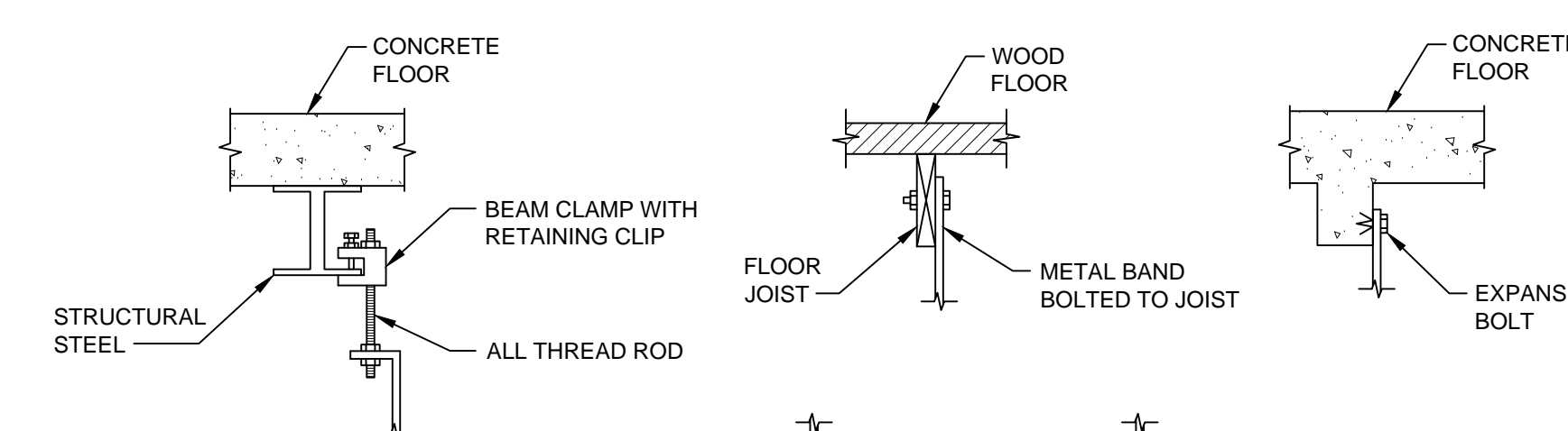

3 LOW PRESSURE RECTANGULAR DUCTWORK SUPPORT DETAIL
M07.01 SCALE: NTS

- NOTES:
1. ALL DUCTWORK HANGER SPACING AND SIZING SHALL BE IN ACCORDANCE WITH THE LATEST SMACNA STANDARDS.
 2. DUCTS SHALL NOT BE HUNG FROM OR SUPPORTED BY HUNG CEILING.
 3. PROVIDE SUPPLEMENTAL BRACING TO LIMIT THE AMPLITUDE OF WALL VIBRATION AND WALL DEFLECTION IN ACCORDANCE WITH PROJECT SEISMIC AND VIBRATION REQUIREMENTS.

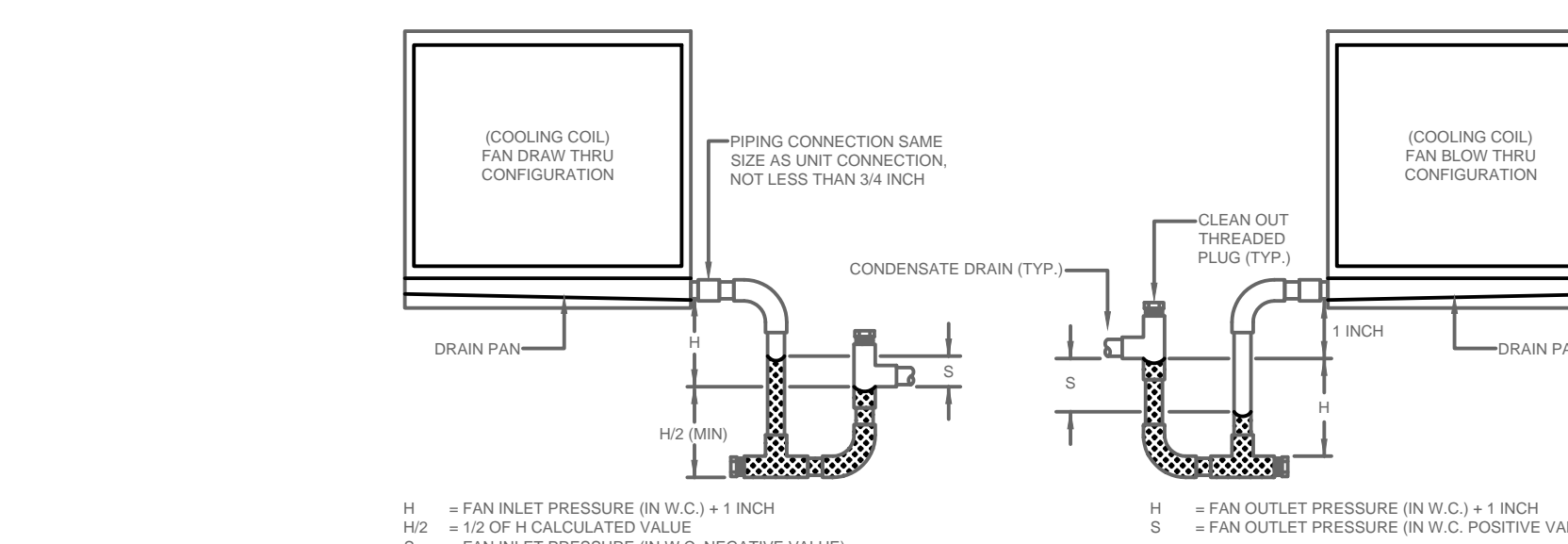

H = FAN INLET PRESSURE (IN W.C.) + 1 INCH
H10 = 1/2 OF H CALCULATED VALUE
H15 = FAN INLET PRESSURE (IN W.C. NEGATIVE VALUE)

PIPE SIZE (INCHES)	UNIT SIZE
1/4"	NOT RECOMMENDED
3/8"	NOT RECOMMENDED
1/2"	NOT RECOMMENDED
3/4"	UP TO 1/2 TONS
1"	UP TO 1/2 TONS
1 1/4"	UP TO 3/4 TONS
1 1/2"	UP TO 3/4 TONS
1 3/4"	UP TO 1 1/4 TONS
2"	UP TO 1 1/4 TONS
2 1/2"	UP TO 1 3/4 TONS
3"	UP TO 2 TONS
3 1/2"	UP TO 2 TONS
4"	UP TO 2 TONS
4 1/2"	UP TO 2 TONS
5"	UP TO 2 TONS

- NOTES:
1. REFERENCE SUBMITTALS FOR FAN PRESSURE. ADDITIONAL 1 INCH ACCOUNTS FOR FIELD INSTALLED CONDITIONS: FILTER LOADING ON DRAW THRU CONFIGURATION AND HIGHER DUCTWORK PRESSURE DROP IN BLOW THRU CONFIGURATION.
 2. EQUIPMENT SHALL BE ELEVATED SUFFICIENTLY TO ALLOW FOR PROPER P-TRAP INSTALLATION.
 3. PIPE CONDENSATE TO NEAREST ROOFPLOOR DRAIN. COORDINATE WITH LOCAL JURISDICTION/UTILITY TERMINATION OF CONDENSATE TO SANITARY AND/OR SEWER.
 4. INSULATE CONDENSATE PIPING LOCATED INDOORS WITH A CEILING RETURN PLENUM OR AREA WITH HIGH HUMIDITY.
 5. MATERIAL: TYPE L COPPER.
 6. PROVIDE FLOAT SWITCH IN DRAIN PAN OR PROVIDE ALTERNATE MEANS TO MEET THE INTENT OF 2018 NCAC 307.2.3 OR APPLICABLE CODE.

2 CONDENSATE DRAIN DETAIL
M07.01 SCALE: NTS

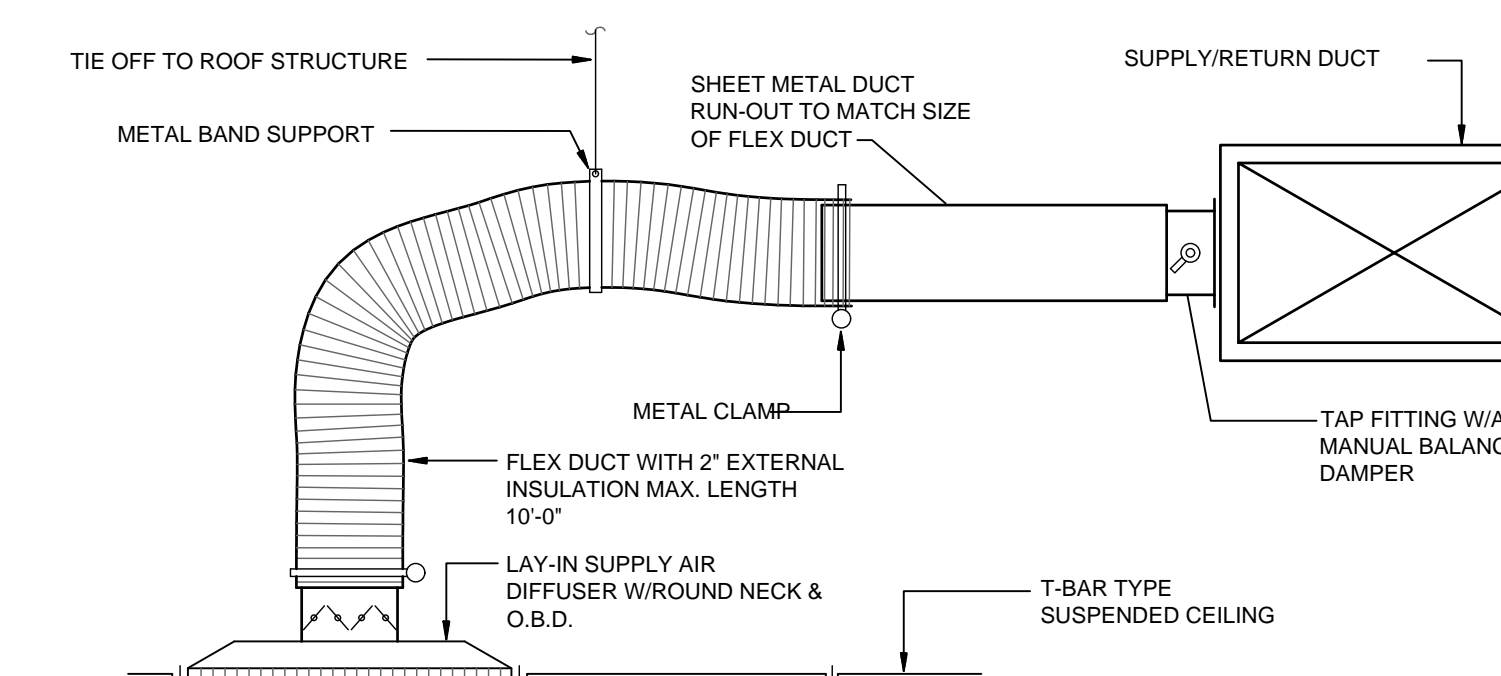

1 AIR DISTRIBUTION DETAIL
M07.01 SCALE: NTS

- NOTE:
1. ALL MANUAL VOLUME DAMPERS LOCATED ABOVE INACCESSIBLE CEILINGS (INCLUDING CALKED ACOUSTICAL CEILING TILE) SHALL BE PROVIDED WITH REMOTE MEANS OF BALANCING.
 2. INSULATE THE BACK OF ALL SUPPLY AIR DIFFUSERS INSTALLED IN DUCTED RETURN SYSTEMS OR ARE SUBJECT TO CONDITIONS WHERE CONDENSATION CAN OCCUR.
 3. ALL ITEMS INSTALLED IN A RETURN AIR PLENUM SHALL BE PLENUM RATED.
 4. PROVIDE SUPPORTS FOR DUCT WORK IN ACCORDANCE WITH NCMC 603.10.

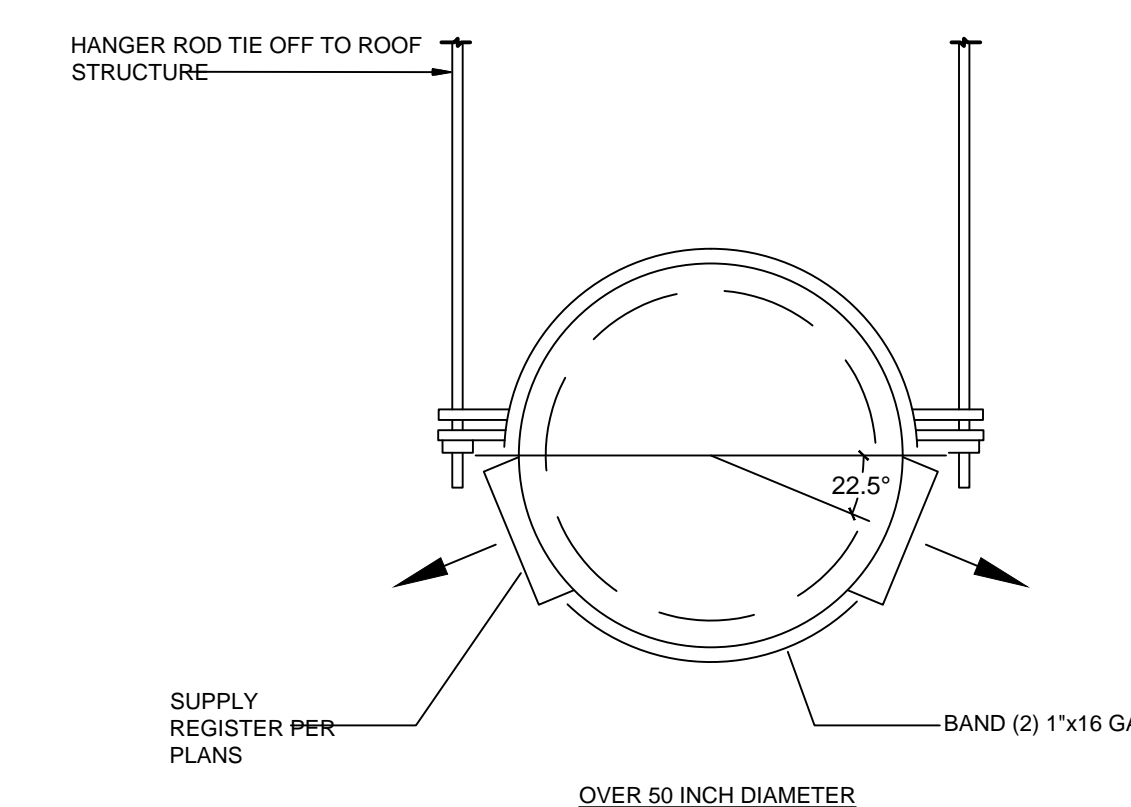

- NOTE:
1. PROVIDE SUPPORTS FOR DUCT WORK IN ACCORDANCE WITH NCMC 603.10.
 2. DUCT WORK SHALL BE INTERNALLY INSULATED WITHIN 25 FEET OF ANY OPERABLE OPENING TO THE EXTERIOR OR ANY OTHER CONDENSATION WHERE CONDENSATION MAY OCCUR.
 3. DUCT WORK SHALL BE INSTALLED LEVEL AND IN A NEAT AND WORKMAN LIKE FASHION.
 4. SEE SMACNA HVAC DUCT CONSTRUCTION STANDARDS, TABLE 5.2, FOR HANGER SIZE AND SPACING.
 5. SEE SMACNA HVAC DUCT CONSTRUCTION STANDARDS FIG 5-1 & 5-2 (WITH SPECIFIC BUILDING STRUCTURAL ENGINEER APPROVAL WHERE APPLICABLE BASED ON WEIGHT AND SEISMIC CRITERIA) FOR UPPER ATTACHMENT TO BUILDING.
 6. SEE SMACNA HVAC DUCT CONSTRUCTION STANDARDS CHAPTER 5 FOR ADDITIONAL DETAILS AND CONFIGURATIONS.

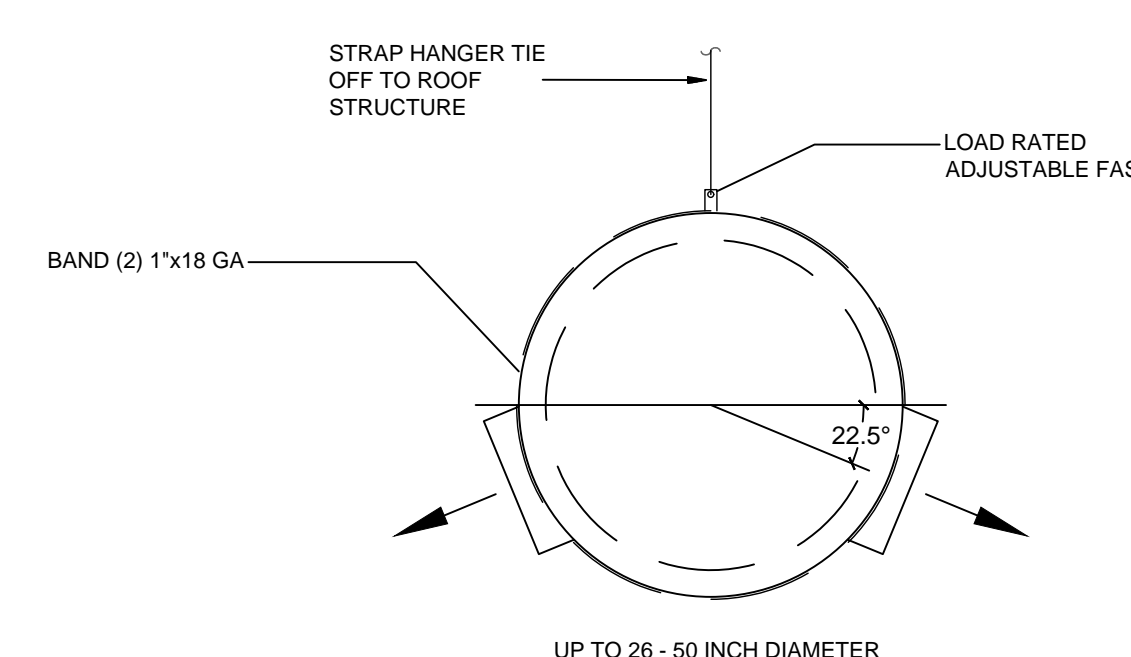

7 SUPPLY REGISTER DETAIL
M07.01 SCALE: NTS

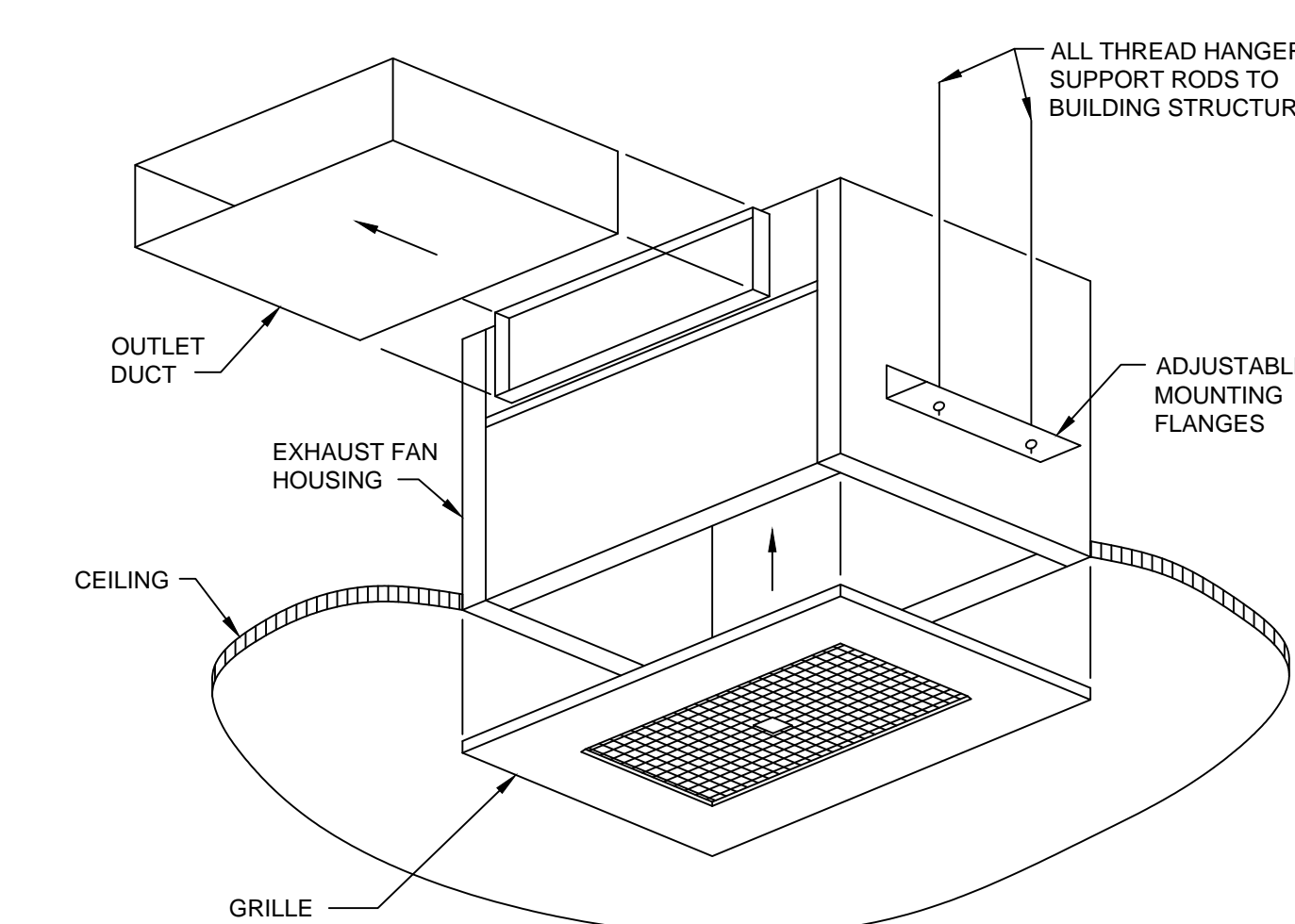

6 CEILING EXHAUST FAN DETAIL
M07.01 SCALE: NTS

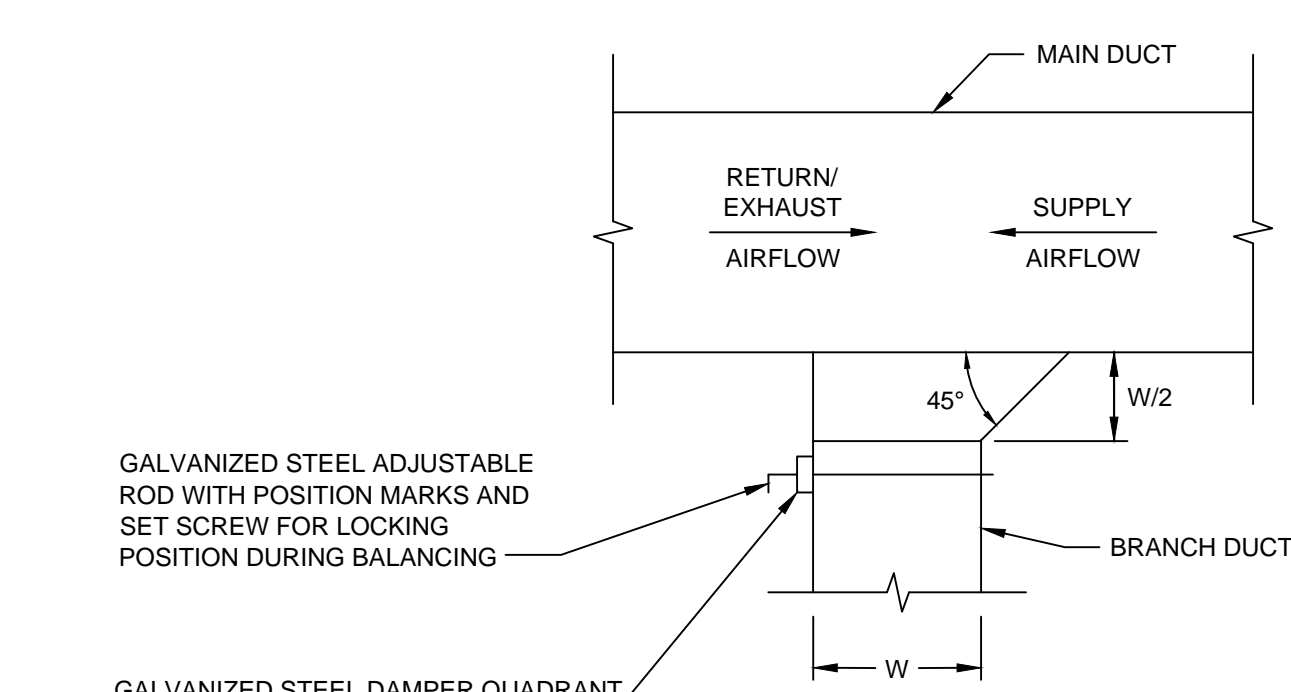

5 TYPICAL DUCTWORK TAKEOFF DETAIL
M07.01 SCALE: NTS

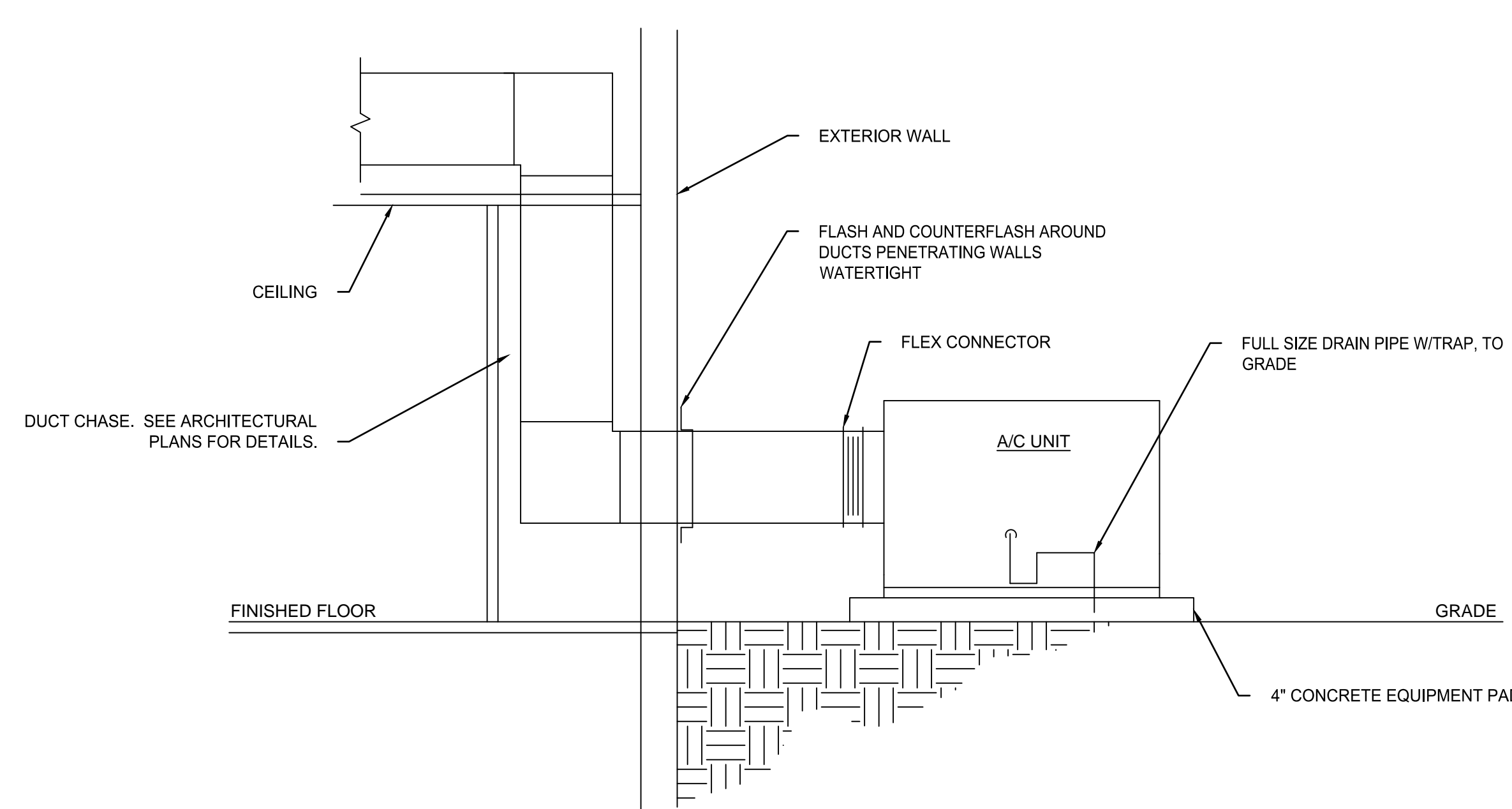

8 GROUND MOUNTED PACKAGED UNIT DETAIL
M07.01 SCALE: NTS

- NOTES:
1. DUCTWORK EXPOSED OUTSIDE SHALL BE INSULATED WITH 2" THICK RIGID EXTERNAL FIBERGLASS INSULATION IN ADDITION TO 1" THICK DUCT LINER. COVER EXTERNAL INSULATION WITH AN ALUMINUM OUTER ENCLOSURE AND SEAL WATER-TIGHT.
 2. AC UNIT SHALL BE INSTALLED LEVEL.
 3. SMOKE DETECTORS SHALL BE IONIZATION TYPE WIRED TO SHUT DOWN THE UNIT UPON ACTIVATION. SMOKE DETECTORS SHALL BE PROVIDED ON SYSTEMS OVER 2000 CFM.

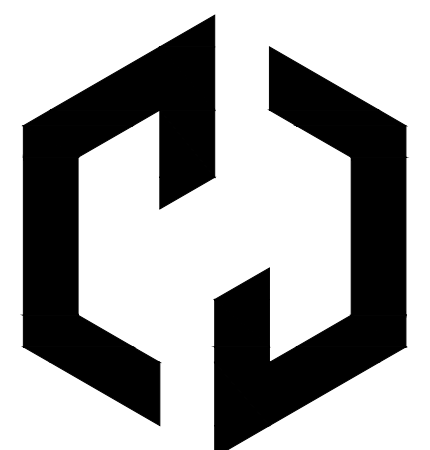

Ossa
STUDIO

4539 HEDGEMORE DRIVE, SUITE 101
CHARLOTTE, NC 28209
704.990.2653
WWW.OSSASTUDIO.COM

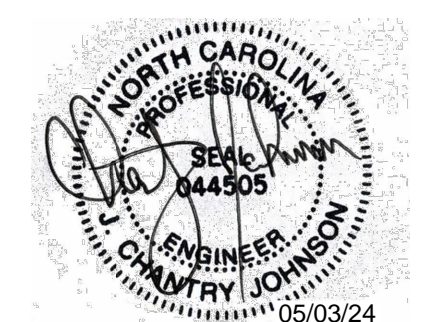

PROJECT TEAM

General Contractor
ECCLESIA CONSTRUCTION
www.ecclesiainc.com
803.327.5670

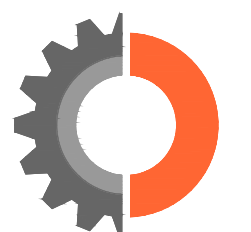

ENGITECTURE
CONSULTING ENGINEERS

ENGITECTURE, PLLC

NC License No. P-1625

4539 Hedgemore Drive, Suite 102
Charlotte, NC 28209
704-287-2193
PROJ# 23253

△ Date Description

01/30/2024 ISSUE FOR CONSTRUCTION

△ 05/03/2024 ARCHITECTURAL REVISION 1

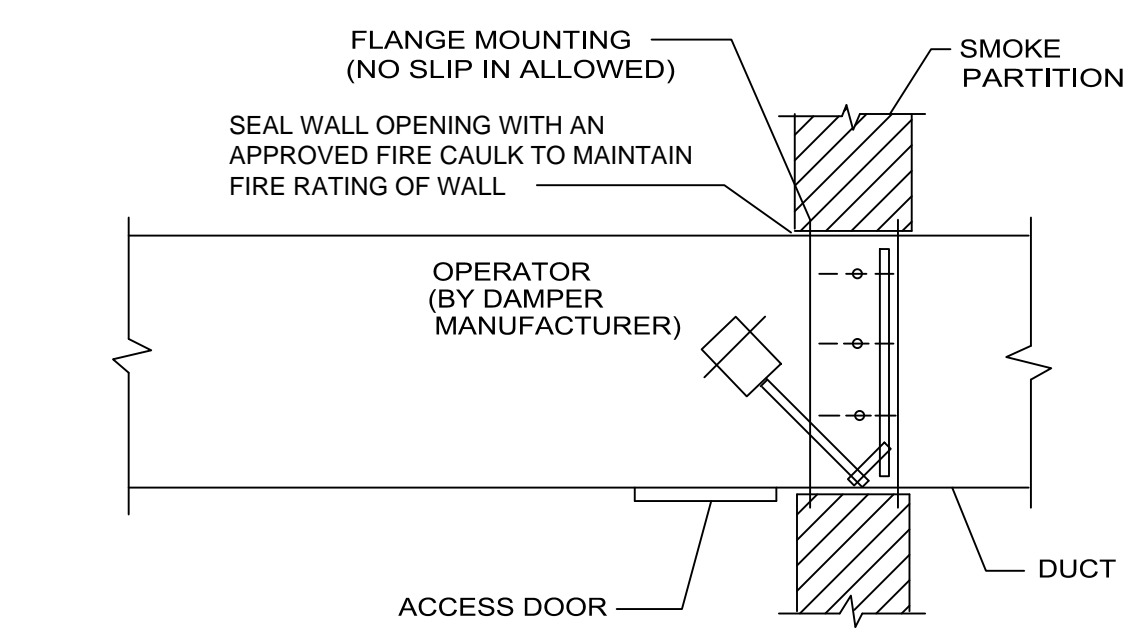

NOTE: DAMPERS SHALL BE INSTALLED AS PER MFG. INSTRUCTIONS.
COMBINATION FIRE/SMOKE DAMPER SHALL BE RUSKIN FSD60, 1 HOUR FIRE DAMPER, UL555 & UL555S WITH MECHANICAL ATTACHED BLADE AND FLEXIBLE STAINLESS STEEL JAMB SEALS. DAMPER SHALL BE U.L. LISTED. INSTALLED IN ACCORDANCE WITH NFPA. ACCESS DOOR SHALL BE RUSKIN MODEL AD02 LOCATED ON ACCESSIBLE SIDE OF WALL. IF ACCESSIBLE CEILING IS NOT AVAILABLE, MECHANICAL CONTRACTOR SHALL PROVIDE ACCESS DOOR IN CEILING (OR WALL) TO MATCH FINISH COLOR.
ALL MODEL NUMBERS ARE RUSKIN. (APPROVED EQUALS ACCEPTABLE)

NOTE: DAMPER ACTUATOR SHALL BE FURNISHED BY THE MANUFACTURER AND FACTORY INSTALLED. COMPLETE ASSEMBLY SHALL BE U.L. RATED.

3 FIRE/SMOKE DAMPER DETAIL
SCALE: NTS

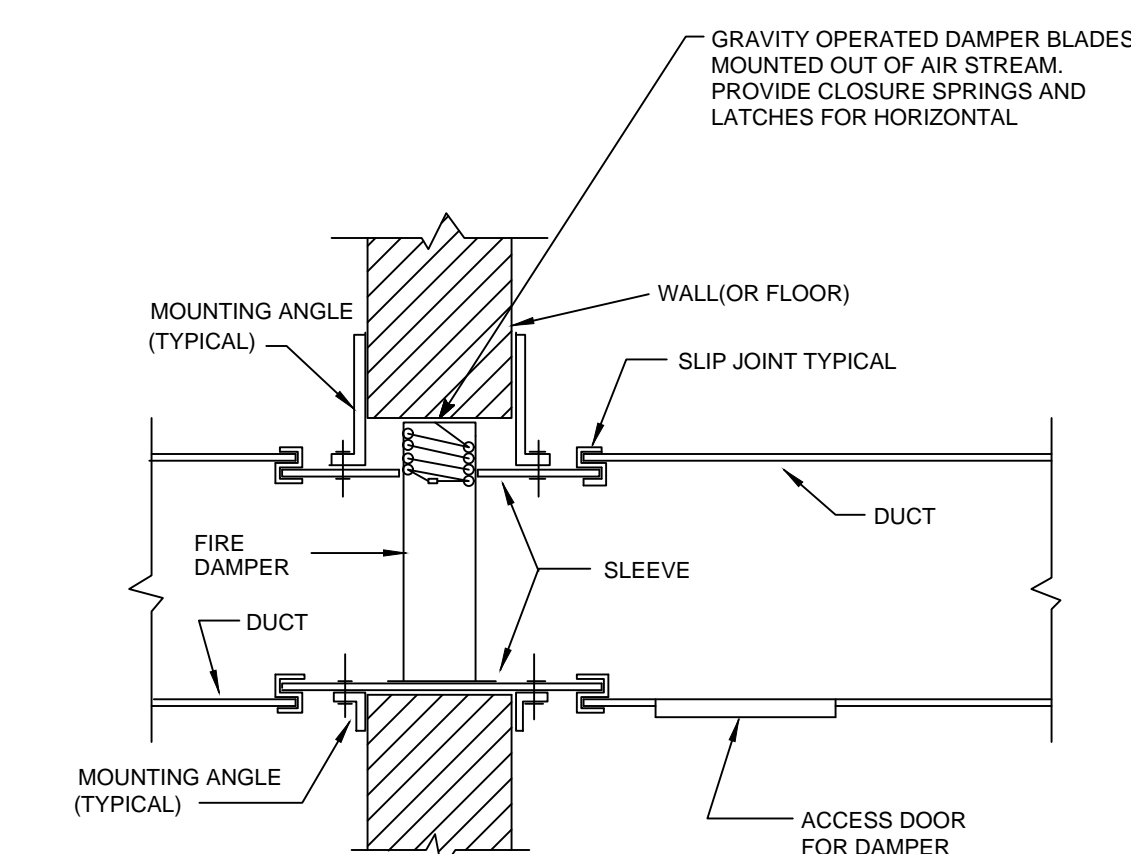

FIRE DAMPER SHALL BE RUSKIN TYPE IB02 STYLE B 1 1/2 HOUR U.L. INSTALLED IN ACCORDANCE WITH NFPA. ACCESS DOOR SHALL BE RUSKIN MODEL AD02 LOCATED ON ACCESSIBLE SIDE OF WALL. IF ACCESSIBLE CEILING NOT AVAILABLE, MECHANICAL CONTRACTOR SHALL PROVIDE ACCESS DOOR IN CEILING (OR WALL) TO MATCH FINISH COLOR. DAMPER SHALL BE EQUIPPED FOR HORIZONTAL OR VERTICAL MOUNTING AS REQUIRED. WHERE ROUND DUCTS REQUIRE A DAMPER, AN ENCLOSURE WITH ROUND DUCT CONNECTION WILL BE REQUIRED WITH TYPE B DAMPER INSIDE. ALL MODELS ARE RUSKIN APPROVED EQUAL ACCEPTABLE.

2 FIRE DAMPER DETAIL
SCALE: NTS

PIPE AND DUCTWORK WALL PENETRATIONS NOTES (MECHANICAL)

- ALL INSULATED METAL PIPING PENETRATING A ONE HOUR OR MORE RATED SLAB SHALL BE SEALED AROUND INSULATION ON BOTH SIDES OF WALL WITH AN APPROVED FIRE STOP WRAP/STRIP MATERIAL. NUMBER OF WRAPS AROUND INSULATION WITHIN WALL OPENING SHALL BE AS REQUIRED FOR THICKNESS OF INSULATION AND MFG. RECOMMENDATIONS. COVER EXPOSED SURFACE AND SEAMS WITH AN APPROVED FIRE STOP CAULK ON BOTH SIDES OF WALL.
- ALL NON-INSULATED METAL PIPING PENETRATING A ONE HOUR WALL OR MORE RATED WALL OR FLOOR SHALL BE SEALED AROUND PIPE ON BOTH SIDES OF WALL WITH AN APPROVED FIRE STOP CAULK. THICKNESS SHALL BE AS RECOMMENDED BY MANUFACTURER FOR WALL RATING REQUIRED TO MAINTAIN U.L. CLASSIFICATION.
- ALL METAL DUCTWORK (LESS THAN 100 SQUARE INCHES) PENETRATING A ONE HOUR WALL OR SMOKE SHALL BE SEALED AROUND DUCT ON BOTH SIDES OF WALL WITH A SHEET METAL COLLAR (SAME GAGE AS DUCT) SECURED TO WALL AND DUCT IN A SMOKE-TIGHT MANNER. DUCT PENETRATIONS EXCEEDING 100 SQUARE INCHES SHALL HAVE A FIRE DAMPER INSTALLED IN THE WALL AS DETAILED.
- ALL DUCTWORK PENETRATING A TWO HOUR OR MORE RATED WALL OR FLOOR SHALL BE PROVIDED WITH A FIRE DAMPER INSTALLED AS DETAILED.
- NO FLEXIBLE DUCTWORK WILL BE ALLOWED TO PENETRATE ONE HOUR WALLS, TWO HOUR WALLS, SMOKE WALLS, CORRIDOR WALLS OR WALLS CLOSED-OFF TO STRUCTURE. METAL RIGID DUCTWORK SHALL EXTEND A MINIMUM OF 5'-0" FROM WALL BEFORE THE FIRST AIR DISTRIBUTION DEVICE IS INSTALLED OR BEFORE FLEXIBLE DUCT IS STARTED. FLEXIBLE DUCTWORK IN A SINGLE DUCT RUN IS ALLOWED ON ONE SIDE OF A RATED WALL BUT NOT BOTH SIDES.
- ACCEPTABLE MANUFACTURERS OF FIRE STOP MATERIALS ARE AS FOLLOWS:
NELSON FLAMESEAL PUTTY
CROUSE-HINDS CABLE BARRIER SYSTEM
DOW CORNING FIRE STOP SEALANT/FOAM
3M FIRE BARRIER
T88 FLAMESEAL
THERMABARRIER BRAND SAFING
ALL MATERIALS AND METHODS OF INSTALLATION SHALL BE U.L. APPROVED FOR THAT INSTALLATION. SHOP DRAWING SUBMITTALS OF MATERIALS AND METHOD OF INSTALLATION, INCLUDING DRAWINGS, SHALL BE SUBMITTED TO THE ARCHITECT FOR REVIEW.
- WHEN A PIPE, WIRE, OR DUCT PENETRATES A NON-RATED SMOKE/TIGHT PARTITION, THE MECHANICAL CONTRACTOR SHALL SEAL AROUND ALL PIPES WIRES AND DUCTS WITH SEALANT MATERIAL TO MAKE IT SMOKE/TIGHT. SEE ARCHITECTURAL PLANS FOR LOCATION OF THESE PARTITIONS.
- SEE ARCHITECTURAL PLANS FOR WALL TYPES.
- ALL RATED WALL PENETRATIONS SHALL BE IN ACCORDANCE WITH UNDERWRITERS LABORATORIES PENETRATION FIRESTOP SYSTEM REQUIREMENTS. ALL MATERIALS USED IN PENETRATION FIRESTOP SYSTEMS SHALL BE APPROVED BY UNDERWRITERS LABORATORIES AND SHALL BE U.L. LABELED.
- PENETRATIONS OF NONRATED WALLS, PARTITIONS AND FLOORS OF NON-COMBUSTIBLE CONSTRUCTION SHALL BE FIRESTOPPED WITH MATERIALS EQUIVALENT TO TWO INCHES OF WOOD. FIRESTOPPING SHALL COMPLY WITH ASTM E-814.

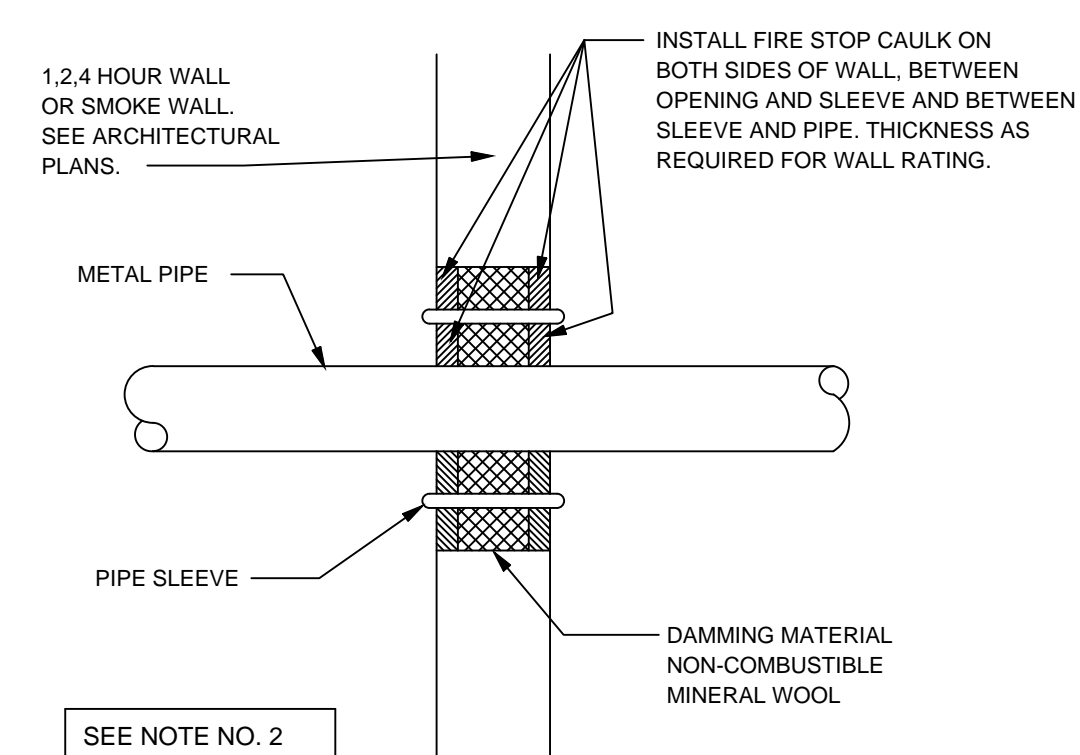

SEE NOTE NO. 2

METAL PIPE PENETRATION-WALL
(U.L. SYSTEM NO. WL5024)

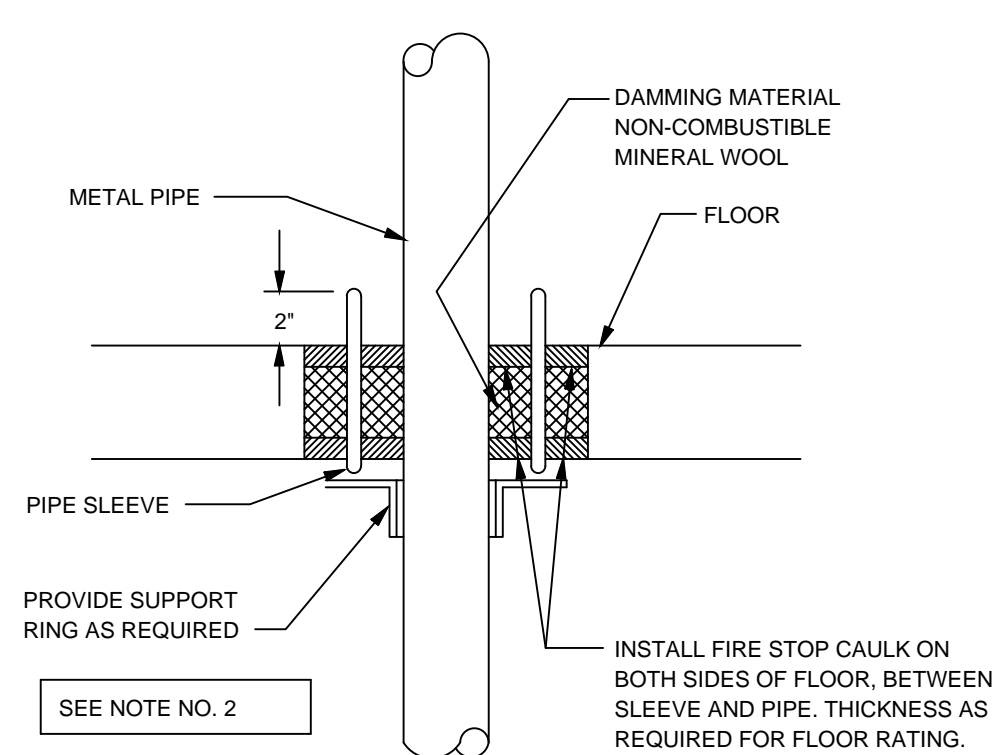

SEE NOTE NO. 2

METAL PIPE PENETRATION-FLOOR
(U.L. SYSTEM NO. CAJ1043) - 1, 2 HR.
(U.L. SYSTEM NO. CAJ1044) - 3, 4 HR.

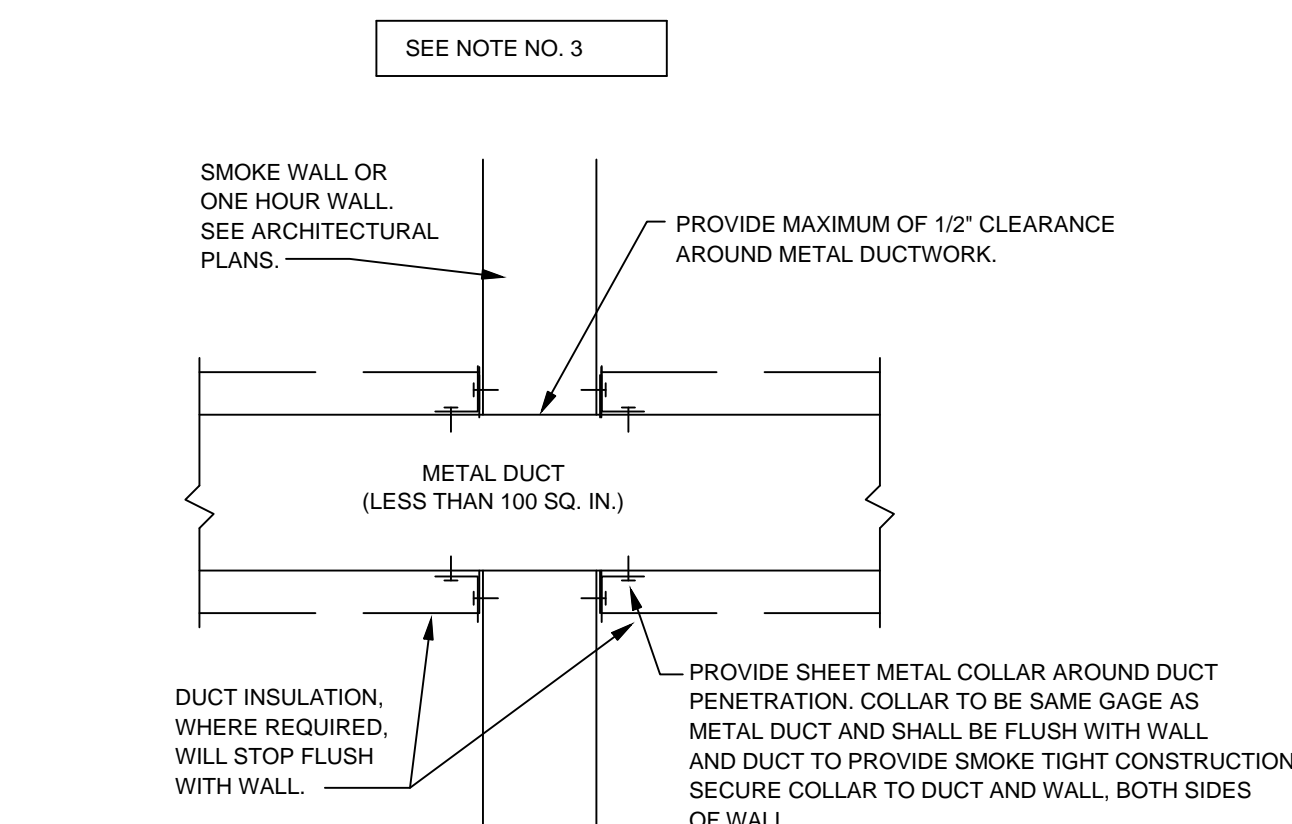

SMOKE OR ONE HOUR WALL-DUCT PENETRATION

NOTE: DUCTS EXCEEDING 100 SQ. IN. SHALL HAVE FIRE DAMPER INSTALLED IN RATED WALL. (SEE FIRE DAMPER DETAIL)

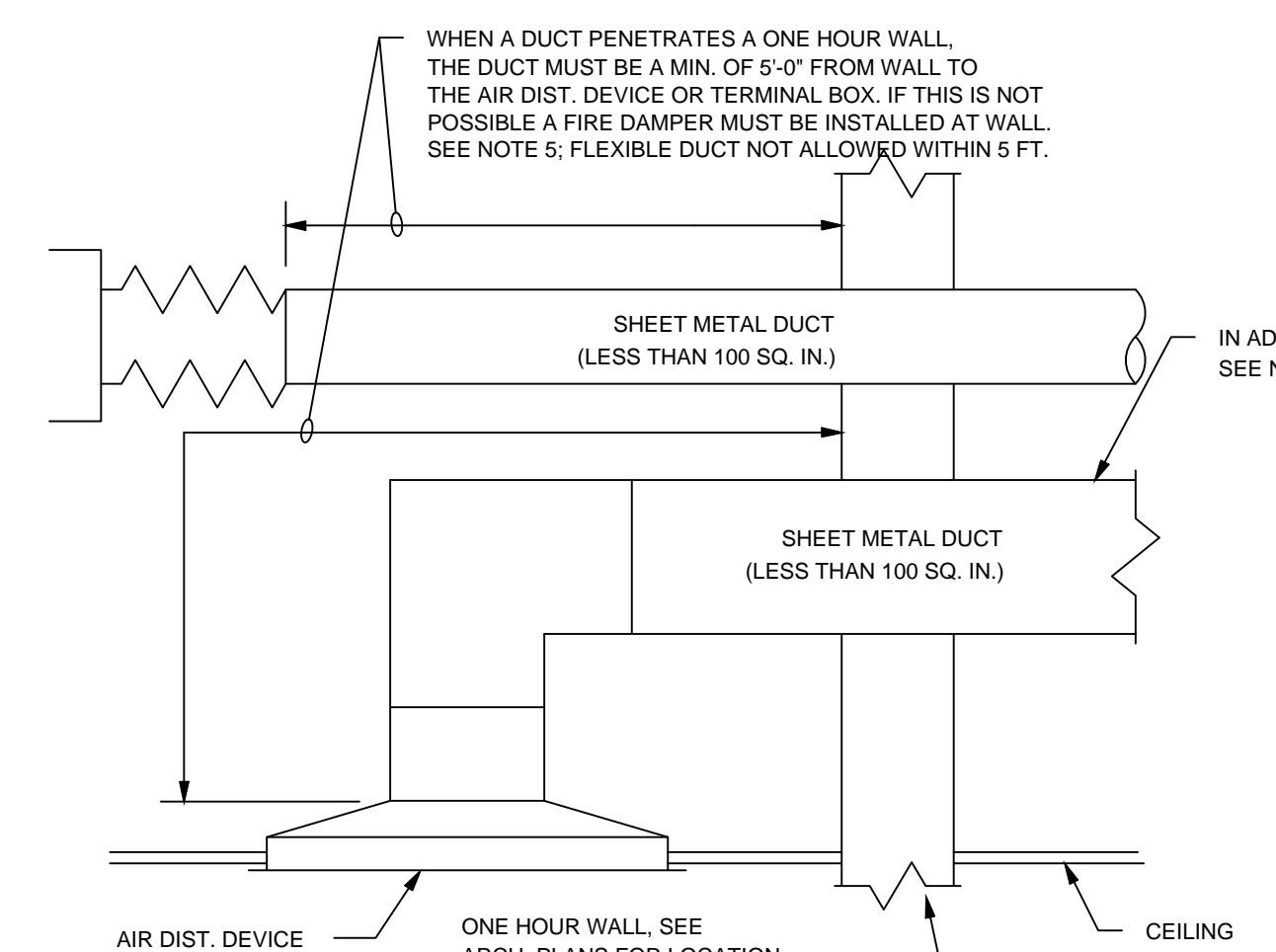

DUCT PENETRATION AT ONE HOUR WALL

NOTE: DUCTS EXCEEDING 100 SQ. IN. SHALL HAVE FIRE DAMPER INSTALLED IN RATED WALL. (SEE FIRE DAMPER DETAIL)

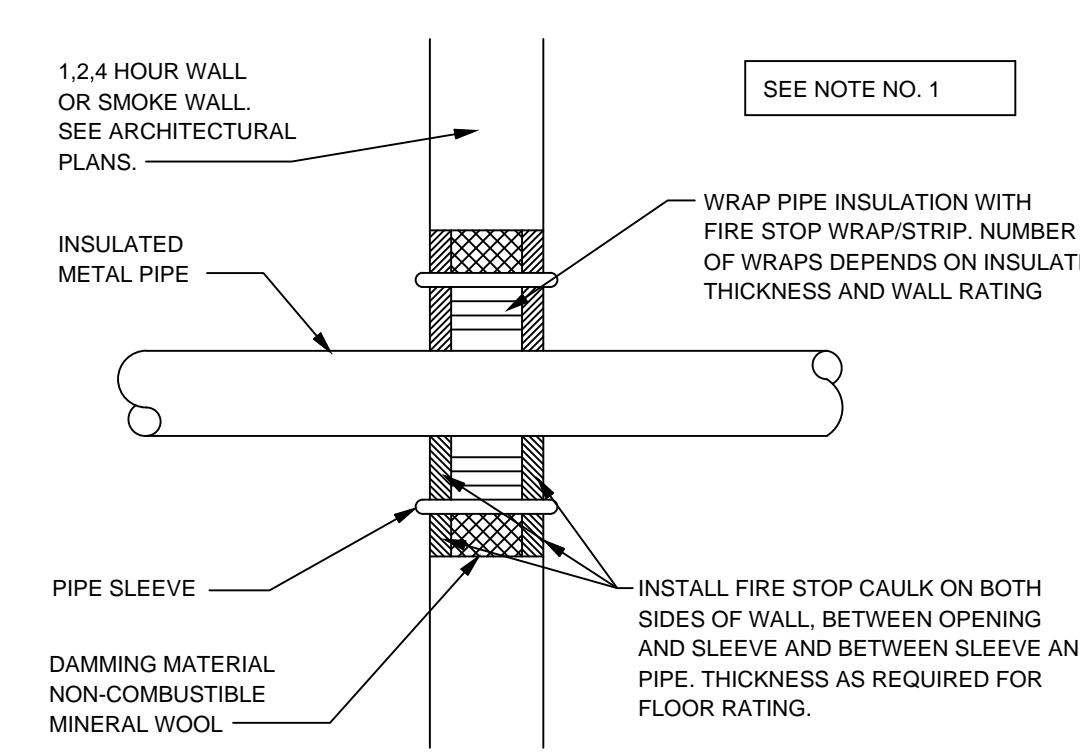

SEE NOTE NO. 1

INSULATED METAL PIPE PENETRATION-WALL
(U.L. SYSTEM NO. WL5024)

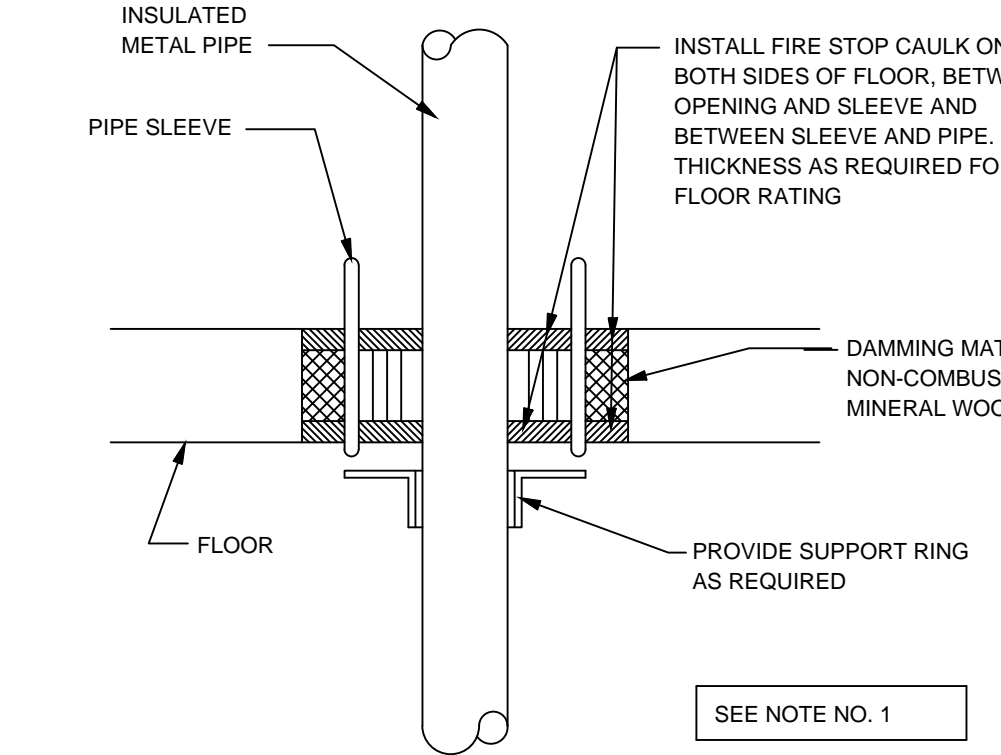

SEE NOTE NO. 1

INSULATED METAL PIPE PENETRATION-FLOOR
(U.L. SYSTEM NO. CAJ1043) - 1, 2 HR.
(U.L. SYSTEM NO. CAJ1044) - 3, 4 HR.

1 UL PENETRATION DETAILS
SCALE: NTS

M07.02