



3821 Powhatan Rd. Clayton, NC 27520  
P.O. Box 39 Clayton, NC 27528  
Phone (919) 359-2239  
Fax (919) 359-2913

**Highland Elementary School  
Classroom Addition  
1915 Buffalo Lake Road  
Sanford, NC**

**FIRE ALARM SYSTEM CUT SHEETS**

**12/20/2022**

LIFE SAFETY &amp; INCIDENT MANAGEMENT

# Fire Alarm Audio Notification System

ANS2 Series



## Overview

The ANS series of products from EDWARDS is a collection of high-performance audio notification systems that provide voice evacuation capability which meets the emergency voice alarm requirements of NFPA 72 for UL listed fire alarm applications. ANS panels are available in 25, 50, or 100 Watt models and include a microphone, amplifier, tone generator, digital message repeater (DMR), and supervisory interface.

These self-contained systems offer robust field-configurable features and are supported by a wide range of accessory equipment that provides application flexibility and reliable performance for new and retrofit installations alike.

Expander panels and modules extend the range of the ANS system to meet the needs of demanding audio applications. Accessory equipment such as zone switchers and remote microphones offer the sophistication of high-end systems for a relatively low cost.

ANS systems are ideal for use with EDWARDS fire alarm control panels when emergency voice alarm service is required. Genesis speakers and speaker-strobes may be used with ANS audio systems to provide a clean and attractive appearance for voice audio applications.

## Standard Features

- Meets NFPA 72 Emergency Voice Alarm requirements
- Easy to use custom configuration software
- Clean dead-front construction
- Integrated field recordable digital message player
- Twenty minute message capacity
- 25, 50, or 100 Watt models available
- Field selectable for either 25 or 70 Vrms speakers
- 120 VAC power supply and battery charger included
- Paging microphone overrides message and tone
- ANS25 and ANS100 systems are 520Hz compliant
- High reliability, low maintenance
- Fully supervised, UL listed
- Easy installation, operation, and configuration
- Built-in alarm and alert signals
- 24-hour backup capability

# Application

National fire codes generally require voice evacuation systems in places of assembly with over 300-person occupancy, in theatres with more than one screen, and in buildings seven stories or higher. ANS Series Audio Notification Systems represent an effective and efficient solution for meeting these requirements.

ANS systems are ideal for new applications with fire control panels that do not provide integrated audio functions. These audio systems also provide the opportunity to add voice evacuation capability to existing fire alarm applications without replacing existing fire alarm control equipment.

The fire alarm control panel works in concert with the ANS audio system, providing all initiating circuitry and a signaling circuit that connects to the ANS. The ANS provides its own internal supervision as well as supervision for its speaker lines.

Faults are reported back to the fire alarm control panel by means of a supervisory circuit, which is connected to a matching EOLR on the ANS. Internal failures and speaker line faults open a con-

tact, which the fire alarm control panel reports as an open fault on the supervisory circuit.

A digital message repeater (DMR) is built into all ANS systems unless ordered without the DMR. Up to 20 minutes of custom messages can be uploaded in the field with the use of a laptop and the *ANSCONFSOFT1* configuration software. In addition, the selection from eight available alarm tones, automatic message repeats, AC fault report delay, and connected equipment settings are all field-configurable.

The paging microphone is an integral component of the audio notification system. Removal of the microphone from the panel will cause a Trouble condition. This is reported locally, as well as through the fire alarm control panel.

All ANS panels include a 120 V, 60 Hz supply (standby batteries are required). Optionally, ANS panels can be powered with 24vdc from the fire alarm control panel or a booster power supply. Where speaker-strobes are used, strobe power is provided by the fire alarm control panel or a booster power supply.

# Typical Wiring

## ANS 25, 50, 100

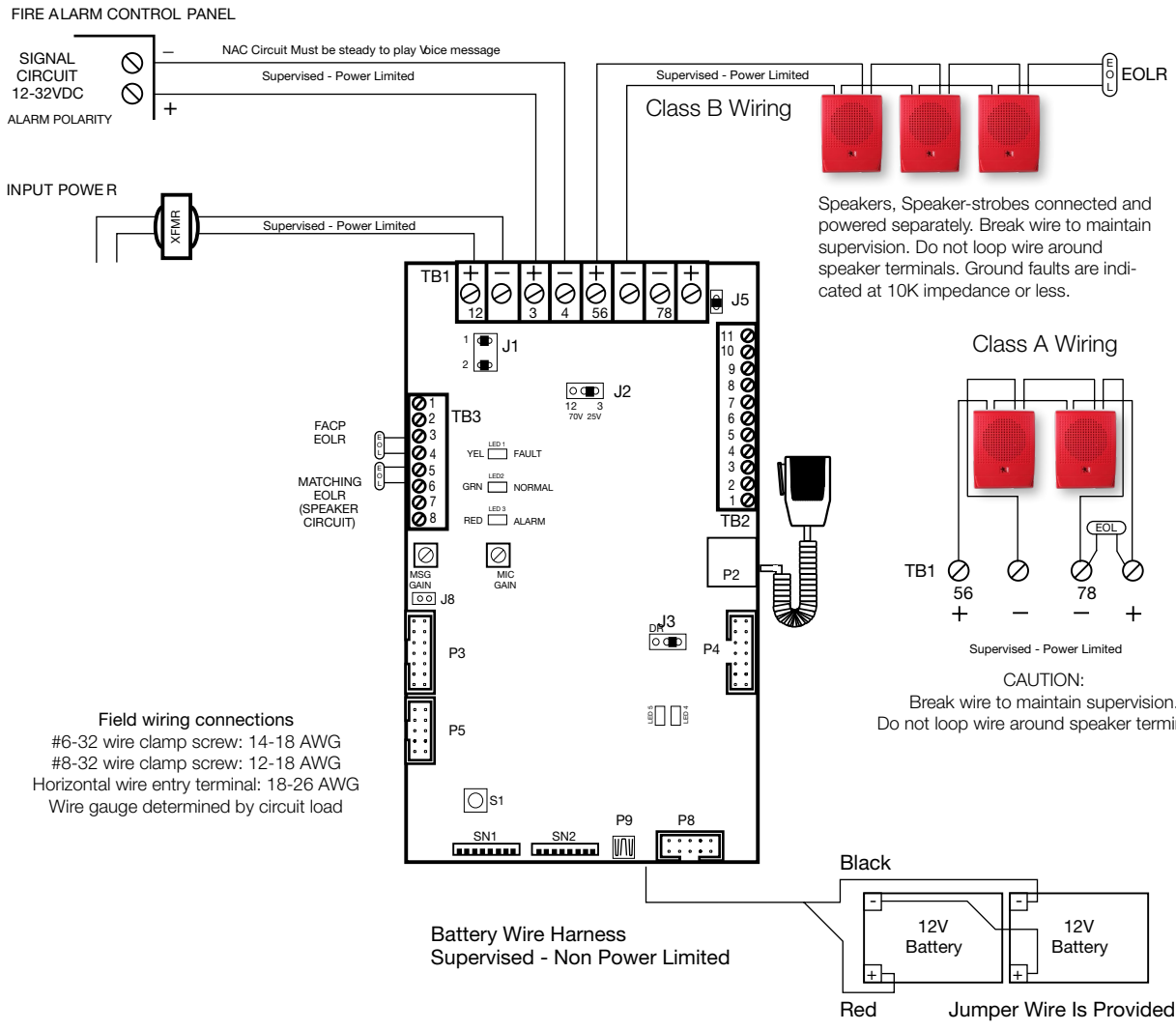

Speakers, Speaker-strobes connected and powered separately. Break wire to maintain supervision. Do not loop wire around speaker terminals. Ground faults are indicated at 10K impedance or less.

**CAUTION:**  
Break wire to maintain supervision.  
Do not loop wire around speaker terminals.

**Field wiring connections**  
#6-32 wire clamp screw: 14-18 AWG  
#8-32 wire clamp screw: 12-18 AWG  
Horizontal wire entry terminal: 18-26 AWG  
Wire gauge determined by circuit load

# Application Drawings

## Optional Supervisory Circuit

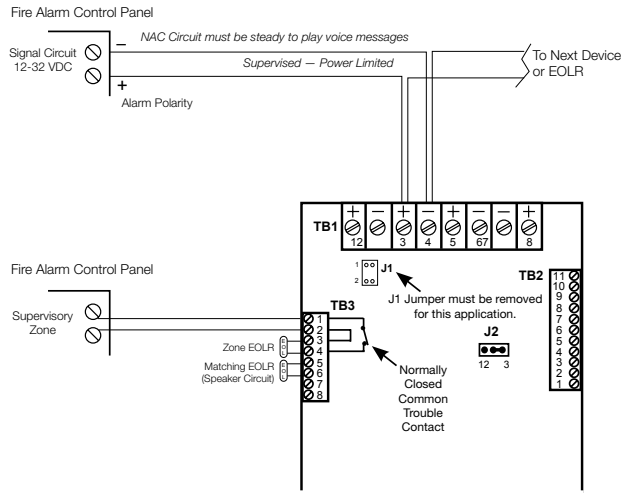

## Addressable System

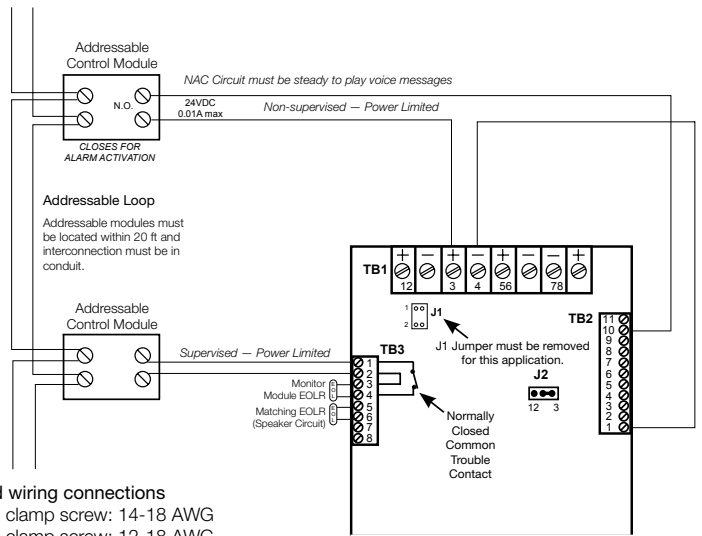

Field wiring connections  
 #6-32 wire clamp screw: 14-18 AWG  
 #8-32 wire clamp screw: 12-18 AWG  
 Horizontal wire entry terminal: 18-26 AWG  
 Wire gauge determined by circuit load

## Multiple Unit Connection

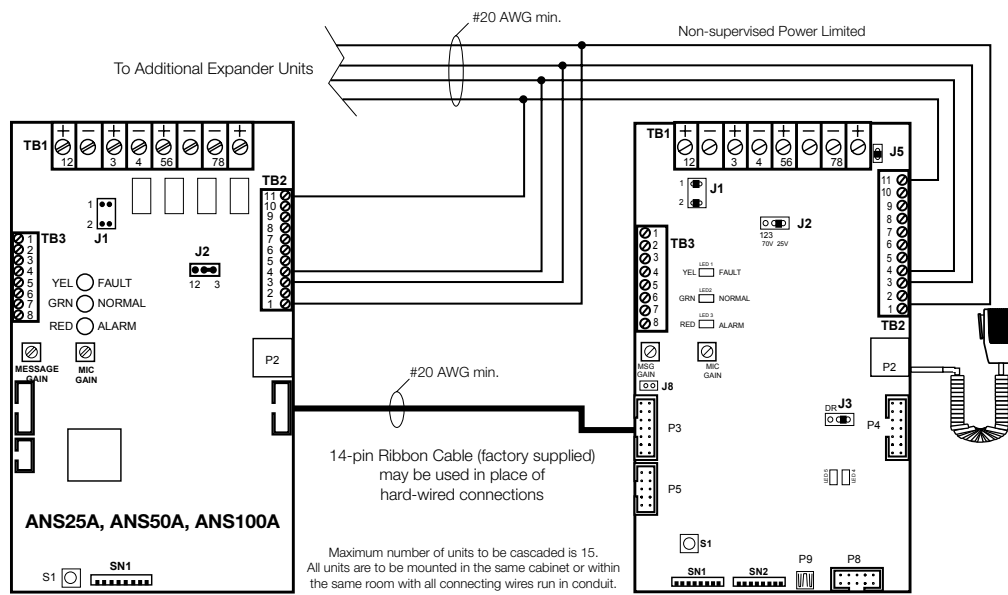

## Aux Audio Enable Connection

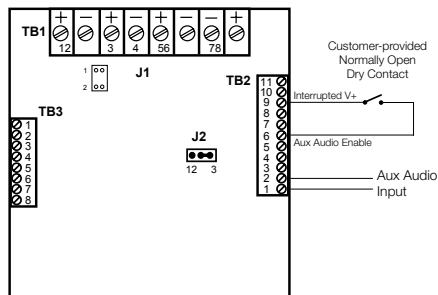

Field wiring connections  
 #6-32 wire clamp screw: 14-18 AWG  
 #8-32 wire clamp screw: 12-18 AWG  
 Horizontal wire entry terminal: 18-26 AWG  
 Wire gauge determined by circuit load

# Accessory Equipment

## Zone Splitter



The ANSZM4B2A Zone Splitter Module is used to enable the output of the ANS25, ANS50 or ANS100 to be split into multiple circuits for audio power distribution. The module accepts input from the ANS speaker output and utilizes output relays to distribute the power to separate circuits. The module may be cascaded to increase the number of circuits, and provides supervision of the individual circuits for either open or short conditions. Indicator LEDs display active or fault conditions for the individual circuits. A fault condition is reported to the ANS via the I2C communication port. The Zone Splitter Module may also be used with legacy ANS models, but in these cases supervision must employ TB2 Terminals 10 - 11 as a supervisory input.

If Manual control of the circuits is required, an ANSSW8 must be employed. Zones may then be selected manually by switches or through pull-down inputs. In the event of an alarm condition, the module defaults to an All-Call. All-Call feature may only be overridden if accompanying panel has zone control features.

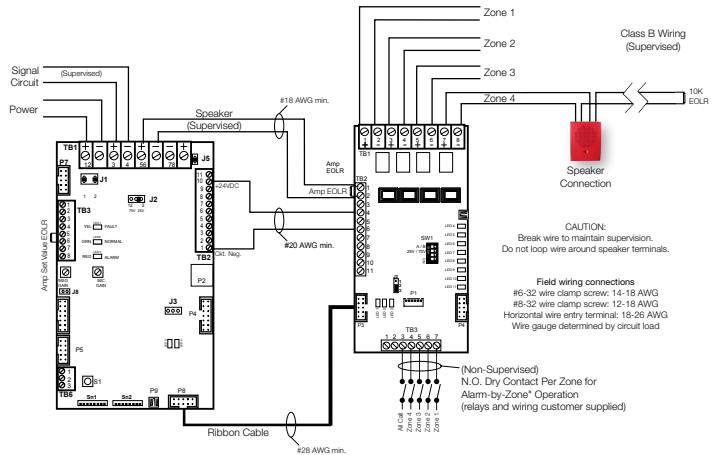

**ANSZM4B2A Zone Splitter Module**  
Typical Wiring

## Expander Panels and Modules



Audio Notification System expander panels and modules provide an easy and cost-effective way to increase the output power of ANS25, ANS50 or ANS100 voice evacuation systems.

Audio Notification System panels include an audio amplifier, temporal pattern alarm tone, power supply

and battery charger. They can be ordered with or without a paging microphone and/or digital message repeater.

Audio Notification System modules do not include cabinets, and are intended to be mounted in a UL Listed enclosure. They can be ordered with or without a paging microphone and or digital message repeater. Voice evacuation expanders may be ganged together in any combination to provide up to 2,000 Watts of audio power.

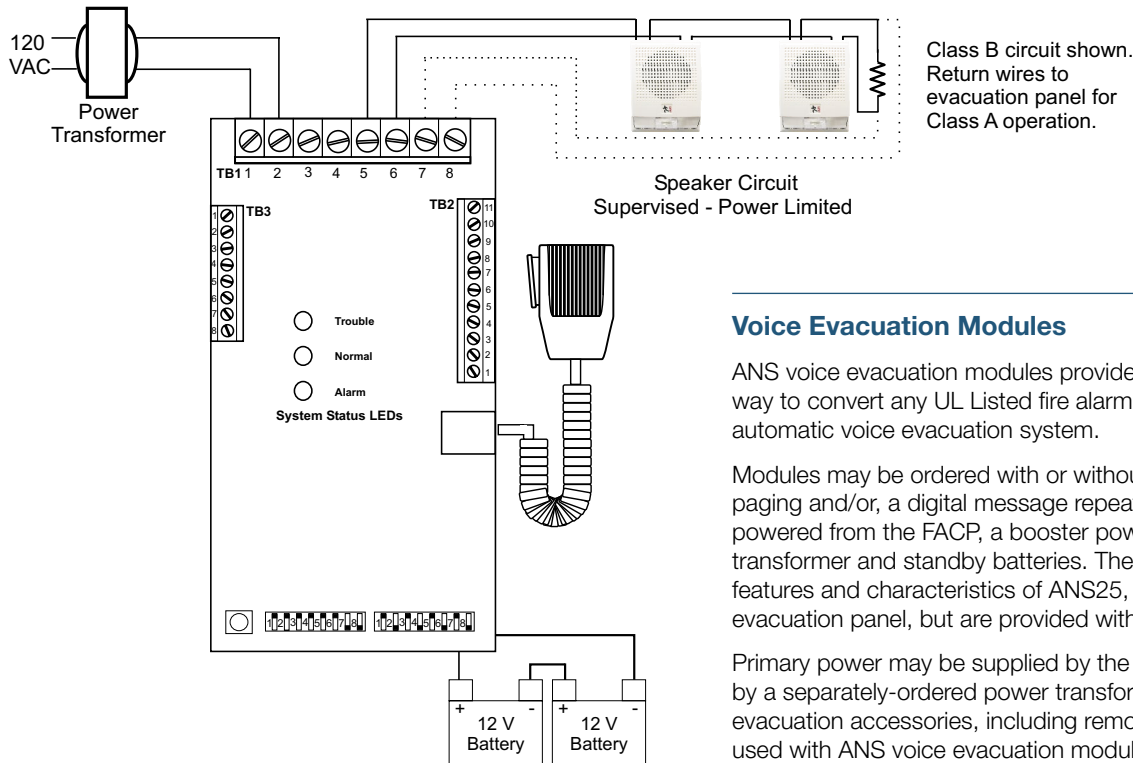

## Voice Evacuation Modules

ANS voice evacuation modules provide an easy and cost-effective way to convert any UL Listed fire alarm panel or system to an automatic voice evacuation system.

Modules may be ordered with or without a microphone for manual paging and/or, a digital message repeater (DMR). Modules can be powered from the FACP, a booster power supply or an optional transformer and standby batteries. They provide all the operational features and characteristics of ANS25, ANS50, or ANS100 voice evacuation panel, but are provided without the enclosure.

Primary power may be supplied by the fire alarm control panel or by a separately-ordered power transformer. Any of the ANS voice evacuation accessories, including remote microphones, may be used with ANS voice evacuation modules. Expander modules can also be added in any combination to provide up to 2,000 Watts of audio power in a single voice evacuation system.

# Accessory Equipment

## ANSSW8 Switch/LED Card



The ANSSW8 is an optional control/indication module that includes eight momentary contact switches and eight tri-color (green/red/amber) LEDs. Switches may be programmed for paging, emergency message activation, or control functions. When used in conjunction with the ANSZM4B2A Zone Splitter, the ANSSW8 may be programmed for zone paging. LEDs for switches assigned to page zones will indicate steady red for *Page* and flashing red for *Alarm*. An emergency message broadcast to any zone will indicate green. The zone LED will indicate amber if the associated speaker zone is in fault condition.

Switches programmed for messages indicate Green when selected. Only one message is active at a time. If a higher priority message is activated while a message is playing, its associated LED will go off and the higher priority message LED will indicate. A fire alarm condition will override all other messages in the queue and the associated fire alarm message will be broadcast immediately.

Switches may alternately be programmed for control functions. On a switch activation, a corresponding point on an ANSXM8 Output Card will follow. Switch LEDs indicate red on activation.

## ANSDC8 Intelligent Input Interface Card



The ANSDC8 is an intelligent input interface card with eight input points and eight corresponding red input LEDs. The ANSDC8 accepts external normally-open dry contacts. Inputs may be programmed for message activation or control functions. On activation of an input point the corresponding input LED turns on.

## ANSXM8 Intelligent Output Interface Card



The ANSXM8 is an intelligent output interface card with eight output points and eight red LEDs. Outputs are solid-state normally-open dry contacts rated at 30 mA max @ 0 - 24 V. They may be field configured as normally-open dry contacts, or as separate voltage drive points. When used as drive points, each output can be tied to a specified voltage from zero to 24 volts, and feed the designated voltage as a drive point. Outputs 1 through 4 and Outputs 5 through 8 may linked to the same or different voltage references. Outputs may be programmed to follow a message activation, a page, or a control function. On activation the corresponding input LED will indicate.

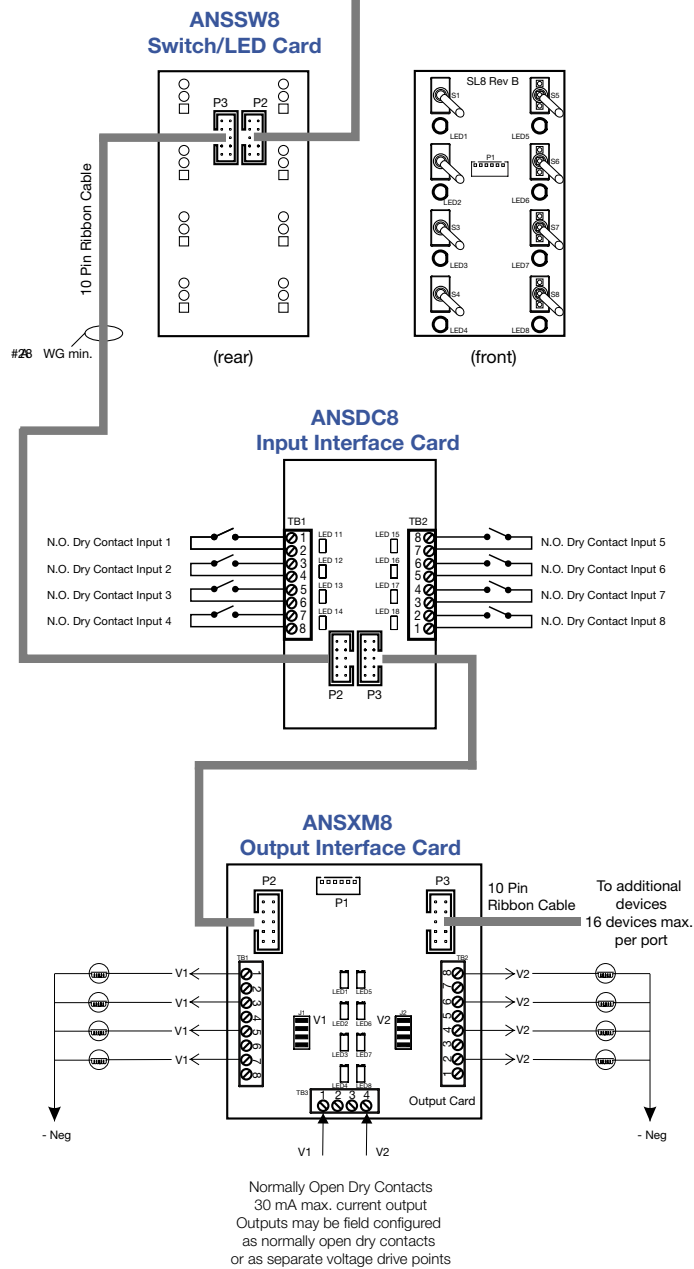
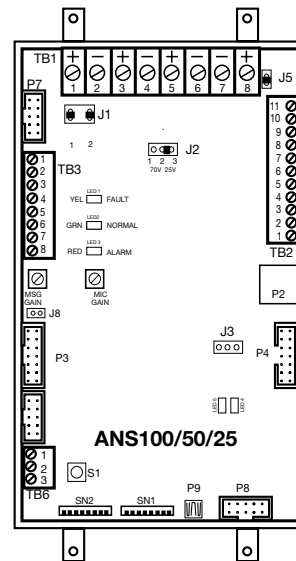

# Accessory Equipment

## Remote Microphone Panel



The ANSREM is a supervised remote microphone for use with the ANS voice evacuation system. The microphone provides crystal-clear live voice messages over the system speakers.

Up to five ANSREM panels may be connected to a single ANS-REMSUP supervisory card. This provides supervision of the wires to the ANSREM and supports wiring distances of up to 5,000 feet (1,524 meters).

The ANSREM is housed in an attractive surface or semi-flush mounted enclosure, with a hinged locking door. It features dead-front construction, a microphone with a "Press-to-Talk" button, and discreet LEDs that indicate In-Use and Fault status.

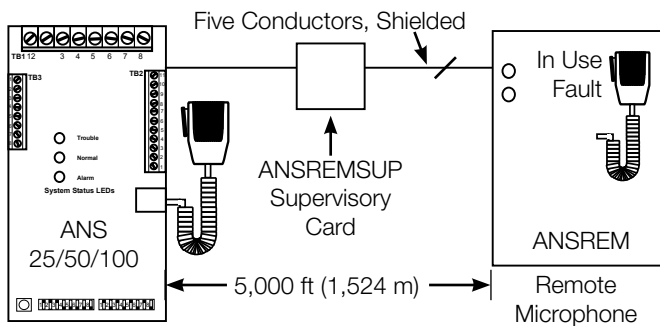

Remote Microphone Panel Dimensions:  
8" H x 10" W x 3" D (203 mm x 254 mm x 76 mm)

## Standard Message

This message is included with the ANS 25/50/100.

(Female Voice) *"Attention Please, there has been a report of an emergency. Proceed calmly to the nearest exit and leave the building immediately. Do not use the elevators, use stairwells where necessary. All handicapped occupants shall use the building evacuation plan."*

## Backup Amplifier Switching Card

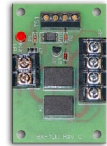

The ANSBKUP switching card continually monitors the primary amplifier for signs of failure. Should the amplifier fail, the ANSBKUP automatically activates a backup amplifier. A single amplifier can be used to back up one or more amplifiers of equal or lesser wattage. One ANSBKUP is required for each amplifier being backed up. The backup amplifier does not require its own microphone and digital message repeater unless a fully redundant voice evacuation system is required.

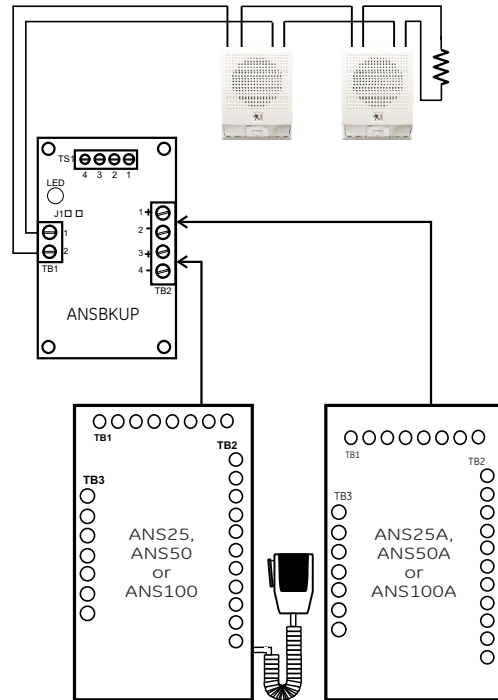

Note: Back-up amplifier does not require microphone or DMR.

# Engineering Specification

The voice evacuation system shall be EDWARDS ANS Series or approved equal. The voice evacuation system shall provide <25><50><100> Watts signal power and <25><50><100> Watts voice power, and shall be UL Listed.

All speaker circuits shall be field selectable for 25 or 70 Vrms operation and shall be power limited.vav

The voice evacuation system shall be microprocessor based, and shall contain an integral microphone, <25><50><100> Watt audio amplifier, tone generator, digital message repeater, 120 VAC power supply, and battery charger.

The voice evacuation message/signal shall be broadcast until the Fire Alarm Control Panel (FACP) is reset, or until fire emergency personnel interrupt the broadcast with a manual page. On reset system shall automatically return to standby (normal operating) condition.

A secondary message shall be provided that can be triggered by the closure of a contact from either the FACP or from any normally open contact device.

Remote paging microphone(s) will be supported by the system through a supervised circuit. Remote microphone(s) may be mounted up to 5,000 ft. (1,524 m) away from the voice evacuation panel.

## Specifications

Model		ANS25	ANS50	ANS100
Output power		25 W	50 W	100 W
Output voltage		25 or 70 Vrms selectable		
Output protection		Power-limited, open and short circuit protected		
Input voltage		120 Vac at 60 Hz		
Input current		0.8 A @ 120 Vac	0.5 A @ 120 Vac	1.0 A @ 120 Vac
Optional 24 Vdc input <sup>1</sup>	Standby	0.60 A	0.60 A	0.60 A
	Alarm	1.00 A	1.00 A	2.60 A
	Sine	2.90 A	3.40 A	6.50 A
Frequency response		800 - 2800 Hz	400 - 4000 Hz	
Dimensions		Rough-in: 14.5 x 18 x 4" (368 x 457 x 102 mm) Finished Door: 16.25 x 19.5" (413 x 495 mm)		
Battery Type		Two 12 V Gel Cell in series		
Battery size	Minimum	24 V, 7 Ah	24 V, 7 Ah	24 V, 7 Ah
	Maximum	24 V, 18 Ah	24 V, 18 Ah	24 V, 24 Ah
Battery Standby Operating Time		24-60 Hours in Standby 15 minutes in Alarm		
Battery Charging Current		800 mA		
Battery Input current		Full speaker load, no aux load:		
	Standby Alarm	0.18 A 1.10 A	0.15 A 0.80 A	0.16 A 0.60 A
Battery Input Current		Full speaker load, full aux load of 0.5 A:		
	Standby Alarm	1.10 A 2.50 A	1.00 A 1.10 A	1.10 A 2.00 A

<sup>1</sup> **Input current** measurements are determined using test conditions specified in UL 1711. **Sine** represents measurements made while the unit produces a continuous, undistorted sine wave of 1 kHz into the rated load of 25, 50, or 100 W at the rated output voltage. **Alarm** is the average current the unit experiences delivering an alarm signal, temporal whoop, to the rated load. **Standby** is the current draw of the unit with all normal power on and auxiliary terminals fully loaded. **Battery standby** is the current draw from the batteries on loss of power in an otherwise normal standby state.





LIFE SAFETY & INCIDENT MANAGEMENT

**Contact us**

Phone: 800-655-4497 (Option 4)  
 Email: [edwards.fire@carrier.com](mailto:edwards.fire@carrier.com)  
 Website: [edwardsfiresafety.com](http://edwardsfiresafety.com)

8985 Town Center Pkwy  
 Bradenton, FL 34202

© 2020 Carrier  
 All rights reserved.

## Ordering Information

Part Number	Description	Wt. lb (kg)
<b>Audio Notification Panels</b>		
<i>Audio Notification Panels include DMR, Power Supply &amp; Battery Charger, Standard Message, Microphone, and Cabinet.</i>		
ANS100MDG2	100 Watt Audio Notification Panel. Gray Cabinet.	32 (14.5)
ANS100MDR2	100 Watt Audio Notification Panel. Red Cabinet.	32 (14.5)
ANS25MDG2	25 Watt Audio Notification Panel. Gray Cabinet.	29 (13.2)
ANS25MDR2	25 Watt Audio Notification Panel. Red Cabinet.	29 (13.2)
ANS50MDG2	50 Watt Audio Notification Panel. Gray Cabinet.	32 (14.5)
ANS50MDR2	50 Watt Audio Notification Panel. Red Cabinet.	32 (14.5)
<b>Expander Panels</b>		
ANS100XG	100 Watt Audio Expander Panel. Gray Cabinet.	32 (14.5)
ANS100XR	100 Watt Audio Expander Panel. Red Cabinet.	32 (14.5)
ANS25XG	25 Watt Audio Expander Panel. Gray Cabinet.	29 (13.2)
ANS25XR	25 Watt Audio Expander Panel. Red Cabinet.	29 (13.2)
ANS50XG	50 Watt Audio Expander Panel. Gray Cabinet.	32 (14.5)
ANS50XR	50 Watt Audio Expander Panel. Red Cabinet.	32 (14.5)
<i>Panels include power supply and battery charger".</i>		
<b>Zone Splitters</b>		
ANSZM4B2A	Zone Module. 4 Class B or 2 Class A circuits.	
<b>Remote Microphones</b>		
ANSREMG	Remote microphone. Requires ANSREMSUP card in ANS panel. Gray surface/semi-flush cabinet. Supervised.	8 (3.6)
ANSREMR	Remote microphone. Requires ANSREMSUP card in ANS panel. Red surface/semi-flush cabinet. Supervised.	8 (3.6)
ANSREMSUP	Remote microphone supervisory card, one per system. Supervises up to 5 remote microphones.	1 (0.5)
<b>Backup Amplifier Modules</b>		
ANSBKUP	Backup amplifier switching module.	1 (0.5)
<b>Modules</b>		
ANS100A	100 Watt expander module.	5 (2.3)
ANS100AMD2	100 Watt audio notification module with DMR and microphone.	5 (2.3)
ANS25A	25 Watt expander module.	5 (2.3)
ANS25AMD2	25 Watt audio notification module with DMR and microphone.	5 (2.3)
ANS50A	50 Watt expander module.	5 (2.3)
ANS50AMD2	50 Watt audio notification module with DMR and microphone.	5 (2.3)
ANSDC8	8 dry-contact input/LED module.	
ANSSW8	8 position switch/LED module.	
ANSXM8	8 transistor output/LED module.	
<b>Custom Messages (for ANS1 Series only)</b>		
ANSDMRALT	Alternate prerecorded DMR message PROM from library.	
ANSDMRCUSTOM	Custom recorded message PROM. Call customer service for quotation and availability.	

LIFE SAFETY &amp; INCIDENT MANAGEMENT

# Remote Booster Power Supplies

**BPS6A, BPS10A**

## Overview

The Booster Power Supply (BPS) is a UL 864, 9th Edition listed power supply. It is a 24 Vdc filtered-regulated, and supervised unit that can easily be configured to provide additional notification appliance circuits (NACs) or auxiliary power for Mass Notification/Emergency Communication (MNEC), as well as life safety, security, and access control applications.

The BPS contains the circuitry to monitor and charge internal or external batteries. Its steel enclosure has room for up to two 10 ampere-hour batteries. For access control-only applications, the BPS can support batteries totaling up to 65 ampere-hours in an external enclosure. The BPS has four Class B (convertible to two Class A) NACs. These can be activated in one or two groups from the BPS's unique dual input circuits.

The BPS is available in 6.5 or 10 ampere models. Each output circuit has a capacity of three amperes; total current draw cannot exceed the unit's rating.

The BPS meets current UL requirements and is listed under the following standards:

Standard (CCN)	Description
UL864 9th ed.ition (UOXX)	Fire Alarm Systems
UL636 (ANET, UEHX7)	Holdup Alarm Units and Systems
UL609 (AOTX, AOTX7)	Local Burglar Alarm Units and Systems
UL294 (ALVY, UEHX7)	Access Control Systems
UL365 (APAW, APAW7)	Police Station Connected Burglar Alarm Units and Systems
UL1076 (APOU, APOU7)	Proprietary Burglar Alarm System Units
UL1610 (AMCX)	Central Station Alarm Unit
ULC-S527 (UOXXC)	Control Units, Fire Alarm (Canada)
ULC-S303 (AOTX7)	Local Burglar Alarm Units and Systems (Canada)
C22.2 No. 205	Signaling Equipment (Canada)

## Standard Features

- Allows for reliable filtered and regulated power to be installed where needed
- Cost effective system expansion
- Provides for Genesis and Enhanced Integrity notification appliance synchronization
- Supports coded output operation
- Self-restoring overcurrent protection
- Multiple signal rates
- Can be cascaded or controlled independently
- Easy field configuration
- On-board diagnostic LEDs identify wiring or internal faults
- Standard EDWARDS keyed lockable steel cabinet with removable door
- 110 and 230 Vac models available
- Accommodates 18 to 12 AWG wire sizes
- Optional tamper switch
- Dual battery charging rates
- Optional earthquake hardening: OSHPD seismic pre-approval for component Importance Factor 1.5

## Application

The BPS provides additional power and circuits for notification appliances and other 24 Vdc loads. It is listed for indoor dry locations and can easily be installed where needed.

Fault conditions are indicated on the on-board diagnostic LEDs, opening the BPS input sense circuit and the trouble relay (if programmed). While this provides indication to the host system, the BPS can still be activated upon command. A separate AC Fail contact is available on the BPS circuit board, which can be programmed for trouble or AC Fail. There are seven on-board diagnostic LEDs: one for each NAC fault, one for battery fault, one for ground fault, and one for AC power.

The unique dual-input activation circuits of the BPS can be activated by any voltage from 6 to 45 VDC (filtered-regulated) or 11 to 33 Vdc (full-wave rectified, unfiltered). The first input circuit can be configured to activate 1-4 of the four possible outputs. The second input circuit can be configured to control circuits 3 and 4. When outputs are configured for auxiliary operation, these circuits can be configured to stay on or automatically deactivate 30 seconds after AC power is lost. This feature makes these circuits ideal for door holder applications. The BPS also has a separate 200 mA 24 Vdc output that can be used to power internal activation modules.

BPS NACs can be configured for a 3-3-3 temporal or continuous output. California temporal rate outputs are also available on certain models. This makes the BPS ideal for applications requiring signaling rates that are not available from the main system.

In addition to the internally generated signal rates, the BPS can also be configured to follow the coded signal rate of the main system NACs. This allows for the seamless expansion of existing NACs.

The BPS enclosure has mounting brackets for up to three Signature modules to the right of the circuit board.

## Engineering Specification

Supply, where needed, EDWARDS BPS Series Booster Power Supplies (BPS) that are interconnected to and supervised by the main system. The BPS shall function as a stand-alone auxiliary power supply with its own fully-supervised battery compliment. The BPS battery compliment shall be sized to match the requirements of the main system. The BPS shall be capable of supervising and charging batteries having the capacity of 24 ampere-hours for Mass Notification/Emergency Communication (MNEC), life safety and security applications, and the capacity of 65 ampere-hours for access control applications.

<<The BPS shall be capable of installation for a seismic component Importance Factor of 1.5.>> The BPS shall provide a minimum of four independent, fully supervised Class B circuits that can be field configurable for notification appliance circuits or auxiliary 24 Vdc power circuits. BPS NACs shall be convertible to a minimum of two Class A NACs. Each BPS output circuit shall be rated at 3 amperes at 24 Vdc. Each output circuit shall be provided with automatically restoring overcurrent protection. The BPS shall be operable from the main system NAC and/or EDWARDS Signature Series control modules. BPS NACs shall be configurable for continuous, 3-3-3 temporal or optionally, California rate. Fault conditions on the BPS shall not impede operation of main system NAC. The BPS shall be provided with ground fault detection circuitry and a separate AC fail relay.

## Dimensions

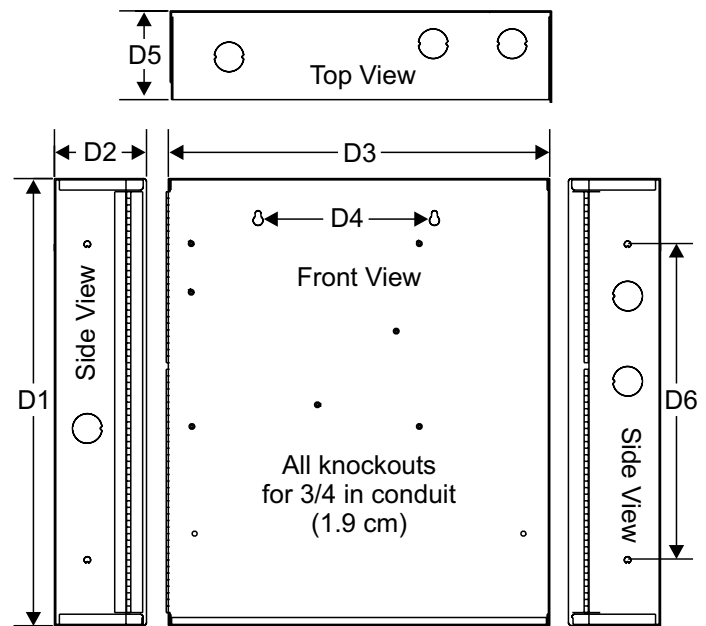

D1	D2	D3	D4	D5	D6
17.0 in (43.2 cm)	3.5 in (8.9 cm)	13.0 in (33.0 cm)	6.5 in (16.5 cm)	3.375 in (8.6 cm)	12.0 in (30.4 cm)

## Wire routing

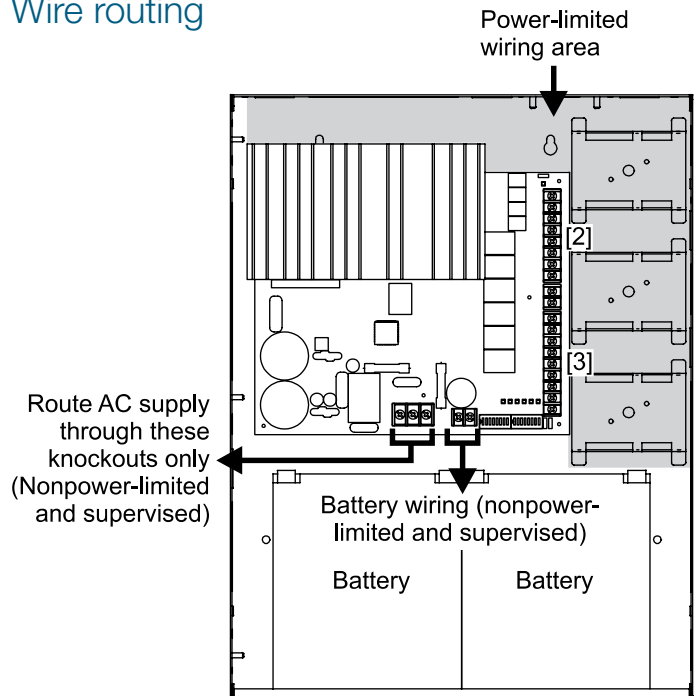

### Notes

1. Maintain 1/4-inch (6 mm) spacing between power-limited and nonpower-limited wiring or use type FPL, FPLR, or FPLP cable per NEC.
2. Power-limited and supervised when not configured as auxiliary power. Non-supervised when configured as auxiliary power.
3. Source must be power-limited. Source determines supervision.
4. When using larger batteries, make sure to position the battery terminals towards the door.

# Typical Wiring

Single or cascaded booster anywhere on a notification appliance circuit

Existing NAC end-of-line resistors are not required to be installed at the booster's terminals. This allows multiple boosters to be driven from a single NAC circuit without the need for special configurations.

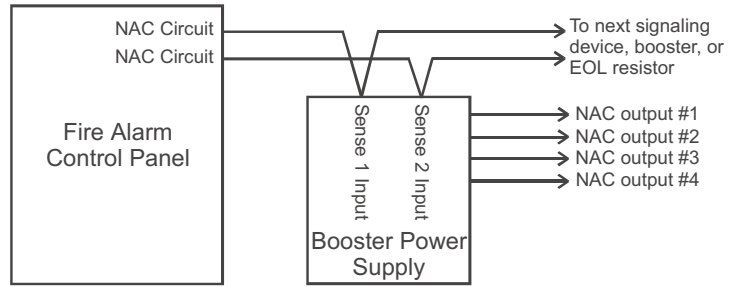

## Configuring the Booster for AC Power Fail delay operation\*

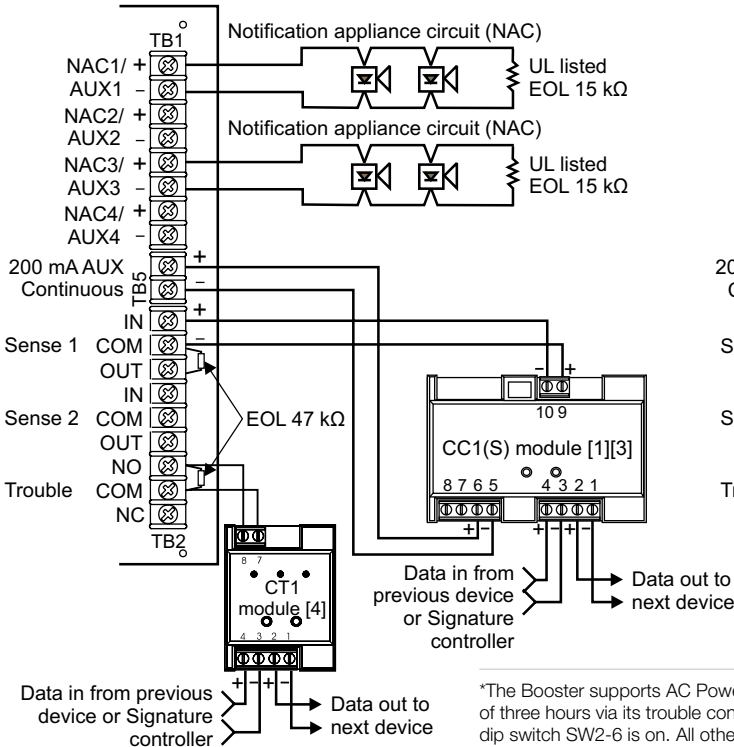

\*The Booster supports AC Power fail delay of three hours via its trouble contact when dip switch SW2-6 is on. All other troubles are reported to supervising module or panel without delay via Sense inputs.

## Multiple CC1(S) modules using the BPS's sense inputs

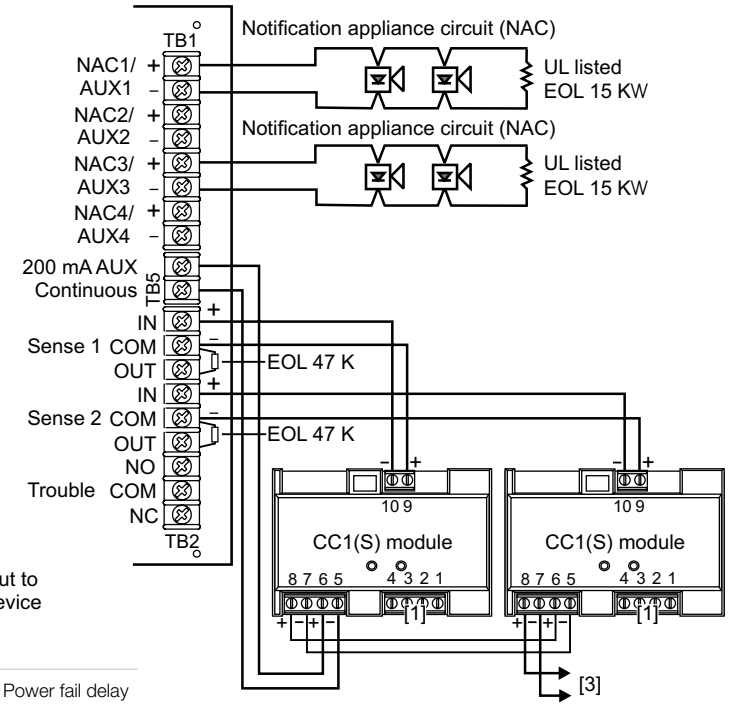

## Security and access

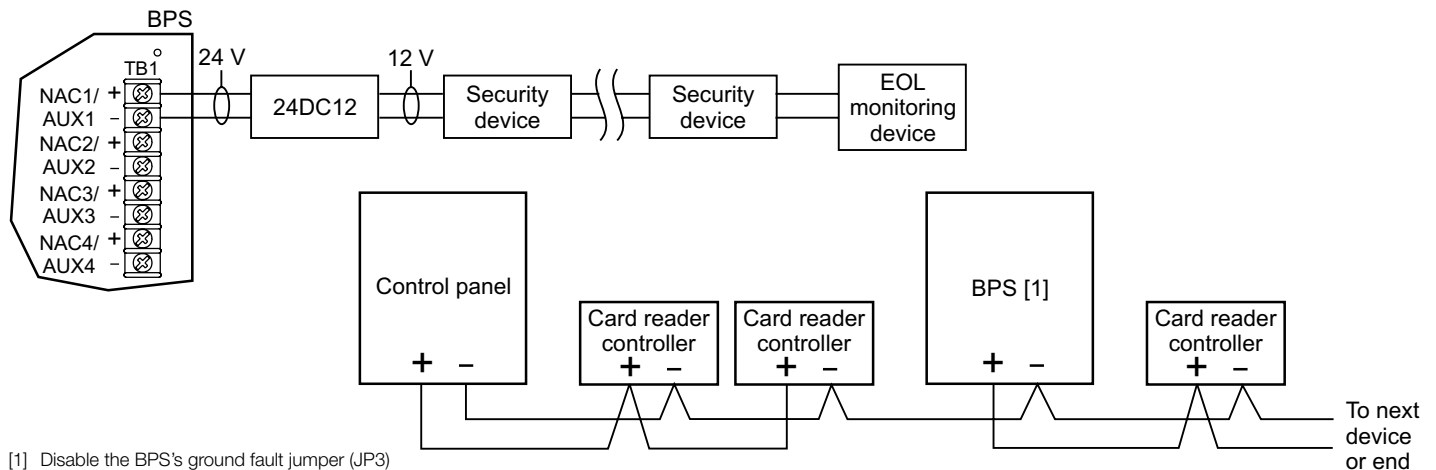

[1] Disable the BPS's ground fault jumper (JP3)



LIFE SAFETY & INCIDENT MANAGEMENT

**Contact us**

Phone: 800-655-4497 (Option 4)  
 Email: [edwards.fire@carrier.com](mailto:edwards.fire@carrier.com)  
 Website: [edwardsfiresafety.com](http://edwardsfiresafety.com)

8985 Town Center Pkwy  
 Bradenton, FL 34202

© 2020 Carrier  
 All rights reserved.

## Specifications

Model	6.5 amp Booster	10 amp Booster
AC Line Voltage	120VAC or 220-240VAC 50/60Hz 390 watts	120VAC or 220-240VAC 50/60Hz 580 watts
Notification Appliance Circuit Ratings	3.0A max. per circuit @ 24Vdc nominal 6.5A max total all NACs	3.0A max. per circuit @ 24Vdc nominal 10A max total all NACs
Trouble Relay	2 Amps @ 30Vdc	
Auxiliary Outputs	Four configurable outputs replace NACs 1, 2, 3 or 4. as auxiliary outputs and 200 mA dedicated auxiliary. (See note 2.)	
Input Current (from an existing NAC)	3mA @ 12Vdc, 6mA @ 24Vdc	
Booster Internal Supervisory Current	70mA + 35 mA for each circuit set to AUX	
Booster Internal Alarm Current	270mA	
Signature Mounting Space	Accommodates three two-gang modules.	
Maximum Battery Size	10 Amp Hours (2 of 12V10A) in cabinet up to 24 Amp hours with external battery cabinet for fire and security applications; up to 65 Amp hours for access control applications in external battery box.	
Terminal Wire Gauge	18-12 AWG	
Relative Humidity	0 to 93% non condensing @ 32°C	
Temperature Rating	32° to 120°F (0° to 49°C)	
NAC Wiring Styles	Class A or Class B	
Output Signal Rates	Continuous, California rate, 3-3-3 temporal, or follow installed panel's NAC. (See note 1.)	
Ground Fault Detection	Enable or Disable via jumper	
Agency Listings	UL, ULC, CSFM	

1. Model BPS\*CAA provides selection for California rate, in place of temporal.
2. Maximum of 8 Amps can be used for auxiliary output.

## Ordering Information

Catalog Number	Description	Shipping Wt. lb (kg)
<b>BPS6A</b>	<b>6.5 Amp Booster Power Supply</b>	13 ( 5.9)
BPS6AC	6.5 Amp Booster Power Supply (ULC)	13 ( 5.9)
BPS6A/230	6.5 Amp Booster Power Supply (220V)	13 ( 5.9)
BPS6CAA	6.5 Amp Booster Power Supply with California rate	13 ( 5.9)
BPS10A	10 Amp Booster Power Supply	13 ( 5.9)
BPS10AC	10 Amp Booster Power Supply (ULC)	13 ( 5.9)
BPS10A/230	10 Amp Booster Power Supply (220V)	13 ( 5.9)
BPS10CAA	10 Amp Booster Power Supply with California rate	13 ( 5.9)

1. Requires installation of separate battery cabinet.
2. BPS supports batteries greater than 24 Amp hours for access control applications only.
3. For earthquake anchorage, including detailed mounting weights and center of gravity detail, refer to Seismic Application Guide 3101676. Approval of panel anchorage to site structure may require local AHJ, structural or civil engineer review.

### Related Equipment

12V6A5	7.2 Amp Hour Battery, two required	3.4 (1.6)
12V10A	10 Amp Hour Battery, two required	9.5 (4.3)
3-TAMP	Tamper switch	
BC-1EQ	Seismic Kit for BC-1. Order BC-1 separately. See note 3.	
BPSEQ	Seismic kit for BPS6A or BPS10 Booster Power Supplies. See note 3	
BC-1	Battery Cabinet (up to 2 - 40 Amp Hour Batteries)	58 (26.4)
BC-2	Battery Cabinet (up to 2 - 17 Amp Hour Batteries)	19 (8.6)
12V17A	18 Amp Hour Battery, two required (see note 1)	13 ( 5.9)
12V24A	24 Amp Hour Battery, two required (see note 1)	20 (9.07)
12V40A	40 Amp Hour Battery, two required (see notes 1, 2)	32 (14.5)
12V50A	50 Amp Hour Battery, two required (see notes 1, 2)	40 (18.14)
12V65A	65 Amp Hour Battery, two required (see notes 1, 2)	49 (22.2)

LIFE SAFETY &amp; INCIDENT MANAGEMENT

# Sealed Lead-Acid Batteries



## Overview

Rechargeable sealed lead-acid batteries are ideal for use as a secondary (standby) power source as defined by NFPA 72. Their low maintenance and high energy density make them ideal for fire alarm signaling applications.

## Standard Features

- Rechargeable
- Non-spillable
- Non-hazardous
- Low maintenance
- High energy density

## Application

When multiple power supplies are provided, each power supply's battery requirements should be calculated individually. Consult the specific system manual to determine battery capacity requirements.

### Safety Information

Due to a battery's low internal resistance and high power density, high levels of short circuit current can develop across battery terminals. Put on protective eye covering and remove all jewelry before working on batteries. Do not rest tools or cables on the battery, and only use insulated tools. Follow all manufacturers installation instructions and diagrams when installing or maintaining batteries.



LIFE SAFETY & INCIDENT MANAGEMENT

**Contact us**

Phone: 800-655-4497 (Option 4)  
Email: [edwards.fire@carrier.com](mailto:edwards.fire@carrier.com)  
Website: [edwardsfiresafety.com](http://edwardsfiresafety.com)

8985 Town Center Pkwy  
Bradenton, FL 34202

© 2020 Carrier  
All rights reserved.

## Specifications

Case Material	ABS Thermoplastic
Regulatory Information	DOT Class 60, Batteries, non-hazardous, non-spillable
Operating Environment	32° F to 120° F (0° C to 49° C) 0 to 93% RH, Non-condensing

## Ordering Information

Catalog Number	Description	Shipping Weight, lb (kg)
12V4A	4.5 Ah Sealed Lead Acid Battery - 12 Vdc	5 (2.27)
<b>12V6A5</b>	<b>7.2 Ah Sealed Lead Acid Battery - 12 Vdc</b>	<b>6 (2.72)</b>
6V8A	8 Ah Sealed Lead Acid Battery - 6 Vdc	4 (1.81)
6V10A	12 Ah Sealed Lead Acid Battery - 6 Vdc	5 (2.27)
12V10A	11 Ah Sealed Lead Acid Battery - 12 Vdc	10 (4.45)
12V17A	18 Ah Sealed Lead Acid Battery - 12 Vdc	13 (5.90)
12V24A	26 Ah Sealed Lead Acid Battery - 12 Vdc	20 (9.07)
12V40A	40 Ah Sealed Lead Acid Battery - 12 Vdc	32 (14.51)
12V50A	50 Ah Sealed Lead Acid Battery - 12 Vdc	40 (18.14)
12V65A	65 Ah Sealed Lead Acid Battery - 12 Vdc	49 (22.23)



LIFE SAFETY &amp; INCIDENT MANAGEMENT

# Intelligent Smoke Detector

**SIGA-OSD**Helps Reduce Cooking Nuisance Alarms  
UL 268 7th Ed.7272-1657:  
0511

## Overview

The Signature Optica Series SIGA-OSD smoke detector brings advanced optical (photoelectric) technology to a practical design that increases efficiency, saves installation time, cuts costs, and extends life safety and property protection capabilities. Continuous self-diagnostics ensure reliability over the long-haul, while environmental compensation helps reduce maintenance costs.

Like all Signature Optica Series detectors, the SIGA-OSD is an intelligent device that gathers analog information from multiple optical sensors, converting this data into digital signals. Utilizing dual optical wavelengths combined with multiple detection angles, the SIGA-OSD differentiates particles that are not representative of actual smoke. Particle data is input into digital filters which feed a series of ratios removing signal patterns that are typical of nuisance sources, thus reducing unwanted alarms. To make an alarm decision, the detector's on-board microprocessor measures and analyzes all optical sensor readings and compares this information to preprogrammed settings.

## Standard Features

- Multi-criteria optical smoke sensing technology
- Wide 0.5 to 4.36 %/ft. (1.6 to 13.6 %/m) smoke obscuration
- Uses Existing Wiring
- Integrated nuisance rejection reducing unwanted alarms from general cooking particulates
- Listed to UL 268 7th edition
- Automatic Device Mapping
- Up To 250 Total Signature Addresses Per Loop
- Two Levels of Environmental Compensation
- Two Levels of Dirty Detector Warning
- Twenty Pre-Alarm Settings
- Five Sensitivity Settings
- Non-Volatile Memory
- Electronic Addressing
- Automatic Day/Night Sensitivity Adjustment
- Bicolor (Green/Red) Status LED
- Standard, Relay, Fault Isolator, and Audible Mounting Bases
- Sensor Markings Provide Easy Testing Identification

Note: Some features described here may not be supported by all control systems. Check your control panel's Installation and Operation Guide for details.



## Application

The SIGA-OSD detects particles from a wide range of combustion sources and will trigger an alarm when smoke density in the chamber reaches preprogrammed level. Thanks to its high-performance reflective response technology, the smoke sensor responds quickly and reliably to a wide range of fire types, including both fast and slow burning fires fueled by combustibles typically found in modern multi-use buildings.

## Compatibility

The SIGA-OSD detector is compatible only with control panels using a Signature Loop controller.

## Installation

Signature Series detectors mount to North American 1-gang boxes, 3-1/2 inch or 4 inch octagon boxes, and to 4 inch square electrical boxes 1-1/2 inches (38 mm) deep. They mount to European BESA and 1-gang boxes with 60.3 mm fixing centers. See mounting base installation and wiring for more information.

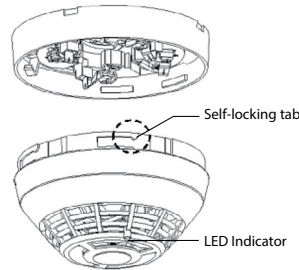

## Sensing and reporting technology

The microprocessor in each detector provides additional benefits – Self-diagnostics and History Log, Automatic Device Mapping, and Fast, Stable Communication.

**Self-diagnostics and History Log** - Each Signature Series detector constantly runs self-checks to provide important maintenance information. The results of the self-check are automatically updated and permanently stored in the detector's non-volatile memory

**Automatic Device Mapping** - The loop controller learns where each device's serial number address is installed relative to other devices on the circuit. The mapping feature provides supervision of each device's installed location to prevent a detector from being reinstalled (after cleaning, etc.) in a different location from where it was originally.

**Fast Stable Communication** - On-board intelligence means less information needs to be sent between the detector and the loop controller. Other than regular supervisory polling response, the detector only needs to communicate with the loop controller when it has something new to report.

## Testing & Maintenance

Each detector automatically identifies when it is dirty or defective and causes a "dirty detector" message. The detector's sensitivity measurement can also be transmitted to the loop controller. A sensitivity report may be printed to satisfy NFPA sensitivity measurements, which must be conducted at the end of the first year and every two years thereafter.

The user-friendly maintenance program shows the current state of each detector and other pertinent messages. Single detectors may be turned off temporarily from the control panel. Availability of maintenance features is dependent on the fire alarm system used.

## Accessories

**Detector mounting bases** have wiring terminals that are accessible from the "room-side" after mounting the base to the electrical box. The bases mount to North American 1-gang boxes and to 3½ inch or 4 inch octagon boxes, 1½ inches (38 mm) deep. They also mount to European BESA and 1-gang boxes with 60.3 mm fixing centers. The SIGA-SB4, SIGA-RB4, and SIGA-IB4 mount to North American 4 inch sq. electrical boxes in addition to the above boxes. They include the SIGA-TS4 Trim Skirt, which is used to cover the "mounting ears" on the base. The SIGA-AB4G mounts to a 4 inch square box only.

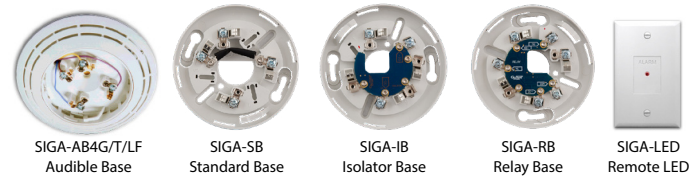

**Remote LED SIGA-LED** - The remote LED connects to the SIGA-SB or SIGA-SB4 Standard Base only. It features a North American size 1-gang plastic faceplate with a white finish and red alarm LED.

**SIGA-TS4 Trim Skirt** - Supplied with 4 inch bases, it can also be ordered separately to use with the other bases to help hide surface imperfections not covered by the smaller bases.

**Sounder Bases** - Signature Series sounder bases are designed for use where localized or group alarm signaling is required.

- SIGA-AB4G bases provide sounder capability to Signature Series to heat and smoke detectors. They are not intended for use with combination carbon monoxide detectors in Fire-plus-CO mode.
- SIGA-AB4GT bases provide sounder capability to Signature Series smoke and heat detectors, as well as carbon monoxide detectors when used with a SIGA-TCDR Temporal Pattern Generator.
- SIGA-AB4G-LF bases provide 520 Hz low frequency sounder capability to Signature Series smoke and heat detectors, as well as carbon monoxide detectors when used with a SIGA-TCDR Temporal Pattern Generator. The SIGA-AB4G-LF is suitable for applications requiring low frequency audible tones.

## Typical Wiring

The detector mounting bases accept #18 AWG (0.75mm<sup>2</sup>), #16 (1.0mm<sup>2</sup>), #14 AWG (1.5mm<sup>2</sup>), and #12 AWG (2.5mm<sup>2</sup>) wire sizes. Sizes #16 AWG (1.0mm<sup>2</sup>) and #18 AWG (0.75mm<sup>2</sup>) are preferred for ease of installation.

### Standard Detector Base, SIGA-SB, SIGA-SB4

This is the basic mounting base for EDWARDS Signature Series detectors. The SIGA-LED Remote LED is supported by this Base.

Term	Description
1	Not Used
2	DATA IN/OUT (+)
3	Not Used
4	DATA IN (-)
5	Remote LED (-)
6	Not Used
7	DATA OUT (-)

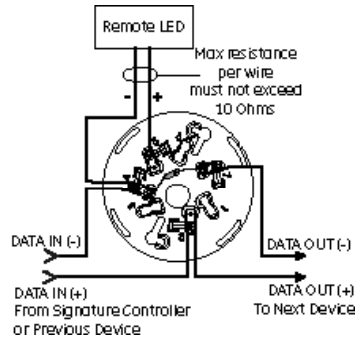

### Isolator Detector Base, SIGA-IB, SIGA-IB4

This base includes a built-in line fault isolator for use on Class A circuits. A detector must be installed for it to operate. The isolator base does not support the SIGA-LED Remote LED.

The isolator operates as follows:

- a short on the line causes all isolators to open within 23 msec.
- at 10 msec intervals, beginning on one side of the Class A circuit nearest the loop controller, the isolators close to provide the next isolator down the line with power.
- when the isolator next to the short closes, it reopens within 10 msec.

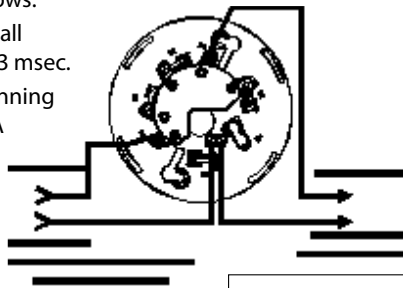

Term	Description
1	Not Used
2	DATA IN/OUT (+)
3	DATA IN (-)
4	Not Used
5	Not Used
6	DATA OUT (-)
7	Not Used

The process repeats beginning on the other side of the loop controller.

### Relay Detector Base, SIGA-RB, SIGA-RB4

This base includes a relay. Normally Open or Normally Closed operation is selected during installation. The dry contact is rated for 1 amp (pilot duty) @ 30 Vdc. The relay's position is supervised to avoid accidentally jarring it out of position. The SIGA-RB can be operated as a control relay if programmed to do so at the control panel. The relay base does not support the SIGA-LED Remote LED.

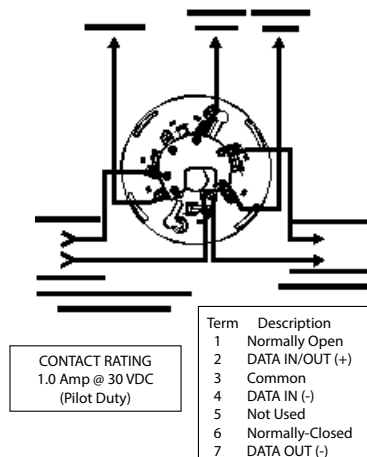

### Audible Sounder Bases, Fire Mode

AB4GT, AB4G, AB4G-LF sounder bases

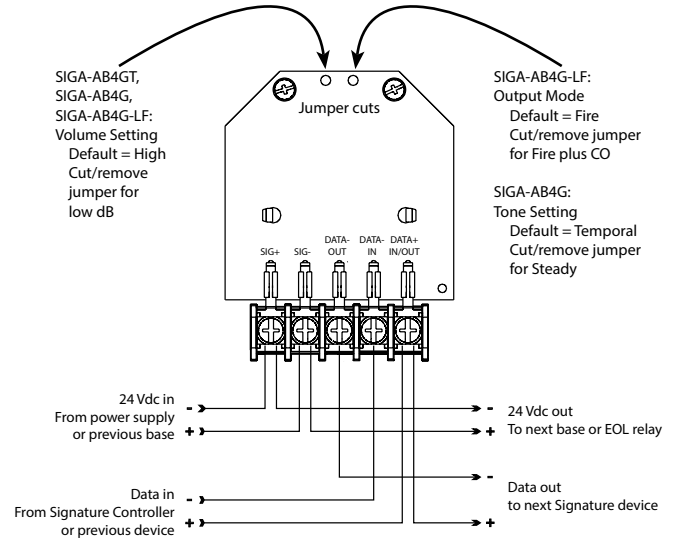

## Warnings & Cautions

- This detector does not operate without electrical power. As fires frequently cause power interruption, discuss further safeguards with the local fire protection specialist.
- This detector does not sense fires in areas where smoke cannot reach the detector. Smoke from fires in walls, roofs, or on the opposite side of closed doors may not reach the detector.
- In Canada, install according to CAN/ULC-S524 Standard for the Installation of Fire Alarm Systems, CSA C22.1 Canadian Electrical Code, and the local authority having jurisdiction.



LIFE SAFETY & INCIDENT MANAGEMENT

Contact us

Phone: 800-655-4497 (Option 4)  
 Email: [edwards.fire@carrier.com](mailto:edwards.fire@carrier.com)  
 Website: [edwardsfiresafety.com](http://edwardsfiresafety.com)

8985 Town Center Pkwy  
 Bradenton, FL 34202

© 2020 Carrier  
 All rights reserved.

## Dimensions

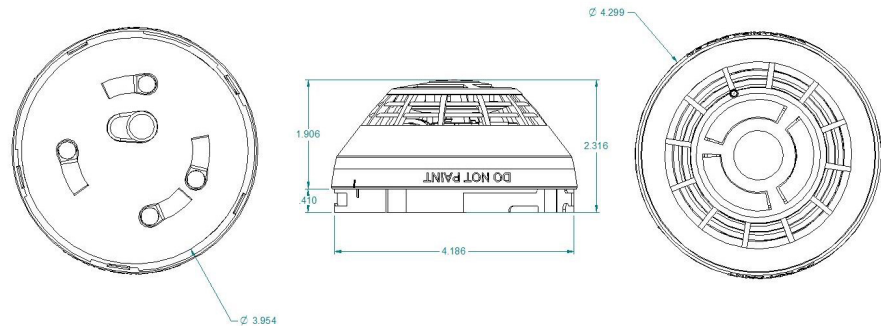

## Specifications

Operating voltage	15.20 to 19.95 VDC
Normal operating current	32 $\mu$ A
Alarm current	45 $\mu$ A
Smoke Sensitivity Range	UL/ULC: 0.5 to 4.36 %/ft. (1.6 to 13.6 %/m) obscuration
Vibration level	10 to 35 Hz, with an amplitude of 0.01 in.
Air velocity	0 to 4,000 ft./min (0 to 20 m/s)
Wall mounting	12 in. (305 mm) max. from ceiling
Compatible bases	See Ordering Information
Compatible detector testers	Testifire 1000, Testifire 2000
Operating environment	32 to 120°F (0 to 49°C), 0 to 93% RH, noncondensing
Construction	High Impact Engineering Polymer, White
Storage temperature	-4 to 140°F (-20 to 60°C)
Environmental compensation	Automatic
Agency Listings	CAN/ULC-S529, UL 268-7, UL 268A, CSFM

## Ordering Information

Catalog Number	Description	Ship Wt. lbs (kg)
<b>SIGA-OSD</b>	<b>Intelligent Optical Smoke Detector</b>	0.4 (0.16)

Accessories		
SIGA-SB	Detector Mounting Base - Standard	
<b>SIGA-SB4</b>	<b>4-inch Detector Mounting Base c/w Trim Skirt</b>	
SIGA-RB	Detector Mounting Base w/Relay	
SIGA-RB4	4-inch Detector Mounting Base w/Relay, c/w Trim Skirt	0.2 (.09)
SIGA-IB	Detector Mounting Base w/Fault Isolator	
SIGA-IB4	4-inch Detector Mounting Base w/ Fault Isolator, c/w Trim Skirt	
SIGA-LED	Remote Alarm LED (not for EN54 applications)	
SIGA-AB4G	Audible (Sounder) Base for Fire Detectors	0.3 (0.15)
SIGA-AB4G-LF	Low Frequency Audible (Sounder) Base for CO and/or Fire Detectors	0.3 (0.15)
SIGA-AB4GT	Audible (Sounder) Base for CO and/or Fire Detectors	0.3 (0.15)
SIGA-TS4	Trim Skirt (supplied with 4-inch bases)	0.1 (0.04)
SIGA-TS	Trim Skirt - (optional for non 4-inch bases)	0.1 (0.04)
SIGA-DMP	Detector Mounting Plate	3.0 (1.4)
SIGA-RTA	Detector Removal Tool	
SIGA-VA	Detector Cleaning Tool	

LIFE SAFETY &amp; INCIDENT MANAGEMENT

# Intelligent Multisensor Smoke and CO Detector

## SIGA-OSCD



## Overview

The Signature Optica Series SIGA-OSCD smoke detector brings advanced optical (photoelectric) sensing technology to a practical design that increases efficiency, saves installation time, cuts costs, and extends life safety and property protection capabilities. Continuous self-diagnostics ensure reliability over the long-haul, while environmental compensation helps reduce maintenance costs.

The SIGA-OSCD provides a combination of optical detection for the early detection of smoke, with the added element of carbon monoxide sensing. The result is a detector that pulls double duty: continually monitoring the environment for signs of fire, as well as its invisible yet deadly companion, carbon monoxide.

Like all Signature Optica Series detectors, the SIGA-OSCD is an intelligent device that gathers analog information from multiple optical sensors, converting this data into digital signals. Utilizing dual optical wavelengths combined with multiple detection angles, the SIGA-OSCD differentiates particles that are not representative of actual smoke. Particle data is input into digital filters which feed a series of ratios removing signal patterns that are typical of nuisance sources, thus reducing unwanted alarms. To make an alarm decision, the detector's on-board microprocessor measures and analyzes all optical sensor readings and compares this information to preprogrammed settings. The detector also analyzes the smoke sensor independently from the CO sensor to determine whether to initiate a fire alarm, a life safety CO alarm, or both.

## Standard Features

- Multi-criteria optical smoke sensing technology
- Integrates advanced optical smoke with life safety carbon monoxide detection
- Wide 0.5 to 4.36 %/ft. (1.6 to 13.6 %/m) smoke obscuration
- Integrated nuisance rejection reducing unwanted alarms from general cooking particulates
- Sensor Markings Provide Easy Testing Identification
- Listed to UL 268 7th edition
- Uses existing wiring
- Automatic device mapping
- Ground fault detection by module
- Up To 250 Total Signature Addresses Per Loop
- Two levels of environmental compensation
- Two levels of dirty detector warning
- Twenty pre-alarm settings
- Five sensitivity settings
- Non-volatile memory
- Electronic addressing
- Automatic day/night sensitivity adjustment
- Bicolor (green/red) status LED
- Standard, relay, fault isolator, and audible mounting bases

Note: Some features described here may not be supported by all control systems. Check your control panel's Installation and Operation Guide for details.

## Application

### Smoke detection

The SIGA-OSCD detects particles from a wide range of combustion sources and will trigger an alarm when smoke density in the chamber reaches a preprogrammed level. Thanks to its high-performance reflective response technology, the smoke sensor responds quickly and reliably to a wide range of fire types, including both fast and slow burning fires fueled by combustibles typically found in modern multi-use buildings.

### CO Detection

Monitored CO detection, such as that provided by the SIGA-OSCD, is becoming mandated with increasing frequency in all types of commercial applications, but particularly in occupancies such as hotels, rooming houses, dormitories, day care facilities, schools, hospitals, assisted living facilities, and nursing homes. Known as the "Silent Killer," CO is odorless, tasteless, and colorless. It claims nearly 500 lives, and results in more than 15,000 hospital visits annually.

## Compatibility

The Siga-OSCD detector is compatible only with control panels using a Signature Loop controller.

## Installation

Signature Series detectors mount to North American 1-gang boxes, 3-1/2 inch or 4 inch octagon boxes, and to 4 inch square electrical boxes 1-1/2 inches (38 mm) deep. They mount to European BESA and 1-gang boxes with 60.3 mm fixing centers. See mounting base installation and wiring for more information.

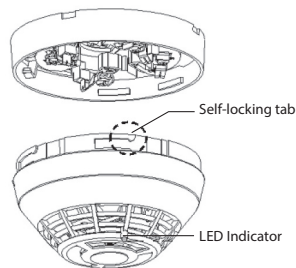

## Testing & Maintenance

Scheduled maintenance (regular or selected) for proper detector operation should be planned to meet the requirements of the Authority Having Jurisdiction (AHJ). Refer to current NFPA 72, NFPA 720, and ULC CAN/ULC 536 standards.

### Smoke Sensor Sensitivity

The SIGA-OSCD determines when its optical sensor is dirty or defective and can transmit sensitivity data to the loop controller. A sensitivity report can also be printed to satisfy NFPA sensitivity measurements which must be conducted at the end of the first year and every two years thereafter. The availability of maintenance features depends on the fire alarm system used.

### CO Sensor Life

The CO sensor has a 10-year life from the date of manufacture or when the control panel indicates a sensor end-of-life condition, whichever comes first. When the sensor reaches its end of life, the detector signals a "COMMON TRBL ACT" condition on the control panel. Pressing the Details button on the control panel displays "END OF LIFE ACT" providing verification that it is an end-of-life trouble of the CO sensor. This trouble remains active until the detector is replaced, even if the panel is reset.

## Sensing and reporting technology

The microprocessor in each detector provides additional benefits – Self-diagnostics and History Log, Automatic Device Mapping, and Fast, Stable Communication.

**Self-diagnostics and History Log** - Each Signature Series detector constantly runs self-checks to provide important maintenance information. The results of the self-check are automatically updated and permanently stored in the detector's non-volatile memory.

**Automatic Device Mapping** - The loop controller learns where each device's serial number address is installed relative to other devices on the circuit. The mapping feature provides supervision of each device's installed location to prevent a detector from being reinstalled (after cleaning, etc.) in a different location from where it was originally.

**Fast Stable Communication** - On-board intelligence means less information needs to be sent between the detector and the loop controller. Other than regular supervisory polling response, the detector only needs to communicate with the loop controller when it has something new to report.

## Accessories

**Detector mounting bases** have wiring terminals that are accessible from the "room-side" after mounting the base to the electrical box. The bases mount to North American 1-gang boxes and to 3½ inch or 4 inch octagon boxes, 1½ inches (38 mm) deep. They also mount to European BESA and 1-gang boxes with 60.3 mm fixing centers. The SIGA-SB4, SIGA-RB4, and SIGA-IB4 mount to North American 4 inch sq. electrical boxes in addition to the above boxes. They include the SIGA-TS4 Trim Skirt, which is used to cover the "mounting ears" on the base. Sounder bases mount to a 4 inch square boxes only.

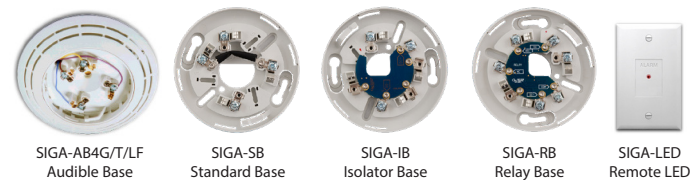

**Remote LED SIGA-LED** - The remote LED connects to the SIGA-SB or SIGA-SB4 Standard Base only. It features a North American size 1-gang plastic faceplate with a white finish and red alarm LED.

**SIGA-TS4 Trim Skirt** - Supplied with 4 inch bases, it can also be ordered separately to use with the other bases to help hide surface imperfections not covered by the smaller bases.

**Sounder Bases** - Signature Series sounder bases are designed for use where localized or group alarm signaling is required.

- SIGA-AB4GT bases provide sounder capability to the SIGA-PCD when used with a SIGA-TCDR Temporal Pattern Generator to separate CO (TC4) and Fire (TC3) tone patterns.
- SIGA-AB4G-LF bases provide 520 Hz low frequency sounder capability to the SIGA-OSCD when used with a SIGA-TCDR Temporal Pattern Generator to separate CO (TC4) and Fire (TC3) tone patterns. The SIGA-AB4G-LF is suitable for applications requiring low frequency audible tones.

## Typical Wiring

The detector mounting bases accept #18 AWG (0.75mm<sup>2</sup>), #16 (1.0mm<sup>2</sup>), #14 AWG (1.5mm<sup>2</sup>), and #12 AWG (2.5mm<sup>2</sup>) wire sizes. Sizes #16 AWG (1.0mm<sup>2</sup>) and #18 AWG (0.75mm<sup>2</sup>) are preferred for ease of installation.

### Standard Detector Base, SIGA-SB, SIGA-SB4

This is the basic mounting base for EDWARDS Signature Series detectors. The SIGA-LED Remote LED is supported by this Base.

Term	Description
1	Not Used
2	DATA IN/OUT (+)
3	Not Used
4	DATA IN (-)
4	Remote LED (-)
5	Remote LED (+)
6	Not Used
7	DATA OUT (-)

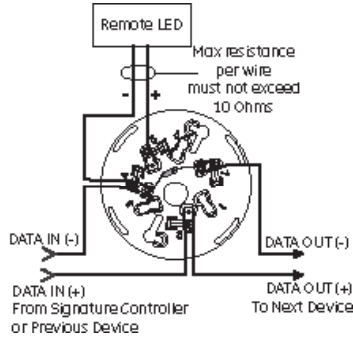

### Isolator Detector Base, SIGA-IB, SIGA-IB4

This base includes a built-in line fault isolator for use on Class A circuits. A detector must be installed for it to operate. The isolator base does not support the SIGA-LED Remote LED.

The isolator operates as follows:

- a short on the line causes all isolators to open within 23 msec.
- at 10 msec intervals, beginning on one side of the Class A circuit nearest the loop controller, the isolators close to provide the next isolator down the line with power.
- when the isolator next to the short closes, it reopens within 10 msec.

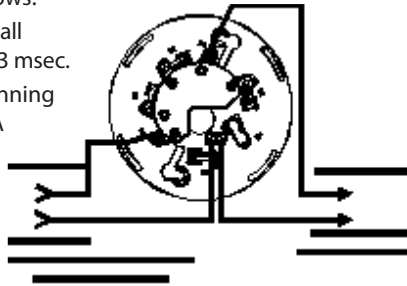

Term	Description
1	Not Used
2	DATA IN/OUT (+)
3	DATA IN (-)
4	Not Used
5	Not Used
6	DATA OUT (-)
7	Not Used

The process repeats beginning on the other side of the loop controller.

### Relay Detector Base, SIGA-RB, SIGA-RB4

This base includes a relay. Normally Open or Normally Closed operation is selected during installation. The dry contact is rated for 1 amp (pilot duty) @ 30 Vdc. The relay's position is supervised to avoid accidentally jarring it out of position. The SIGA-RB can be operated as a control relay if programmed to do so at the control panel. The relay base does not support the SIGA-LED Remote LED.

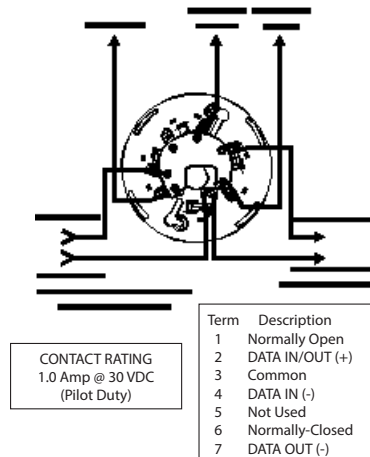

## Audible Sounder Bases, Fire Mode

AB4G, AB4GT and AB4G-LF sounder bases

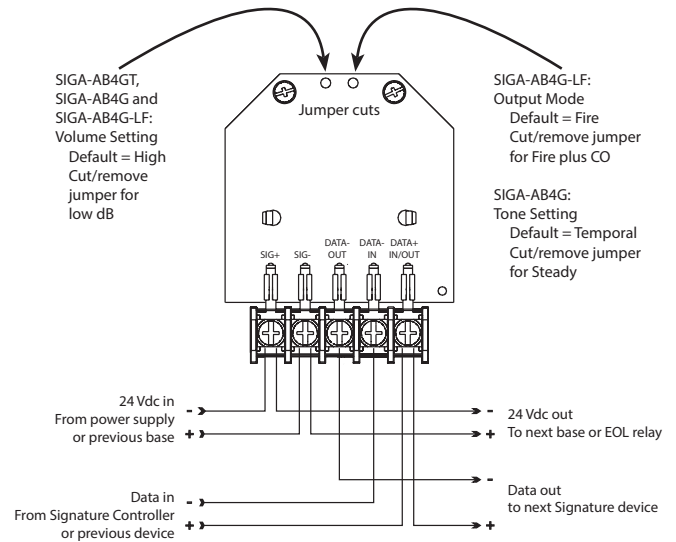

## Audible Sounder Bases, Fire-plus-CO Mode

AB4GT and AB4G-LF sounder bases only.

These configurations require a SIGA-TCDR Temporal Pattern Generator to separate CO (TC4) and Fire (TC3) tone patterns.

### Fire-plus-CO mode wiring for detector operation of bases

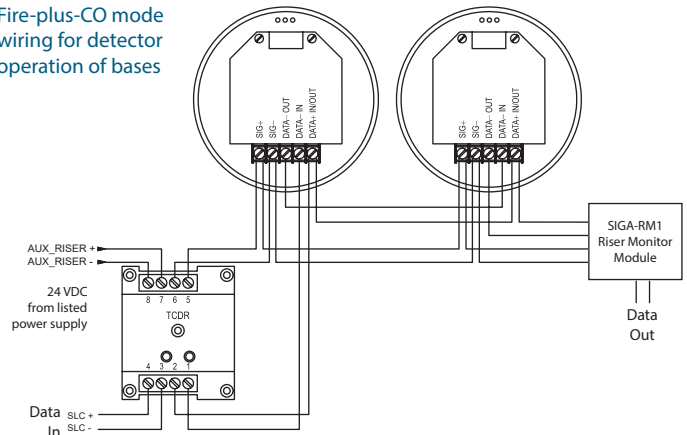

### Fire-plus-CO mode wiring for detector and system operation of bases

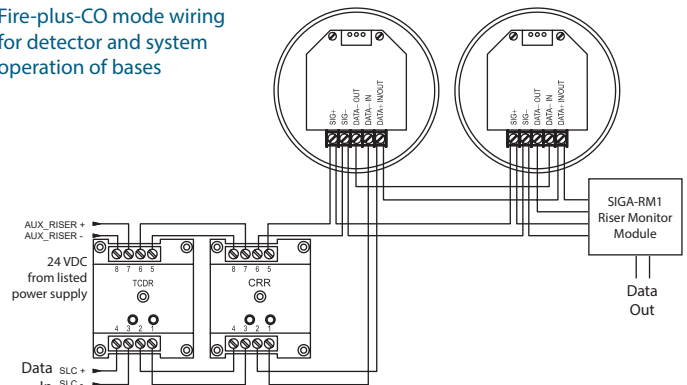



LIFE SAFETY & INCIDENT MANAGEMENT

Contact us

Phone: 800-655-4497 (Option 4)  
 Email: [edwards.fire@carrier.com](mailto:edwards.fire@carrier.com)  
 Website: [edwardsfiresafety.com](http://edwardsfiresafety.com)

8985 Town Center Pkwy  
 Bradenton, FL 34202

© 2020 Carrier  
 All rights reserved.

## Dimensions

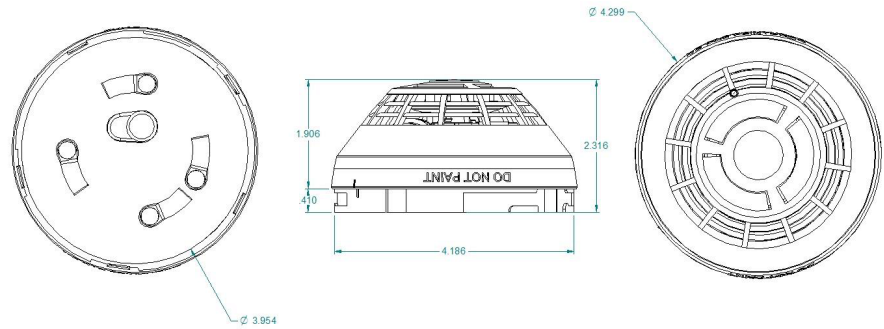

## Specifications

Operating voltage	15.20 to 19.95 VDC
Normal operating current	32 µA
Alarm current	45 µA
Smoke Sensitivity Range	UL/ULC: 0.5 to 4.36 %/ft. (1.6 to 13.6 %/m) obscuration
Vibration level	10 to 35 Hz, with an amplitude of 0.01 in.
Wall mounting	12 in. (305 mm) max. from ceiling
Compatible bases	See Ordering Information
Compatible detector testers	Testifire 1000, Testifire 2000
Operating environment	32 to 120°F (0 to 49°C), 0 to 90% RH, noncondensing
Construction	High Impact Engineering Polymer, White
Storage temperature	-4 to 140°F (-20 to 60°C)
Environmental compensation	Automatic
UL CO alarm level per UL 2034, CAN/CSA 6.19	70 ppm 60 to 240 minutes 150 ppm 10 to 50 minutes; 400 ppm 4 to 15 minutes
UL CO false alarm level per UL 2034, CAN/CSA 6.19	30 ppm 30 days 70 ppm 60 minutes
Agency Listings, SIGA-OSCD	UL 268-7, UL 2075, CSFM. Evaluated to the CO alarm sensitivity limits of UL 2034. ULC Listed to CAN/ULC-S529 and CAN/CSA 6.19.

## Warnings & Cautions

- This detector does not sense fires in areas where smoke cannot reach the detector. Smoke from fires in walls, roofs, or on the opposite side of closed doors may not reach the detector.
- Install per NFPA 72 National Fire Alarm and Signaling Code, NFPA 720 Standard for the Installation of Carbon Monoxide (CO) Detection and Warning Equipment, and UL 2075 Standard for Gas and Vapor Detectors and Sensors.

## Ordering Information

Catalog Number	Description	Ship Wt. lbs (kg)
<b>SIGA-OSCD</b>	<b>Multisensor Smoke and CO Detector</b>	0.4 (0.16)

Compatible Bases		
SIGA-SB	Detector Mounting Base - Standard	
SIGA-SB4	4-inch Detector Mounting Base c/w Trim Skirt	
SIGA-RB	Detector Mounting Base w/Relay	
SIGA-RB4	4-inch Detector Mounting Base w/Relay, c/w Trim Skirt	0.2 (.09)
SIGA-IB	Detector Mounting Base w/Fault Isolator	
SIGA-IB4	4-inch Detector Mounting Base w/ Fault Isolator, c/w Trim Skirt	
SIGA-LED	Remote Alarm LED (not for EN54 applications)	
SIGA-AB4G-LF	Low Frequency Audible (Sounder) Base for CO and Fire Detectors	0.3 (0.15)
<b>SIGA-AB4GT</b>	<b>Audible (Sounder) Base for CO and Fire Detectors</b>	0.3 (0.15)
<b>SIGA-TCDR</b>	<b>Tone Generator for Detector Sounder Bases with CO mode</b>	0.2 (0.1)
SIGA-TS4	Trim Skirt (supplied with 4-inch bases)	0.1 (.04)
SIGA-RTA	Detector Removal Tool	
SIGA-VA	Detector Cleaning Tool	



LIFE SAFETY &amp; INCIDENT MANAGEMENT

# Sounder Bases

SIGA-AB4G, SIGA-AB4G-LF,  
**SIGA-AB4GT, SIGA-TCDR**

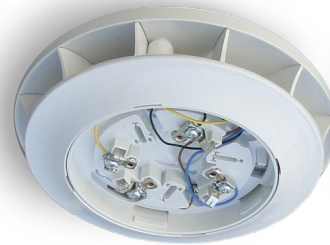

SIGA-AB4G-LF



SIGA-AB4GT



SIGA-AB4G



7300-1657:0222  
 7300-1657:0322  
 7300-1657:0308

## Overview

The Signature Series AB4G sounder bases add audible output functions to any Signature Series detector. Bases can operate as independent local alarms, or as part of a zone or system alarm with synchronized audible output.

Three models provide a full range of features that meet application needs and mandated code-compliant requirements:

**SIGA-AB4G** bases provide sounder capability to Signature Series single-function smoke detectors. They are not intended for use with combination smoke/CO devices in Fire-plus-CO mode.

**SIGA-AB4GT** bases provide sounder capability to Signature Series single-function smoke detectors, as well as combination smoke/CO detectors when used with a SIGA-TCDR Temporal Pattern Generator.

**SIGA-AB4G-LF** bases provide 520 Hz low frequency sounder capability to Signature Series single-function smoke detectors, as well as combination smoke/CO detectors in Fire-plus-CO mode when used with a SIGA-TCDR Temporal Pattern Generator. The SIGA-AB4G-LF is suitable for applications requiring low frequency audible tones.

All bases are compatible with first and second generation Signature Series intelligent detectors when properly configured.

SIGA-AB4G sounder bases match the finish of Signature Series devices, and the sound output slots complement the air entry openings of the detector. The result is a compact unit with an attractive appearance.

## Standard Features

- **Low frequency model available**  
Code-compliant 520 Hz output.
- **Temporal or steady tone**  
Jumper selects steady or synchronized temporal output.
- **High or low dB output**  
Jumper selects low or high dBA output.
- **Single or group operation**  
Optional polarity reversing module configures base for group alarm output.
- **UL268 and UL464 listed**  
UL listing under smoke detector and audible signal standards allows application as smoke alarm and/or audible signal.
- **Attractive installation**  
Flush mount to a wide selection of North American boxes or surface mount to optional custom-matched box.



## Application

Signature Series AB4G sounder bases are for use with Signature Series detectors in applications where localized or group alarm signaling is required. They are listed by Underwriters Laboratories under the UL268 and UL464 standards, allowing their application where both life safety alarms and/or notification appliances are required.

## Programming and Field Configuration

Each AB4G base uses the same address and programming label as the detector it supports.

AB4G sounder bases can be set to simply operate according to the state of its detector, or configured through system programming to operate in conjunction with all sounder bases on the same circuit. They can also be controlled by program rules. Available operating modes are determined by the system that supports the Signature data loop.

Bases may be configured in the field for either high or low dB output. When used for fire alarm-only applications (i.e.: not with CO detectors), AB4G bases may be configured for steady or temporal output. The default setting is high dB with temporal output.

## Group Activation and Synchronization

AB4G sounder bases on the same circuit may be activated as a group or zone with the use of a SIGA-CRR polarity reversal module, and the group or zone may be synchronized audible output with the use of a G1M-RM signal master.

## Combination Smoke/CO Applications

SIGA-AB4GT and SIGA-AB4G-LF audible bases may be used with combination smoke/CO detectors when a SIGA-TCDR is installed on the same Signature data loop.

The output of these bases is field-configurable for Fire Alarm mode, or Fire Alarm plus CO Alarm mode. The SIGA-AB4G-LF has two operating modes: fire output only, where the unit produces a T3 tone; and, a Fire-plus-CO mode. In the Fire-plus-CO mode, the NAC circuit requires a SIGA-TCDR module to generate and synchronize the TC3 and TC4 tones. These two distinctive tones are necessary to differentiate fire alarm signals from CO alarm signals.

Depending on the system supporting the Signature loop, the base can follow the state of the device it supports, or be controlled by program rules.

## Low Frequency Applications

The low frequency model (SIGA-AB4G-LF), features a distinctive 520 Hz signal and is ideal for hotels, dormitories, and other commercial sleeping occupancies. This base can be set for low dB output with a jumper cut that reduces audible output by about 4 dB. For commercial sleeping rooms, most codes and standards require 75 dBA-fast at the pillow.

## SIGA-TCDR Temporal Pattern Generator

The SIGA-TCDR Temporal Pattern Generator is an addressable device that generates CO and fire signal sound patterns for AB4GT and AB4G-LF sounder bases. The control panel sends synchronization and channel commands to the SIGA-TCDR; the channel selection determines the pattern. In the U.S. Channel 1 is TC3 and Channel 2 is TC4. In Europe, Channel 1 is TC4 and Channel 2 is TC3 (in case both channels are activated Channel 1 has priority). Other markets depend on local requirements.

### Temporal patterns

Name	Code	Used for
TC4	NFPA 720	CO
TC3	NFPA 72	Fire

The SIGA-TCDR module uses two addresses on the signaling line circuit (SLC). Address 1 is tied to Channel 1; Address 2 is tied to Channel 2.

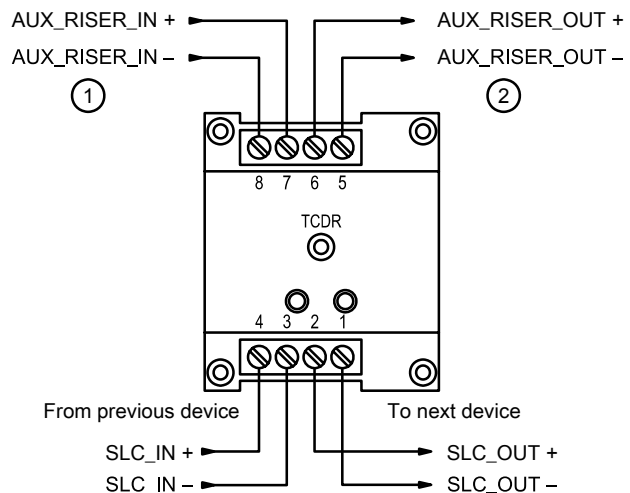

1. Use a power-limited and regulated 24 VDC primary or auxiliary power supply that is UL/ULC listed for fire protective signaling systems.
2. Power out to AB4GT sounder base or listed EOL relay and supervising module

Depending on the type of alarm, the panel can select the corresponding pattern and send the activation command to the SIGA-TCDR.

To control all sounder bases in the loop, use a SIGA-CRR module. The panel sends a signal to the SIGA-CRR causing it to reverse polarity. With the polarity on the riser reversed, all the sounder bases on this loop activate. The SIGA-TCDR maintains synchronization by processing the SYNC commands from the loop controller.

EDWARDS recommends that fire alarm systems and their devices always be installed in accordance with the latest recognized edition of national and local fire alarm codes.

# Installation and Mounting

## Flush Mounting

The sounder base flush mounts into 2-1/8 inch (54 mm) deep standard North American 4 inch square electric box, North American 4 x 4 inch octagonal concrete ring (mud box), and standard European 100 mm square electric boxes. The terminal block makes field wire connections fast and efficient. After wiring, a simple push and twist motion locks the Signature detector into the base.

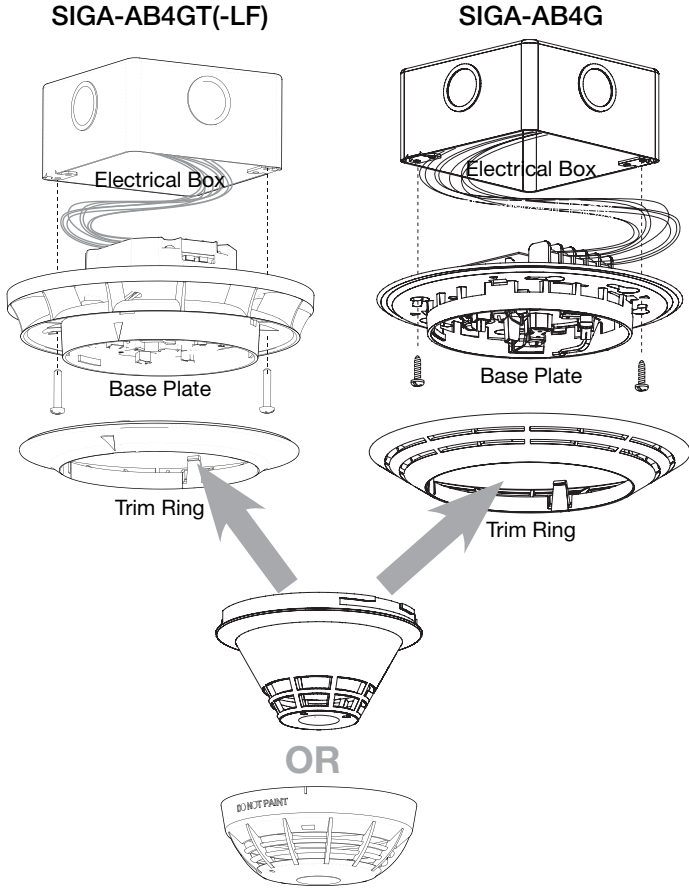

## Surface Mounting



**AB4G-SB**  
Optional Surface Box  
(6.8" diameter x 1.8" deep)

**AB4G-SB:** When using the AB4G-SB surface mount box, install a reinforcing plate at every knockout. (Reinforcing plates are included with the box.) Remove the knockout first, and then slide the reinforcing plate into the plastic housing. After the plate is in place, install a conduit connector and nut (not supplied).

# Configuration and Wiring

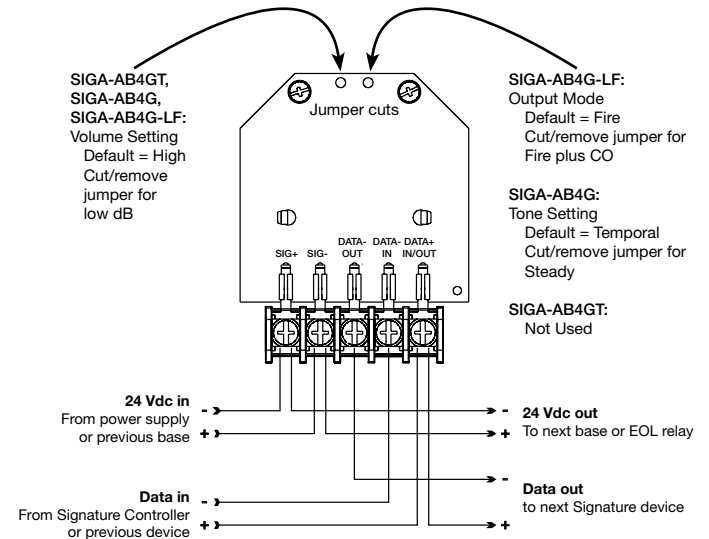

## Typical Wiring, Fire-plus-CO mode AB4GT, AB4G-LF sounder bases

### Fire-plus-CO mode wiring for detector operation of bases

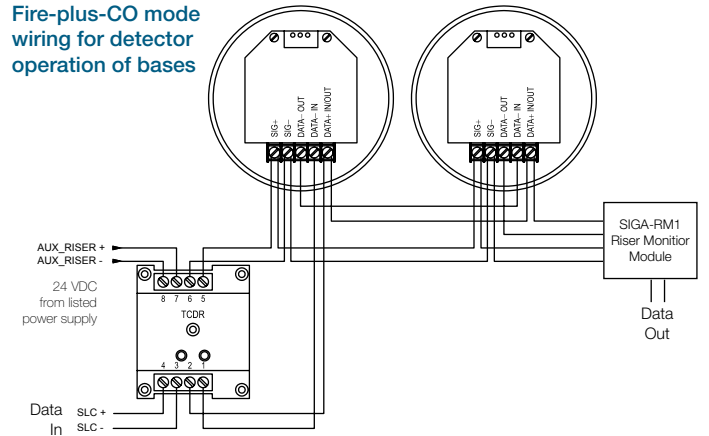

### Fire-plus-CO mode wiring for detector and system operation of bases

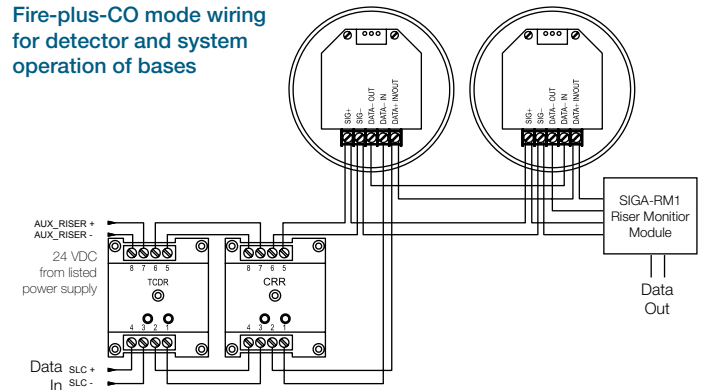

# Typical Wiring, Fire mode

## AB4G, AB4G-LF sounder bases

### Detector operates the base

The base follows the state of the detector, going into and out of alarm with the detector. The Signature CR module is optional, and is used to silence the bases on the line.

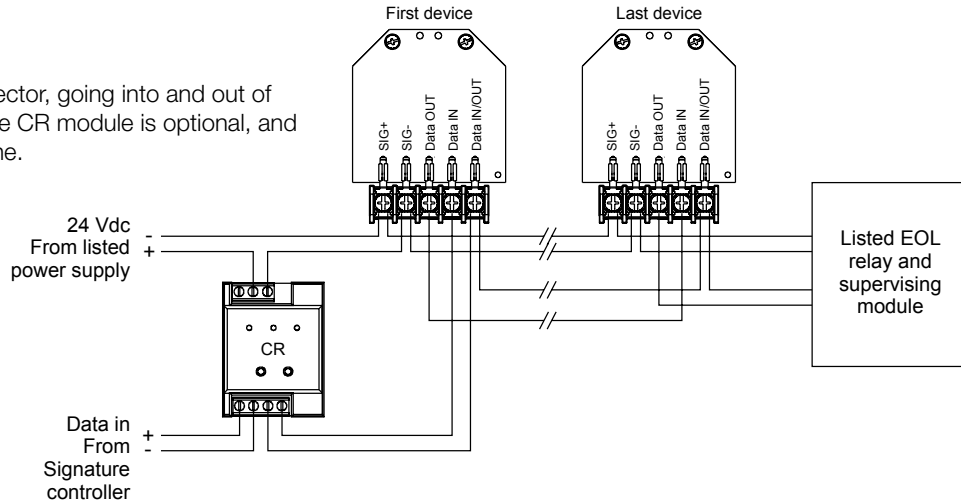

### System turns on all bases

All bases on the line can be activated by system programming that triggers the Signature CRR to reverse the supplied polarity. The Signature CR module is optional, and is used to silence the bases on the line.

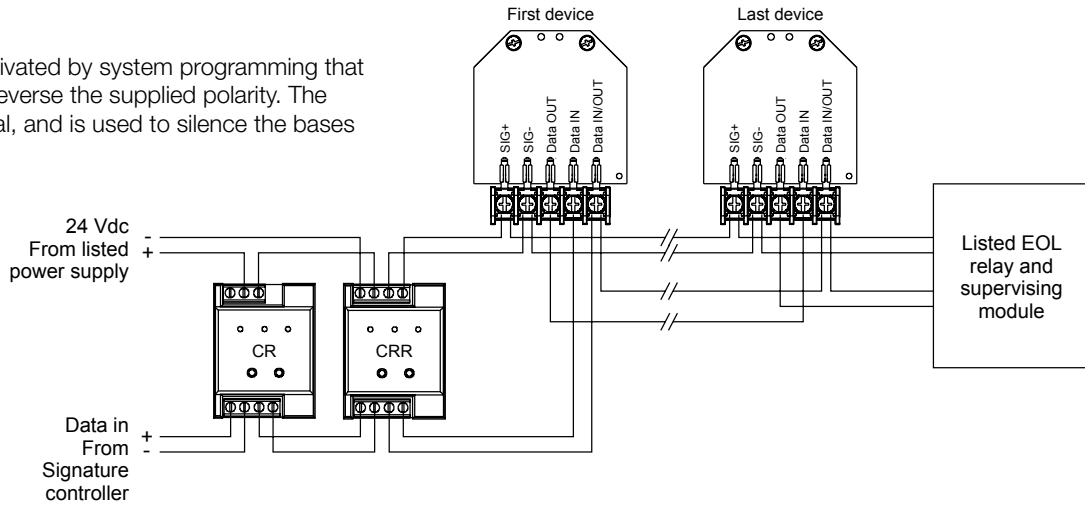

### System turns on bases with synchronization

All bases on the line are activated by system programming that triggers the Signature CRR module. The temporal output is synchronized by the G1M-RM. If the Signature CRR module is not activated, each detector can still operate its base, but the bases will not be synchronized. The Signature CR module is optional, and is used to silence the bases on the line.

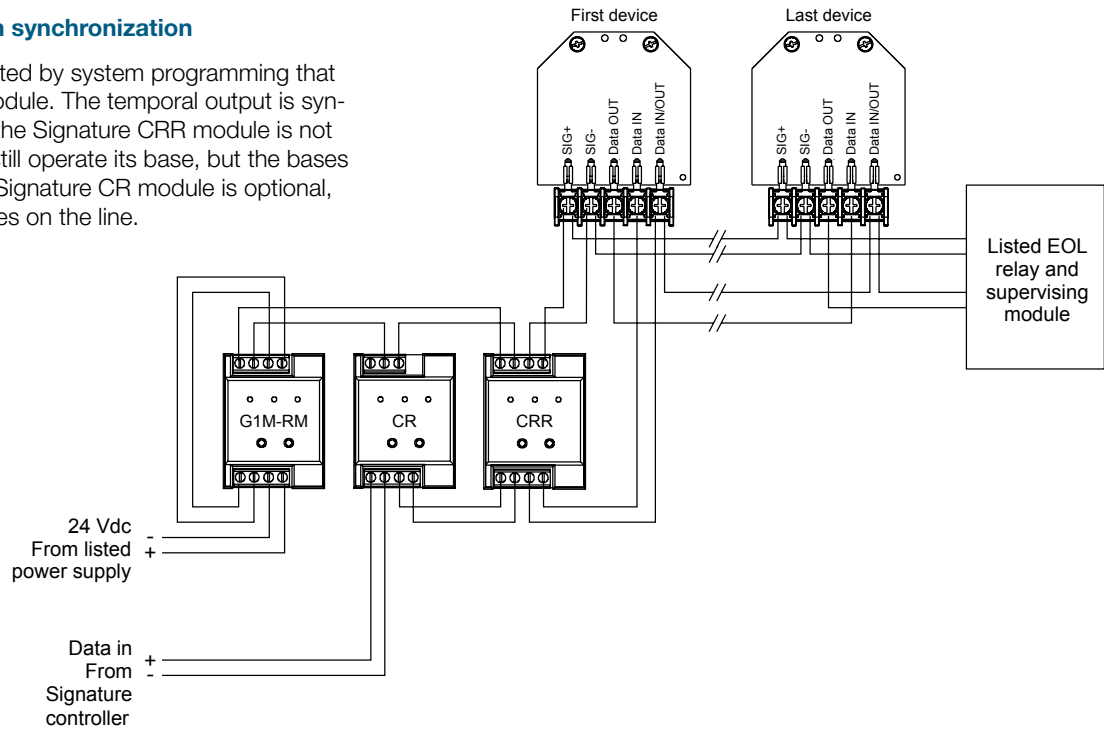

## Sound Level Output, AB4G-LF

Signal	Low dBA	High dBA <sup>1</sup>
<b>Nominal Sound Level <sup>2</sup></b>		
Steady/T3/T4	83	87
<b>Per UL 268, UL 521, UL 2075 (reverberant) <sup>3</sup></b>		
TC3 (fire pattern)	76.3	80.8
TC4 (CO pattern)	73.0	77.4
Steady	80.9	85.3

<b>Per UL 464 (reverberant) <sup>3</sup></b>		
TC3 (fire pattern)	70.3	74.8
TC4 (CO pattern)	67.0	71.4
Steady	74.9	79.3

<sup>1</sup> For NFPA 72 and NFPA 720 applications, the high dBA settings can be used for public mode evacuation.

<sup>2</sup> Anechoic chamber @ 10ft

<sup>3</sup> As measured in a UL reverberant room at 10 ft.

## Operating Current, AB4G-LF

mA RMS UL/ULC ratings

Signal	Low dBA			High dBA		
	16 VDC	24 VDC	33 VDC	16 VDC	24 VDC	33 VDC
TC3	76.0	76.4	85.6	92.0	76.0	93.6
TC4	112.8	148.0	125.6	107.2	150.0	150.8
Steady	75.2	76.0	92.4	143.0	92.0	97.0

## Sound Level Output, AB4G

Signal	Voltage	Low dBA	High dBA
<b>Reverberant room per UL 464*</b>			
Temporal	16 Vdc	71.5	78.1
	24 Vdc	75.5	80.7
	33 Vdc	78.5	83.1
Steady	16 Vdc	75.5	81.7
	24 Vdc	79.5	84.5
	33 Vdc	81.8	86.5

<b>Reverberant room per UL 268</b>			
Temporal	16 Vdc	77.5	84.1
	24 Vdc	81.5	86.7
	33 Vdc	84.5	89.1
Steady	16 Vdc	81.5	87.7
	24 Vdc	85.5	90.5
	33 Vdc	87.8	92.5

dBA = Decibels, A-weighted

\*For UL 464 applications low dBA settings are for private mode only.

## Operating Current (RMS), AB4G

Voltage	Low dBA	High dBA	Notes
16 VDC	17	28	VDC = Volts direct current, regulated and filtered
24 VDC	24	41	
33 VDC	31	52	
16 VFWR	41	48	VFWR = Volts full wave rectified
24 VFWR	51	60	
33 VFWR	60	66	

## Sound Level Output, AB4GT

Signal	Voltage	Low dBA	High dBA
<b>Reverberant room per UL 464 <sup>1</sup></b>			
TC3 (fire pattern)	16 VDC	80.5	85.2
TC4 (CO pattern)	16 VDC	73.9	77.5
<b>Reverberant room per UL 268 and FM <sup>2</sup></b>			
TC3 (fire pattern)	16 VDC	86.5	90.8
TC4 (CO pattern)	16 VDC	77.5	84.1
<b>Sound pressure level per CAN/ULC-S525 <sup>3</sup></b>			
Temporal	24 VDC	95	91
Steady	24 VDC	93	89

<sup>1</sup> For UL 464 applications, low dBA settings are for private mode only.

<sup>2</sup> For UL 268 applications, the high setting must be used for evacuation.

<sup>3</sup> Voltage is regulated and filtered.

## Operating current (RMS), AB4GT

Low dBA	High dBA
31 mA	52 mA



LIFE SAFETY & INCIDENT MANAGEMENT

**Contact us**

Phone: 800-655-4497 (Option 4)  
 Email: [edwards.fire@carrier.com](mailto:edwards.fire@carrier.com)  
 Website: [edwardsfiresafety.com](http://edwardsfiresafety.com)

8985 Town Center Pkwy  
 Bradenton, FL 34202

© 2020 Carrier  
 All rights reserved.

## Specifications

	SIGA-AB4G	SIGA-AB4GT	SIGA-AB4G-LF
Riser operating voltage	16 to 33 VDC		
Operating Current	See tables on previous page		
Supervisory Current	DC = 1.46 mA, FWR = 2.15 mA	DC = 1.46 mA	DC = 6.0 mA
Default Output Volume	High dBA		
Default Tone	Temporal	Fire: Steady or TC3; Fire-plus-CO: TC3 or TC4	
Resonant frequency	3.2 kHz		520 Hz +/- 10%
Temporal pattern	0.5 s on, 0.5 s off, 0.5 s on, 0.5 s off, 0.5 s on, 1.5 s off, repeat cycle	As determined by the SIGA-TCDR... Fire: Steady or TC3; Fire-plus-CO: TC3 or TC4	
Compatible detectors	All Signature Series detectors		
Compatible electrical boxes	AB4G-SB surface box for audible base; 4 in. square by 2-1/8 in. (54 mm) deep box; 3-1/2 in. octagonal by 2-1/8 in. (54 mm) deep box; Standard European 100 mm <sup>2</sup> box		
Wire size	12 to 18 AWG (0.75 to 2.50 mm <sup>2</sup> )		
Base diameter	6.8 in. (173 mm)		
Base height from box	0.8 in. (21 mm)	1.4 in. (35 mm)	
Maximum distance from ceiling	Wall mount – 12 in. (305 mm)		
Environment type	Indoor only		
Operating environment	Temperature 32 to 120°F (0 to 49°C) Relative humidity 0 to 93% noncondensing		
Storage temperature	-4 to 140°F (-20 to 60°C)		
Listings	UL, ULC, CSFM		UL, CSFM

## Ordering Information

Catalog Number	Description	Ship Wt., lb. (kg)
SIGA-AB4G-LF	Low Frequency Sounder Base for CO and Fire Detectors	0.3 (0.15)
SIGA-AB4GT	Sounder Base for CO and Fire Detectors	0.3 (0.15)
SIGA-AB4G	Sounder Base for Fire Detectors	0.3 (0.15)

Related Equipment		
Catalog Number	Description	Ship Wt., lb. (kg)
SIGA-TCDR	Temporal Pattern Generator	0.2 (0.1)
SIGA-MCRR	Polarity Reversal Relay (Plug-in UIO module)	0.18 (0.08)
SIGA-CRR	Polarity Reversal Relay (Standard mount module)	0.2 (0.1)
SIGA-MCR	Control Relay Module (Plug-in UIO module)	0.18 (0.08)
SIGA-CR	Control Relay Module (Standard mount module)	0.2 (0.1)
SIGA-RM1	Riser Monitor Module	0.2 (0.1)
G1M-RM	Signal Master (1-gang remote mount)	0.2 (0.1)
AB4G-SB	Surface Box for Audible Base	1.0 (0.45)

LIFE SAFETY &amp; INCIDENT MANAGEMENT

# Intelligent Heat Detectors

**SIGA-HRD**, SIGA-HFD

## Overview

The Signature Series smoke detectors bring advanced sensing technology to a practical design that increases efficiency, saves installation time, cuts costs, and extends property protection capabilities. Continuous self-diagnostics ensures reliability over the long-haul, while the latest thermister technology makes these detectors ideal wherever dependable heat detection is required.

**The SIGA-HRD** is an intelligent fixed temperature/rate-of-rise fire detector. It monitors the temperature of the surrounding air and analyzes the data from the sensor to determine whether to initiate an alarm. The rate-of-rise heat function quickly detects a fast, flaming fire. The fixed-temperature heat function detects fire when the air temperature near the detector exceeds the alarm point.

**The SIGA-HFD** is an intelligent fixed-temperature heat detector that contains a fixed-temperature heat sensor rated at 135 °F (57.2 °C). It does not have a rate-of-rise function. The heat sensor monitors the temperature of the air in its surroundings and the detector analyzes the data to determine when the air temperature near the detector exceeds the device's alarm point.

## Standard Features

**Note:** Some features described here may not be supported by all control systems. Check your control panel's *Installation and Operation Guide* for details.

- Next Generation Heat Sensing Technology
- 135 °F (57 °C) fixed temperature alarm point (HRD and HFD)
- 15 °F (9 °C) per minute rate-of-rise alarm point (HRD)
- Uses existing wiring
- Automatic device mapping
- Sensor Markings Provide Easy Testing Identification
- Up To 250 Total Signature Devices Per Loop
- Non-volatile memory
- Electronic addressing
- Bicolor (green/red) status LED
- Standard, relay, fault isolator, and audible mounting bases
- 50 foot (15.2 meter) spacing

## Application

The SIGA-HRD combination fixed temperature/rate-of-rise heat detector provides a 15 °F (9 °C) per minute rate-of-rise heat sensor for the detection of fast-developing fires, as well as a 135°F (57°C) fixed temperature sensor for slow building-fires. The SIGA-HFD fixed temperature detector provides a 135°F (57°C) fixed temperature sensor for slow building-fires.

## Compatibility

Signature Series heat detectors are compatible only with the Signature Loop Controller.

## Installation

Signature Series detectors mount to North American 1-gang boxes, 3-1/2 inch or 4 inch octagon boxes, and to 4 inch square electrical boxes 1-1/2 inches (38 mm) deep. They mount to European BESA and 1-gang boxes with 60.3 mm fixing centers. See mounting base installation and wiring for more information.

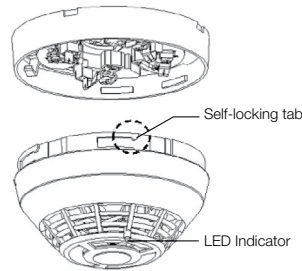

## Sensing and reporting technology

The microprocessor in each detector provides additional benefits - Self-diagnostics and History Log, Automatic Device Mapping, and Fast, Stable Communication.

**Self-diagnostics and History Log** - Each Signature Series detector constantly runs self-checks to provide important maintenance information. The results of the self-check are automatically updated and permanently stored in the detector's non-volatile memory.

**Automatic Device Mapping** - The loop controller learns where each device's serial number address is installed relative to other devices on the circuit. The mapping feature provides supervision of each device's installed location to prevent a detector from being reinstalled (after cleaning etc.) in a different location from where it was originally.

**Fast Stable Communication** - On-board intelligence means less information needs to be sent between the detector and the loop controller. Other than regular supervisory polling response, the detector only needs to communicate with the loop controller when it has something new to report.

## Accessories

**Detector mounting bases** have wiring terminals that are accessible from the "room-side" after mounting the base to the electrical box. The bases mount to North American 1-gang boxes and to 3½ inch or 4 inch octagon boxes, 1½ inches (38 mm) deep. They also mount to European BESA and 1-gang boxes with 60.3 mm fixing centers. The SIGA-SB4, SIGA-RB4, and SIGA-IB4 mount to North American 4 inch sq. electrical boxes in addition to the above boxes. They include the SIGA-TS4 Trim Skirt, which is used to cover the "mounting ears" on the base. The SIGA-AB4G mounts to a 4 inch square box only.

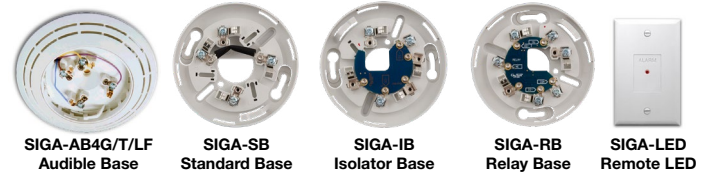

**Remote LED SIGA-LED** - The remote LED connects to the SIGA-SB or SIGA-SB4 Standard Base only. It features a North American size 1-gang plastic faceplate with a white finish and red alarm LED.

**SIGA-TS4 Trim Skirt** - Supplied with 4 inch bases, it can also be ordered separately to use with the other bases to help hide surface imperfections not covered by the smaller bases.

**Sounder Bases** - Signature Series sounder bases are designed for use where localized or group alarm signaling is required.

- **SIGA-AB4G** bases provide sounder capability to Signature Series to heat and smoke detectors. They are not intended for use with combination carbon monoxide detectors in Fire-plus-CO mode.
- **SIGA-AB4GT** bases provide sounder capability to Signature Series smoke and heat detectors, as well as carbon monoxide detectors when used with a SIGA-TCDR Temporal Pattern Generator.
- **SIGA-AB4G-LF** bases provide 520 Hz low frequency sounder capability to Signature Series smoke and heat detectors, as well as carbon monoxide detectors when used with a SIGA-TCDR Temporal Pattern Generator. The SIGA-AB4G-LF is suitable for applications requiring low frequency audible tones.

## Warnings & Cautions

- This detector does not operate without electrical power. As fires frequently cause power interruption, discuss further safeguards with the local fire protection specialist.
- This detector does not sense fires in areas where heat cannot reach the detector. Heat from fires in walls, roofs, or on the opposite side of closed doors may not reach the detector.
- This heat detector by itself does not provide life safety protection. Use this detector with ionization and/or photoelectric smoke detectors.
- This detector does not detect oxygen levels, smoke, toxic gases, or flames. Use this device as part of a broad-based life safety program which includes a variety of information sources pertaining to heat and smoke levels, extinguishment systems, visual and audible devices, and other safety measures.
- Independent studies indicate that heat detectors should only be used when property protection alone is involved. Never rely on heat detectors as the sole means of fire protection.

## Typical Wiring

The detector mounting bases accept #18 AWG (0.75mm<sup>2</sup>), #16 (1.0mm<sup>2</sup>), #14 AWG (1.5mm<sup>2</sup>), and #12 AWG (2.5mm<sup>2</sup>) wire sizes. Sizes #16 AWG (1.0mm<sup>2</sup>) and #18 AWG (0.75mm<sup>2</sup>) are preferred for ease of installation.

### Standard Detector Base, SIGA-SB, SIGA-SB4

This is the basic mounting base for EDWARDS Signature Series detectors. The SIGA-LED Remote LED is supported by this Base.

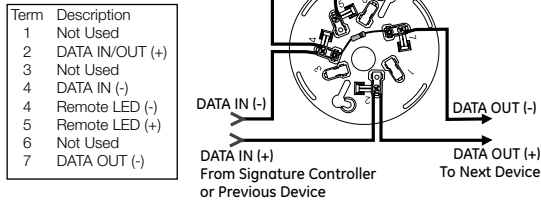

### Isolator Detector Base, SIGA-IB, SIGA-IB4

This base includes a built-in line fault isolator for use on Class A circuits. A detector must be installed for it to operate. The isolator base does not support the SIGA-LED Remote LED.

The isolator operates as follows:

- a short on the line causes all isolators to open within 23 msec
- at 10 msec intervals, beginning on one side of the Class A circuit nearest the loop controller, the isolators close to provide the next isolator down the line with power
- when the isolator next to the short closes, it reopens within 10 msec.

The process repeats beginning on the other side of the loop controller.

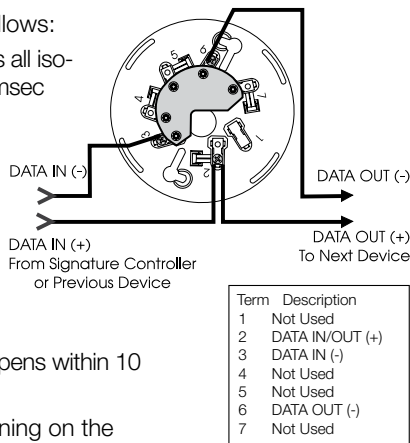

### Relay Detector Base, SIGA-RB, SIGA-RB4

This base includes a relay. Normally Open or Normally Closed operation is selected during installation. The dry contact is rated for 1 amp (pilot duty) @ 30 Vdc. The relay's position is supervised to avoid accidentally jarring it out of position. The SIGA-RB can be operated as a control relay if programmed to do so at the control panel. The relay base does not support the SIGA-LED Remote LED.

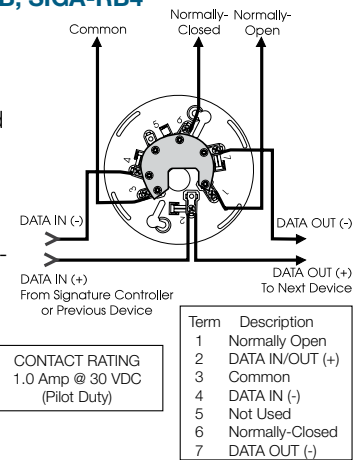

### Audible Sounder Bases, Fire Mode

AB4GT, AB4G, AB4G-LF sounder bases

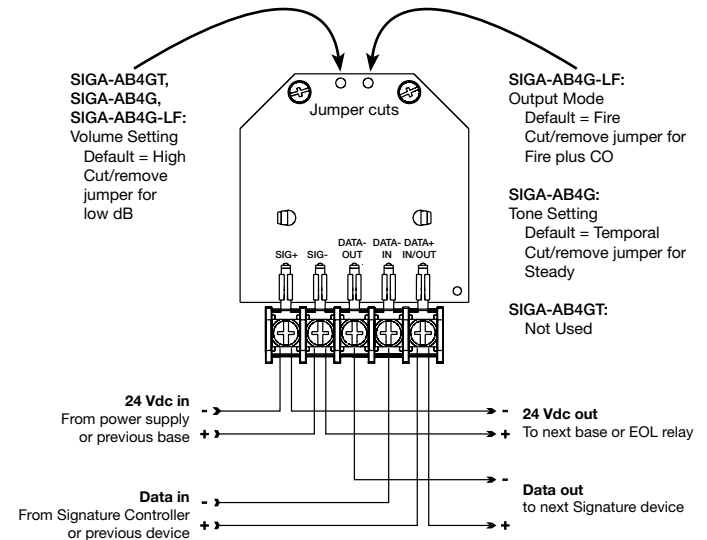





LIFE SAFETY & INCIDENT MANAGEMENT

**Contact us**

Phone: 800-655-4497 (Option 4)  
 Email: [edwards.fire@carrier.com](mailto:edwards.fire@carrier.com)  
 Website: [edwardsfiresafety.com](http://edwardsfiresafety.com)

8985 Town Center Pkwy  
 Bradenton, FL 34202

© 2020 Carrier  
 All rights reserved.

## Dimensions

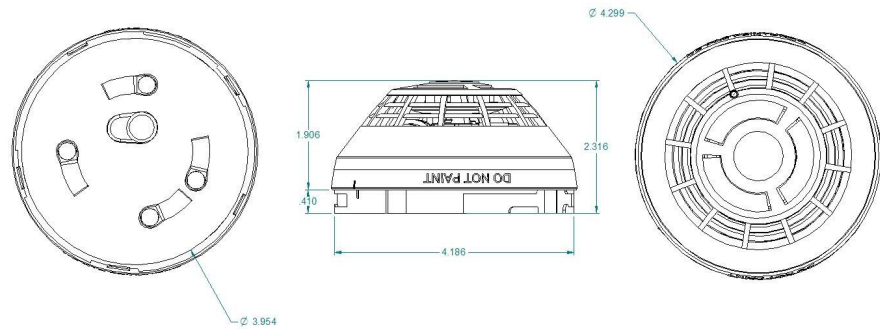

## Specifications

	SIGA- HRD	SIGA-HFD
Operating voltage	15.20 to 19.95 VDC	
Normal operating current	32 µA	
Alarm current	32 µA	
Vibration level	10 to 35 Hz, with an amplitude of 0.01 in.	
Rate-of-rise rating	15°F/min (8°C/min)	NA
Fixed temperature rating	135°F (57.2°C). Actual alarm point 129 to 141°F (53.9 to 60.6°C).	
Maximum spacing	50 ft. (15.2 m) centers	
Compatible bases	See Ordering Information	
Compatible detector testers	Testifire 1000, Testifire 2000	Testifire 2000
Operating environment	32 to 100°F (0 to 38°C), 0 to 93% RH, noncondensing	
Construction	High Impact Engineering Polymer, White	
Storage temperature	-4 to 140°F (-20 to 60°C)	
Agency Listings	CAN/ULC-S530, UL 521	CAN/ULC-S530-M91, UL 521

## Ordering Information

Catalog Number	Description	Ship Wt. lbs (kg)
SIGA-HRD	Intelligent fixed temperature/Rate-of-rise heat detector	0.4 (0.16)
SIGA-HFD	Intelligent fixed temperature heat detector	

Compatible Bases		
SIGA-SB	Detector Mounting Base - Standard	
SIGA-SB4	4-inch Detector Mounting Base c/w Trim Skirt	
SIGA-RB	Detector Mounting Base w/Relay	0.2 (.09)
SIGA-RB4	4-inch Detector Mounting Base w/Relay, c/w Trim Skirt	
SIGA-IB	Detector Mounting Base w/Fault Isolator	
SIGA-IB4	4-inch Detector Mounting Base w/ Fault Isolator, c/w Trim Skirt	
SIGA-AB4G	Audible (Sounder) Base for Fire Detectors	
SIGA-AB4G-LF	Low Frequency Audible (Sounder) Base for CO and Fire Detectors	0.3 (0.15)
SIGA-AB4GT	Audible (Sounder) Base for CO and Fire Detectors	
SIGA-LED	Remote Alarm LED (not for EN54 applications)	
SIGA-TS4	Trim Skirt (supplied with 4-inch bases)	0.1 (0.04)
SIGA-TS	Trim Skirt (optional for non 4-inch bases)	
SIGA-RTA	Detector Removal Tool	



LIFE SAFETY &amp; INCIDENT MANAGEMENT

# Manual Pull Stations

SIGA-270, SIGA-270P,  
**SIGA-278**



SIGA-278

SIGA-270 SERIES

Patented

MEGA FM APPROVED 7150-1657:0129



## Overview

The SIGA-270 and SIGA-278 series Manual Pull Stations are part of EDWARDS's Signature Series system. The SIGA-270 Fire Alarm Manual Pull Stations feature our very familiar teardrop shape. They are made from die-cast zinc and finished with red epoxy powder-coat paint complemented by aluminum colored stripes and markings. With positive pull-lever operation, one pull on the station handle breaks the glass rod and turns in a positive alarm, ensuring protection plus fool-proof operation. Presignal models (SIGA-270P) are equipped with a general alarm (GA) keyswitch for applications where two stage operation is required. The up-front highly visible glass rod discourages tampering, but is not required for proper operation.

EDWARDS's double action single stage SIGA-278 station is a contemporary style manual station made from durable red colored lexan. To initiate an alarm, first lift the upper door marked "LIFT THEN PULL HANDLE", then pull the alarm handle.

## Standard Features

**Note:** Some features described here may not be supported by all control systems. Check your control panel's Installation and Operation Guide for details.

- **Traditional familiar appearance**  
SIGA-270 models feature our familiar teardrop design with simple positive pull action and sturdy die-cast metal body.
- **One stage (GA), two stage (pre-signal), and double action models**  
SIGA-270 models are available for one or two stage alarm systems. The single stage double action SIGA-278 features a rugged Lexan housing with keyed reset mechanism.

- **Break glass operation**  
An up-front visible glass rod on the SIGA-270 discourages tampering.
- **Intelligent device with integral microprocessor**  
All decisions are made at the station allowing lower communication speed while substantially improving control panel response time. Less sensitive to line noise and loop wiring properties; twisted or shielded wire is not required.
- **ADA Compliant**  
Meets ADA requirements for manual pull stations.
- **Electronic Addressing with Non-volatile memory**  
Permanently stores programmable address, serial number, type of device, and job number. Automatically updates historic information including hours of operation, last maintenance date, number of alarms and troubles, and time and date of last alarm.
- **Automatic device mapping**  
Each station transmits wiring information to the loop controller regarding its location with respect to other devices on the circuit.
- **Diagnostic LEDs**  
Status LEDs; flashing GREEN shows normal polling; flashing RED shows alarm state.
- **Designed for high ambient temperature operation**  
Install in ambient temperatures up to 120 °F (49 °C).

## Application

The operating characteristics of the fire alarm stations are determined by their sub-type code or "Personality Code". NORMALLY-OPEN ALARM - LATCHING (Personality Code 1) is assigned by the factory; no user configuration is required. The device is configured for Class B IDC operation. An ALARM signal is sent to the loop controller when the station's pull lever is operated. The alarm condition is latched at the station.

## Compatibility

Signature Series manual stations are compatible only with EDWARDS's Signature Loop Controller.

## Warnings & Cautions

This device will not operate without electrical power. As fires frequently cause power interruption, we suggest you discuss further safeguards with your local fire protection specialist.

## Testing & Maintenance

To test (or reset) the station simply open the station and operate the exposed switch. The SIGA-270 series are opened with a tool; the SIGA-278 requires the key which is supplied with that station.

The station's automatic self-diagnosis identifies when it is defective and causes a trouble message. The user-friendly maintenance program shows the current state of each Signature series device and other pertinent messages. Single devices may be deactivated temporarily, from the control panel. Availability of maintenance features is dependent on the fire alarm system used.

Scheduled maintenance (Regular or Selected) for proper system operation should be planned to meet the requirements of the Authority Having Jurisdiction (AHJ). Refer to current NFPA 72 and ULC CAN/ULC 536 standards.

## Typical Wiring

The fire alarm station's terminal block accepts #18 AWG (0.75mm<sup>2</sup>) to #12 AWG (2.5mm<sup>2</sup>) wire sizes. See Signature Loop Controller catalog sheet for detailed wiring requirement specifications.

### Wiring Notes

1. Refer to Signature Loop Controller manual for maximum wire distance.
2. All wiring is power limited and supervised.

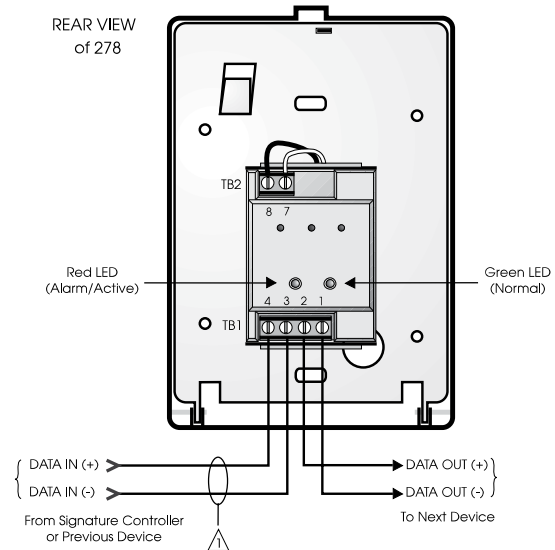

Figure 4. Single Stage Systems

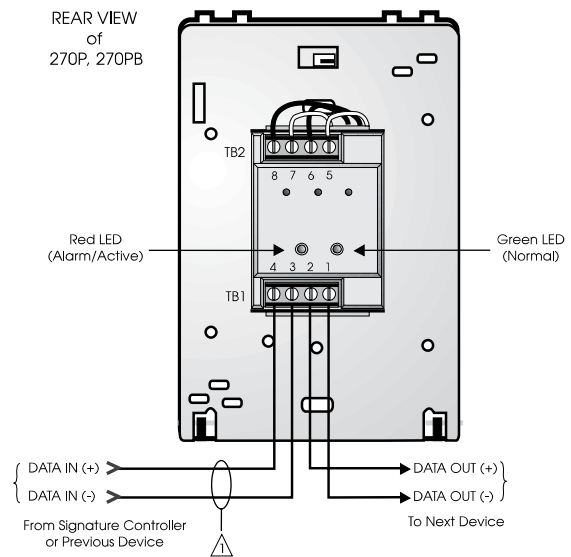

Figure 5. Two Stage Systems

# Installation

**Single-stage** Signature Series fire alarm manual pull stations mount to North American 2½ inch (64 mm) deep 1-gang boxes.

**Two stage** presignal (270P) models require 1½ inch (38 mm) deep 4-inch square boxes with 1-gang, ½-inch raised covers. Openings must be angular. *Rounded openings are not acceptable.* Recommended box: Steel City Model 52-C-13; in Canada, use Iberville Model CI-52-C-49-1/2.

**All models** include terminals are suited for #12 to #18 AWG (2.5 mm<sup>2</sup> to 0.75 mm<sup>2</sup>) wire size. EDWARDS recommends that these fire alarm stations be installed according to latest recognized edition of national and local fire alarm codes.

**Electronic Addressing:** The loop controller electronically addresses each manual station, saving valuable time during system commissioning. Setting complicated switches or dials is not required. Each station has its own unique serial number stored in its on-board memory. The loop controller identifies each device on the loop and assigns a “soft” address to each serial number. If desired, the stations can be addressed using the SIGA-PRO Signature Program/Service Tool.

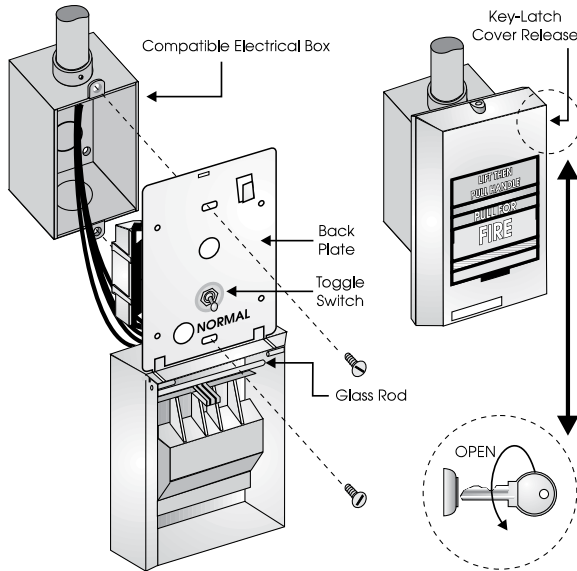

Figure 1. SIGA-278 installation

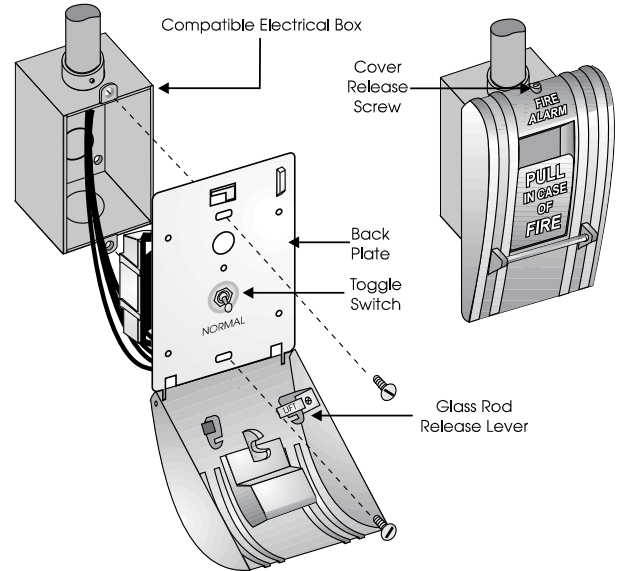

Figure 2. SIGA-270, SIGC-270F, SIGC-270B installation

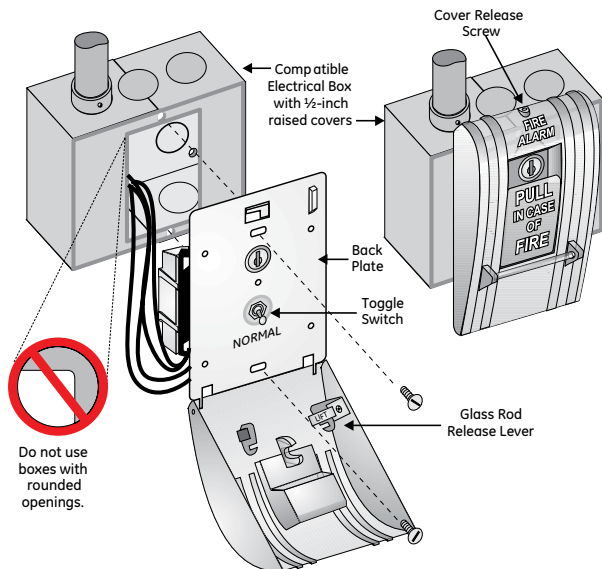

Figure 3. SIGA-270P, SIGC-270PB installation



LIFE SAFETY & INCIDENT MANAGEMENT

**Contact us**

Phone: 800-655-4497 (Option 4)  
 Email: [edwards.fire@carrier.com](mailto:edwards.fire@carrier.com)  
 Website: [edwardsfiresafety.com](http://edwardsfiresafety.com)

8985 Town Center Pkwy  
 Bradenton, FL 34202

© 2020 Carrier  
 All rights reserved.

## Specifications

Catalog Number	SIGA-270, SIGC-270F, SIGC-270B	SIGA-270P, SIGC-270PB	SIGA-278
Description	Single Action - One Stage	Single Action -Two Stage (Presignal)	Double Action - One Stage
Addressing Requirements	Uses 1 Module Address	Uses 2 Module Addresses	Uses 1 Module Address
Operating Current	Standby = 250µA Activated = 400µA	Standby = 396µA Activated = 680µA	Standby = 250µA Activated = 400µA
Construction & Finish	Diecast Zinc - Red Epoxy with aluminum markings		Lexan - Red with white markings
Type Code	Factory Set		
Operating Voltage	15.2 to 19.95 Vdc (19 Vdc nominal)		
Storage and Operating Environment	Operating Temperature: 32°F to 120°F (0°C to 49°C) Storage Temperature: -4°F to 140°F (-20°C to 60°C) Humidity: 0 to 93% RH		
LED Operation	On-board Green LED - Flashes when polled On-board Red LED - Flashes when in alarm		
Compatibility	Use With: Signature Loop Controller		
Agency Listings	UL, ULC (note 1), MEA, CSFM, FM		

**Note:** SIGC-270F, SIGC-270B and SIGC-270PB are ULC listed only. Suffix "F" indicates French markings. Suffix "B" indicates English/French bilingual markings.

## Ordering Information

Catalog Number	Description	Ship Wt. lbs (kg)
SIGA-270	One Stage Fire Alarm Station, English Markings - UL/ULC Listed	
SIGC-270F	One Stage Fire Alarm Station, French Markings - ULC Listed	
SIGC-270B	One Stage Fire Alarm Station, French/English Markings - ULC Listed	
SIGA-270P	Two Stage (Presignal) Fire Alarm Station, English Markings - UL/ULC Listed	1 (0.5)
SIGC-270PB	Two Stage (Presignal) Fire Alarm Station, French/English Markings - ULC Listed	
<b>SIGA-278</b>	<b>Double Action (One Stage) Fire Alarm Station, English Markings - UL/ULC Listed</b>	

### Accessories

32997	GA Key w/Tag - for pre-signal station (CANADA ONLY)	
276-K2	GA Key - for pre-signal station (USA ONLY)	
276-K1	Station Reset Key, Supplied with all Key Reset Stations	0.1 (.05)
27165	12 Glass Rods - for SIGA-270 series (CANADA ONLY)	
270-GLR	20 Glass Rods - for SIGA-270 series (USA ONLY)	
276-GLR	20 Glass Rods - for SIGA-278 series	
276B-RSB	Surface Mount Box, Red - for SIGA pull stations	1 (0.6)

LIFE SAFETY &amp; INCIDENT MANAGEMENT

# Signal Modules

**SIGA-CC1**, SIGA-MCC1,  
SIGA-CC2 & SIGA-MCC2

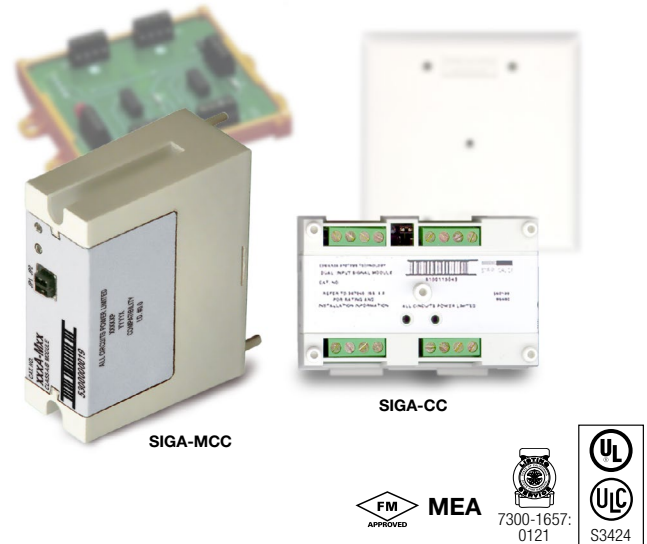

## Overview

SIGA-CC1/MCC1 Single Input Signal Modules and SIGA-CC2/MCC2 Dual Input Signal Modules are part of EDWARDS's Signature Series system. They are intelligent analog addressable devices used for connecting, upon command from the loop controller, supervised Class B signal or telephone circuits to their respective power inputs. The power inputs may be polarized 24 Vdc to operate audible and visible signal appliances or 25 and 70 VRMS to operate audio evacuation speakers and firefighter's telephones.

The actual operation of the SIGA-CC1/MCC1 and SIGA-CC2/MCC2 is determined by the "personality code" selected by the installer. It is downloaded to the module from the Signature loop controller during system configuration.

**The SIGA-CC1 and SIGA-CC2** mount to standard North American two-gang electrical boxes, making them ideal for locations where only one module is required. Separate I/O and data loop connections are made to each module.

**The SIGA-MCC1 and SIGA-MCC2** are part of the UIO family of plug-in Signature Series modules. They function identically to the SIGA-CC1 and SIGA-CC2, but take advantage of the modular flexibility and easy installation that characterize all UIO modules. Two- and six-module UIO motherboards are available. These can accommodate individual risers for each on-board module, or risers that are shared by any combination of its UIO modules. All wiring connections are made to terminal blocks on the motherboard. UIO assemblies may be mounted in EDWARDS enclosures.

## Standard Features

- Single and Dual input (riser) select**  
 Use for connecting supervised 24 Vdc Audible/Visible signal circuits, or 25 and 70 VRMS Audio Evacuation and Telephone circuits to their power inputs.
- Ring-tone generator**  
 When configured for telephone circuits, the SIGA-CC1 generates its own ring-tone signal eliminating the need for a separate ring-tone circuit.
- Plug-in (UIO) or standard 2-gang mount**  
 UIO versions allow quick installation where multiple modules are required. The 2-gang mount version is ideal for remote locations that require a single module.
- Automatic device mapping**  
 Signature modules transmit information to the loop controller regarding their circuit locations with respect to other Signature devices on the wire loop.
- Electronic addressing**  
 Programmable addresses are downloaded from the loop controller, a PC, or the SIGA-PRO Signature Program/Service Tool; there are no switches or dials to set.
- Intelligent device with microprocessor**  
 All decisions are made at the module to allow lower communication speed with substantially improved control panel response time and less sensitivity to line noise and loop wiring properties; twisted or shielded wire is not required.
- Ground fault detection by address**  
 Detects ground faults right down to the device level.

## Installation

**The SIGA-CC1 and SIGA-CC2:** mount to North American 2-1/2 inch (64 mm) deep two-gang boxes and 1-1/2 inch (38 mm) deep 4-inch square boxes with two-gang covers and SIGA-MP mounting plates. The terminals are suited for #12 to #18 AWG (2.5 mm<sup>2</sup> to 0.75 mm<sup>2</sup>) wire size.

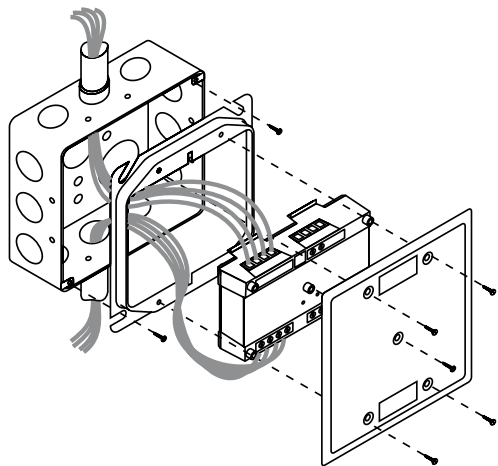

**SIGA-MCC1 and SIGA-MCC2:** mount the UIO motherboard inside a suitable EDWARDS enclosure with screws and washers provided. Plug the SIGA-MCC1 or SIGA-MCC2 into any available position on the motherboard and secure the module to the motherboard with the captive screws. Wiring connections are made to the terminals on the motherboard (see wiring diagram). UIO motherboard terminals are suited for #12 to #18 AWG (2.5 mm<sup>2</sup> to 0.75 mm<sup>2</sup>) wire size.

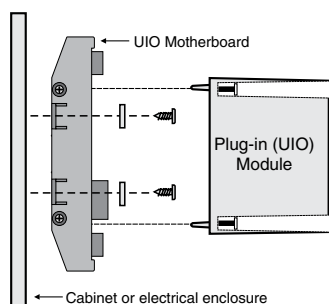

EDWARDS recommends that this module be installed according to latest recognized edition of national and local fire alarm codes.

**Electronic Addressing** - The loop controller electronically addresses each module saving valuable time during system commissioning. Setting complicated switches or dials is not required. Each module has its own unique serial number stored in its on-board memory. The loop controller identifies each device on the loop and assigns a “soft” address to each serial number. If desired, the modules can be addressed using the SIGA-PRO Signature Program/Service Tool.

Personality Codes 5 and 6 apply to the SIGA-CC1/MCC1 only and are assigned by the installer. Code 7 applies to the SIGA-CC2/MCC2 only. It is factory assigned; no user configuration is required.

## Application

The operation of the SIGA-CC1/MCC1 and SIGA-CC2/MCC2 is determined by their sub-type code or “Personality Code”. The code is selected by the installer depending upon the desired application and is down-loaded from the loop controller. Codes 5 and 6 apply to the SIGA-CC1/MCC1 only. Code 7 is assigned to the SIGA-CC2/MCC2 only and automatically applies to both circuits (A and B).

**Personality Code 5: SIGNAL POWER or AUDIO EVACUATION (SINGLE RISER).** Valid for the SIGA-CC1/MCC1 only. Configures the module for use as a Class B Audible/Visible Signal power (24 Vdc polarized) or Audio Evacuation (25 or 70 VRMS) power selector. The ring-tone generator is disabled. The output circuit is monitored for open or shorted wiring. If a short exists, the control panel inhibits the activation of the audible/visible signal circuit to prevent connection to the power circuit.

**Personality Code 6: TELEPHONE w/RING-TONE (SINGLE RISER).** Valid for the SIGA-CC1/MCC1 only. Configures the module for use as a Telephone power selector. When a telephone handset is plugged into its jack or lifted from its hook, the module generates its own Ring-Tone signal. A separate ring-tone circuit is not needed. The module sends this signal to the control panel to indicate that an off-hook condition is present. When the system operator responds to the call, the ring-tone signal is disabled.

**Personality Code 7: SIGNAL POWER or AUDIO EVACUATION (DUAL RISER).** Valid for the SIGA-CC2/MCC2 only. Configures the module for use as a two circuit Class B Audible/Visible Signal power (24 Vdc polarized) or Audio Evacuation (25 or 70 VRMS) power selector. The single output circuit is monitored for open or shorted wiring. If a short exists, the control panel inhibits the activation of the audible/visible signal circuit to prevent connection to the power circuit.

## Warnings & Cautions

This module will not operate without electrical power. As fires frequently cause power interruption, we suggest you discuss further safeguards with your fire protection specialist.

## Compatibility

The Signature Series modules are compatible only with EDWARDS's Signature Loop Controller.

## Testing & Maintenance

The module's automatic self-diagnosis identifies when it is defective and causes a trouble message. The user-friendly maintenance program shows the current state of each module and other pertinent messages. Single modules may be turned off (de-activated) temporarily, from the control panel.

Scheduled maintenance (Regular or Selected) for proper system operation should be planned to meet the requirements of the Authority Having Jurisdiction (AHJ). Refer to current NFPA 72 and ULC CAN/ULC 536 standards.

# Typical Wiring (SIGA-CC2/MCC2)

Modules will accept #18 AWG (0.75mm<sup>2</sup>), #16 (1.0mm<sup>2</sup>), #14 AWG (1.50mm<sup>2</sup>) and #12 AWG (2.5mm<sup>2</sup>) wire sizes.

Note: Sizes #16 AWG (1.0mm<sup>2</sup>) and #18 AWG (0.75mm<sup>2</sup>) are preferred for ease of installation. See Signature Loop Controller catalog sheet for detailed wiring requirement specifications.

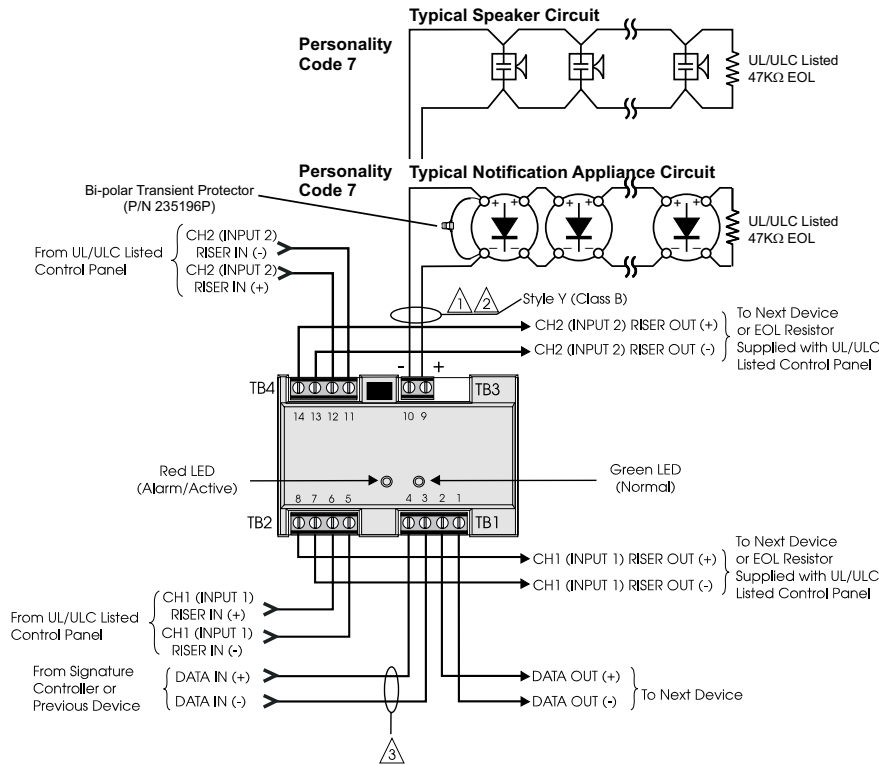

**SIGA-CC2**

## Notes

- 1 For maximum wire resistance and maximum wire distances, refer to IOMC Manual (P/N 270144).
- 2 Maximum #12 AWG (2.5mm<sup>2</sup>) wire. Min. #18 (0.75mm<sup>2</sup>).
- 3 Refer to Signature Loop Controller Installation Sheet for wiring specifications.
- 4 These modules will NOT support two-wire smoke detectors.
- 5 All wiring power limited and supervised. If the input source is non-power limited, then maintain spacing of 1/4 inch or use FPL, FPLP, FPLR or equivalent in accordance with NEC.
- 6 The SIGA-UIO6 does not come with TB8 through TB13.
- 7 Supervised and power-limited.
- 8 Supervised and power-limited when connected to a power-limited source. If the source is nonpower-limited, maintain a space of 1/4 inch from power-limited wiring or use FPL, FPLP, FPLR, or an equivalent in accordance with the National Electrical Code.
- 9 The input for this riser is common to all modules.

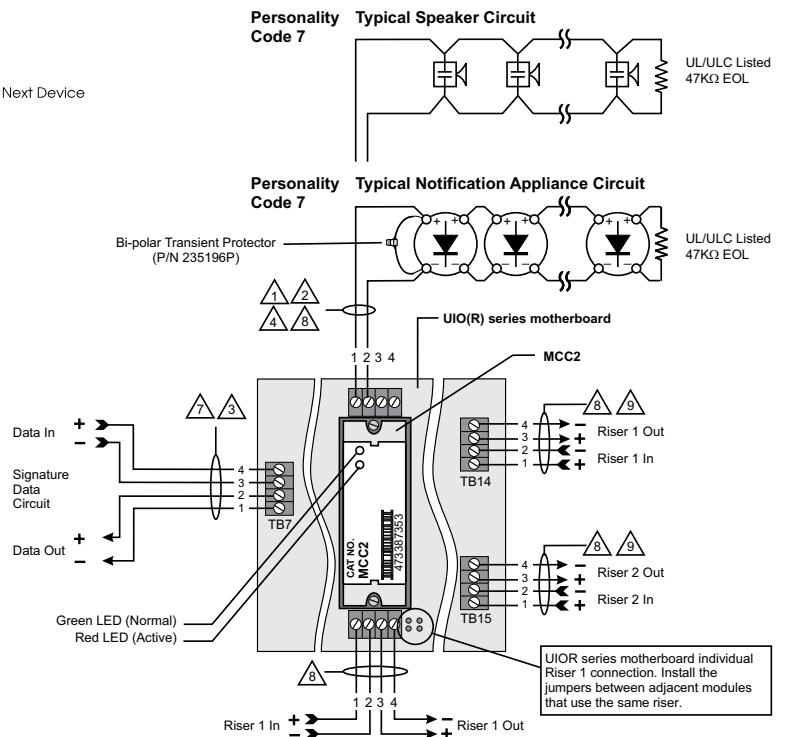

**SIGA-MCC2**

Maximum Output Load		
24Vdc	25V	70V
Signals	Audio	Audio
2A	50W	35W



# Typical Wiring (SIGA-CC1/MCC1)

Modules will accept #18 AWG (0.75mm<sup>2</sup>), #16 (1.0mm<sup>2</sup>), #14 AWG (1.50mm<sup>2</sup>) and #12 (2.5mm<sup>2</sup>) wire sizes.

Note: Sizes #16 AWG (1.0mm<sup>2</sup>) and #18 AWG (0.75mm<sup>2</sup>) are preferred for ease of installation. See Signature Loop Controller catalog sheet for detailed wiring requirement specifications.

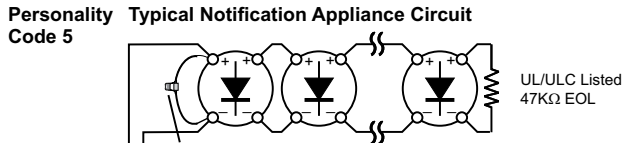
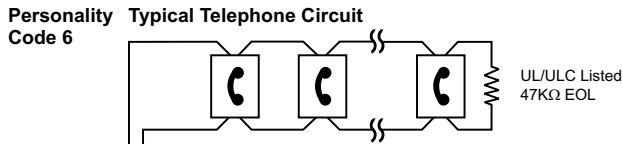
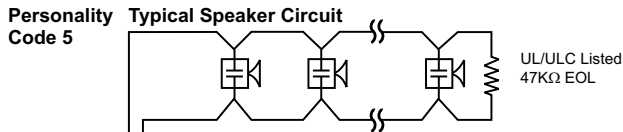

Maximum Output Load		
24Vdc	25V	70V
Signals	Audio	Audio
2A	50W	35W

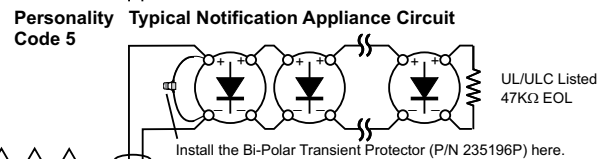
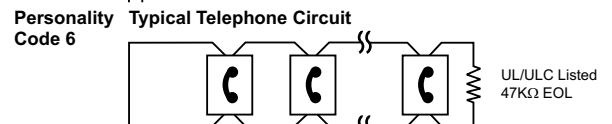
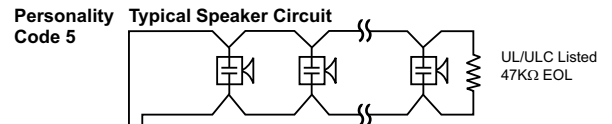
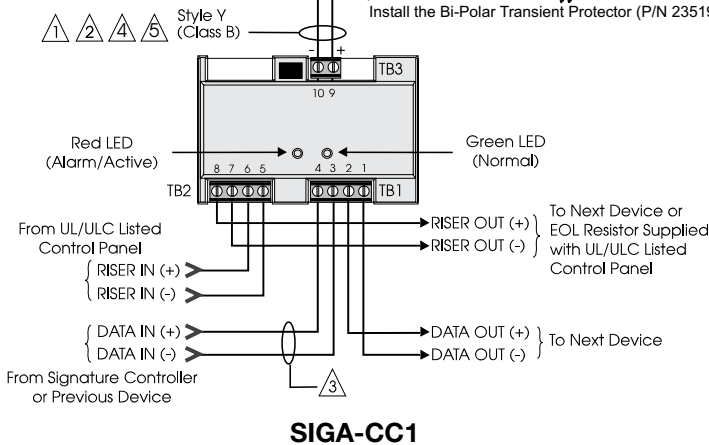

## Notes

- ② Maximum #12 AWG (2.5mm<sup>2</sup>) wire. Min. #18 (0.75mm<sup>2</sup>).
- ③ Refer to Signature Loop Controller Installation Sheet for wiring specifications.
- ④ These modules will NOT support two-wire smoke detectors.
- ⑤ All wiring power limited and supervised. If the input source is non-power limited, then maintain spacing of 1/4 inch or use FPL, FPLP, FPLR or equivalent in accordance with NEC.
- ⑥ The SIGA-UIO6 does not come with TB8 through TB13.
- ⑦ Supervised and power-limited.
- ⑧ If the source is nonpower-limited, maintain a space of 1/4 inch from power-limited wiring or use FPL, FPLP, FPLR, or an equivalent in accordance with the National Electrical Code.
- ⑨ The input for this riser is common to all modules.

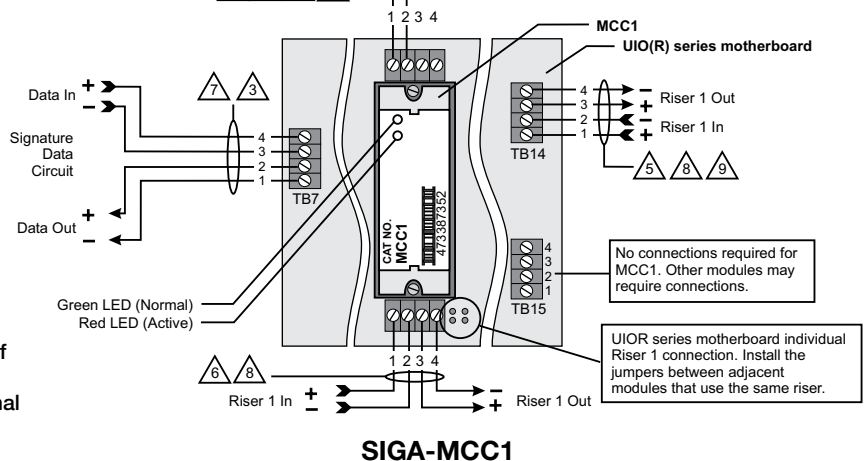

## Signature Series Overview

The Signature Series intelligent analog-addressable system from EDWARDS is an entire family of multi-sensor detectors and mounting bases, multiple-function input and output modules, network and non-network control panels, and user-friendly maintenance and service tools. Analog information from equipment connected to Signature devices is gathered and converted into digital signals. An onboard microprocessor in each Signature device measures and analyzes the signal and decides whether or not to input an alarm. The microprocessor in each Signature device provides four additional benefits – Self-diagnostics and History Log, Automatic Device Mapping, and Fast, Stable Communication.

**Self-diagnostics and History Log** – Each Signature Series device constantly runs self-checks to provide important maintenance information. The results of the self-check are automatically updated and permanently stored in its non-volatile memory. This information is accessible for review any time at the control panel, PC, or using the SIGA-PRO Signature Program/Service Tool. The information stored in device memory includes:

- Device serial number, address, and type
- Time and date of last alarm (EST3 V 2 only.)
- Most recent trouble code logged by the detector — 32 possible trouble codes may be used to diagnose faults.

**Automatic Device Mapping** –The Signature Data Controller (SDC) learns where each device's serial number address is installed relative to other devices on the circuit. The SDC keeps a map of all Signature Series devices connected to it. The Signature Series Data Entry Program also uses the mapping feature. With interactive menus and graphic support, the wired circuits between each device can be examined. Layout or "as-built" drawing information showing branch wiring (T-taps), device types and their address are stored on disk for printing hard copy. This takes the mystery out of the installation. The preparation of as-built drawings is fast and efficient.

Device mapping allows the Signature Data Controller to discover:

- Unexpected additional device addresses
- Missing device addresses
- Changes to the wiring in the circuit.

Most Signature modules use a personality code selected by the installer to determine their actual function. Personality codes are downloaded from the SDC during system configuration and are indicated during device mapping.



LIFE SAFETY & INCIDENT MANAGEMENT

**Contact us**

Phone: 800-655-4497 (Option 4)  
 Email: [edwards.fire@carrier.com](mailto:edwards.fire@carrier.com)  
 Website: [edwardsfiresafety.com](http://edwardsfiresafety.com)

8985 Town Center Pkwy  
 Bradenton, FL 34202

© 2020 Carrier  
 All rights reserved.

## Specifications

Catalog Number	SIGA-CC1	SIGA-MCC1	SIGA-CC2	SIGA-MCC2
Description	Single Input (Riser) Signal Module		Dual Input (Riser) Signal Module	
Type Code	50 (factory set) Two sub-types (personality codes) are available		51 (factory set) One sub-type (personality code) is available (factory set)	
Address Requirements	Uses one module address		Uses two module addresses	
Wiring Terminations	Suitable for #12 to #18 AWG (2.5 mm <sup>2</sup> to 0.75mm <sup>2</sup> )			
Mounting	North American 2½ inch (64 mm) deep two-gang boxes and 1½ inch (38 mm) deep 4 inch square boxes with 2-gang covers and SIGA-MP mounting plates	Plugs into UIO2R, UIO6R or UIO6 Motherboards	North American 2½ inch (64 mm) deep two-gang boxes and 1½ inch (38 mm) deep 4 inch square boxes with 2-gang covers and SIGA-MP mounting plates	Plugs into UIO2R, UIO6R or UIO6 Motherboards
Operating Current	Standby = 223µA Activated = 100µA			
Operating Voltage	15.2 to 19.95 Vdc (19 Vdc nominal)			
Output Rating	24 Vdc = 2 amps 25 V Audio = 50 watts 70 V Audio = 35 watts			
Construction	High Impact Engineering Polymer			
Storage & Operating Environment	Operating Temperature: 32°F to 120°F (0°C to 49°C) Storage Temperature: -4°F to 140°F (-20°C to 60°C) Humidity: 0 to 93% RH			
LED Operation	On-board Green LED - Flashes when polled On-board Red LED - Flashes when in alarm/active			
Compatibility	Use with: Signature Loop Controller			
Agency Listings	UL, ULC, CSFM, MEA, FM			

## Ordering Information

Catalog Number	Description	Ship Wt. lbs (kg)
SIGA-CC1	Single Input Signal Module (Standard Mount) - UL/ULC Listed	0.5 (0.23)
SIGA-MCC1	Single Input Signal Module (UIO Mount) - UL/ULC Listed	0.18 (0.08)
SIGA-CC2	Dual Input Signal Module (Standard Mount) - UL/ULC Listed	0.5 (0.23)
SIGA-MCC2	Dual Input Signal Module (UIO Mount) - UL/ULC Listed	0.18 (0.08)

### Related Equipment

27193-21	Surface Mount Box - Red, 2-gang	2 (1.2)
27193-26	Surface Mount Box - White, 2-gang	2 (1.2)
SIGA-UIO2R	Universal Input-Output Module Board w/Riser Inputs - Two Module Positions	0.32 (0.15)
SIGA-UIO6R	Universal Input-Output Module Board w/Riser Inputs - Six Module Positions	0.62 (0.28)
SIGA-UIO6	Universal Input-Output Module Board - Six Module Positions	0.56 (0.25)
235196P	Bi-polar Transient Protector	0.01 (0.05)

### Accessories

MFC-A	Multifunction Fire Cabinet - Red, supports Signature Module Mounting Plates	7.0 (3.1)
SIGA-MP1	Signature Module Mounting Plate, 1 footprint	1.5 (0.70)
SIGA-MP2	Signature Module Mounting Plate, 1/2 footprint	0.5 (0.23)
SIGA-MP2L	Signature Module Mounting Plate, 1/2 extended footprint	1.02 (0.46)

LIFE SAFETY &amp; INCIDENT MANAGEMENT

# Control Relay Modules

**SIGA-CR**, SIGA-MCR, SIGA-CRR, SIGA-MCRR

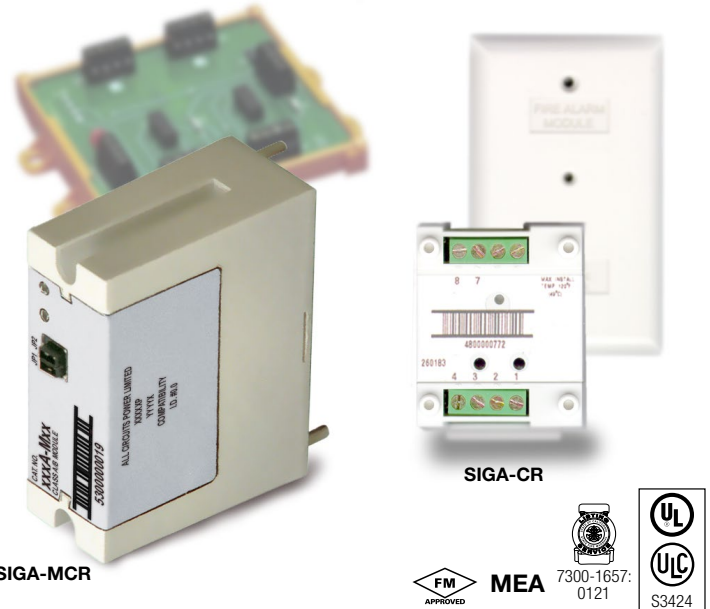

## Overview

The Control Relay Module and the Polarity Reversal Relay Module are part of the Signature Series system. They are intelligent analog addressable devices available in either plug-in (UIO) versions, or standard 1-gang mount versions.

**The SIGA-CR/MCR** Control Relay Module provides a Form “C” dry relay contact to control external appliances such as door closers, fans, dampers etc. This device does not provide supervision of the state of the relay contact. Instead, the on-board microprocessor ensures that the relay is in the proper ON/OFF state. Upon command from the loop controller, the SIGA-CR/MCR relay activates the normally open or normally-closed contact.

**The SIGA-CRR/MCRR** Polarity Reversal Relay Module provides a Form “C” dry relay contact to power and activate a series of SIGA-AB4G Audible Sounder Bases. Upon command from the Signature loop controller, the SIGA-CRR reverses the polarity of its 24 Vdc output, thus activating all Sounder Bases on the data loop.

**Standard-mount versions (SIGA-CR and SIGA-CRR)** are installed to standard North American 1-gang electrical boxes, making them ideal for locations where only one module is required. Separate I/O and data loop connections are made to each module.

**Plug-in UIO versions (SIGA-MCR and SIGA-MCRR)** are part of the UIO family of plug-in Signature Series modules. They function identically to the standard mount versions, but take advantage of the modular flexibility and easy installation that characterizes all UIO modules. Two- and six-module UIO motherboards are available. All wiring connections are made to terminal blocks on the motherboard. UIO assemblies may be mounted in EDWARDS enclosures.

## Standard Features

- Provides one no/nc contact (SIGA-CR/MCR)**  
 Form “C” dry relay contact can be used to control external appliances such as door closers, fans, dampers etc.
- Allows group operation of sounder bases**  
 The SIGA-CRR/MCRR reverses the polarity of its 24 Vdc output, thus activating all Sounder Bases on the data loop.
- Plug-in (UIO) or standard 1-gang mount**  
 UIO versions allow quick installation where multiple modules are required. The 1-gang mount version is ideal for remote locations that require a single module.
- Automatic device mapping**  
 Signature modules transmit information to the loop controller regarding their circuit locations with respect to other Signature devices on the wire loop.
- Electronic addressing**  
 Programmable addresses are downloaded from the loop controller, a PC, or the SIGA-PRO Signature Program/Service Tool; there are no switches or dials to set.
- Intelligent device with microprocessor**  
 All decisions are made at the module to allow lower communication speed with substantially improved control panel response time and less sensitivity to line noise and loop wiring properties; twisted or shielded wire is not required.

## Installation

**SIGA-CR and SIGA-CRR:** modules mount to North American 2½ inch (64 mm) deep 1-gang boxes and 1½ inch (38 mm) deep 4 inch square boxes with 1-gang covers and SIGA-MP mounting plates. The terminals are suited for #12 to #18 AWG (2.5 mm<sup>2</sup> to 0.75 mm<sup>2</sup>) wire size.

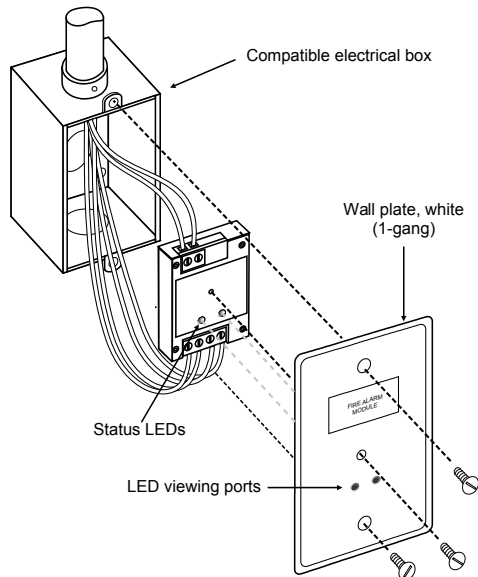

**SIGA-MCR and SIGA-MCRR:** mount the UIO motherboard inside a suitable EDWARDS enclosure with screws and washers provided. Plug the module into any available position on the motherboard and secure the module to the motherboard with the captive screws. Wiring connections are made to the terminals on the motherboard (see wiring diagram). UIO motherboard terminals are suited for #12 to #18 AWG (2.5 mm<sup>2</sup> to 0.75 mm<sup>2</sup>) wire size.

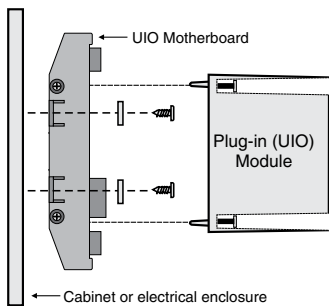

**Electronic Addressing** - The loop controller electronically addresses each module, saving valuable time during system commissioning. Setting complicated switches or dials is not required. Each module has its own unique serial number stored in its on-board memory. The loop controller identifies each device on the loop and assigns a “soft” address to each serial number. If desired, the modules can be addressed using the SIGA-PRO Signature Program/Service Tool.

EDWARDS recommends that this module be installed according to latest recognized edition of national and local fire alarm codes.

## Application

The operation of Signature Series control relays is determined by their sub-type code or “Personality Code.”

### Personality Code 8: CONTROL RELAY (SIGA-CR/MCR)

**- Dry Contact Output.** This setting configures the module to provide one Form “C” DRY RELAY CONTACT to control Door Closers, Fans, Dampers, etc. Contact rating is 2.0 amp @ 24 Vdc; 0.5 amp @ 120 Vac (or 0.25A @ 220 Vac for non-UL applications). Personality Code 8 is assigned at the factory. No user configuration is required.

### Personality Code 8: POLARITY REVERSAL RELAY MODULE (SIGA-CRR/MCRR)

This setting configures the module to reverse the polarity of its 24 Vdc output. Contact rating is 2.0 amp @ 24 Vdc (pilot duty). Personality Code 8 is assigned at the factory. No user configuration is required.

## Compatibility

These modules are part of EDWARDS’s Signature Series intelligent processing and control platform. They are compatible with EST3, EST3X and iO Series control panels.

## Warnings & Cautions

This module will not operate without electrical power. As fires frequently cause power interruption, we suggest you discuss further safeguards with your local fire protection specialist.

## Testing & Maintenance

The module’s automatic self-diagnosis identifies when it is defective and causes a trouble message. The user-friendly maintenance program shows the current state of each module and other pertinent messages. Single modules may be turned off (deactivated) temporarily, from the control panel. Availability of maintenance features is dependent on the fire alarm system used. Scheduled maintenance (Regular or Selected) for proper system operation should be planned to meet the requirements of the Authority Having Jurisdiction (AHJ). Refer to current NFPA 72 and ULC CAN/ULC 536 standards.

## Typical Wiring

Modules will accept #18 AWG (0.75mm<sup>2</sup>), #16 (1.0mm<sup>2</sup>), #14 AWG (1.50mm<sup>2</sup>) and #12 AWG (2.5mm<sup>2</sup>) wire sizes.

Note: Sizes #16 AWG (1.0mm<sup>2</sup>) and #18 AWG (0.75mm<sup>2</sup>) are preferred for ease of installation. See Signature Loop Controller catalog sheet for detailed wiring requirement specifications.

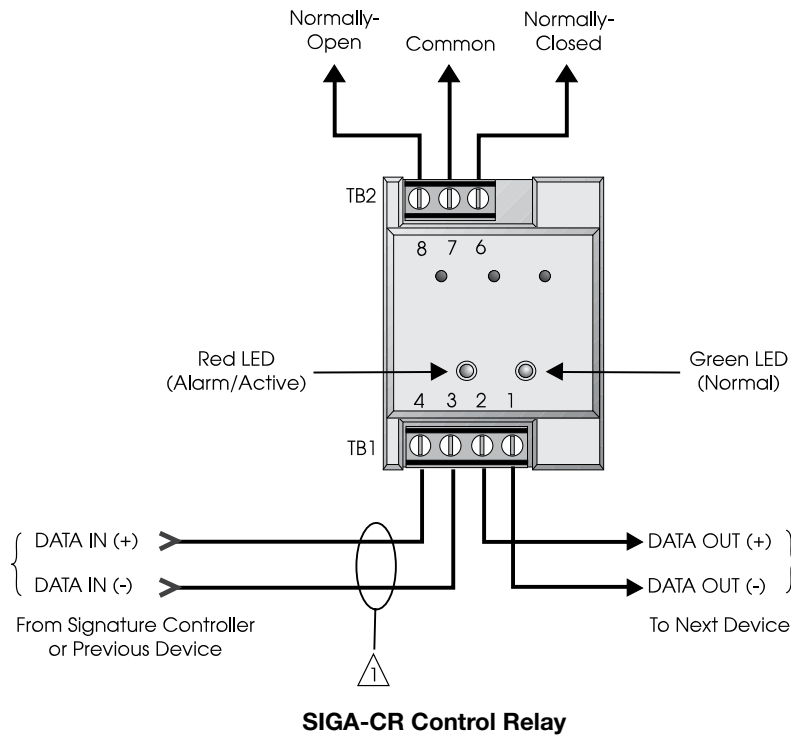

### Notes

- 1 Refer to Signature Loop Controller Installation Sheet for wiring specifications.
- 2 NFPA 72 requires that the SIGA-CR/SIGA-MCR be installed in the same room as the device it is controlling. This requirement may not apply in all markets. Check with your local AHJ for details.
- 3 The SIGA-UIO6R and the SIGA-UIO2R do not come with TB14.
- 4 The SIGA-UIO6 does not come with TB8 through TB13.
- 5 Supervised and power-limited.
- 6 If the source is nonpower-limited, maintain a space of 1/4 inch from power-limited wiring or use FPL, FPLP, FPLR, or an equivalent in accordance with the National Electrical Code.
- 7 Maximum #12 AWG (2.5mm<sup>2</sup>) wire. Min. #18 (0.75mm<sup>2</sup>).

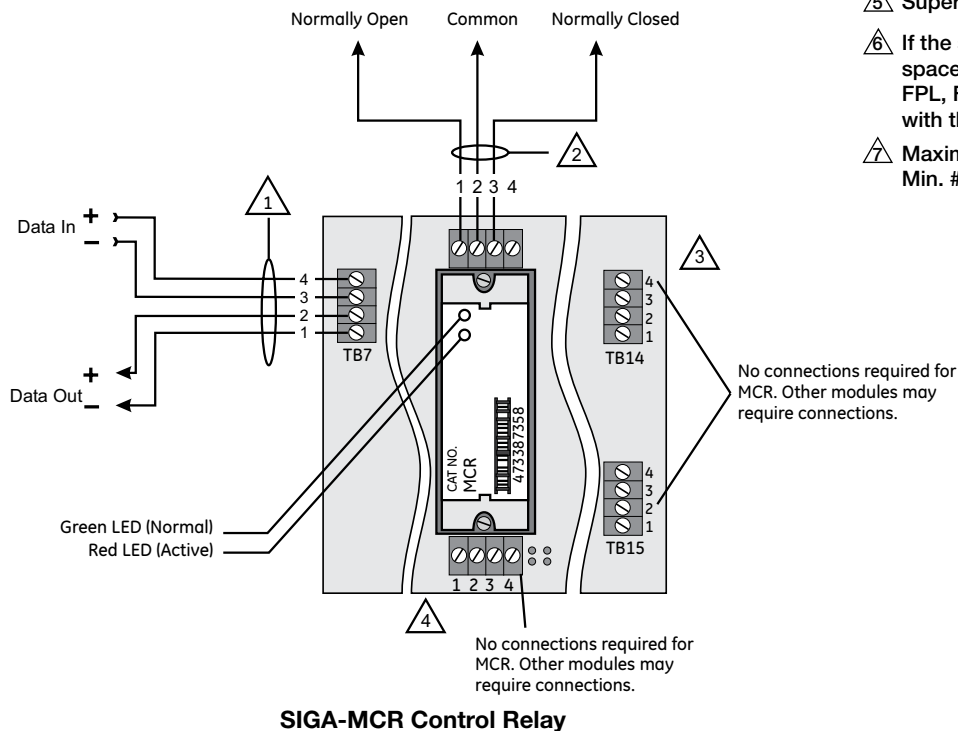

# Typical Wiring

Modules will accept #18 AWG (0.75mm<sup>2</sup>), #16 (1.0mm<sup>2</sup>), #14 AWG (1.50mm<sup>2</sup>) and #12 AWG (2.50mm<sup>2</sup>) wire sizes.

Note: Sizes #16 AWG (1.0mm<sup>2</sup>) and #18 AWG (0.75mm<sup>2</sup>) are preferred for ease of installation. See Signature Loop Controller catalog sheet for detailed wiring requirement specifications.

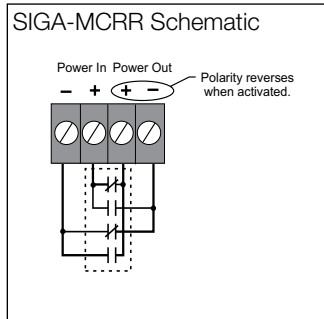
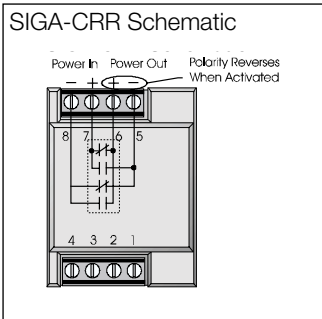
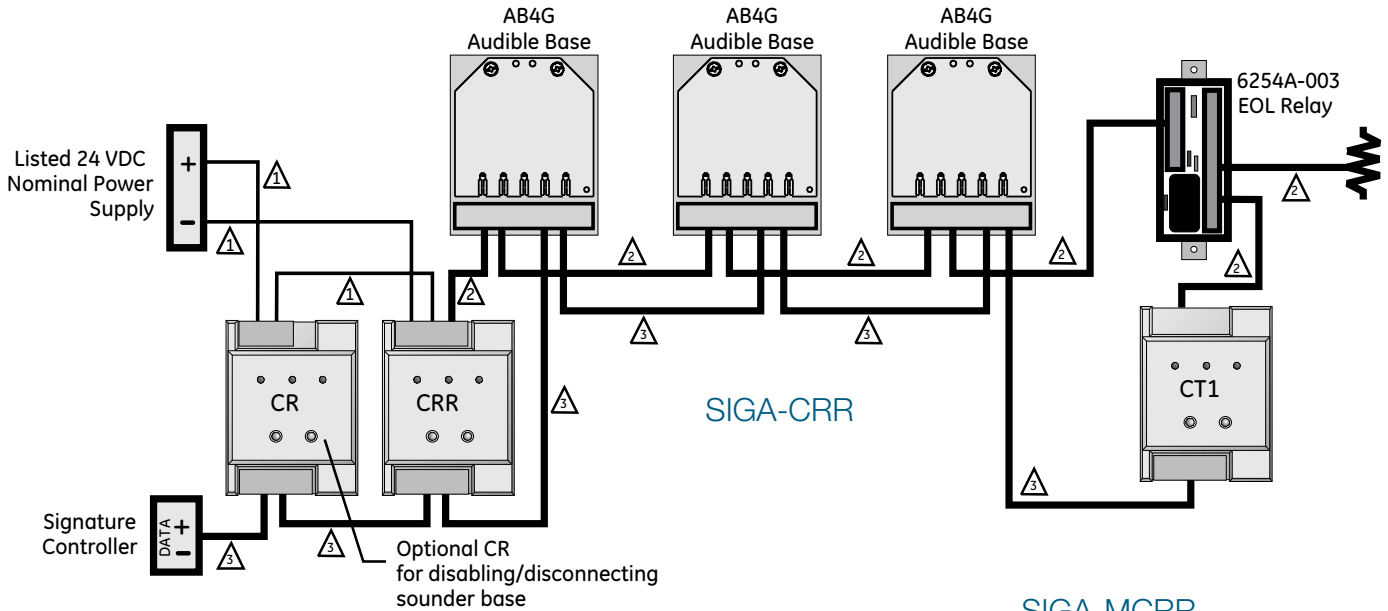

## SIGA-MCRR

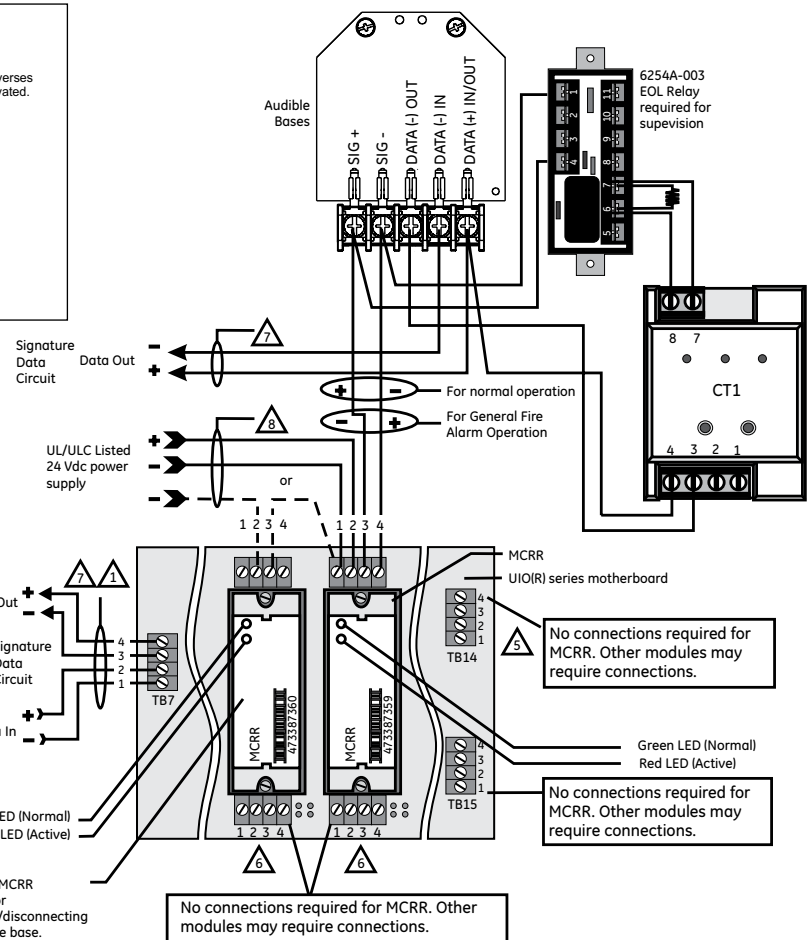

### Notes

- ⚠ Refer to the Signature controller installation sheet for wiring.
- ⚡ One Pair of Wires (24 Vdc power).
- ⚡ One Pair of Wires (Signature Data).
- ⚡ Single Wire (24 Vdc power).
- ⚠ The SIGA-UIO6R and the SIGA-UIO2R do not come with TB14.
- ⚠ The SIGA-UIO6 does not come with TB8 through TB13.
- ⚠ Supervised and power-limited.
- ⚠ If the source is nonpower-limited, maintain a space of 1/4 inch from power-limited wiring or use FPL, FPLP, FPLR, or an equivalent in accordance with the National Electrical Code.
- 9 Maximum #12 AWG (2.5 mm<sup>2</sup>) wire; Minimum #18 AWG (0.75 mm<sup>2</sup>).
- 10 End-of-Line Relay must monitor and report power supply trouble to control panel.
- 11 Class B Data wiring may be "T-tapped."

# Specifications

Catalog Number	SIGA-CR	SIGA-MCR	SIGA-CRR	SIGA-MCRR
Description	Control Relay		Polarity Reversal Relay	
Type Code	Personality Code 8 (Factory Set)		Personality Code 8 (Factory Set)	
Address Requirements	Uses 1 Module Address			
Operating Current	Standby = 75 $\mu$ A Activated = 75 $\mu$ A			
Operating Voltage	15.2 to 19.95 Vdc (19 Vdc nominal)			
Relay Type and Rating	Form C, 2 Amps @ 24 Vdc (pilot duty), 0.5 Amps @ 120 Vac and 0.25 Amps @ 220 Vac (220 Vac is non-UL) Not rated for capacitive loads.			
Mounting	North American 2½ inch (64 mm) deep 1-gang boxes and 1½ inch (38 mm) deep 4 inch square boxes with 1-gang covers and SIGA-MP mounting plates	Plugs into UIO2R, UIO6R or UIO6 Motherboards	North American 2½ inch (64 mm) deep 1-gang boxes and 1½ inch (38 mm) deep 4 inch square boxes with 1-gang covers and SIGA-MP mounting plates	Plugs into UIO2R, UIO6R or UIO6 Motherboards
Construction & Finish	High Impact Engineering Polymer			
Storage and Operating Environment	Operating Temperature: 32°F to 120°F (0°C to 49°C) Storage Temperature: -4°F to 140°F (-20°C to 60°C) Humidity: 0 to 93% RH			
LED Operation	On-board Green LED - Flashes when polled On-board Red LED - Flashes when in alarm/active			
Compatibility	Use With: Signature Loop Controller			
Agency Listings	UL, ULC, CSFM, MEA			

# Ordering Information

Catalog Number	Description	Ship Weight - lbs (kg)
SIGA-CR	Control Relay Module (Standard Mount)	0.4 (0.15)
SIGA-MCR	Control Relay Module (UIO Mount)	0.18 (0.08)
SIGA-CRR	Polarity Reversal Relay Module (Standard Mount)	0.4 (0.15)
SIGA-MCRR	Polarity Reversal Relay Module (UIO Mount)	0.18 (0.08)

Related Equipment		
27193-11	Surface Mount Box - Red, 1-gang	1 (0.6)
27193-16	Surface Mount Box - White, 1-gang	1 (0.6)
SIGA-UIO2R	Universal Input-Output Module Board w/Riser Inputs - Two Module Positions	0.32 (0.15)
SIGA-UIO6R	Universal Input-Output Module Board w/Riser Inputs - Six Module Positions	0.62 (0.28)
SIGA-UIO6	Universal Input-Output Module Board - Six Module Positions	0.56 (0.25)
SIGA-AB4G	Audible (Sounder) Detector Base	0.3 (0.15)

Accessories		
MFC-A	Multifunction Fire Cabinet - Red, supports Signature Module Mounting Plates	7.0 (3.1)
SIGA-MB4	Transponder Mounting Bracket (allows for mounting two 1-gang modules in a 2-gang box)	0.4 (0.15)
SIGA-MP1	Signature Module Mounting Plate, 1 footprint	1.5 (0.70)
SIGA-MP2	Signature Module Mounting Plate, 1/2 footprint	0.5 (0.23)
SIGA-MP2L	Signature Module Mounting Plate, 1/2 extended footprint	1.02 (0.46)





LIFE SAFETY & INCIDENT MANAGEMENT

**Contact us**

Phone: 800-655-4497 (Option 4)  
Email: [edwards.fire@carrier.com](mailto:edwards.fire@carrier.com)  
Website: [edwardsfiresafety.com](http://edwardsfiresafety.com)

8985 Town Center Pkwy  
Bradenton, FL 34202

© 2020 Carrier  
All rights reserved.

---

## Signature Series Overview

The Signature Series intelligent analog-addressable system from EDWARDS is an entire family of multi-sensor detectors and mounting bases, multiple-function input and output modules, network and non-network control panels, and user-friendly maintenance and service tools. Analog information from equipment connected to Signature devices is gathered and converted into digital signals. An onboard microprocessor in each Signature device measures and analyzes the signal and decides whether or not to input an alarm. The microprocessor in each Signature device provides four additional benefits – Self-diagnostics and History Log, Automatic Device Mapping, and Fast, Stable Communication.

**Self-diagnostics and History Log** – Each Signature Series device constantly runs self-checks to provide important maintenance information. The results of the self-check are automatically updated and permanently stored in its non-volatile memory. This information is accessible for review any time at the control panel, PC, or using the SIGA-PRO Signature Program/Service Tool. The information stored in device memory includes:

- Device serial number, address, and type
- Time and date of last alarm
- Most recent trouble code logged by the detector — 32 possible trouble codes may be used to diagnose faults.

**Automatic Device Mapping** –The Signature Data Controller (SDC) learns where each device's serial number address is installed relative to other devices on the circuit. The SDC keeps a map of all Signature Series devices connected to it. The Signature Series Data Entry Program also uses the mapping feature. With interactive menus and graphic support, the wired circuits between each device can be examined. Layout or “as-built” drawing information showing branch wiring (T-taps), device types and their address are stored on disk for printing hard copy. This takes the mystery out of the installation. The preparation of as-built drawings is fast and efficient.

Device mapping allows the Signature Data Controller to discover:

- Unexpected additional device addresses
- Missing device addresses
- Changes to the wiring in the circuit.

Most Signature modules use a personality code selected by the installer to determine their actual function. Personality codes are downloaded from the SDC during system configuration and are indicated during device mapping.



LIFE SAFETY &amp; INCIDENT MANAGEMENT

# Wall Mount Speakers and Speaker-Strobes

## Genesis LED G4S Series

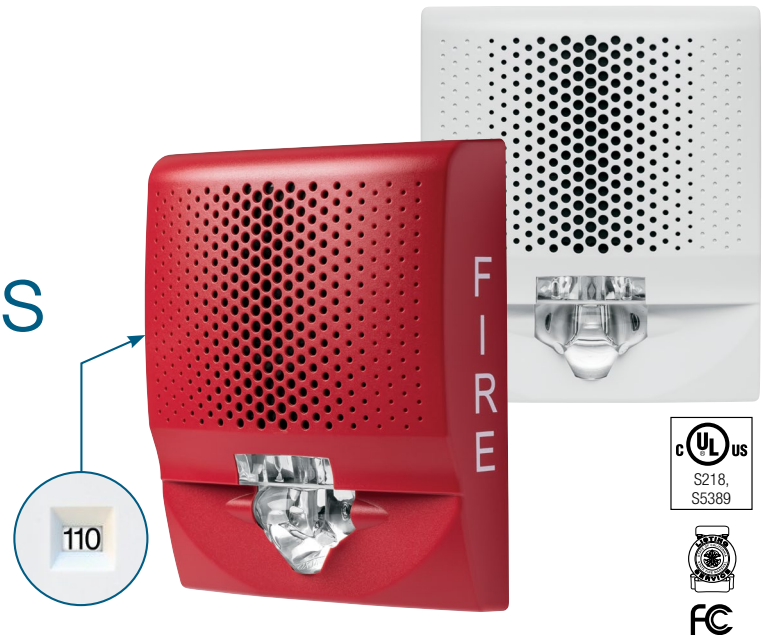

### Overview

Genesis LED G4S Series speakers and speaker-strobes combine high performance output with a sleek low profile design and energy-efficient technology that makes them less expensive to install and operate. High performance LEDs require fewer power supplies, backup power, and batteries. These new appliances are designed with energy-efficiency, and life safety in mind.

Speakers feature selectable wattage taps, while speaker-strobes allow for both wattage and light output levels to be configured in the field. Both settings remain clearly visible — even after final installation. Speakers are also capable of both 25V and 70V and voltage in a single model with a field selectable switch. All this flexibility allows devices to be easily fine-tuned to exactly how they're needed to perform. All Genesis speakers include a DC blocking capacitor to allow electrical supervision of the audio distribution circuit.

Genesis LED G4S Series uses high efficiency optics, combined with patented electronics, to deliver a highly controlled and efficiently focused light distribution pattern in exchange for lower current requirements. Strobes feature field-selectable 15, 30, 75, or 110 cd light output.

Compared with Xenon-type strobes, Genesis LED G4S Series appliances offer greatly reduced current draw which provides benefits in longer circuit lengths, more devices per circuit, smaller wire gauge and reduced power supply quantities for an installation. They are also backwards compatible with legacy strobes, so there's no need to replace all your existing devices to upgrade to

new LED technology. In fact, G4S strobes can be mixed on the same circuit and used in the same field of view as Xenon-based strobes. This makes Genesis LED G4S Series ideal for new installations and retrofits alike.

Field-configurable sound output levels provide the flexibility modern life safety projects demand, while the Genesis LED control protocol keeps multiple strobes on compatible NAC circuits synchronized to well within NFPA 72 requirements. They also meet NFPA and UL 520Hz requirements for sleeping areas making them ideal for new construction or retrofits.

G4S Series speakers produce crisp, clear voice audio output that is highly intelligible over large areas. In an emergency, intelligibility is critical to life safety. Understanding the content of the message is as important as knowing there is an emergency. Intelligibility is measured in Speech Transmission Index and anything above .76 is considered excellent. G4S Series speakers deliver audio with an STI of .81 ensuring the message is clear.

Serviceability is another area where G4S Series appliances shine. The universal room side wiring plate allows for pre-installation and electrical wiring as well as checking continuity with the included diagnostics check bar. G4S Series devices can then be easily snapped into place with the confidence of knowing the wiring is correct. The innovative under-cover diagnostic test points provide easy access to device circuit testing while mounted.

## Standard Features

- **High Fidelity performance with excellent STI**
  - Increased sound fidelity and audio intelligibility with an STI rating of .81 (More than .76 is excellent)
- **Low Frequency (520Hz) capable**
  - Low frequency output meets NFPA standards for newly constructed commercial sleeping areas
- **High Performance LED Strobe Technology**
  - Ultra low device current consumption allows:
    - More devices per circuit
    - Ability to use lower gauge wire
    - Longer wire runs
    - Fewer booster power supplies
  - High efficiency optics
  - Selectable 15, 30, 75, or 110 cd light output
  - LED devices may be mixed with legacy Xenon strobes on the same circuit and in the same field of view
- **Field flexibility**
  - Speakers are also capable of both 25V and 70V and voltage in a single model with a field selectable switch
  - Speakers feature selectable wattage taps for ¼W, ½W, 1W, and 2W to configure sound output levels in the field
- **Low-profile Design**
  - Ultra-slim... protrudes about 1.5" from the mounting surface
  - Attractive appearance... no visible mounting screws
- **Multiple "FIRE" Marking Options**
  - Order English, French, Spanish or no FIRE markings
  - Change markings at any time with replaceable quick-swap covers
- **Easy to Install**
  - Pre-install and pre-wire with convenient universal room side wiring plate
  - Check electrical continuity on room side wiring plate with included diagnostics check bar
  - Diagnostics port streamlines device circuit testing
  - Fits 2-gang and 4-inch square electrical boxes
  - Optional red and white trim plates available
  - Slide switches for field configuration
  - 12 to 18 AWG in-out screw terminals for quick wiring
- **Current draw is the same for all candela output settings**
  - Easier for new system design
  - Flexible for future changes in light output needs

## Application

### Strobes

Genesis G4S Series strobes are UL 1971-listed for use indoors as wall-mounted public-mode notification appliances for the hearing impaired. Prevailing codes require strobes to be used where ambient noise conditions exceed 105 dBA (87 dBA in Canada), where occupants use hearing protection, and in areas of public accommodation as defined in the *Americans with Disabilities Act*.

Synchronization is important in order to avoid triggering seizures in people with photosensitive epilepsy. All Genesis strobes exceed UL synchronization requirements (within 10 milliseconds over a two-hour period) when used with a synchronization source. See the specifications table for a list of compatible sources.

### Speakers

The suggested sound pressure level for each signaling zone used with alert or alarm signals is a minimum of 15 dB above the average ambient sound level or 5 dB above the maximum sound level having a duration of at least 60 seconds, whichever is greater. This is measured 5 feet (1.5 m) above the floor.

Doubling the distance from the signal to the ear will theoretically cause a 6 dB reduction in the received sound pressure level. The actual effect depends on the acoustic properties of materials in the space. Doubling the power output of a device (e.g.: a speaker from 1W to 2W) will increase the sound pressure level by 3dB.

### High Fidelity Sound

Genesis LED G4S Series High Fidelity appliances feature 87dB of sound output along with a highly intelligible Speech Transmission Index (STI) rating of .81. An STI rating above .76 is considered excellent for speech intelligibility. They are also effective in areas subject to high levels of ambient noise.

These appliances are ideal for hotels, dormitories and other residential occupancies that have sleeping areas that require 520Hz tones. In sleeping areas, always ensure that the wattage tap of the speaker is set sufficiently high so that the sound pressure reaches at least 75 dBA at the pillow.

These appliances are part of an end-to-end audio system approved for use in sleeping areas when used in conjunction with approved audio hardware and a factory-supplied 520 Hz tone. Check the System Compatibility List for other 520 Hz signaling requirements.

## Installation

Genesis G4S speakers and speaker-strobes mount to the required GRSW room side wiring plate. The GRSW mounting plate is ordered separately from the G4S device in packs of 10 (GRSW-10) for convenient pre-installing and pre-wiring. The device can be removed easily from the room side wiring plate by pushing up with a screwdriver. The cover can also be removed from the device easily with a screwdriver to access the light and sound output settings and a diagnostics test port for voltage testing.

Genesis LED G4S Series speakers and speaker-strobes mount to any standard two-gang and 4-inch square electrical box. Matching optional G4T trim rings are available to cover oversized openings. Optional color matched double-gang surface boxes are also available.

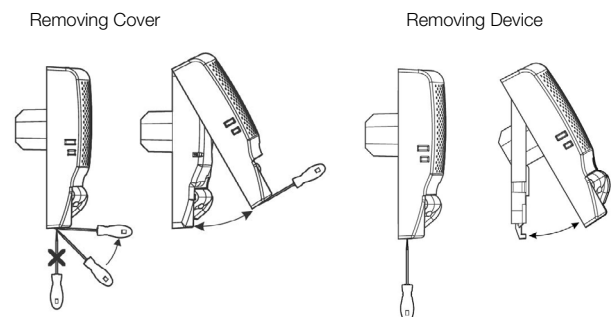

# Installation

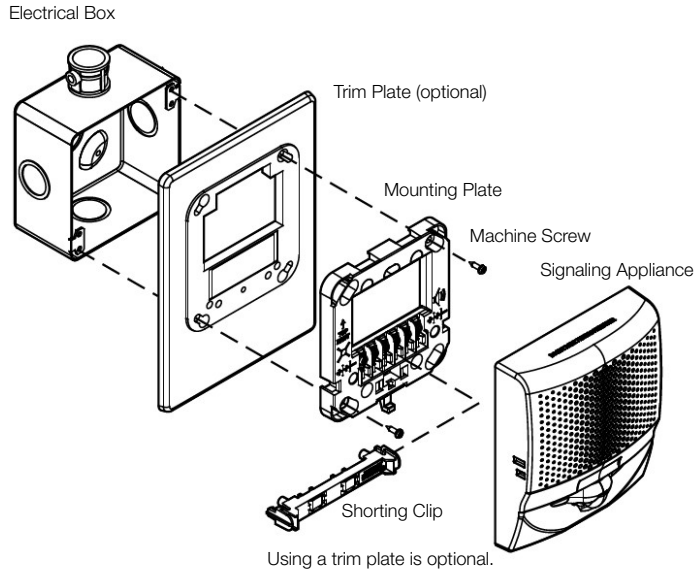

# Dimensions

## G4S Notification Appliances

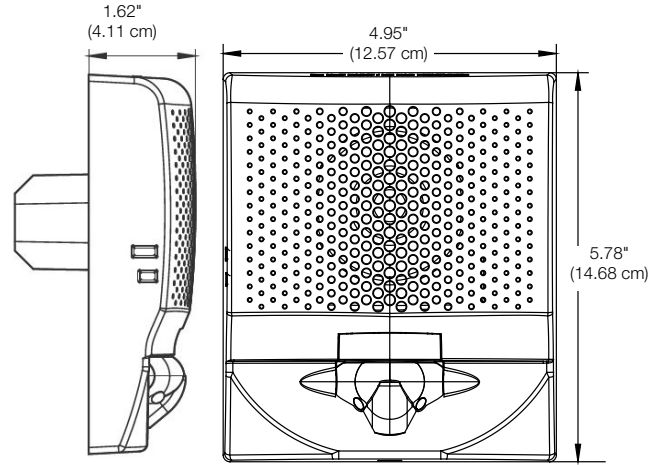

## G4T Trim Plate (optional)

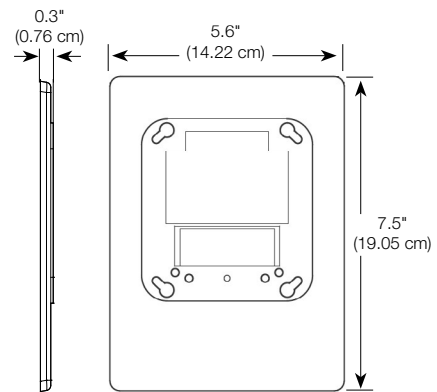

# Wiring

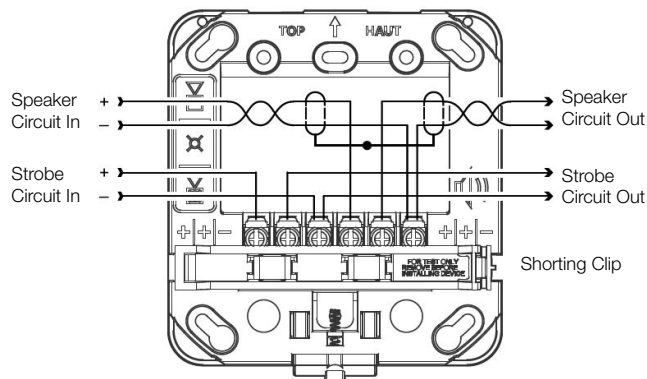

# Diagnostics

## Strobe Circuit Test Points

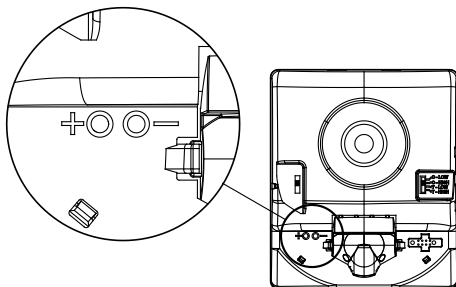

## Speaker Circuit Test Points

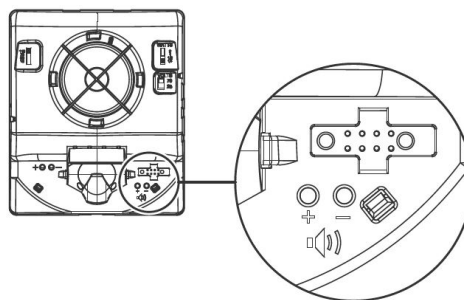

Test points indicated above are used to validate the Notification Appliance Circuit and verify device function.

## Field Configuration

Genesis LED speakers are capable of both 25V and 70V operation depending on the system. The voltage is set via a switch under the cover. Speakers also may be set for ¼, ½, 1, or 2 watt operation. The wattage setting is visible through a small window on the side of the device and is changed by simply sliding the switch under the cover until the desired setting appears in the window. The speaker does not have to be removed to change the wattage, only the cover skin.

Genesis LED clear strobes and speaker-strobes may be set for 15, 30, 75, or 110 candela output. The output setting is changed by simply removing the cover and sliding the candela switch to the desired setting. The device does not have to be removed from the wall to change the output setting. The setting remains visible through a small window on the left-hand side of the device after the cover is closed.

## Light and Sound Output Settings

### Light Output Setting (Candela)

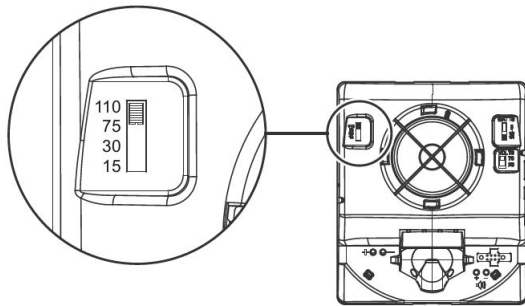

### Sound Settings (Watts and Volts)

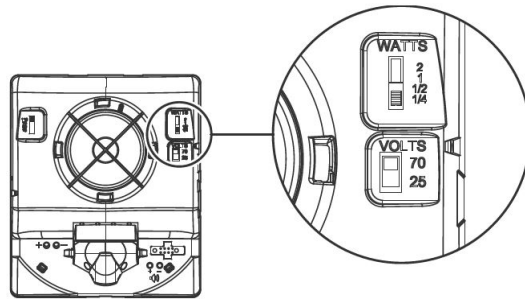

## Operating current

### Strobes

Strobe setting	16 to 33 VDC	16 to 33 VFWR
15, 30, 75, 110	28 mA	36 mA

Note: Current draw is the same for all candela settings

### Sound Level Output

Voltage setting	Wattage setting	Reverberant (UL 1480)	Anechoic (CAN/ULC-S541)
25V / 70V	¼W	78	78
	½W	81	81
	1W	84	84
	2W	87	87

## Sound Output

### Sound pattern (ULC)

Axis	Angle	Change in output
Horizontal	117° and 61°	-3 dBA
	134° and 49°	-6 dBA
Vertical	128° and 68°	-3 dBA
	138° and 52°	-6 dBA

## Light Distribution

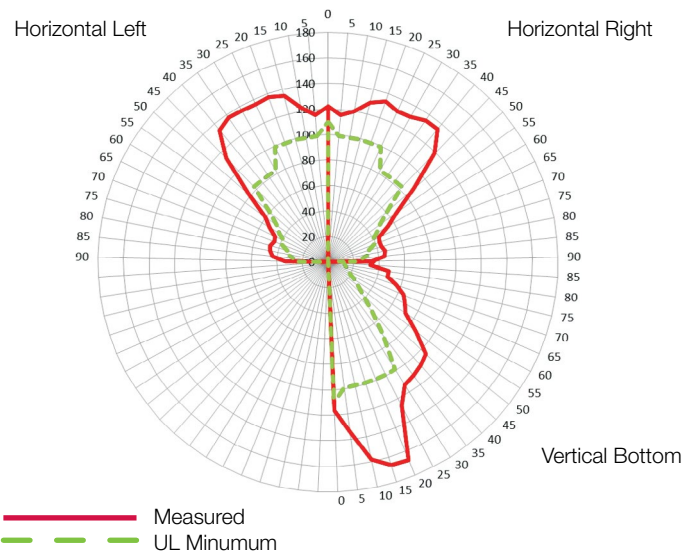

## Specifications

Strobe operating voltage	16 to 33 VDC, 16 to 33 VFWR
Speaker operating voltage	25VRMS of 70VRMS (selectable)
Speaker frequency response	400Hz-4,000Hz
Light output	15, 30, 75, or 110 candela
Strobe flash rate	1 fps (flash per second) approx.
Synchronization	20 Ω max. between any two devices. To determine allowed wire resistance, refer to these specifications, and the specifications for the synchronized signal source.
Synchronization Sources	Edwards CC Series Signal Modules, Booster and Auxiliary Power Supplies, Intelligent and Conventional Control Panels
Wire size	12 to 18 AWG (0.75 to 2.50 mm <sup>2</sup> )
Dimensions (W×H×D)	4.95 x 5.78 x 1.62 in (12.57 x 14.68 x 4.11 cm)
Strobe-to-box center offset	-1.70 inches (-4.32 cm)
Compatible electrical boxes [1]	2-gang, 4-inch square
Trim plates	G4TR, G4TW (5.6 x 7.5 x 0.3 in (14.22 x 19.05 x 0.76 cm))
Operating environment	
Temperature	32 to 122°F (0 to 50°C)
Relative humidity	0 to 93% noncondensing
Storage Temperature	-40 to 158 F (-40 to 70 C)
RAL Color	Red=RAL 3013 White=RAL 9002

[1] Electrical boxes must be at least 1-1/2 in. (3.81 cm) deep.

[2] Recommend electrical boxes be mounted at 81 inches AFF

# Ordering Information

FOR REFERENCE ONLY

Notification Appliances	Color	Marking	
 <b>Speakers</b>	G4SRF	Red	FIRE
	G4SRF-FR	Red	FEU
	G4SRF-SP	Red	FUEGO
	G4SRN	Red	None
	G4SWF	White	FIRE
	G4SWF-FR	White	FEU
	G4SWF-SP	White	FUEGO
	G4SWN	White	None
	G4SWA	White	Alert

 <b>Speaker-strobes</b>	G4SVRF	Red	FIRE
	G4SVRF-FR	Red	FEU
	G4SVRF-SP	Red	FUEGO
	G4SVRN	Red	None
	<b>G4SVWF</b>	<b>White</b>	<b>FIRE</b>
	G4SVWF-FR	White	FEU
	G4SVWF-SP	White	FUEGO
	G4SVWN	White	None
	G4SVWA	White	Alert

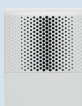
Replacement Appliance Covers	Color	Marking	
 <b>Speakers</b>	G4SRA-CVR	Red	ALERT
	G4SRF-CVR	Red	FIRE
	G4SRF-FR-CVR	Red	FEU
	G4SRF-SP-CVR	Red	FUEGO
	G4SRN-CVR	Red	None
	G4SWA-CVR	White	ALERT
	G4SWF-CVR	White	FIRE
	G4SWF-FR-CVR	White	FEU
	G4SWF-SP-CVR	White	FUEGO
	G4SWN-CVR	White	None

 <b>Speaker-strobe Covers</b>	G4SVRA-CVR	Red	ALERT
	G4SVRF-CVR	Red	FIRE
	G4SVRF-FR-CVR	Red	FEU
	G4SVRF-SP-CVR	Red	FUEGO
	G4SVRN-CVR	Red	None
	G4SWA-CVR	White	ALERT
	G4SWF-CVR	White	FIRE
	G4SWF-FR-CVR	White	FEU
	G4SWF-SP-CVR	White	FUEGO
	G4SVWN-CVR	White	None

## Accessories



GRSW-10

Room Side Wiring Plate (required, ordered separately)



G4TR

Trim plate, G4 Series, red



G4TW

Trim plate, G4 Series, white

27193-21

Two-gang surface mount box, red

27193-26

Two-gang surface mount box, white

## Model Number Syntax, Appliances

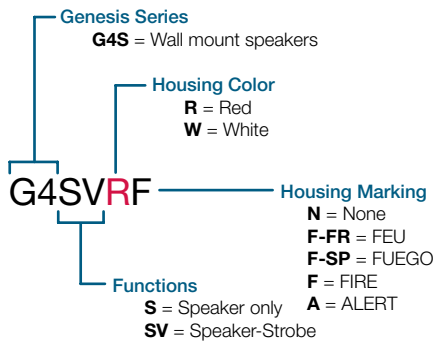

## Model Number Syntax, Replacement Covers

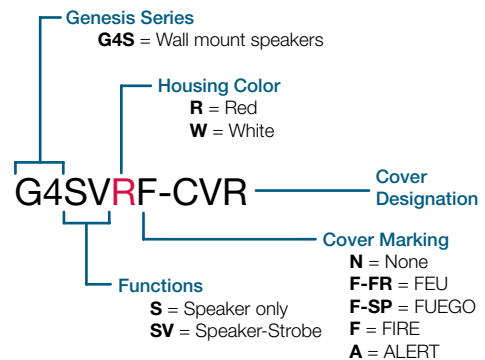



LIFE SAFETY & INCIDENT MANAGEMENT

**Contact us**

Phone: 800-655-4497 (Option 4)

Email: [edwards.fire@carrier.com](mailto:edwards.fire@carrier.com)

Website: [edwardsfiresafety.com](http://edwardsfiresafety.com)

8985 Town Center Pkwy  
Bradenton, FL 34202

© 2020 Carrier  
All rights reserved.

---

LIFE SAFETY &amp; INCIDENT MANAGEMENT

# Ceiling Mount Speakers and Speaker-Strobes

## Genesis LED GCS Series

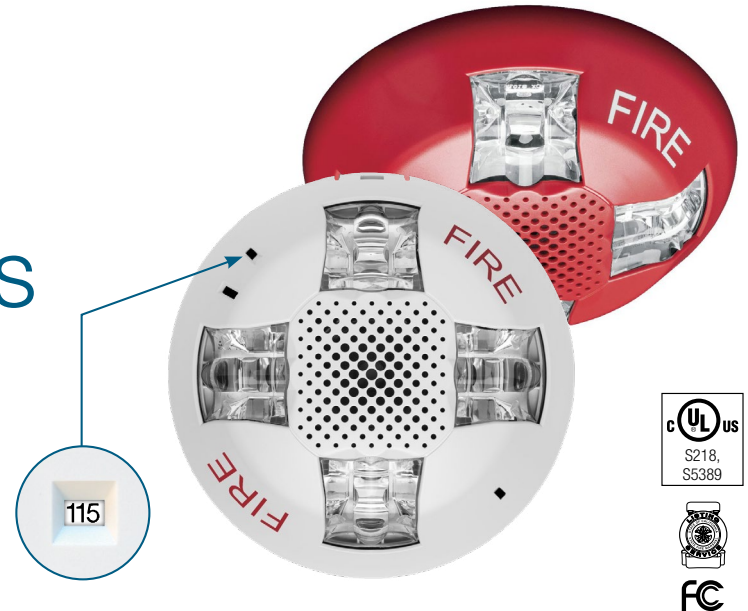

### Overview

Genesis LED GCS Series speakers and speaker-strobes combine high performance output with a sleek low profile design and energy-efficient technology that makes them less expensive to install and operate. High performance LEDs require fewer power supplies, backup power, and batteries. These new appliances are designed with energy-efficiency, and life safety in mind.

Speakers feature selectable wattage taps, while speaker-strobes allow for both wattage and light output levels to be configured in the field. Both settings remain clearly visible — even after final installation. Speakers are also capable of both 25V and 70V and voltage in a single model with a field selectable switch. All this flexibility allows devices to be easily fine-tuned to exactly how they're needed to perform. All Genesis speakers include a DC blocking capacitor to allow electrical supervision of the audio distribution circuit.

Genesis LED GCS Series uses high efficiency optics, combined with patented electronics, to deliver a highly controlled and efficiently focused light distribution pattern in exchange for lower current requirements. Strobes feature field-selectable 15, 30, 75, or 115 cd light output.

Compared with Xenon-type strobes, Genesis LED GCS Series appliances offer greatly reduced current draw which provides benefits in longer circuit lengths, more devices per circuit, smaller wire gauge and reduced power supply quantities for an installation. They are also backwards compatible with legacy strobes, so there's no need to replace all your existing devices to upgrade to

new LED technology. In fact, GCS strobes can be mixed on the same circuit and used in the same field of view as Xenon-based strobes. This makes Genesis LED GCS Series ideal for new installations and retrofits alike.

Field-configurable sound output levels provide the flexibility modern life safety projects demand, while the Genesis LED control protocol keeps multiple strobes on compatible NAC circuits synchronized to well within NFPA 72 requirements. They also meet NFPA and UL 520Hz requirements for sleeping areas making them ideal for new construction or retrofits.

GCS Series speakers produce crisp, clear voice audio output that is highly intelligible over large areas. In an emergency, intelligibility is critical to life safety. Understanding the content of the message is as important as knowing there is an emergency. Intelligibility is measured in Speech Transmission Index and anything above .76 is considered excellent. GCS Series speakers deliver audio with an STI of .81 ensuring the message is clear.

Serviceability is another area where GCS Series appliances shine. The universal room side wiring plate allows for pre-installation and electrical wiring as well as checking continuity with the included diagnostics check bar. GCS Series devices can then be easily snapped into place with the confidence of knowing the wiring is correct. The innovative under-cover diagnostic test points provide easy access to device circuit testing while mounted.



## Standard Features

- **High Fidelity performance with excellent STI**
  - Increased sound fidelity and audio intelligibility with an STI rating of .81 (More than .76 is excellent)
- **Low Frequency (520Hz) capable**
  - Low frequency output meets NFPA standards for newly constructed commercial sleeping areas
- **High Performance LED Strobe Technology**
  - Ultra low device current consumption allows:
    - More devices per circuit
    - Ability to use lower gauge wire
    - Longer wire runs
    - Fewer booster power supplies
  - High efficiency optics
  - Selectable 15, 30, 75, or 115 cd light output
  - LED devices may be mixed with legacy Xenon strobes on the same circuit and in the same field of view
- **Field flexibility**
  - Speakers are also capable of both 25V and 70V and voltage in a single model with a field selectable switch
  - Speakers feature selectable wattage taps for ¼W, ½W, 1W, and 2W to configure sound output levels in the field
- **Low-profile Design**
  - Ultra-slim... protrudes about 1.5" from the mounting surface
  - Attractive appearance... no visible mounting screws
- **Multiple "FIRE" Marking Options**
  - Order English, French, Spanish or no FIRE markings
  - Change markings at any time with replaceable quick-swap covers
- **Easy to Install**
  - Pre-install and pre-wire with convenient universal room side wiring plate
  - Check electrical continuity on room side wiring plate with included diagnostics check bar
  - Diagnostics port streamlines device circuit testing
  - Fits 2-gang and 4-inch square electrical boxes
  - Optional red and white trim plates available
  - Slide switches for field configuration
  - 12 to 18 AWG in-out screw terminals for quick wiring
- **Current draw is the same for all candela output settings**
  - Easier for new system design
  - Flexible for future changes in light output needs

## Application

### Strobes

Genesis GCS Series strobes are UL 1971-listed for use indoors as wall or ceiling public-mode notification appliances for the hearing impaired. Prevailing codes require strobes to be used where ambient noise conditions exceed 105 dBA (87 dBA in Canada), where occupants use hearing protection, and in areas of public accommodation as defined in the *Americans with Disabilities Act*.

Synchronization is important in order to avoid triggering seizures in people with photosensitive epilepsy. All Genesis strobes exceed UL synchronization requirements (within 10 milliseconds over a two-hour period) when used with a synchronization source. See the specifications table for a list of compatible sources.

### Speakers

The suggested sound pressure level for each signaling zone used with alert or alarm signals is a minimum of 15 dB above the average ambient sound level or 5 dB above the maximum sound level having a duration of at least 60 seconds, whichever is greater. This is measured 5 feet (1.5 m) above the floor.

Doubling the distance from the signal to the ear will theoretically cause a 6 dB reduction in the received sound pressure level. The actual effect depends on the acoustic properties of materials in the space. Doubling the power output of a device (e.g.: a speaker from 1W to 2W) will increase the sound pressure level by 3dB.

### High Fidelity Sound

Genesis LED GCS Series High Fidelity appliances feature 87dB of sound output along with a highly intelligible Speech Transmission Index (STI) rating of .81. An STI rating above .76 is considered excellent for speech intelligibility. They are also effective in areas subject to high levels of ambient noise.

These appliances are ideal for hotels, dormitories and other residential occupancies that have sleeping areas that require 520Hz tones. In sleeping areas, always ensure that the wattage tap of the speaker is set sufficiently high so that the sound pressure reaches at least 75 dBA at the pillow.

These appliances are part of an end-to-end audio system approved for use in sleeping areas when used in conjunction with approved audio hardware and a factory-supplied 520 Hz tone. Check the System Compatibility List for other 520 Hz signaling requirements.

## Installation

Genesis GCS speakers and speaker-strobes mount to the required GRSW room side wiring plate. The GRSW mounting plate is ordered separately from the GCS device in packs of 10 (GRSW-10) for convenient pre-installing and pre-wiring. The device can be removed easily from the room side wiring plate by pushing up with a screwdriver. The cover can also be removed from the device easily with a screwdriver to access the light and sound output settings and a diagnostics test port for voltage testing.

Genesis LED GCS Series speakers and speaker-strobes mount to any standard two-gang and 4-inch square electrical box. Matching optional GCT trim rings are available to cover oversized openings. Optional color matched double-gang surface boxes are also available.

# Installation

Electrical Box

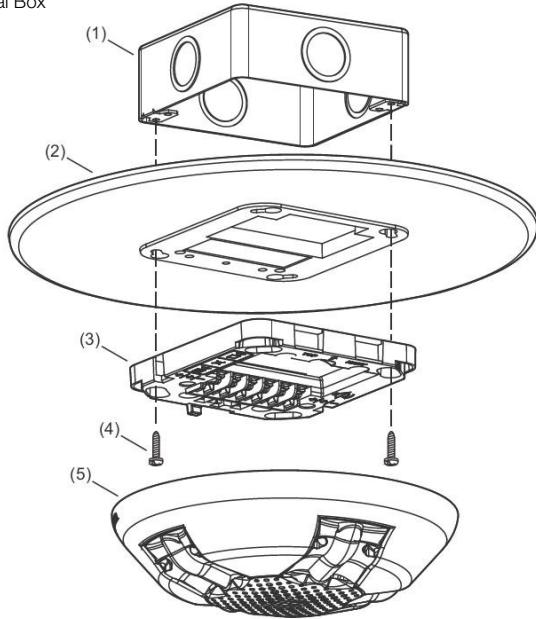

- (1) Electrical box
- (2) Trim plate (optional)
- (3) Wiring plate (required, ordered separately)
- (4) Machine screw (2X, supplied with wiring plate)
- (5) Notification appliance

Removing Cover

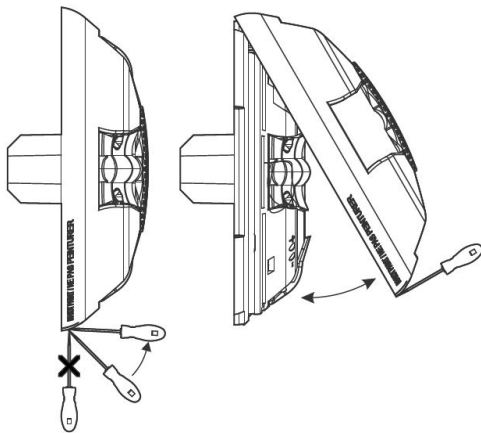

Removing Device

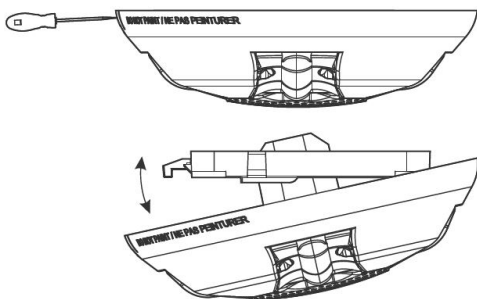

# Dimensions

GCS Notification Appliances

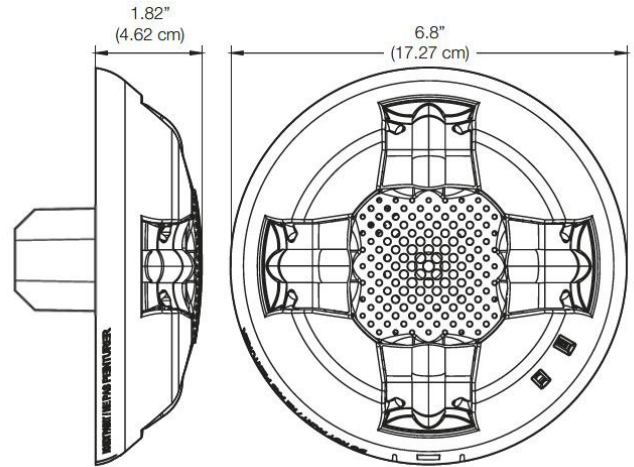

GCT Trim Plate (optional)

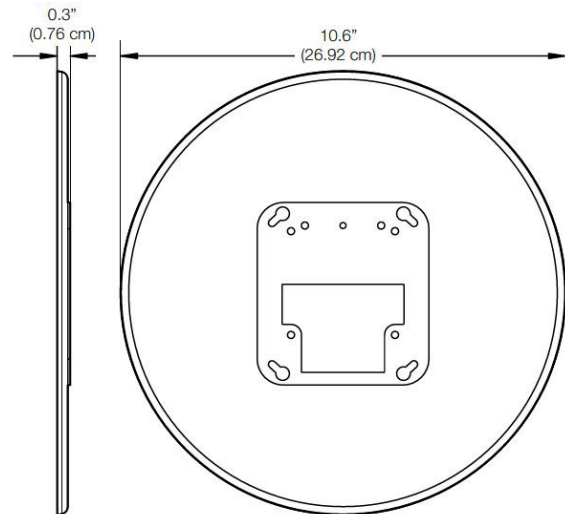

# Wiring

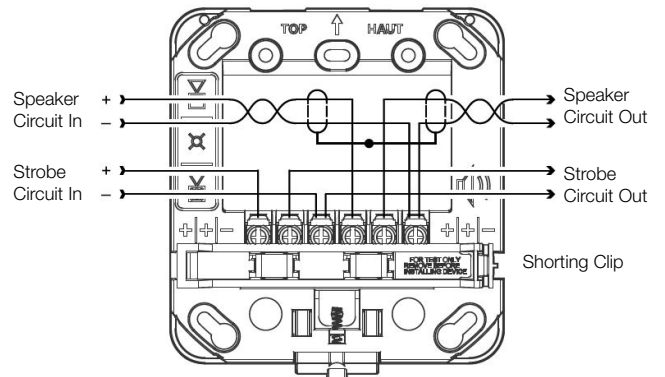

Test points indicated above are used to validate the Notification Appliance Circuit and verify device function.

# Diagnostics

## Strobe Circuit Test Points

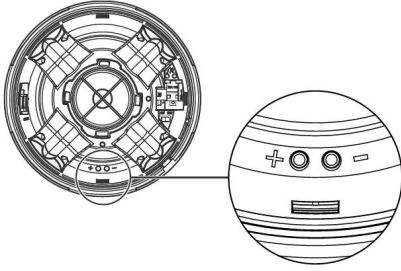

## Speaker Circuit Test Points

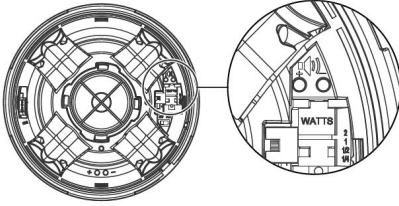

# Field Configuration

Genesis LED speakers are capable of both 25V and 70V operation depending on the system. The voltage is set via a switch under the cover. Speakers also may be set for 1/4, 1/2, 1, or 2 watt operation. The wattage setting is visible through a small window on the side of the device and is changed by simply sliding the switch under the cover until the desired setting appears in the window. The speaker does not have to be removed to change the wattage, only the cover skin.

Genesis LED clear strobes and speaker-strobes may be set for 15, 30, 75, or 115 candela output. The output setting is changed by simply removing the cover and sliding the candela switch to the desired setting. The device does not have to be removed from the wall to change the output setting. The setting remains visible through a small window on the left-hand side of the device after the cover is closed.

# Light and Sound Output Settings

## Light Output Setting (Candela)

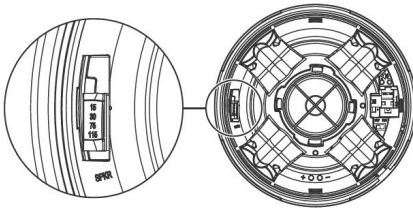

## Sound Settings (Watts and Volts)

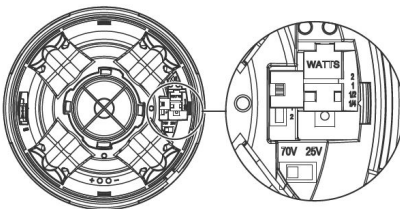

# Operating current

## Strobes

Strobe setting	16 to 33 VDC	16 to 33 VFWR
15, 30, 75, 115	35 mA	45 mA

Note: Current draw is the same for all candela settings

## Sound Level Output

Voltage setting	Wattage setting	Reverberant (UL 1480)	Anechoic (CAN/ULC-S541)
25V / 70V	1/4 W	78	77
	1/2 W	81	80
	1W	84	83
	2W	87	86

# Sound Output

## Sound pattern (ULC)

Axis	Angle	Change in output
Horizontal	120° and 60°	-3 dBA
	140° and 40°	-6 dBA
Vertical	120° and 60°	-3 dBA
	145° and 40°	-6 dBA

# Light Distribution

Horizontal Left Horizontal Right

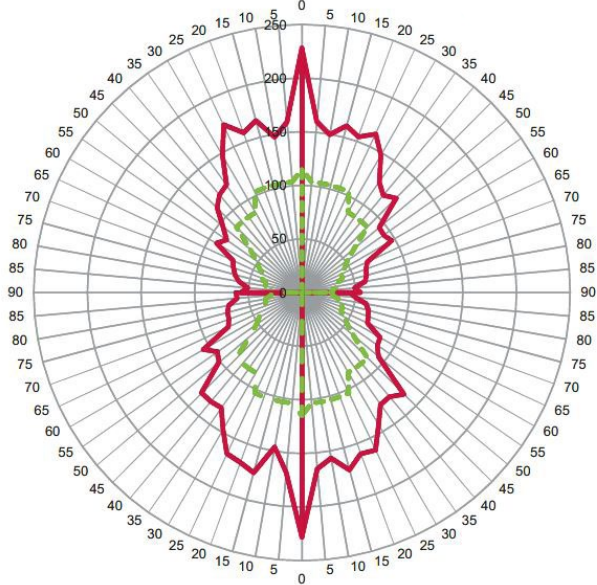



— Measured  
- - - UL Minimum

Vertical Bottom

# Ordering Information



Notification Appliances		Color	Marking
 <b>Speakers</b>	GCSRFB	Red	FIRE
	GCSRFB-FR	Red	FEU
	GCSRFB-SP	Red	FUEGO
	GCSRBN	Red	None
	<b>GCSWF</b>	<b>White</b>	<b>FIRE</b>
	GCSWF-FR	White	FEU
	GCSWF-SP	White	FUEGO
	GCSWBN	White	None
	GCSWA	White	ALERT

 <b>Speaker-strobes</b>	GCSVRF	Red	FIRE
	GCSVRF-FR	Red	FEU
	GCSVRF-SP	Red	FUEGO
	GCSVRN	Red	None
	<b>GCSWF</b>	<b>White</b>	<b>FIRE</b>
	GCSWF-FR	White	FEU
	GCSWF-SP	White	FUEGO
	GCSWBN	White	None
	GCSWA	White	ALERT

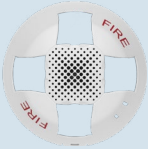
Replacement Appliance Covers		Color	Marking
 <b>Speaker Covers</b>	GCSRA-CVR	Red	ALERT
	GCSRFB-CVR	Red	FIRE
	GCSRFB-FR-CVR	Red	FEU
	GCSRFB-SP-CVR	Red	FUEGO
	GCSRBN-CVR	Red	None
	GCSWA-CVR	White	ALERT
	GCSWF-CVR	White	FIRE
	GCSWF-FR-CVR	White	FEU
	GCSWF-SP-CVR	White	FUEGO
	GCSWBN-CVR	White	None

 <b>Speaker-strobe Covers</b>	GCSVRA-CVR	Red	ALERT
	GCSVRF-CVR	Red	FIRE
	GCSVRF-FR-CVR	Red	FEU
	GCSVRF-SP-CVR	Red	FUEGO
	GCSVRN-CVR	Red	None
	GCSWA-CVR	White	ALERT
	GCSWF-CVR	White	FIRE
	GCSWF-FR-CVR	White	FEU
	GCSWF-SP-CVR	White	FUEGO
	GCSWBN-CVR	White	None

## Accessories

	<b>GRSW-10</b>	Room Side Wiring Plate 10 pack (required, ordered separately)		GCTR	Trim plate, GC Series, red		GCTW	Trim plate, GC Series, white
			27193-21	Two-gang surface mount box, red		27193-26	Two-gang surface mount box, white	

## Model Number Syntax, Appliances

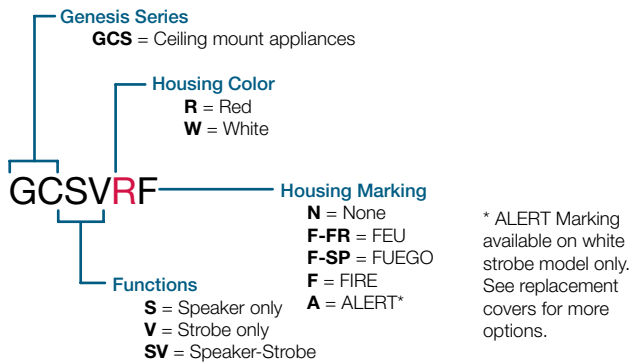

## Model Number Syntax, Replacement Covers

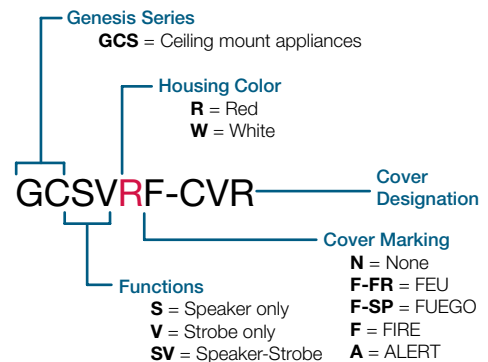



LIFE SAFETY & INCIDENT MANAGEMENT

**Contact us**

Phone: 800-655-4497 (Option 4)  
Email: [edwards.fire@carrier.com](mailto:edwards.fire@carrier.com)  
Website: [edwardsfiresafety.com](http://edwardsfiresafety.com)

8985 Town Center Pkwy  
Bradenton, FL 34202

© 2020 Carrier  
All rights reserved.

## Specifications

Strobe operating voltage	16 to 33 VDC, 16 to 33 VFWR
Speaker operating voltage	25VRMS of 70VRMS (selectable)
Speaker frequency response	400Hz-4,000Hz
Light output	15, 30, 75, or 115 candela
Strobe flash rate	1 fps (flash per second) approx.
Synchronization	20 Ω max. between any two devices. To determine allowed wire resistance, refer to these specifications, and the specifications for the synchronized signal source.
Synchronization Sources	Edwards CC Series Signal Modules, Booster and Auxiliary Power Supplies, Intelligent and Conventional Control Panels
Wire size	12 to 18 AWG (0.75 to 2.50 mm <sup>2</sup> )
Dimensions (Ø x D)	6.8 x 1.82 in (17.27 x 4.62 cm)
Strobe-to-box center offset	-1.70 inches (-4.32 cm)
Compatible electrical boxes [1]	2-gang, 4-inch square
Trim plates	GCTR, GCTW 10.6 x 0.3 in. (26.92 x 0.76 cm)
Operating environment	
Temperature	32 to 122°F (0 to 50°C)
Relative humidity	0 to 93% noncondensing
Storage Temperature	-40 to 158 F (-40 to 70 C)
RAL Color	Red=RAL 3013 White=RAL 9002

[1] Electrical boxes must be at least 1-1/2 in. (3.81 cm) deep.  
[2] Recommend electrical boxes be mounted at 81 inches AFF

# DTK-HW Series

Equipment Panel/Dedicated Circuit Surge Protective Device



DTK-120HW

## Product Features

- Available for 120V and 120/240V systems
- Approved for 20A circuit breakers
- Diagnostic LED indicates ground presence, system power and SPD function
- Weatherproof enclosure
- Small footprint enables installation in a variety of locations
- Complies with ANSI/IEEE C62.41 and C62.45 Category B standards

## Applications

- Equipment Panel
- Dedicated Branch Circuit

## Accessories

- DIN Rail Mounting Kit – Part Number DTK-DRK

DITEK's DTK-HW Series of surge protectors are designed and manufactured to meet the standards of the life safety industry. These compact, parallel-mount surge protectors are widely used to protect fire alarm panels and other dedicated branch circuit loads.

## Technical Specifications

Part Number:	DTK-120HW	DTK-120/240HW
Service Voltage:	Single (2W+G), 120VAC	Split (3W+G), 120/240VAC
MCOV:	130V	130/260V
Protection Modes:	L-G, L-N, N-G	L-L, L-G, L-N, N-G
Voltage Protection Rating:	700V L-N, L-G 600V N-G	700V L-N, L-G 600V N-G, 1200 L-L
Surge Current Rating:	18,000A	32,000A
SCCR:	10,000A	
Nominal Discharge Current Rating ( $I_n$ ):	3kA	

## Mechanical Characteristics

Connection Method:	3/4" NPT threaded fitting
Housing:	ABS
Temperature Range:	-40°F - 185°F (-40°C - 85°C)
Maximum Humidity:	95% non-condensing
Dimensions:	2.83"L x 1.68"W x 2.93" H (71.9mm x 42.7mm x 74.4mm)
Weight:	0.5lb (227g)

## Quality, Standards & Approval

Agency Approvals:	UL 1449, cUL
SPD Type:	SPD Type 2
Standards Compliance	IEEE Category B
Warranty:	Ten Year Limited

Every precaution has been taken to ensure that this literature is accurate and complete. DITEK Corporation assumes no responsibility and disclaims all liability for damages resulting from the use of this information or for any errors or omissions.