

# Dollar General

US 421 South, Lillington, North Carolina  
Store #23725



Joint Venture: John P. Watkins, Architect . 56 Hillmark Drive . Columbia, South Carolina 29210 . Phone 803-779-7570

Craig A. Otto, Architect, Inc. . 5044 Augusta Road . Lexington, South Carolina 29072 . Phone 803-957-9004 . craig@craigottoarchitect.com

<p><b>ARCHITECT</b> MR. CRAIG OTTO CRAIG A. OTTO, ARCHITECT, INC. 5044 AUGUSTA ROAD LEXINGTON, SC. 29072 803-957-9004</p>	<p><b>CIVIL ENGINEER</b> MR. MATTHEW E. LOWDER BOWMAN NORTH CAROLINA, LTD. 4004 BARRETT DRIVE, SUITE 101 RALEIGH, NC 27609 919-553-6570</p>	<p><b>STRUCTURAL ENGINEER</b> MR. LUCAS YOUNG FULLER GROUP, INC. 1350 CLEVELAND STREET, SUITE C GREENVILLE, SC 29607 864-235-3580</p>	<p><b>PLUMBING ENGINEERING</b> MR. RANDY COTTRELL VISTA ENGINEERING 530 S. SALUDA AVENUE COLUMBIA, SC 29205 803-799-8900</p>	<p><b>MECHANICAL ENGINEERING</b> MR. RANDY COTTRELL VISTA ENGINEERING 530 S. SALUDA AVENUE COLUMBIA, SC 29205 803-799-8900</p>	<p><b>ELECTRICAL ENGINEER</b> MR. JAMES C. SLICE H2L CONSULTING ENGINEERS 116 SOUTH PLEASANTBURG DRIVE GREENVILLE, SC 29607 864-233-8844</p>
---	---	---	--	--	--

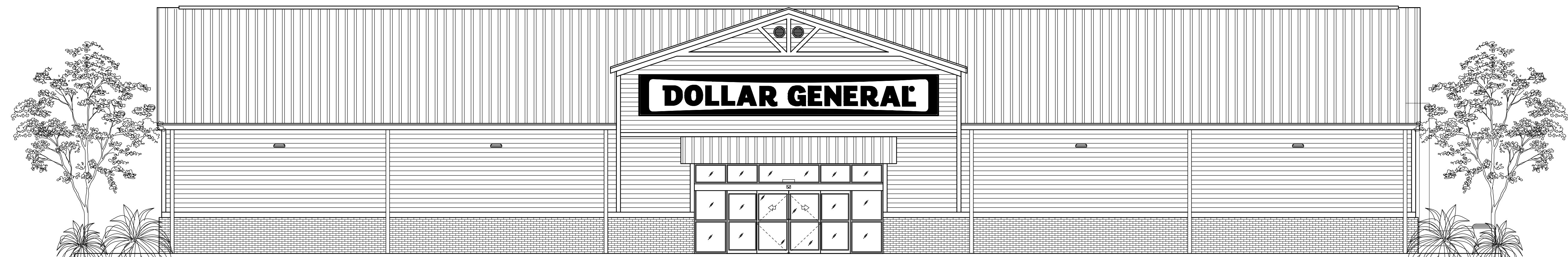

## DRAWING INDEX

<p><u>COVER SHEET</u></p> <p><u>ARCHITECTURAL</u></p> <p>LS0 BUILDING CODE REVIEW</p> <p>LS1 LIFE SAFETY PLAN &amp; DETAILS</p> <p>LS2 APPENDIX B</p> <p>F1.1 FIXTURE LAYOUT PLAN</p> <p>A1.1 FLOOR PLAN AND DETAILS</p> <p>A1.2 REFLECTED CEILING PLAN</p> <p>A2.1 EXTERIOR ELEVATIONS, NOTES, DETAILS</p> <p>A3.1 ADDITIONAL SECTIONS AND DETAILS</p> <p>A4.1 ENLARGED PLAN, INTERIOR ELEVATIONS</p> <p>A4.2 DUMPSTER ENCLOSURE PLAN &amp; DETAILS</p> <p>A5.1 WALL SECTIONS</p> <p>A5.2 WALL SECTIONS</p> <p>A6.1 DOOR AND FINISH SCHEDULES AND DETAILS</p> <p>A6.2 VENDORS, PARTS SCHEDULE, AND INTERIOR ELEVATIONS</p>	<p><u>CIVIL</u></p> <p>... SEE CIVIL COVER SHEET FOR SHEET LIST TABLE</p> <p><u>STRUCTURAL</u></p> <p>S1 FOUNDATION / SLAB PLAN</p> <p>S2 ROOF PLAN, DETAILS, AND SCHEDULES</p> <p>S3 GENERAL NOTES</p>	<p><u>PLUMBING</u></p> <p>P1.1 PLUMBING FLOOR PLAN</p> <p>P2.1 PLUMBING SCHEDULES, DETAILS</p> <p>P3.1 PLUMBING SPECIFICATIONS</p> <p><u>MECHANICAL</u></p> <p>M1.1 HVAC FLOOR PLAN</p> <p>M2.1 HVAC DETAILS, NOTES</p> <p>M3.1 HVAC SPECIFICATIONS</p> <p>M3.2 HVAC SPECIFICATIONS</p> <p>M3.3 HVAC SPECIFICATIONS</p>	<p><u>ELECTRICAL</u></p> <p>E1 POWER PLAN</p> <p>E2 LIGHTING PLAN</p> <p>E3 SITE LIGHTING PLAN</p> <p>E4 DATA CABLING DIAGRAM</p> <p>E5 PANEL SCHEDULES THREE PHASE</p> <p>E6 EMS LOW VOLTAGE PLAN</p>
---	---	---	--

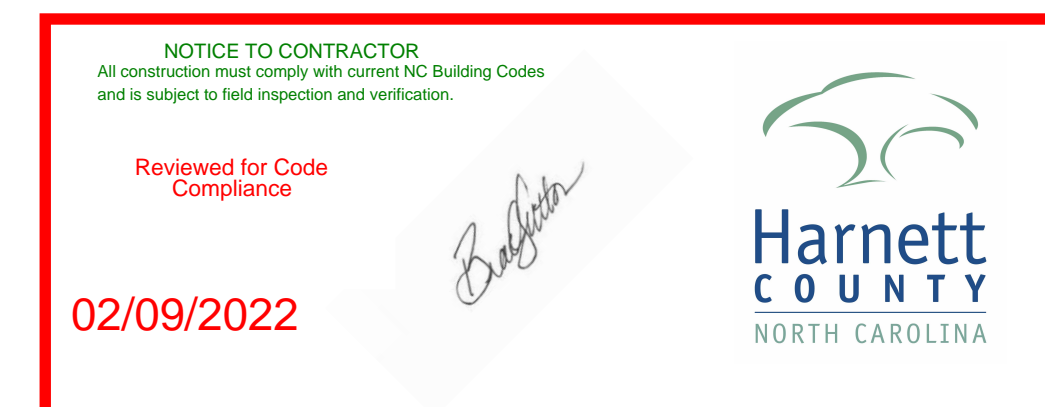

Revised January 18, 2022  
December 8, 2021

# 2018 North Carolina State Building Code

## Review and Summary

The following is a review of and synopsis of selected portions of the 2018 North Carolina State Building Code which apply to this project. Although all portions that apply have not been reprinted, the Code, in its entirety, shall be considered printed here in full.

The General Contractor, subcontractors, and suppliers shall be responsible for meeting all requirements of the 2018 North Carolina State Building Code, 2018 North Carolina State Fire Code, 2018 North Carolina State Mechanical Code, 2018 North Carolina State Plumbing Code and 2018 North Carolina State Fuel Gas Code, 2018 North Carolina State Energy Conservation Code (or ASHRAE 90.1 Standard), 2017 National Electric Code, 2009 ICC/ANSI A117.1 Accessibility Code, 2010 ADA Standards for Accessible Design, NFPA 10, and all other NFPA codes that apply to this project. Should a discrepancy between the codes and the drawings exist, the General Contractor shall immediately inform the Architect and request a solution. Should the General Contractor, subcontractor, or supplier proceed with the work without notifying the Architect, the General Contractor shall assume responsibility for the work and shall be required to correct the work.

Summary:

Scope of Work: New  
Occupancy Group: M and S-1 (No separation required)  
Construction Type: V-B  
Fire Protection Systems: None Required  
Height: 28 feet 0 inches (40 feet allowed)  
Stories: 1 (1 story allowed)  
Area: 10,751 square feet  
Separation Distance: Greater than 10 feet all exterior walls  
Rated Assemblies: None Required  
Total Occupant Load: 156

Chapter 3

1. 309.1 Mercantile Group M. Mercantile Group M occupancy includes, among others, buildings or structures or a portion thereof, for the display and sale of merchandise, and involves stocks of goods, wares or merchandise incidental to such purposes and accessible to the public. Mercantile occupancies shall include, but not be limited to, the following: Retail or wholesale stores.

2. 311.2 Moderate-hazard storage, Group S-1. Buildings occupied for storage uses that are not classified as Group S-2, including but not limited to, storage of the following: (see listing in code)

Chapter 5

1. 504.1 General. The height, in feet, and the number of stories of a building shall be determined based on the type of construction, occupancy classification and whether there is an automatic sprinkler system installed throughout the building.

2. 504.3 Height in feet. The maximum height, in feet, of a building shall not exceed the limits specified in Table 504.3.

3. Table 504.3: Group M, Type V-B Construction, not equipped with an automatic sprinkler system: 40 feet maximum. Group S-1, Type V-B Construction, not equipped with an automatic sprinkler system: 40 feet.

4. 504.4 Number of Stories. The maximum number of stories of a building shall not exceed the limits specified in Table 504.4.

5. Table 504.4: Group M, Type V-B Construction, not equipped with an automatic sprinkler system: 1 story maximum. Group S-1, Type V-B Construction, not equipped with an automatic sprinkler system: 1 story maximum.

6. 506.1 General. The floor area of a building shall be determined based on the type of construction, occupancy classification, whether there is an automatic sprinkler system installed throughout the building and the amount of building frontage on public way or open space.

7. 506.2 Allowable area determination. The allowable area of a building shall be determined in accordance with the applicable provisions of Sections 506.2.1 through 506.2.4 and Section 506.3.

8. 506.2.1 Single occupancy, one story buildings. The allowable area of a single occupancy building with no more than one story above grade plane shall be determined in accordance with Equation 5-1:  $A_u = A_t + (NS \times I_f)$ .

Group M, Type V-B, Allowable area =  $9,000 + (9,000 \times 75\%) = 9,000 + 6,750 = 15,750$  square feet allowed.  
Group S-1, Type V-B, Allowable area =  $9,000 + (9,000 \times 75\%) = 9,000 + 6,750 = 15,750$  square feet allowed.

9. 506.3 Frontage increase. Every building shall adjoin or have access to a public way to receive an area factor increase based on frontage. Area factor increase shall be determined in accordance with Sections 506.3.1 through 506.3.3.

10. 506.3.3 Amount of increase. The area factor increase based on frontage shall be determined in accordance with Equation 5-5:  $I_f = (F/P - 0.25) W/30$   
Area factor increase =  $(431 / 431 - 0.25) 30/30$   
Area factor increase = 75%

11. The building height is 28 feet, the number of stories is 1, and the total building area is 10,751 square feet. Therefore, the height, stories, and area all comply for both occupancy groups with the frontage increase.

12. 508.1 General. Each portion of a building shall be individually classified in accordance with Section 302.1. Where a building contains more than one occupancy group, the building or portion thereof shall comply with the applicable provisions of Section 508.2, 508.3, or 508.4 or a combination of these sections.

13. 508.4 Separated occupancies. Buildings or portions of buildings that comply with the provisions of this section shall qualify as separated occupancies.

14. 508.4.1 Occupancy classification. Separated occupancies shall be individually classified in accordance with Section 302.1. Each separated space shall comply with this code based on the occupancy classification of that portion of the building.

15. 508.4.4 Separation. Individual occupancies shall be separated from adjacent occupancies in accordance with Table 508.4.

16. Table 508.4 Required separation of occupancies: Between Group M and Group S-1: No separation requirement.

Chapter 6

1. 602.5 Type V. Type V construction is that type of construction in which the structural elements, exterior walls and interior walls are of any material permitted by this code.

2. Table 601. Using Type V-B construction, all structural elements require a 0 hour fire rating (no fire rating).

3. Table 602. For Group M and S-1, Type V-B construction, the following fire ratings must be provided:  
Less than 5 feet - 2 hours      5 feet to 10 feet - 1 hour  
10 feet to 30 feet - 0 hours      Over 30 feet - 0 hours

4. Per Table 602, any exterior walls of the building less than 10 feet from a property line or an assumed imaginary property line shall be either one or two hour fire rated. Note: All exterior walls are 10 feet or more from the adjacent property line.

Chapter 8

1. Table 803.11 Interior wall and ceiling finish requirements by occupancy. Group M, Nonsprinklered. Interior exit stairways, interior exit ramps and exit passageways (not applicable): Class A. Corridors and enclosure for exit access stairways and exit access ramps (not applicable): Class B. Rooms and enclosed spaces, Class C.

2. Table 803.11 Interior wall and ceiling finish requirements by occupancy. Group S, Nonsprinklered. Interior exit stairways, interior exit ramps and exit passageways (not applicable): Class B. Corridors and enclosure for exit access stairways and exit access ramps (not applicable): Class B. Rooms and enclosed spaces, Class C.

Chapter 9

1. 903.2.1 Group M. An automatic sprinkler system shall be installed throughout buildings containing a Group M occupancy where one of the following conditions exist:

- Where a Group M fire area exceeds 12,000 square feet (not applicable)
- Where a Group M fire area is located more than three stories above grade (not applicable)
- Where the combined area of all Group M fire areas on all floors exceeds 24,000 square feet (not applicable)
- A Group M occupancy used for the display and sale of upholstered furniture or mattresses exceeds 5,000 square feet (not applicable)

2. 903.2.9 Group S-1. An automatic sprinkler system shall be installed throughout all buildings containing a Group S-1 occupancy where one of the following conditions exist:

- A Group S-1 fire area exceeds 12,000 square feet (not applicable)
- A Group S-1 fire area is located more than three stories above grade (not applicable)
- The combined area of all Group S-1 fire areas on all floors, including any mezzanines, exceeds 24,000 square feet (not applicable)

4. A Group S-1 fire area used for the storage of commercial motor vehicles where the fire area exceeds 5,000 square feet (not applicable).

5. A Group S-1 occupancy used for the storage of upholstered furniture or mattresses exceeds 2,500 square feet (not applicable).

3. Therefore, an automatic sprinkler system shall not be required for either occupancy group.

4. 906.1 General. Portable fire extinguishers shall be provided in the following locations: 1. In Group A, B, E, F, H, I, M, R-1, R-2, R-4 and S occupancies. 5. Where required by the International Fire Code sections indicated in Table 906.1.

5. 906.2 General requirements. Portable fire extinguishers shall be selected and installed in accordance with this section and NFPA 10.

6. 907.2.7 Group M. A manual fire alarm system that activates the occupant notification system in accordance with Section 907.5 shall be installed in Group M occupancies where one of the following conditions exist:

- The combined Group M occupant load of all floors is 500 or more persons (not applicable).
- The Group M occupant load is more than 100 persons above or below the lowest level of exit discharge (not applicable).

7. Therefore, a manual fire alarm system shall not be required.

Chapter 10

1. Table 1004.1.2 Maximum floor area allowances per occupant.  
Business areas: 150 gross  
Mercantile: 60 gross  
Mercantile storage, stock, shipping areas: 300 gross

2. Occupant load per Table 1004.1.2:  
Offices, Break room: 233 square feet / 150 = 2 occupants  
Mercantile: 8934 square feet / 60 = 149 occupants  
Storage, stock, shipping areas: 1365 square feet / 300 = 5 occupants

3. The total occupant load per Table 1004.1.2 is 156 occupants.

4. Table 1005.3.2 Other egress components. The capacity, in inches, of means of egress components other than stairways shall be calculated by multiplying the occupant load served by such component by a means of egress capacity factor of 0.2 inch per occupant. Therefore, 156 occupants x 0.2 inches per person equals a total egress width required is 30.8 inches. The total egress width provided throughout the entire building is 192 inches with 120 inches in the Sales area.

5. 1006.1 General. The number of exits or exit access doorways required within the means of egress system shall comply with the provisions of Section 1006.2 for spaces, including mezzanines, and Section 1006.3 for stories.

6. 1006.2.1 Egress based on occupant load and common path of egress travel. Two exits or exit access doorways from any space shall be provided where the design occupant load or the common path of egress travel distance exceeds the values listed in Table 1006.2.1.

7. Table 1006.2.1 Spaces with one exit or exit access doorway: Group M, 43 occupants maximum, without a sprinkler system, the common path of egress travel shall be 100 feet for less than 30 occupants or 75 feet for greater than 30 occupants. Group S, 29 occupants maximum, without a sprinkler system, the common path of egress travel shall be 100 feet for less than 30 occupants or 75 feet for greater than 30 occupants.

8. 1006.3.1 Egress based on occupant load. Each story and occupied roof shall have the minimum number of exits, or access to exits, as specified in Table 1006.3.1.

9. Table 1006.3.1 Minimum number of exits or access to exits per story: 1 ? 500 occupants: 2 exits.

10. 1008.2 Illumination required. The means of egress serving a room or space shall be illuminated at all times that the room or space is occupied.

11. 1010.1.5 Floor elevation. There shall be a floor or landing on each side of a door. Such floor or landing shall be at the same elevation on each side of the door. Landings shall be level except at exterior landings, which are permitted to have a slope not to exceed 0.25 units vertical in 12 units horizontal (2 percent slope).

12. 1010.1.6 Landings at doors. Landings shall have a width not less than the width of the stairway or the door, whichever is greater. Landings shall have a length measured in the direction of travel of not less than 44 inches.

13. 1010.1.7 Thresholds. Thresholds at doorways shall not exceed 0.5 inches for doors.

14. 1010.1.9 Door operations. Except as specifically permitted by this section egress doors shall be readily openable from the egress side without the use of a key or special knowledge or effort.

15. 1010.1.9.1 Hardware. Door handles, pulls, latches, locks and other operating devices on doors required to be accessible by Chapter 11 shall not require tight grasping, tight pinching or twisting of the wrist to operate.

16. 1010.1.9.5 Unlatching. The unlatching of any door leaf shall not require more than one operation.

17. Table 1017.2 Exit access travel distance. Group M and S-1 without a sprinkler system: 200 feet.

18. 1028.5 Access to a public way. The exit discharge shall provide a direct and unobstructed access to a public way.

Chapter 11

1. 1103.1 Where required. Sites, buildings, structures, facilities, elements and spaces, temporary or permanent, shall be accessible to individuals with disabilities.

2. 1109.2 Toilet and bathing facilities. Each toilet room and bathing room shall be accessible. Where a floor level is not required to be connected to an accessible route, the only toilet rooms or bathing rooms provided within the facility shall not be located on an inaccessible floor. At least one of each type of fixture, element, control, or dispenser in each accessible toilet room or bathing room shall be accessible.

Chapter 12

1. 1210.1 Required fixtures. The number and type of plumbing fixtures provided in any occupancy shall comply with Chapter 29.

2. 1210.2.1 Floors and wall bases. In other than dwelling units, toilet, bathing, and shower room floor finish materials shall have a smooth, hard, nonabsorbent surface. The intersections of such floors with walls shall have a smooth, hard, nonabsorbent, vertical base that extends upward onto the walls not less than 4 inches.

3. 1210.2.2 Walls and partitions. Walls and partitions within 2 feet of service sinks, urinals and water closets shall have a smooth, hard, nonabsorbent surface, to a height of 4 feet above the floor, and except for structural elements, the materials used in such walls shall be a type that is not adversely affected by moisture.

Chapter 18

1. 1804.4 Site grading. The ground immediately adjacent to the foundation shall be sloped away from the building at a slope of not less than one unit vertical in 20 units horizontal (5-percent slope) for a minimum distance of 10 feet (3048 mm) measured perpendicular to the face of the wall or an approved alternate method of diverting water away from the foundation shall be used. The procedure used to establish the final ground level adjacent to the foundation shall account for additional settlement of the backfill.

JOHN P. WATKINS, ARCHITECT  
56 HILLMARK DRIVE  
COLUMBIA, SOUTH CAROLINA 29210

Craig A. Otto  
ARCHITECT, INC.

DESIGN • PLANNING • ARCHITECTURE

5044 Augusta Road  
Lexington, South Carolina 29072  
Phone (803) 957-9004  
Fax (803) 957-2050

No.	Revisions	Date

All rights reserved. This drawing and the design shown thereon are copyrighted as prescribed by the laws of the United States and are the sole property of Craig A. Otto, Architect, Inc. Anyone duplicating, reproducing, or causing to be reproduced these drawings or the design thereon without permission of the architect will be subject to legal action.

Project Title **DOLLAR GENERAL #23725**  
US 421 S, LILLINGTON, NC

Drawing Title **BUILDING CODE REVIEW**

Consultant

Seal	Date DECEMBER 8, 2021
	Drawn By OTTO
	Drawing No. <b>LSO</b>

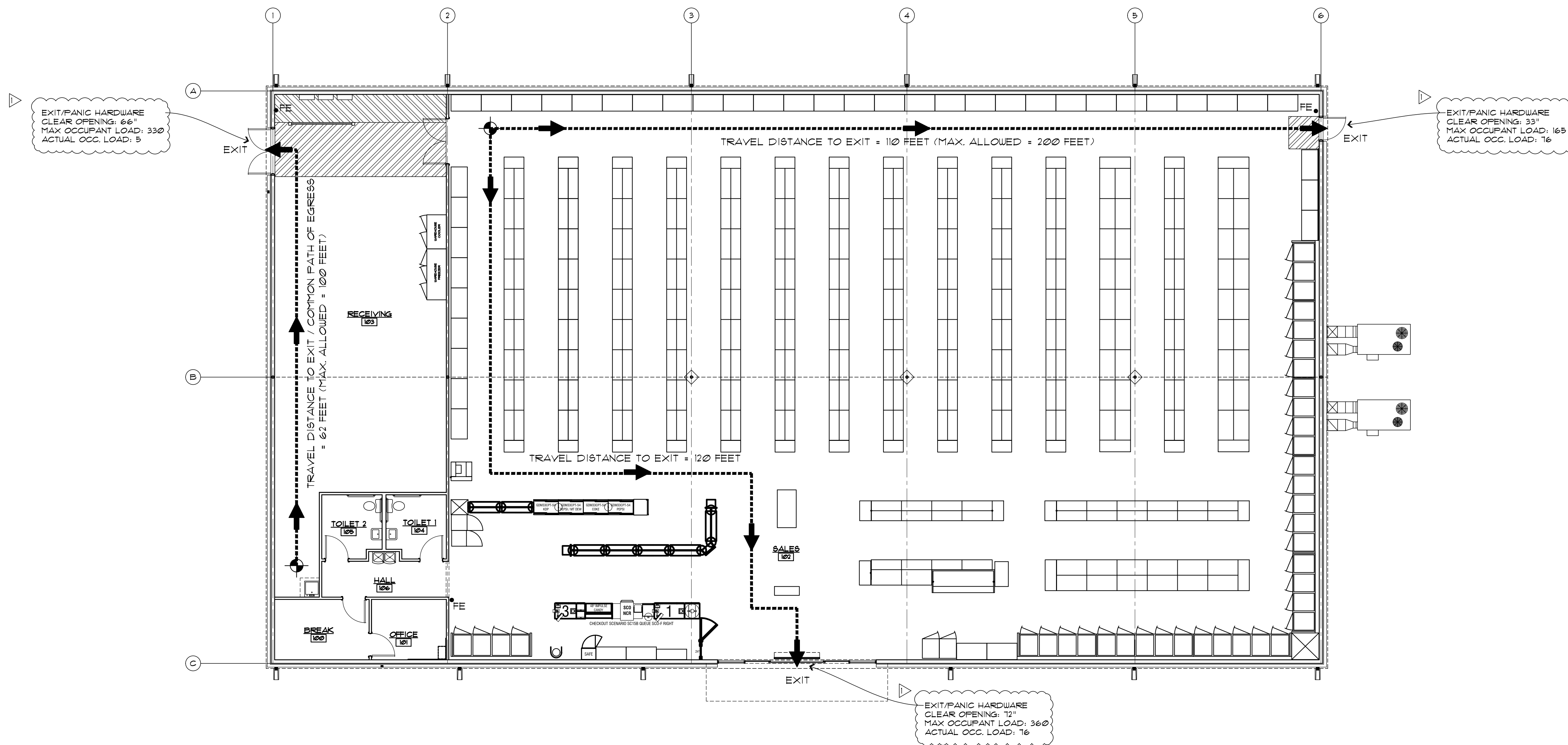

**1 LIFE SAFETY PLAN (DGP21-C)**  
 SCALE: 1/8" = 1' - 0"  
 10,751 SQUARE FEET  
 VERIFY WITH FINAL FIXTURE PLAN

**SQUARE FOOTAGE LEGEND:**

OVERALL BUILDING DIMENSIONS: 140'-11" x 76'-9"  
 TOTAL GROSS SQUARE FOOTAGE: 10,751 SQUARE FEET  
 SALES FLOOR NET AREA: 8,934 SQUARE FEET  
 STOCK ROOM NET AREA: 1,365 SQUARE FEET  
 OFFICE / BREAK RM. NET AREA: 233 SQUARE FEET  
 RESTROOM / HALL NET AREA: 219 SQUARE FEET

EGRESS CAPACITY TABULATION				
OCCUPANCY	AREA SQ. FT.	OCCUPANT PER SQ. FT.	OCCUPANT LOAD	COMMENTS
MERCANTILE	8,934 SQ. FT.	60 GROSS	149 PEOPLE	
STOCK ROOM (STORAGE)	1,365 SQ. FT.	300 GROSS	5 PEOPLE	
BUSINESS	233 SQ. FT.	150 GROSS	2 PEOPLE	
TOTAL GROSS	10,751 SQ. FT.		156 PEOPLE	

**BUILDING CODE REVIEW DATA:**  
 APPLICABLE CODES  
 2018 NORTH CAROLINA STATE BUILDING CODE  
 2018 NORTH CAROLINA STATE PLUMBING CODE  
 2018 NORTH CAROLINA STATE MECHANICAL CODE  
 2018 NORTH CAROLINA STATE ENERGY CONSERVATION CODE (ASHRAE 90) STANDARD PER SECTION C4012 ITEM 1)  
 2011 NATIONAL ELECTRIC CODE  
 2009 ICC/ANSI A117.1 ACCESSIBILITY CODE  
 2010 ADA STANDARDS FOR ACCESSIBLE DESIGN

OCCUPANCY: GROUP M - MERCANTILE  
 CONSTRUCTION: TYPE V-B UNSPRINKLERED, UNPROTECTED  
 MAXIMUM HEIGHT: 40'-0" (1 STORY)  
 (TABLE 503)  
 ACTUAL BUILDING HEIGHT: 28'-0" (1 STORY)  
 MAXIMUM AREA: 15,750 SQ. FT. PER STORY  
 ACTUAL AREA: 10,751 SQUARE FEET

• FE FIRE EXTINGUISHERS SHALL BE PROVIDED AND LOCATED AS REQUIRED BY THE INTERNATIONAL BUILDING CODE AND NFPA 10

NOTE: FIRE EXTINGUISHERS SHALL NOT BE OBSTRUCTED OR OBSCURED FROM VIEW AND MUST BE INSTALLED IN CONSPICUOUS LOCATIONS.

**FLAME SPREAD NOTES:**

- ALL WALL AND CEILING FINISH MATERIALS INCLUDING VINYL AND RUBBER BASE, SHALL BE CLASSIFIED IN ACCORDANCE WITH ASTM E-84 AND SHALL COMPLY WITH CLASS "B" INTERIOR FINISH WITH FLAME SPREAD 20-75 AND SMOKE DEVELOPMENT OF 0-450.
- ALL EXTERIOR DOORS AND FRAMES SHALL COMPLY WITH CLASS A INTERIOR FINISH WITH FLAME SPREAD 0-25 AND SMOKE DEVELOPED 0-450.
- FLOORING MATERIAL SHALL HAVE A MINIMUM OF CLASS II INTERIOR FLOOR FINISH RATING AS CLASSIFIED IN ACCORDANCE WITH NFPA 253.

**LEGEND:**

FE  
 • INDICATES FIRE EXTINGUISHER LOCATION

**NOTES:**

- PROVIDE FIRE EXTINGUISHER HAVING A MINIMUM RATING OF 3A-40BC FOR EVERY 3,000 SQUARE FEET. ALL EXTINGUISHERS SHALL BE CONSPICUOUSLY LOCATED AND BE READILY ACCESSIBLE.
- THE TOP OF THE EXTINGUISHER SHALL NOT EXCEED 48" ABOVE FINISH FLOOR WHILE THE BOTTOM OF THE EXTINGUISHER SHALL BE MOUNTED AT 4" MIN. ABOVE FINISH FLOOR.
- TRAVEL DISTANCE TO ANY EXTINGUISHER SHALL NOT EXCEED 75'-0".
- ALL REQUIRED EXITS, WAY OF APPROACH THERETO, AND WAY OF TRAVEL FROM THE EXIT INTO THE STREET SHALL BE CONTINUOUSLY MAINTAINED FREE FROM ALL OBSTRUCTIONS AND IMPEDIMENTS FOR UNOBSTRUCTED EGRESS IN THE CASE OF FIRE OR OTHER EMERGENCY.

**JOHN P. WATKINS, ARCHITECT**  
 56 HILLMARK DRIVE  
 COLUMBIA, SOUTH CAROLINA 29210

**Craig A. Otto**  
 ARCHITECT, INC.  
 DESIGN • PLANNING • ARCHITECTURE

5044 Augusta Road  
 Lexington, South Carolina 29072  
 Phone (803) 957-9004  
 Fax (803) 957-2050

No.	Revisions	Date
1	ADDED FURTHER INFORMATION AT ENTRANCES	1/8/22

All rights reserved. This drawing and the design shown thereon are copyrighted as prescribed by the laws of the United States and are the sole property of Craig A. Otto, Architect, Inc. Anyone duplicating, reproducing, or causing to be reproduced these drawings or the design thereon without permission of the architect will be subject to legal action.

Project Title: **DOLLAR GENERAL #23725**  
 US 421 S, LILLINGTON, NC

Drawing Title: **LIFE SAFETY PLAN**

Consultant:

Seal:

Date: **DECEMBER 8, 2021**  
 Drawn By: **OTTO**  
 Drawing No.: **LS1**

### 2018 APPENDIX B BUILDING CODE SUMMARY FOR ALL COMMERCIAL PROJECTS (EXCEPT 1 AND 2-FAMILY DWELLINGS AND TOWNHOUSES)

(Reproduce the following data on the building plans sheet 1 of 2)

Name of Project: Dollar General #23725  
 Address: US 421 S, Lillington, North Carolina Zip Code: \_\_\_\_\_  
 Owner/Authorized Agent: Phase # ( ) E-Mail: \_\_\_\_\_  
 Owned By:  City/County  Private  State  
 Code Enforcement Jurisdiction:  City  County  State

**CONTACT: Craig A. Otto**  
 Designer: Craig A. Otto License # 4883 1957-0004 Telephone # \_\_\_\_\_ E-Mail: cotto@ottoarchitect.com  
 Architectural: Craig A. Otto License # \_\_\_\_\_ Telephone # \_\_\_\_\_ E-Mail: \_\_\_\_\_  
 Civil: Matthew F. Lender License # 4883 1553-6579 Telephone # \_\_\_\_\_ E-Mail: mlender@ottoarch.com  
 Electrical: Jill Combs License # \_\_\_\_\_ Telephone # \_\_\_\_\_ E-Mail: \_\_\_\_\_  
 Fire Alarm: \_\_\_\_\_  
 Plumbing: Handy Control License # \_\_\_\_\_ Telephone # \_\_\_\_\_ E-Mail: \_\_\_\_\_  
 Mechanical: Handy Control License # \_\_\_\_\_ Telephone # \_\_\_\_\_ E-Mail: \_\_\_\_\_  
 Sprinkler-Standpipes: \_\_\_\_\_  
 Structural: Handy Control License # \_\_\_\_\_ Telephone # \_\_\_\_\_ E-Mail: \_\_\_\_\_  
 Retaining Walls >5' High: \_\_\_\_\_  
 Other: \_\_\_\_\_  
 (FOOTNOTES should include firms and individuals such as trans, permit, prep-work, interior designers, etc.)

**2018 NC CODE FOR:**  New Construction  Addition  Renovation  
 1st Time Interior Completion  Shell/Coat  
 Phased Construction - Shell/Coat

**2018 NC EXISTING BUILDING CODE:**  Prescriptive  Repair  Chapter 14  
 Alternates:  Level I  Level II  Level III  
 Historic Property  Change of Use

CONSTRUCTED (date): \_\_\_\_\_ ORIGINAL OCCUPANCY (Ch. 3): \_\_\_\_\_  
 RENOVATED (date): \_\_\_\_\_ CURRENT OCCUPANCY (Ch. 3): \_\_\_\_\_

**RISK CATEGORY (Table 1604.5)** Current:  I  II  III  IV  
 Proposed:  I  II  III  IV

**BASIC BUILDING DATA**  
 Construction Type:  I-A  I-B  I-C  I-D  I-E  I-F  I-G  I-H  I-I  I-J  I-K  I-L  I-M  I-N  I-O  I-P  I-Q  I-R  I-S  I-T  I-U  I-V  I-W  I-X  I-Y  I-Z  
 Check all that apply:  I-B  I-C  I-D  I-E  I-F  I-G  I-H  I-I  I-J  I-K  I-L  I-M  I-N  I-O  I-P  I-Q  I-R  I-S  I-T  I-U  I-V  I-W  I-X  I-Y  I-Z  
 Sprinklers:  No  Partial  Yes  NFPA 13  NFPA 13R  NFPA 13D  
 Standpipes:  No  Yes  Class I  II  III  Wet  Dry  
 Fire District:  No  Yes (Primary)  Flood Hazard Area:  No  Yes  
 Special Inspections Required:  No  Yes

2018 NC Administrative Code and Policies Appendix B for Building

**Cross Building Area**

FLOOR	EXISTING (SQ FT)	NEW (SQFT)	RENO/ALTER (SQFT)	SUB-TOTAL
4 <sup>th</sup> Floor				
5 <sup>th</sup> Floor				
4 <sup>th</sup> Floor				
2 <sup>nd</sup> Floor				
Mezzanine				
1 <sup>st</sup> Floor		10,751		
Basement				
TOTAL		10,751		

**ALLOWABLE AREA**

**Primary Occupancy Classification: SELECT ONE**  
 Assembly:  A-1  A-2  A-3  A-4  A-5  
 Business: \_\_\_\_\_  
 Educational: \_\_\_\_\_  
 Factory: \_\_\_\_\_  
 Hazardous:  F-1 Moderate  F-2 Low  H-1 Detonate  H-2 Deflagrate  H-3 Combust  H-4 Health  H-5 HPM  
 Institutional: \_\_\_\_\_  
 I-1 Condition:  1  2  
 I-2 Condition:  1  2  
 I-3 Condition:  1  2  3  4  5  
 I-4 \_\_\_\_\_  
 Mercantile: \_\_\_\_\_  
 Residential:  R-1  R-2  R-3  R-4  S-1 Low  S-2 Low  High-piled  
 Storage:  S-1 Moderate  Parking Garage  Open  Enclosed  Repair Garage  
 Utility and Miscellaneous: \_\_\_\_\_  
 Accessory Occupancy Classification: N/A  
 Incidental Uses (Table 509): N/A  
 Special Uses (Chapter 4 - List Code Section): N/A  
 Special Provisions (Chapter 5 - List Code Section): N/A  
 Mixed Occupancy:  No  Yes Separation: 0 Hr. Exception: \_\_\_\_\_  
 Non-Separated Use (508.3)  
 The required type of construction for the building shall be determined by applying the height and area limitations for each of the applicable occupancies in the entire building. The most restrictive type of construction, so determined, shall apply to the entire building.  
 Separated Use (508.4)  II  III  IV

See below for area calculations for each story, the area of the occupancy shall be such that the sum of the ratios of the actual floor area of each use divided by the allowable floor area for each use shall not exceed 1.

Actual Area of Occupancy A	Actual Area of Occupancy B	Allowable Area of Occupancy A	Allowable Area of Occupancy B	Ratio
10751	1365	15750	15750	0.77
0.68	0.09			0.77

2018 NC Administrative Code and Policies Appendix B for Building

**2018 APPENDIX B  
BUILDING CODE SUMMARY FOR ALL COMMERCIAL PROJECTS  
STRUCTURAL DESIGN  
(PROVIDE ON THE STRUCTURAL SHEETS IF APPLICABLE)**

**DESIGN LOADS:**  
 Importance Factors: Snow (ls) 1.0 Seismic (ls) 1.0  
 Live Loads: Roof 20 psf Mezzanine 100 psf Floor 100 psf  
 Ground Snow Load: 15 psf  
 Wind Load: Ultimate Wind Speed 119 mph (ASCE-7) Exposure Category C

**SEISMIC DESIGN CATEGORY:**  A  B  C  D  
 Provide the following Seismic Design Parameters:  
 Risk Category (Table 1604.5)  I  II  III  IV  V  
 Spectral Response Acceleration  $S_s$  (0.1) 0.15  $S_1$  (0.5) 0.15  $S_{0.1}$  (0.1) 0.15  
 Site Classification (ASCE 7)  A  B  C  D  E  F  
 Data Source:  Field Test  Prescriptive  Historical Data  
 Bearing Wall  Dual w/ Special Moment Frame  
 Building Frame  Dual w/ Intermediate R/C or Special Steel  
 Moment Frame  Inverted Pendulum  
 Simplified  Equivalent Lateral Force  Dynamic  
 Analysis Procedure:  Architectural, Mechanical, Components anchored?  Yes  No

**LATERAL DESIGN CONTROL:** Earthquake  Wind

**SOIL BEARING CAPACITIES:**  
 Field Test (provide copy of test report) 3000 psf  
 Prescriptive Bearing capacity \_\_\_\_\_ psf  
 Pile size, type, and capacity \_\_\_\_\_

2018 NC Administrative Code and Policies Appendix B for Building

**2018 APPENDIX B  
BUILDING CODE SUMMARY FOR ALL COMMERCIAL PROJECTS  
MECHANICAL DESIGN  
(PROVIDE ON THE MECHANICAL SHEETS IF APPLICABLE)**

**MECHANICAL SYSTEMS, SERVICE SYSTEMS AND EQUIPMENT**

**Thermal Zone**  
 winter dry bulb: 16° F  
 summer dry bulb: 92° F

**Interior design conditions**  
 winter dry bulb: 70° F  
 summer dry bulb: 75° F  
 relative humidity: 55%

**Building heating load:** 199,518  
**Building cooling load:** 327,009

**Mechanical Space Conditioning System**  
 Unitary description of unit: PACK A/C W/ ELECT. HT.  
 heating efficiency: 98%  
 cooling efficiency: 11.0 EER  
 size category of unit: 15 TONS EA.  
 Boiler: \_\_\_\_\_  
 Chiller: \_\_\_\_\_  
 Size category: If oversized, state reason: N/A  
 Size category: If oversized, state reason: N/A

**List equipment efficiencies: SEE ABOVE**

Light Type	Lamp Type	# of Lamps	Ballast Type	# of Ballasts	W/P Nature	Total Int. Wattage Specified	Int. Wattage Allowed	Total Est. Wattage Specified	Est. Wattage Specifications
<b>INTERIOR</b>									
A/A1	LED	unknown	N/A	0	1	32	2475	15856	
<b>EXTERIOR</b>									
G	LED	unknown	N/A	0	38			1034	1236
HB/HP	LED	unknown	N/A	0	167			1034	1236

2018 NC Administrative Code and Policies Appendix B for Building

**2018 APPENDIX B  
BUILDING CODE SUMMARY FOR ALL COMMERCIAL PROJECTS  
ELECTRICAL DESIGN  
(PROVIDE ON THE ELECTRICAL SHEETS IF APPLICABLE)**

**ELECTRICAL SYSTEM AND EQUIPMENT**

**Method of Compliance:** Energy Code:  Prescriptive  Performance  
 ASHRAE 90.1:  Prescriptive  Performance

**Lighting Schedule (each fixture type) - SEE BELOW**  
 lamp type required in fixture  
 number of lamps in fixture  
 ballast type used in the fixture  
 number of ballasts in fixture  
 total wattage per fixture  
 total interior wattage specified vs. allowed (whole building or space by space)  
 total exterior wattage specified vs. allowed

**Additional Efficiency Package Options**  
 (When using the 2018 NCCES, not required for ASHRAE 90.1)  
 C406.2 More Efficient Mechanical Equipment  
 C406.3 Reduced Lighting Power Density  
 C406.4 Enhanced Digital Lighting Controls  
 C406.5 On-Site Renewable Energy  
 C406.6 Dedicated Outdoor Air System  
 C406.7 Reduced Energy Use in Service Water Heating

2018 NC Administrative Code and Policies Appendix B for Building

(SECTION 1106)

LEFT OR PARKING AREA	TOTAL # OF PARKING SPACES		# OF ACCESSIBLE SPACES PROVIDED		TOTAL # ACCESSIBLE PROVIDED
	REQUIRED	PROVIDED	MINIMUM WITH 5' ACCESS	MINIMUM WITH 8' ACCESS	
	36	36	0	2	2
TOTAL					

**PLUMBING FIXTURE REQUIREMENTS**  
(TABLE 290.1)

SPACE	EXIST'G	WATER FIXTURES		SINKS		LAVATORIES		SHOWERS / TUBS	DRINKING FOUNTAINS
		MALE	FEMALE	MALE	FEMALE	UNSEX	REGULAR		
NEW	1	1	0	0	1	1	0	0	2
RECY	1	1	0	0	1	1	0	0	2

**SPECIAL APPROVALS**  
 Special approval: (Local Jurisdiction, Department of Insurance, SCO, DPI, DHHS, ICC, etc., describe below)  
 \_\_\_\_\_  
 \_\_\_\_\_  
 \_\_\_\_\_

2018 NC Administrative Code and Policies Appendix B for Building

**ENERGY SUMMARY**

**ENERGY REQUIREMENTS:**  
 The following data shall be considered minimum and any special alternate required to meet the North Carolina Energy Conservation Code shall also be provided. Each Designer shall provide the required portions of the project information for the plan data sheet. If performance method, state the annual energy cost for the standard reference design vs annual energy cost for the proposed design.

Existing building envelope complies with code:  No  Yes (The remainder of this section is not applicable)  
 Exempt Building:  No  Yes (Provide Code or Statute reference) \_\_\_\_\_

**Climate Zone:**  3A  4A  5A

**Method of Compliance:** Energy Code:  Performance  Prescriptive  
 ASHRAE 90.1  Performance  Prescriptive  
 (If "Other" specify source here) \_\_\_\_\_

**THERMAL ENVELOPE (Prescriptive method only)**

**Roof/Ceiling Assembly (each assembly)**  
 Description of assembly: WOOD ATTIC FRAMING  
 U-Value of total assembly: 0.12  
 R-Value of insulation: \_\_\_\_\_  
 Skylights in each assembly: \_\_\_\_\_  
 U-Value of skylight: \_\_\_\_\_  
 Total square footage of skylights in each assembly: \_\_\_\_\_

**Exterior Walls (each assembly)**  
 Description of assembly: WOOD FRAMING  
 U-Value of total assembly: \_\_\_\_\_  
 R-Value of insulation: 20  
 Openings (windows or doors with glazing)  
 U-Value of assembly: \_\_\_\_\_  
 U-Value of glazing: 0.45  
 Solar heat gain coefficient: 0.40  
 Projection factor: 0.50  
 Door R-Value: 6.5

**Walls below grade (each assembly)**  
 Description of assembly: \_\_\_\_\_  
 U-Value of total assembly: N/A  
 R-Value of insulation: \_\_\_\_\_

**Floors over unconditioned space (each assembly)**  
 Description of assembly: \_\_\_\_\_  
 U-Value of total assembly: \_\_\_\_\_  
 R-Value of insulation: \_\_\_\_\_

**Floors slab on grade**  
 Description of assembly: UNHEATED SLAB  
 U-Value of total assembly: \_\_\_\_\_  
 R-Value of insulation: 15  
 Horizontal/Vertical requirement: 24"  
 Slab Height: \_\_\_\_\_

2018 NC Administrative Code and Policies Appendix B for Building

**2018 APPENDIX B  
BUILDING CODE SUMMARY FOR ALL COMMERCIAL PROJECTS  
STRUCTURAL DESIGN  
(PROVIDE ON THE STRUCTURAL SHEETS IF APPLICABLE)**

**DESIGN LOADS:**  
 Importance Factors: Snow (ls) 1.0 Seismic (ls) 1.0  
 Live Loads: Roof 20 psf Mezzanine 100 psf Floor 100 psf  
 Ground Snow Load: 15 psf  
 Wind Load: Ultimate Wind Speed 119 mph (ASCE-7) Exposure Category C

**SEISMIC DESIGN CATEGORY:**  A  B  C  D  
 Provide the following Seismic Design Parameters:  
 Risk Category (Table 1604.5)  I  II  III  IV  V  
 Spectral Response Acceleration  $S_s$  (0.1) 0.15  $S_1$  (0.5) 0.15  $S_{0.1}$  (0.1) 0.15  
 Site Classification (ASCE 7)  A  B  C  D  E  F  
 Data Source:  Field Test  Prescriptive  Historical Data  
 Bearing Wall  Dual w/ Special Moment Frame  
 Building Frame  Dual w/ Intermediate R/C or Special Steel  
 Moment Frame  Inverted Pendulum  
 Simplified  Equivalent Lateral Force  Dynamic  
 Analysis Procedure:  Architectural, Mechanical, Components anchored?  Yes  No

**LATERAL DESIGN CONTROL:** Earthquake  Wind

**SOIL BEARING CAPACITIES:**  
 Field Test (provide copy of test report) 3000 psf  
 Prescriptive Bearing capacity \_\_\_\_\_ psf  
 Pile size, type, and capacity \_\_\_\_\_

2018 NC Administrative Code and Policies Appendix B for Building

**2018 APPENDIX B  
BUILDING CODE SUMMARY FOR ALL COMMERCIAL PROJECTS  
MECHANICAL DESIGN  
(PROVIDE ON THE MECHANICAL SHEETS IF APPLICABLE)**

**MECHANICAL SYSTEMS, SERVICE SYSTEMS AND EQUIPMENT**

**Thermal Zone**  
 winter dry bulb: 16° F  
 summer dry bulb: 92° F

**Interior design conditions**  
 winter dry bulb: 70° F  
 summer dry bulb: 75° F  
 relative humidity: 55%

**Building heating load:** 199,518  
**Building cooling load:** 327,009

**Mechanical Space Conditioning System**  
 Unitary description of unit: PACK A/C W/ ELECT. HT.  
 heating efficiency: 98%  
 cooling efficiency: 11.0 EER  
 size category of unit: 15 TONS EA.  
 Boiler: \_\_\_\_\_  
 Chiller: \_\_\_\_\_  
 Size category: If oversized, state reason: N/A  
 Size category: If oversized, state reason: N/A

**List equipment efficiencies: SEE ABOVE**

Light Type	Lamp Type	# of Lamps	Ballast Type	# of Ballasts	W/P Nature	Total Int. Wattage Specified	Int. Wattage Allowed	Total Est. Wattage Specified	Est. Wattage Specifications
<b>INTERIOR</b>									
A/A1	LED	unknown	N/A	0	1	32	2475	15856	
<b>EXTERIOR</b>									
G	LED	unknown	N/A	0	38			1034	1236
HB/HP	LED	unknown	N/A	0	167			1034	1236

2018 NC Administrative Code and Policies Appendix B for Building

**2018 APPENDIX B  
BUILDING CODE SUMMARY FOR ALL COMMERCIAL PROJECTS  
ELECTRICAL DESIGN  
(PROVIDE ON THE ELECTRICAL SHEETS IF APPLICABLE)**

**ELECTRICAL SYSTEM AND EQUIPMENT**

**Method of Compliance:** Energy Code:  Prescriptive  Performance  
 ASHRAE 90.1:  Prescriptive  Performance

**Lighting Schedule (each fixture type) - SEE BELOW**  
 lamp type required in fixture  
 number of lamps in fixture  
 ballast type used in the fixture  
 number of ballasts in fixture  
 total wattage per fixture  
 total interior wattage specified vs. allowed (whole building or space by space)  
 total exterior wattage specified vs. allowed

**Additional Efficiency Package Options**  
 (When using the 2018 NCCES, not required for ASHRAE 90.1)  
 C406.2 More Efficient Mechanical Equipment  
 C406.3 Reduced Lighting Power Density  
 C406.4 Enhanced Digital Lighting Controls  
 C406.5 On-Site Renewable Energy  
 C406.6 Dedicated Outdoor Air System  
 C406.7 Reduced Energy Use in Service Water Heating

2018 NC Administrative Code and Policies Appendix B for Building

**JOHN P. WATKINS, ARCHITECT**  
 56 HILLMARK DRIVE  
 COLUMBIA, SOUTH CAROLINA 29210

**Craig A. Otto**  
 ARCHITECT, INC.

DESIGN • PLANNING • ARCHITECTURE

5044 Augusta Road  
 Lexington, South Carolina 29072  
 Phone (803) 957-9004  
 Fax (803) 957-2050

No.	Revisions	Date
1	ADDED SHEET "LS2"	1/8/22

All rights reserved. This drawing and the design shown thereon are copyrighted as prescribed by the laws of the United States and are the sole property of Craig A. Otto, Architect, Inc. Anyone duplicating, reproducing, or causing to be reproduced these drawings or the design thereon without permission of the architect will be subject to legal action.

Project Title: **DOLLAR GENERAL #23725**  
 US 421 S, LILLINGTON, NC

Drawing Title: **APPENDIX B**

Consultant: \_\_\_\_\_

Seal: 

Date: **DECEMBER 8, 2021**  
 Drawn By: **OTTO**  
 Drawing No.: **LS2**

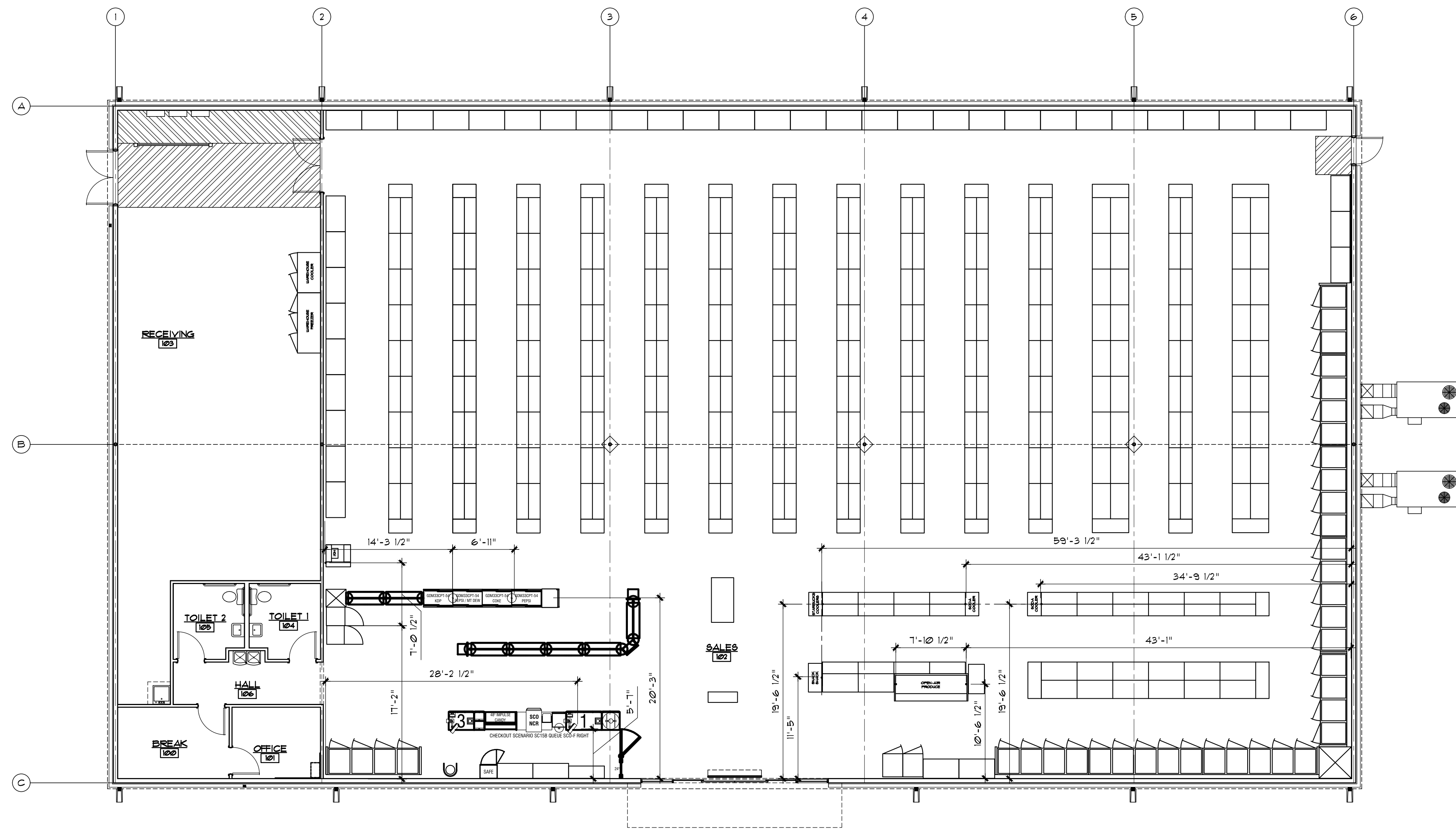

NOTE:  
CONSULT DOLLAR GENERAL STORE DESIGN DEPARTMENT TO DETERMINE WHICH FIXTURE PLAN TO UTILIZE, EITHER CONCENTRIC STORE OR SELECT DESIGN.

NOTE:  
• MAINTAIN INTERIOR MINIMUM CLEARANCE OF 14'-8" BETWEEN GYPSUM BOARD  
• ANY DEVIATIONS FROM THE ABOVE DIMENSIONS SHALL IMMEDIATELY BE BROUGHT TO THE ATTENTION OF THE ARCHITECT.

NOTE:  
THE CLEAR DISTANCE BETWEEN THE BACK OF THE SALES FIXTURES AND THE BACK OF THE GYPSUM BOARD SHALL NOT EXCEED 1 1/2". IF GREATER THAN 1 1/2", FURRING STRIPS SHALL BE INSTALLED TO THE FACE OF THE GYPSUM BOARD. TOP OF STRIPS AT 18" AFF. PAINT TO MATCH WALL.

NOTE:  
• COORDINATE THE LOCATIONS OF ALL THE COOLERS AND FREEZERS INCLUDING GATORADE AND ICE CREAM AND BEVERAGE ANCHOR BOARD WITH THE CURRENT DG FIXTURE PLAN  
• COORDINATE THE FINAL LOCATION AND NUMBER OF REGISTERS WITH THE APPROVED FIXTURE PLAN.

1  
FI.1  
FIXTURE PLAN (DGP21-C)  
SCALE: 1/8" = 1' - 0"

NOTE:  
• VERIFY WITH FINAL FIXTURE PLAN  
• COORDINATE POWER LOCATIONS WITH FINAL FIXTURE PLAN

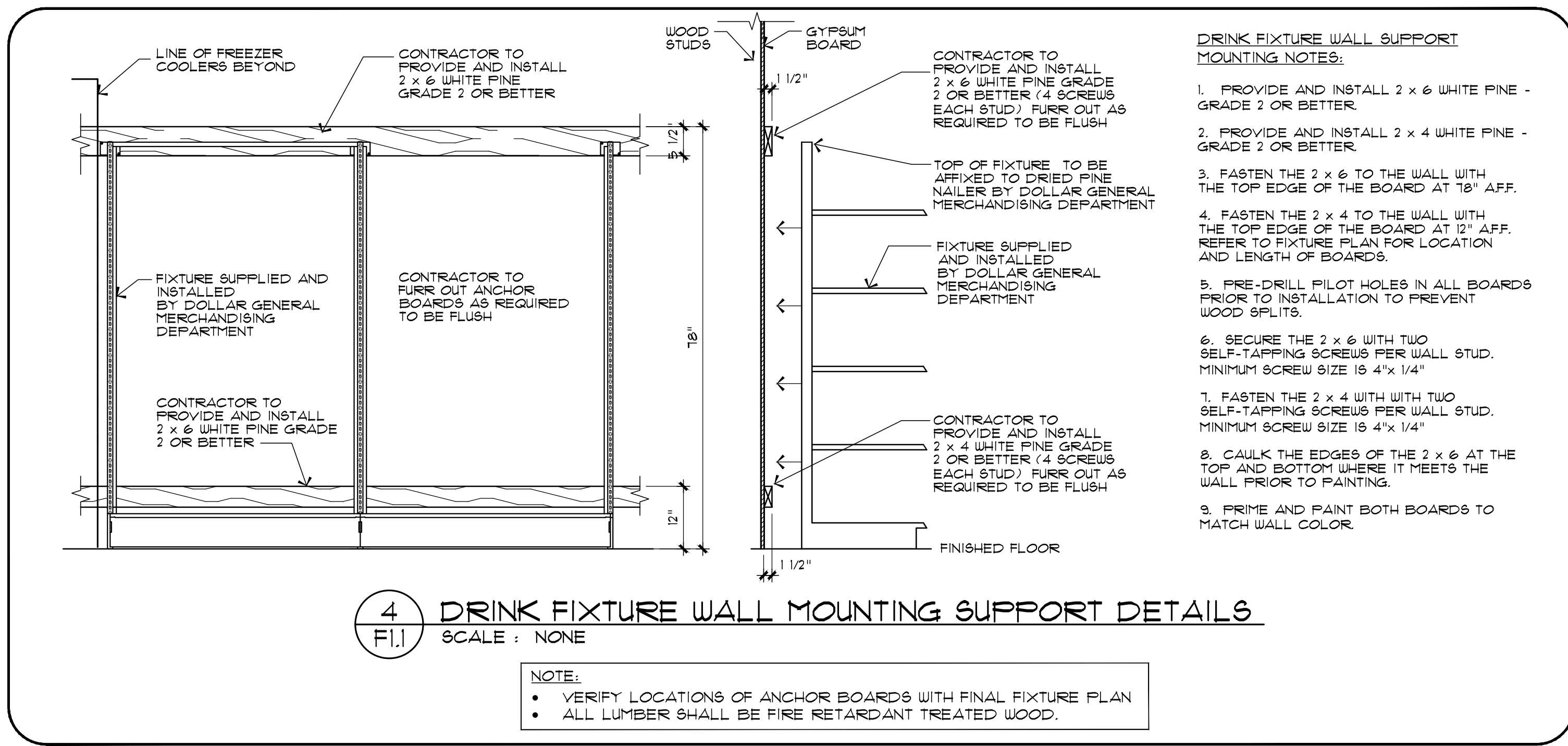

4  
FI.1  
DRINK FIXTURE WALL MOUNTING SUPPORT DETAILS  
SCALE: NONE

NOTE:  
• VERIFY LOCATIONS OF ANCHOR BOARDS WITH FINAL FIXTURE PLAN  
• ALL LUMBER SHALL BE FIRE RETARDANT TREATED WOOD.

DRINK FIXTURE WALL SUPPORT MOUNTING NOTES:  
1. PROVIDE AND INSTALL 2 x 6 WHITE PINE - GRADE 2 OR BETTER.  
2. PROVIDE AND INSTALL 2 x 4 WHITE PINE - GRADE 2 OR BETTER.  
3. FASTEN THE 2 x 6 TO THE WALL WITH THE TOP EDGE OF THE BOARD AT 18" AFF.  
4. FASTEN THE 2 x 4 TO THE WALL WITH THE TOP EDGE OF THE BOARD AT 12" AFF. REFER TO FIXTURE PLAN FOR LOCATION AND LENGTH OF BOARDS.  
5. PRE-DRILL PILOT HOLES IN ALL BOARDS PRIOR TO INSTALLATION TO PREVENT WOOD SPLITS.  
6. SECURE THE 2 x 6 WITH TWO SELF-TAPPING SCREWS PER WALL STUD. MINIMUM SCREW SIZE IS 4"x 1/4".  
7. FASTEN THE 2 x 4 WITH TWO SELF-TAPPING SCREWS PER WALL STUD. MINIMUM SCREW SIZE IS 4"x 1/4".  
8. CAULK THE EDGES OF THE 2 x 6 AT THE TOP AND BOTTOM WHERE IT MEETS THE WALL PRIOR TO PAINTING.  
9. PRIME AND PAINT BOTH BOARDS TO MATCH WALL COLOR.

JOHN P. WATKINS, ARCHITECT  
56 HILLMARK DRIVE  
COLUMBIA, SOUTH CAROLINA 29210

**Craig A. Otto**  
ARCHITECT, INC.

DESIGN • PLANNING • ARCHITECTURE

5044 Augusta Road  
Lexington, South Carolina 29072  
Phone (803) 957-9004  
Fax (803) 957-2050

No.	Revisions	Date

All rights reserved. This drawing and the design shown thereon are copyrighted as prescribed by the laws of the United States and are the sole property of Craig A. Otto, Architect, Inc. Anyone duplicating, reproducing, or causing to be reproduced these drawings or the design thereon without permission of the architect will be subject to legal action.

Project Title **DOLLAR GENERAL #23725**  
US 421 S, LILLINGTON, NC

Drawing Title **FIXTURE PLAN AND DETAILS**

Consultant

Seal

Date  
DECEMBER 8, 2021  
Drawn By  
OTTO  
Drawing No.  
**FI.1**

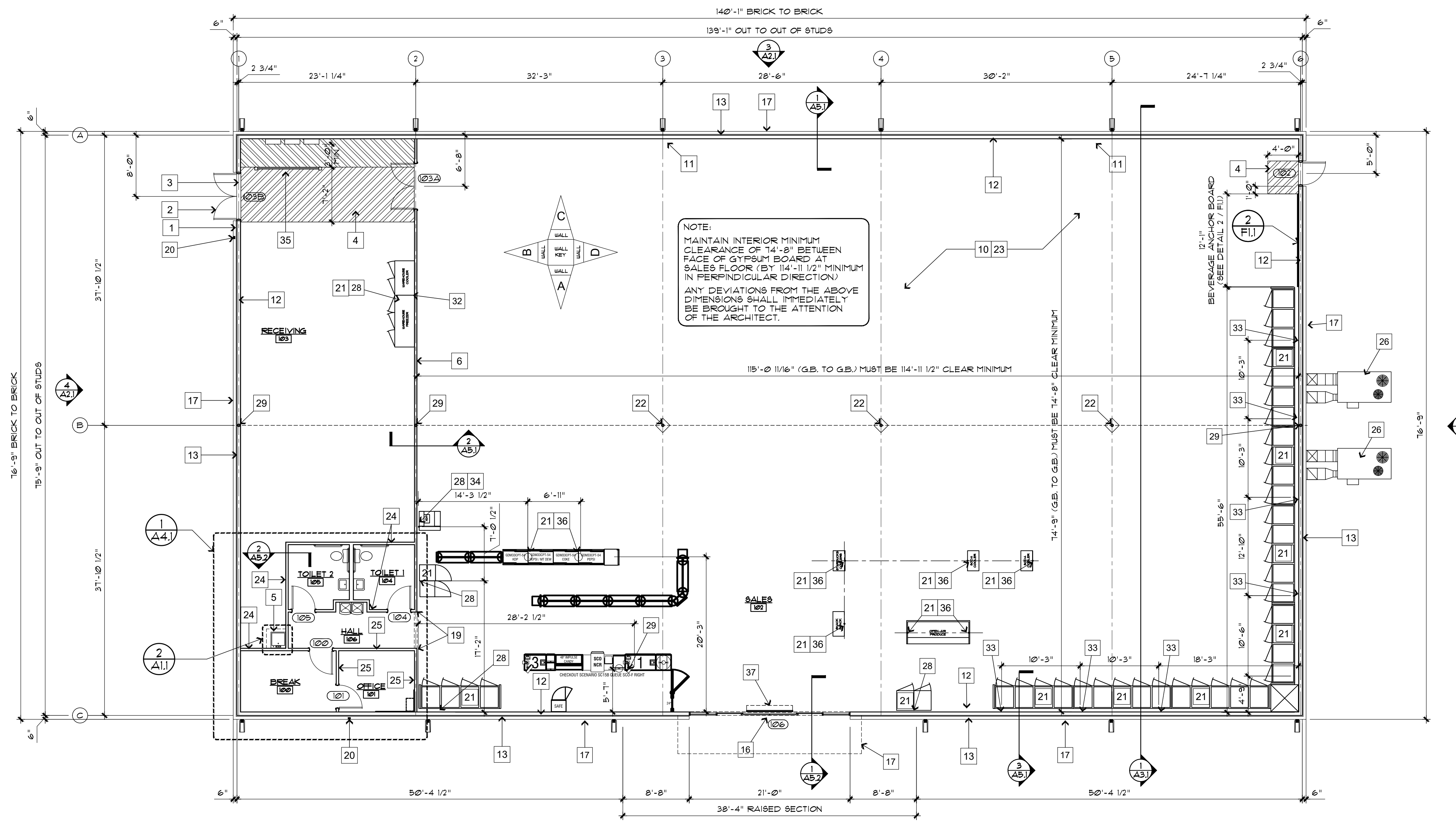

**1 ARCHITECTURAL FLOOR PLAN (DGP21-C)**  
 SCALE: 1/8" = 1' - 0"  
 10,751 SQUARE FEET

**KEYED NOTES**

- 1 RECEIVING DOOR BUZZER.
- 2 2" DOOR SCOPE.
- 3 WEATHERSTRIP AND LOW PROFILE THRESHOLD PROVIDED BY BASS SECURITY. REFER TO DOOR SCHEDULE.
- 4 STRIPE FLOOR FOR DESIGNATED EGRESS PATH (FAINT YELLOW) AND DESIGNATED EGRESS PANEL CLEARANCE (FAINT RED).
- 5 PROVIDE AND INSTALL A MIN. 10 GALLON WATER HEATER ON A SHELF ABOVE THE MOP SINK. REFER TO THE PLUMBING PLANS.
- 6 2 x 6 INTERIOR STUD RECEIVING WALL WITH GYPSUM BOARD EACH SIDE. SEE STRUCTURAL.
- 7 NOT USED.
- 8 NOT USED.
- 9 NOT USED.
- 10 4" THICK CONCRETE SLAB WITH 6 x 6 x 14 WELDED WIRE MESH REINFORCEMENT OVER 10 MIL POLYETHYLENE VAPOR BARRIER OVER COMPACTED EARTH. SEE STRUCTURAL PLANS.
- 11 NOT USED.
- 12 2 x 6 EXTERIOR STUD WALL TO TRUSSES ABOVE. STUDS TO BE SPACED PER STRUCTURAL REQUIREMENTS. INCLUDE INSULATION WITH VAPOR BARRIER.
- 13 4" NOMINAL BRICK VENEER WAINSCOT UP TO 4'-0" AFF. WITH FIBER CEMENT BOARD HORIZONTAL SIDING ABOVE SECURED TO PLYWOOD SHEATHING.
- 14 SLOPE CONCRETE 1/8" PER FOOT AWAY FROM BUILDING.
- 15 CONCRETE SIDEWALK BROOM FINISH TYPICAL. COORDINATE WITH CIVIL PLANS.
- 16 BRONZE AUTOMATIC OPENING DOOR STOREFRONT SYSTEM. SEE DOOR SCHEDULE FOR SIZE. CONTINUE GYPSUM BOARD ABOVE DOOR TO ROOF DECK AT INTERIOR SALES AREA DOOR.
- 17 LINE OF ROOF OVERHANG (6") OR CANOPY ABOVE.
- 18 A.D.A. COMPLIANT ACCESSIBLE RAMP WITH YELLOW PAINTED SIDES TO ACCESSIBLE PARKING SPACES. SEE CIVIL DRAWINGS.
- 19 MC CUE CART AND BUMPER GUARDS. INSTALL TOP AT 3'-5" AFF. ORDER TRIM KIT FOR THIS PROTOTYPE.
- 20 WALL HYDRANT. REFER TO PLUMBING DRAWING FOR ADDITIONAL INFORMATION.
- 21 REFRIGERATION BY DOLLAR GENERAL.
- 22 INTERIOR ROUND (SQUARE IS NOT ACCEPTABLE) STEEL COLUMN RECESSED UNDER CONCRETE SLAB. PROVIDE 16" x 16" KNOCKOUTS IN THE SLAB FOR THE COLUMN INSTALLATION. SEE THE STRUCTURAL DRAWINGS. STAIN THE KNOCKOUT AREA BLACK WRAP BOTTOM 4'-0" OF COLUMN WITH BLACK TIGHT LOOP CARPET. PAINT REMAINDER OF STEEL COLUMN SMOOTH PURE WHITE.
- 23 CONTROL JOINTS SHALL BE LOCATED ALONG COLUMN LINES AND MID POINT BETWEEN COLUMN LINES. SEE THE STRUCTURAL DRAWINGS.
- 24 2 x 4 INTERIOR STUD WALLS WITH 1/2" GYPSUM BOARD EACH SIDE. PROVIDE 2 x 6 STUDS FOR PLUMBING WASTE PIPING. EXTEND WALL TO THE BOTTOM OF TRUSSES ABOVE.
- 25 2 x 4 INTERIOR STUD WALLS WITH 1/2" GYPSUM BOARD TO 10'-0" AFF WITH PAINTED ALUMINUM CAP.
- 26 HVAC UNIT ON CONCRETE PAD. REFER TO MECHANICAL DRAWINGS FOR ADDITIONAL INFORMATION.
- 27 POWER POLE. COORDINATE FINAL LOCATION WITH FINAL DOLLAR GENERAL FIXTURE PLAN. REFER TO ELECTRICAL SHEETS.
- 28 REFRIGERATION AND NON-REFRIGERATION EQUIPMENT ON WALLS TO BE POWERED THROUGH OUTLETS. SEE ELECTRICAL. COORDINATE LOCATIONS WITH FINAL FIXTURE PLAN.
- 29 INCLUDE STEEL COLUMNS IN WALLS PER STRUCTURAL TO SUPPORT ENDS OF CENTRAL BEAM.
- 30 NOT USED.
- 31 NOT USED.
- 32 MAINTAIN 2" AIR SPACE GAP BETWEEN THE REACH-IN COOLER / FREEZER AND THE WALL FOR VENTILATION.
- 33 WALL OUTLETS FOR BANKS OF COOLERS AND FREEZERS. SEE ELECTRICAL FOR DETAILS. OUTLETS TO BE 11" FROM RIGHT SIDE OF UNITS AS YOU FACE THEM FROM THE SALES FLOOR.
- 34 NON-REFRIGERATION EQUIPMENT (REGISTERS, HIGH KIOSK, ATM, KEYME) BY DOLLAR GENERAL.
- 35 MC CUE RAILING IN FRONT OF ELECTRICAL PANELS. 8'-0" LONG WITH TOP TWO RAILINGS AND NO MIDDLE POST.
- 36 FREESTANDING COOLER/FREEZERS (INCLUDING DISPLAY LIGHTING) TO BE HARDWIRED THROUGH WHITE 80 CORD. GO TO LEAVE BOTTOM HANGING AT 20" AFF. (SEE ELECTRICAL). CORD ANCHORED TO FURLINS ABOVE. COORDINATE LOCATION WITH FINAL DOLLAR GENERAL FIXTURE PLAN.
- 37 AIR CURTAIN: SEE MECHANICAL DRAWINGS. USE 2x8 x 6" BLOCKING AS REQUIRED TO MOUNT AIR CURTAIN.

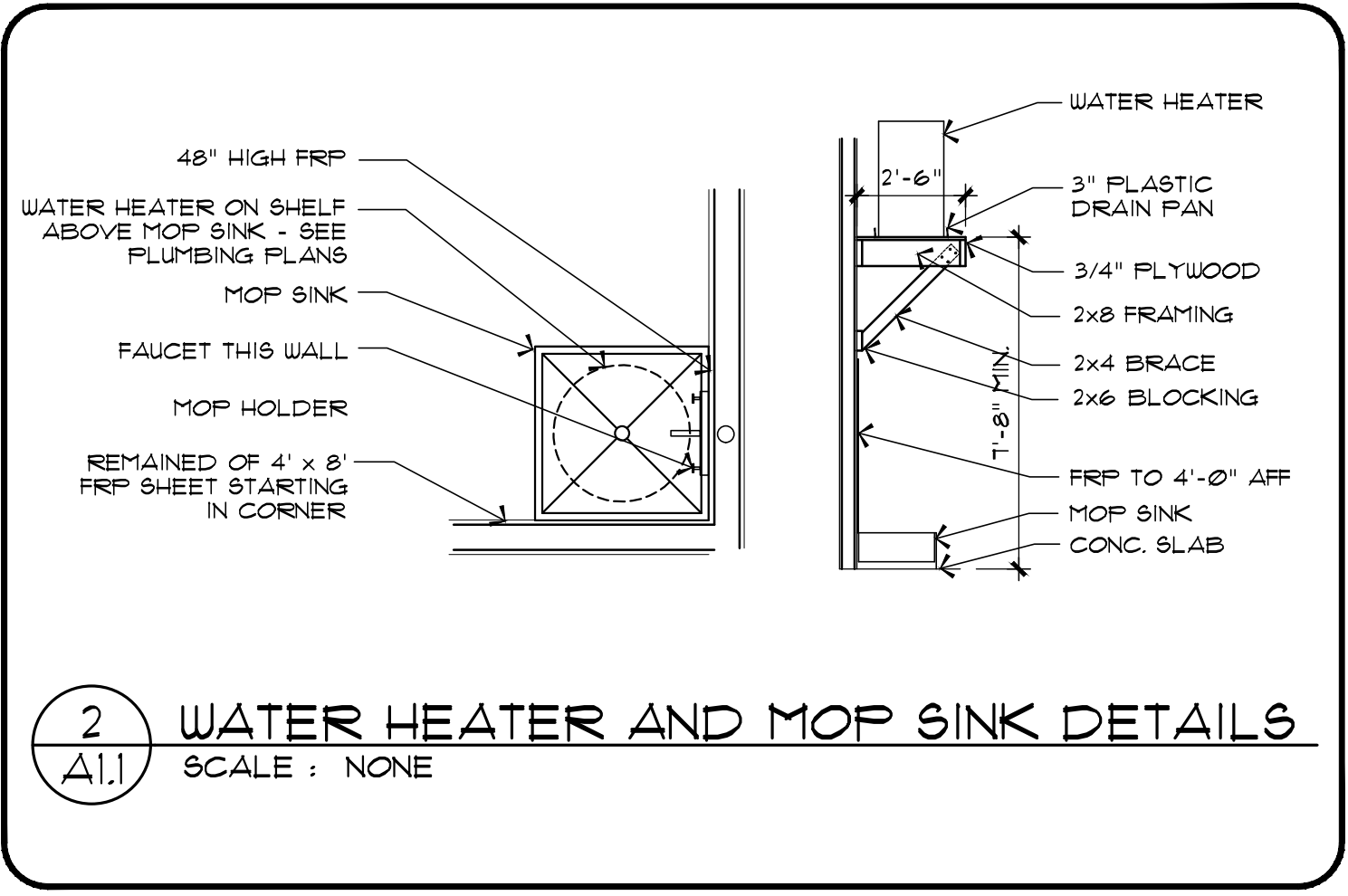

**4 JOB SITE SIGN DETAIL**  
 SCALE: NONE

**JOHN P. WATKINS, ARCHITECT**  
 56 HILLMARK DRIVE  
 COLUMBIA, SOUTH CAROLINA 29210

**Craig A. Otto**  
 ARCHITECT, INC.  
 DESIGN • PLANNING • ARCHITECTURE

5044 Augusta Road  
 Lexington, South Carolina 29072  
 Phone (803) 957-9004  
 Fax (803) 957-2050

No.	Revisions	Date

All rights reserved. This drawing and the design shown thereon are copyrighted as prescribed by the laws of the United States and are the sole property of Craig A. Otto, Architect, Inc. Anyone duplicating, reproducing, or causing to be reproduced these drawings or the design thereon without permission of the architect will be subject to legal action.

Project Title **DOLLAR GENERAL #23725**  
 US 421 S, LILLINGTON, NC

Drawing Title **FLOOR PLAN AND DETAILS**

Consultant

Seal  
  
 Date **DECEMBER 8, 2021**  
 Drawn By **OTTO**  
 Drawing No. **A1.1**

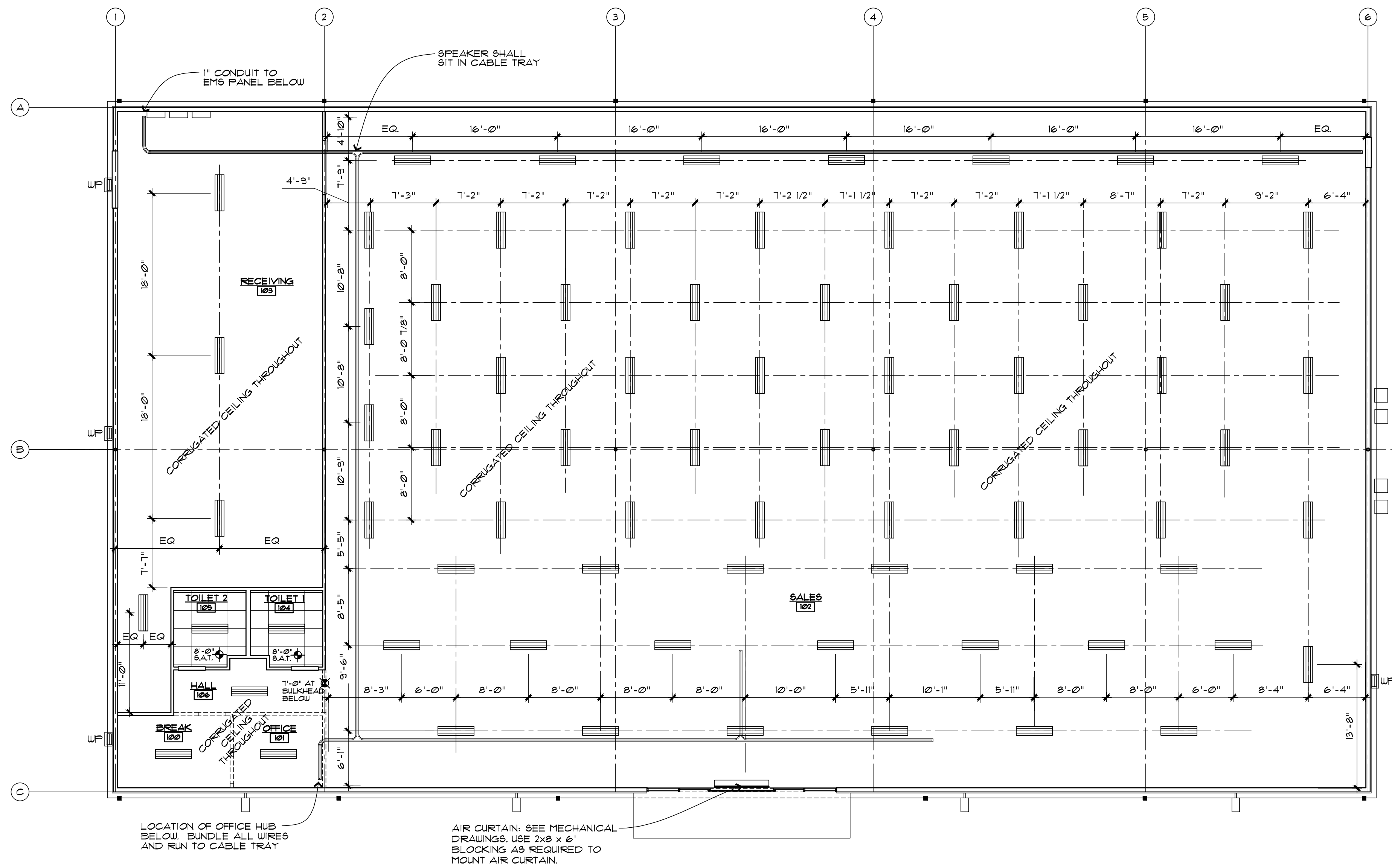

**1 REFLECTED CEILING PLAN**  
 SCALE: 1/8" = 1' - 0"

COORDINATE POWER LOCATIONS WITH FINAL FIXTURE PLAN

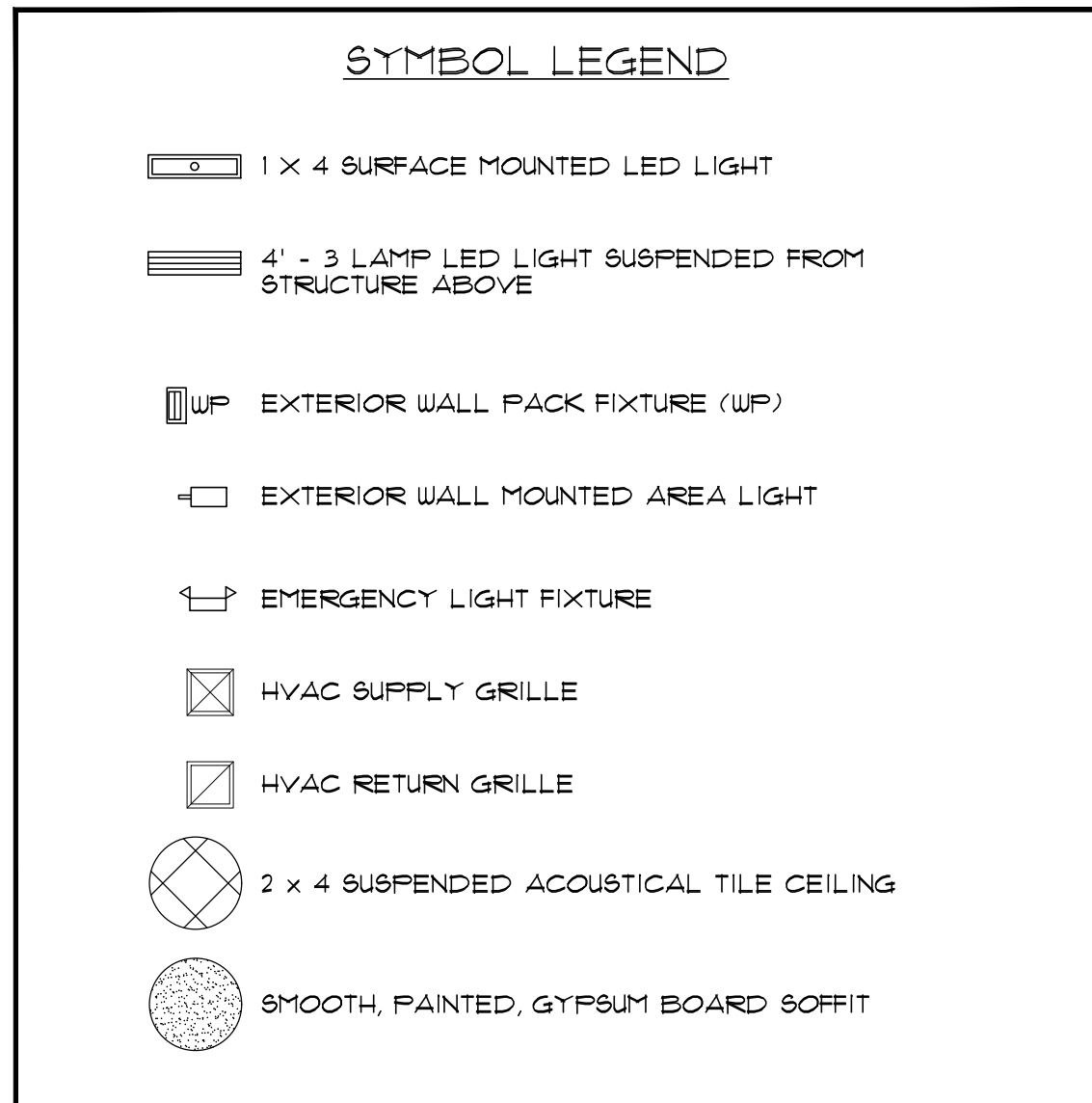

- GENERAL NOTES:**
- ALL LIGHTS SHALL BE MOUNTED SUCH THAT THE TOP OF THE FIXTURES ARE 11'-0" AFF.
  - CABLE TRAY SHALL BE MOUNTED SUCH THAT THE BOTTOM OF THE TRAY IS 11'-6" AFF.
  - CABLE TRAY SYSTEM SHALL BE INSTALLED USING FULL LENGTHS WITH MINIMAL CUTTING OF SECTIONS.
  - THE GENERAL CONTRACTOR SHALL PROVIDE AND INSTALL THE CABLE TRAY AND ALL CONDUIT WITH FULL STRINGS AS NOTED.
  - BULKHEADS SHALL BE FRAMED USING 3 5/8" 20 GAUGE METAL STUDS AT 16" O.C. WITH SMOOTH PAINTED GYPSUM BOARD
  - SEE FINISH SCHEDULE SHEET FOR ALL CEILING TYPES
  - SEE MECHANICAL AND ELECTRICAL DRAWINGS FOR ADDITIONAL INFORMATION
  - IF A DISCREPANCY OCCURS BETWEEN THE ARCHITECTURAL DRAWINGS AND THE ENGINEERING DRAWINGS, CONSULT THE ARCHITECT PRIOR TO PROCEEDING

NOTE 1: PROVIDE 1" CONDUIT FROM OFFICE, HOLDING CONDUIT TIGHT TO STRUCTURE. WAF MOUNTED AT 12'-0" AFF. CENTERED IN SALES AREA. GENERAL CONTRACTOR SHALL VERIFY INSTALLATION OF JUNCTION BOX AT END OF CONDUIT

NOTE 2: CENTER CABLE TRAY ON ENTRY DOORS. TRAY SECTION TO ACCOMMODATE CCTV LOCATION.

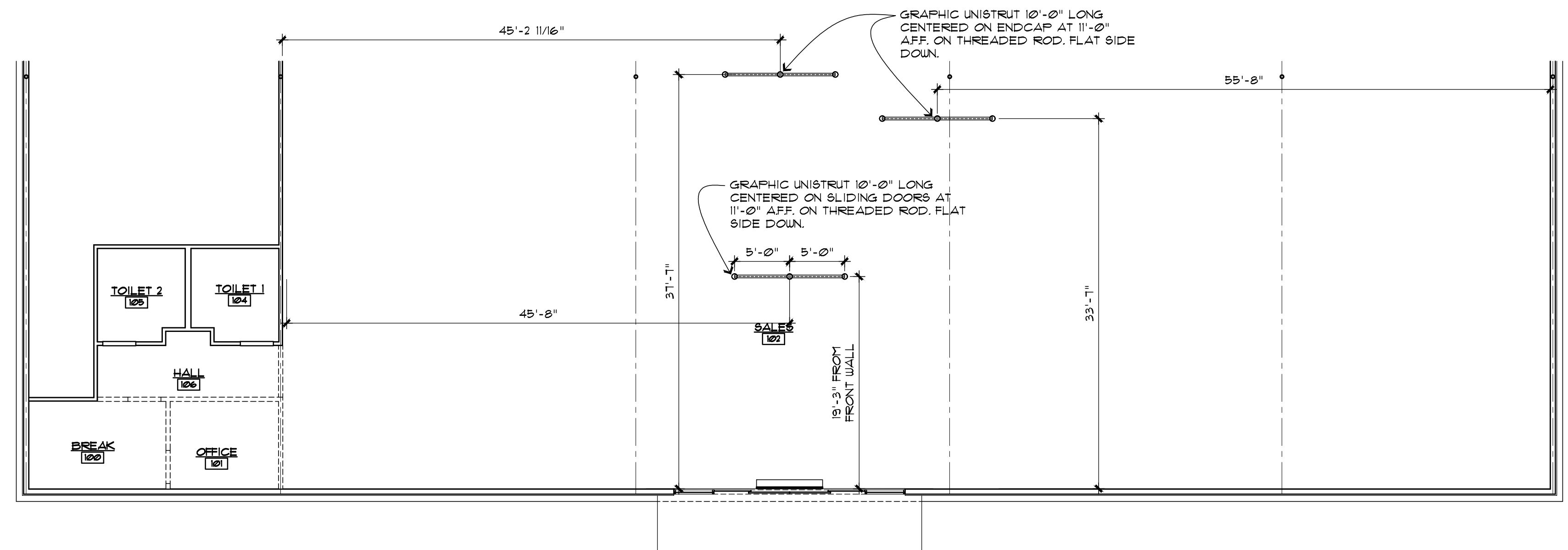

**2 UNISTRUT LOCATIONS FOR SIGNAGE**  
 SCALE: 1/8" = 1' - 0"

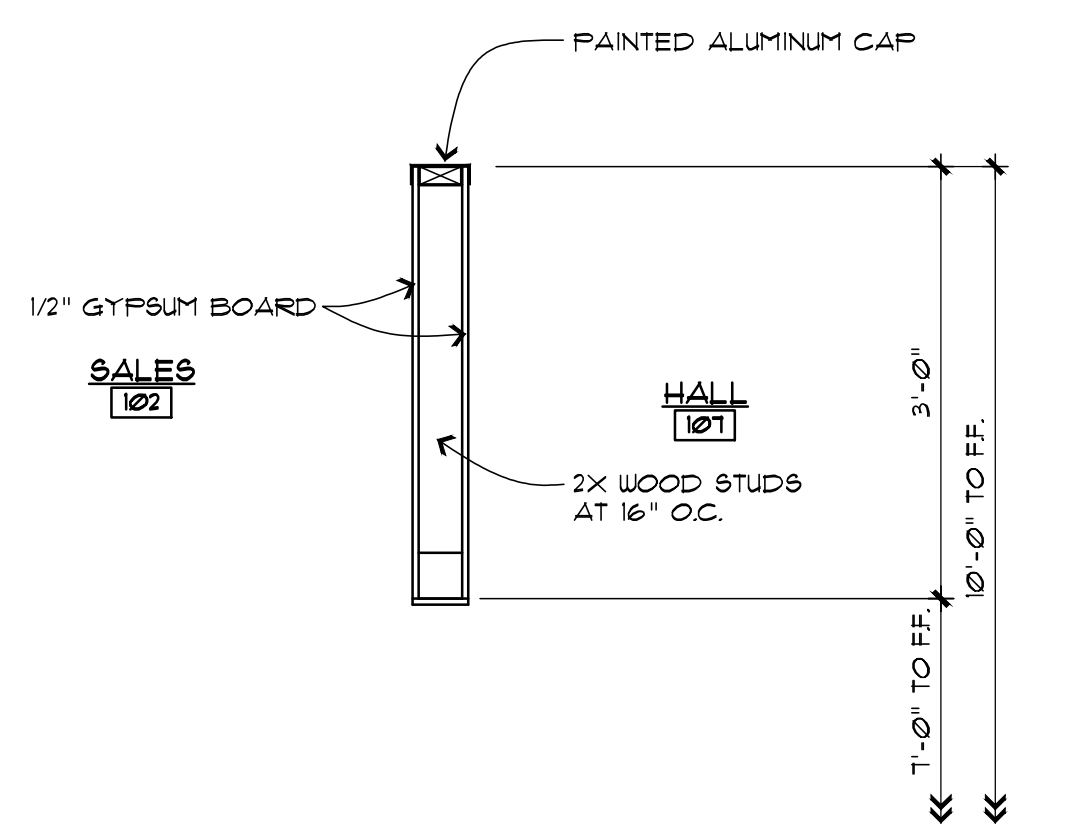

**3 DETAIL AT BULKHEAD**  
 SCALE: 3/4" = 1' - 0"

JOHN P. WATKINS, ARCHITECT  
 56 HILLMARK DRIVE  
 COLUMBIA, SOUTH CAROLINA 29210

**Craig A. Otto**  
 ARCHITECT, INC.

DESIGN • PLANNING • ARCHITECTURE

5044 Augusta Road  
 Lexington, South Carolina 29072  
 Phone (803) 957-9004  
 Fax (803) 957-2050

No.	Revisions	Date

All rights reserved. This drawing and the design shown thereon are copyrighted as prescribed by the laws of the United States and are the sole property of Craig A. Otto, Architect, Inc. Anyone duplicating, reproducing, or causing to be reproduced these drawings or the design thereon without permission of the architect will be subject to legal action.

Project Title **DOLLAR GENERAL #23725**  
 US 421 S, LILLINGTON, NC

Drawing Title **REFLECTED CEILING PLAN**

Consultant

Seal:

Date: **DECEMBER 8, 2021**  
 Drawn By: **OTTO**  
 Drawing No.: **A1.2**

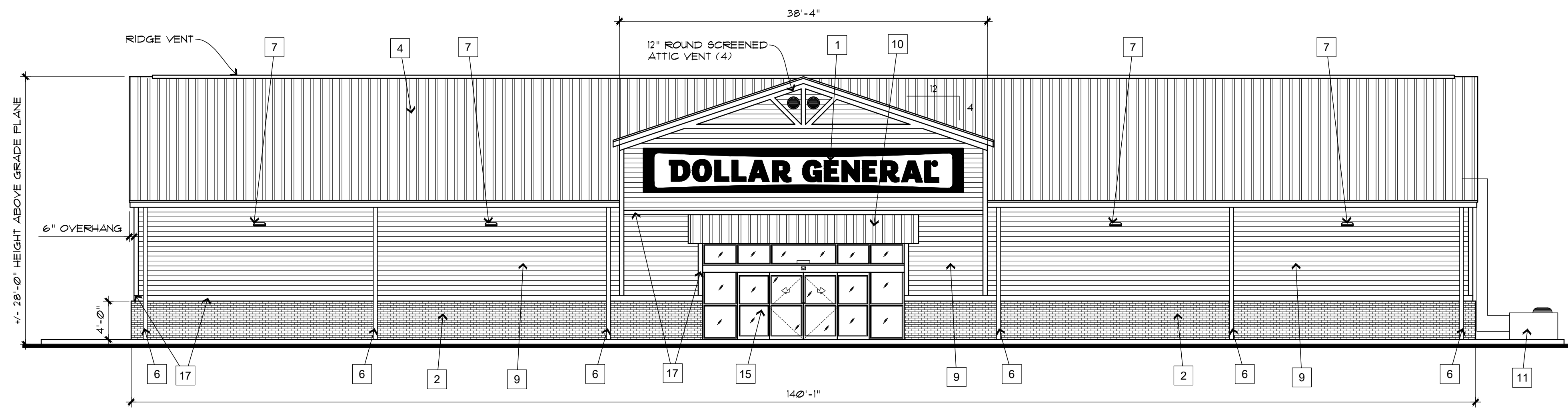

1 FRONT ELEVATION  
SCALE: 1/8" = 1' - 0"

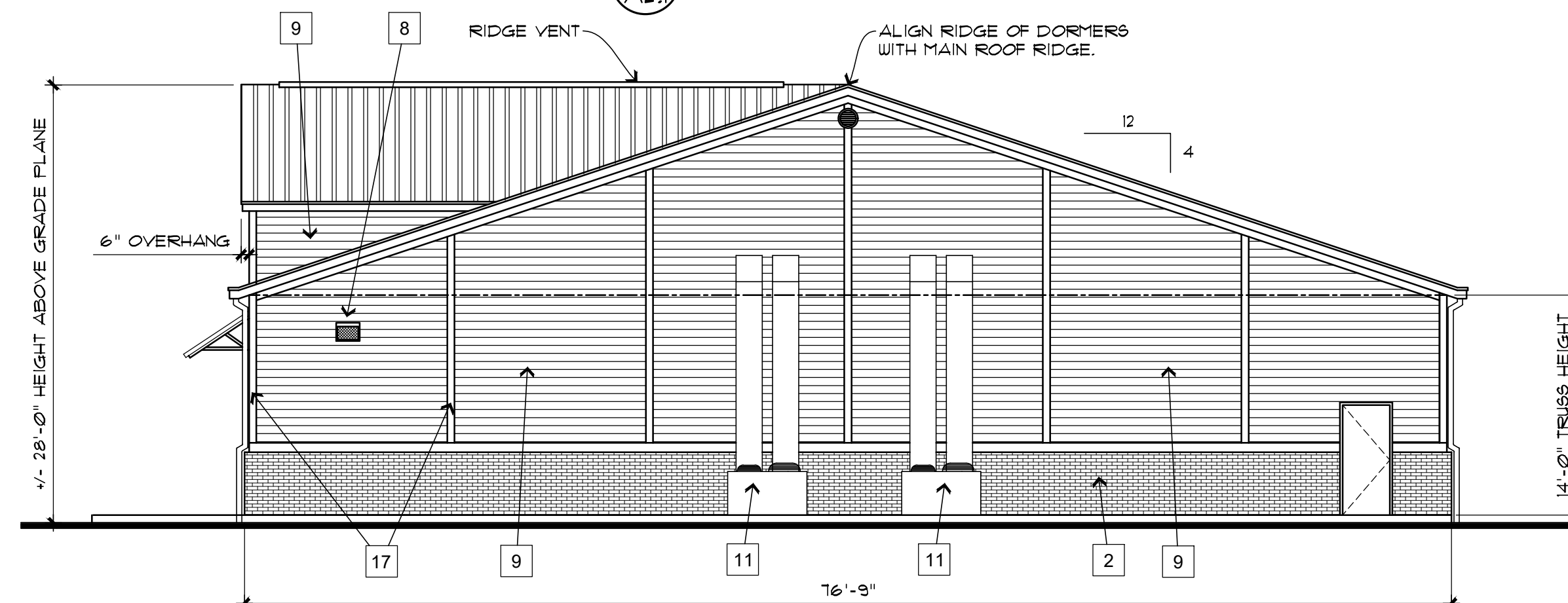

2 RIGHT ELEVATION  
SCALE: 1/8" = 1' - 0"

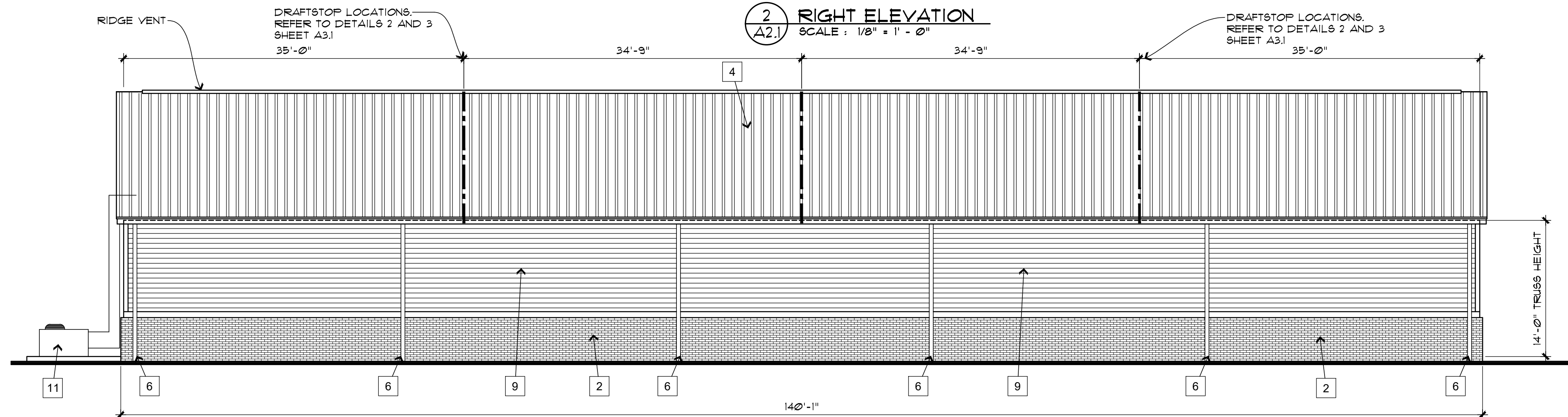

3 REAR ELEVATION  
SCALE: 1/8" = 1' - 0"

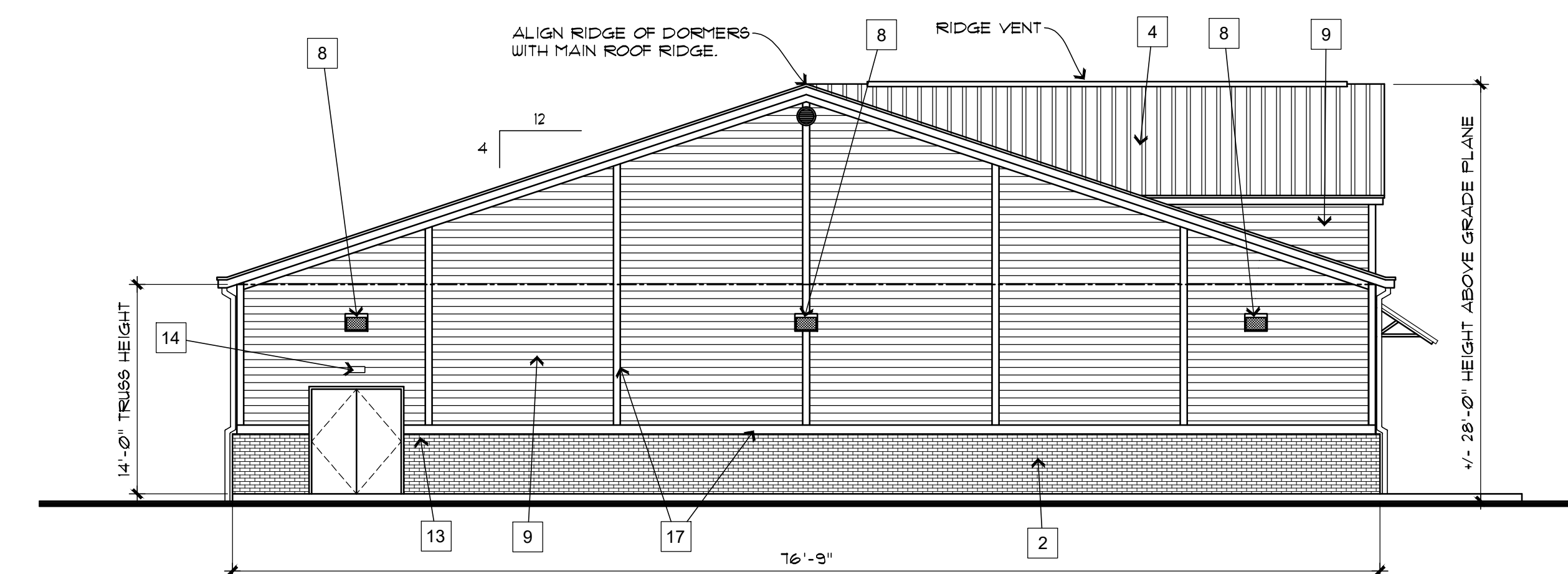

4 LEFT ELEVATION  
SCALE: 1/8" = 1' - 0"

KEYED NOTES

- 1 SIGN FURNISHED AND INSTALLED BY DOLLAR GENERAL CORP. WITH CIRCUIT AS NOTED ON ELECTRICAL PLAN. SIGN SHALL BE CENTERED ON FRONT OF BUILDING. CONTRACTOR SHALL PROVIDE ADEQUATE BLOCKING AS REQUIRED BY SIGN MANUFACTURER TO SUPPORT SIGN WEIGHT OF UP TO 1400 POUNDS. SIGN SHALL BE SUPPORTED BY THE FACE OF THE CANOPY. COORDINATE THE PROPER SIZE OF SIGNAGE TO BE USED WITH DOLLAR GENERAL.
- 2 4" NOMINAL BRICK VENEER WAINSCOT UP TO 4'-0" AFF. SECURED TO PLYWOOD SHEATHING WITH ADJUSTABLE TYPE MASONRY ANCHORS AT 2'-0" O.C. VERTICALLY AND 16" O.C. HORIZONTALLY. BRICK SHALL BE OLD SAVANNAH BRICK WITH LAFARGE SANTAN MORTAR.
- 3 NOT USED
- 4 SCREW DOWN METAL ROOF PANELS PAINTED BURNISHED SLATE.
- 6 GUTTERS AND DOWNSPOUTS IN "AGED BRONZE" FINISH. ALL DOWNSPOUTS DISCHARGING IN NON-PAVED AREAS ARE TO HAVE MINIMUM 4 FOOT LONG PERFORATED LANDSCAPE PIPE STRAPPED TO A 12" x 24" CONCRETE SPLASH BLOCK.
- 7 AREA LIGHT 12'-0" AFF AT CENTERLINE OF CONNECTION TO WALL. REFER TO ELECTRICAL DRAWINGS FOR ADDITIONAL INFORMATION.
- 8 WALL PACK, 12'-0" AFF TO TOP OF WALL PACK. REFER TO ELECTRICAL DRAWINGS FOR ADDITIONAL INFORMATION.
- 9 FIBER CEMENT BOARD HORIZONTAL SIDING SECURED TO PLYWOOD SHEATHING. PAINT SW 6107 NOMADIC DESERT.
- 10 AWNING OVER STOREFRONT WITH METAL CANOPY ROOF. PROVIDE SCREW DOWN BRONZE METAL ROOF PANELS
- 11 HVAC UNIT ON CONCRETE PAD. REFER TO MECHANICAL DRAWINGS FOR ADDITIONAL INFORMATION AND REQUIRED HEIGHT.
- 12 VENT FOR BATHROOM EXHAUST. REFER TO MECHANICAL DRAWINGS. PAINT TO MATCH METAL WALL PANEL COLOR.
- 13 DOOR BUZZER. REFER TO ELECTRICAL DRAWING FOR ADDITIONAL INFORMATION.
- 14 OUTSIDE AIR TEMP. SENSOR MOUNTED OVER RECEIVING DOORS AT 8'-0" AFF.
- 15 AUTOMATIC DOOR AND WINDOW STOREFRONT SYSTEM IN BRONZE FINISH.
- 16 FINISH GRADE SHALL BE A MINIMUM OF 6" BELOW FINISHED FLOOR LEVEL AT ALL NON-PAVED AREAS.
- 17 PAINTED TRIM BOARDS IN TREATED WOOD MATERIAL OR FIBER CEMENT BOARD (CONTRACTOR'S OPTION). PAINT SW 6112 BISCUIT.

JOHN P. WATKINS, ARCHITECT  
56 HILLMARK DRIVE  
COLUMBIA, SOUTH CAROLINA 29210

**Craig A. Otto**  
ARCHITECT, INC.

DESIGN • PLANNING • ARCHITECTURE

5044 Augusta Road  
Lexington, South Carolina 29072  
Phone (803) 957-9004  
Fax (803) 957-2050

No.	Revisions	Date

All rights reserved. This drawing and the design shown thereon are copyrighted as prescribed by the laws of the United States and are the sole property of Craig A. Otto, Architect, Inc. Anyone duplicating, reproducing, or causing to be reproduced these drawings or the design thereon without permission of the architect will be subject to legal action.

Project Title **DOLLAR GENERAL #23725**  
US 421 S, LILLINGTON, NC

Drawing Title  
**EXTERIOR ELEVATIONS**

Consultant

Seal  
  
Date  
DECEMBER 8, 2021  
Drawn By  
OTTO  
Drawing No.  
**A2.1**



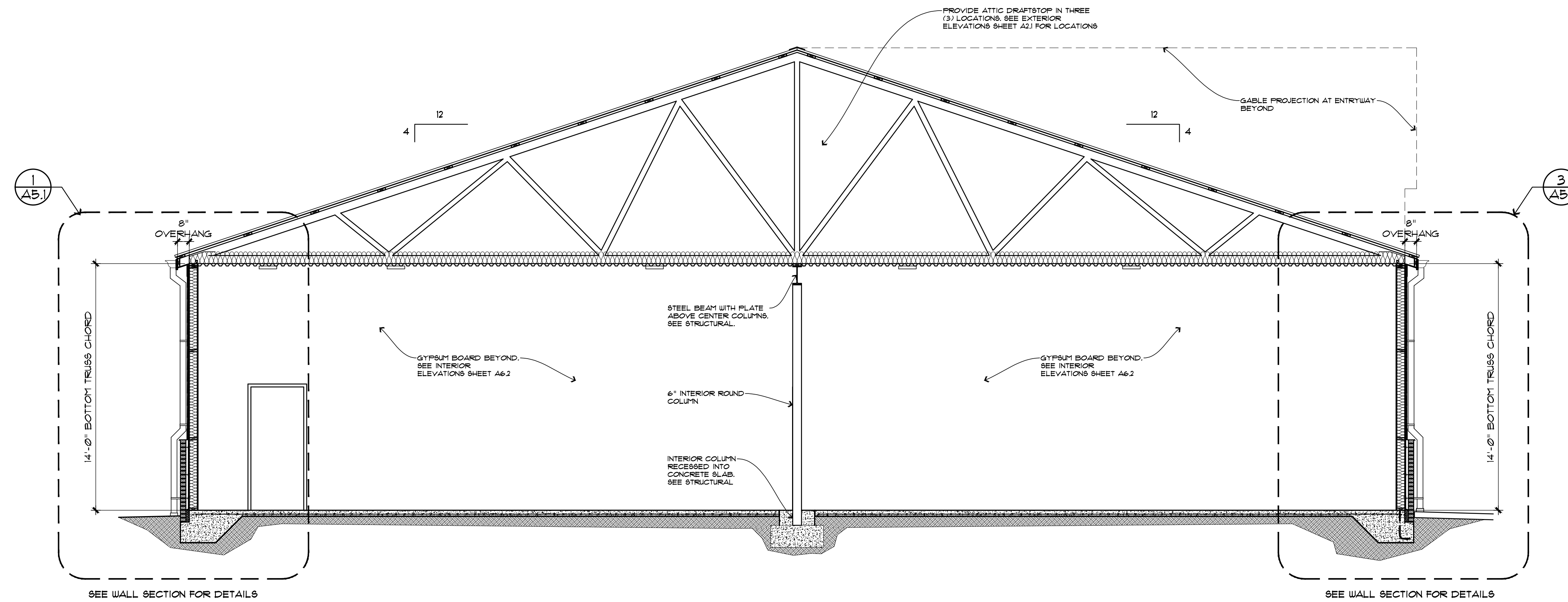

1 TYPICAL BUILDING SECTION  
SCALE: 1/4" = 1' - 0"

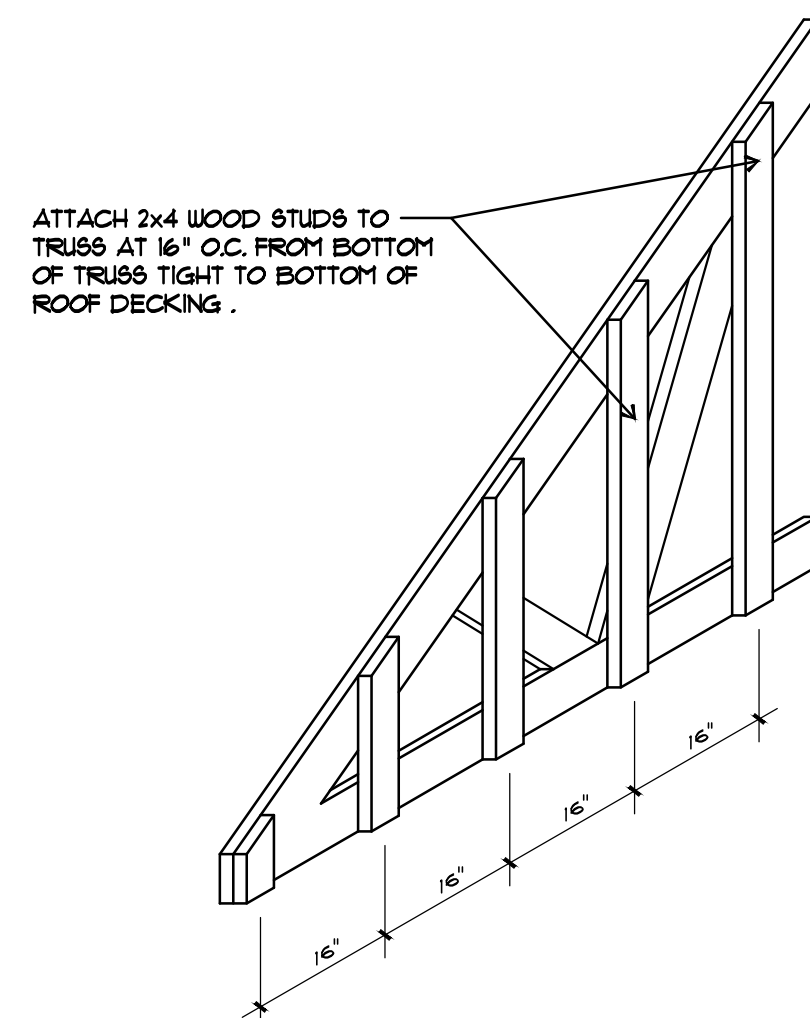

2 DRAFTSTOP BLOCKING DETAIL  
SCALE: NONE

CONTRACTOR'S OPTION TO PROVIDE ENGINEERED GABLE END TRUSS OFFERING COMPARABLE SCREW ATTACHMENT PATTERN AT DRAFTSTOPPING LOCATION. PROVIDE 3'-0" x 3'-0" HINGED PLYWOOD ACCESS DOOR AT EACH DRAFTSTOP.

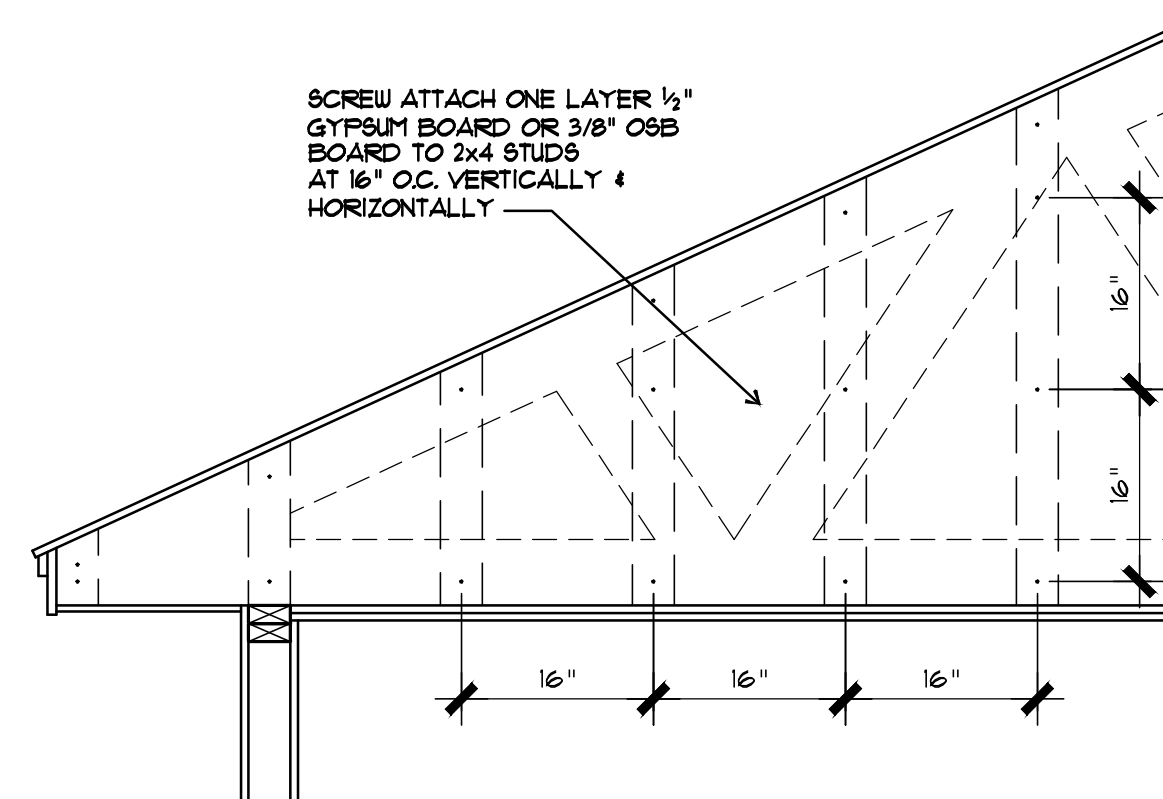

3 SCREW ATTACHMENT PATTERN  
SCALE: NONE

PROVIDE 3'-0" x 3'-0" HINGED PLYWOOD ACCESS DOOR AT EACH DRAFTSTOP.

**Craig A. Otto**  
ARCHITECT, INC.

DESIGN • PLANNING • ARCHITECTURE

5044 Augusta Road  
Lexington, South Carolina 29072  
Phone (803) 957-9004  
Fax (803) 957-2050

No.	Revisions	Date

All rights reserved. This drawing and the design shown thereon are copyrighted as prescribed by the laws of the United States and are the sole property of Craig A. Otto, Architect, Inc. Anyone duplicating, reproducing, or causing to be reproduced these drawings or the design thereon without permission of the architect will be subject to legal action.

Project Title **DOLLAR GENERAL #23725**  
US 421 S, LILLINGTON, NC

Drawing Title **ADDITIONAL SECTIONS AND DETAILS**

Consultant

Seal 	Date JULY 8, 2021
	Drawn By OTTO
	Drawing No. <b>A3.1</b>

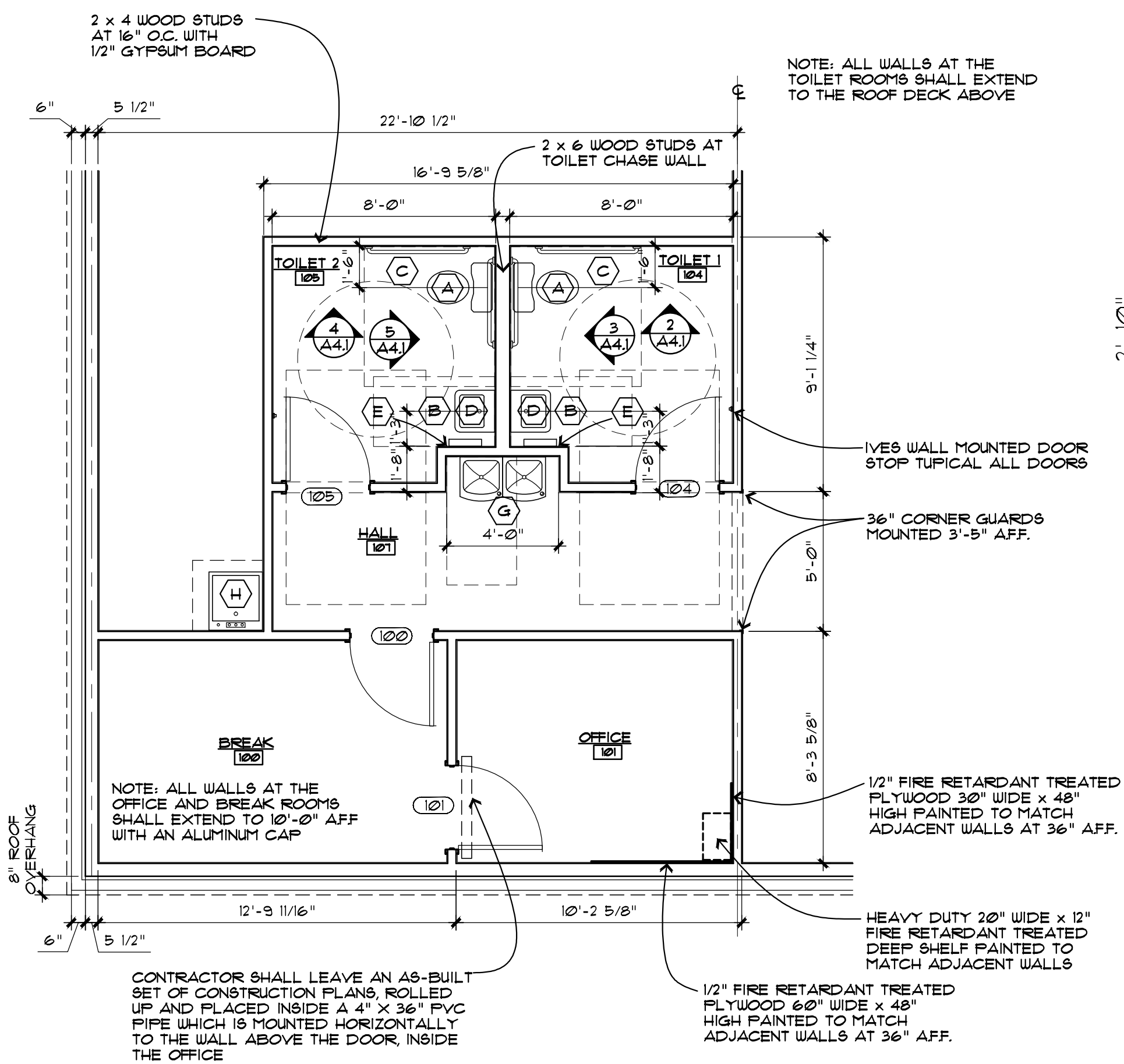

1 ENLARGED TOILET / OFFICE AREA PLAN  
SCALE: 1/4" = 1'-0"

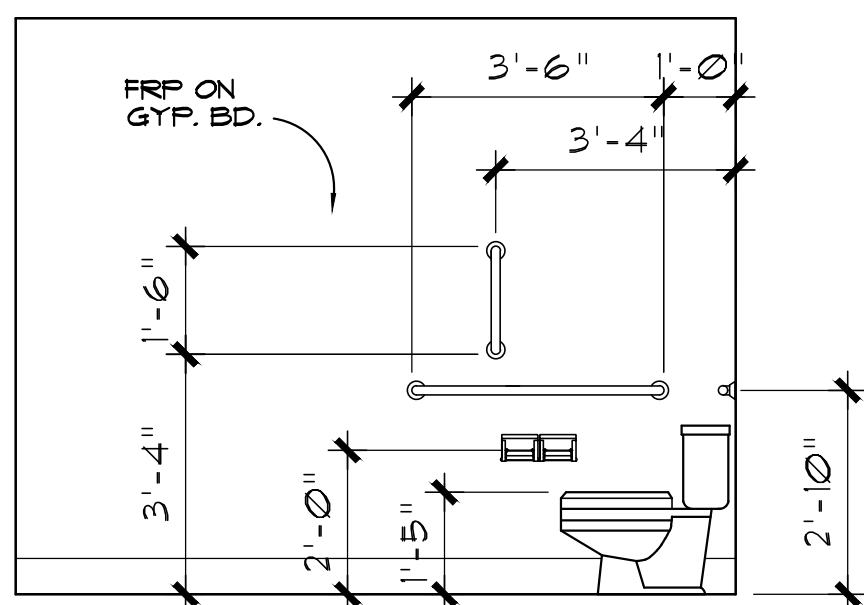

2 INTERIOR ELEVATION  
SCALE: 3/8" = 1'-0" (TOILET 1)

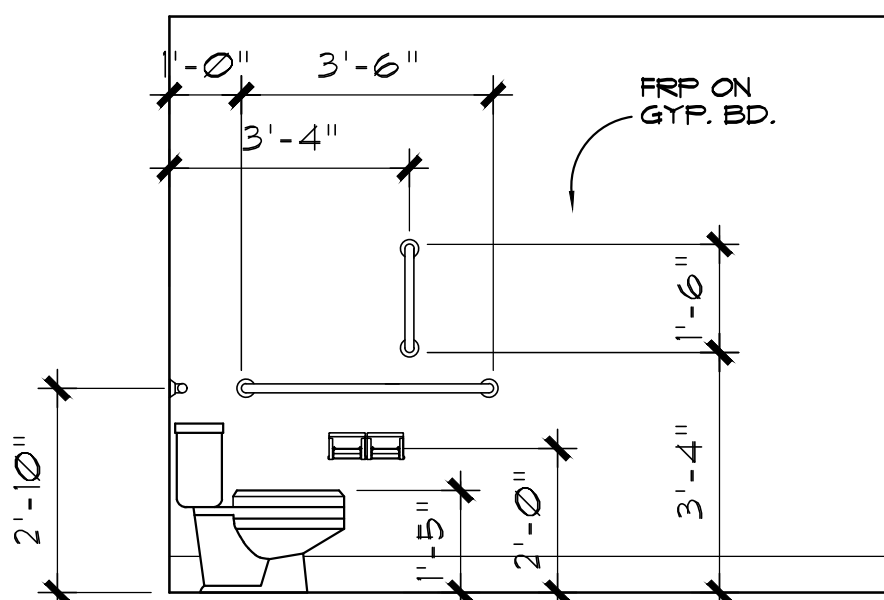

3 INTERIOR ELEVATION  
SCALE: 3/8" = 1'-0" (TOILET 1)

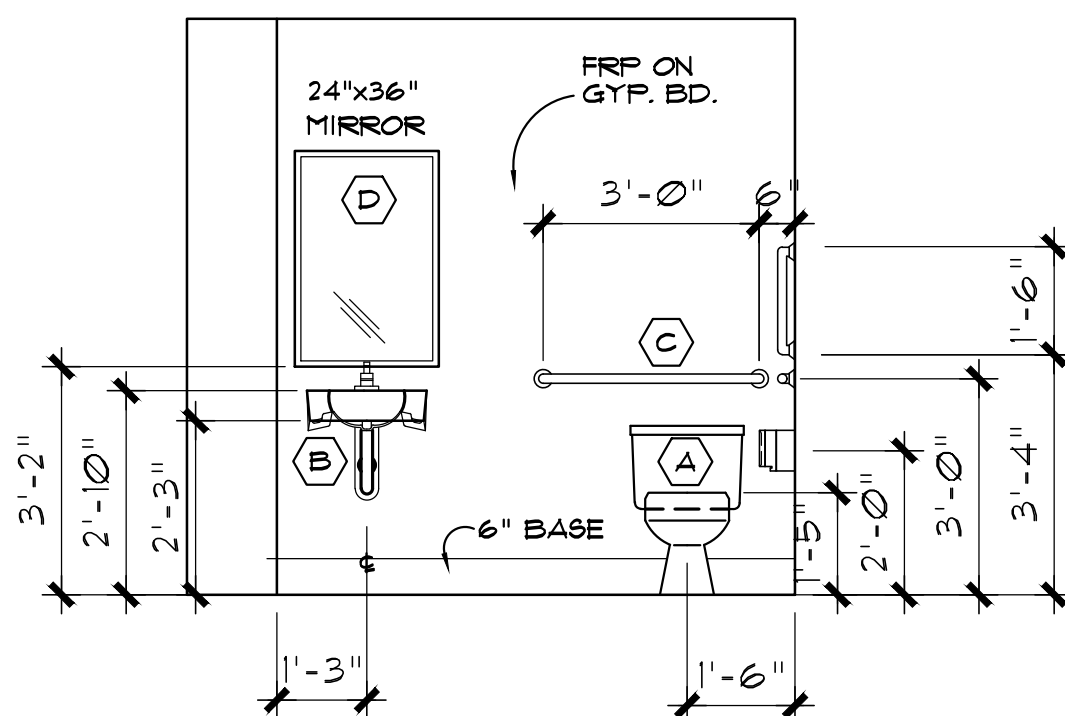

4 INTERIOR ELEVATION  
SCALE: 3/8" = 1'-0" (TOILET 2)

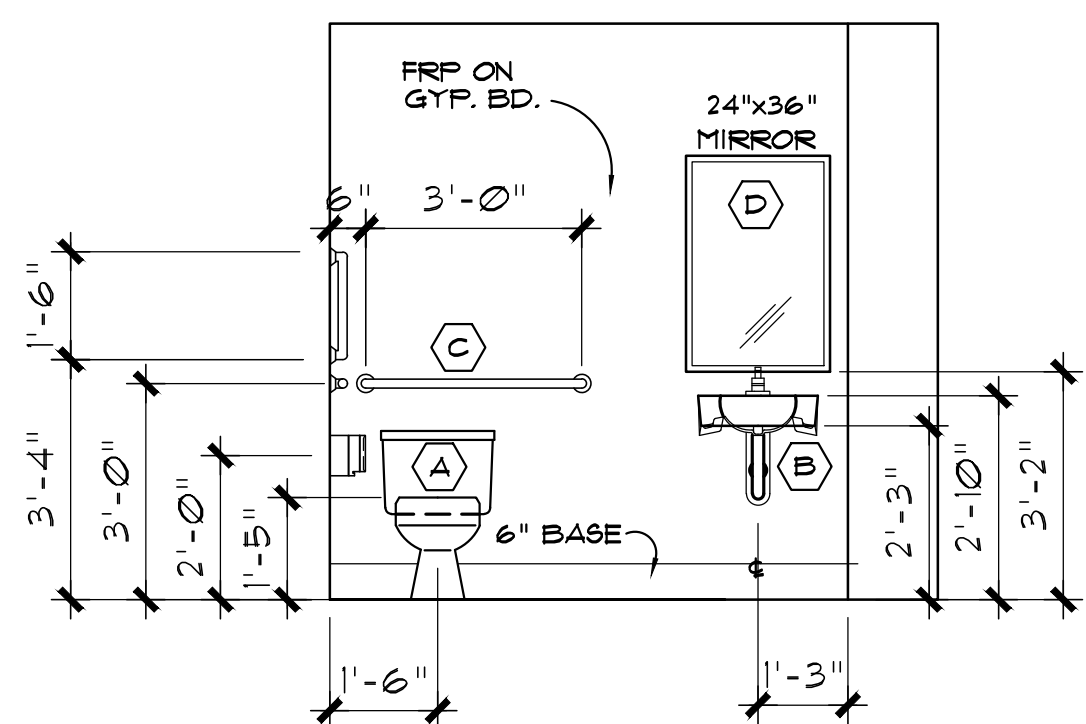

5 INTERIOR ELEVATION  
SCALE: 3/8" = 1'-0" (TOILET 2)

NOTE: MOUNTING HEIGHTS SHALL MEET ALL ADA REQUIREMENTS. SEE LEGEND FOR ACCESSORIES THAT APPLY TO THIS PROJECT

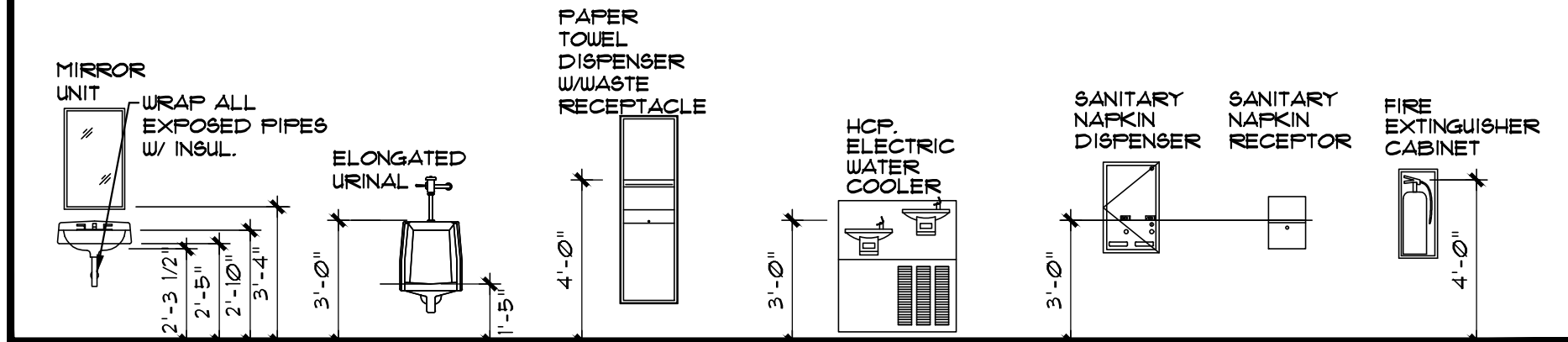

GENERAL CONTRACTOR SHALL PROVIDE AND INSTALL TOILET PAPER HOLDERS, PAPER TOWEL HOLDERS, DOOR CLOSERS, DOOR HOLDERS, EXHAUST FANS, AND ALL BASS SECURITY PARTS IN BOTH RESTROOMS. GENERAL CONTRACTOR SHALL PROVIDE NECESSARY BLOCKING IN THE WALL FOR THE INSTALLATION OF ALL ACCESSORIES. GENERAL CONTRACTOR SHALL PROVIDE ALL ACCESSORIES REQUIRED BY DOLLAR GENERAL.

- TOILET ROOM ACCESSORIES:
- B2140 BOBRICK DOUBLE TOILET TISSUE DISPENSER
  - B253 BOBRICK PAPER TOWEL DISPENSER
  - A-24x36 GAMCO 24" x 36" ANGLES FRAME MIRROR
  - 1505x36 GAMCO 1 1/2" x 36" GRAB BAR
  - 1505x42 GAMCO 1 1/2" x 42" GRAB BAR
  - 1505x18 GAMCO 1 1/2" x 18" GRAB BAR
  - M5-1 GAMCO MOP HOLDER



CHARACTER HEIGHT SHALL BE A MINIMUM OF 3" PER CODE  
GRADE 2 BRAILLE WITH DOTS 1/10" ON CENTER AND 2/10" SPACE BETWEEN CELLS RAISED 1/40" PER CODE

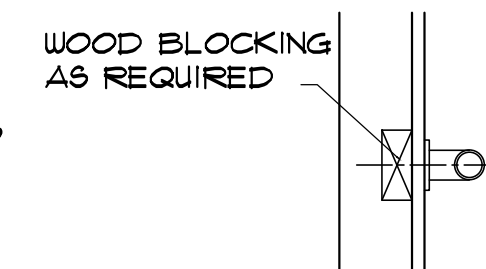

GRAB BAR SUPPORT BAR FASTENER & MOUNTING SUPPORT SHALL BE ABLE TO WITHSTAND 250 LBS. IN BENDING, SHEAR & TENSION.

SEE ELEVATIONS FOR MOUNTING HEIGHTS

- NOTES:
- SIGNS SHALL CONFORM TO ANSI OR LOCAL ACCESSIBILITY GUIDELINES WHICHEVER IS MORE STRINGENT.
  - ALL BUILDINGS AND ENTRANCES THAT ARE ACCESSIBLE AND USABLE BY PERSONS WITH DISABILITIES SHALL BE IDENTIFIED WITH A MINIMUM OF ONE INTERNATIONAL SYMBOL OF ACCESSIBILITY.
  - G.C. TO PROVIDE TACTILE "EXIT" SIGNS AT ALL GRADE LEVEL EXIT DOORS PER CODE.
  - SIGNS TO BE INSTALLED ON THE LATCH SIDE OF THE DOOR, OR IF NO SPACE ON THE NEAREST WALL PREFERABLY ON THE RIGHT. SIGNAGE SHALL HAVE NON GLARE FINISH W/ A CONTRASTING BACKGROUND. SEE A1 FOR LOCATION OF SIGNAGE.

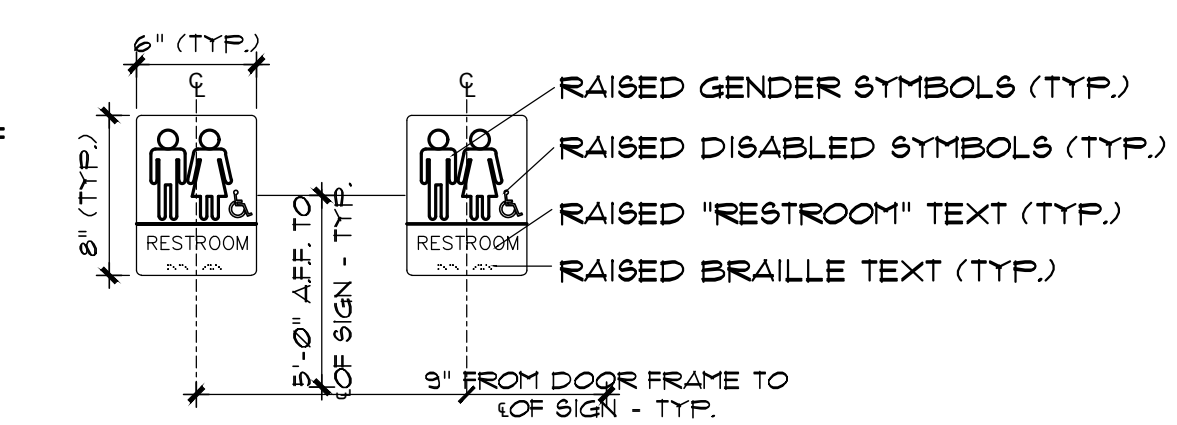

ACCESSORIES / FIXTURES LEGEND

- (A) BARRIER-FREE FLOOR MOUNTED TANK TYPE WATER CLOSET. THE WATER CLOSET SHALL BE POSITIONED WITH A WALL TO THE REAR AND TO ONE SIDE. THE CENTERLINE OF THE WATER CLOSET SHALL BE 16 INCHES MINIMUM TO 18 INCHES MAXIMUM FROM THE SIDE WALL. CLEARANCE AROUND THE WATER CLOSET SHALL BE 60 INCHES MINIMUM, MEASURED PERPENDICULAR FROM THE SIDE WALL, AND 56 INCHES MINIMUM, MEASURED PERPENDICULAR FROM THE REAR WALL. NO OTHER FIXTURES OR OBSTRUCTIONS SHALL BE WITHIN THE WATER CLOSET CLEARANCE. THE TOP OF THE WATER CLOSET SEAT SHALL BE 17 INCHES MINIMUM AND 19 INCHES MAXIMUM ABOVE THE FLOOR. SEATS SHALL NOT RETURN AUTOMATICALLY TO A LIFTED POSITION. PROVIDE DUAL ROLL TISSUE DISPENSER MOUNTED AT 24" ABOVE FINISHED FLOOR ON ADJACENT WALL.
- (B) VITREOUS CHINA WALL MOUNTED LAVATORY WITH BARRIER FREE "WRIST-BLADE" TYPE FAUCET. WRAP ALL PIPES UNDER SINK WITH INSULATION. TOP OF LAVATORY SHALL BE SET 2'-10" MAXIMUM ABOVE THE FLOOR AND PROVIDE 2'-5" CLEARANCE UNDER THE SINK. SINK SHALL BE 6 1/2 INCHES DEEP MAXIMUM.
- (C) GRAB BARS SHALL HAVE A CIRCULAR CROSS SECTION WITH A DIAMETER OF 1 1/4 INCH MINIMUM AND 2 INCHES MAXIMUM. THE SPACE BETWEEN THE WALL AND THE GRAB BAR SHALL BE 1 1/2 INCHES. THE SPACE BETWEEN THE GRAB BAR AND OBJECTS BELOW AND AT THE ENDS SHALL BE 1 1/2 INCHES MINIMUM. THE SPACE BETWEEN THE GRAB BAR AND PROJECTING OBJECTS ABOVE SHALL BE 15 INCHES MINIMUM AND 36 MAXIMUM ABOVE THE FLOOR.  
  
THE HORIZONTAL SIDE WALL GRAB BAR SHALL BE 42 INCHES LONG MINIMUM, LOCATED 12 INCHES MAXIMUM FROM THE REAR WALL AND EXTENDING 54 INCHES MINIMUM FROM THE REAR WALL.  
  
THE VERTICAL SIDE WALL GRAB BAR SHALL BE 18 INCHES LONG MINIMUM, AND SHALL BE MOUNTED WITH THE BOTTOM OF THE BAR BETWEEN 39 INCHES AND 41 INCHES ABOVE THE FLOOR, WITH THE CENTER LINE OF THE BAR LOCATED BETWEEN 39 INCHES AND 41 INCHES FROM THE REAR WALL.
- (D) MIRROR 24 INCHES WIDE BY 36 INCHES TALL CLIP MOUNTED AT TOP OF SPLASH. DO NOT GLUE MIRROR TO WALL.
- (E) SURFACE MOUNTED PAPER TOWEL HOLDER. MOUNT SUCH THAT PAPER TOWEL DELIVERY POINT IS 48 INCHES MAXIMUM ABOVE FINISHED FLOOR.
- (F) NOT USED
- (G) DUAL BARRIER-FREE ELECTRIC WATER COOLER (MOUNTED HIGH / LOW) INSTALLED SUCH THAT AT LEAST ONE SPOUT SHALL BE MOUNTED 36 INCHES ABOVE FINISHED FLOOR.
- (H) MOP SINK - SEE PLUMBING DRAWINGS

PROVIDE SOLID WOOD BLOCKING FOR ALL FIXTURES AND ACCESSORIES AS REQUIRED !!!

MOUNTING HEIGHTS ( ABOVE FINISHED FLOOR )

TOILET TISSUE DISPENSER :	24" TO CENTER
PAPER TOWEL DISPENSER / RECEPTACLE :	48" MAXIMUM TO PAPER DISPENSER
MIRROR :	36" MAXIMUM TO BOTTOM
GRAB BARS :	34" TO CENTER
LAVATORY :	29" MIN TO BOTTOM / 34" MAX TO RIM
BARRIER-FREE WATER CLOSET :	17" MINIMUM / 19" MAXIMUM TO RIM
URINAL :	17" TO RIM
FIRE EXTINGUISHER CABINET :	48" MAXIMUM TO TOP OF EXTINGUISHER

JOHN P. WATKINS, ARCHITECT  
56 HILLMARK DRIVE  
COLUMBIA, SOUTH CAROLINA 29210

**Craig A. Otto**  
ARCHITECT, INC.

DESIGN • PLANNING • ARCHITECTURE

5044 Augusta Road  
Lexington, South Carolina 29072  
Phone (803) 957-9004  
Fax (803) 957-2050

No.	Revisions	Date

All rights reserved. This drawing and the design shown thereon are copyrighted as prescribed by the laws of the United States and are the sole property of Craig A. Otto, Architect, Inc. Anyone duplicating, reproducing, or causing to be reproduced these drawings or the design thereon without permission of the architect will be subject to legal action.

Project Title **DOLLAR GENERAL #23725**  
US 421 S, LILLINGTON, NC

Drawing Title  
**ENLARGED FLOOR PLAN AND DETAILS**

Consultant

Seal



Date  
DECEMBER 8, 2021

Drawn By  
OTTO

Drawing No.

**A4.1**

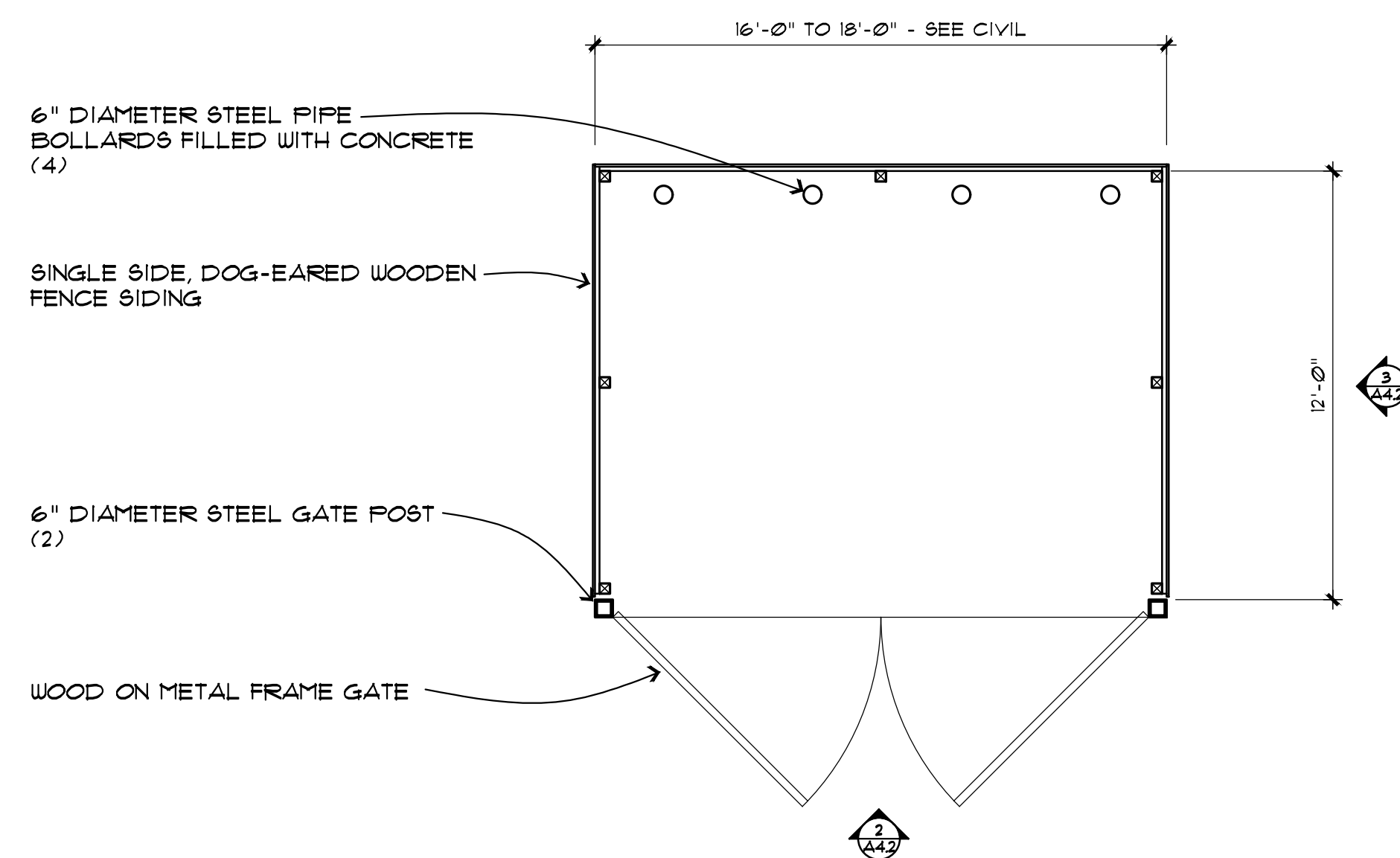

6" DIAMETER STEEL PIPE BOLLARDS FILLED WITH CONCRETE (4)

SINGLE SIDE, DOG-EARED WOODEN FENCE SIDING

6" DIAMETER STEEL GATE POST (2)

WOOD ON METAL FRAME GATE

**1 ENCLOSED DUMPSTER PLAN**  
SCALE: 1/4" = 1' - 0"  
CONFIRM WITH CIVIL DRAWINGS

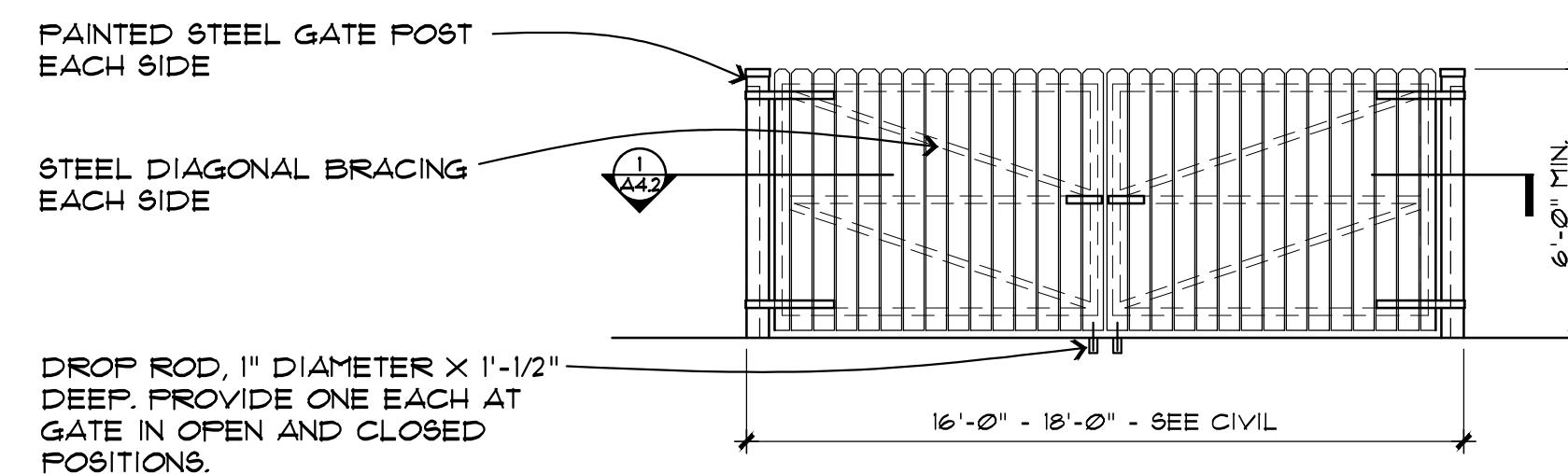

PAINTED STEEL GATE POST EACH SIDE

STEEL DIAGONAL BRACING EACH SIDE

DROP ROD, 1" DIAMETER X 1'-1/2" DEEP. PROVIDE ONE EACH AT GATE IN OPEN AND CLOSED POSITIONS.

**2 FRONT ELEVATION**  
SCALE: 1/4" = 1' - 0"  
CONFIRM WITH CIVIL DRAWINGS

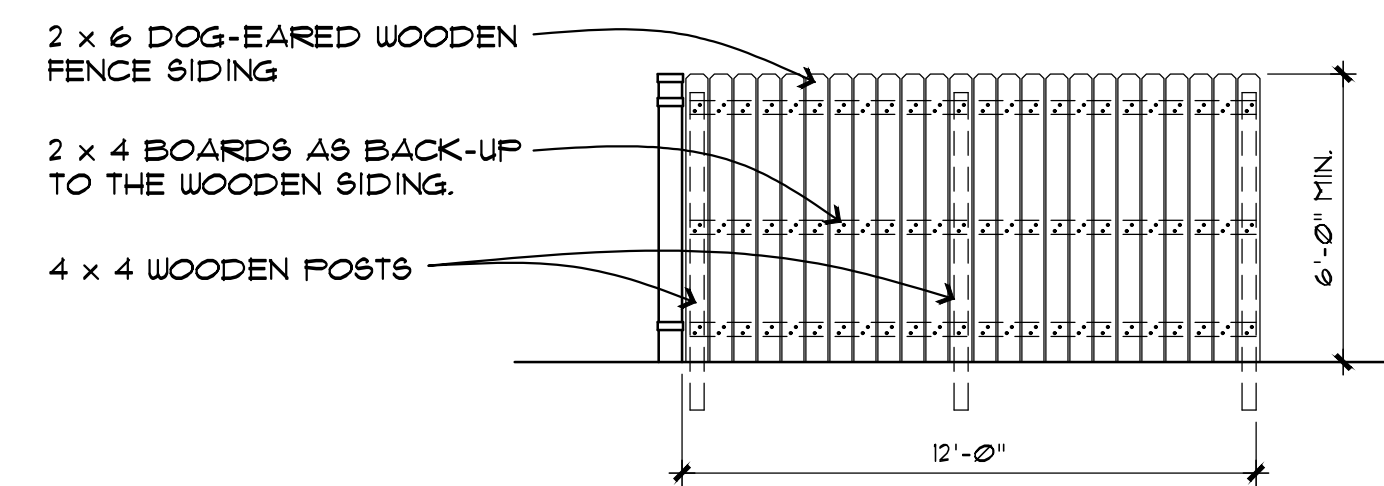

2 x 6 DOG-EARED WOODEN FENCE SIDING

2 x 4 BOARDS AS BACK-UP TO THE WOODEN SIDING.

4 x 4 WOODEN POSTS

**3 SIDE ELEVATION**  
SCALE: 1/4" = 1' - 0"  
REAR AND OPPOSITE SIDE ELEVATIONS ARE SIMILAR  
CONFIRM WITH CIVIL DRAWINGS

JOHN P. WATKINS, ARCHITECT  
56 HILLMARK DRIVE  
COLUMBIA, SOUTH CAROLINA 29210

**Craig A. Otto**  
ARCHITECT, INC.

DESIGN • PLANNING • ARCHITECTURE

5044 Augusta Road  
Lexington, South Carolina 29072  
Phone (803) 957-9004  
Fax (803) 957-2050

No.	Revisions	Date

All rights reserved. This drawing and the design shown thereon are copyrighted as prescribed by the laws of the United States and are the sole property of Craig A. Otto, Architect, Inc. Anyone duplicating, reproducing, or causing to be reproduced these drawings or the design thereon without permission of the architect will be subject to legal action.

Project Title **DOLLAR GENERAL #23725**  
US 421 S, LILLINGTON, NC

Drawing Title **DUMPSTER ENCLOSURE**  
PLAN AND DETAILS

Consultant

Seal 	Date DECEMBER 8, 2021
	Drawn By OTTO
	Drawing No. <b>A4.2</b>

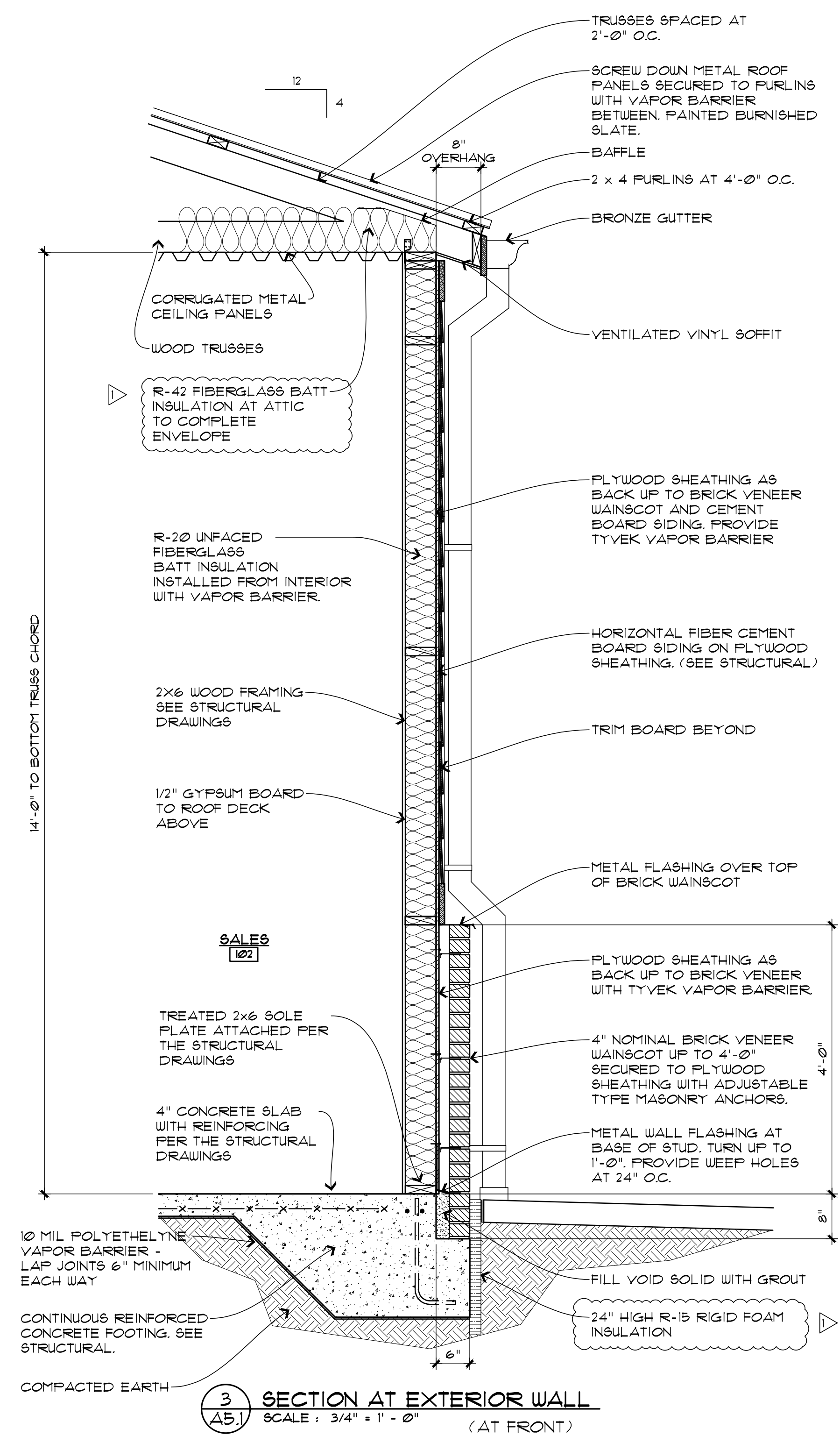
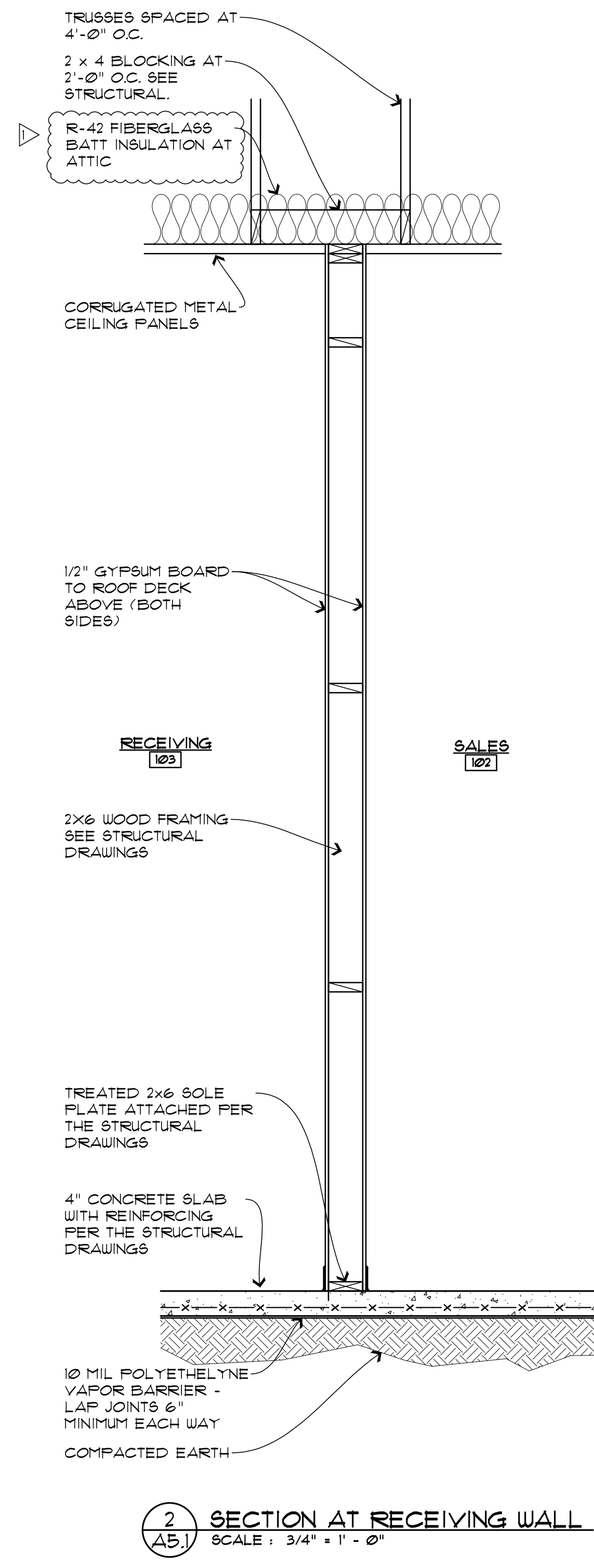
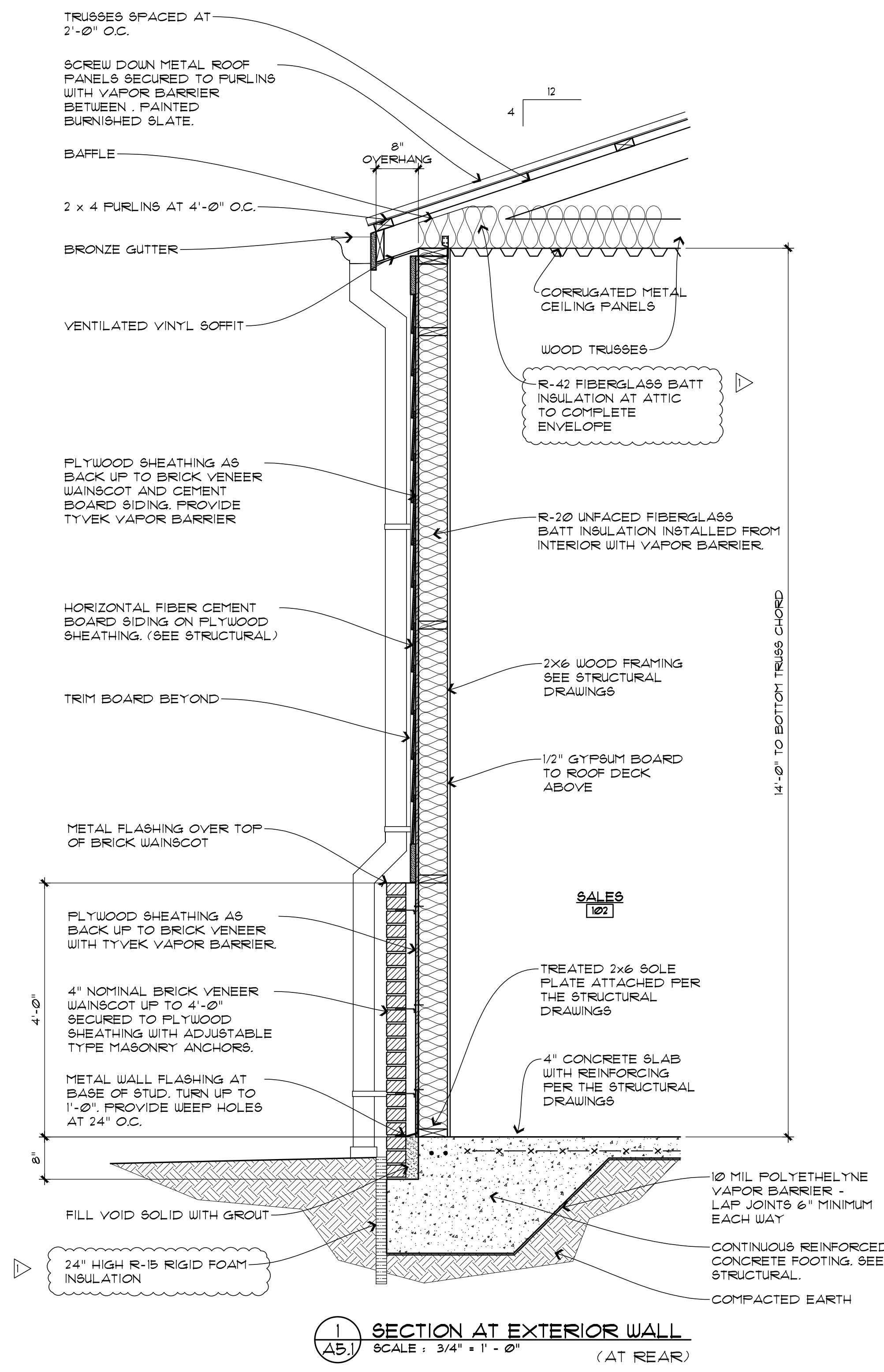

JOHN P. WATKINS, ARCHITECT  
56 HILLMARK DRIVE  
COLUMBIA, SOUTH CAROLINA 29210

**Craig A. Otto**  
ARCHITECT, INC.

DESIGN • PLANNING • ARCHITECTURE

5044 Augusta Road  
Lexington, South Carolina 29072  
Phone (803) 957-9004  
Fax (803) 957-2050

No.	Revisions	Date
1	UPDATED INSULATION SYSTEM	1/8/22

All rights reserved. This drawing and the design shown thereon are copyrighted as prescribed by the laws of the United States and are the sole property of Craig A. Otto, Architect, Inc. Anyone duplicating, reproducing, or causing to be reproduced these drawings or the design thereon without permission of the architect will be subject to legal action.

Project Title **DOLLAR GENERAL #23725**  
US 421 S, LILLINGTON, NC

Drawing Title **WALL SECTIONS**

Consultant

Seal

Date **DECEMBER 8, 2021**  
Drawn By **OTTO**  
Drawing No. **A5.1**

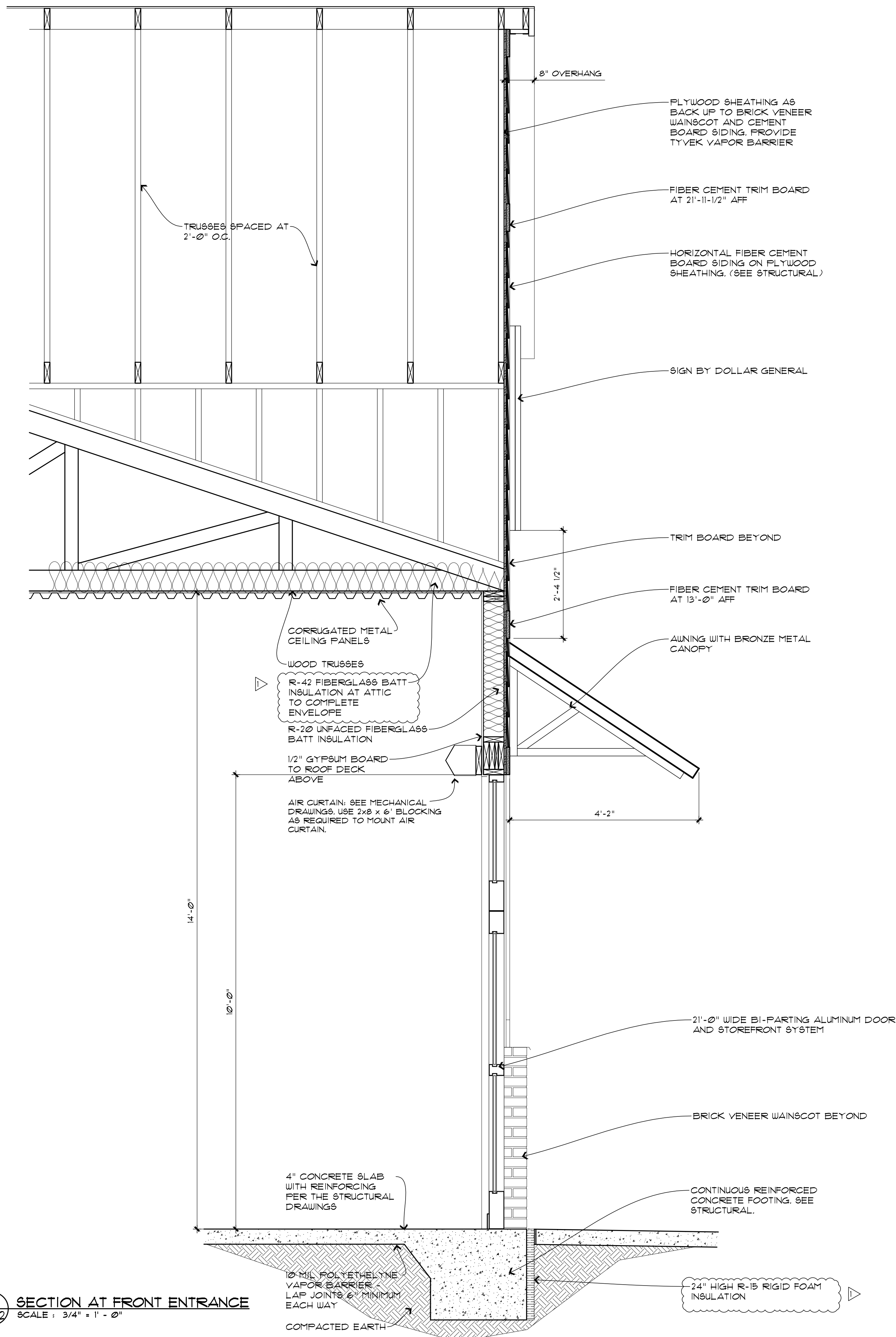

1 SECTION AT FRONT ENTRANCE  
SCALE: 3/4" = 1' - 0"

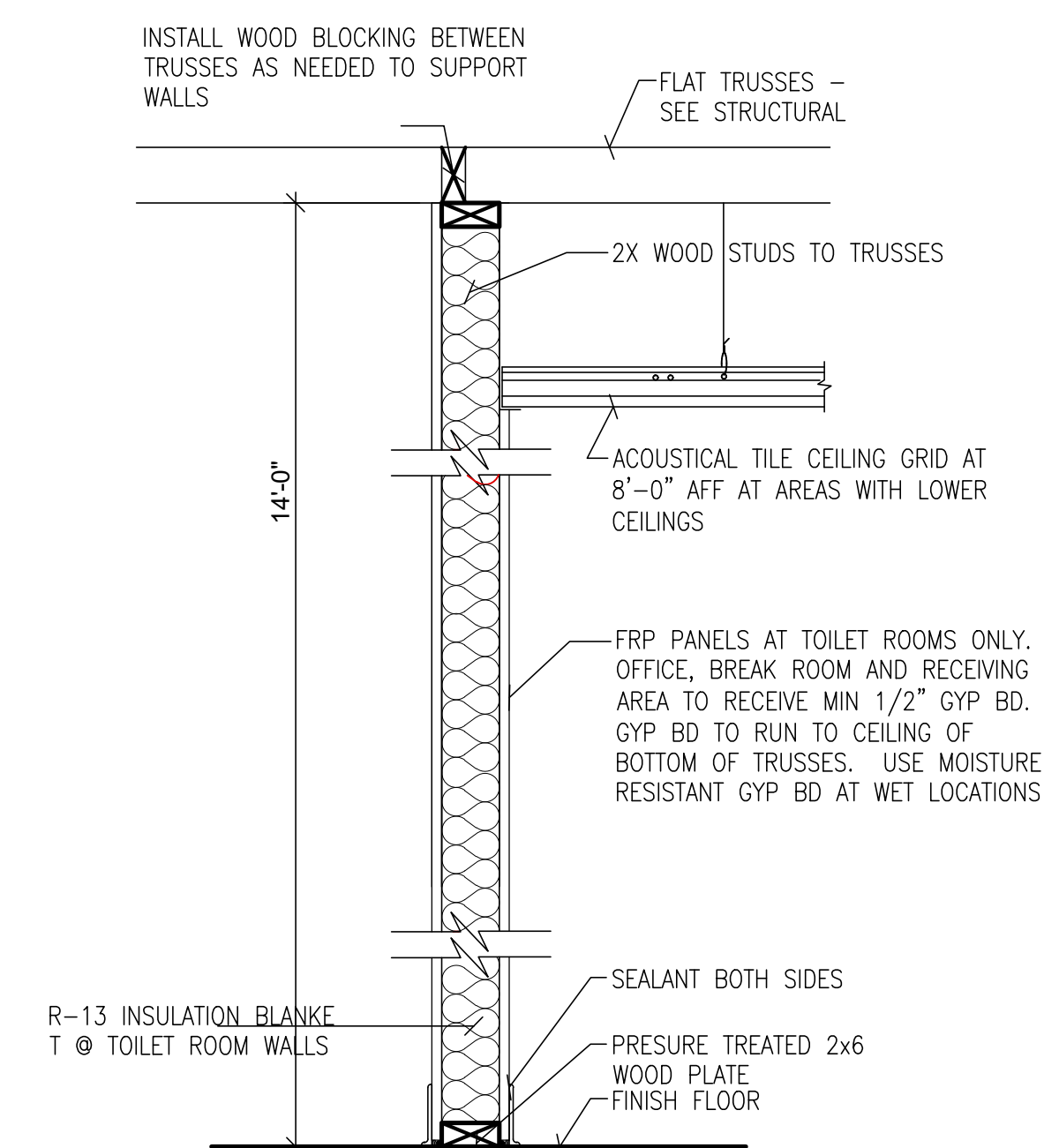

2 SECTION AT INTERIOR LOW CEILINGS  
SCALE: NONE

JOHN P. WATKINS, ARCHITECT  
56 HILLMARK DRIVE  
COLUMBIA, SOUTH CAROLINA 29210

**Craig A. Otto**  
ARCHITECT, INC.

DESIGN • PLANNING • ARCHITECTURE

5044 Augusta Road  
Lexington, South Carolina 29072  
Phone (803) 957-9004  
Fax (803) 957-2050

No.	Revisions	Date
1	UPDATED INSULATION SYSTEM	1/8/22

All rights reserved. This drawing and the design shown thereon are copyrighted as prescribed by the laws of the United States and are the sole property of Craig A. Otto, Architect, Inc. Anyone duplicating, reproducing, or causing to be reproduced these drawings or the design thereon without permission of the architect will be subject to legal action.

Project Title **DOLLAR GENERAL #23725**  
US 421 S, LILLINGTON, NC

Drawing Title  
**WALL SECTIONS**

Consultant

	Date DECEMBER 8, 2021
	Drawn By OTTO
	Drawing No. <b>A5.2</b>

DOOR SCHEDULE

NO.	TYPE	DOOR			DOOR HARDWARE	REMARKS
		WIDTH	HEIGHT	THICKNESS		
100	A	3' - 0"	7' - 0"	0' - 1 3/4"	(1) FALCON PASSAGE LEVERSET NO. W018-DANE-626. NO KEY REQUIRED. (1) HAGER DOOR CLOSER NO. 5400. (1) IVES WALL STOP NO. 402-1/2B-26D.	SOLID CORE WOOD DOOR. PAINT FRAME AND BOTH SIDES OF DOOR SHERWIN WILLIAMS SW 6991 BLACK MAGIC SEMI-GLOSS.
101	B	3' - 0"	7' - 0"	0' - 1 3/4"	(1) FALCON STOREROOM LEVERSET NO. W501PD-DANE-626, KEY NO. 1. (1) HAGER DOOR CLOSER NO. 5400. (1) IVES WALL STOP NO. 402-1/2B-26D. (1) TACO DOOR VIEWER NO. T43310FC.	SOLID CORE WOOD DOOR. PAINT FRAME AND BOTH SIDES OF DOOR SHERWIN WILLIAMS SW 6991 BLACK MAGIC SEMI-GLOSS.
102	D	3' - 0"	7' - 0"	0' - 1 3/4"	(1) VON DUPRIN GUARD-X EXIT ALARM LOCK NO. 2670-28. (1) HAGER DOOR CLOSER NO. 5400. (1) DOOR SWEEP NO. T105AV-3FT, WEATHERSTRIPPING NO. 0928AV-84INCH. (1) RIM CYLINDER NO. T015C08-26D. HAGER BN FULL.	R-10 INSULATED CORE METAL DOOR. PAINT INTERIOR OF DOOR AND FRAME SHERWIN WILLIAMS SW 6991 BLACK MAGIC SEMI-GLOSS. PAINT EXTERIOR OF DOOR AND FRAME SHERWIN WILLIAMS SW 1041 VAN DYKE BROWN SEMI-GLOSS.
103A	C	6' - 0"	8' - 0"	0' - 1 3/4"	(2) BURNS PULL PLATES NO. 5410-32D-26D-GRIP. (2) BURNS PUSH PLATES NO. 54-U832D. (4) IVES KICK PLATES NO. 8400-832D-8x34. (2) HAGER DOOR CLOSERS NO. 5400. (2) IVES 4" DOOR HOLDER NO. 452B26D-4. (1) IVES WALL STOP NO. 402-1/2B-26D.	SOLID CORE WOOD OR HOLLOW METAL DOOR. PAINT FRAME AND BOTH SIDES OF DOOR SHERWIN WILLIAMS SW 6991 BLACK MAGIC SEMI-GLOSS.
103B	E	6' - 0"	8' - 0"	0' - 1 3/4"	(1) VON DUPRIN GUARD-X EXIT ALARM LOCK NO. 2670-28. (1) VON DUPRIN GUARD-X DOUBLE DOOR STRIKE NO. 2609. (1) DETEX DOUBLE DOOR HOLDER NO. DDH-2250 TOP AND BOTTOM. (2) HAGER DOOR CLOSERS NO. 5400. (2) BURNS PULL PLATES NO. 5410-32D-26D-GRIP. (2) BURNS PUSH PLATES NO. 54-U832D. (1) 2" DOOR SCOPE NO. D6/1000MB. (2) 8" DOOR HOLDERS NO. 608Z. (1) NATIONAL GUARD HD THRESHOLD NO. 425 HD-6FT. (2) DOOR SWEEPS NO. T105AV-3FT, WEATHERSTRIPPING HAGER NO. 0928AV. (1) RIM CYLINDER NO. T015C08-26D.	R-10 INSULATED CORE METAL DOOR. PAINT INTERIOR OF DOOR AND FRAME SHERWIN WILLIAMS SW 6991 BLACK MAGIC SEMI-GLOSS. PAINT EXTERIOR OF DOOR AND FRAME SHERWIN WILLIAMS SW 1041 VAN DYKE BROWN SEMI-GLOSS.
104	A	3' - 0"	7' - 0"	0' - 1 3/4"	(1) FALCON STOREROOM LEVERSET W501PD-DANE-626-KEY NO. 2. (1) HAGER DOOR CLOSER NO. 5400. (1) IVES WALL STOP NO. 402-1/2B-26D. (1) IVES 4" DOOR HOLDER NO. 452B26D-4.	SOLID CORE WOOD DOOR. PAINT FRAME AND BOTH SIDES OF DOOR SHERWIN WILLIAMS SW 6991 BLACK MAGIC SEMI-GLOSS.
105	A	3' - 0"	7' - 0"	0' - 1 3/4"	(1) FALCON STOREROOM LEVERSET W501PD-DANE-626-KEY NO. 2. (1) HAGER DOOR CLOSER NO. 5400. (1) IVES WALL STOP NO. 402-1/2B-26D. (1) IVES 4" DOOR HOLDER NO. 452B26D-4.	SOLID CORE WOOD DOOR. PAINT FRAME AND BOTH SIDES OF DOOR SHERWIN WILLIAMS SW 6991 BLACK MAGIC SEMI-GLOSS.
106	F	6' - 0"	7' - 0"	(SEE MFR.)	BY DOOR MANUFACTURER TO BE RE-KEYED BY DOLLAR GENERAL AREA MANAGER WITH (1) ILCO RIM CYLINDER NO. T015C08-26D.	21"-0" WIDE BI-PART DOOR SYSTEM WITH TRANSOM AND INSULATED GLAZING (TEMPERED WHERE REQUIRED), BRONZE FINISH.

REQUIRED INTERIOR DOORS AND DOOR FRAMES: CONTACT GIRTMAN AND ASSOCIATES, NASHVILLE, TN PHONE: 615-350-6000 FAX: 615-350-6686 (EXTERIOR DOORS AND DOOR FRAMES ARE OPTIONAL)

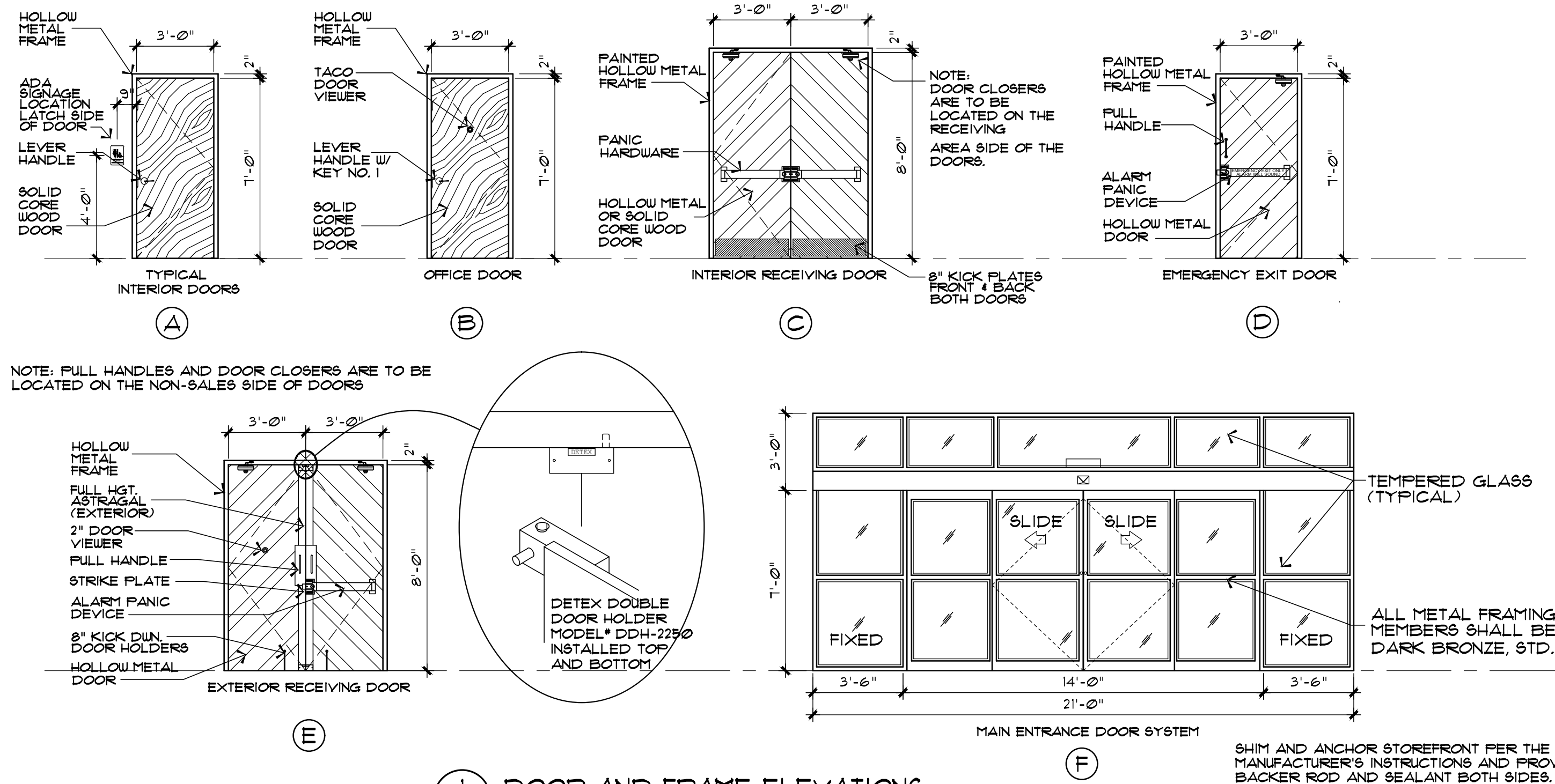

1 DOOR AND FRAME ELEVATIONS  
SCALE: 1/4" = 1' - 0"

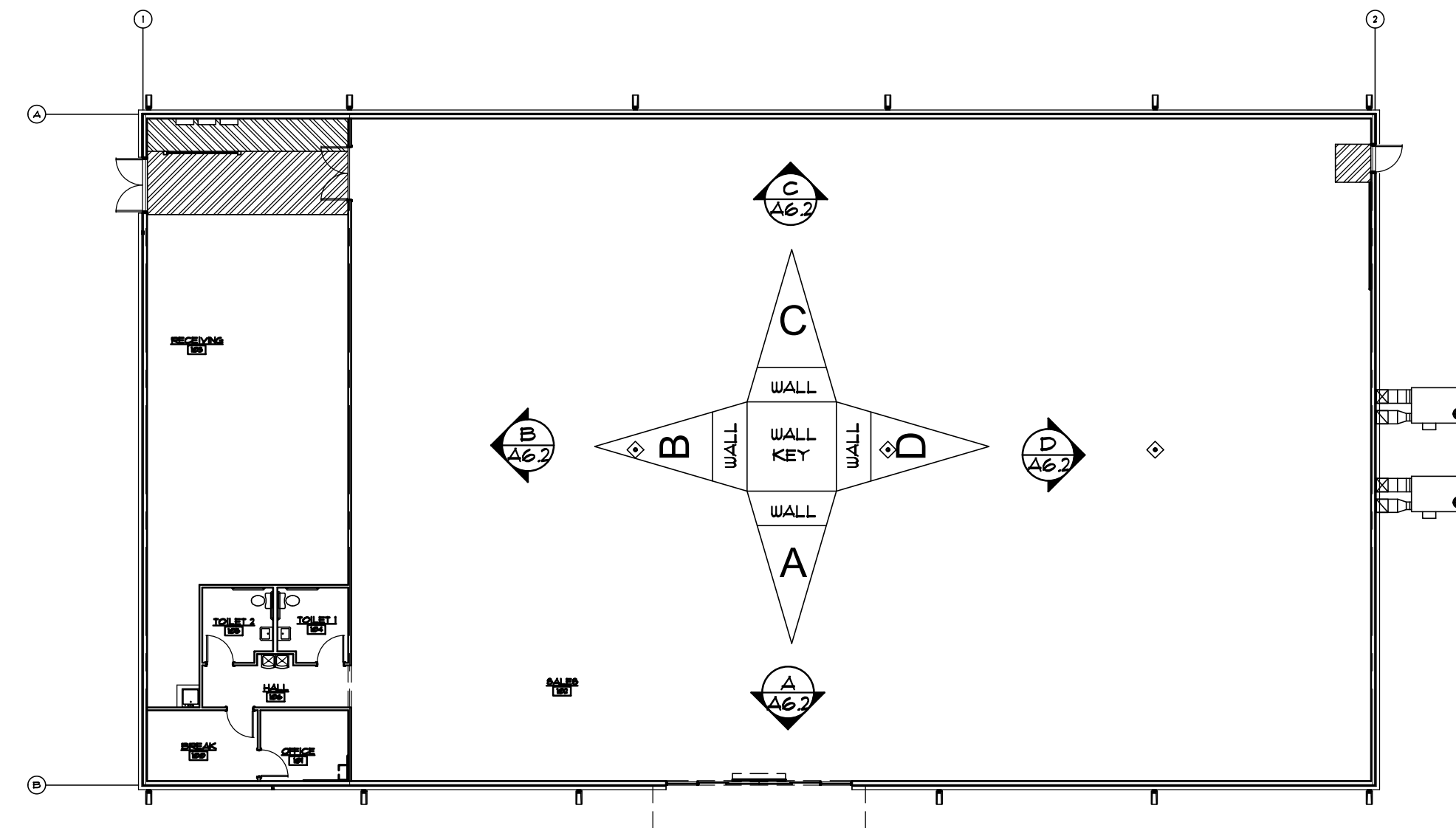

ROOM FINISH SCHEDULE

NO.	ROOM NAME	FLOOR		BASE		A WALL		B WALL		C WALL		D WALL		CEILING MATERIAL	CEILING FINISH	REMARKS
		MATERIAL	FINISH	MATERIAL	FINISH	MATERIAL	FINISH	MATERIAL	FINISH	MATERIAL	FINISH	MATERIAL	FINISH			
100	BREAK ROOM	CONCRETE FLOOR SEALED	CONCRETE WITH SEALER	4" RUBBER/VINYL BASE	BLACK	GYP SUM BOARD TO CEILING	SHERWIN WILLIAMS SW1005 PURE WHITE PRO-MAR LATEX SEMI-GLOSS	GYP SUM BOARD TO CEILING	SHERWIN WILLIAMS SW1005 PURE WHITE PRO-MAR LATEX SEMI-GLOSS	GYP SUM BOARD TO 10'-0" AFF.	SHERWIN WILLIAMS SW1005 PURE WHITE PRO-MAR LATEX SEMI-GLOSS	GYP SUM BOARD TO 10'-0" AFF.	SHERWIN WILLIAMS SW1005 PURE WHITE PRO-MAR LATEX SEMI-GLOSS	CORRUGATED METAL CEILING	N/A	
101	OFFICE	CONCRETE FLOOR SEALED	CONCRETE WITH SEALER	4" RUBBER/VINYL BASE	BLACK	GYP SUM BOARD TO CEILING	SHERWIN WILLIAMS SW1005 PURE WHITE PRO-MAR LATEX SEMI-GLOSS	GYP SUM BOARD TO 10'-0" AFF.	SHERWIN WILLIAMS SW1005 PURE WHITE PRO-MAR LATEX SEMI-GLOSS	GYP SUM BOARD TO 10'-0" AFF.	SHERWIN WILLIAMS SW1005 PURE WHITE PRO-MAR LATEX SEMI-GLOSS	GYP SUM BOARD TO 10'-0" AFF.	SHERWIN WILLIAMS SW1005 PURE WHITE PRO-MAR LATEX SEMI-GLOSS	CORRUGATED METAL CEILING	N/A	
102	SALES	CONCRETE FLOOR POLISHED	9 STEP FOLISH SYSTEM	4" RUBBER/VINYL BASE	BLACK									CORRUGATED METAL CEILING	N/A	SEE INTERIOR ELEVATIONS FOR PAINT SCHEME
103	RECEIVING	CONCRETE FLOOR SEALED	CONCRETE WITH SEALER	N/A	N/A	GYP SUM BOARD TO CEILING	TAPED, MUDDED, AND PAINTED OR PROVIDE METAL LINER PANELS	GYP SUM BOARD TO CEILING	WHITE	GYP SUM BOARD TO CEILING	WHITE	GYP SUM BOARD TO CEILING	TAPED, MUDDED, AND PAINTED OR PROVIDE METAL LINER PANELS	CORRUGATED METAL CEILING	N/A	
104	TOILET 1	CONCRETE FLOOR SEALED	SHERWIN WILLIAMS HC-117 "SILK CHOCOLATE" ACRYLIC SILICONE	4" RUBBER/VINYL BASE	BLACK	GYP SUM BOARD TO 8'-0" AFF.	WHITE FIBERGLASS REINFORCED PANELS TO 8'-0" AFF.	GYP SUM BOARD TO 8'-0" AFF.	WHITE FIBERGLASS REINFORCED PANELS TO 8'-0" AFF.	GYP SUM BOARD TO 8'-0" AFF.	WHITE FIBERGLASS REINFORCED PANELS TO 8'-0" AFF.	GYP SUM BOARD TO 8'-0" AFF.	WHITE FIBERGLASS REINFORCED PANELS TO 8'-0" AFF.	S.A.T. CEILING AT 8'-0" AFF.	WHITE	
105	TOILET 2	CONCRETE FLOOR SEALED	SHERWIN WILLIAMS HC-117 "SILK CHOCOLATE" ACRYLIC SILICONE	4" RUBBER/VINYL BASE	BLACK	GYP SUM BOARD TO 8'-0" AFF.	WHITE FIBERGLASS REINFORCED PANELS TO 8'-0" AFF.	GYP SUM BOARD TO 8'-0" AFF.	WHITE FIBERGLASS REINFORCED PANELS TO 8'-0" AFF.	GYP SUM BOARD TO 8'-0" AFF.	WHITE FIBERGLASS REINFORCED PANELS TO 8'-0" AFF.	GYP SUM BOARD TO 8'-0" AFF.	WHITE FIBERGLASS REINFORCED PANELS TO 8'-0" AFF.	S.A.T. CEILING AT 8'-0" AFF.	WHITE	
106	NOT USED															
107	HALL	CONCRETE FLOOR POLISHED	9 STEP FOLISH SYSTEM	4" RUBBER/VINYL BASE	BLACK	GYP SUM BOARD TO 10'-0" AFF.	SHERWIN WILLIAMS PRO-MAR LATEX SEMI-GLOSS SEE ELEVATIONS SHEET A6.2	GYP SUM BOARD TO CEILING	SHERWIN WILLIAMS PRO-MAR LATEX SEMI-GLOSS SEE ELEVATIONS SHEET A6.2	GYP SUM BOARD TO CEILING	SHERWIN WILLIAMS PRO-MAR LATEX SEMI-GLOSS SEE ELEVATIONS SHEET A6.2	GYP SUM BOARD TO 10'-0" AFF. WITH BULKHEAD AT 7'-0" AFF.	N/A	CORRUGATED METAL CEILING	N/A	SEE INTERIOR ELEVATIONS FOR PAINT SCHEME

JOHN P. WATKINS, ARCHITECT  
56 HILLMARK DRIVE  
COLUMBIA, SOUTH CAROLINA 29210

**Craig A. Otto**  
ARCHITECT, INC.

DESIGN • PLANNING • ARCHITECTURE

5044 Augusta Road  
Lexington, South Carolina 29072  
Phone (803) 957-9004  
Fax (803) 957-2050

No.	Revisions	Date

All rights reserved. This drawing and the design shown thereon are copyrighted as prescribed by the laws of the United States and are the sole property of Craig A. Otto, Architect, Inc. Anyone duplicating, reproducing, or causing to be reproduced these drawings or the design thereon without permission of the architect will be subject to legal action.

Project Title **DOLLAR GENERAL #23725**  
US 421 S, LILLINGTON, NC

Drawing Title **DOOR AND FINISH SCHEDULES AND DETAILS**

Consultant

Seal  
*Craig A. Otto*  
3629  
SOUTH CAROLINA  
COLUMBIA, S.C.

Date **DECEMBER 8, 2021**  
Drawn By **OTTO**  
Drawing No. **A6.1**

REQUIRED NATIONAL ACCOUNT VENDORS				
	COMPANY	CONTACTS	PHONE #	REQUIRED ITEMS
CONCRETE SITE	RAINBIRD IRRIGATION	LOCAL RAIN BIRD DISTRIBUTER	WWW.RAINBIRD.COM	IRRIGATION SYSTEMS
	EUCALID CHEMICAL COMPANY	PHIL BRANDT	877-438-3826 PBrandt@eucalidchemical.com	CONCRETE POLISHING SYSTEMS
CONCRETE POLISHING	RETRO-PLATE SYSTEMS	SCOTT MAXFIELD	801-641-6796 scott.maxfield@retroplatesystem.com	CONCRETE POLISHING SYSTEMS
	RECORD DOOR SYSTEMS	MICHAEL VINNIK	704-290-0234 dollargeneral@recorddoors.com	IN, KY, MD, OH, PA, VA, WV MODEL #5100 SERIES
STOREFRONT ENTRANCE	STANLEY ACCESS TECHNOLOGIES	DENNIS WEBB	256-776-8902 DGdoors@sbinc.com	AR, AZ, CA, CO, CT, DE, IL, IA, KS, LA, MA, ME, MI, MN, MO, ND, NE, NH, NJ, NM, NV, NY, OK, OR, RI, SD, TX, VT, WI MODEL #DG2000
	ASSA ABLOY ENTRANCE SYSTEMS	ROSS MERKLING	609-528-2580 dollargeneral.besam.us@assaabloy.com	AL, FL, GA, MS, NC, SC, TN MODEL #SL500
INTERIOR DOORS	GIRTMAN AND ASSOCIATES	MIKE MOYNAHAN	615-350-6000 dgconstruction@bass-security.com	INTERIOR DOORS AND FRAMES AND RESTROOM ACCESSORIES AL, AR, AZ, CA, CO, FL, GA, IA, KS, LA, MS, MN, MO, NE, NM, NV, OK, OR, SC, SD, TN, TX, WI
	COOK & BOARDMAN GROUP	JOE HARRELL	336-837-0673 nationalsales@cookandboardman.com	INTERIOR DOORS AND FRAMES AND RESTROOM ACCESSORIES CT, DE, IL, IN, KY, MA, MD, ME, MI, NC, NH, NJ, NY, OH, PA, RI, VA, VT, WV
FINISHES	SHERWIN WILLIAMS	LOCAL SHERWIN WILLIAMS		PAINT, PRIMER, CONCRETE SEALER AND BLOCK FILLER
	MC CUE CORPORATION	REY O'NEILL	678-492-4026 koneill@mccue.com	TRIM KIT INCLUDES BUMPER GUARDS AND CART STOP
HVAC UNITS	YORK	NATIONAL ACCOUNTS	800-481-9738 york-dollargeneral-be@jci.com	HVAC UNITS AR, CO, IL, IN, KY, KS, MO, OH, OK, WV
	CARRIER	HASAN KHALIL	315-432-7655 Hasan.Khalil@carrier.utc.com	HVAC UNITS CT, IA, MA, ME, MI, MN, ND, NE, NH, NJ, NY, PA, RI, SD, VT, WI
	LENNOX	SCOTT MACDONALD	972-497-6781 dollargeneral@lennoxind.com	HVAC UNITS AL, AZ, CA, DE, FL, GA, LA, MD, MS, NC, NM, NV, OR, SC, TN, TX, VA
	ROOF CURB SYSTEMS	CLIFTON REASOR	800-683-5848 DollarGeneral@roofcurb.com	RTU CURB
RTU CURBS	CURBS PLUS INC.	ALLAN THRAIKILL	888-639-2872 alan.thraikill@curbs-plus.com	RTU CURB
	KCC INTERNATIONAL INC.	GREG CONRAD	800-382-2872 gconrad@kcccurbs.com	RTU CURB
ELECTRICAL SWITCH GEAR	CED - CONSOLIDATED ELECTRICAL DISTRIBUTORS	ROBERT DECKER	270-781-2229 robertd@cedbgky.com	ELECTRICAL SWITCH GEAR AR, AZ, CA, CO, IA, IN, IL, LA, KS, KY, MI, MN, MO, MS, ND, NE, NM, NV, OK, OR, SD, TX, WI
	NESCO	CHRIS TRACY	800-244-6980 dollargeneral@needhamelectric.com	ELECTRICAL SWITCH GEAR AL, CT, DE, FL, GA, MA, MD, ME, NC, NH, NJ, NY, OH, PA, RI, SC, TN, VA, VT, WV
LIGHTING	USLED	DANA PORTER PAUL JEZIOROWSKI	713-337-3836 DGUSLED@usled.com	ELECTRICAL LIGHTING SUPPLIES AR, CO, IA, IL, IN, KS, KY, MI, MN, MO, ND, NE, OH, OK, SD, WI, WV
	LEDS	MICHAEL STRINGER KYLE KNAPP	920-915-4010 DGORDER@leds-llc.com	ELECTRICAL LIGHTING SUPPLIES AL, AZ, CA, CT, DE, FL, GA, LA, MA, MD, ME, MS, NC, NH, NJ, NM, NV, NY, OR, PA, RI, SC, TN, TX, VA, VT
LOW VOLTAGE SYSTEM	D&P CUSTOM LIGHTING	NATIONAL ACCOUNT SALES	800-251-2200	CUSTOM POWER POLES
	CROSSCOM NATIONAL	ANDREA LEMAY	847-850-6297 dollargeneral@crosscomnational.com	LOW VOLTAGE & VOICE/DATA CO, DE, FL, IA, IL, IN, KS, MD, ME, MI, MN, MO, ND, NE, NH, NJ, NY, OH, RI, SD, VT, WI, WV, WY
	ASD	CHRIS RUDNITSKI	828-624-1046 crudnitski@asd-usa.com	LOW VOLTAGE & VOICE/DATA AL, AR, AZ, CA, CT, GA, KY, LA, MA, MS, NC, NM, NV, OK, OR, PA, RI, SC, TN, TX, VA, WA
	GRAYBAR	JEROME BANNISTER	615-743-3202 office, 615-924-2135 cell DollarGeneral@graybar.com	CABLE TRAY
ELECTRICAL	EMERSON CLIMATE TECHNOLOGIES	WEBSITE: http://dollargeneralbid.ectsolutions.net	USER NAME: dollargeneralbid PASSWORD: dollargeneralbid	EMS SUPPLIER NOTE: CUSTOMIZED DOLLAR GENERAL EMS PANEL REQUIRES STORE #, CITY, STATE, ZIP CODE & QTY. OF HVAC UNITS OF THE INSTALL SITE WHEN ORDERING.
	STANLEY CONVERGENT SECURITY SOLUTIONS	DAN GOLDSMITH	740-215-8913	INTERIOR FIRE ALARM PANELS

VERIFY EXTENTS OF FINISHED WALLS WITH FINAL FIXTURE PLAN. ONCE FIXTURES ARE INSTALLED, THERE SHOULD BE NO VISIBLE UNFINISHED WALLS.

WALL PAINT LEGEND			
	P1 SW1065 "ARGOS"		P4 SW6910 "DAISY"
	P2 SW6991 "BLACK MAGIC"		P5 PREFINISHED WHITE METAL LINER PANELS (EXPOSED)
	P3 SW1005 "PURE WHITE"		P6 DENOTES TAPED AND MUDDING ONLY

PAINT EXPOSED CEILING STRUCTURE AND ALL BUILDING ELEMENTS INCLUDING CONDUITS, ETC. SW1005 PURE WHITE

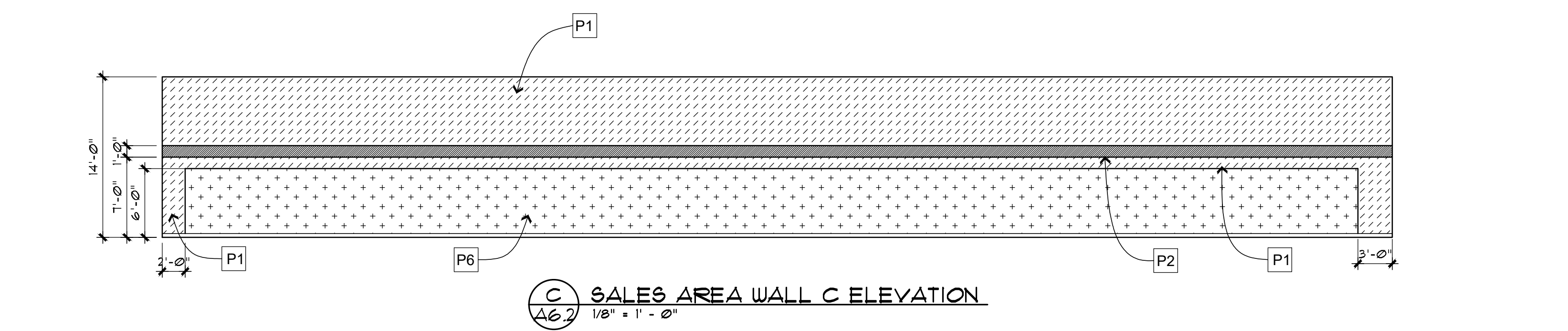
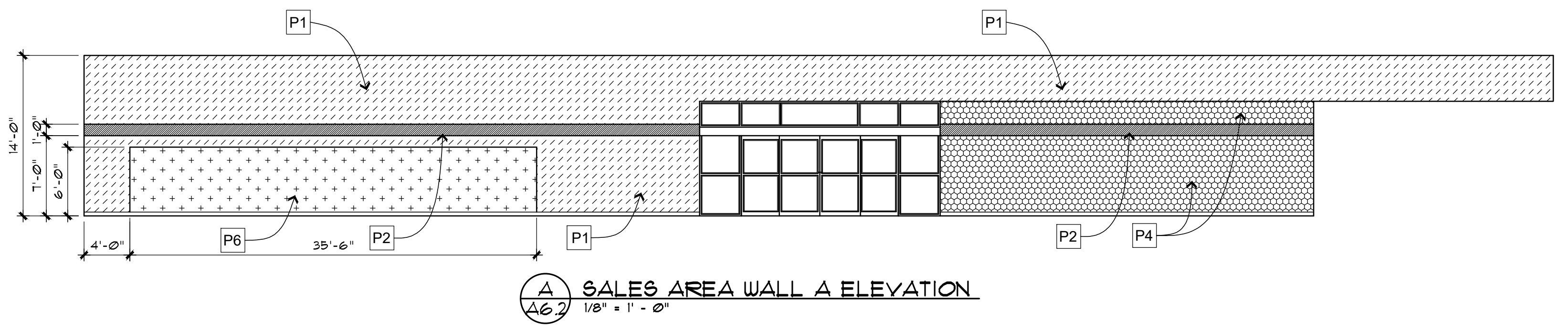

**REQUIRED NATIONAL ACCOUNTS FOR ENGINEERING AND CONSTRUCTION MATERIAL TESTING**

COMPANY	CONTACTS	PHONE #	
ATC ASSOCIATES, INC.	LESLIE GREENWOOD	205-733-8775 leslie.greenwood@atcg.com	www.atcassociates.com
BUILDING AND EARTH SCIENCES INC.	MATT ADAMS	205-836-6300 dollargeneral@buildingandearth.com	www.buildingandearth.com
EAS PROFESSIONALS, INC.	JERRY MARRONE	864-234-7368 dollargeneral@eas-pro.com	www.eas-pro.com
PROFESSIONAL SERVICE INDUSTRIES, INC. (PSI)	TERESA HEBNER	770-424-6200 #3030 teresa.hebner@psiusa.com	www.psiusa.com
TERRACON	JOHN MEADOW	770-623-0755 #353 dollargeneral@terracon.com	www.terracon.com

NOTE: MATERIAL TESTING IS REQUIRED ON ALL TRIPLE NET LEASES.

**PROTOTYPE MANAGEMENT TEAM**

COMPANY	CONTACTS	PHONE #	
MJM ARCHITECTS	GARY CONWAY	615-244-8170 dg@mjmarch.com	www.mjmarch.com
ENTECH	MITCH SIMPSON	615-373-2640 email@entechtn.com	www.entechtn.com

**NATIONAL ACCOUNT & CONTACT INFORMATION SUBJECT TO CHANGE**

VERIFY EXTENTS OF FINISHED WALLS WITH FINAL FIXTURE PLAN. ONCE FIXTURES ARE INSTALLED, THERE SHOULD BE NO VISIBLE UNFINISHED WALLS.

WALL PAINT LEGEND			
	P1 SW1065 "ARGOS"		P3 SW1005 "PURE WHITE"
	P2 SW6991 "BLACK MAGIC"		P4 SW6910 "DAISY"
	P5 PREFINISHED WHITE METAL LINER PANELS (EXPOSED)		P6 DENOTES TAPED AND MUDDING ONLY

PAINT EXPOSED CEILING STRUCTURE AND ALL BUILDING ELEMENTS INCLUDING CONDUITS, ETC. SW1005 PURE WHITE

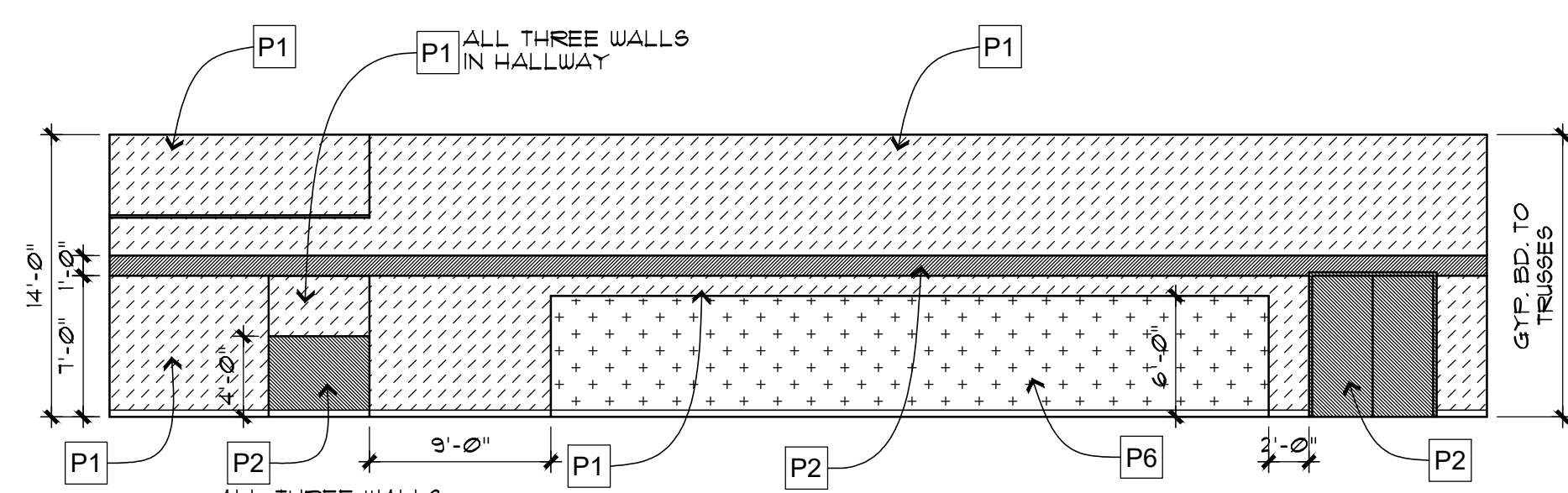
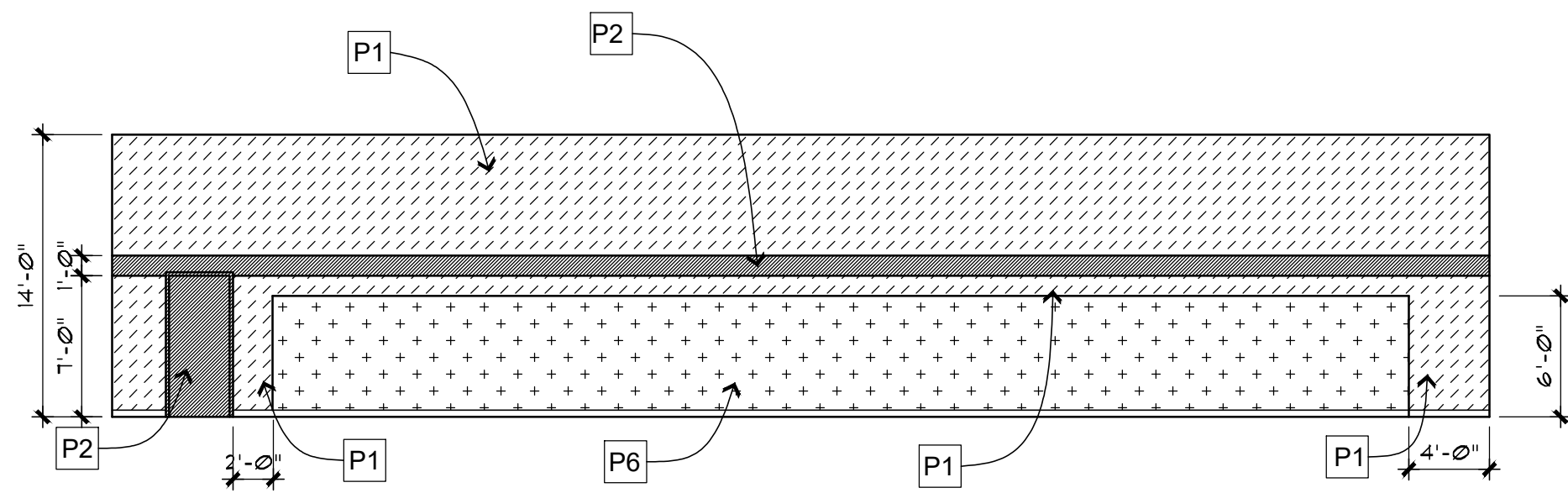

BASS SECURITY PARTS	
402-1/2B-26D	IVES WALL STOP
54-U632D	BURNS PUSH PLATE
8400-S32D-8X34	IVES KICK PLATE
5410-32D-26D-GRIF	BURNS FULL PLATE
W10S-DANE-626	FALCON PASSAGE LEVERSET
W581FD-DANE-626	FALCON STOREROOM LEVERSET
2610-28	VON DUPRIN GUARD-X EXIT ALARM LOCK
70158C8-26D*	IICO RIM CYLINDER
2609**	VON DUPRIN GUARD-X DOUBLE DOOR STRIKE
DDH-2250**	DETEX DOUBLE DOOR HOLDER
5400	HAGAR DOOR CLOSER
TA3310FC	TACO DOOR VIEWER
D81000MB	DOOR SCOPE (FOR EXTERIOR RECEIVING DOOR)
452B26D-4	IVES 4" DOOR HOLDER
608Z	8" DOOR HOLDER
B155	BOBRICK 24 OZ. SOAP DISPENSER
A-24x36	GAMCO 24"x36" ANGLE FRAMED MIRROR
B2140	BOBRICK DBL TOILET TISSUE DISP.
B253	BOBRICK PAPER TOWEL DISPENSER
1509x36	GAMCO 1 1/2"x36" GRAB BAR
1509x42	GAMCO 1 1/2"x42" GRAB BAR
1509x18	GAMCO 1 1/2"x18" GRAB BAR (MOUNTED VERT.)
1108AV-3FT	3 FOOT DOOR SWEEP
1108AV-4FT	4 FOOT DOOR SWEEP
M6-1	GAMCO MOP HOLDER
425HD-6FT	NATIONAL GUARD HD THRESHOLD (FOR EXTERIOR RECEIVING DOOR)
8928AV-84INCH	WEATHERSTRIPPING

\* MUST HAVE ONE RIM PER EXIT DEVICE  
\*\* MUST HAVE DOUBLE DOOR STRIKE AND TWO DOUBLE DOOR HOLDERS FOR ALL DOUBLE EXIT DOORS.

BASS SECURITY SERVICES, INC. 888-714-3400 EXT. 2024

JOHN P. WATKINS, ARCHITECT  
56 HILLMARK DRIVE  
COLUMBIA, SOUTH CAROLINA 29210

**Craig A. Otto**  
ARCHITECT, INC.  
DESIGN • PLANNING • ARCHITECTURE

5044 Augusta Road  
Lexington, South Carolina 29072  
Phone (803) 957-9004  
Fax (803) 957-2050

No.	Revisions	Date

All rights reserved. This drawing and the design shown thereon are copyrighted as prescribed by the laws of the United States and are the sole property of Craig A. Otto, Architect, Inc. Anyone duplicating, reproducing, or causing to be reproduced these drawings or the design thereon without permission of the architect will be subject to legal action.

Project Title **DOLLAR GENERAL #23725**  
US 421 S, LILLINGTON, NC

Drawing Title **VENDORS PARTS SCHEDULES AND INTERIOR ELEVATIONS**

Consultant

Seal:

Date: DECEMBER 8, 2021  
Drawn By: OTTO  
Drawing No.: **A6.2**

**GENERAL REQUIREMENTS**

- 1. THE STRUCTURE DESCRIBED BY THESE DOCUMENTS IS INTENDED TO WORK AS A COMPLETED STRUCTURE. THE CONTRACTOR IS SOLELY RESPONSIBLE FOR THE MEANS, METHODS, TECHNIQUES, SEQUENCES AND PROCEDURES OF CONSTRUCTION INCLUDING TEMPORARY SHORING, BRACING, AND TEMPORARY SUPPORTS. THE CONTRACTOR IS ALSO RESPONSIBLE FOR COORDINATION OF HIS OR HER WORK WITH ALL OTHER TRADES, AND FOR PERFORMING ALL WORK IN A SAFE AND SATISFACTORY MANNER.
- 2. ENGINEER/ARCHITECT'S APPROVAL MUST BE OBTAINED IN WRITING FOR ALL DEVIATIONS AND SUBSTITUTIONS. THE ENGINEER/ARCHITECT IS NOT RESPONSIBLE FOR THE FAILURE OF THE CONTRACTOR TO BUILD THE STRUCTURE ACCORDING TO THE DOCUMENTS.
- 3. THE CONTRACTOR SHALL VERIFY EXISTING CONDITIONS AND DIMENSIONS PRIOR TO DETAILING, FABRICATION AND CONSTRUCTION; AND SHALL NOTIFY THE ENGINEER/ARCHITECT OF ANY DISCREPANCIES.
- 4. FOR ADDITIONAL INFORMATION, SEE THE PROJECT SPECIFICATIONS. IN THE CASE OF A DISCREPANCY, THE MORE STRINGENT REQUIREMENTS SHALL GOVERN UNLESS APPROVED OTHERWISE IN WRITING BY THE ENGINEER.
- 5. OWNER SHALL EMPLOY AND PAY A QUALIFIED INDEPENDENT TESTING AGENCY TO PERFORM TESTS AND INSPECTIONS SPECIFIED IN OTHER SECTIONS, AND THOSE REQUIRED BY AUTHORITIES HAVING JURISDICTION, INCLUDING ALL SPECIAL INSPECTIONS. CONTRACTOR IS RESPONSIBLE FOR SCHEDULING INSPECTIONS AND TESTS. RETESTING: OWNER SHALL PAY FOR RETESTING WHERE RESULTS OF INSPECTIONS AND TESTS PROVE UNSATISFACTORY AND INDICATE NONCOMPLIANCE WITH REQUIREMENTS. THE OWNER RESERVES THE RIGHT TO DEDUCT COSTS OF RETESTING FROM CONSTRUCTION CONTRACT COSTS.
- 6. SECTIONS SHOWN ON STRUCTURAL DRAWINGS PROVIDE TYPICAL DETAILING INFORMATION THAT SHALL BE APPLIED TO ALL SIMILAR AND LIKE CONDITIONS UNLESS SHOP DRAWINGS SHALL DETAIL ALL CONDITIONS IN ACCORDANCE WITH PROJECT REQUIREMENTS.
- 7. COORDINATE FLOOR, ROOF, AND WALL OPENING SIZES AND LOCATIONS WITH ARCHITECTURAL, MECHANICAL, ELECTRICAL, PLUMBING, AND CIVIL PLANS. NOTIFY THE ENGINEER OF ANY DISCREPANCIES.

**EARTHWORK**

- 1. FOR ADDITIONAL INFORMATION, SEE S0.1
- 2. AN INDEPENDENT TESTING AGENCY SHALL BE RETAINED BY THE OWNER TO PERFORM TESTING OF EARTHWORK. ALL FOOTING AND SLAB SUB-GRADES SHALL BE INSPECTED, AND TESTED IF REQUIRED, BY THE TESTING AGENCY. ALL FILL PLACEMENT AND COMPACTION SHALL BE MONITORED BY THE TESTING AGENCY. ALL BACKFILL MATERIALS SHALL BE APPROVED BY TESTING AGENCY PRIOR TO PLACEMENT. THE ENGINEER IS NOT RESPONSIBLE FOR SUBSURFACE CONDITIONS ENCOUNTERED IN THE FIELD CONTRARY TO THOSE ASSUMED FOR DESIGN.
- 3. THE FOUNDATIONS ARE DESIGNED FOR 2000 PSF ALLOWABLE SOIL BEARING PRESSURE. CAPACITY SHALL BE APPROVED BY THE TESTING AGENCY PRIOR TO CONCRETE PLACEMENT.
- 4. SUBGRADE PREPARATION FOR SLAB ON GRADE SHALL BE PERFORMED IN ACCORDANCE WITH GEOTECHNICAL ENGINEERING REPORT. THE CONTRACTOR SHALL BE RESPONSIBLE FOR LOCATING AND PROTECTING ALL SERVICE AND UTILITY LINES ON THE SITE.
- 5. REFER TO PROJECT GEOTECHNICAL REPORT FOR ADDITIONAL INFORMATION. IN CASE OF DISCREPANCY, THE GEOTECHNICAL REPORT SHALL GOVERN UNLESS APPROVED OTHERWISE IN WRITING BY THE ENGINEER.

**CAST-IN-PLACE CONCRETE**

- 1. FOR ADDITIONAL INFORMATION, SEE S0.1.
- 2. ALL WORK SHALL COMPLY WITH ACI 301, "SPECIFICATIONS FOR STRUCTURAL CONCRETE FOR BUILDINGS"; ASTM C 94; AND CRSI'S "MANUAL OF STANDARD PRACTICE."
- 3. DESIGN OF ALL FORMWORK AND BRACING SHALL BE THE RESPONSIBILITY OF THE CONTRACTOR.
- 4. DEFORMED REINFORCING BARS - ASTM A618, GRADE 60.
- 5. WELDED STEEL WIRE FABRIC - ASTM A1064, FLAT SHEETS, NOT ROLLS. LAP A MINIMUM OF ONE CROSS WIRE SPACING PLUS 2 INCHES.
- 6. FOUNDATIONS
- 7. ALL EXCAVATIONS SHALL BE PROPERLY BACKFILLED, BUT NOT BEFORE CONCRETE HAS ATTAINED FULL DESIGN STRENGTH. NO BACKFILL SHALL BE PLACED AGAINST CONCRETE WALLS UNTIL CONCRETE HAS ATTAINED FULL 28-DAY STRENGTH.
- 8. SLEEVE PLUMBING OPENINGS IN SLABS BEFORE PLACING CONCRETE AND BEND REINFORCING AROUND SLEEVES. CORING NOT PERMITTED IN FLOOR SLABS, UNLESS APPROVED BY STRUCTURAL ENGINEER. DO NOT PLACE PIPES OR DUCTS EXCEEDING ONE-THIRD THE SLAB OR WALL THICKNESS WITHIN THE SLAB OR WALL UNLESS SPECIFICALLY SHOWN AND DETAILED ON STRUCTURAL DRAWINGS. SEE MECHANICAL, ELECTRICAL, AND PLUMBING DRAWINGS FOR LOCATION OF SLEEVES, ACCESSORIES, ETC.
- 9. REINFORCING STEEL
- 10. PROVIDE DEFORMED REBAR EMBEDMENT, LAP SPLICES, AND HOOKS AS DETAILED ON DRAWINGS. IF NOT SPECIFIED, FOLLOW ACI 301 STANDARD DETAILING REQUIREMENTS FOR THE APPROPRIATE CONDITIONS WITH CLASS B LAPS.
- 11. REINFORCING STEEL MARKED "CONTINUOUS" SHALL BE LAPPED WITH CLASS "B" LAP SPLICE UNLESS SPECIFICALLY DETAILED OTHERWISE. PROVIDE CONTINUOUS REINFORCEMENT WHERE EVER POSSIBLE; SPLICE ONLY AS SHOWN OR APPROVED; STAGGER SPLICES WHERE POSSIBLE; USE TENSION SPLICE (CLASS "B") UNLESS NOTED OTHERWISE. DOWELS SHALL MATCH THE SIZE AND SPACING OF THE WALL OR COLUMN SPECIFIED REINFORCEMENT AND SHALL BE LAPPED WITH TENSION SPLICES (CLASS "B"), UNLESS NOTED OTHERWISE.
- 12. HORIZONTAL REINFORCEMENT IN FOOTINGS, TURNDOWN SLABS, AND WALLS SHALL BE CONTINUOUS AROUND CORNERS. HORIZONTAL REINFORCEMENT SHALL CONTINUE AT BENDS AND CORNERS WITH BEND TO FAR FACE OF INTERSECTING ELEMENT IN EACH DIRECTION. ADDITIONAL HORIZONTAL CORNER BARS OF SAME SIZE AND SPACING MAY BE PROVIDED. PROVIDE CORNER BARS AT ALL TURNDOWN SLAB CORNERS AND C.I.P. CONCRETE WALL CORNERS. PROVIDE LAP SPLICE 48 TIMES BAR DIAMETER. WHERE PERPENDICULAR WALLS ARE NOT POURED CONTINUOUS, PROVIDE A KEYED JOINT WITH CORNER BARS.
- 13. PROVIDE SPACERS, CHAIRS, BOLTERS, ETC. AS REQUIRED TO ASSEMBLE, PLACE, AND SUPPORT ALL REINFORCING IN PLAN.

**STRUCTURAL STEEL**

- 1. COMPLY WITH AISC 360 "SPECIFICATION FOR STRUCTURAL STEEL BUILDINGS", LATEST EDITION. BOLTED CONNECTIONS SHALL COMPLY WITH RCSC'S "SPECIFICATION FOR STRUCTURAL JOINTS USING HIGH-STRENGTH BOLTS", LATEST EDITION.
- 2. STRUCTURAL-STEEL SHALL CONFORM TO THE FOLLOWING SPECIFICATIONS:
  - WIDE FLANGE SHAPES - ASTM A992, GRADE 50
  - HSS ROUND - ASTM A500 GRADE C, Fy=46 KSJ
  - OTHER SHAPES, PLATES, AND BARS - ASTM A36, Fy=36 KSJ
  - ANCHOR RODS, BOLTS, NUTS - ASTM F1554, GRADE 55, S-1 SUPPLEMENT, UNHEADED RODS.
  - 3. BOLTS, NUTS, AND WASHERS: ASTM A325-N, TYPE 1, HIGH-STRENGTH HEAVY HEX STEEL STRUCTURAL BOLTS, HEAVY HEX CARBON-STEEL NUTS, AND HARDENED CARBON-STEEL WASHERS, UNCOATED.
  - 4. WELDS: E70XX PER AWS.
  - 5. PRIMER: LEAD-FREE AND CHROMATE-FREE, NONASPHALTIC, RUST-INHIBITING PRIMER.
  - 6. GROUT: ASTM C1107, NONMETALLIC, SHRINKAGE RESISTANT, PREMIXED, MINIMUM COMPRESSIVE STRENGTH = 5000 PSI.
  - 7. FABRICATE STRUCTURAL STEEL ACCORDING TO AISC SPECIFICATIONS AND TOLERANCE LIMITS OF AISC'S "CODE OF STANDARD PRACTICE FOR STEEL BUILDINGS AND BRIDGES" FOR STRUCTURAL STEEL.
  - 8. SHOP PRIMING: PREPARE SURFACES ACCORDING TO SSPC-SP 2 OR SSPC-SP 3. SHOP PRIME STEEL TO A DRY FILM THICKNESS OF AT LEAST 2.0 MILS. DO NOT PRIME SURFACES TO BE EMBEDDED IN CONCRETE OR MORTAR OR TO BE FIELD WELDED.
  - 9. ERECT STRUCTURAL STEEL ACCORDING TO AISC SPECIFICATIONS AND WITHIN ERECTION TOLERANCES OF AISC'S "CODE OF STANDARD PRACTICE FOR STEEL BUILDINGS AND BRIDGES."
  - 10. SET BASE AND BEARING PLATES ON WEDGES, SHIMS, OR SETTING NUTS. TIGHTEN ANCHOR BOLTS, CUT OFF WEDGES OR SHIMS FLUSH WITH EDGE OF PLATE, AND PACK GROUT SOLIDLY BETWEEN BEARING SURFACES AND PLATES.
  - 11. PROVIDE 3" CONCRETE COVER OVER ALL STEEL BELOW GRADE CONNECTIONS.
  - 12. BOLTED CONNECTIONS SHALL CONFORM TO RCSC'S "SPECIFICATION FOR STRUCTURAL JOINTS USING ASTM A325 OR A490 BOLTS."
  - 13. WELDING SHALL CONFORM TO AWS D1.1 "STRUCTURAL WELDING CODE-STEEL", LATEST EDITION. ALL WELDS MUST BE MADE BY CERTIFIED WELDERS. PROVIDE MINIMUM FILLET WELD SIZES PER AISC 360 TABLE J2.4, UNLESS SPECIFICALLY NOTED OTHERWISE.
  - 14. ALL BOLTED CONNECTIONS SHALL BE SNUG-TIGHTENED JOINTS USING 3/4" DIAMETER A325-N BOLTS WITH THREADS INCLUDED IN THE SHEAR PLANE. UNLESS ALL CONNECTIONS SHALL BE DOUBLE ANGLE CONNECTIONS CITED FROM TABLE 10-1, OR TABLE 10-2, AISC STEEL CONSTRUCTION MANUAL, UNLESS NOTED. UNLESS REACTIONS ARE NOTED ON PLAN, CONNECTIONS SHALL DEVELOP AT LEAST ONE-HALF OF THE MAXIMUM TOTAL UNIFORM LOAD CAPACITY TABULATED IN THE MANUAL FOR THE GIVEN SHAPE AND SPAN OF THE BEAM. AS A MINIMUM, ALL SHEAR CONNECTIONS SHALL CONTAIN AT LEAST THE NUMBER OF ROWS OF 3/4" DIAMETER A325-N BOLTS (AT 3" PITCH) AS CAN BE FIT IN A CLIP ANGLE OF ONE-HALF THE BEAM T-DISTANCE IN LENGTH.

**ROUGH CARPENTRY**

- 1. DRESSED LUMBER, S4S, 19 PERCENT MAXIMUM MOISTURE CONTENT FOR 2-INCH THICKNESS OR LESS, MARKED WITH GRADE STAMP OF INSPECTION AGENCY.
- 2. PRESERVE-TREATED MATERIALS: AMPA C2 LUMBER AND AMPA C9 PLYWOOD, LABELED BY AN INSPECTION AGENCY APPROVED BY AISC'S BOARD OF REVIEW. AFTER TREATMENT, KILN-DRY LUMBER AND PLYWOOD TO 19 AND 15 PERCENT MOISTURE CONTENT, RESPECTIVELY. TREAT INDICATED ITEMS AND THE FOLLOWING:
  - A. WOOD MEMBERS IN CONTACT WITH ROOFING, FLASHING, VAPOR BARRIERS, AND WATERPROOFING.
  - B. CONCEALED MEMBERS IN CONTACT WITH MASONRY OR CONCRETE.
- 3. CONCEALED BOARDS: 19 PERCENT MAXIMUM MOISTURE CONTENT.
- 4. JOISTS, BEAM HEADERS: SOUTHERN PINE: NO. 2.
- 5. RAFTERS: SOUTHERN PINE: NO. 2.
- 6. STUDS: SPRUCE-PINE-FIR NO.2. SPF'S OR SPF(S) NOT ALLOWED.
- 7. LVL: ALL LVL MEMBERS TO BE 1.75" WIDE EACH SINGLE MEMBER AND Fb=2,600 PSI E=1.9MPsi
- 8. MISCELLANEOUS LUMBER: NO. 3 OR STANDARD GRADE OF ANY SPECIES FOR NAILERS, BLOCKING, AND SIMILAR MEMBERS.
- 9. ALL KING STUDS SHALL BE CONTINUOUS TO SLAB ON GRADE, TYP.
- 10. WOOD-BASED STRUCTURAL-USE PANELS: DOC PS 2. PROVIDE PLYWOOD COMPLYING WITH DOC PS 1, WHERE PLYWOOD IS INDICATED.
  - A. FACTORY MARK PANELS EVIDENCING COMPLIANCE WITH GRADE REQUIREMENTS.
  - B. PANELS WITH SPAN RATINGS REQUIRED BY SUPPORT SPACING INDICATED.
  - C. WALL SHEATHING: 1/2", APA-RATED CDX PLYWOOD OR OSB SHEATHING, EXPOSURE 1. BLOCK ALL PANEL EDGES
  - D. ROOF SHEATHING: 5/8", APA-RATED CDX PLYWOOD SHEATHING, EXTERIOR. INSTALL SHEATHING WITH FACE GRAIN ACROSS SUPPORTS. ATTACH SHEATHING WITH 10d NAILS AT 6" O.C. ALONG PANEL EDGES AND AT 12" O.C. AT INTERMEDIATE SUPPORTS. PROVIDE H-CLIPS AT MID SPAN OF PANELS.
- 11. FIT ROUGH CARPENTRY TO OTHER CONSTRUCTION; SCRIBE AND COPY FOR ACCURATE FIT. CORRELATE LOCATION OF FURRING, BLOCKING, AND HEADER SUPPORTS TO ALLOW ATTACHMENT OF OTHER CONSTRUCTION.
- 12. PROVIDE A MINIMUM OF 3" BEARING AT EACH END OF WOOD MEMBERS UN.O.
- 13. WHEN NAILING IS NOT SHOWN IN PLANS, NAIL PER TABLE 2304.10.1 OF THE 2015 INTERNATIONAL BUILDING CODE.
- 14. COORDINATE LAYOUT OF FRAMING MEMBERS WITH ALL TRADES TO ENSURE THAT JOISTS, RAFTERS AND PLATES ARE NOT EXTENSIVELY NOTCHED, CUT, OR BORED. REFER TO INTERNATIONAL RESIDENTIAL CODE CHAPTER 23, ICC-600 AND AITC MANUAL FOR ALLOWABLE CUTTING, NOTCHING, AND BORING OF FRAMING MEMBERS. TRUSSES SHALL NOT BE CUT, NOTCHED, OR BORED WITHOUT ENGINEER'S APPROVAL.
- 15. ALL FIRE RETARDANT TREATED WOOD SHALL HAVE HOT-DIPPED ZINC-COATED GALVANIZED HARDWARE.

**METAL-PLATE-CONNECTED WOOD TRUSSES**

- 1. ENGINEER, FABRICATE, AND ERECT METAL-PLATE-CONNECTED WOOD TRUSSES TO WITHSTAND DESIGN LOADS WITHOUT EXCEEDING DEFLECTION LIMITS OF ANSI/TPI 1, "NATIONAL DESIGN STANDARD FOR METAL-PLATE-CONNECTED WOOD TRUSS CONSTRUCTION."
- 2. IN ADDITION TO PRODUCT DATA, SUBMIT SHOP DRAWINGS AND STRUCTURAL ANALYSIS DATA, SIGNED AND SEALED BY A QUALIFIED PROFESSIONAL ENGINEER ENGAGED BY THE FABRICATOR WHO IS LOCATED IN THE STATE WHERE PROJECT IS LOCATED.
- 3. ENGAGE A FABRICATOR WHO PARTICIPATES IN A RECOGNIZED QUALITY-ASSURANCE PROGRAM THAT INVOLVES INSPECTION BY AN INDEPENDENT INSPECTING AND TESTING AGENCY ACCEPTABLE TO AUTHORITIES HAVING JURISDICTION.
- 4. COMPLY WITH ANSI/TPI 1; TPI HIB, "COMMENTARY AND RECOMMENDATIONS FOR HANDLING INSTALLING & BRACING METAL PLATE CONNECTED WOOD TRUSSES"; AND AFPA'S "NATIONAL DESIGN SPECIFICATION FOR WOOD CONSTRUCTION" AND ITS "SUPPLEMENT," DIMENSION LUMBER: COMPLY WITH DOC PS 20, "AMERICAN SOFTWOOD LUMBER STANDARD," ANY SPECIES, GRADED VISUALLY OR MECHANICALLY. ALL MEMBERS SHALL BE NO. 2 KD SOUTHERN YELLOW PINE (OR BETTER). TOP AND BOTTOM CHORDS SHALL BE 2x6 MINIMUM.
- 5. CONNECTOR PLATES: STRUCTURAL-QUALITY STEEL SHEET, ZINC COATED, COMPLYING WITH ASTM A 653, GRADE 33, 680 (ASTM A 653M, GRADE 230, Z180) COATING DESIGNATION; STRUCTURAL, COMMERCIAL, OR LOCK- FORMING QUALITY, AS STANDARD WITH MANUFACTURER'S FINISH.
- 6. FASTENERS: HOT-DIP GALVANIZED PER ASTM A 153 OR STAINLESS STEEL, TYPE 304 OR 316, WHERE EXPOSED TO WEATHER OR TO HIGH RELATIVE HUMIDITIES. SIZE AND TYPE INDICATED.
- 7. METAL FRAMING ANCHORS: MANUFACTURED FROM HOT-DIP, ZINC-COATED STEEL SHEET COMPLYING WITH ASTM A 653, G60 (ASTM A 653M, Z180) COATING DESIGNATION; STRUCTURAL, COMMERCIAL, OR LOCK- FORMING QUALITY, AS STANDARD WITH MANUFACTURER'S FINISH.
- 8. FABRICATE WOOD TRUSSES WITHIN MANUFACTURING TOLERANCES OF ANSI/TPI 1 AND CONNECT TRUSS MEMBERS BY METAL CONNECTOR PLATES.
- 9. INSTALL AND BRACE TRUSSES ACCORDING TO RECOMMENDATIONS OF TPI. SPACE TRUSSES AT 24" O.C. MAX; INSTALL PLUMB, SQUARE, AND TRUE TO LINE, AND SECURELY FASTEN TO SUPPORTING CONSTRUCTION.
- 10. ANCHOR ALL TRUSSES TO WOOD PLATE WITH SIMPSON H2.5A HURRICANE TIES UNLESS NOTED OTHERWISE. ANCHOR ALL GIRDER TRUSSES TO WOOD PLATE AND STUDS WITH SIMPSON VGT/HDU4 TIEDOWNS UNLESS NOTED OTHERWISE.
- 11. INSTALL AND FASTEN PERMANENT BRACING DURING TRUSS ERECTION. ANCHOR ENDS OF PERMANENT BRACING WHERE TERMINATING AT WALLS OR BEAMS.
- 12. INSTALL ALL WOOD TRUSSES WITHIN INSTALLATION TOLERANCES OF ANSI/TPI 1. FIELD REPAIR OF DAMAGED TRUSSES MUST BE APPROVED IN WRITING BY THE TRUSS ENGINEER AND ENGINEER OF RECORD.
- 13. DO NOT ALTER, CUT, OR REMOVE TRUSS MEMBERS. FIELD REPAIR OF DAMAGED TRUSSES MUST BE APPROVED IN WRITING BY THE TRUSS ENGINEER AND ENGINEER OF RECORD.
- 14. REMOVE AND REPLACE WOOD TRUSSES THAT ARE DAMAGED OR DEFICIENT. IF TRUSSES TOPPLE OR DOMINO DURING ERECTION, DISCARD ALL DOMINATED TRUSSES AND REPLACE WITH NEW TRUSSES.
- 15. GENERAL CONTRACTOR SHALL COORDINATE ALL MECHANICAL EQUIPMENT W/ ROOF TRUSS MANUFACTURER TO ASSURE TRUSSES ARE PROPERLY FABRICATED TO ACCOMMODATE WEIGHTS AND REQUIRED ROOF OPENINGS. TRUSS MANUFACTURER TO COORDINATE WITH MECHANICAL, PLUMBING & FIRE SUPPRESSION DRAWINGS FOR ADDITIONAL CONCENTRATED LOADS DUE TO DOMESTIC WATER AND SPRINKLER SUPPORTS.
- 16. TRUSS SUPPLIER IS TO PROVIDE PLAN AND PROCEDURES FOR INSTALLING, SECURING AND BRACING OF ALL TRUSSES. THE CONTRACTOR SHALL PROVIDE ADEQUATE TEMPORARY BRACING FOR THE TRUSSES DURING ERECTION.
- 17. TRUSS SUPPLIER SHALL PROVIDE TRUSS BLOCKS CAPABLE OF TRANSFERRING LATERAL LOADS AS NOTED ON PLANS AND/OR DETAILS.
- 18. MEMBERS OF THE GABLE END WALL TRUSSES SHALL BE DESIGNED FOR COMPONENT WIND FORCES AGAINST THE EXPOSED FACE OF THE TRUSS.
- 19. ALL TRUSS-TO-TRUSS AND TRUSS-TO-BEAM CONNECTIONS SHALL BE DESIGNED BY TRUSS MANUFACTURER.

**STRUCTURAL ABBREVIATIONS:**

ABBREVIATION	DEFINITION	ABBREVIATION	DEFINITION
ARCH.	ARCHITECT	LLH	LONG LEG HORIZONTAL
B/XXX	BOTTOM OF XXX	LVH	LONG LEG VERTICAL
BOH	BOTTOM OF HEADER	LSH	LONG SIDE HORIZONTAL
BOS	BOTTOM OF STEEL	LSV	LONG SIDE VERTICAL
CL	CENTER LINE	LT. GA.	LIGHT GAUGE
CLR	CLEAR	ARCH.	ARCHITECT
CJ	CONTROL JOINT	MAX.	MAXIMUM
CMU	CONCRETE MASONRY UNIT	MECH.	MECHANICAL
COL	COLUMN	MIN.	MINIMUM
CONC.	CONCRETE	MSH	METAL STUD HEADER
CONN.	CONNECTION	NIC	NOT IN CONTRACT
CONT.	CONTINUOUS	NS	NEAR SIDE
DIA	DIAMETER	O.C.	ON CENTER
DWG	DRAWING	O.H.	OPPOSITE HAND
(E)	EXISTING	P.A.F	POWER-ACTUATED FASTENER
EA	EACH	PL	PLATE
EF	EACH FACE	P.T.	PRESSURE TREATED
ELEV.	ELEVATION	REF.	REFERENCE
EOS	EDGE OF SLAB	REINF.	REINFORCING
EQ	EQUAL	REQ'D	REQUIRED
E.W.	EACH WAY	R.O.	ROUGH OPENING
(F)	FUTURE	RTU	ROUGH TOP UNIT
F.FE	FINISHED FLOOR ELEVATION	SCHED.	SCHEDULE
FLR.	FLOOR	SM	SIMILAR
FIN.	FINISHED	SJ	SLAB JOINT
FOB	FACE OF BRICK	SOG	SLAB-ON-GRADE
FOC	FACE OF CONCRETE	T&B	TOP AND BOTTOM
FOM	FACE OF MASONRY	T/XXX	TOP OF XXX
FOS	FACE OF STUD	TOS	TOP OF STEEL
FS	FAR SIDE	TYP.	TYPICAL
FTGS.	FOOTINGS	U.N.O.	UNLESS NOTED OTHERWISE
GALV.	GALVANIZED	VERT.	VERTICAL
G.C.	GENERAL CONTRACTOR	V.I.F.	VERIFY IN FIELD
HDG	HOT-DIP GALVANIZED	W/	WITH
HORIZ.	HORIZONTAL	W.P.	WORK POINT
HS	HIGH STRENGTH	W.WF	WELDED WIRE FABRIC

**TABLE 2304.10.1 FASTENING SCHEDULE 2018**

DESCRIPTION OF BUILDING ELEMENTS	NUMBER & TYPE OF FASTENER	SPACING & LOCATION
ROOF		
1a. BLOCKING BETWEEN TRUSSES TO TOP PLATE OR OTHER FRAMING BELOW	3-8d COMMON (2 1/2"x0.131")	EACH END, TOENAIL
1b. BLOCKING BETWEEN TRUSS NOT AT THE WALL TOP PLATE, TO RAFTER OR TRUSS	3-8d COMMON (2 1/2"x0.131")	EACH END, TOENAIL END NAIL
1c. FLAT BLOCKING TO TRUSS AND WEB FILLER	16d COMMON (3 1/2"x0.162") @ 6" O.C.	FACE NAIL
2. ROOF TRUSS TO TOP PLATE (SEE IBC SECTION 2308.7.5, TABLE 2308.7.5)	3-10d COMMON (3"x0.148")	TOENAIL
WALL		
3. STUD TO STUD (NOT AT BRACED WALL PANELS)	16d COMMON (3 1/2"x0.162") 10d BOX (3"x0.128")	24" O.C., FACE NAIL 16" O.C., FACE NAIL
4. STUD TO STUD AND ABUTTING STUDS AT INTERSECTING WALL CORNERS (AT BRACED WALL PANELS)	16d COMMON (3 1/2"x0.162") 16d BOX (3 1/2"x0.135")	16" O.C., FACE NAIL 12" O.C., FACE NAIL
5. BUILT-UP HEADER (2" TO 2" HEADER)	16d COMMON (3 1/2"x0.162") 16d BOX (3 1/2"x0.135")	16" O.C. EACH FACE, FACE NAIL 12" O.C. EACH FACE, FACE NAIL
6. CONTINUOUS HEADER TO STUD	4-8d COMMON (2 1/2"x0.131")	TOENAIL
7. TOP PLATE TO TOP PLATE	16d COMMON (3 1/2"x0.162") 10d BOX (3"x0.128")	16" O.C., FACE NAIL 12" O.C., FACE NAIL
8. TOP PLATE TO TOP PLATE, AT END JOINTS	8-16d COMMON (3 1/2"x0.162") 4-8d COMMON (2 1/2"x0.131")	SEE NOTE 1 TOENAIL
9. STUD TO TOP OR BOTTOM PLATE	2-16d COMMON (3 1/2"x0.162")	END NAIL
10. TOP PLATES, LAPS AT CORNERS AND INTERSECTIONS	2-16d COMMON (3 1/2"x0.162")	FACE NAIL

NOTE:  
 1. EACH SIDE OF END JOINT, FACE NAIL (MINIMUM 24" LAP SPLICE LENGTH EACH SIDE OF END JOINT).  
 2. 32" O.C. FACE NAIL AT TOP AND BOTTOM STAGGERED ON OPPOSITE SIDES.  
 3. 24" O.C. FACE NAIL AT TOP AND BOTTOM STAGGERED ON OPPOSITE SIDES.

**REQUIRED VERIFICATION AND INSPECTION OF SOILS**

APPLICABLE TO PROJECT	INSPECTION OR EXECUTION TASKS PRIOR TO DECK PLACEMENT	CONTINUOUS DURING TASK LISTED	PERIODICALLY DURING TASK LISTED
X	1. VERIFY MATERIALS BELOW SHALLOW FOUNDATIONS ARE ADEQUATE TO ACHIEVE THE DESIGN BEARING CAPACITY.	-	X
X	2. VERIFY EXCAVATIONS ARE EXTENDED TO PROPER DEPTH AND HAVE REACHED PROPER MATERIAL.	-	X
X	3. PERFORM CLASSIFICATION AND TESTING OF COMPACTED FILL MATERIALS.	-	X
X	4. VERIFY USE OF PROPER MATERIALS, DENSITIES AND LIFT THICKNESSES DURING PLACEMENT AND COMPACTION OF COMPACTED FILL.	X	-
X	5. PRIOR TO PLACEMENT OF COMPACTED FILL, INSPECT SUBGRADE AND VERIFY THAT SITE HAS BEEN PREPARED PROPERLY.	-	X

**REQUIRED VERIFICATION AND INSPECTION OF WOOD**

APPLICABLE TO PROJECT	VERIFICATION AND INSPECTION TASK	CONTINUOUS DURING TASK LISTED	PERIODIC DURING TASK LISTED
X	1. VERIFY THAT WOOD MEMBERS ARE PROPER SPECIES AND GRADE NOTED ON PLAN AND ARE STAMPED ACCORDINGLY.	-	X
X	2. VERIFY WOOD MEMBER SIZE AND SPACING MATCHES PLAN.	-	X
X	3. VERIFY CONNECTIONS FOR SIZE OF FASTENER, GRADE OF FASTENER, AND SPACING.	-	X

**REQUIRED VERIFICATIONS AND TESTS OF CONCRETE CONSTRUCTION**

APPLICABLE TO PROJECT	VERIFICATION AND INSPECTION TASK	CONTINUOUS	PERIODIC	REFERENCED STANDARDS <sup>(a)</sup>	IBC REFERENCE
X	INSPECTION OF REINFORCEMENT AND VERIFY PLACEMENT.	-	X	ACI 318: Ch. 20, 25.3, 26.6.1-26.6.3	1908.4
X	1. INSPECTION ANCHORS CAST IN CONCRETE	-	X	ACI 318: 17.8.2	-
X	2. INSPECT ANCHORS POST-INSTALLED IN HARDENED CONCRETE MEMBERS. <sup>(b)</sup>				
	a. ADHESIVE ANCHORS INSTALLED IN HORIZONTALLY OR UPWARDLY INCLUDED ORIENTATIONS TO RESIST SUSTAINED TENSION LOADS	X	-	ACI 318: 17.8.2.4	-
	b. MECHANICAL ANCHORS AND ADHESIVE ANCHORS NOTE DEFINED IN 4.a.	-	-	ACI 318: 17.8.2	-
X	3. VERIFY USE OF REQUIRED DESIGN MIX.	-	X	ACI 318: Ch. 19, 26.4.3, 26.4.4	1904.1, 1904.2, 1908.2, 1908.3
X	4. PRIOR TO CONCRETE PLACEMENT, FABRICATE SPECIMENS FOR STRENGTH TEST. PERFORM SLUMP AND AIR CONTENT TESTS, AND DETERMINE THE TEMPERATURE OF THE CONCRETE.	X	-	ASTM C 172, ASTM C31 ACI 318: 26.5, 26.12	1908.10
X	5. INSPECT CONCRETE AND SHOTCRETE PLACEMENT FOR PROPER APPLICATION TECHNIQUES.	X	-	ACI 318: 26.5	1908.6, 1908.7, 1908.8
X	6. VERIFY MAINTENANCE OF SPECIFIED CURING TEMPERATURE AND TECHNIQUES.	-	X	ACI 318: 26.5-26.5.5	1908.9
X	7. INSPECT FORMWORK FOR SHAPE, LOCATION AND DIMENSIONS OF CONCRETE MEMBER BEING FORMED.	-	X	ACI 318: 26.11.1.2 (b)	-

FOR SI 1 INCH = 25.4 mm  
 (a) Where applicable, also see Section 1705.12 Special Inspection for Seismic Resistance.  
 (b) Specific requirements for special inspection shall be included in the research report for the anchor issued by an approved source in accordance with 17.8.2 in ACI 318, or other qualification procedures. Where specific requirements are not provided, special inspection requirements shall be specified by the registered design professional and shall be approved by the building official prior to the commencement of the work.

**DESIGN LOAD CRITERIA**

This analysis is made utilizing the *International Building Code*, 2018 edition.

ROOF DESIGN LOADS	
Dead Load	20 psf
Live Load	20 psf / Reducible
Total Load	40 psf
Net Uplift	10 psf
SNOW LOADS	
Ground Snow Load, P <sub>g</sub>	15 psf
RAIN INTENSITY, I	3.75 in/hr
WIND LOADS	
Basic Design Wind Speed, V	119 mph
Allowable Stress Design Wind Speed, V <sub>allow</sub>	92 mph
Wind Exposure	C
Internal Pressure Coefficient	+18, -18
Risk Category	II
Height & Exposure Adjustment, λ	1.0
Wind Directionality Factor, K <sub>d</sub>	0.85
Topographic Factor, K <sub>zt</sub>	1.0
ULTIMATE WIND PRESSURES	
COMPONENTS AND CLADDING	
ROOF (AREA = 100 SF)	
<b>ZONE 1 &amp; 2e</b>	<b>ZONE 2n, 2r &amp; 3e</b>
16 psf	-18.9 psf
16 psf	-54.9 psf
OVERHANG (AREA = 100 SF)	
<b>ZONE 1 &amp; 2e</b>	<b>ZONE 2n &amp; 2r</b>
16 psf	-41.6 psf
16 psf	-62.1 psf
WALL (AREA = 20 SF)	
<b>ZONE 4</b>	<b>ZONE 5</b>
25.9 psf	-34.0 psf
25.9 psf	-40.9 psf
SEISMIC LOADS	
Importance Factor, I <sub>e</sub>	1.0
Risk Category	II
Site Class	D
S <sub>v</sub> (Mapped)	0.131 g
S <sub>1</sub> (Mapped)	0.065 g
S <sub>rs</sub>	0.140 g
S <sub>rs1</sub>	0.104 g
Design Category	C
Basic Seismic Force-Resisting System	Bearing Wall
Resisting System	Light Frame Wood Walls w/ Structural Wood Shear Panels
Response Coefficient, C <sub>s</sub>	0.021
Response Modification Factor, R	6.5
Design Base Shear	15.1K
Analysis Procedure	Equivalent Lateral Force



FULLER STRUCTURAL, INC.  
 1350 C Cleveland St., Greenville, SC 29607  
 O: 864.235.3580 F: 864.235.3577  
 info@fullergroup.com -fullergroup.com  
 FULLER GROUP PROJECT # 21518

JOHN P. WATKINS, ARCHITECT  
 56 HILLMARK DRIVE  
 COLUMBIA, SOUTH CAROLINA 29210

Craig A. Otto  
 ARCHITECT, INC.

DESIGN • PLANNING • ARCHITECTURE

5044 Augusta Road  
 Lexington, South Carolina 29072  
 Phone (803) 957-9004  
 Fax (803) 957-2050



1) FOUNDATIONS

A. The soils supporting the foundation shall be prepared and compacted in accordance with a geotechnical testing based investigation and site specific recommendations provided by a Professional Engineer registered to practice in the State where the project is located.

B. The bearing materials shall be free of organic, expansive or corrosive material, and shall support the foundation in accordance with the following twenty five year criteria:

- 1. Maximum differential movement due to either settlement or heave shall not exceed 1/2" over a distance of 50 feet.
2. Maximum total movement due to either settlement or heave shall not exceed 1".

C. The foundations shall be of sufficient depth to bear below local frost depth where exposed, attain minimum design bearing pressure (2000 psf, U.N.O.), achieve sufficient protection from settlement or heave, and where adjacent to existing construction, avoid application of lateral earth pressure to adjacent construction.

2) SLAB ON GRADE

A. The subgrade for the slab on grade shall be compacted and prepared in accordance with a geotechnical testing based investigation and site specific recommendations provided by a Professional Engineer registered to practice in the State where the project is located. The subgrade shall provide a minimum of 100 pounds per cubic inch (pci) modulus of sub-grade reaction and shall be proof-rolled to ensure that there are no pumping or soft zones greater than 1/2" (ACI 302, "Guide for Concrete Floor Slab Construction").

B. The slab on grade shall conform to the latest editions of all applicable standards of the American Concrete Institute (ACI), the Building Code(s) enforced by the Authority Having Jurisdiction and these requirements. The slab on grade shall be a minimum of 4" thick and reinforced with a minimum 6" x 6" x W1.4 x W1.4 welded wire fabric located in the center of the slab.

3) CONCRETE CONTRACTOR QUALIFICATION:

A. The concrete contractor shall include in their bid package to the general contractor, sufficient data, including a minimum of three similar and successful projects that clearly indicates the concrete contractor's ability to successfully perform the work and to achieve the interior sales floor slab tolerances required in this specification. The concrete contractor's team shall have participated in the majority of these projects, and that team shall remain the same through the duration of this project.

4) CONCRETE MATERIALS:

A. Portland Cement: ASTM C 150, Type 1. Use one brand of cement throughout the project.

B. Coarse and fine aggregates: ASTM C 33. Combined aggregate gradation for slabs on grade and other designated concrete shall be 8% - 18% for large top size aggregates (1 1/2") or 8% - 22% for smaller top size aggregates (1" or 3/4") retained on each sieve below the top size and above the no. 100 sieve. Slabs on grade shall have a maximum aggregate size of 1 1/2" footings and piers 1" and beams 3/4".

C. Water: complying with ASTM C 94.

D. Air-entraining admixtures: Shall conform to ASTM C-260. Admixture manufacturer shall provide written certification that the air-entraining admixture is compatible with other required admixtures. All exterior slabs shall be air-entrained (5% - 7%). Acceptable products: Euclid Chemical AEA-92 or Air 40; BASF Micro Air; W.R. Grace Darvaair 1000 or Darvec. Note: Air-entraining admixture shall not be used on interior concrete.

E. Water-reducing admixture: Shall conform to ASTM C494, Type A and contain no more than 0.05% chloride ions. Acceptable products: Euclid Chemical Eacon series; BASF Pozzolith series; W.R. Grace WRDA or Daracem series.

F. Water-reducing, retarding admixture: Shall conform to ASTM C494, Type D, and contain no more than 0.05% chloride ions. Acceptable products: Euclid Chemical Retarder 75; BASF Pozzolith series; W.R. Grace Daradart 17.

G. High range water-reducing admixture (superplasticizer): Shall conform to ASTM C494, Type F or Type G and contain no more than 0.05% chloride ions. Acceptable products: Euclid Chemical Eacon 37; BASF Rheobuild 1000; W.R. Grace daracem-100.

H. Water-reducing, non-corrosive accelerating admixture: Shall conform to ASTM C494, Type C or E, and contain no more chloride ions than are present in municipal drinking water. The admixture manufacturer must have long-term, non-corrosive test data from an independent testing laboratory (of at least a year's duration) using an acceptable accelerated corrosion test method such as that using electrical potential measures. Acceptable products: Euclid Chemical Accelguard 80/90 or Accelguard NCA; BASF NC538 or Pozzotrac 20; W.R. Grace Polat.

- 1. Prohibited admixtures:
1. Calcium chloride or admixtures containing more than 0.05% chloride ions are not permitted.
2. Flyash is not permitted.

5) EVAPORATION RETARDER:

A. Waterborne, monomolecular film forming, manufactured for application to fresh concrete.

- 1. Acceptable products:
a. "Eucober" by Euclid Chemical - Phil Brandt 877-438-3826

6) CURING MATERIALS:

A. Exterior curing: All exterior concrete slabs shall be cured using a liquid membrane-forming curing compound. The liquid membrane-forming curing compound shall meet the requirements of ASTM C1315 with a maximum V.O.C. Content of 700 g/l.

- 1. Acceptable products:
a. "Super Rez Seal" or "Super Aqua Cure" by Euclid Chemical - Phil Brandt 877-438- 3826

B. Interior curing (building not enclosed/sales floor slab is placed first): The interior sales floor slab shall be cured using a reduced odor, dissipating liquid membrane forming curing compound that is formulated from hydrocarbon resins. The dissipating liquid membrane forming curing compound shall meet the requirements of ASTM C309 and V.O.C. contents in accordance to EPA 40 CFR, part 59, table 1, subpart D for concrete curing compounds with a maximum V.O.C. content of 350g/l.

- 1. Acceptable product:
a. "Kurez DR VOX" by Euclid Chemical - Phil Brandt 877-438-3826

C. Interior curing (building enclosed/sales floor slab is placed last): The interior sales floor slab shall be cured using a removable, low odor, fast drying liquid membrane forming curing compound. The removable liquid membrane forming curing compound shall meet the requirements of ASTM C309, AASHTO M 148, USDA compliance and V.O.C. contents in accordance to EPA 40 CFR, part 59, Table 1, subpart D for concrete curing compounds with a maximum V.O.C. Content of 350g/l.

- 1. Acceptable product:
a. "Kurez RC" by Euclid Chemical - Phil Brandt 877-438-3826

7) LIQUID DENSIFIER / SEALER FOR INTERIOR SALES FLOOR:

A. Liquid densifier / sealer shall be a sodium silicate / silicoanate blend. Manufacturer of liquid densifier and sealer must be contacted prior to bidding for pricing and application requirements.

- 1. Acceptable liquid densifier and sealer manufacturer:
a. "Euco Diamond Hard" by Euclid Chemical - Phil Brandt 877-438-3826
b. "RetroPlate 99" by RetroPlate Systems - Curtis Turnbull 888-942-3144

B. Approval: All general contractors bidding or negotiating a Dollar General project shall contact Euclid Chemical or RetroPlate to obtain a list of approved applicators located within the geographic region of the project. General contractors shall solicit and accept pricing only from those applicators as provided by Euclid Chemical or RetroPlate. The approved applicator selected for the initial application of liquid densifier / sealer shall be the same as for the joint filling and additional application of liquid densifier / sealer, and polishing process. Within ten days after completion of work, the approved applicator shall furnish Euclid Chemical or RetroPlate a copy of the invoice, as well as square footage and coverage rate data confirming that the specified application rates were achieved.

C. Project service: at least 10 days prior to application of liquid densifier and sealer, the general contractor shall notify the Euclid Chemical or RetroPlate representative for jobsite service. The representative will be on the project site during the first application of liquid densifier / sealer and will follow the project through to completion.

8) SEMI-RIGID POLYUREA JOINT FILLER:

A. UV Resistant, semi-rigid polyurea joint filler shall be a two (2) component, 100% solids compound, with minimum Shore "A" hardness of 80. Joint filler color shall match the adjacent concrete surface.

- 1. Acceptable semi-rigid polyurea joint filler manufacturer:
a. "Euco QWIKJoint UVR" by Euclid Chemical - See sheet T01 for contact info.

B. Non-UV Resistant, semi-rigid polyurea joint filler shall be a two (2) component, 100% solids compound, with a minimum Shore "A" hardness of 75. Joint filler color shall match the adjacent concrete surface.

- 1. Acceptable semi-rigid polyurea joint filler:
a. "CreteFill Pro 75" by CureCrete - See sheet T01 for contact info.

C. Approval: All general contractors bidding or negotiating a Dollar General project shall contact the Euclid Chemical company or Retroplate to obtain a list of approved applicators located within the geographic region of the project. General contractors shall solicit and accept pricing only from those applicators as provided by Euclid Chemical or RetroPlate. The approved applicator selected for the initial application of liquid densifier / sealer shall be the same as for the joint filling and additional application of liquid densifier / sealer and polishing process.

9) CONCRETE MIXES:

A. Comply with ACI 301 requirements for concrete mixtures.

B. Concrete mix design(s) shall be proportioned according to ACI 301, for normal-weight concrete determined by either laboratory trial mix or field test data as follows:

1. Compressive strength (28 days): 4000psi (27.6mpa), with a maximum water/cement ratio of .53, unless otherwise indicated on the drawings. Concrete materials included in the mix design shall be the same materials provided to the project, and shall be prepared by an independent testing laboratory approved by the owner. If sufficient backup data is not available, the laboratory mix design shall exceed the desired job strength of concrete by 1,200psi. Four copies of the mix design shall be submitted to the owner before concrete work begins.

2. Slump: Concrete containing mid or high range water reducer shall have a maximum slump of 5 1/2" for the interior sales floor slab and 8" (200 mm) for other areas. All other concrete shall not exceed 4 inches (100 mm) unless otherwise indicated on the drawings.

3. Adjustment to concrete mixes: Mix design adjustments may be requested by General Contractor when characteristics of materials, job conditions, weather, test results or other circumstances warrant; at no additional cost to owner and as accepted by owner. Laboratory test data for revised mix design and strength results must be submitted to and accepted by owner before using in work. Both the concrete testing and inspection agency and the concrete contractor shall satisfy themselves that the concrete mix design will produce a concrete which will meet the specifications for this project. In addition, the General Contractor and Concrete Contractor shall verify that the workability, finishability and setting times are appropriate for slab installations. Placement shall be made directly from concrete trucks by chute. If pumping of the concrete is contemplated for any special locations, the proportions established above shall not be altered to suit the capabilities of the pumping equipment. For concrete containing macro-synthetic fibers, adjustments required to provide required placement conditions may warrant use of additional water reducer. No additional water is permitted into concrete mixture after addition of macro-synthetic fibers.

4 Interior concrete sales floor: Concrete shall be designed to meet 4000 psi compressive strength @ 28 days and exhibit <math>\leq 0.04\%</math> shrinkage @ 28 days. The mix shall contain approximately 12 cubic feet of #4/7 aggregate (1-1 1/2" top size), the specified water reducing admixture and achieve a w/cm ratio of 0.53 (max.). Concrete shall be non air-entrained and in no case shall the concrete be designed for less than 4000 psi (27.6mpa) @ 28 days. Proposed mix design shall be similar to the following

Table with 2 columns: Prototype mix: Materials and Prototype mix. It lists specifications for Cement, Fly ash/slag, Coarse aggregate, Fine aggregate, Water content, Air content, Water Reducer, W/cm, Initial slump, and Final Slump.

10) FLOOR SLAB FINISH AND TOLERANCES:

A. General: Unless otherwise noted by owner, concrete sales floor slab shall be cast in one continuous placement. Concrete shall be placed, screeded, re-straightened, and finished as necessary to meet the FF and FL tolerance requirements. Do not wet concrete surfaces during finishing operations.

B. Trowel finish (sales floor): Apply a hard trowel finish to surfaces as follows:

1. Laser screeds, vibratory screeds, highway straightedges and wood ball floats shall be used to initiate screeding and floating process to form a uniform and open-textured surface plane before excess moisture or bleed water appears on the surface. A back-up laser screed is required during concrete placement of the interior sales floor slab. Remove excess water before starting floating operations. Do not further disturb surfaces before starting finishing operations

2. Highway straightedge operations shall continue before, during and after troweling operation, until specified floor tolerances are achieved.

3. Trowel finish with gas operated troweling machine with adjustable blades on all finishing equipment. Use steel-reinforced blades on ride-on power trowels. Trowel the surface sufficiently to produce a smooth, tight, abrasion resistant surface. Care shall be taken not to overwork or burn the surface. Use 6" wide finish style steel-reinforced blades on final passes. Finishing blades shall be in new condition and completely clean of any deleterious materials. Interior machine trowel finish shall be achieved within a 3' tolerance of all walls, columns and partitions.

4. Protection: Care shall be taken to protect the interior sales floor. Entrances shall include clean floor mats to prevent mud stains and all equipment on the floor shall be directed to prevent spills. Cutting oils, etc, are not allowed on the sales floor slab at any time during the construction process.

C. Comply with ACI117, "Specifications For Tolerances For Concrete Construction and Materials." Interior sales floor slab shall meet the requirements of a type 5, single course, hard steel-troweled finish as described in ACI 302.

1. All perimeter areas and edges of the concrete floor shall exhibit the same finish as the sales floor, including but not limited to, hallways, offices, restrooms, etc.

2. The general contractor is responsible for contracting with the testing laboratory for all costs associated with floor tolerance testing. A copy of the final floor tolerance report shall be provided by the general contractor to the owner within 24 hours of receiving the report from the testing laboratory. The sales floor slab shall conform to the following flatness and levelness criteria:

Flatness Overall Floor Flatness rating of at least 35

Levelness Overall Floor Levelness rating of at least 30

Tolerance Band for Entire Floor +/- 0.375 inch

D. Failure to achieve the above criteria shall be cause for replacement of the offending segments or grinding/polishing at no cost to the Owner or Tenant.

E. Trowel finish (other than sales floor): Apply a hard trowel finish to surfaces indicated and to floor and slab surfaces exposed to view or to be covered with resilient flooring, carpet, ceramic or quarry tile set over a cleavage membrane, paint, or another thin film-finish coating system.

F. Heavy broom finish: As noted on drawings.

11) CONCRETE PROTECTION AND CURING:

A. General: Normalize concrete set time and protect freshly placed concrete from premature drying and excessive cold or hot temperatures. Comply with ACI 305 for hot-weather protection and ACI 306 for cold-weather protection during curing. During concrete placement operations, ventilate and exhaust all fumes from construction equipment and heaters to avoid potential early concrete carbonation. Apply the specified curing compound as quickly as possible for maximum protection. For concrete placement during hot, dry and windy conditions, concrete contractor shall use evaporation retarder as per manufacturer's instructions to maintain a moist condition and to minimize plastic drying shrinkage cracking at the surface of the freshly placed concrete.

1. Curing - Exterior Slabs: All exterior concrete slabs shall be cured using the specified liquid membrane-forming curing compound. Per manufacturer's instructions, application shall be applied evenly and uniformly as soon as possible after final finishing. Surface shall be clean and damp, but not wet and can no longer be marred by walking workers. All applications shall be made by an approved applicator of the manufacturer, and when surface and air temperature is above 50° F. Apply "Super Rez Seal" or "Super Aqua Cure" at an application rate of 400sf/gallon. Begin curing immediately after finishing concrete, but not before free water has disappeared from concrete surface.

2. Curing - Interior slabs: The interior sales floor slab shall be cured using the specified dissipating or removable liquid membrane-forming curing compound. Per manufacturer's instructions, application shall be applied evenly and uniformly as soon as possible after final finishing. Surface shall be damp, but not wet and can no longer be marred by walking workers. All applications shall be made by an approved applicator of the manufacturer, and when surface and air temperature is above 50° f. Apply "Kurez DR VOX" (slab first) or "Kurez RC" (slab last) at an application rate of 350sf/gallon. Begin curing immediately after finishing concrete, but not before free water has disappeared from concrete surface.

12) CONTRACTION JOINTS IN SLABS-ON-GRADE:

A. Form weakened-plane contraction joints, sectioning concrete into areas as indicated on drawings. Contraction joints shall be sawn to a depth equal to at least one-fourth of the concrete thickness, as follows:

B. Sawed joints: All saw cutting shall be accomplished with a "Soft-Cut" saw and vacuum system equipped with a new blade and plate, as soon as the slab will support the weight of the saw and operator. Note: Concrete dust shall be removed completely and immediately. If chalk lines are used for sawcuts, all chalk remaining on the slab shall be removed completely and immediately after sawing.

13) INTERIOR SALES FLOOR SLAB PROTECTION:

A. Take the following measures to protect the interior sales floor slab:
1. Wrnp or "diaper" all motorized and hydraulic equipment to prevent fluid leaks
2. Provide non-marking tires on rubber tired vehicles or equip rubber tires with tire boots made of nylon fabric
3. Provide mats at all entrances to prevent mud stains

14) TIMING OF JOINT FILLER, LIQUID DENSIFER AND POLISHING PROCESS:

A. Do not commence installation of semi-rigid polyurea joint filler, liquid densifier and sealer or polishing processes until the building is completely enclosed, permanent power and lighting is operating and the building is thermostatically controlled. Installation of these materials shall commence approximately two weeks prior to "fixture date."

15) INSTALLATION OF SEMI-RIGID POLYUREA JOINT FILLER:

A. All General Contractors bidding or negotiating a Dollar General project shall contact Euclid Chemical or RetroPlate to obtain a list of approved applicators located within the geographic region of the project. General contractors shall solicit and accept pricing only from those applicators as provided by Euclid Chemical or RetroPlate. The approved applicator selected for the initial application of liquid densifier / sealer shall be the same as for the joint filling and additional application of liquid densifier / sealer.

B. Joint filler installation: Comply with recommendations in ACI 302 for use of joint filler as applicable to materials, applications, and conditions indicated.

C. Surface cleaning of joints: Clean out joints immediately before installing joint filler. Remove foreign material from joint substrates that could interfere with adhesion of joint filler by brushing, grinding, blast cleaning, mechanical abrading, or a combination of these methods to produce a clean, sound substrate capable of developing optimum bond with joint filler. Remove loose particles remaining from above cleaning operations by vacuuming or blowing out joints with oil-free compressed air. Also remove all lantance and form-release agents from concrete surface. Clean nonporous surfaces with chemical cleaners or other means that do not stain, harm substrates, or leave residues could interfere with adhesion of joint sealants. All surfaces to be filled shall be clean and dry.

D. For proper load transfer, joints must be filled full depth, but in no case should the joint filler be any less than 1" deep in the joint.

E. Mixing: Joint filler is a two part product requiring machine mixing and placing. Premix part b separately before using. Follow pump manufacturer's equipment instructions.

F. Placement: Joint filler shall be filled full depth. No backer rod is allowed. Joints should be overfilled and shaved even with the surrounding joint edge giving the floor joints a flat, smooth appearance. Shaving of excess joint filler can be approximately 30 minutes after placement, and up to 24 hours later, depending on jobsite conditions such as concrete and ambient temperatures.

G. Joint filler separation: The approved joint filling applicator shall include in their bid a cost per linear foot to make one return trip to refill joints if joint filler sidewall separation or spalling exceeds 1/16;" or if surface profile is concave, chattered or if voids occur. This shall take place one week prior to grand opening.

15) INITIAL CLEANING FOR LIQUID DENSIFER AND SEALER APPLICATION:

A. Interior sales floor slab: Thoroughly clean the interior sales floor slab prior to initial application of liquid densifier and sealer by completely removing the specified dissipating or removable curing compound from the floor surface. The following floor stripper or removal solution shall be applied to the floor to thoroughly strip, clean and remove all curing compound residue:

- 1. If Kurez DR VOX (slab first) was used to cure the slab, use "Euco Clean & Strip" by Euclid Chemical, applied at the proper water to floor stripper ratio and coverage rate that will completely remove the Kurez DR VOX. Contact: Phil Brandt (877) 438-3826

- 2. If Kurez RC (slab last) was used to cure the slab, use "Kurez OFF" by Euclid Chemical, applied at the proper water to floor cleaner ratio and coverage rate that will completely remove the Kurez RC. Contact: Phil Brandt (877) 438-3826

16) POLISHING PROCESS AND APPLICATION OF LIQUID DENSIFER / SEALER:

A. All Applicators must be certified by Euclid Chemical or Retro-Plate.

B. The revised process can be used in both "Wet" and "Dry" applications.

C. This process assumes a quality concrete finish (meets and/or exceeds the specified floor tolerances) by the floor finisher. Failure to achieve the above criteria shall be cause for replacement of the offending segments or grinding/polishing at no cost to the Owner or Tenant.

D. Only the Sales Floor will receive the full 9 step process outlined below under item K.

E. All other areas will only receive steps 1 through 4, no additional work is necessary. The yellow safety striping will remain.

F. The Black painted border will not be required in areas behind fixtures, etc....it will only be installed at the main entry door, office doors, egress doors and doorways into the receiving area and transitions that can be seen by the customers.

G. Steps 2 & 4 are combo steps using different grits of resin bond diamonds on each pass.

H. This is a "Resin" only grind that does not tear away as much of the surface area. The Resin grind will remove a minimal top layer of the concrete surface and should greatly reduce the amount of Waste Product created when compared to the old Metal grind process.

I. If a Cure-n-Seal product is required at the time of slab placement only Water Based Dissipating Sealers are allowed. NO Acrylic Cure-N-Seals are allowed.

J. Prior to application, inspect interior sales floor slab to ensure that slab is clean and free of dust, grease, oils, or other contaminants that might prohibit the proper application and penetration of the liquid densifier and sealer.

K. Process Steps
1. Cut, clean out, prep and fill the concrete floor joints with the Euclid QWIKjoint UVR polyurea joint filler.

2. Grind concrete floor with a combo set of 40/50 grit resin bond diamonds.

3. Grind concrete floor with a combo set of 60/100 grit resin bond diamonds.

4. Thoroughly clean the concrete floor and apply Diamond Hard densifier at 225 square feet per gallon.

5. Polish concrete floor with a combo set of 100/200 grit resin bond diamonds.

6. Polish concrete floor with 400 grit resin bond diamonds.

7. Thoroughly clean concrete floor and then apply Diamond Hard densifier at 700 square feet per gallon.

8. Burnish / Polish concrete floor with 800 grit diamond impregnated pads.

9. Burnish / Polish concrete floor with 1500 Grit Diamond Impregnated pads.

L. All edges must be polished to match concrete floor with coinciding SASE 5" resin Polishing pads or HTC EZ Grind polishing 5" diamond tools.

M. Polish results: Perform polishing process to attain an overall gloss reading of >35 specified overall gloss value (SOGV) as measured using a Horiba IG-320, and a specified minimum gloss reading of >30 minimum local gloss value (MGLV). A minimum of 75 readings shall be taken throughout the interior sales floor. The approved applicator shall take four gloss measurement readings at 90° from each other, and then averaged for one reading at each location. The overall measurement shall be reported to Dollar General within 24 hours of the polishing process. Gloss shall be considered as a quantitative value that expresses the degree of reflection when light hits the concrete floor surface. Gloss measurements will be taken independent of ambient lighting and will be taken within a sealed measurement window located beneath the test unit.

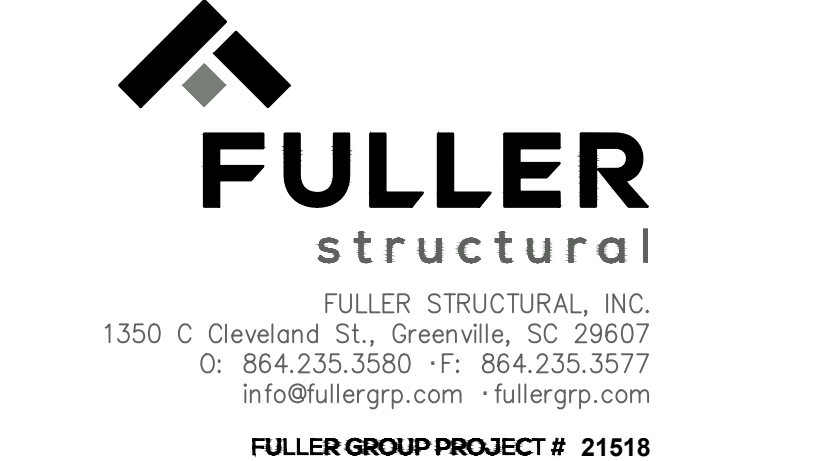

JOHN P. WATKINS, ARCHITECT
56 HILLMARK DRIVE
COLUMBIA, SOUTH CAROLINA 29210

Craig A. Otto
ARCHITECT, INC.

DESIGN • PLANNING • ARCHITECTURE

5044 Augusta Road
Lexington, South Carolina 29072
Phone (803) 957-9004
Fax (803) 957-2050

Table with 3 columns: No., Revisions, Date. Row 0: Issued For Permit, 12/08/21

All rights reserved. This drawing and the design shown thereon are copyrighted as prescribed by the laws of the United States and are the sole property of Craig A. Otto, Architect, Inc. Anyone duplicating, reproducing, or causing to be reproduced these drawings or the design thereon without permission of the architect will be subject to legal action.

Project Title
DOLLAR GENERAL #23725
US 421 S, LILLINGTON, NC

Drawing Title
GENERAL NOTES & SPECIFICATIONS

Consultant

Seal section containing a circular professional seal for Craig A. Otto, P.E., S.E., A.S. G. and a date stamp 'Date DECEMBER 8, 2021' and a drawing number '50.1'.

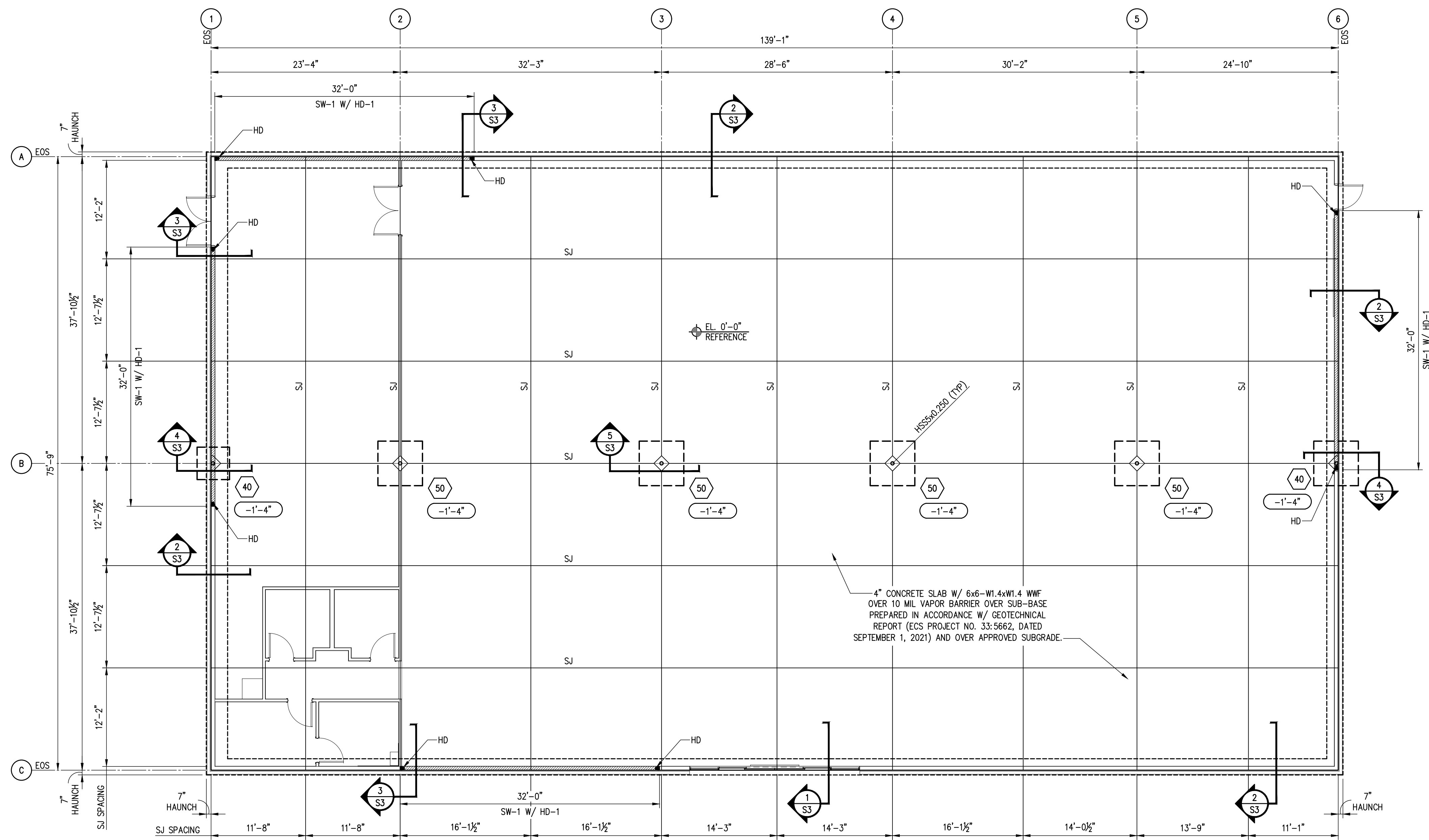

**1 FOUNDATION/SLAB PLAN**  
SCALE: 1/8"=1'-0"

- LEGEND**
- XX FOOTING TYPE - SEE SCHEDULE
  - XX'-XX" TOP OF FOOTING ELEVATION
  - SJ SLAB JOINT - SEE A/S3
  - EOS EDGE OF PRIMARY SLAB - SEE SECTIONS FOR ADDITIONAL INFORMATION
  - XX DENOTES STEEL COLUMN
  - SW-X SHEAR WALL - SEE SCHEDULE
  - HD-X SHEAR WALL HOLDOWN - SEE SCHEDULE

**FOOTING SCHEDULE**

TYPE	SIZE	THICKNESS	REINFORCING
40	4'-0"x4'-0"	1'-6"	(5) #5 EACH WAY
50	5'-0"x5'-0"	1'-6"	(6) #5 EACH WAY

**SHEAR WALL SCHEDULE**

TYPE	SHEATHING	NAILS	SPACING	
			EDGE	INT.
SW-1	3/8" WOOD SHEATHING	8d	6"	12"

- NOTES:**
- FRAMING FOR SHEAR WALLS TO BE 2x6 STUDS SPACED AT 16" O.C.
  - PROVIDE 3/8" TITEN HD SCREW ANCHORS @ 24" O.C. W/ 7" EMBEDMENT.
  - SEE NOTES FOR SHEATHING SPECS.
  - BLOCK ALL PANEL EDGES.

**HOLDOWN SCHEDULE**

TYPE	SIMPSON HOLDOWN	ANCHOR	END WALL STUDS
HD1	HDU-4	3/8" THREADED ROD (12" EMBEDMENT) IN ANCHORING ADHESIVE	(2) 2x6

- NOTES:**
- AT INTERSECTING SHEARWALL CORNERS WHERE MULTIPLE OF THE SAME HOLD DOWNS ARE SPECIFIED, ONE HOLD DOWN MAY BE OMITTED. HOLD DOWN SHALL BE CONNECTED TO THE CORNER COLUMN.
  - AT INTERSECTING SHEARWALL CORNERS WHERE MULTIPLE DIFFERENT HOLD DOWNS ARE SPECIFIED, THE WEAKER HOLD DOWN MAY BE OMITTED. HOLD DOWN SHALL BE CONNECTED TO CORNER COLUMN.

- FOUNDATION PLAN NOTES:**
- SEE SHEET S0 FOR GENERAL NOTES & DESIGN CRITERIA.
  - CONFIRM ALL DIMENSIONS W/ ARCHITECTURAL DRAWINGS. REPORT DISCREPANCIES PRIOR TO CONSTRUCTION.
  - REFER TO ARCHITECTURAL, MECHANICAL, ELECTRICAL, PLUMBING, AND DRAWINGS OF OTHER DISCIPLINES FOR LOCATIONS AND DIMENSIONS OF OPENING, DEPRESSION, AND OTHER NON-STRUCTURAL ITEMS.
  - ELEVATIONS GIVEN ARE FROM REFERENCE ELEVATION. REFERENCE ELEVATION (+0'-0") IS SET AT FINISH FLOOR ELEV. SEE CIVIL DRAWINGS FOR ADDITIONAL INFORMATION.
  - TYP. SLAB-ON-GRADE IS 4" NORMAL WEIGHT CONCRETE REINFORCED W/ (1) LAYER 6x6WI.4xWI.4 WWF OVER 15 MIL VAPOR BARRIER OVER SUBBASE.
  - PROVIDE (2) #3x3'-0" LONG IN TOP OF SLAB @ ALL RE-ENTRANT CORNERS NOT INTERSECTING A SLAB JOINT.

**NOTE:**  
CIVIL DRAWINGS WERE NOT PROVIDED AT TIME OF DEVELOPMENT OF THESE CONSTRUCTION DOCUMENTS. DOCUMENTS HAVE BEEN DESIGNED AS IF THE SITE IS FLAT. CIVIL DRAWINGS SHALL BE SUBMITTED PRIOR TO BEGINNING CONSTRUCTION TO THE ENGINEER OR RECORD.

**FULLER**  
structural

FULLER STRUCTURAL, INC.  
1350 C Cleveland St., Greenville, SC 29607  
O: 864.235.3580 F: 864.235.3577  
info@fullergrp.com -fullergrp.com  
FULLER GROUP PROJECT # 21518

**JOHN P. WATKINS, ARCHITECT**  
56 HILLMARK DRIVE  
COLUMBIA, SOUTH CAROLINA 29210

**Craig A. Otto**  
ARCHITECT, INC.

DESIGN • PLANNING • ARCHITECTURE

5044 Augusta Road  
Lexington, South Carolina 29072  
Phone (803) 957-9004  
Fax (803) 957-2050

No.	Revisions	Date
0	Issued For Permit	12/08/21

All rights reserved. This drawing and the design shown thereon are copyrighted as prescribed by the laws of the United States and are the sole property of Craig A. Otto, Architect, Inc. Anyone duplicating, reproducing, or causing to be reproduced these drawings or the design thereon without permission of the architect will be subject to legal action.

Project Title **DOLLAR GENERAL #23725**  
US 421 S, LILLINGTON, NC

Drawing Title **FOUNDATION/SLAB PLAN**

Consultant

Seal

Date **DECEMBER 8, 2021**  
Drawn By **SJF**  
Drawing No. **S1**

- ROOF FRAMING PLAN NOTES**
- SEE SHEET S0 FOR GENERAL NOTES & DESIGN CRITERIA.
  - TRUSS BEARING ELEVATION SHALL BE +14'-0" AT ROOF LEVEL U.N.O. ELEVATIONS GIVEN ARE FROM REFERENCE ELEVATION. REFERENCE ELEVATION (+0'-0") IS SET AT LEVEL 1 FINISHED FLOOR ELEV. SEE CIVIL DRAWINGS.
  - SHADED WALLS ARE STRUCTURAL BEARING AND/OR SHEAR WALLS. DO NOT BEAR TRUSSES ON NON-STRUCTURAL WALLS.
  - POSTS SHOWN ON PLAN ARE TO BE CENTERED ON WALL STUD CENTERLINE, U.N.O.
  - WHERE SHOWN, RTU LOCATIONS ARE APPROXIMATE AND SHALL BE COORDINATED W/ MECH. DRAWINGS. WEIGHTS & LOCATIONS SHOWN ARE BASED ON THE LATEST MECHANICAL INFORMATION AT TIME OF SUBMITTAL. REPORT ANY DISCREPANCIES TO ARCHITECT AND ENGINEER FOR REVIEW PRIOR TO CONSTRUCTION.
  - REFER TO ARCHITECTURAL, MECHANICAL, ELECTRICAL, PLUMBING, AND DRAWINGS OF OTHER DISCIPLINES FOR LOCATIONS, DIMENSIONS OF OPENINGS, AND OTHER NONSTRUCTURAL ITEMS.
  - U.N.O. CANOPY FRAMING & ATTACHMENT IS BY OTHERS. SEE ARCHITECTURAL FOR ADDITIONAL INFORMATION.
  - TYPICAL ROOF SHEATHING IS 5/8" THICK PLYWOOD OR OSB.
  - TRUSSES ARE EQUALLY SPACED ALONG SUPPORTING MEMBERS UNLESS NOTED OTHERWISE.
  - TRUSS BRACING
    - ERECTION BRACING SHALL BE INSTALLED AS NECESSARY TO HOLD THE TRUSSES TRUE AND PLUMB AND IN A SAFE CONDITION UNTIL PERMANENT TRUSS BRACING AND BRIDGING IS INSTALLED. TEMPORARY BRACING SHALL BE CONSIDERED IN THE INSTALLER'S MEANS AND METHODS.
    - TRUSS BRACING AND BRIDGING SHALL BE DESIGNED BY THE TRUSS ENGINEER AND SUBMITTED TO THE ENGINEER OF RECORD FOR THE REVIEW ON SHOP DRAWING SUBMITTALS. SUBMITTALS SHALL INCLUDE ALL ITEMS ON THE LIST PROVIDED BY ANS/TP-1 UNDER "INFORMATION ON TRUSS DESIGN DRAWINGS."
    - ALL TEMPORARY AND PERMANENT BRACING SHALL BE INSTALLED AND ALL COMPONENTS FASTENED BEFORE THE APPLICATION OF ANY LOAD TO THE TRUSSES.

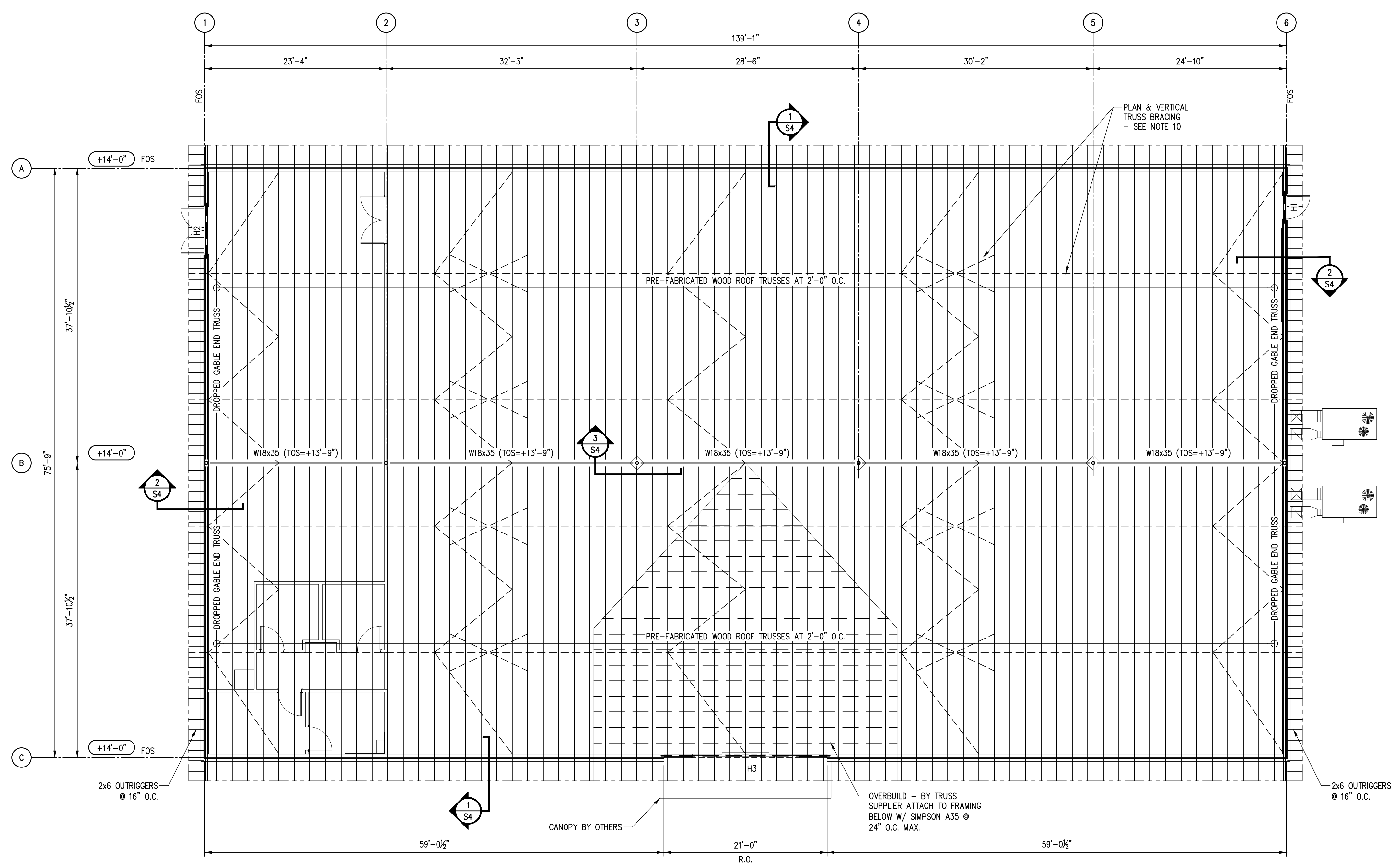

**1 ROOF FRAMING PLAN**  
 SCALE: 1/8"=1'-0"

LEGEND  
 +XX'-XX" TRUSS BEARING ELEVATION ABOVE FINISHED FLOOR

**WOOD HEADER SCHEDULE FOR EXTERIOR WALLS**

HEADER MARK	HEADER BEAM SIZE	NO. OF JACK STUDS @ EACH END U.N.O.	NO. OF KING STUDS @ EACH END U.N.O.
H1	(3) 2x6 SPF W/ (2) 1/2" PLYWOOD SPACERS	(2) 2x6	(1) 2x6
H2	(3) 2x10 SPF W/ (2) 1/2" PLYWOOD SPACERS	(2) 2x6	(2) 2x6
H3	(3) 1.75"x18" LVL W/ (1) 1/2" PLYWOOD SPACERS	(2) 2x6	(3) 2x6

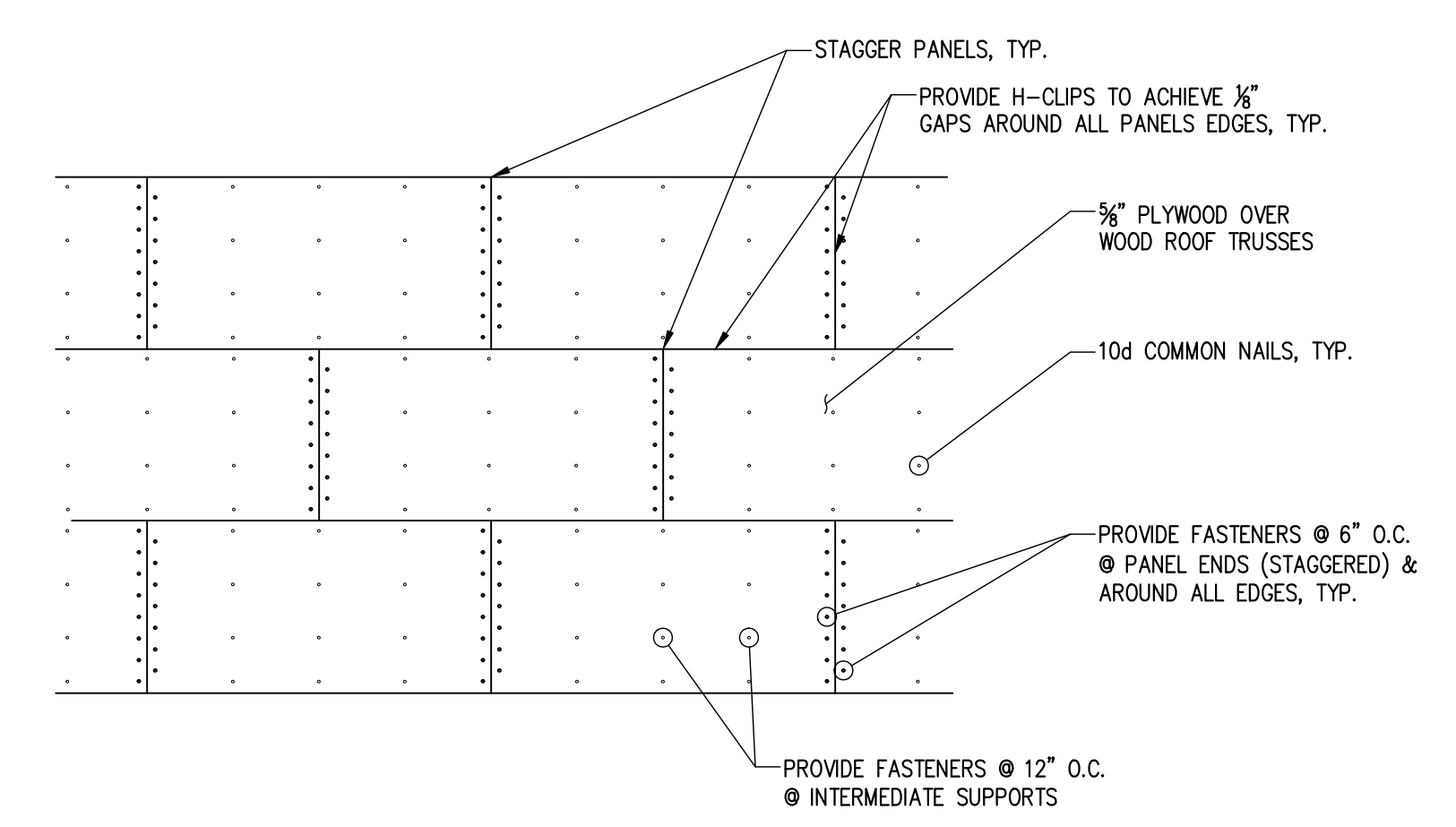

**A TYP. ROOF SHEATHING**  
 SCALE: N.T.S.

**JOHN P. WATKINS, ARCHITECT**  
 56 HILLMARK DRIVE  
 COLUMBIA, SOUTH CAROLINA 29210

**Craig A. Otto**  
 ARCHITECT, INC.

DESIGN • PLANNING • ARCHITECTURE

5044 Augusta Road  
 Lexington, South Carolina 29072  
 Phone (803) 957-9004  
 Fax (803) 957-2050

No.	Revisions	Date
0	Issued For Permit	12/08/21

All rights reserved. This drawing and the design shown thereon are copyrighted as prescribed by the laws of the United States and are the sole property of Craig A. Otto, Architect, Inc. Anyone duplicating, reproducing, or causing to be reproduced these drawings or the design thereon without permission of the architect will be subject to legal action.

Project Title **DOLLAR GENERAL #23725**  
 US 421 S, LILLINGTON, NC

Drawing Title **ROOF FRAMING PLAN**

Consultant

Seal:

Date: **DECEMBER 8, 2021**  
 Drawn By: **SJF**  
 Drawing No.: **S2**

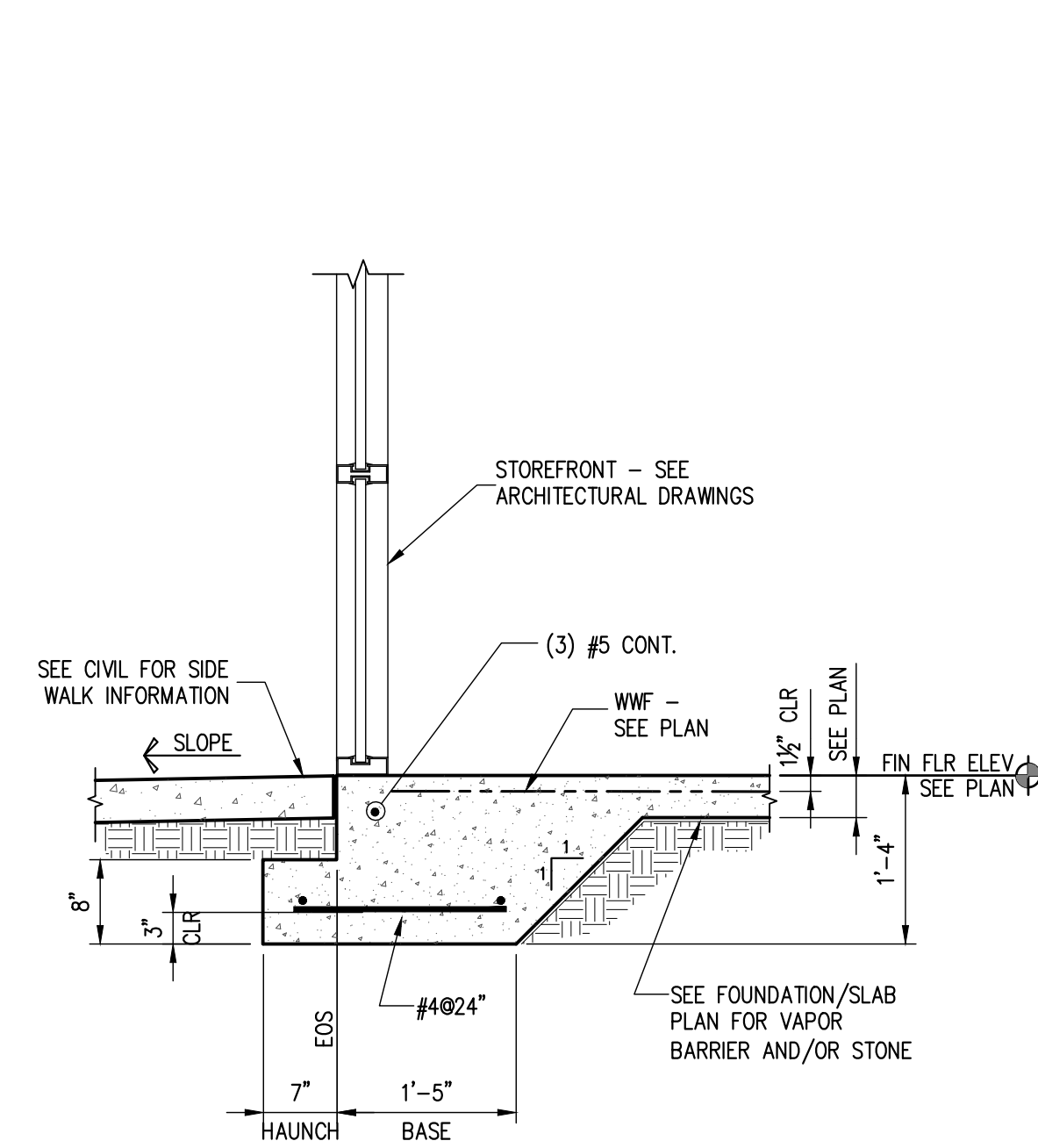

**SECTION 1**  
S3 SCALE: 3/4"=1'-0"

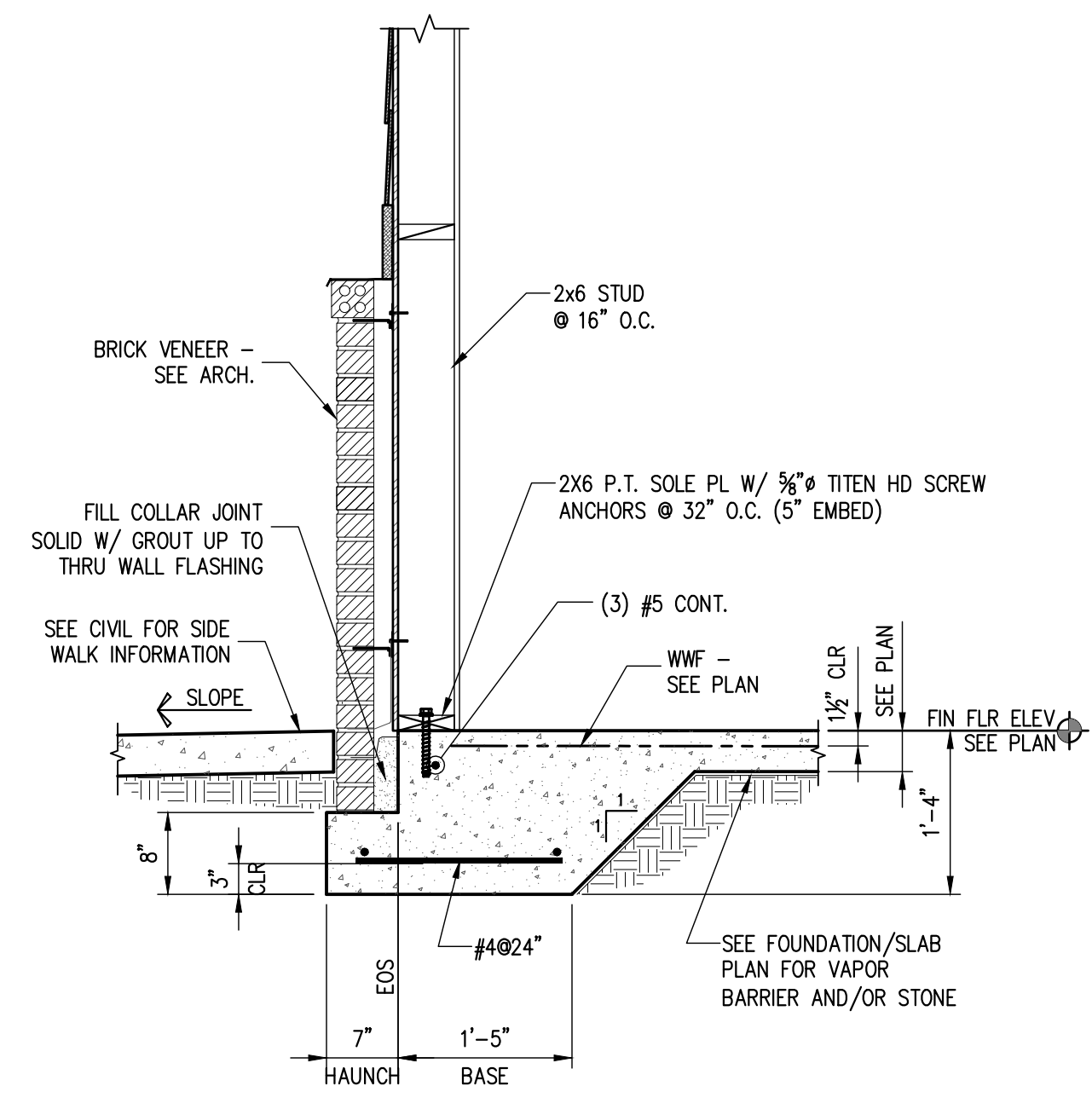

**SECTION 2**  
S3 SCALE: 3/4"=1'-0"

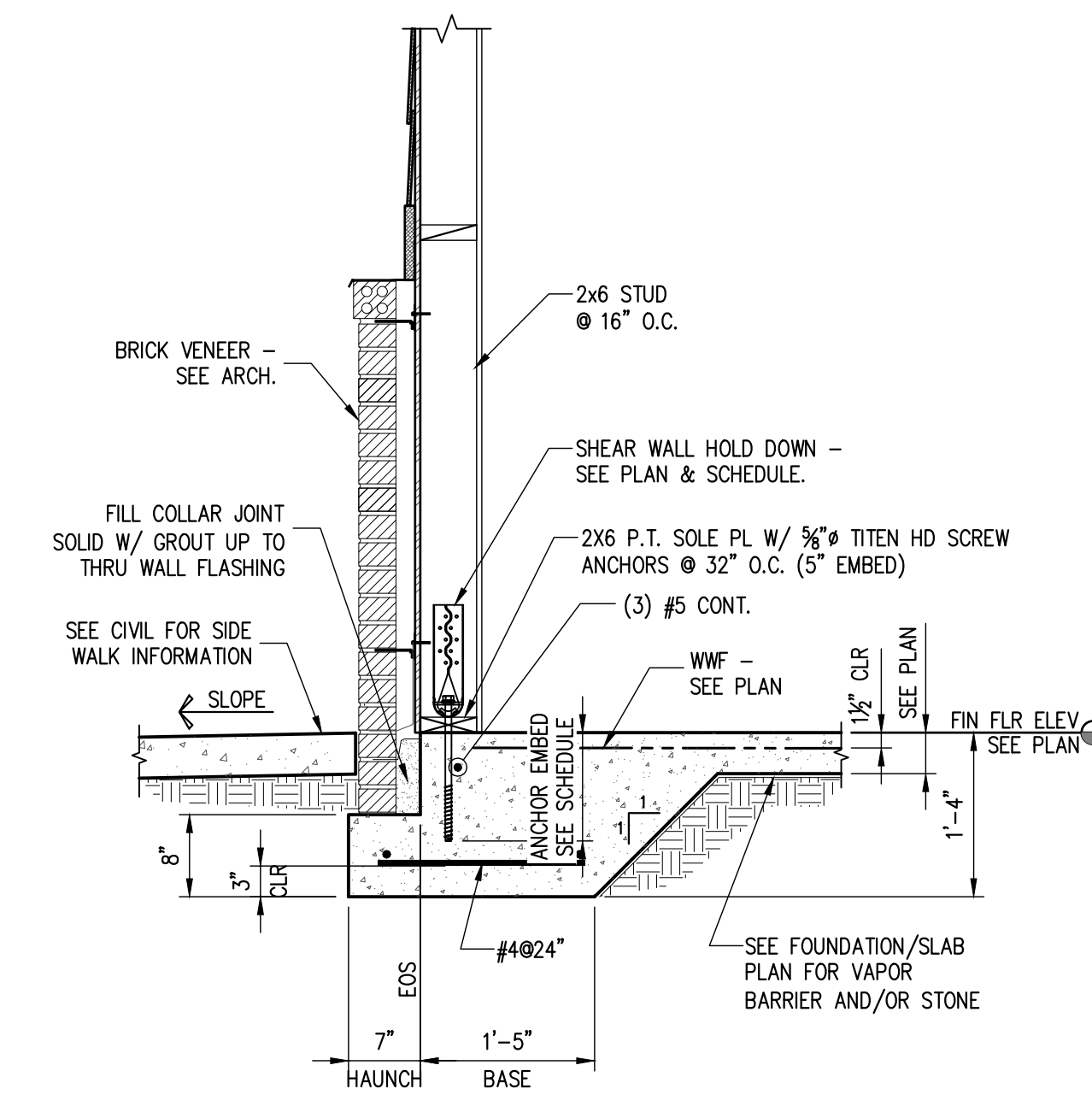

**SECTION 3**  
S3 SCALE: 3/4"=1'-0"

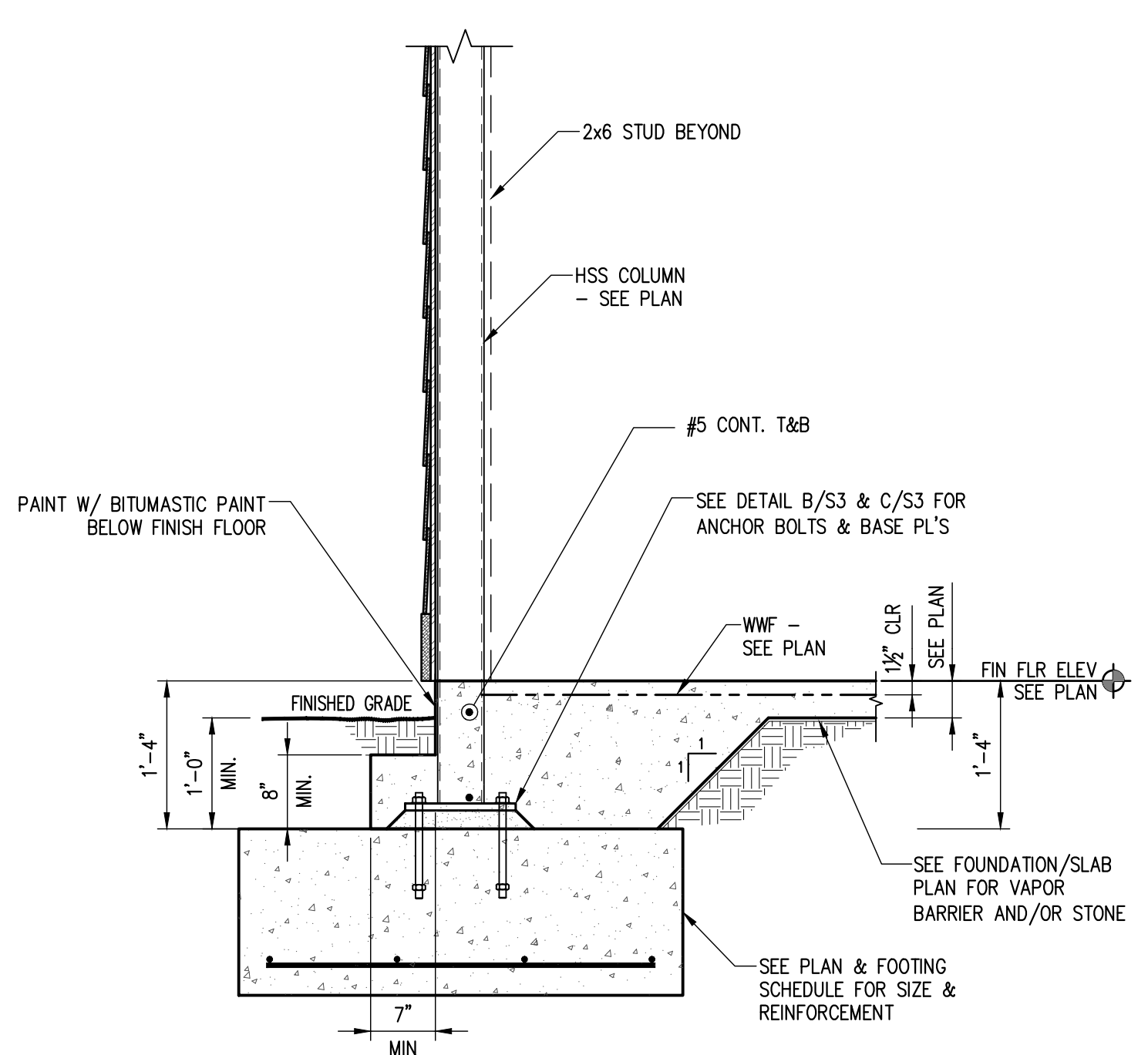

**SECTION 4**  
S3 SCALE: 3/4"=1'-0"

See Detail 1/3 on A5.1 for slab insulation details

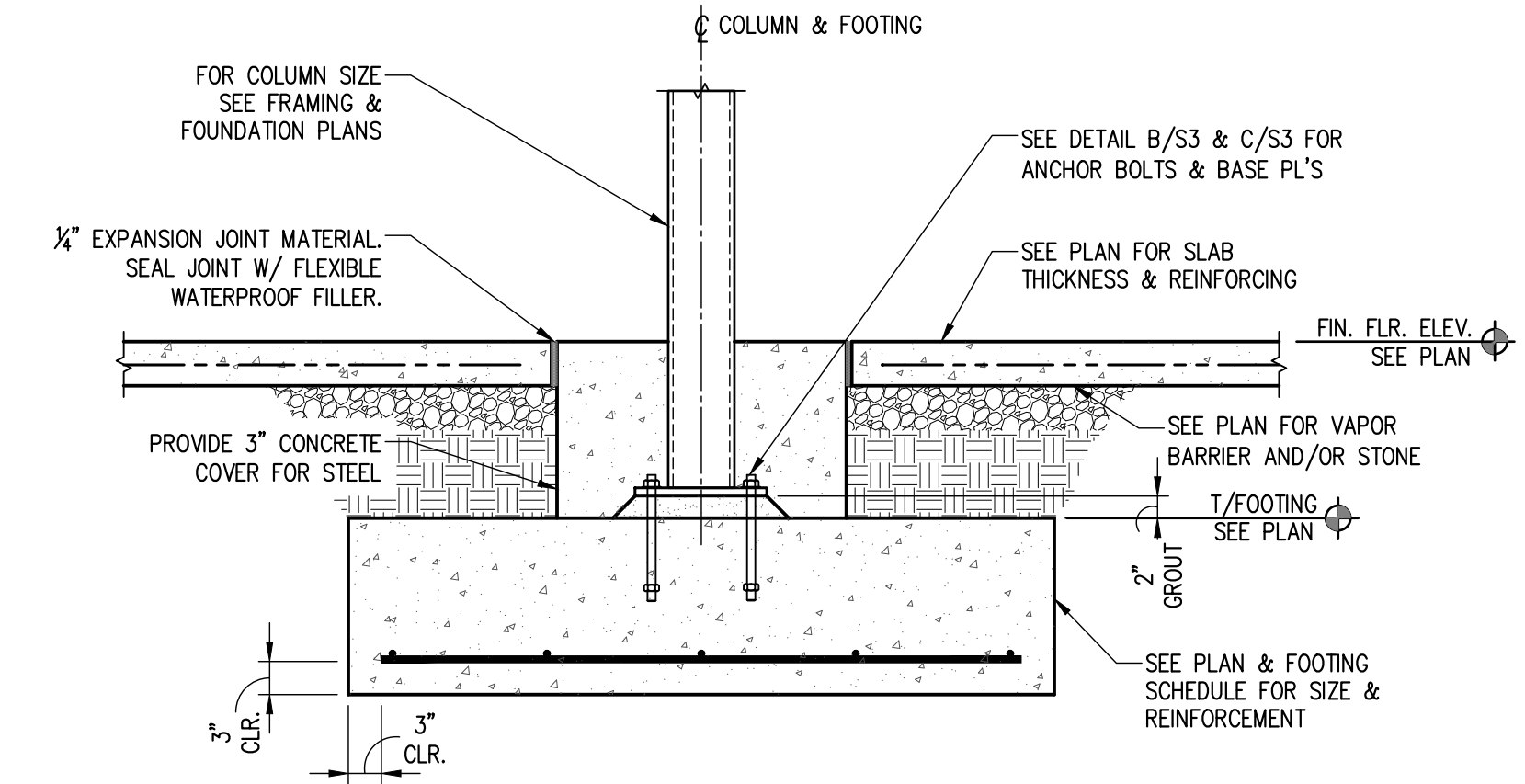

**SECTION 5**  
S3 SCALE: 3/4"=1'-0"

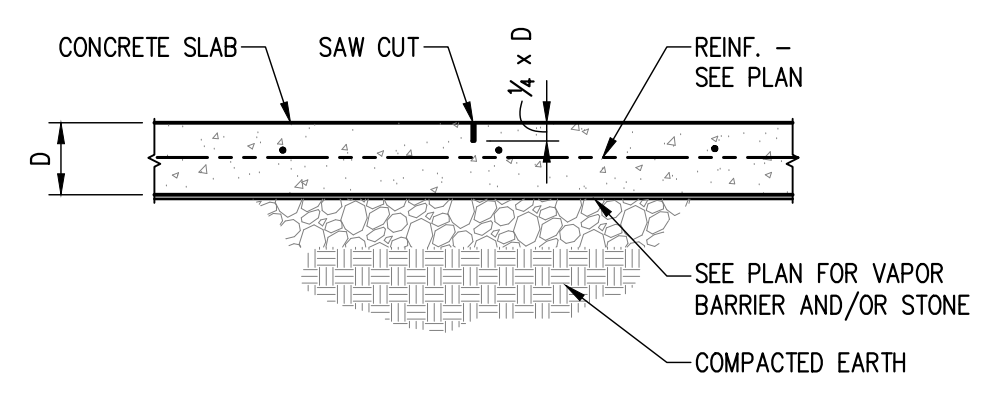

TYPICAL SAWN JOINT

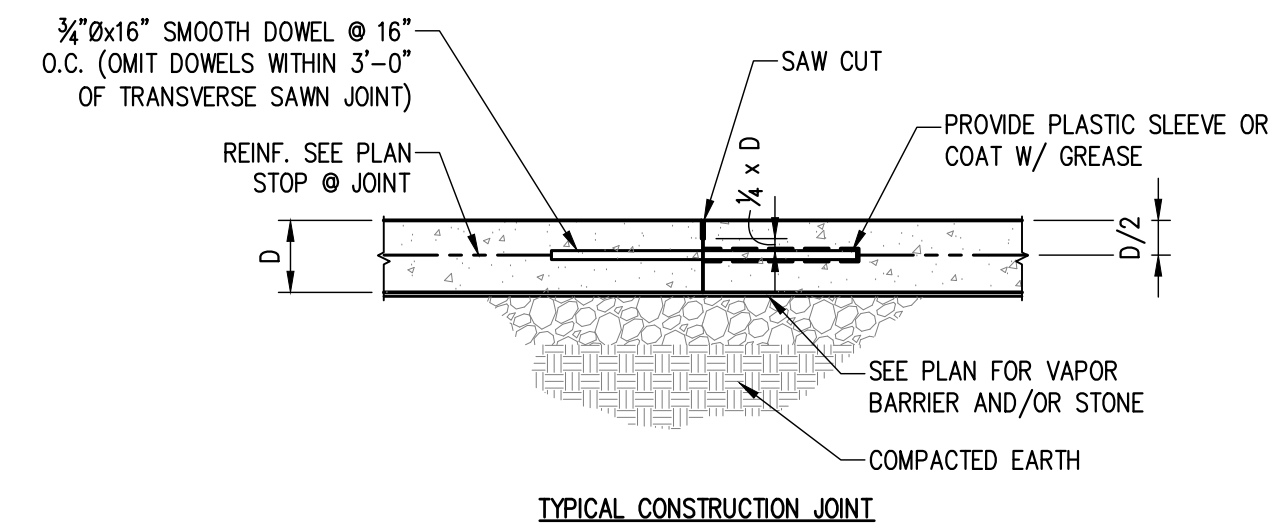

TYPICAL CONSTRUCTION JOINT

**A TYPICAL SLAB JOINT DETAILS**  
S3 NTS

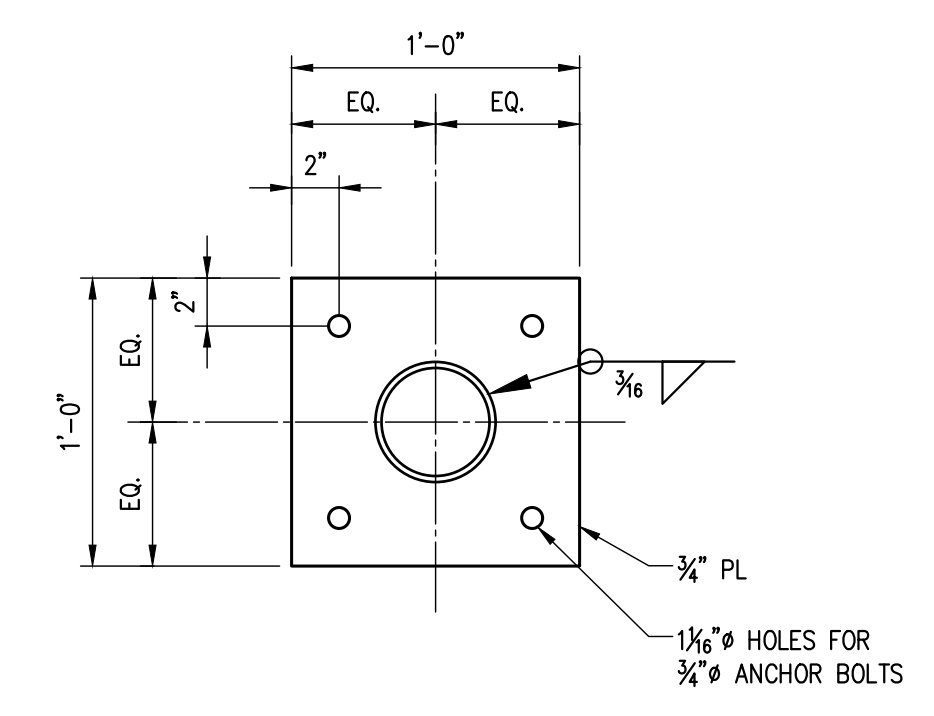

**B BASE PL DETAIL**  
S3 SCALE: 1 1/2"=1'-0"

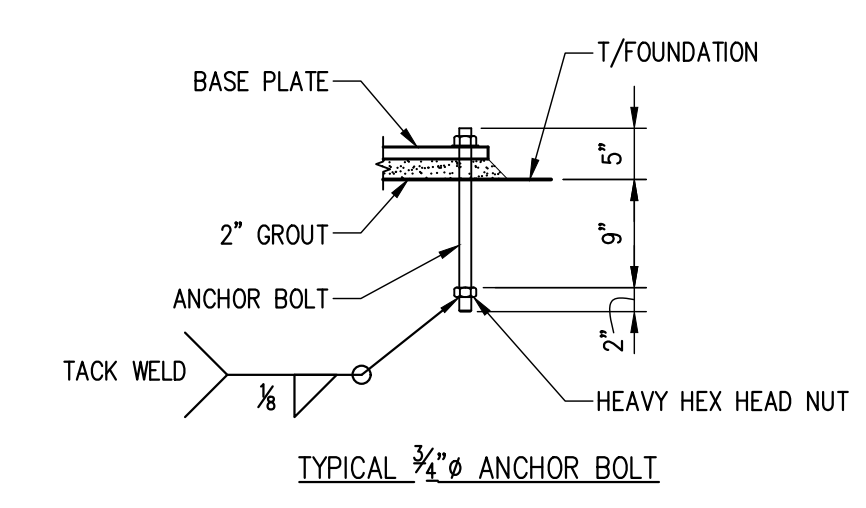

**C SECTION**  
S3 SCALE: 3/4"=1'-0"

**FULLER**  
structural

FULLER STRUCTURAL, INC.  
1350 C Cleveland St., Greenville, SC 29607  
O: 864.235.3580 F: 864.235.3577  
info@fullergrp.com fullergrp.com

FULLER GROUP PROJECT # 21518

**JOHN P. WATKINS, ARCHITECT**  
56 HILLMARK DRIVE  
COLUMBIA, SOUTH CAROLINA 29210

Craig A. Otto  
ARCHITECT, INC.

DESIGN • PLANNING • ARCHITECTURE

5044 Augusta Road  
Lexington, South Carolina 29072  
Phone (803) 957-9004  
Fax (803) 957-2050

No.	Revisions	Date
0	Issued For Permit	12/08/21

All rights reserved. This drawing and the design shown thereon are copyrighted as prescribed by the laws of the United States and are the sole property of Craig A. Otto, Architect, Inc. Anyone duplicating, reproducing, or causing to be reproduced these drawings or the design thereon without permission of the architect will be subject to legal action.

Project Title **DOLLAR GENERAL #23725**  
**US 421 S, LILLINGTON, NC**

Drawing Title  
**FOUNDATION SECTIONS AND DETAILS**

Consultant

<p>Seal</p>	<p>Date <b>DECEMBER 8, 2021</b></p> <p>Drawn By <b>SJF</b></p> <p>Drawing No. <b>S3</b></p>
-------------	---

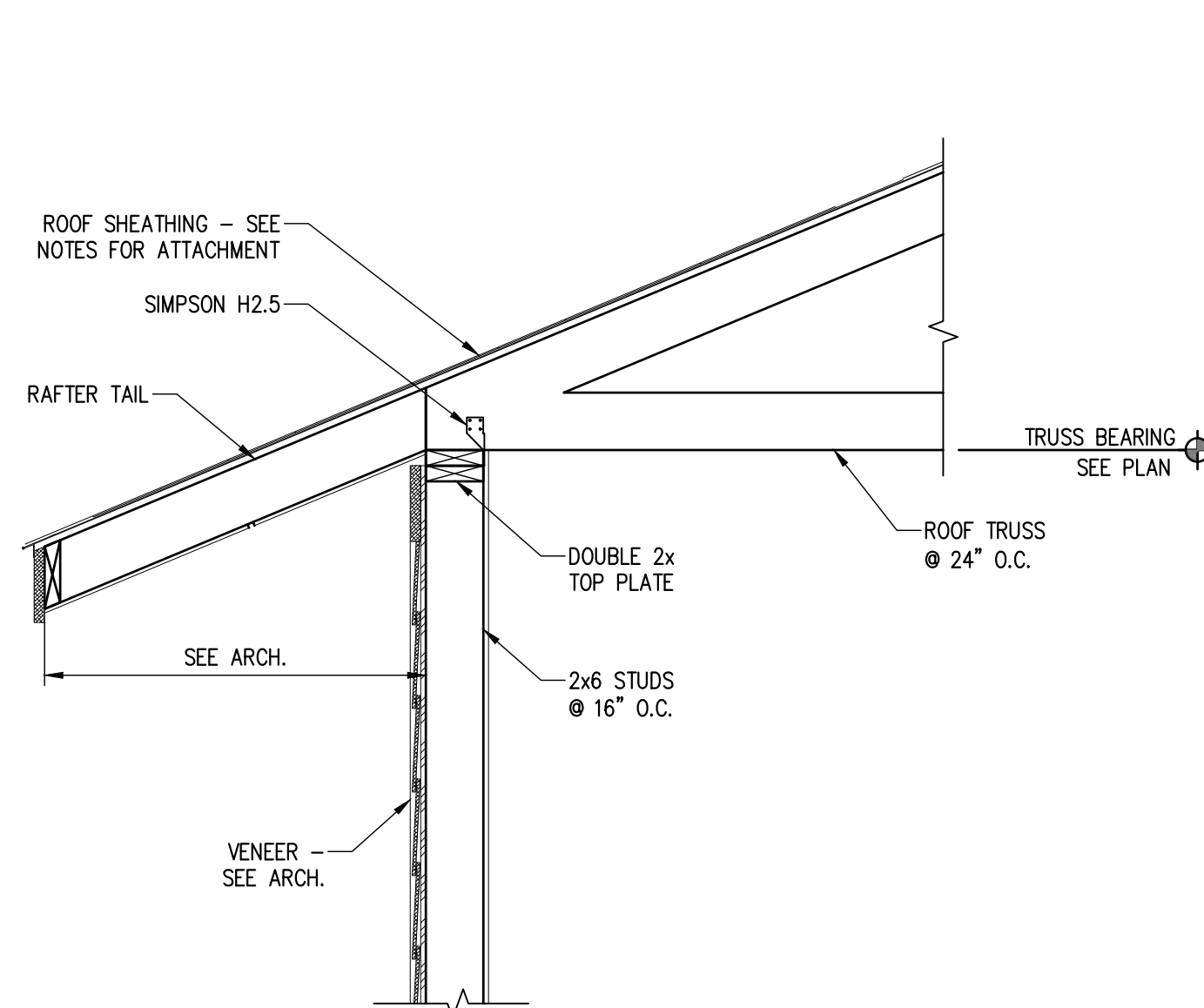

**1 SECTION**  
S4 SCALE: N.T.S.

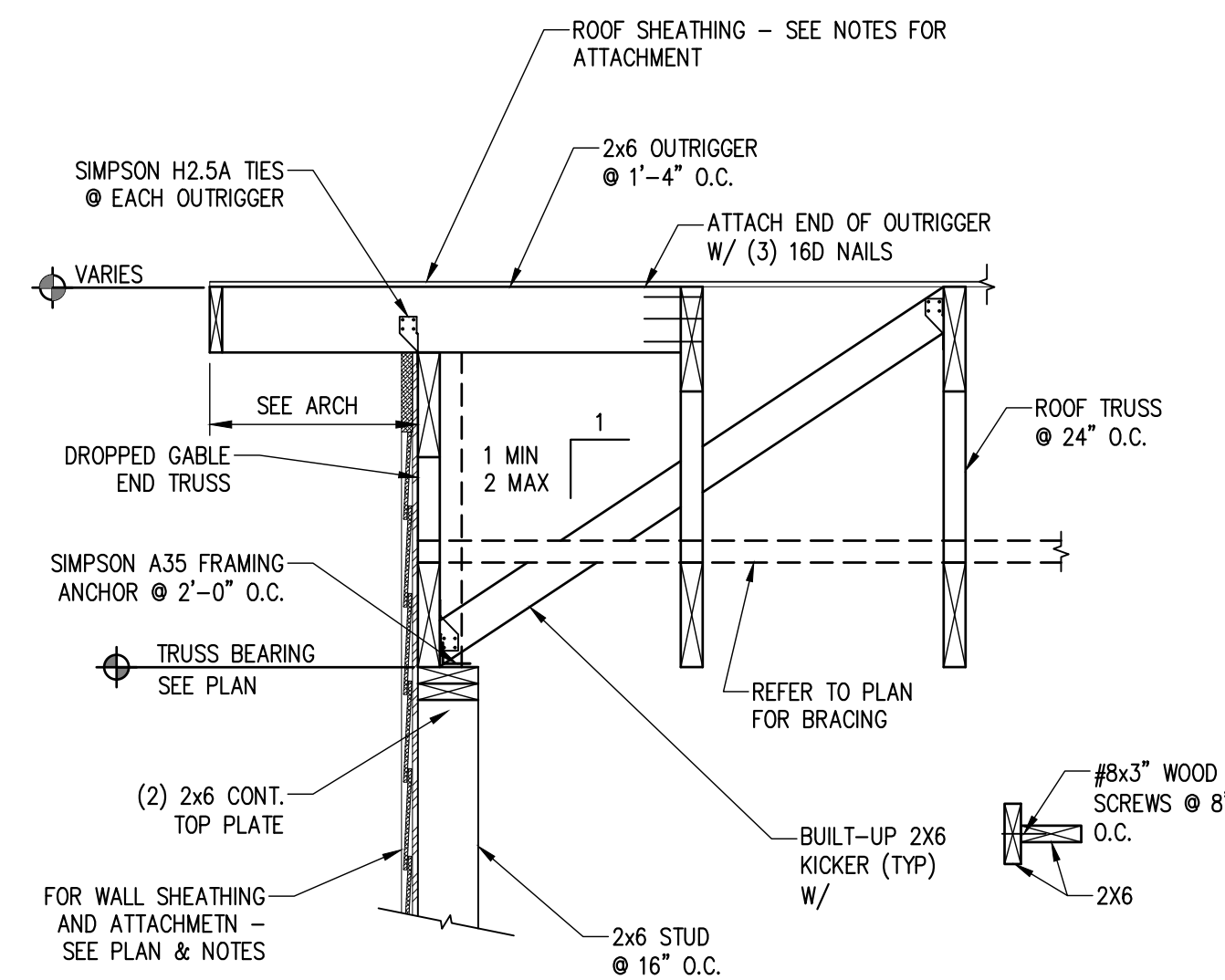

**2 SECTION**  
S4 SCALE: N.T.S.

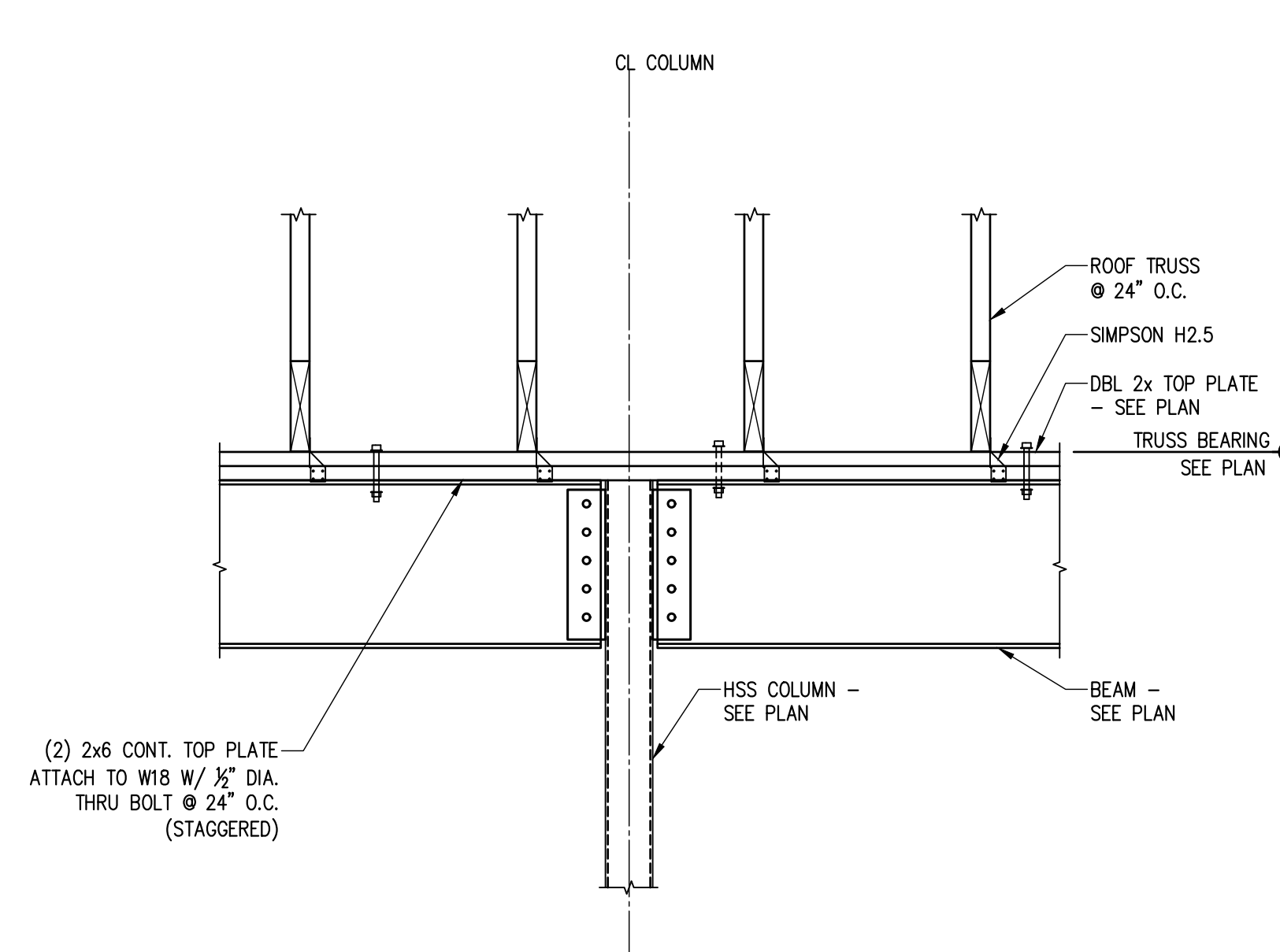

**3 SECTION**  
S4 SCALE: N.T.S.

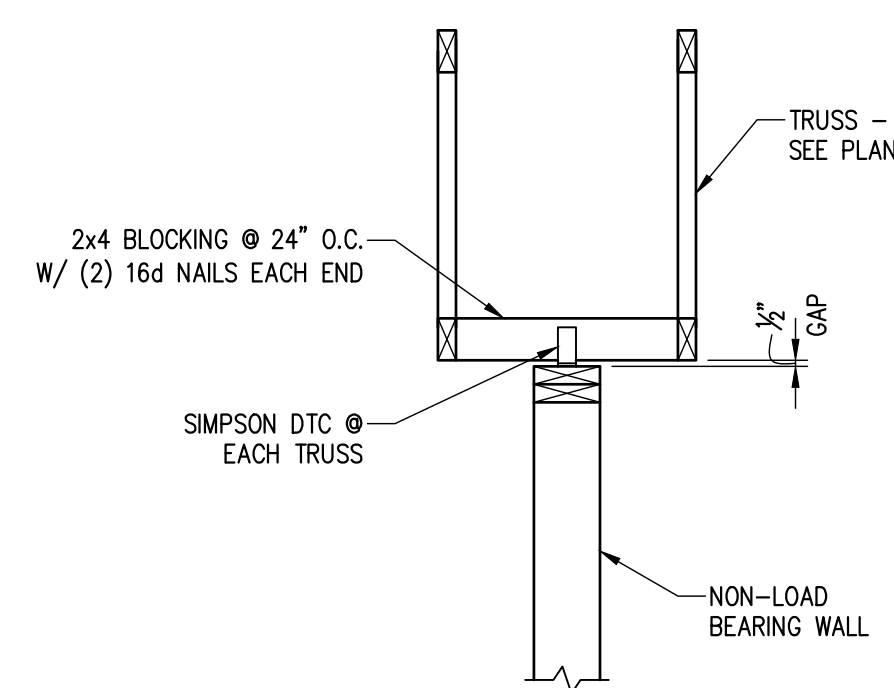

**TYP. INTERIOR PARTITION WALL PARALLEL TRUSS**  
A S4 SCALE: N.T.S.

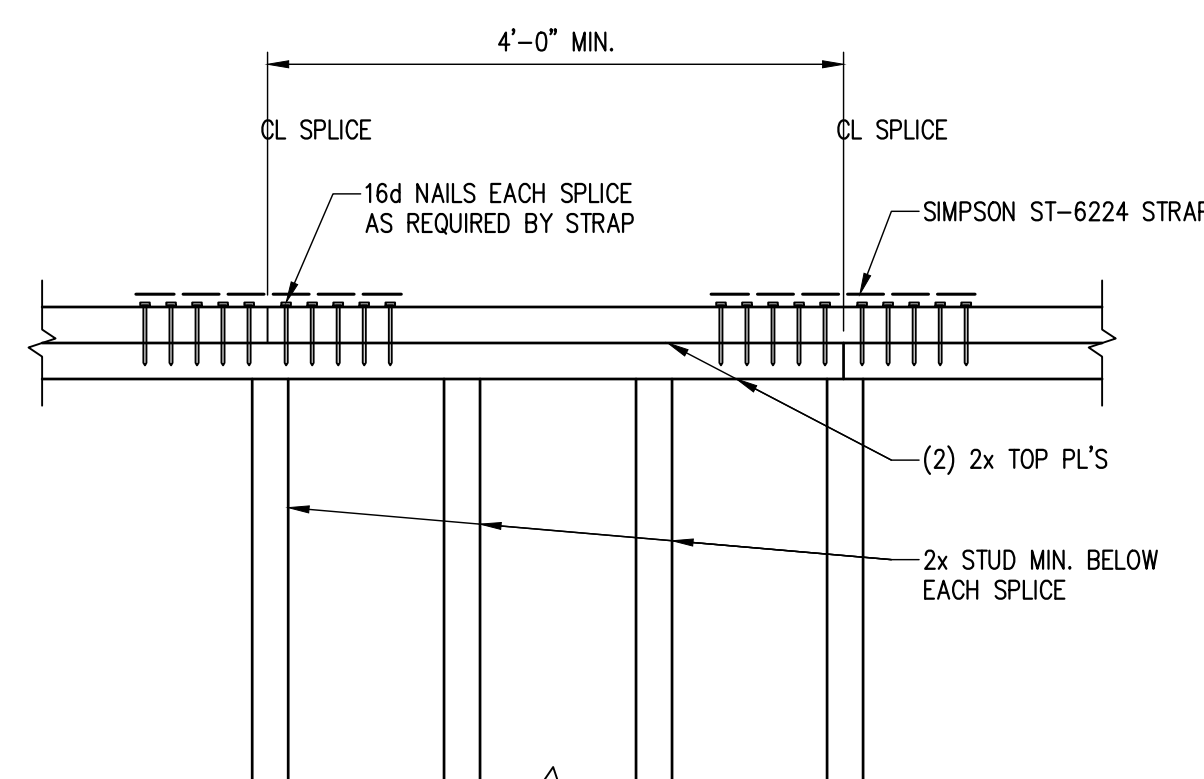

**B TOP PLATE SPLICE**  
S4 SCALE: N.T.S.

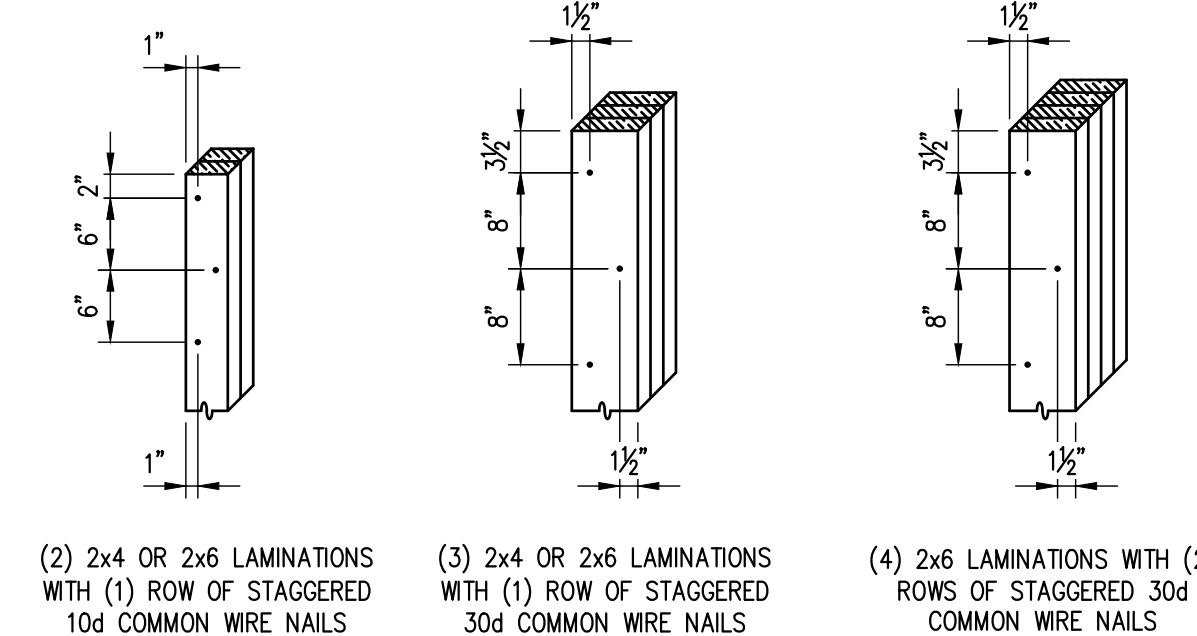

**C BUILT UP POST DETAIL**  
S4 SCALE: N.T.S.

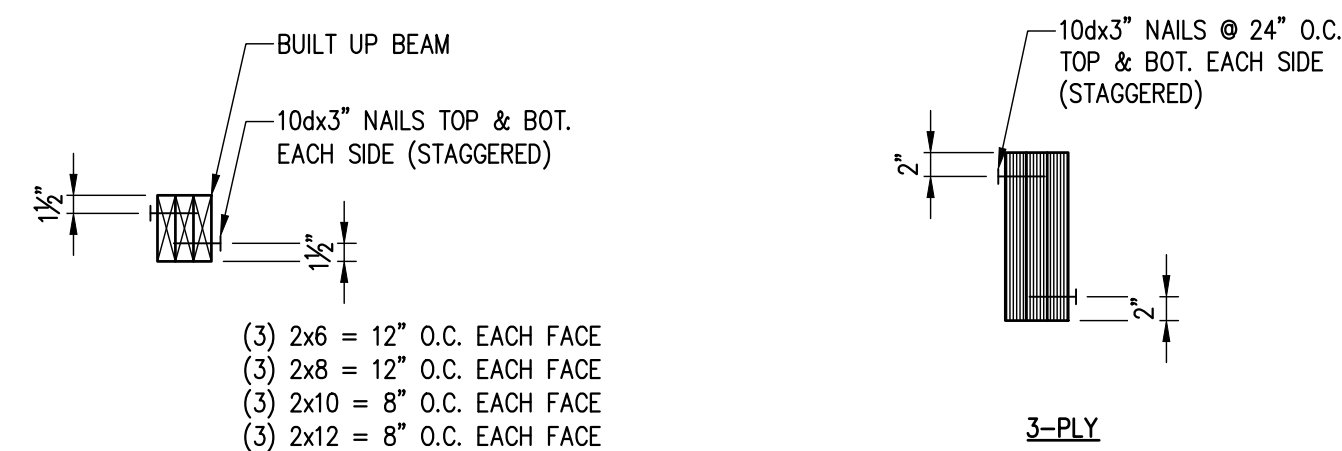

**D TYP. BUILT-UP BEAM NAILING**  
S4 SCALE: N.T.S.

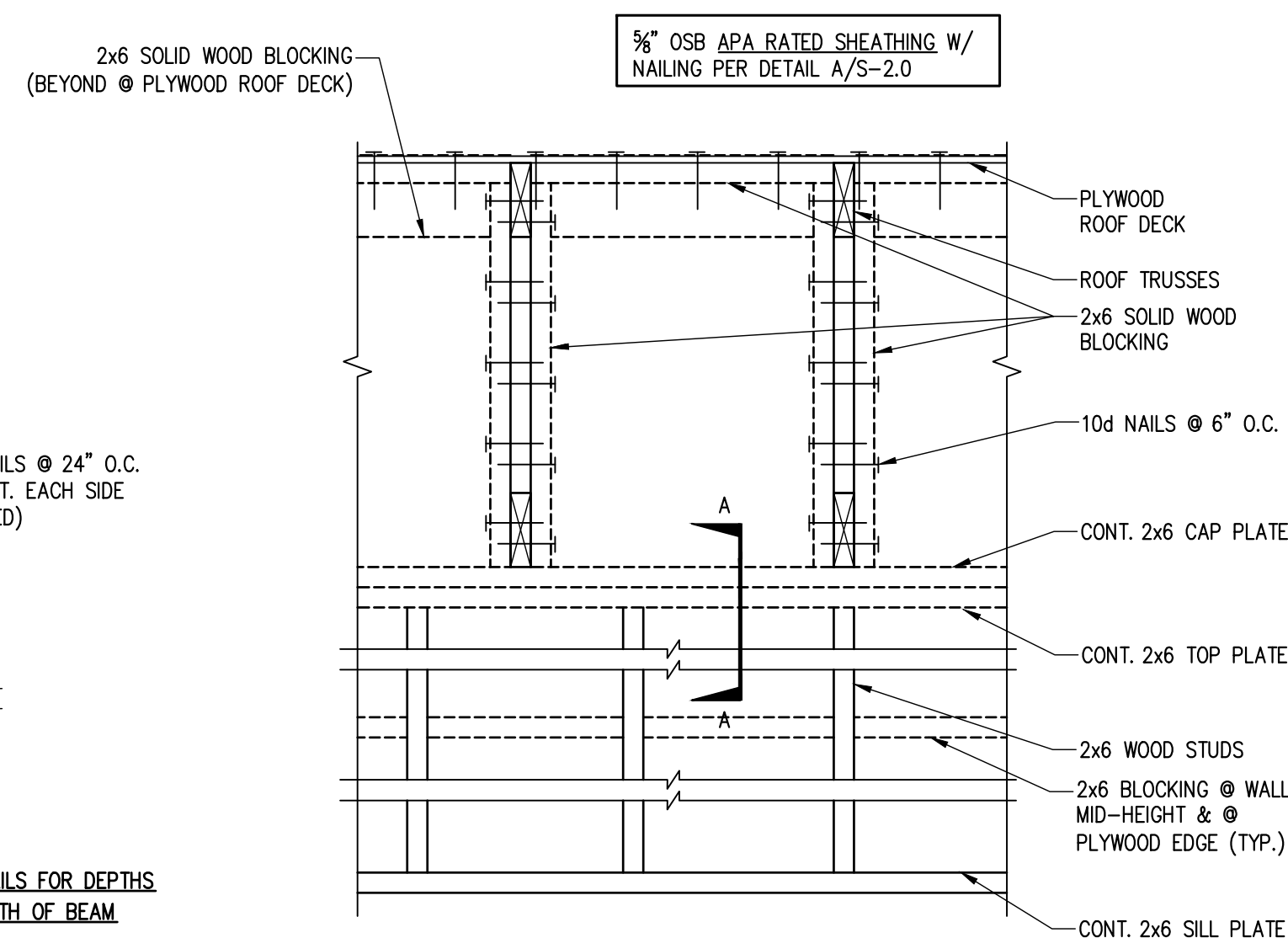

**E SHEAR WALL ELEVATION**  
S4 SCALE: N.T.S.

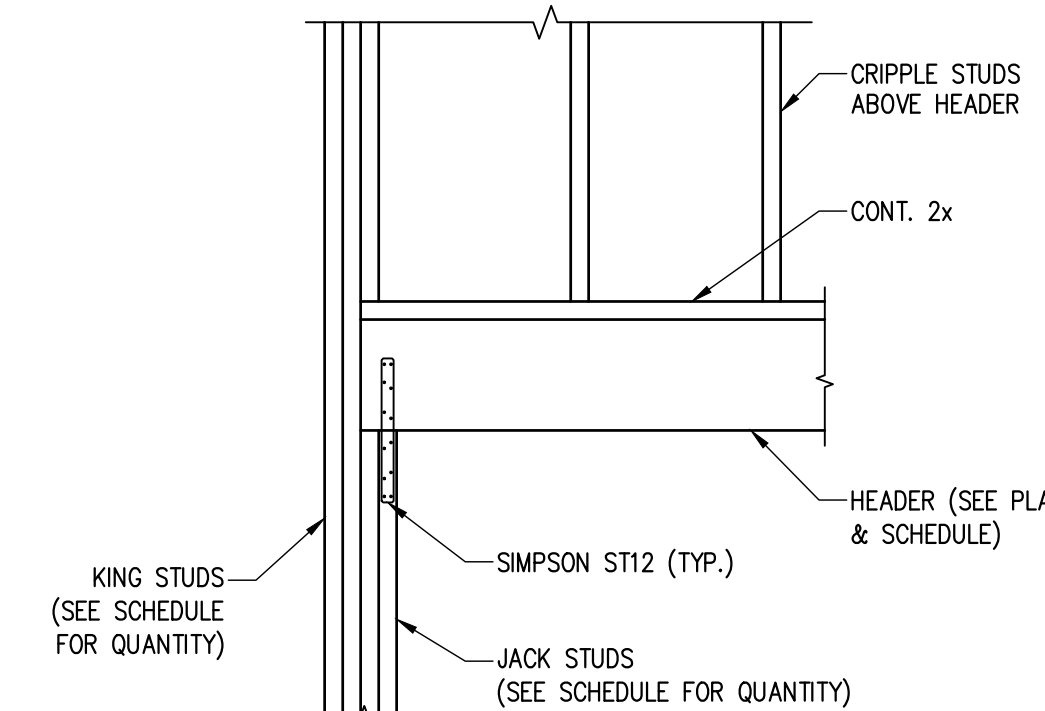
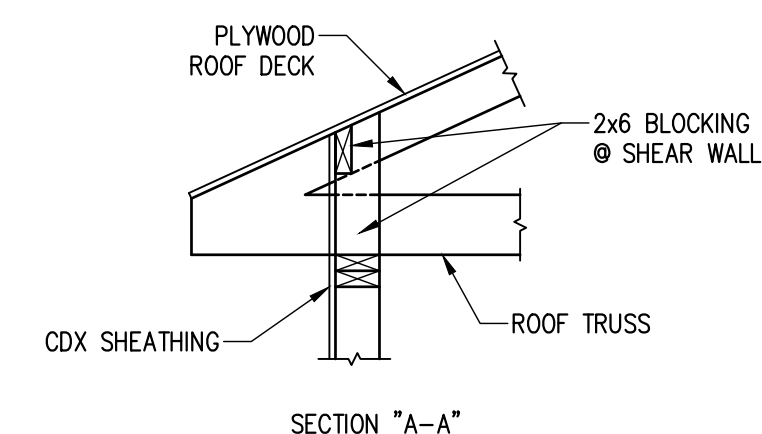

**F DETAIL**  
S4 SCALE: N.T.S.

**FULLER**  
structural  
FULLER STRUCTURAL, INC.  
1350 C Cleveland St., Greenville, SC 29607  
O: 864.235.3580 F: 864.235.3577  
info@fullergrp.com fullergrp.com  
FULLER GROUP PROJECT # 21518

JOHN P. WATKINS, ARCHITECT  
56 HILLMARK DRIVE  
COLUMBIA, SOUTH CAROLINA 29210

**Craig A. Otto**  
ARCHITECT, INC.

DESIGN • PLANNING • ARCHITECTURE

5044 Augusta Road  
Lexington, South Carolina 29072  
Phone (803) 957-9004  
Fax (803) 957-2050

No.	Revisions	Date
0	Issued For Permit	12/08/21

All rights reserved. This drawing and the design shown thereon are copyrighted as prescribed by the laws of the United States and are the sole property of Craig A. Otto, Architect, Inc. Anyone duplicating, reproducing, or causing to be reproduced these drawings or the design thereon without permission of the architect will be subject to legal action.

Project Title **DOLLAR GENERAL #23725**  
**US 421 S, LILLINGTON, NC**

Drawing Title **FRAMING SECTIONS AND DETAILS**

Consultant

Seal  
Date **DECEMBER 8, 2021**  
Drawn By **SJF**  
Drawing No. **S4**

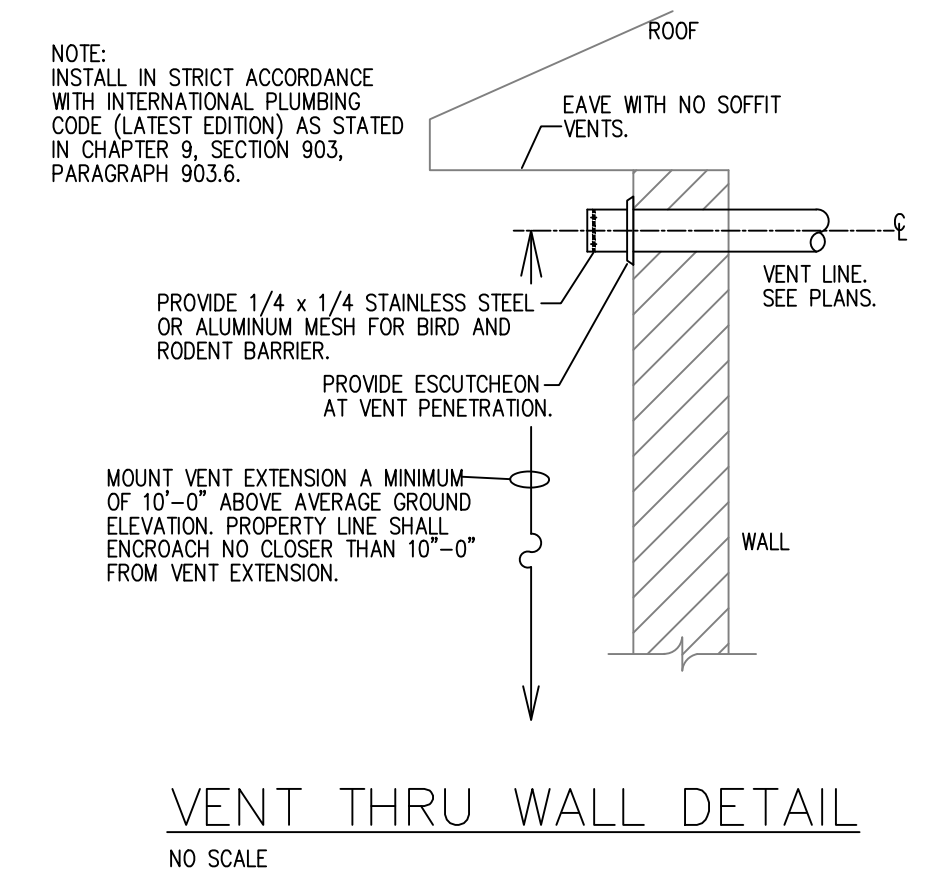
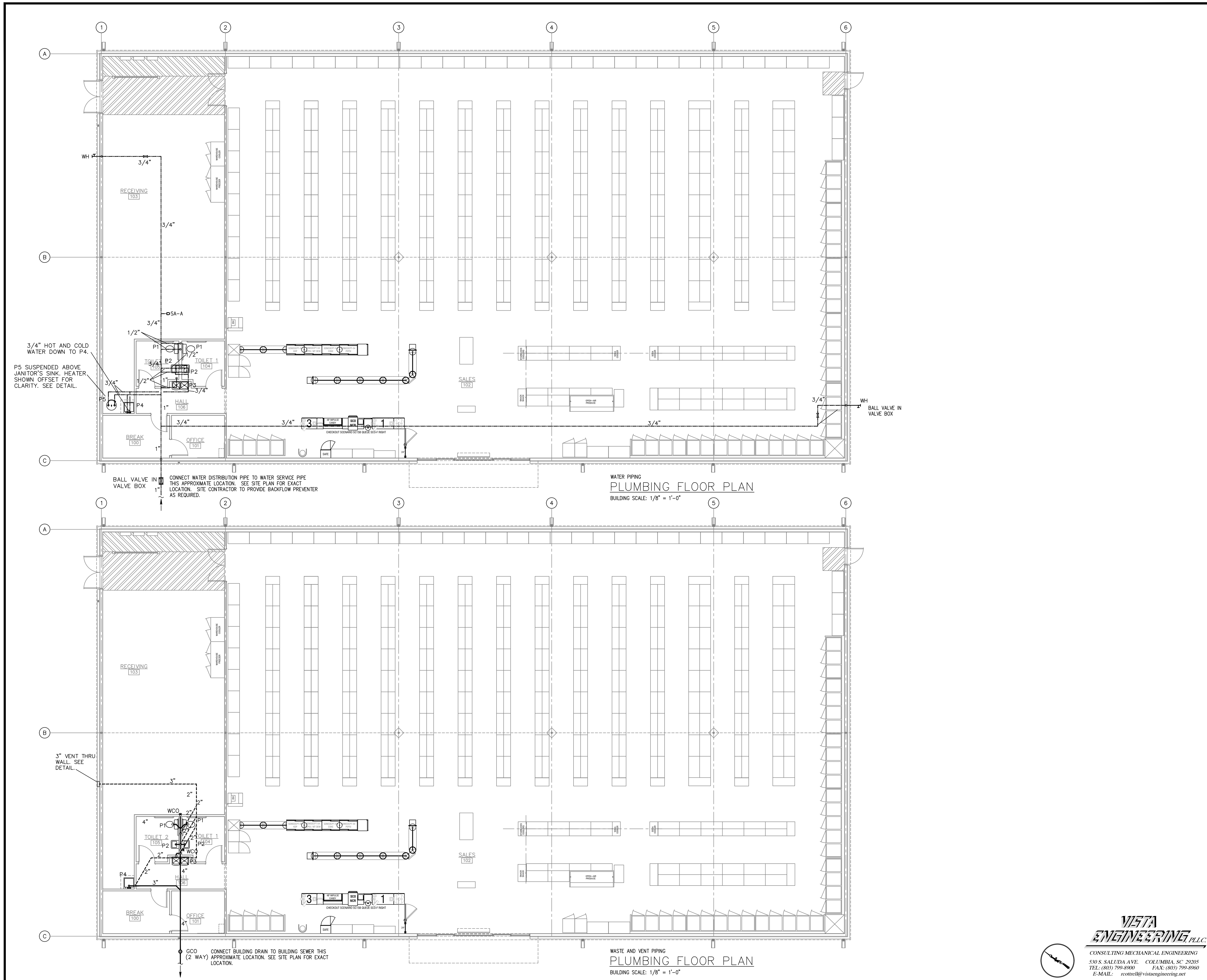

**JOHN P. WATKINS, ARCHITECT**  
 56 HILLMARK DRIVE  
 COLUMBIA, SOUTH CAROLINA 29210

**Craig A. Otto**  
 ARCHITECT, INC.  
 DESIGN • PLANNING • ARCHITECTURE

5044 Augusta Road  
 Lexington, South Carolina 29072  
 Phone (803) 957-9004  
 Fax (803) 957-2050

No.	Revisions	Date

All rights reserved. This drawing and the design shown thereon are copyrighted as prescribed by the laws of the United States and are the sole property of Craig A. Otto, Architect, Inc. Anyone duplicating, reproducing, or causing to be reproduced these drawings or the design thereon without permission of the architect will be subject to legal action.

Project Title **DOLLAR GENERAL #23725**  
 US 421 S, LILLINGTON, NC

Drawing Title **PLUMBING FLOOR PLANS, DETAIL**

Consultant **VISTA ENGINEERING, LLC**

Seal: Date: **DECEMBER 8, 2021**  
 Drawn By: **COTTRELL**  
 Drawing No.: **P1.1**

**VISTA ENGINEERING, LLC**  
 CONSULTING MECHANICAL ENGINEERING  
 530 S. SALUDA AVE. COLUMBIA, SC 29205  
 TEL: (803) 799-8900 FAX: (803) 799-8960  
 E-MAIL: [cottrell@vistaengineering.net](mailto:cottrell@vistaengineering.net)

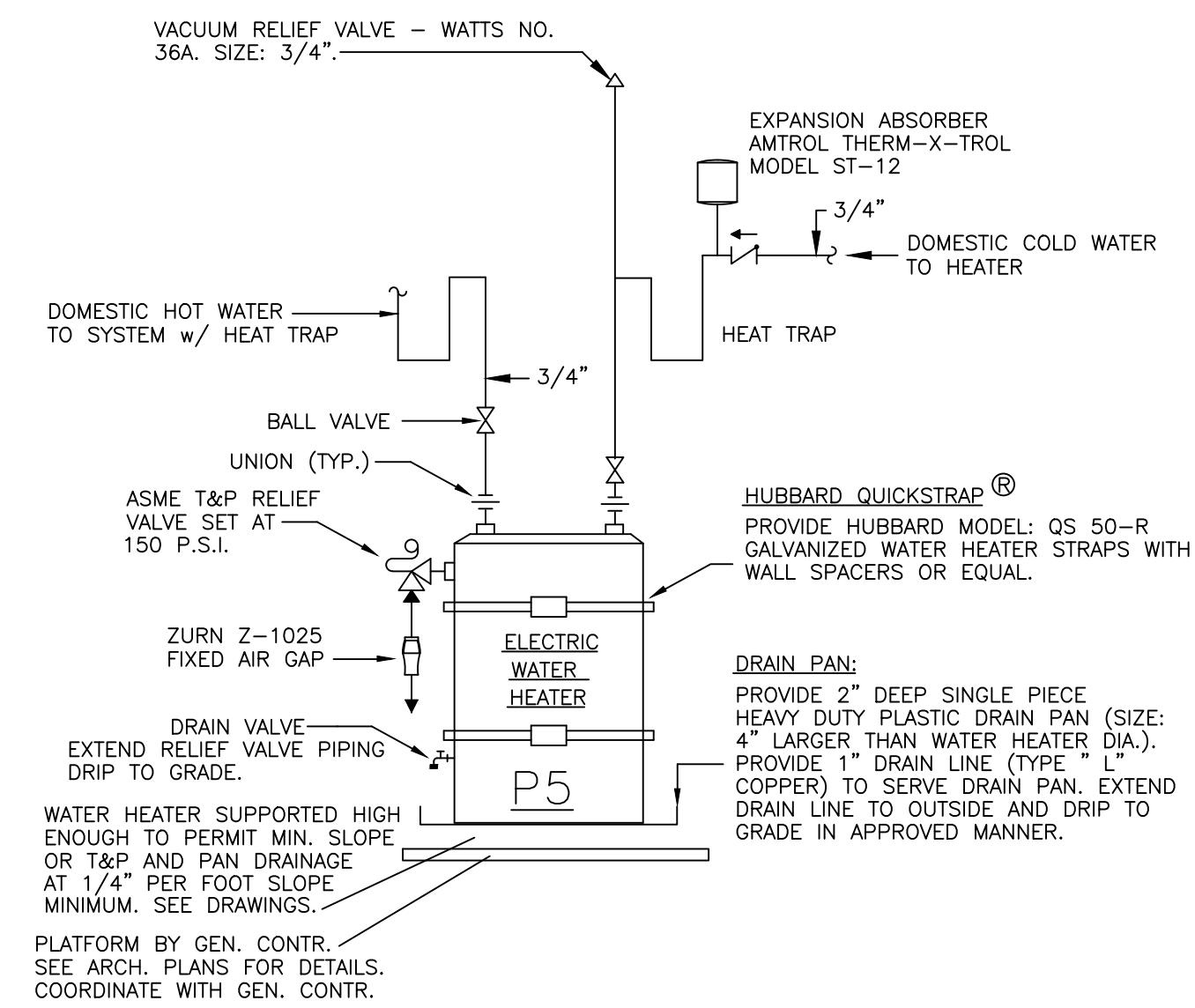

WATER HEATER DETAIL  
N.T.S.

## PLUMBING NOTES

- DO NOT SCALE PLUMBING DRAWINGS. ROUGH FROM ARCHITECTURAL DRAWINGS AND EQUIPMENT MANUFACTURER'S CERTIFIED DRAWINGS. SEE ARCHITECTURAL DRAWINGS FOR EXACT DIMENSIONS, FIXTURE LOCATIONS, ETC.
- DIMENSIONS ARE IN INCHES UNLESS OTHERWISE NOTED.
- UNLESS OTHERWISE SHOWN OR NOTED, LOCATE ALL PIPING ABOVE CEILING.
- WHEREVER THE WORD "PROVIDE" IS USED, IT SHALL MEAN "FURNISH AND INSTALL COMPLETE AND READY FOR USE."
- EXCEPT WHERE PIPE SPACE IS PROVIDED, OR UNLESS OTHERWISE NOTED, ALL SUPPLY, WASTE, SOIL AND VENT RISERS SHALL RUN IN WALLS OR PARTITIONS.
- LOCATE HOSE BIBBS, AND / OR WALL HYDRANTS 2'-0" ABOVE FINISHED FLOOR AND / OR GRADE.
- COORDINATE CLOSELY WITH ALL OTHER TRADES FOR WORK DONE UNDER THIS CONTRACTOR TO AVOID INTERFERENCE OR CONFLICT.
- ALL HOSE BIBBS AND VALVES WITH THREADED HOSE CONNECTIONS SHALL BE EQUIPPED WITH A WATTS REGULATOR COMPANY NO. 8 BACK SIPHONAGE BACKFLOW PREVENTER, AND VACUUM BREAKER OF FINISH TO MATCH HOSE BIBB OR WALL HYDRANT.
- COORDINATE WITH SITE CONTRACTOR FOR CONTINUATION OF UTILITIES.
- PROVIDE ACCESS TO ALL EQUIPMENT REQUIRING CLEANING OR ADJUSTMENT. IF ACCESS DOORS ARE REQUIRED, THEY SHALL BE EQUAL TO KEES, INC. STYLE K IN NON RATED APPLICATIONS AND KEES, INC. STYLE AP-FR IN RATED APPLICATIONS.
- SEE ELECTRICAL DRAWINGS FOR ELECTRICAL CHARACTERISTICS. ELECTRICAL CHARACTERISTICS SHALL BE VERIFIED BEFORE ORDERING EQUIPMENT.
- EXPOSED WASTE AND WATER PIPING UNDER HANDICAPPED LAVATORIES SHALL INSULATED WITH TRUE-BRO, INC. #103 PROTECTIVE UNDER SINK DRAIN PIPING AND ANGLE VALVE SUPPLY COVERS IN WHITE.
- ALL PIPING IS SHOWN DIAGRAMMATIC. HOWEVER, CONTRACTOR SHALL PROVIDE ALL REQUIRED FITTINGS, PIPING AND INSULATION FOR ALL OFFSETS, AND / OR CHANGES IN ELEVATION.
- ALL PIPING SHALL BE SUPPORTED IN ACCORDANCE WITH THE SPECIFICATIONS AND FURTHER SUPPORTS OR HANGERS SHALL BE PROVIDED TO PREVENT THE WEIGHT OF THE PIPING BEING PLACED ON THE EQUIPMENT.
- CONTRACTOR SHALL VERIFY ACTUAL LOCATIONS AND INVERTS OF EXISTING UTILITIES PRIOR TO START OF CONSTRUCTION.
- COORDINATE LOCATION OF NEW PIPING LOCATED BELOW BUILDING WITH STRUCTURAL PLANS AND OTHER TRADES TO AVOID CONFLICT.

## PLUMBING FIXTURE SCHEDULE

MARK	BASIS OF DESIGN	CW	HW	W	V
P1	HANDICAPPED WATER CLOSET: KOHLER MODEL K-3979 WELLWORTH CLASS 5 FLUSHING SYSTEM COMFORT HEIGHT, FLOOR MOUNTED TANK TYPE ELONGATED SIPHON JET, 16-1/2" HIGH, 12" ROUGH, BOLT CAPS, BENEKE 523-SS HEAVY DUTY WHITE SEAT, AND MCGUIRE H-166 BRASS ANGLE STOP. FURNISH POLY RISER AND WAX RING. FURNISH WITH TRIP LEVER RIGHT OR LEFT HAND AS REQUIRED TO MEET ADA.	1/2"		4"	2"
P2	WALL HUNG LAVATORY: KOHLER MODEL K-2005 KINGSTON SPLASH BACK 21" X 18" WHITE CHINA LAVATORY, 4" CENTER SET, DELTA 501-WF FAUCET WITH SINGLE LEVER HANDLE, GRID STRAINER, 1-1/4" TUBULAR P-TRAP, AND BRASSCRAFT R-1912-A SUPPLIES. FURNISH WITH TRU-BRO 102 TRAP AND SUPPLY COVERS IN WHITE.	1/2"	1/2"	2"	1-1/2"
P3	WATER COOLER: OASIS MODEL P1F8WMD DUAL LEVEL COOLER UNIT. PROVIDE WITH SUPPLY STOP, P-TRAP WITH CLEAN OUT TO BASIN. CABINET SHALL BE STANDARD FINISH. MOUNT UNIT ON WALL SO THAT RIM IS HEIGHT AS RECOMMENDED BY UNIT MANUFACTURER.	1/2"		2"	2"
P4	JANITOR'S RECEPTOR: FLORESTONE MODEL 20, 24" X 24" X 12" FLOOR RECEPTOR WITH CHICAGO NO 897 FAUCET, T-35 HOSE AND WALL BRACKET, T-40 MOP HANGER BRACKET AND 3" P-TRAP BELOW FLOOR. FIXTURE TO BE CAULKED WITH SEALANT AFTER INSTALLATION.	1/2"	1/2"	3"	1-1/2"
P5	WATER HEATER: A.O. SMITH ELSC-15S, 15 GALLON STORAGE, DUAL NON SIMULTANEOUS 1.5 KW HEATING ELEMENTS, 120-1-60. PROVIDE FACTORY INSTALLED P&T RELIEF VALVE, BRASS DRAIN VALVE AND FACTORY WARRANTY.	3/4"	3/4"		
WH	WALL HYDRANT: WOODFORD MODEL 65 ANTI-SIPHON AUTOMATIC DRAINING FREEZELESS WALL HYDRANT, SHALL MEET ASSE STANDARD 1019-B, LISTED BY IAPMO, AND MEET GOVERNMENT SPECIFICATION WW-541B TYPE 205. COMPLETE WITH NIDEL MODEL 34HA VACUUM BREAKER WITH 3/4" THREAD MALE HOSE ADAPTOR, UNDER NOZZLE DRAIN, LOOSE KEY OPERATED (DELIVER KEYS TO OWNER) AND WITH CHROME FINISH ON BRASS CASTING.	3/4"			
FOO	FLOOR CLEANOUT: ZURN Z-1400, HEAVY DUTY CAST IRON CLEANOUT WITH UP TO 2" HEIGHT ADJUSTMENT.			4"	

FIXTURES LISTED ABOVE ARE FOR BIDDING PURPOSES ONLY. FIXTURE MANUFACTURER, MODEL, STYLE, COLOR ETC. SHALL BE APPROVED BY ARCHITECT AND OWNER.

NOTE:

## SHOCK ARRESTOR SCHEDULE

PURSUANT TO: STANDARD PDI-WH 201

MARK	BASIS OF DESIGN	SIZING
SA-B	SHOCK ARRESTOR: PRECISION PLUMBING PRODUCTS, INC. MODEL NUMBER: SC-750 BARREL FABRICATED HARD DRAWN COPPER, BROUGH COPPER FITTINGS WITH BRASS PISTON AND THREADED ADAPTOR. "O" RING SEALS, PARKER SPEC. (N951-79).	3/4"

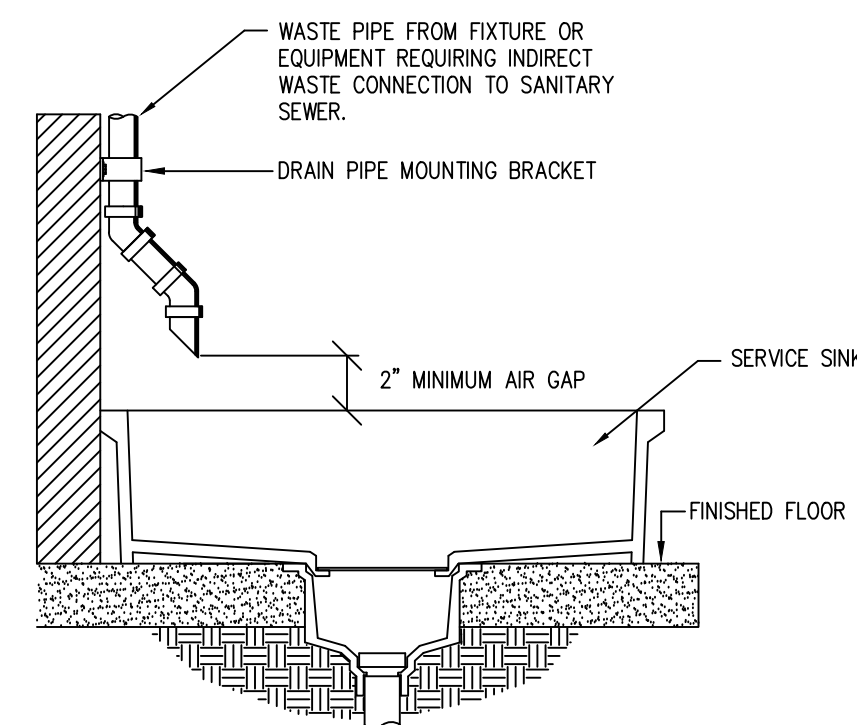

INDIRECT WASTE PIPING DETAIL

N.T.S.

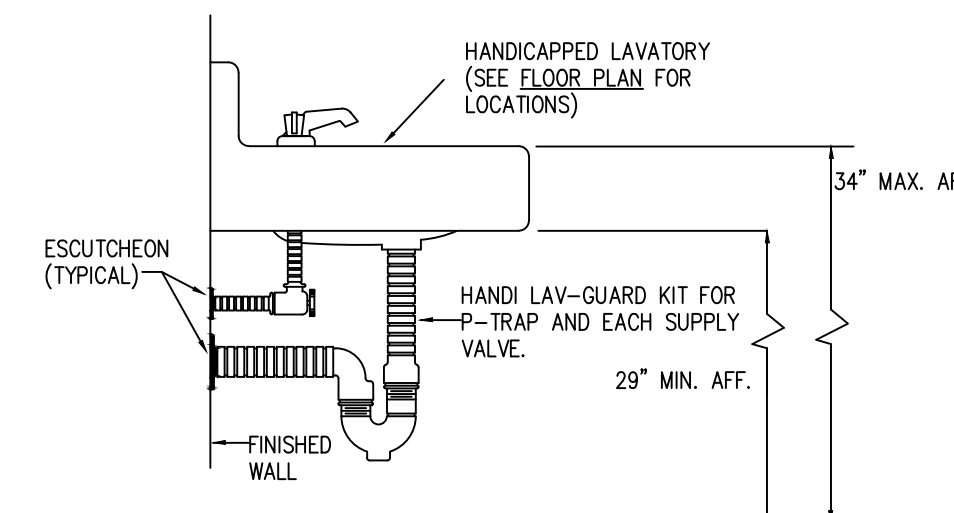

TRAP INSULATION DETAIL

N.T.S.

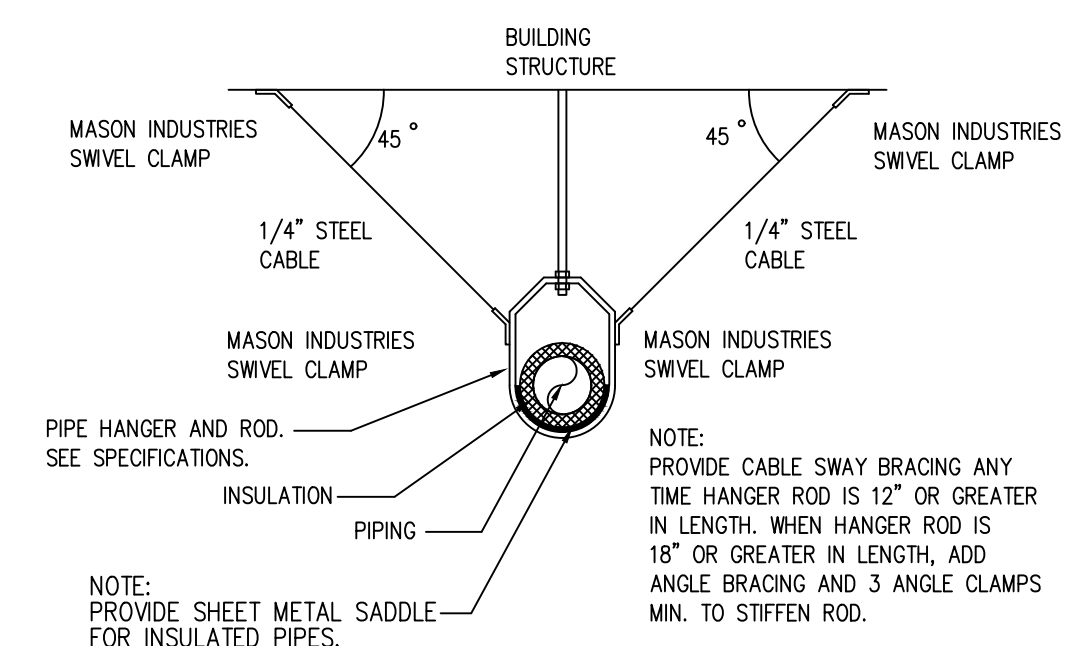

SEISMIC PIPE BRACING DETAIL

N.T.S.

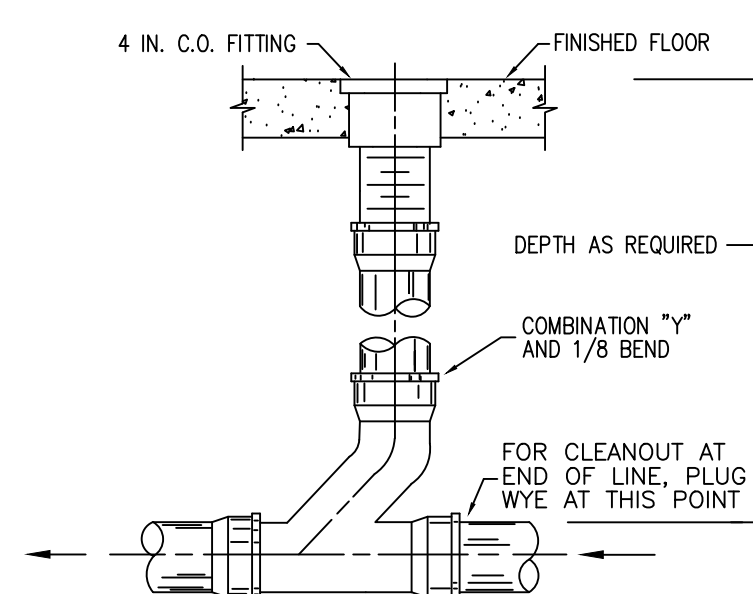

FLOOR CLEANOUT DETAIL

N.T.S.

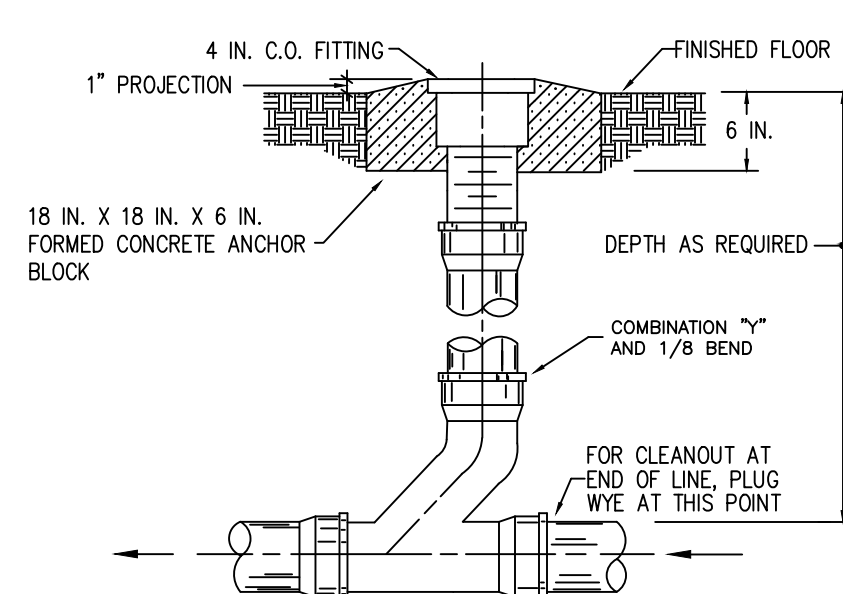

CLEANOUT TO GRADE DETAIL

N.T.S.

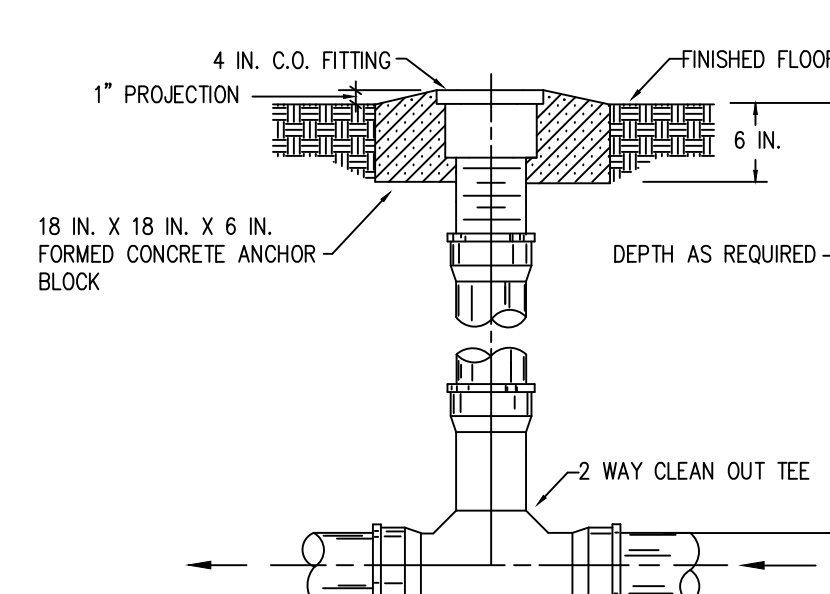

TWO WAY CLEANOUT DETAIL

N.T.S.

## PLUMBING SYMBOLS

SYMBOL	DESCRIPTION
	WASTE PIPING
	WASTE VENT PIPING
	VENT THRU ROOF
	HOT WATER PIPING
	HOT WATER RECIRCULATION PIPING
	COLD WATER PIPING
	PIPE TURNS TO, AWAY
	CAP AT END OF LINE
	WALL HYDRANT
	BALL VALVE
	BALL VALVE IN VALVE BOX
	SHOCK ARRESTOR
	GRADE CLEANOUT
	FLOOR DRAIN WITH FUNNEL
CW	COLD WATER
HW	HOT WATER
A/C	ABOVE CEILING
B/S	BELOW SLAB
B/G	BELOW GRADE
RP	RECIRCULATION PUMP

JOHN P. WATKINS, ARCHITECT  
56 HILLMARK DRIVE  
COLUMBIA, SOUTH CAROLINA 29210

Craig A. Otto  
ARCHITECT, INC.

DESIGN • PLANNING • ARCHITECTURE

5044 Augusta Road  
Lexington, South Carolina 29072  
Phone (803) 957-9004  
Fax (803) 957-2050

No.	Revisions	Date

All rights reserved. This drawing and the design shown thereon are copyrighted as prescribed by the laws of the United States and are the sole property of Craig A. Otto, Architect, Inc. Anyone duplicating, reproducing, or causing to be reproduced these drawings or the design thereon without permission of the architect will be subject to legal action.

Project Title DOLLAR GENERAL #23725  
US 421 S, LILLINGTON, NC

Drawing Title PLUMBING SCHEDULES, DETAILS

Consultant VISTA ENGINEERING, LLC

Seal 	Signature 	Date DECEMBER 8, 2021
	Drawn By COTTRELL	Drawing No. P2.1

VISTA  
ENGINEERING, LLC

CONSULTING MECHANICAL ENGINEERING  
530 S. SALUDA AVE. COLUMBIA, SC 29205  
TEL: (803) 799-8900 FAX: (803) 799-8960  
E-MAIL: rcottrell@vistaengineering.net

12.08.2021

# PLUMBING SPECIFICATIONS

## SCOPE

Drawings and specifications are complementary and what is called for by one shall be as binding as if called for by both. Provide all supervision, labor, material, equipment, machinery, plant and any other items necessary for a complete, safe and operating plumbing system. Provide accessories in accordance with manufacturer's recommendations for the conditions encountered. Examine other drawings and specifications and bring to the attention of the Architect prior to bid time any omissions, errors, or discrepancies in this division. Work includes the study of all contract documents, the preparation of shop drawings, and coordination with other trades as necessary to install systems. Systems are to be installed as close to the details of contract documents as possible. Submit complete layout shop drawings for all work for review unless otherwise approved.

## CODES, RULES, PERMITS, AND FEES

Permits, fees, including all sanitary sewer and/or water tapping fees, etc. are included. Comply with all City, County, and State applicable laws, ordinances, codes, rules and regulations. Deliver certificates and permits to Architect. All material and work shall comply with the National Fire Codes of the NFPA, National and local codes. Deliver to Architect, permits and licenses including certificates from local and State Health Departments, approving complete sanitary sewer and water systems.

## DRAWINGS

Drawings are schematic and indicate only the general arrangement of systems and work included in the contract. Provide all offsets, fittings as may be required to install system, etc., without extra charge.

## DAMAGES

Cost of repairing damage to building, building contents, and site during construction and guarantee period resulting from this work is a part of this contract.

## MANUFACTURER'S INSTRUCTIONS AND RECOMMENDATIONS

Prior to purchasing equipment procure product manufacturer's recommendations, application, installation and rough-in instructions for use in conjunction with the system design drawings and specifications during construction. All printed recommendations shall be kept in a folder on the job site, shall be made available to the Architect/Engineer when requested, and shall be turned over to the Architect before the final project visit.

## ELECTRICAL CONNECTIONS

Electrical characteristics indicated on drawings or in specifications are design values only. Verify actual electrical characteristics to be used on project before ordering equipment. All motors shall be protected with magnetic starters or with built-in thermal overload protection. Provide starters with "Hand-off-Auto" switch. Provide overload protection in all phases. The electrical Contractor shall provide all wiring except: temperature control wiring, equipment control wiring, and interlock wiring. The electrical Contractor shall furnish and install all power wiring complete from power source to motor or equipment junction box, including power wiring through starters. Electrical Contractor shall install all starters not factory mounted on equipment. This Contractor shall, regardless of voltage, provide all interlock wiring, and equipment control wiring for equipment provided under this Division. This Contractor shall furnish all starters and contactors to the electrical. This Contractor shall provide and be responsible for overload heaters in all starters furnished. Starters shall be provided with a heater in each ungrounded conductor.

## INSTRUCTIONS TO OWNER

Contractor shall conduct a maintenance and operational instruction session for the Owner. Where highly technical or complex equipment is supplied, such as domestic booster pump packages. Manufacturer's representatives and other appropriate personnel who are particularly qualified, shall conduct training sessions pertaining to their equipment, or systems. Such training shall be scheduled with the Owner in advance.

## SAFETY PRECAUTIONS

Provide all warning signs, barriers, covers, rails, belts, and other appurtenances required to protect workers, the public, and the owner's personnel in the vicinity of the project. Comply with requirements of OSHA, municipal and insurance regulations, and reasonable standards of good practice.

## SHOP DRAWINGS AND SUBMITTALS

Submit detailed shop drawings for all equipment and materials as supplied for this project. All data shall be submitted in one submission. Partial submissions shall not be accepted. Submittals shall be stamped "SUBMITTED FOR APPROVAL" and shall contain the Contractor's name and date indicating Contractor has read the submittals and is aware of contents of submission. Shop drawings submitted for review shall be detailed, dimensioned drawings or catalog pages showing construction, size, arrangement, operating clearances, performance characteristics and capacity. Samples, drawings, specifications, and catalogs submitted for review shall be properly labeled indicating specific service for which material or equipment is to be used, section and article number of specifications governing, Contractor's name, and name of job. The Contractor shall make layout shop drawings for work that is to be installed under this Division of the Contract. Layout drawings shall be based on the study of all contract documents and actual on-site conditions when applicable. The Contractor shall be responsible for all dimensions and space conditions. Review rendered on shop drawings shall not be considered as a guarantee of measurements or building conditions. WHERE DRAWINGS ARE REVIEWED, SAID REVIEW DOES NOT MEAN THAT DRAWINGS HAVE BEEN CHECKED IN DETAIL; SAID REVIEW DOES NOT IN ANY WAY RELIEVE THIS CONTRACTOR FROM HIS/HER RESPONSIBILITY OR NECESSITY OF FURNISHING MATERIAL OR PERFORMING WORK AS REQUIRED BY THE CONTRACT DRAWINGS AND SPECIFICATIONS.

## OR EQUAL

Specific reference in the plans or specifications to any article, device, product, materials, fixture, form or type of construction, etc., by name, make, or catalog number, with or without the words "or equal," shall be interpreted as establishing a standard of quality and shall not be construed as limiting competition and the Contractor in such cases may, at his/her option, use any article, device, product, material, fixture, form or type of construction which, in the judgment of the Architect/Engineer expressed in writing, is equal to that named. Where quality and other characteristics are very nearly the same, the question of determining equal materials and readily available service sometimes resolves itself to a matter of personal opinion and judgment and in these and all other cases involving the approval of materials, the opinion, judgment, and decision of the Architect/Engineer and the Owner shall be final and bind all parties concerned. Requests for substitutions shall be submitted in the form of a letter (with one copy minimum) on letterhead of submitting firm. Letter to be addressed to the Engineer and referenced to this job. Items to which the Engineer has given an "OK" to quote shall not be construed as authorizing any deviations from the plans and specifications. This Contractor shall be responsible for verifying all dimensions with available space conditions with provisions for proper access, maintenance, and part replacement, and for coordination with other trades - electrical, HVAC, structural, etc. for proper service and construction requirements. If a substituted item requires a different quantity and arrangement of piping, structural supports, insulation, controllers, motors, starters, electrical wiring and conduit and any other additional equipment required by the system, such equipment shall be provided at no additional cost to the Owner.

## STATEMENT OF COMPLETION

Prior to substantial completion, Contractor shall furnish Architect and Engineer, two (2) copies of the following statement, signed by the Contractor: "Contract Documents have been reviewed and construction of the plumbing systems are complete and in accordance with contract documents to the best of my knowledge and belief. Plumbing systems are ready for Architect and Engineer's review." Prior to substantial completion of this project, the following shall be complete: Preparation and submittal to Architect/Engineer of a list of items to be completed or corrected; Instruction Manual; Maintenance Checklists; Start-Up Reports; Record Drawings; Testing, Adjusting and Balancing; Statement of Completion; and test report results.

## PROJECT CLOSEOUT

At the end of construction, furnish to the Architect three (3) bound and indexed sets of maintenance and operating instructions, parts lists, electrical wiring diagrams, balance data, and manufacturer's literature sufficient for operation and complete maintenance of all equipment by the Owner. Approved submittals and shop drawings may be included in the Maintenance Manuals instead of being separately furnished, if desired. It is intended that the documentation provided in maintenance manuals, along with as-built drawings, shall be complete and detailed enough to permit and facilitate troubleshooting, engineering analysis, and design work for future changes, without extensive field investigations and testing. Manuals shall be prepared so as to explain system operation and equipment to those not acquainted with the job. Manuals shall be durable bound and clearly identified on the front cover (and on the spine of thick volumes). Identification shall include the building or project name, applicable trade (such as Plumbing, Fire Protection, etc.), approximate date of completion (month and year) and contractor's name. Manuals shall be organized into well defined and easy to locate sections, with index tabs or separators to divide the sections. A complete table of contents shall be provided at the front indicating the section or page number for each system, subsystem, or supplier/manufacturer. Manuals shall include complete information and diagrams on all controls, indicators, sensors, and signal sources. Catalog data and cuts shall be clearly marked to indicate model numbers, sizes, capacities, operating points, and other characteristics of each item used. This should include accessories and special features provided. Where various sizes or variations of a series or model are used, documents should clearly show which are used where. Where quantities are appropriate, schedule of usage should be provided. Maintenance literature shall include complete information for identifying and ordering replacement parts, such as illustrated parts breakdowns. Maintenance manuals must include complete test results on all systems.

## SITE CONDITIONS

When work is existing, all bidders shall visit the site of the work and become familiar with all existing conditions before submitting a bid. Submission of a bid will be considered as evidence that this has been done, and no extra payments will be allowed this Contractor because of extra work made necessary by his/her failure to do so.

## UTILITY INTERRUPTIONS

Obtain Owner's approval for water and/or sewer utility interruptions at least five (5) working days in advance of all scheduled interruptions. Contractor shall arrange work so that interruptions are minimized in number and duration.

## IDENTIFICATIONS AND NAMEPLATES

All piping, valves, and equipment on this project shall be identified as specified herein. All marks of identification shall be easily visible from the floor or usual point of vision. All equipment, except in finished areas, shall be nameplates identifying the piece of equipment by name and numerical sequence relative to other equipment. Example: EWH-1, P-1, etc. Nameplates shall be 1/8" thick plastic with black background. Letters shall be 1/2" high for equipment and 1/8" high for control devices. Attach nameplates with screws.

## FOUNDATIONS AND SUPPORTS

Provide all necessary foundations, supports, pads, bases and piers required for all equipment, piping, pumps, water heaters and for all other equipment furnished under this contract. For pumps, and other rotating machinery, and for all equipment where foundations are indicated, furnish and install concrete pads as shown. All pads shall be extended 4" beyond machine base all directions with top edge chamfered. Insert 6" long steel dowel rods into floors to anchor pads.

## PAINTING AND COLOR CODING

All new equipment, piping and materials exposed to view shall be painted as required except equipment furnished with factory-painted finishes. All new equipment and materials shall be completely sanded, primed and repainted where factory-paint has been scratched. Paint shall be as recommended by equipment manufacturer. Paint all supports, hangers, angles, and all other unpainted metal with two coats of high heat aluminum paint.

## WORKMANSHIP

Workmen shall be thoroughly experienced and fully capable to installing assigned work. Work shall be in accordance with the best practice of the trade, as recommended by the manufacturer and/or as approved by the Engineer. Work that is not of good quality in the opinion of the Engineer shall be removed and reinstalled. An experienced superintendent shall be continuously in attendance on the job during all phases of construction of the building, to coordinate and supervise the work.

## COORDINATION

Prior to starting work, coordinate with all other trades and building features to avoid interference and establish necessary space requirements and tie-ins for each trade. Prior to starting installation, furnish to the General Contractor and all contractors concerned, copies of layout shop drawings and approved shop drawings showing location of equipment, piping, etc. Schedule periodic meetings with other trades before and during installation to avoid conflicts and assure that pipes and equipment are installed in the best manner, taking into consideration headroom, maintenance, appearance, replacement and space requirements. No work shall be performed on this project before coordinating all space requirements for ducts, pipes, conduits, etc. with all contractors concerned. Locate and provide all holes and sleeves required for the installation of the materials installed under this Section. Any holes or sleeves not installed while floors, walls and ceilings are being constructed shall be cut and patched by this Contractor under the supervision of the General Contractor.

## CUTTING AND PATCHING

Provide all cutting and patching necessary to install the work specified in this Section. Patching shall match adjacent surfaces. Lay out work in advance and establish location of chases, inserts, sleeves, access panels, etc. Provide inserts, sleeves, access panels, supports, etc and check for proper installation.

## EVACUATION AND BACKFILLING

Perform all excavation and backfilling required for work under this Division of the specifications. Install sewer and water pipes in separate trenches, graded uniformly to provide solid bearing and required fall. Dig bell holes at hubs. Remove rock for one (1) foot below pipe and replace with sand. Upon completion of tests and inspections, backfill with approved material, placed and tamped in 6" layers to prevent excessive settlement.

## RECORD DRAWINGS

The Contractor shall maintain on the job site one (1) complete set of drawings for this project. All changes as to the locations, sizes, substituted material and equipment, etc., of piping, fixtures and all other material and equipment shall be indicated in red pencil on the drawings as the work progresses. Before substantial completion, the Contractor shall obtain, at his/her expense, a set reproducible plastic (mylar) drawings, on which shall be indicated the information outlined above. Drawings (including schedules, details and sections) shall be corrected to depict all substituted material and equipment.

## PRE-CONSTRUCTION CONFERENCE

The Contractor shall plan a pre-construction conference after he/she has thoroughly reviewed the plans, specifications and site. Conference shall be held at the Engineer's office (or at an agreed upon location) at a time agreeable to both parties. Proposed lists of equipment to be used along with manufacturer's recommended installation details should be brought to the conference.

## CONCEALED WORK

Unless otherwise approved, no work shall be covered or concealed without notifying the Architect or Engineer in writing at least three (3) days in advance. Any work covered or concealed without such notice may require uncovering for examination at the Contractor's expense.

## VIBRATION ISOLATION AND SEISMIC RESTRAINT:

The work in this section consists of furnishing engineering, labor, equipment, materials, appliances, tools, permits, and in performing all operations and services necessary for and/or incidental to vibration isolation and seismic restraints and other related equipment for the subject project. Unless otherwise specified, all mechanical equipment, piping, and ductwork shall be restrained to resist seismic forces. Restraints shall maintain equipment, piping, and ductwork in a captive position. Restraint devices shall be designed and selected to meet the seismic requirements as defined in the latest issue of the 2018 International Building Code and to SMACNA Seismic Restraint Manual Guidelines for Mechanical Systems LATEST Edition. The Isolators and seismic restraint systems shall be manufactured by Amber/Booth. Approved equals by Mason Ind., or Vibration Mountings and Controls, who meet all the requirements of the specifications are acceptable. All isolation materials, flexible connectors and seismic restraints shall be of the same manufacturer and shall be selected and certified using published or factory certified data. Any variance or noncompliance with these specification requirements shall be corrected by the contractor in an approved manner. The contractor and manufacturer of the isolation and seismic equipment shall refer to the isolator and seismic restraint schedule which lists isolator types, isolator deflections and seismic restraint type.

## MANUFACTURER RESPONSIBILITIES

Manufacturer of vibration and seismic control products shall have the following responsibilities: Determine vibration isolation and seismic restraint sizes and locations. Provide piping, and equipment isolation systems and seismic restraints as scheduled or specified. Provide installation instructions and shop drawings in accordance with other provisions of this section of the specifications. Provide calculations to determine restraint loads resulting from seismic forces presented in the International Building Code 2006, Chapter 16. Seismic calculations shall be certified by an engineer licensed in the locality of this project and in the employ of the seismic equipment supplier. Anchor bolt calculations, certified by a qualified licensed engineer shall be submitted showing adequacy of bolt sizing and type. Calculations or testing shall be furnished for anchors on restraint devices, cables, and rigidly mounted equipment. Calculations and restraint device submittal drawing shall specify anchor bolt type, embedment, concrete compressive strength, minimum spacing between anchors and minimum distances of anchors from concrete edges.

## PIPE MATERIALS AND FITTINGS

### WASTE, STORM AND VENT PIPING:

Cast iron ASTM A74 pipe for all pipe and fittings with ASTM C-564 gaskets.

(OPTION): Cast iron CISPI 301, ASTM A888 hubless pipe with ASTM C-1277 shielded hubless couplings.

All pipe and fittings shall be marked with the collective trade marks of CISPI and NSF.

CISPI Designation 310-11, CISPI Designation 301-09, large diameter no-hub cast iron fittings, over 4 inches in size, shall be provided with supplemental support to minimize the risk of joint separation under high thrust conditions. Auxiliary restraint products used shall be manufactured assemblies with thrust pressure rating adequate for the specific installation. Field devised methods and materials shall not be used to accomplish this application solution. Basis of design subject to compliance with requirements shall be Hadrille 117 Series No Hub Fittings Restraints.

(OPTION): PVC SCHEDULE 40 DWV pipe and fittings with solvent joints.

All buried PVC pipe shall be installed per ASTM D-2321.

### WATER PIPING (BURIED OR BELOW GRADE):

ASTM B88, TYPE K, hard drawn copper tubing with cast brass or copper fittings and Grade 95TA solder joints.

### WATER PIPING (ABOVE GRADE OR WITHIN BUILDING):

ASTM B88, TYPE L, hard drawn copper tubing with cast brass or copper fittings and GRADE 95TA solder joints. No fittings allowed below slab.

(Option): ASTM F876 PEX (cross linked polyethylene) piping, minimum 100 PSIG pressure rating with ASTM D 2603, 2683, 3261 and ASTM F 1005 fittings. Install in strict accordance with manufacturer's instructions and Table 605.4 and Table 605.5 of the 2012 International Plumbing code.

### INSULATION:

Insulate all hot and cold water piping with 1" thick fiberglass insulation with Kraft paper moisture barrier. Seal joints and seams with plastic mastic with fiberglass tape. Provide saddles at harness points.

(OPTION): Insulate all hot and cold water piping with 1" thick ARMAFLEX flexible closed cell expanded foam insulation installed according to manufacturer's recommendations. Seal all joints air tight. Provide saddles at hanger points.

## VALVES

### SWING CHECK VALVES:

NIBCO MODEL T433 / S433, HAMMOND Model IB945 or POWELL MODEL 1841. Units up to 2" shall be bronze swing disc, solder or screw ends.

### SPRING LOADED CHECK VALVES:

Iron body, bronze trim, spring loaded, renewable composition disc, soldered, reinforced diaphragm, strainer and double union ends. Above 2", cast iron body, screwed, wafer or flanged.

### WATER PRESSURE REDUCING VALVES:

WATTS, HONEYWELL, BRAUKMANN OR A.W. CASH VALVE MANUFACTURING COMPANY up to 2", bronze body, stainless steel and thermoplastic internal parts, fabric reinforced diaphragm, strainer and double union ends. Above 2", cast iron body, bronze fitted, elastomeric diaphragm and seat disc, flanged.

### RELIEF VALVES:

WATTS, A.W. CASH MANUFACTURING CORP. or CONBRACO INDUSTRIES, INC. bronze body, Teflon seat, steel stem and springs, automatic, direct pressure actuated, capacities and ASME CERTIFIED AND LABELED.

### BALL VALVES:

NIBCO MODEL T585-7066 / S585-7066, MILWAUKEE VALVE MODEL BA-100S / BA-05S or WATTS MODEL B-6000SS / B-6001SS.

Up to 2", bronze or stainless steel body, stainless steel ball, Teflon seats and stuffing box ring, lever handled and solder or screwed ends.

### HANGERS

PERFORATED STRAP HANGERS, CHAIN, OR WIRE WILL NOT BE PERMITTED ON THE JOB.

Support horizontal steel or cast iron piping where run above ground with split ring hangers, turnbuckles and threaded rod as manufactured by FEE & MASON or APPROVED EQUAL. Hangers shall be securely fastened to structure and spaced not more than 5'-0" for cast iron pipes, 8'-0" apart for steel piping and 4'-0" for PVC piping.

Support horizontal copper pipes where run above ground with copper or copper plated hangers as manufactured by GRINNELL CO., FEE & MASON or APPROVED EQUAL. Hangers shall be spaced no more than 6'-0" apart for 1/2" and not over 8'-0" apart for larger pipes.

Provide intermediate and supplementary steel where required for proper support of piping and installation of hangers. Group parallel runs of pipe and support by common steel trapeze hangers of adequate dimensions.

Increase hanger size to accommodate insulation and shield size.

### INSTALLATION AND EXECUTION

ALL MATERIALS AND WORK SHALL COMPLY WITH THE LATEST EDITION OF THE INTERNATIONAL PLUMBING CODE 2018, INTERNATIONAL BUILDING CODE 2018, NORTH CAROLINA DEPARTMENT OF HEALTH AND ENVIRONMENTAL CONTROL REQUIREMENTS, AND APPLICABLE LOCAL CODES AND OR ORDINANCES.

PLUMBING FIXTURES FOR THE HANDICAPPED SHALL MEET THE REQUIREMENTS OF ANSI A117.1 (2009) AND THE AMERICANS WITH DISABILITIES ACT (ADA). THIS SHALL INCLUDE PLUMBING FAUCETS, VALVES, DRAINS, ETC.

Plumbing fixtures shall be as specified or as approved by the owner. Provide stop valves and P-traps for all fixtures. Install level and in the best practice of the trade. Caulk, clean and adjust all fixtures as recommended by the installation instructions of the manufacturer. Complete operating plumbing system to be turned over to the owner. The entire system shall be warranted for one year from the date of the CERTIFICATE OF OCCUPANCY except for the water heater(s) and/or the water cooler which may carry their own longer factory warranty. Return to the job site as often as necessary to make adjustments or correct defects for the one year period without cost to the owner.

Coordinate electrical requirements with the electrical contractor as required.

Sterilize all water piping in accordance with the local codes and building officials prior to acceptance by owner and Certificate of Occupancy. Deliver test results from independent testing laboratory to owner.

Pressure and leak test all water piping at a minimum of 150 PSIG for a period of 4 hours and in accordance with local requirements. Test entire waste and sanitary drainage system vent piping by plugging all necessary openings and filling with a minimum of 10'-0" water column or to the top of highest vent.

Deliver complete set of operating instructions, warranties and equipment data to owner. Information shall be in three ring binders and clearly labeled.

### WATER PRESSURE

This Contractor shall obtain static and residual pressure readings at the site before beginning construction. Maximum pressure allowed within the building shall be 80 psig. If site conditions apply, plumbing contractor shall provide within the scope of the original bid, a pressure reducing valve to limit building water pressure to 80 psig. Pressure reducing valve, if required, shall be located in a serviceable location within the mechanical room or other service room, or located in a valve box outside the building structure. Install valve within strict recommendations of unit manufacturer.

### INVERT ELEVATIONS

Ascertain, before beginning construction, the invert elevations of existing sanitary and/or storm drains, manholes, lift station pumps, etc. Produce "Lay Out" drawings as specified and bring to the attention of the engineer, any discrepancies with existing elevations and inverts before beginning work. Failure to provide this information shall not relieve the contractor of responsibility to provide a working plumbing system in accordance with the plans and specifications.

### RETURN AIR PLENUM

Coordinate with HVAC contractor and consult Architectural Drawings to determine if this project incorporates a rated return air plenum. If a plenum is used, all piping and associated insulation will have to be plenum rated for fire and smoke generation levels including ASTM-E84 for both pipe and flat sheet presentations.

### LEAD LEVELS

Lead levels for wetted surfaces of pipes, pipe fittings, plumbing fittings and fixtures shall have a weighted average of not more than 0.25%. No person shall introduce into commerce any pipe, pipe or plumbing fitting, or fixture intended to convey or dispense water for human consumption through drinking or cooking that is not lead free. Content for solder and flux shall be not more than 0.20%.

**JOHN P. WATKINS, ARCHITECT**  
56 HILLMARK DRIVE  
COLUMBIA, SOUTH CAROLINA 29210

**Craig A. Otto**  
ARCHITECT, INC.

DESIGN • PLANNING • ARCHITECTURE

5044 Augusta Road  
Lexington, South Carolina 29072  
Phone (803) 957-9004  
Fax (803) 957-2050

No.	Revisions	Date

All rights reserved. This drawing and the design shown thereon are copyrighted as prescribed by the laws of the United States and are the sole property of Craig A. Otto, Architect, Inc. Anyone duplicating, reproducing, or causing to be reproduced these drawings or the design thereon without permission of the architect will be subject to legal action.

Project Title DOLLAR GENERAL #23725  
US 421 S, LILLINGTON, NC

Drawing Title  
PLUMBING SCHEDULES, DETAILS

Consultant  
VISTA ENGINEERING, LLC

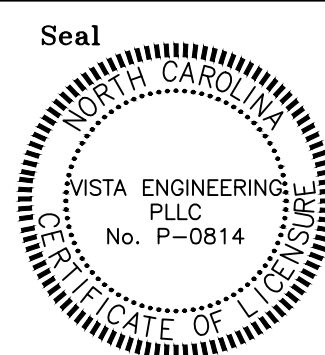

Date  
DECEMBER 8, 2021

Drawn By  
COTTRELL

Drawing No.

P3.1

12.08.2021

**VISTA ENGINEERING, LLC.**  
CONSULTING MECHANICAL ENGINEERING  
530 S. SALUDA AVE. COLUMBIA, SC 29205  
TEL: (803) 799-8900 FAX: (803) 799-8960  
E-MAIL: [cottrell@vistacengineering.net](mailto:cottrell@vistacengineering.net)



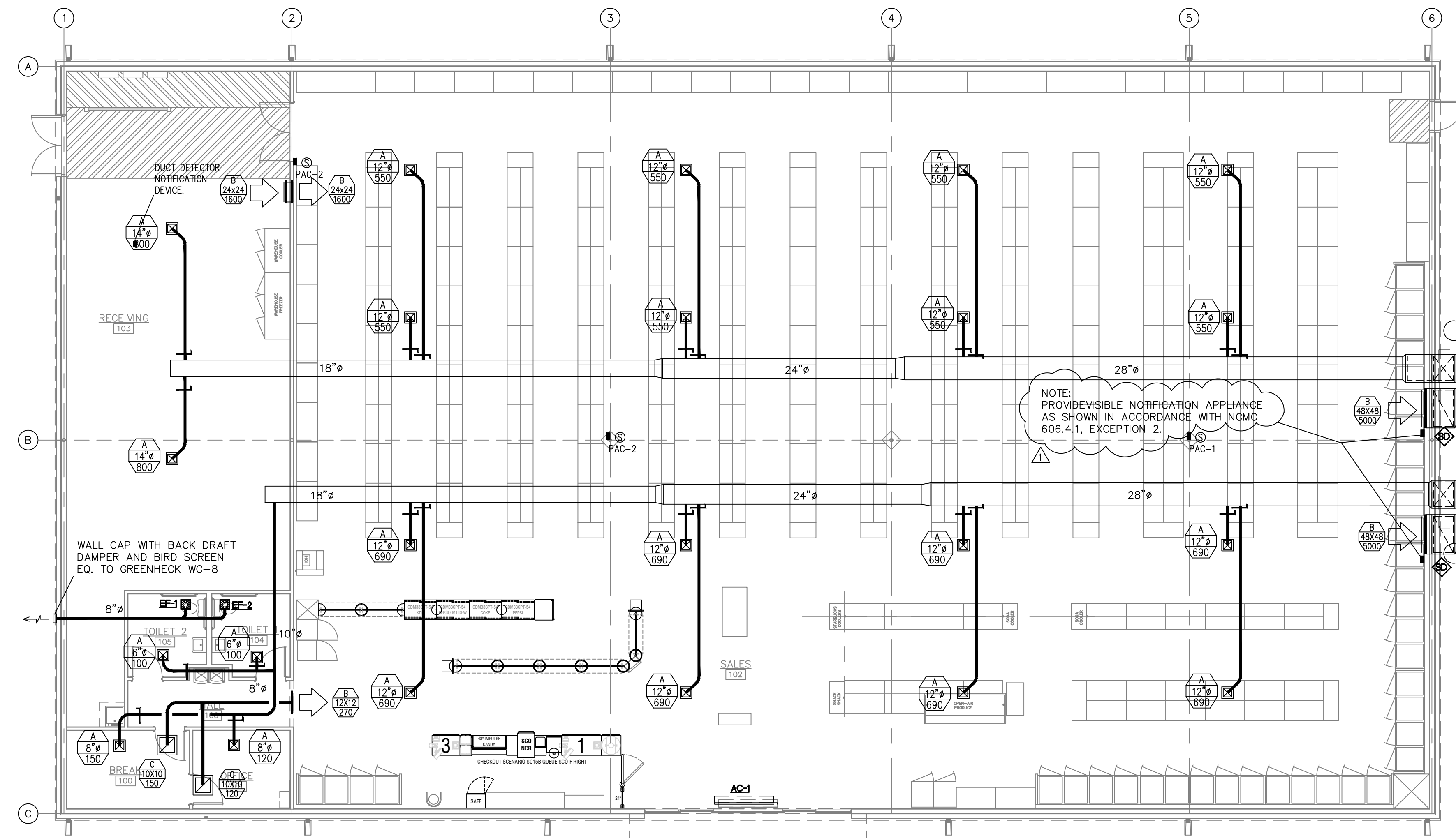

### AIR DISTRIBUTION SCHEDULE

TAG	DESCRIPTION	MOUNT	NECK	CONSTR.	NOTES	BASIS OF DESIGN
A	SUPPLY GRILLE	SURFACE	AS SHOWN	ALUM	1,2,3	PRICE 500
B	SIDEWALL RETURN	SURFACE	AS SHOWN	ALUM	1,2	PRICE 530
C	CEILING RETURN	SURFACE	AS SHOWN	ALUM	1,2	PRICE 80

NOTES:  
 1. SEE REFLECTED CEILING PLAN FOR EXACT LOCATION  
 2. PROVIDE STANDARD BAKED ENAMEL OFF-WHITE FINISH.  
 3. 4-WAY DEFLECTION UNLESS NOTED OTHERWISE

### EXHAUST FAN SCHEDULE

NO.	DESCRIPTION	CFM	SP	VOLT.	WATTS	NOTES	BASIS OF DESIGN
EF-1	CEILING EXH. FAN	75	1/8"	120 V, 1 PH.	100	1,2,3,4,5,6,7	GREENCHECK MODEL SP-A190
EF-2	CEILING EXH. FAN	75	1/8"	120 V, 1 PH.	100	1,2,3,4,5,6,7	GREENCHECK MODEL SP-A190

NOTES:  
 1. SUPPORT BRACKET  
 2. DISCONNECT SWITCH  
 3. CEILING MOUNTED GRILLE  
 4. BACK DRAFT DAMPER  
 5. VIBRATION ISOLATION  
 6. CONTROL BY WALL SWITCH  
 7. SPEED CONTROLLER

### PACKAGED UNIT OPERATING WEIGHT

BASE UNIT: CARRIER MODEL AS LISTED IN SCHEDULE:	PAC-1 OR 2
ECONOMIZER HOOD	1305 LBS.
ELECTRIC HEATER	95 LBS.
OPERATING WEIGHT	1504 LBS.
25% SAFETY FACTOR	1880 LBS.

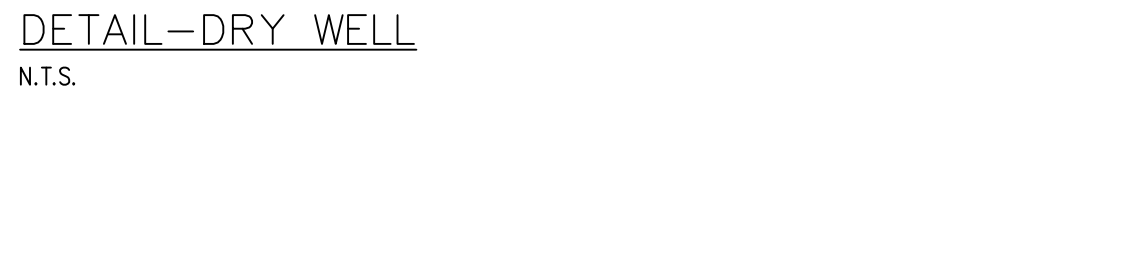
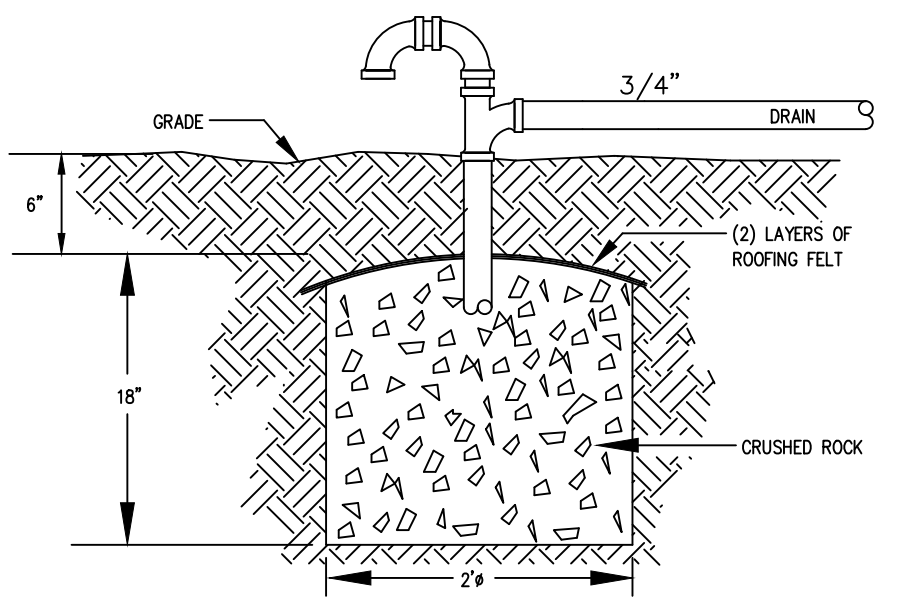
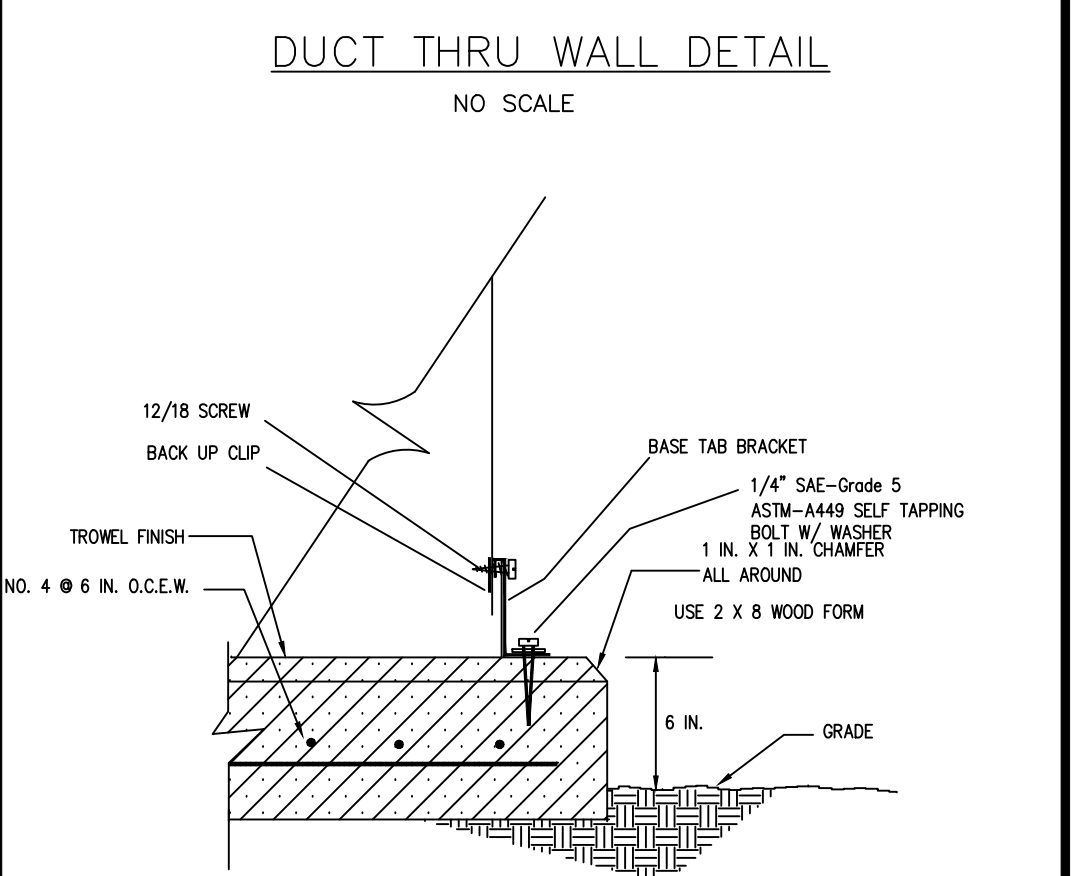
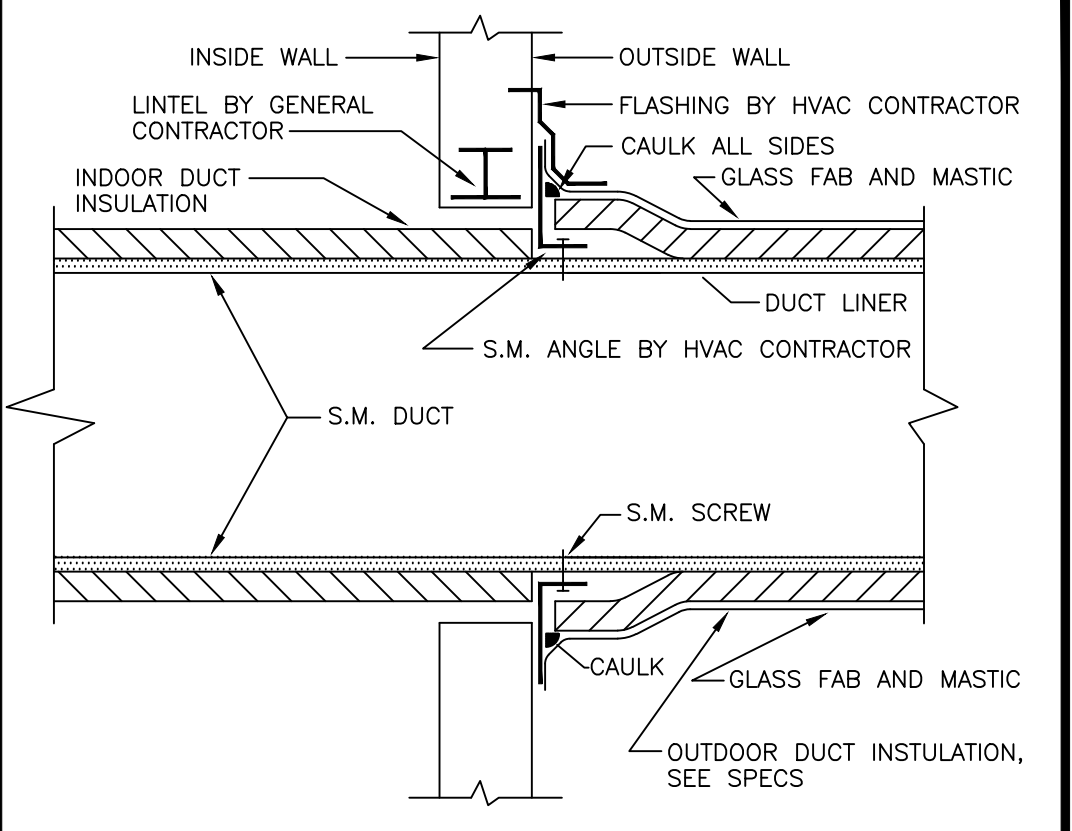

**HVAC FLOOR PLAN**  
 BUILDING SCALE: 1/8" = 1'-0"

**CEILING EXHAUST FAN DETAIL**  
 N.T.S.

**RUNOUT CONNECTION DETAIL (TYPICAL)**  
 N.T.S.

**DETAIL-CONDENSATE TRAP**  
 N.T.S.

### AIR CURTAIN SCHEDULE

NO.	DESCRIPTION	CFM	SP	VOLT.	POWER	NOTES	BASIS OF DESIGN
AC-1	AIR CURTAIN	1800	0.1"	208/2401.60	1/6 HP	1,2,3,4,5,6,7	MARS LPV272-1UD-OB

NOTES:  
 1. OBSIDIAN BLACK  
 2. UNHEATED  
 3. 72" NOZZLE AND UNIT WIDTH  
 4. PROVIDE MICRO SWITCHES AS REQUIRED FOR CONTROL.  
 5. AIR DIRECTIONAL VANES AT OUTLET NOZZLE  
 6. VARIABLE SPEED CONTROL KNOB  
 7. DOOR ACTIVATED MICRO-SWITCH

### PACKAGED AIR CONDITIONING SCHEDULE

TAG	COOLING			ELECTRICAL			FAN			COOLING COIL			HEAT	BASIS OF DESIGN	NOTES	
	NOM. TONS	AMB.	EER	VOLTAGE	MCA	MOPP	CFM	O.A.	ESP	HP	TOTAL MBH	SENS. MBH				ENT. AIR TEMP. DB/WB
PAC-1	15.0	95° F	11.0	208/240/3/60	152.0	175.0	6000	601	3/4"	5.0	184.8	137.0	80.0/67.0° F	50.0	CARRIER 50TC-D16A2A5-0A0G0	1,2,4,5,6,7,8,9
PAC-2	15.0	95° F	11.0	208/240/3/60	152.0	175.0	6000	601	3/4"	5.0	184.8	137.0	80.0/67.0° F	50.0	CARRIER 50TC-D16A2A5-0A0G0	1,2,4,5,6,7,8,9

NOTES:  
 1. 5 YEAR COMPRESSOR WARRANTY  
 2. ECONOMIZER WITH BAROMETRIC RELIEF  
 3. NOT USED  
 4. DUAL SCROLL COMPRESSORS  
 5. SINGLE POINT ELECTRICAL CONNECTION  
 6. FILTER SECTION WITH 30% FILTERS  
 7. AUTO-CHANGEOVER SENSOR WIRED THRU EMS  
 8. LOW AMBIENT CONTROLS  
 9. PROVIDE IONIZING SMOKE DETECTOR IN RETURN AIR STREAM (WITH VISUAL AND AUDIBLE ALARM).

### VENTILATION REQUIREMENTS

ROOM NO.	ROOM NAME	AREA (SF)	MAX. OCCUPANTS	REQUIRED OUTSIDE AIR (CFM/PER)	REQUIRED OUTSIDE AIR (CFM/35)	OSA PER ASHRAE 62.1 (CFM)	CORRECTED OUTDOOR AIR (CFM)
100	BREAK ROOM	116	3	5.0	0.06	22.0	25.0
101	OFFICE	87	1	5.0	0.06	10.2	12.0
102	SALES AREA	8564	68	7.5	0.06	1024	1025
103	RECEIVING AREA	1177	0	0	0.12	141	140

NOTES:  
 1. BASED ON 2015 INTERNATIONAL MECHANICAL CODE, TABLE 403.3

**JOHN P. WATKINS, ARCHITECT**  
 56 HILLMARK DRIVE  
 COLUMBIA, SOUTH CAROLINA 29210

**Craig A. Otto**  
 ARCHITECT, INC.  
 DESIGN • PLANNING • ARCHITECTURE

5044 Augusta Road  
 Lexington, South Carolina 29072  
 Phone (803) 957-9004  
 Fax (803) 957-2050

No.	Revisions	Date
1	NOTIFICATION AND RESET DEVICES REQUIRED AT FLOOR LEVEL AND AS CLOSELY TO RESPECTIVE UNIT AS POSSIBLE.	01.18.2022

All rights reserved. This drawing and the design shown thereon are copyrighted as prescribed by the laws of the United States and are the sole property of Craig A. Otto, Architect, Inc. Anyone duplicating, reproducing, or causing to be reproduced these drawings or the design thereon without permission of the architect will be subject to legal action.

Project Title **DOLLAR GENERAL #23725**  
 US 421 S, LILLINGTON, NC

Drawing Title **HVAC FLOOR PLAN, SCHEDULES, DETAILS**

Consultant **VISTA ENGINEERING, LLC**

Seal: Date: DECEMBER 8, 2021  
 Drawn By: COTTRELL  
 Drawing No.: **M1.1**

**VISTA ENGINEERING, PLLC**  
 CONSULTING MECHANICAL ENGINEERING  
 530 S. SALUDA AVE. COLUMBIA, SC 29205  
 TEL: (803) 799-8900 FAX: (803) 799-8960  
 E-MAIL: rcottrell@vistaengineering.net

### SEQUENCE OF CONTROL

PACKAGED UNITS SHALL BE INDIVIDUALLY CONTROLLED BY WALL/COLUMN REMOTE SENSORS SET FOR SCHEDULES AS REQUIRED BY OWNER AND ACCORDING TO HVAC DESIGN CRITERIA ON DRAWINGS. REMOTE SENSORS SHALL CYCLE UNIT TO PROVIDE HEAT, COOLING AND ZONE CONTROL AS REQUIRED. SEE SPECS.

PROVIDE SMOKE DETECTORS AS SHOWN ON DRAWINGS. LOCATE ALARM LIGHT DIRECTLY BENEATH IT RESPECTIVE THEROSTAT. PROVIDE CLEAR SIGNAGE AS TO WHICH PACKAGED UNIT IS ALARMING NEXT TO ALARM LIGHT.

### HVAC DESIGN CRITERIA

HVAC SYSTEM TYPE	SPLIT SYSTEM AIR COOLED HEAT PUMPS	
ROOF "U" VALUE	0.08	
WALL "U" VALUE	0.08	
GLASS "U" VALUE	0.55	
GLASS SHADING FACTOR	0.63	
OCCUPANCY DENSITY	SHOW ROOM FLOOR	50 PEOPLE
	RECEIVING AREA	2 PEOPLE
	BATHROOMS	0 PEOPLE
OUTSIDE AIR VENTILATION RATE	SHOW ROOM FLOOR	7.5 CFM/PER + 0.12 CFM/SQ. FOOT
	RECEIVING AREA	7.5 CFM/PER + 0.12 CFM/SQ. FOOT
	BATHROOMS	7.5 CFM/PER + 0.12 CFM/SQ. FOOT
INSIDE DESIGN TEMPERATURE	SUMMER	75TDB
	WINTER	72TDB
OUTSIDE DESIGN TEMPERATURE	SUMMER	96°F DB , 76°F WB
	WINTER	24°F DB
LIGHTING LOAD ALLOWANCE	2 WATTS/SQ.FT.	

### LEGEND

SYMBOL	DESCRIPTION
	SUPPLY DIFFUSER
	RETURN/EXHAUST GRILLE
	THERMOSTATIC SENSOR
	RUNOUT (FLEX. DUCT NOT ALLOWED)
	ACOUSTICALLY LINED DUCTWORK
	SIDE TAKE OFF FITTING W/ MANUAL VOLUME DAMPER
	DIFFUSER TAG NECK SIZE CFM
RTU	ROOF TOP UNIT
EF	EXHAUST FAN
O.A.	OUTSIDE AIR
	SMOKE DETECTOR

### HVAC NOTES

- DO NOT SCALE DRAWINGS. ROUGH FROM ARCHITECTURAL DRAWINGS AND EQUIPMENT MANUFACTURER'S CERTIFIED DRAWINGS. SEE ARCHITECTURAL DRAWINGS FOR EXACT DIMENSIONS, FIXTURE LOCATIONS, ETC.
- DIMENSIONS ARE IN INCHES UNLESS OTHERWISE NOTED.
- UNLESS OTHERWISE SHOWN OR NOTED, LOCAL ALL PIPING ABOVE CEILING.
- WHEREVER THE WORD "PROVIDE" IS USED, IT SHALL MEAN "FURNISH AND INSTALL COMPLETE AND READY FOR USE."
- WHERE NOTED, LOCATE ABOVE CEILING.
- WHERE NOTED, RISE OR DROP IN WALL.
- PROVIDE "P" TRAP FOR ALL CONDENSATE DRAINS AND SAFETY DRAINS. PROVIDE INSULATED DRAIN LINES FROM ALL DRAIN CONNECTIONS TO DRAINAGE SYSTEM.
- CONSTRUCT DUCTWORK AS JOB PROGRESSES AND AFTER COORDINATING WITH ALL CONCERNED TRADES AND CONTRACTORS.
- WHERE DUCTS PASS OVER RECESSED LIGHTING, MAINTAIN 7" CLEARANCE FROM CEILING TO BOTTOM OF DUCT.
- CEILING DIFFUSERS ARE 4-WAY UNLESS OTHERWISE NOTED.
- PITCH FOR CONDENSATE LINES SHALL BE CONSTANT WITHOUT SAGS OR DIPS AND SHALL MAINTAIN A RATE OF FALL OF AT LEAST 1/8" PER FOOT. ARRANGE FITTINGS TO PROVIDE MINIMUM FRICTION.
- ELECTRICAL CHARACTERISTICS SHOWN ON SCHEDULES OR DRAWINGS ARE DESIGN VALUES ONLY AND SHALL BE VERIFIED BEFORE ORDERING EQUIPMENT.
- DUCT SIZES SHOWN ON PLANS ARE CLEAR INSIDE DIMENSIONS. INCREASE DUCT SIZE AS REQUIRED TO ACCOMMODATE DUCT LINER. SEE SPECS.
- WHEN EARTHQUAKE LOADS ARE APPLICABLE ACCORDING TO THE REQUIREMENTS OF THE INTERNATIONAL BUILDING CODE, ALL MECHANICAL ATTACHMENT DEVICES SHALL BE IN STRICT ACCORDANCE WITH THE 2012 INTERNATIONAL MECHANICAL CODE, SECTION 301.16.

**VISTA ENGINEERING, PLLC**  
CONSULTING MECHANICAL ENGINEERING  
530 S. SALUDA AVE. COLUMBIA, SC 29205  
TEL: (803) 799-8900 FAX: (803) 799-8960  
E-MAIL: rcottrell@vistaengineering.net

JOHN P. WATKINS, ARCHITECT  
56 HILLMARK DRIVE  
COLUMBIA, SOUTH CAROLINA 29210

**Craig A. Otto**  
ARCHITECT, INC.

DESIGN • PLANNING • ARCHITECTURE

5044 Augusta Road  
Lexington, South Carolina 29072  
Phone (803) 957-9004  
Fax (803) 957-2050

No.	Revisions	Date

All rights reserved. This drawing and the design shown thereon are copyrighted as prescribed by the laws of the United States and are the sole property of Craig A. Otto, Architect, Inc. Anyone duplicating, reproducing, or causing to be reproduced these drawings or the design thereon without permission of the architect will be subject to legal action.

Project Title DOLLAR GENERAL #23725  
US 421 S, LILLINGTON, NC

Drawing Title  
HVAC SCHEDULES, DETAILS

Consultant  
VISTA ENGINEERING, LLC

Seal 	Signature <i>Craig A. Otto</i>	Date DECEMBER 8, 2021
Drawn By COTTRELL	Drawing No. <b>M2.1</b>	12.08.2021

## HVAC SPECIFICATIONS - GENERAL

### SCOPE

Drawings and specifications are complementary and what is called for by either shall be as binding as if called for by both. Provide all supervision, labor, material, equipment, machinery, plant and any other items necessary for a complete, safe and quietly operating HVAC, plumbing and fire protection systems. Provide accessories in accordance with manufacturer's recommendations for the conditions encountered. Examine other drawings and specifications and bring to attention of Architect prior to bid time any omissions, errors, or discrepancies in this Division. Work includes the study of all contract documents, the preparation of shop drawings, and coordination with other trades as necessary to install the systems. Systems are to be installed as close to details of contract documents as possible. Submit complete layout shop drawings for all work for review unless otherwise provided.

### CODES, RULES, PERMITS AND FEES

Permits, fees, including all sanitary sewer and/or water tapping fees, etc. are included. Comply with all City, County, and State applicable laws, ordinances, codes, rules and regulations. Deliver certificates and permits to Architect. All material and work shall comply with the National Fire Codes of the NFPA, National and local codes. Deliver to Architect, permits and licenses including certificates from local and State Health Departments, approving complete sanitary sewer and water systems.

### DRAWINGS

Drawings are schematic and indicate only the general arrangement of systems and work included in the contract. Provide all offsets, fittings, etc., without extra charge.

### DAMAGES

Cost of repairing damage to building, building contents, and site during construction and guarantee period resulting from this work is a part of this contract.

### FINISHED PLANS

Indicate in red ink on prints, all approved changes to underground services. Submit print along with other submittals required prior to substantial completion.

### MANUFACTURERS INSTRUCTIONS AND RECOMMENDATIONS

Prior to purchasing equipment procure product manufacturers' recommendations, application, installation and operating instructions for use in conjunction with the system design drawings and specifications during construction. If there exists any conflict between the manufacturers' publications and the design drawings and specifications, immediately notify the Engineer, in writing. Upon notification by the Engineer, proceed in accordance with his/her instructions. Where standard printed information is not available or applicable, the written recommendations of a manufacturer's representative (who has authority to represent the manufacturer) shall be obtained. All printed recommendations shall be kept in a folder on the job site, shall be made available to the Architect/Engineer when requested, and shall be turned over to the Architect before the final project visit.

### ELECTRICAL CONNECTIONS

In general electrical characteristics of equipments are not indicated on drawings and or specifications. VERIFY ACTUAL ELECTRICAL CHARACTERISTICS TO BE USED ON PROJECT BEFORE BIDDING OR PREPARING SHOP DRAWINGS AND OR ORDERING EQUIPMENT. If electrical characteristics are indicated on drawings or in specifications they are equipment selection values only and shall not be used for ordering equipment. All motors shall be protected with magnetic starters or with built-in thermal overload protection. Provide starters with "Hand-off-Auto" switch. Provide overload protection in all phases. The electrical contractor shall provide all wiring except: temperature control wiring, equipment control wiring, and interlock wiring. The electrical contractor shall furnish and install all power wiring complete from power source to motor or equipment junction box, including power wiring thru starters. Electrical contractor shall install all starters not factory mounted on equipment. This contractor shall, regardless of voltage, provide all temperature control wiring, all interlock wiring, and equipment control wiring for equipment provided under this Division. This contractor shall furnish all starters and contactors to the electrical contractor. This contractor shall provide and be responsible for overload heaters in all starters furnished. Starters shall be provided with a heater in each ungrounded conductor. The electrical contractor shall furnish all duct smoke detectors. This contractor shall install duct smoke detectors and shall wire smoke detectors to shut down fan(s).

### SHOP DRAWINGS

The Engineer will review and take appropriate action on shop drawings, product data, samples, and other submittals required by the Contract Documents. Such review shall be only for general compliance with the design and with the information given in the Contract Documents. It shall not include review of quantities, dimensions, weights, fabrication processes, construction methods, coordination with the work of other trades, or construction safety precautions, all of which are the sole responsibility of the Contractor. Engineer's review shall be conducted with reasonable promptness consistent with sound professional practice. Review of a specific item shall not indicate acceptance of an assembly of which the item is a component. The Engineer shall not be required to review and shall not be responsible for any deviations from the Contract Documents not clearly noted by the Contractor, nor shall the Engineer be required to review partial submissions or those for which submissions for correlated items have not been made. PRIOR TO SUBMITTAL OF SHOP DRAWINGS TO THE ENGINEER, THE CONTRACTOR SHALL REVIEW AND APPROVE SHOP DRAWINGS. SHOP DRAWINGS WHICH HAVE NOT BEEN REVIEWED AND APPROVED IN WRITING BY THE CONTRACTOR WILL NOT BE REVIEWED BY THE ENGINEER. Contractor shall state in writing on shop drawings, any proposed deviations from contract documents. Such deviations, if not stated in shop drawings submittal, shall be the sole responsibility of the Contractor.

This contractor shall submit for review by the Engineer detailed shop drawings of all equipment and all material. Submittals shall be legible. Illegible copies and or faxes will not be accepted. All submittal data shall be submitted at one time and shall be bound in a hardback binder. Partial submittals will not be reviewed by the Engineer. No material or equipment for which Engineer's review is required shall be delivered to the job site or installed until this contractor has in his/her possession the reviewed shop drawings for the particular material or equipment. The shop drawings shall be complete as described herein. This contractor shall furnish the number of copies specified by the Architect or six (6) copies of shop drawings if no number is specified by the Architect. Shop drawings submitted for review shall be detailed, dimensioned drawings or catalog pages showing construction, size, arrangement, operating clearances, performance characteristics and capacity. Samples, drawings, specifications, catalogs, submitted for review shall be properly labeled indicating specific service for which material or equipment is to be used, section and article number of specifications governing, contractor's name, and name of job. Catalogs, pamphlets, or other documents submitted to describe items on which review is being requested, shall be specific and identification in catalog, pamphlet, etc. of item submitted shall be clearly made in ink. Data of a general nature will not be accepted. Layout Drawings: The Contractor shall make layout shop drawings for work that is to be installed under this Division of the Contract. Layout drawings shall be based on the study of all contract documents and actual on-site conditions when applicable. The Contractor shall be responsible for all dimensions and space conditions. Layout drawings shall include plans, elevations, and sections as required to clearly define installation details. Coordinate with manufacturer's recommendations, building construction details, and other trades. Show layouts of equipment, indicating adequate clearance for operation, maintenance, and replacement of operating equipment devices. Review rendered on shop drawings shall not be considered as a guarantee of measurements of building conditions. WHERE DRAWINGS ARE REVIEWED, SAID REVIEW DOES NOT MEAN THAT DRAWINGS HAVE BEEN CHECKED IN DETAIL; SAID REVIEW DOES NOT IN ANY WAY RELIEVE THIS CONTRACTOR FROM HIS/HER RESPONSIBILITY OR NECESSITY OF FURNISHING MATERIAL OR PERFORMING WORK AS REQUIRED BY THE CONTRACT DRAWINGS AND SPECIFICATIONS. Failure of contractor to submit shop drawings in time for review by Engineer with reasonable promptness consistent with sound professional practice shall not entitle him/her to an extension of contract time, and no claim for extension by reason of such default will be allowed.

### OR EQUAL

Specific reference in the specifications to any article, device, product, materials, fixture, form or type of construction, etc., by name, make, or catalog number, with or without the words "or equal," shall be interpreted as establishing a standard of quality and shall not be construed as limiting competition and the Contractor in such cases may, at his/her option, use any article, device, product, material, fixture, form or type of construction which, in the judgment of the Architect/Engineer expressed in writing, is equal to that named. Where quality and other characteristics are very nearly the same, the question of determining equal materials and readily available service sometimes resolves itself to a matter of personal opinion and judgment and in these and all other cases involving the approval of materials, the opinion, judgment, and decision of the Architect/Engineer and the Owner shall be final and bind all parties concerned.

### REQUESTS FOR SUBSTITUTION

Written requests to substitute materials or equipment considered by the Contractor as equal to those specified must have been submitted ten (10) calendar days prior to bid opening date to the Architect/Engineer. Requests must have been accompanied by samples, descriptive literature, and engineering information as necessary to fully identify and allow appraisal of the product. Requests must have been made in writing. Substitution requests that are approved by the A/E will be acknowledged in a written addendum; substitution requests that are not approved may not be acknowledged in a written addendum. No substitutions will be allowed, nor will an increase in Contract be allowed (for using materials specified) if substitutions have been requested later than ten (10) days prior to bid opening date. Requests for substitutions shall be submitted in the form of a letter (with one copy minimum) on letterhead of submitting firm. Letter shall be addressed to the Engineer and referenced to this job. Proof shall be provided to indicate that the manufacturer has fabricated units of the approximate capacity specified which have seen two years satisfactory service. Items of equipment shall be supported by a service organization that is, in the opinion of the engineer, reasonably convenient to the site. If there are no deviations between the items submitted and the items shown on the drawings and specifications, then the submittal letter shall contain the statement, "Items are in accordance with drawings and specifications with no deviations." An item with deviations from the drawings and specifications may be submitted for consideration. Letter should then state, "Item submitted is in accordance with drawings and specifications, except for the following deviations:" Deviations should then be listed in itemized form. Items to which the Engineer has given an "OK" to quote shall not be construed as authorizing any deviations from the plans and specifications. This Contractor shall be responsible for verifying all dimensions with available space conditions with provisions for proper access, maintenance, and part replacement, and for coordination with other trades - electrical, plumbing, structural, etc. for proper service and construction requirements. If a substituted item requires a different quantity and arrangement of ductwork, piping, structural supports, insulation, controllers, motors, starters, electrical wiring and conduit, and any other additional equipment required by the system, such equipment shall be provided at no additional cost to the Owner.

### INSTRUCTIONS

Provide three complete Instruction Manuals. Each manual shall be a hardback three-ring binder containing all warranties, catalog data and the manufacturer's standard operating and maintenance instructions for each item of equipment. Manufacturer's data shall be edited as required so that information is applicable only to equipment installed on this project. Binder shall also contain maintenance checklists, start-up reports, testing and balancing reports, statement of completion, control system certification, and all other reports and certificates specified. Each binder shall also contain a maintenance sheet for each piece of equipment, typewritten by this contractor. Each sheet shall list the maintenance functions to be performed in accordance with the manufacturer's recommendations and the frequency with which each is to be done. Each sheet shall be initialed by the manufacturer's agent as being correct. Provide columns on each sheet so that they may be dated by maintenance personnel when each individual function is performed. Prior to substantial completion site visit and punch list this contractor shall instruct the Owner's representative in complete detail as to the proper operation and care of the overall system, and obtain a letter from the Owner stating that s/he has been satisfactorily trained in the overall operation and care of the HVAC and/or plumbing system(s). Advise the Owner as to where to order common replacement items. Deliver to the Owner the manufacturer's agent's name, address, and telephone number for each piece of equipment.

### SUBSTANTIAL COMPLETION

Prior to substantial completion of this project, the following shall be complete: Preparation and submittal to Architect/Engineer of a list of items to be completed or corrected. Instruction Manual including owner training and letter referenced above. Maintenance Checklists Start-Up Reports Record Drawings Testing, Adjusting and Balancing Statement of Completion Control System Certification

### WARRANTIES

Contractor shall correct defects in workmanship, materials, equipment, and operation of the systems. This does not supersede manufacturer's warranties, which may extend beyond one year. All refrigeration compressors shall have the manufacturers standard 5 year parts warranty. Contractor warrants that the systems installed will safely, quietly, and efficiently accomplish its intended function in accordance with the design. Replacement filters will be furnished by the Owner.

### FINISHES

Finishes for all water coolers, grilles, registers, diffusers, room fan coil units, room air conditioning units, louvers, and any other items exposed to view shall be selected by Architect and shall be equivalent to baked enamel. Submit color charts along with submittal data.

### SITE CONDITIONS

All bidders shall visit the site of the work and become familiar with all existing conditions before submitting a bid. Submission of a bid will be considered as evidence that this has been done, and no extra payments will be allowed this contractor because of extra work made necessary by his/her failure to do so.

### UTILITY INTERRUPTIONS

Obtain Owner's approval for water and/or sewer utility interruptions at least five working days in advance of all scheduled interruptions. Contractor shall arrange work so that interruptions are minimized in number and duration.

### MATERIAL AND EQUIPMENT

All material and equipment shall be new and shall be without defects.

### IDENTIFICATION AND NAMEPLATES

Scope: All piping, valves, controls and equipment on this project shall be identified as specified herein. All marks of identification shall be easily visible from the floor or usual point of vision. All equipment, except in finished areas, shall have nameplates identifying the piece of equipment by name and numerical sequence relative to other equipment. Example: AH-1, AH-2, etc. OBTAIN OWNER'S APPROVAL OF ACTUAL NUMBERING SEQUENCE PRIOR TO HAVING NAMEPLATES MADE AND INSTALLED.

### FOUNDATIONS AND SUPPORTS

Provide all necessary foundations, supports, pads, bases and piers required for all air conditioning equipment, piping, pumps, and for all other equipment furnished under this contract. For pumps, and other rotating machinery, and for all equipment where foundations are indicated, furnish and install concrete pads as shown. All pads shall be extended 6" beyond machine base in all directions with top edge chamfered. Inset 6" steel dowel rods into floors to anchor pads.

### PAINTING AND COLOR CODING

All new equipment, piping and materials exposed to view shall be painted as required except equipment furnished with factory-painted finishes. All new equipment and materials shall be completely sanded, primed and repainted where factory-paint has been scratched. Paint shall be as recommended by equipment manufacturer. Paint all supports, hangers, angles, and all other unpainted metal with two coats of high heat aluminum paint. Pipes shall be color coded with colors selected by the Engineer. Submit color samples to Engineer before application. Devoe, Sherwin Williams, Pittsburg or Glidden.

### WORKMANSHIP

Workmen shall be thoroughly experienced and fully capable of installing assigned work. Work shall be in accordance with the best practice of the trade, as recommended by the manufacturer and/or as approved by the Engineer. Work that is not of good quality in the opinion of the Engineer shall be removed and reinstalled. An experienced superintendent shall be continuously in attendance on the job during all phases of construction of the building, to coordinate and supervise the work.

### COORDINATION

Prior to starting work, coordinate with all other trades and building features to avoid interferences and establish necessary space requirements and tie-ins for each trade. Prior to starting installation, furnish to the General Contractor and all contractors concerned, copies of layout shop drawings and approved shop drawings showing location of equipment, piping, etc. Schedule periodic meetings with other trades before and during installation to avoid conflicts and assure that pipes and equipment are installed in the best manner, taking into consideration headroom, maintenance, appearance, replacement and space requirements. No work shall be performed on this project before coordinating all space requirements for ducts, pipes, conduits, etc. with all contractors concerned.

### DIVISION OF WORK

Locate and provide all holes and sleeves required for the installation of the materials installed under this Section. Any holes or sleeves not installed while floors, walls and ceilings are being constructed shall be cut and patched by this Contractor under the supervision of the General Contractor. This Contractor shall furnish roof curbs. Curbs shall be installed and flashed by the General Contractor. Refer to electrical and control subsection of this specification for work contained therein.

### CUTTING AND PATCHING

Provide all cutting and patching necessary to install the work specified in this Section. Patching shall match adjacent surfaces. Lay out work in advance and establish location of chases, inserts, sleeves, access panels, etc. Provide inserts, sleeves, access panels, supports, etc. and check for proper installation.

### EXCAVATION AND BACKFILLING

Perform all excavation and backfilling required for work under this Division of the specifications. Install sewer and water pipes in separate trenches, graded uniformly to provide solid bearing and required fall. Dig bell holes at hubs. Remove rock for one foot below pipe and replace with sand. Upon completion of tests and inspections, backfill with approved material, placed and tamped to prevent excessive settlement.

### INSTALLATION OF MATERIAL AND EQUIPMENT

Each item of equipment and all material shall be installed in strict accordance with the respective manufacturer's recommended instructions. Obtain certified drawings and installation instructions before starting work.

JOHN P. WATKINS, ARCHITECT  
56 HILLMARK DRIVE  
COLUMBIA, SOUTH CAROLINA 29210

**Craig A. Otto**  
ARCHITECT, INC.

DESIGN • PLANNING • ARCHITECTURE

5044 Augusta Road  
Lexington, South Carolina 29072  
Phone (803) 957-9004  
Fax (803) 957-2050



No.	Revisions	Date

All rights reserved. This drawing and the design shown thereon are copyrighted as prescribed by the laws of the United States and are the sole property of Craig A. Otto, Architect, Inc. Anyone duplicating, reproducing, or causing to be reproduced these drawings or the design thereon without permission of the architect will be subject to legal action.

Project Title DOLLAR GENERAL #23725  
US 421 S, LILLINGTON, NC

Drawing Title  
HVAC SPECIFICATIONS

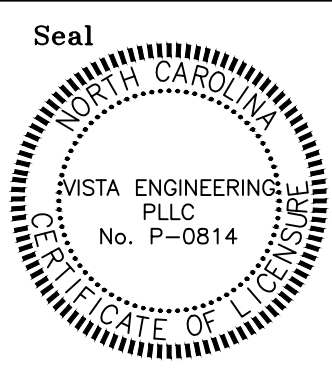
Consultant  
VISTA ENGINEERING, LLC

Seal 	<i>Craig A. Otto</i> Professional Engineer Seal No. 036304 	Date DECEMBER 8, 2021 Drawn By COTTRELL Drawing No. <u>M3.1</u> 12.08.2021
---	---	--

**VISTA**  
**ENGINEERING, LLC**

CONSULTING MECHANICAL ENGINEERING  
530 S. SALUDA AVE. COLUMBIA, SC 29205  
TEL: (803) 799-8900 FAX: (803) 799-8960  
E-MAIL: [cottrell@vistaengineering.net](mailto:cottrell@vistaengineering.net)

**PRE-CONSTRUCTION CONFERENCE**

The Contractor shall plan a pre-construction conference after s/he has thoroughly reviewed the plans, specifications, and site. Conference shall be held at the Engineer's office (or at an agreed upon location) at a time agreeable to both parties. Proposed lists of equipment to be used along with manufacturer's recommended installation details should be brought to the conference.

**CONCEALED WORK**

Unless otherwise approved, no work shall be covered or concealed without notifying the Architect or Engineer in writing at least three days in advance. Any work covered or concealed without such notice may require uncovering for examination at the Contractor's expense.

**STATEMENT OF COMPLETION**

Prior to substantial completion, Contractor shall furnish to Architect and Engineer two copies of the following statement, signed by the Contractor: Contract documents have been reviewed and construction of the mechanical systems are complete and in accordance with contract documents to the best of my knowledge, information, and belief. Mechanical systems are ready for Architect and Engineer's review.

**VEARATION ISOLATION AND SEISMIC RESTRAINT**

The work in this section consists of furnishing engineering, labor, equipment, materials, appliances, tools, permits, and in performing all operations and services necessary for and/or incidental to vibration isolation and seismic restraints and other related equipment for the subject project. Unless otherwise specified, all mechanical equipment, piping, and ductwork shall be restrained to resist seismic forces. Restraints shall maintain equipment, piping, and ductwork in a captive position. Restrain devices shall be designed and selected to meet the seismic requirements as defined in the latest issue of the 2018 International Building Code and to SMACNA Seismic Restraint Manual Guidelines for Mechanical Systems Latest Edition. The isolators and seismic restrain system shall be manufactured by Amber/Booth. Approved equal by Mason Ind., or Vibration Mountings and Controls, who meet all the requirements of the specifications are acceptable. All isolation materials, flexible connectors and seismic restraints shall be the same manufacturer and shall be selected and certified using published or factory certified data. Any variance or non-compliance with these specification requirements shall be corrected by the contractor in an approved manner. The contractor and manufacturer of the isolation and seismic equipment shall refer to the isolator and seismic restraint schedule which lists isolator types, isolator deflections and seismic restraint type.

**START UP**

Equipment listed below shall be started by a factory-trained employee of the manufacturer of the equipment. S/he shall check all phases of operation including refrigerant charge, control sequence, and operation and combustion efficiency. Submit in triplicate a signed report by factory employee stating equipment is operating satisfactorily. The following equipment shall be started by a factory-trained employee: HEAT PUMPS

**SAFETY PRECAUTIONS**

Provide all warning signs, barriers, covers, rails, belts, and other appurtenances required to protect workers, the public, and the Owner's personnel in the vicinity of the project. Comply with requirements of OSHA, municipal and insurance regulations, and reasonable standards of good practice.

**DUCTWORK**

Furnish all labor, materials, equipment, and services necessary for the installation of all supply, return, ventilation, and exhaust ductwork and related equipment and accessories as indicated on the drawings, required, and as specified.

All duct shall be in accordance with the latest recommendations of the ASHRAE Guide, with the SMACNA Duct Construction Standards, SMACNA Duct Liner Application Standard, and with details on the drawings.

All joints shall be made utilizing hard cast iron grip water duct sealant 601 or approved equal.

Materials shall be prime galvanized sheet steel free from blisters or other mechanical defects.

The general location of ducts shall be as shown. Exact location of ductwork may be altered slightly to integrate with features of the building.

Where changes are made in shape of ducts full areas shall be maintained and changes shall be gradual to minimize pressure drop.

Obstructions in ductwork shall be streamlined and shall conform to SMACNA.

Branch round ducts should enter main using spin in fittings with balancing damper by Genflex, or approved equal.

Sheet metal gauges, cross joints and reinforcing shall be as indicated by SMACNA.

The Pittsburgh lock shall be used for longitudinal seams and shall conform to SMACNA.

Elbows shall be long radius or square with single thickness turning vanes and shall conform to radius or SMACNA.

Tapers and offsets shall conform to SMACNA.

All connections between equipment and ductwork shall be made with a flexible connection consisting of a heavy glass fabric, double coated with neoprene. Material shall withstand the air pressure, 250 degrees F. temperature continuously, be fire resistant, waterproof and airtight and shall be the product of Vent Fabrics, Inc. or equal.

Hangers and supports shall conform to the latest edition of SMACNA Standards.

Hangers and supports for ductwork shall not support any other devices.

All ductwork shall be properly secured directly to the structure of the building using suitable strap or angle hangers.

All changes in direction shall either be with a radius not less than 1/2 width of the duct, or square elbow with turning vanes.

Sizes shown on drawings are inside dimensions, increase sheet metal sizes to allow for ductliner.

**DUCT ACCESSORIES**

Furnishing all labor, materials, equipment, and services necessary for the installation of all supply, return, ventilation, and exhaust ductwork accessories and related equipment and accessories as indicated on the drawings, required, and as specified.

Instrument Test Holes:

Provide test holes Ventlok 69902 or approved equal complete with gasket and heavy screw cap.

Duct Access Doors:

Provide hinged access doors with see-thru break resistant panels, Ruskin ADH3, Vent Products, or approved equal.

Door frame shall be pre-insulated internally with 1" thick 1-1/2# coated fiberglass in a 24-gauge galvanized steel casing and a 24-gauge galvanized door frame.

Frame shall be provided with a foam gasket seal between frame and duct and between frame and door.

Hinged door shall be locked with a cam lock latch.

Turning Vanes:

All square elbows shall be provided with airfoil shaped turning vanes for noise and directional control as manufactured by "Airsan" or approved equal.

Instrument Test Holes:

Test holes shall be provided at the following locations:

- Each discharge duct from air handling units.
- Each return duct to air handling units.
- Each fresh air duct to air handling units.
- Where shown on the drawings.

Duct Access Doors:

Access doors shall be located at the following installation:

- All automatic dampers in ductwork.
- All fire dampers.
- All sound attenuators.

**DUCT INSULATION**

Provide insulation as specified for supply, return, outside air and exhaust ductwork systems including accessories.

Insulation shall have a composite (insulation, jacket or facing, and adhesive) fire and smoke hazard ratings as tested by Procedure ASTM E84, NFPA 225 and/or UL 723 not exceeding:

Flame Spread	25
Smoke Developed	50

Insulation materials shall be as manufactured by Johns-Manville, CSG, or Owens Corning.

**Internal Duct Insulation:**

All supply and return rectangular sheet metal ductwork within 15 feet of the heat pump shall be insulated on the inside surfaces of the duct with 1" thickness 3 lb. density Owens/Corning Fiberglass duct liner board. All portions to receive duct liner shall be completely covered. Traverse joints shall be neatly butted and there shall be no interruptions or gaps. Board shall be cut to assure tight, overlapped corner joints. Top pieces shall be supported by the side pieces. The black surface of the duct liner board shall face the airstream. Duct liner board shall be adhered to the sheet metal duct with 100% coverage of adhesive. Adhesive shall conform to Adhesive and Sealant Council Standards for Adhesives for Duct Liner.

All exposed leading edges and traverse joints shall also be coated with adhesive. In addition to the above, mechanical fasteners shall be used to secure the duct liner board to the duct according to the following:

For horizontal runs, when the duct width or height exceeds 20", the liner shall be additionally secured with fasteners starting with 3" of the upstream traverse edges of the duct liner board and shall be spaced at a maximum of 15" o.c. and 15" from longitudinal joints. On vertical runs, the fasteners shall be used when either dimension exceeds 12". Mechanical fasteners shall conform to Mechanical Fasteners Standards available from SMACNA.

**External Duct Insulation (In addition to liner)**

All supply, return & O/A sheet metal ductwork shall be wrapped with 3" thick, flexible 3/4 lb. per foot density glass fiber insulation with reinforced foil faced, flame resistant Kraft vapor barrier. Insulation shall have a minimum installed R value of 8.0 at 75 degrees mean temperature.

Insulation shall be secured with Benjamin-Foster 85-20 adhesive. All joints shall be sealed by adhering a 2" sealing lap at all joints with BF 85-20 adhesive and stapled approximately 6" on center with outward clinching staples. Joints shall then be sealed with 3 inch Foil Scrim Kraft (FSK) tape. Where rectangular ducts are 24" or greater in width, duct wrap shall be secured to the bottom of the duct with mechanical fasteners spaced 18" on center. Insulate tops of all diffusers and boots with insulation just as supply ductwork. Entire metal surfaces to be completely covered and sealed to prevent any leakage.

**DIFFUSERS, REGISTERS, AND GRILLES**

Manufacturers: Metal-Aire, Krueger, Price, Titus, Tuttle and Bailey.

Grilles and diffusers shall be made of aluminum unless otherwise noted. OBD may be made of galvanized steel.

Finish shall be as selected by Architect, and shall be equivalent to baked enamel. Exact locations of units shall be approved before installation. Mount securely to ducts and/or building in approved manner. Maximum noise level on any unit shall not exceed 30 NC level and maximum pressure drop shall not exceed 0.08 inch. Supply units shall be adjusted to obtain approved throws and to prevent drafts.

Ceiling units shall make uniform pattern with lighting fixtures and shall be compatible with ceiling type. When indicated, provide ceiling units with throw arrangement shown. Provide air deflectors for all ceiling units.

Furnish all grilles or diffusers, other than single grille serving supply or exhaust unit, with key-operated, opposed-blade volume dampers for air balancing.

**HVAC PIPE AND PIPE FITTINGS**

Condensate Drain Piping and Fittings:

Pipe material for above ground installation shall be schedule 40 PVC with glued joints. Lay piping directly on roof to give continuous support to PVC piping. Follow roof slope to gutter as shown. Anchor piping at connection point to gutter.

Refrigerant Piping and Fittings:

System shall be complete and sized to conform to current ASHRAE standards and refrigeration equipment manufacturer's recommendations. Piping shall be type "L" hard drawn copper ACR refrigerant tubing with long radius wrought copper solder joint fittings. Joints shall be soldered with high temperature silver solder suitable for 300 psi working pressure.

Install refrigerant service valves in suction and discharge lines adjacent to the compressor unless built-in double seated valves are furnished. Refrigerant valves shall be designed for refrigerant used and shall have seal caps.

Install a three desiccant type filter drier on the inlet side of each thermostatic expansion valve. Filter driers up to ten ton capacity shall be sealed type. Filter driers for heat pump systems shall be designed for heat pump duty and shall be furnished by the heat pump manufacturer.

**LOWERS AND VENTS**

This work consists of furnishing all labor, materials, equipment, and services necessary for the installation of intake and exhaust louvers and vents for the heating, cooling, and ventilation systems as indicated on the drawings, required, and as specified.

Products principally relevant to this section include:

- Stationary Drainable Blade Wall Louvers
- Adjustable Drainable Blade Wall Louvers
- Combination Drainable Blade Wall Louvers
- Gravity Roof Ventilators
- Louvered Penthouses
- Brick Vents

All louvers and vents shall bear the AMCA Certified Ratings Seal for both air performance and water penetration. Published performance data must be submitted for approval prior to fabrication and must demonstrate pressure drop and water penetration equal to or less than model specified.

**Standards and Codes:**

Work shall be installed to conform with any City or State law, regulation, code, ordinance, ruling or Fire Underwriters requirement applicable to this class of work.

All installations for construction purposes shall conform with the Department of Labor "Safety and Health Regulations for Construction".

All equipment with electrical components shall bear the UL label.

The following minimum codes and standards apply wherever applicable:

ANSI	American National Standards Institute
ASME	American Society of Mechanical Engineers
ASTM	American Society for Testing Materials
NEC	National Electric Code
NEMA	National Electrical Manufacturers Association
NFPA	National Fire Protection Association
OSHA	Occupational Safety and Health Act
SBCCI	Southern Building Code Congress International, Inc.
SMACNA	Sheet Metal and Air Conditioning Contractors National Association, Inc.

**JOHN P. WATKINS, ARCHITECT**  
56 HILLMARK DRIVE  
COLUMBIA, SOUTH CAROLINA 29210

**Craig A. Otto**  
ARCHITECT, INC.

DESIGN • PLANNING • ARCHITECTURE

5044 Augusta Road  
Lexington, South Carolina 29072  
Phone (803) 957-9004  
Fax (803) 957-2050



No.	Revisions	Date

All rights reserved. This drawing and the design shown thereon are copyrighted as prescribed by the laws of the United States and are the sole property of Craig A. Otto, Architect, Inc. Anyone duplicating, reproducing, or causing to be reproduced these drawings or the design thereon without permission of the architect will be subject to legal action.

Project Title DOLLAR GENERAL #23725  
US 421 S, LILLINGTON, NC

Drawing Title  
HVAC SPECIFICATIONS

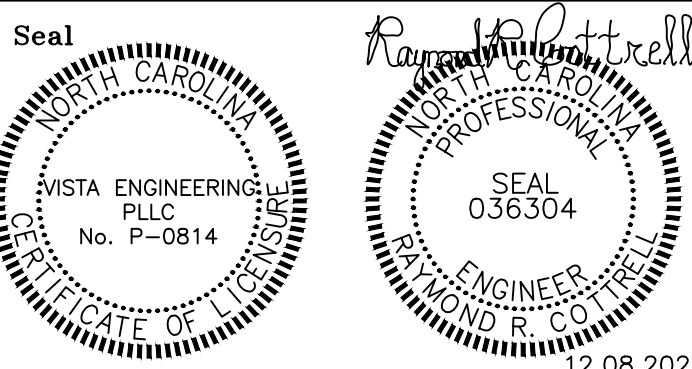
Consultant  
VISTA ENGINEERING, LLC

		Date DECEMBER 8, 2021
		Drawn By COTTRELL Drawing No. <b>M3.2</b>

**VISTA ENGINEERING, LLC**  
CONSULTING MECHANICAL ENGINEERING  
530 S. SALUDA AVE. COLUMBIA, SC 29205  
TEL: (803) 799-8900 FAX: (803) 799-8960  
E-MAIL: rcottrell@vistaengineering.net

**PROJECT CLOSEOUT:**

At the end of construction, furnish to the Architect three (3) bound and indexed sets of maintenance and operating instructions, parts lists, electrical wiring diagrams, balance data, and manufacturer's literature sufficient for operation and complete maintenance of all equipment by the Owner. Approved submittals and shop drawings may be included in the Maintenance Manuals instead of being separately furnished, if desired.

It is intended that the documentation provided in maintenance manuals, along with as-built drawings, shall be complete and detailed enough to permit and facilitate troubleshooting, engineering analysis, and design work for future changes, without extensive field investigations and testing. Manuals shall be prepared so as to explain system operation and equipment to those not acquainted with the job.

Manuals shall be durably bound and clearly identified on the front cover (and on the spine of thick volumes). Identification shall include the building or project name, applicable trade (such as HVAC, Plumbing, Fire Protection, etc.), approximate date of completion (month and year) and contractor's name.

Manuals shall be organized into well defined and easy to locate sections, with index tabs or separators to divide the sections. A complete table of contents shall be provided at the front indicating the section or page number for each system, subsystem, or supplier/manufacturer.

Manuals shall include complete information and diagrams on all controls, indicators, sensors, and signal sources. Control diagrams are to show the locations of components and major equipment by room number or other identification when room numbers are not applicable. Locations of out-of-sight components, such as duct mounted sensors, flow switches, etc. should be clearly indicated. Control diagrams must include identification of components by make and model number, operating ranges, recommended set points, reset schedules, and other job-specific data useful for troubleshooting, calibration and maintenance. Complete narrative descriptions of operating sequences of control systems and subsystems shall be included on the prints adjacent to the corresponding schematics. Catalog data and cuts shall be clearly marked to indicate model numbers, sizes, capacities, operating points, and other characteristics of each item used. This should include accessories or special features provided. Where various sizes or variations of a series or model are used, documents should clearly show which are used where. Where quantities are appropriate, schedule of usage should be provided. Maintenance literature shall include complete information for identifying and ordering replacement parts, such as illustrated parts breakdowns.

Maintenance manuals must include complete balance data on all systems.

**Instructions to Owner:**

Contractor shall conduct a maintenance and operational instruction session for the Owner. Where highly technical or complex equipment is supplied, such as chillers and control systems, manufacturer's representatives, controls subcontractors, and other appropriate personnel who are particularly qualified, shall conduct training sessions pertaining to their equipment, or systems. Such training shall be scheduled with the Owner in advance.

**EXHAUST FANS**

Fans shall be Greenheck, Penn, Cook, Carnes, Acme, ILG or approved equal. Provide fans in accordance with capacities and performance characteristics shown on the drawings.

All fans shall be furnished complete with motor and drive assemblies. All non-enclosed, exposed drives shall be furnished with factory belt guards. Furnish all accessories and hardware necessary to properly install the fan. Provide all other accessories or options as indicated on the drawing or specified herein. These may include but are not limited to disconnect switches, backdraft dampers, bird or insect screens, sound attenuating curbs, special finish or construction, and hardware shall be stainless steel.

All fans shall bear the AMCA Certified Ratings Seals for both sound and air performance.

Ceiling Exhaust Fans:

Ceiling mounted exhaust fans shall be of the centrifugal direct drive type.

The fan housing shall be constructed of heavy gauge galvanized steel with prepunched mounting brackets. The housing interior shall be lined with 1/2" acoustical insulation. The outlet duct collar shall include an aluminum backdraft damper and shall be adaptable for horizontal or vertical discharge. The access for wiring shall be external.

The motor disconnect shall be internal and of the plug type. The motor shall be mounted on vibration isolators.

The fan wheel(s) shall be of the forward curved centrifugal type, constructed of galvanized steel and dynamically balanced. Fans shall be licensed to bear the AMCA Certified Ratings Seals for sound and air performance and shall be UL listed.

Fan shall be furnished with exhaust grille for ceiling mounting.

Installation:

In general the equipment installation shall be in accordance with the manufacturer's recommendations for the specific wall or roof construction being used. Manufacturer's recommendations shall be considered a minimum and all exterior penetrations shall be properly flashed and sealed so as to be completely weatherproof and airtight.

All fans shall be balanced about their shafts and substantially vibration free.

All ducted connections to fans shall be achieved with flexible duct connectors.

Access to fan and fan parts shall be unobstructed. Provide access doors in ducts where required to access dampers for lubrication.

After installation and prior to startup all fans shall be checked for proper lubrication, belt tension, fan rotation, power supply voltage and phase, vibration isolator static deflections and controls connections.

All fans shall remain off during construction except as necessary for testing, adjustment and balancing or as directed by the Architect/Engineer. Before and after installation, air housings shall be protected from paint overspray, roofing, and other damage to the finish by wrapping the fan housing with clear plastic and temporarily taping in place.

**SINGLE ZONE PACKAGED AIR CONDITIONER**

Provide all labor, materials, equipment and services necessary for the complete installation of single zone packaged air conditioning units as indicated on the drawings and specified herein.

The unit shall be a single, draw-through packaged type, provided with specified functions and accessories, tested and rated in accordance with applicable provisions of ARI 360.

Cooling capacity of each unit shall meet the sensible and total heat requirements as indicated, at the conditions indicated.

Fan wheel shafts shall be supported by either maintenance-accessible lubricated antifriction block-type bearings, or permanently lubricated ball bearings. Unit fans shall be selected to produce the CFM air delivery required at the fan total pressure. Fan motors shall have splashproof enclosures. Motor starters shall be magnetic across-the-line type with weather resistant enclosure. Thermal overload protection shall be of manual or automatic reset type.

All fan wheels or propellers shall be constructed of aluminum or galvanized steel. Centrifugal fan wheel housings shall be of galvanized steel, and both centrifugal and propeller fan casings shall be constructed of aluminum or galvanized steel. Fan wheels and propellers shall be dynamically balanced after fabrication.

Compressors shall be hermetic scroll type capable of operating at partial load conditions, and be capable of continuous operation down to the lowest step of unloading. Each compressor shall be provided with vibration isolators, crankcase heater, thermal overloads, high and low pressure safety cutoffs and protection against short cycling.

Refrigerant-containing components shall comply with ASHRAE 15 and shall be factory tested, cleaned, dehydrated, charged and sealed. Each condenser coil connection shall be fitted with a manual isolation valve and an access valve on the coil side. Refrigerant charging valves and connections, and pumpdown valves shall be provided for each circuit.

Evaporator and condenser coils shall have copper tubes with copper or aluminum fins mechanically bonded to the tubes. Coil casings shall be galvanized steel or aluminum. Contact of dissimilar metals shall be avoided. Coils shall be tested in accordance with ASHRAE 15 at the factory and shall be suitable for the working pressure of the installed system.

Compressor shall be capable of operating in heating mode to 0 degree F outdoor air temperature.

Compressor shall have standard 5 year warranty.

All compressors shall be provided with the following minimum protection:

- a. overcurrent
- b. overtemperature
- c. short cycle with lock-out light on room thermostat
- d. high pressure relief
- e. low pressure relief
- f. liquid slugging (suction line accumulator)
- g. loss of charge

Electric resistance heaters shall be of the unit mounted type consisting of nickel chromium resistor type mounted on refractory material. Electric heaters shall meet the requirements of UL 1096 and NFPA 70 and shall be provided with high-limit thermostat interlocked electrically so that heaters cannot be energized unless the fan is energized.

Filters shall be sectional, disposable, nominal 2 inches thick and shall conform to FS F-F-310 AND UL 900, class 2.

The unit shall be internally wired with a 24 or 120 volt control circuit powered by an internal transformer. A terminal block shall be provided for power wiring and external control wiring. The unit shall be internally protected by fuses or a circuit breaker, in accordance with UL 465.

Cabinets shall be suitable for outdoor service with a weather tight, insulated and corrosion protected structure complete with roof curb. Casings shall be constructed with galvanized steel or aluminum sheet metal. Minimum thickness of exterior surfaces shall be 18 gauge galvanized steel. Insulation shall conform to ASTM C 1071.

Install equipment as shown on the drawings and in conformance with the manufacturer's written instructions. Refrigerant piping shall be sized and installed per the manufacturer's recommendations. Provide filter dryer, sight glass, and any recommended refrigeration specialties. Startup should be performed according to manufacturer's recommendations. Units should be run in cooling mode to verify operation.

**TEMPERATURE CONTROLS**

Furnish and install a complete automatic temperature control system, including all labor, equipment, materials and any incidentals required for a safe operating system. The system shall consist of, but not necessarily be limited to, all sensors, actuators, controllers, wiring, hardware, and miscellaneous materials for a complete system. The system shall be electric type, and shall be the standard catalogue product of a single manufacturer. The system shall be installed by the control manufacturer or under his direct supervision. Thermostat shall monitor both temperature and humidity and be manufactured by the same manufacturer as the equipment which it serves. Thermostat shall be programmable.

Electrical work shall be installed in accordance with the National Electric Code. All wiring, both line and low voltage, shall be installed in conduit. The control sub-contractor shall coordinate all work with the Electrical Contractor. Provide phase loss monitors to shut system down on loss of phase.

Submit complete control drawings and wiring diagrams for approval. Include all connections to equipment and interlock wiring.

Provide a framed photostatic copy of the approved control drawings, which shall reflect any changes made during construction. Provide three maintenance and operation manuals with bound therein.

After completion of the installation, adjust all control equipment and place the complete system in operation, subject to the approval of the engineer. Guarantee the complete control system to be free of defects and adequate to provide required control functions for a period of one year after acceptance of the project by the owner.

**JOHN P. WATKINS, ARCHITECT**  
56 HILLMARK DRIVE  
COLUMBIA, SOUTH CAROLINA 29210

**Craig A. Otto**  
ARCHITECT, INC.

DESIGN • PLANNING • ARCHITECTURE

5044 Augusta Road  
Lexington, South Carolina 29072  
Phone (803) 957-9004  
Fax (803) 957-2050



No.	Revisions	Date

All rights reserved. This drawing and the design shown thereon are copyrighted as prescribed by the laws of the United States and are the sole property of Craig A. Otto, Architect, Inc. Anyone duplicating, reproducing, or causing to be reproduced these drawings or the design thereon without permission of the architect will be subject to legal action.

Project Title DOLLAR GENERAL #23725  
US 421 S, LILLINGTON, NC

Drawing Title  
HVAC SPECIFICATIONS

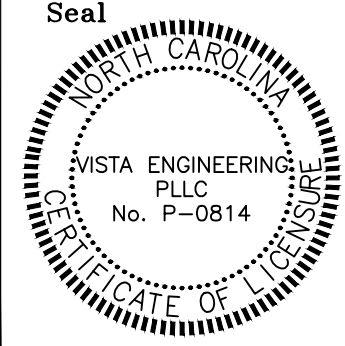
Consultant  
VISTA ENGINEERING, LLC

		Date DECEMBER 8, 2021
		Drawn By COTTRELL Drawing No. <b>M3.3</b>

12.08.2021 M3.2

**VISTA ENGINEERING, PLLC**  
CONSULTING MECHANICAL ENGINEERING  
530 S. SALUDA AVE. COLUMBIA, SC 29205  
TEL: (803) 799-8900 FAX: (803) 799-8960  
E-MAIL: rcottrell@vistaengineering.net

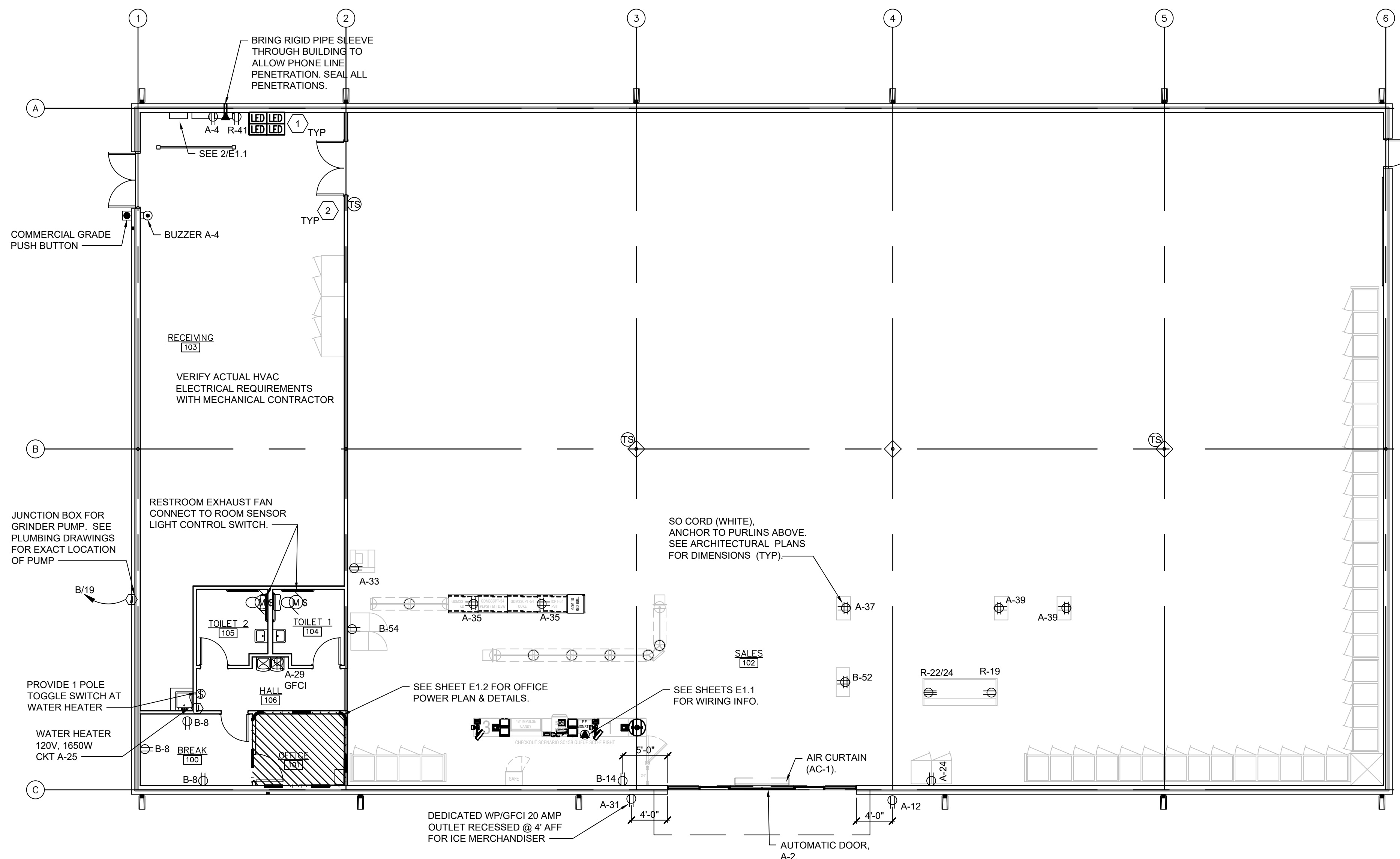

LEGEND	
SYMB	DESCRIPTION
	BUZZER - TORK MDL #TA725 W/ TRANSFORMER MDL#TA592
	COMMERCIAL GRADE PUSH BUTTON
	125V NEMA 5-20R DUPLEX. PANEL/CIRCUIT IN PANEL
	125/250V NEMA L14-20-R 4 PRONG TWIST LOCK
	125V NEMA 5-20R QUAD
	DISCONNECT
	BLACK MAGIC POWER POLE
	PHONE JACK
	RJ-11, RJ-45 DATA JACK, PHONE COMBO
	PANEL/CIRCUIT IN PANEL
	PROVIDE OCCUPANCY LIGHT SENSOR-LEVITON ODS10-IDW
	20 AMP TOGGLE SWITCH
NL	NIGHT LIGHT CIRCUIT

- ### ELECTRICAL SPECIFICATIONS
- A. ALL WIRING SHALL BE CONTAINED IN CONDUIT OF PROPER SIZE.
  - B. ALL WIRING SHALL CONFORM TO LOCAL, STATE AND FEDERAL CODES.
  - C. SERVICE IS TO BE A MINIMUM 400 AMP, 3 PHASE (PREFERRED), 600 AMP, 1 PHASE OR LARGER IF REQUIRED BY CODE OR ELECTRICAL LOAD.
  - D. REQUIRED CUSTOM BUILT POWER POLE ASSEMBLIES AVAILABLE FROM D&P CUSTOM LIGHTS & PRODUCTS INC., PHONE: (800) 251-2200 OR (615) 350-7800, 7111 COCKRILL BEND INDUSTRIAL ROAD, NASHVILLE, TN 37209. SEE E3.1.
  - E. EXTERIOR EXPOSED PHONE LINES TO BE INSTALLED IN RIGID CONDUIT. PROVIDE EMERSON 3/4" X 5-FT. METALLIC CABLE U-GUARD #755, OR EQUAL.
  - F. ELECTRICAL PANEL TO BE LABELED CORRECTLY WITH LEGIBLE PRINT.
  - G. LOW VOLTAGE VENDOR TO PROVIDE AND INSTALL ONE (1) 24 GA., 4 TWISTED-PAIR, CATEGORY-FIVE (CAT5) DATA CABLE WITH MODULAR COMBO RJ-11/RJ-45 JACK AT MANAGER'S OFFICE. CABLE TO BE RUN FROM JACK TO DATA HUB LOCATION WITH 6'-0" LEFT COILED FOR INSTALLATION TO DATA HUB. A RJ-45 MALE FITTING SHOULD BE CRIMPED ON THIS END. DOLLAR GENERAL STORE OPENING TEAM WILL MAKE FINAL CONNECTION INTO THE DATA HUB.
  - H. PROVIDE 1 1/2" EMT CONDUIT TO ACT AS ACCESS SLEEVE TO ALLOW PHONE COMPANY TO TERMINATE AT DMARC. CONTRACTOR TO PROVIDE AND INSTALL PHONE WIRING & RJ-11 PHONE JACK FOR COMPLETED WORKING SYSTEM PRIOR TO PHONE COMPANY FINAL HOOK UP.
  - I. ALL 120 VOLT OUTDOOR RECEPTACLES TO HAVE "WET LOCATION - IN USE" COVERS.
  - J. ALL CONDUCTORS TO BE COPPER, #12 AWG MINIMUM SIZE, OR AS REQUIRED BY LOAD AND OVER CURRENT PROTECTION.
  - K. SEE EMS SHEETS EMS1 AND EMS2 FOR ENERGY MANAGEMENT SYMBOLS AND INFORMATION.
  - L. ELECTRICIAN TO PROVIDE 1 1/2" CONDUIT WITH PULL STRINGS FOR SATELLITE LOCATION.
  - M. ALL POWER AND DATA TO BE ROUTED OVERHEAD. UNDER SLAB NOT ALLOWED.

- ### ELECTRICAL KEYED NOTES
- TEST/RESET STATION FOR STAND ALONE DUCT DETECTOR. ONE FOR EACH DEVICE. SEE KEY NOTE 3 ON SHEET E1.3. SIMPLEX #4098-9842 IS SPECIFIED. WITH PIEZO AND LED INDICATOR LIGHT.
  - MECHANICAL THERMOSTAT MOUNTED ON COLUMN AT 8'-0" AFF. SURFACE MOUNT BOX AND CONDUIT. STUB CONDUIT AT STRUCTURE.

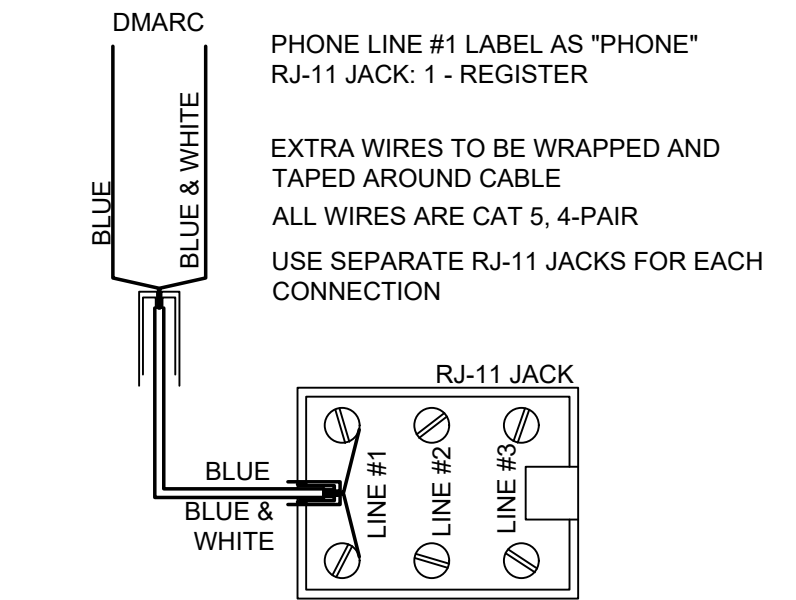

2 PHONE WIRING SCHEMATIC  
E3.1 NTS

- ### SEISMIC RESTRAINT NOTES
- A. OVERHEAD CONDUITS 2.5 INCHES AND GREATER REQUIRE SEISMIC RESTRAINT.
  - B. LIGHTING FIXTURE SUPPORTS SHOULD CONFORM TO UL 1570 OR 1571, IN ADDITION TO THE REQUIREMENTS OF FEMA 302 AND 303.
  - C. SUSPENDED TRANSFORMERS TO BE PROVIDED WITH SWAY BRACING.
  - D. WALL MOUNTED EMERGENCY LIGHTING FIXTURES TO BE SECURED TO STRUCTURE WITH REDUNDANT FASTENERS.

1 POWER PLAN  
E1.1 SCALE: 1/8" = 1'-0"

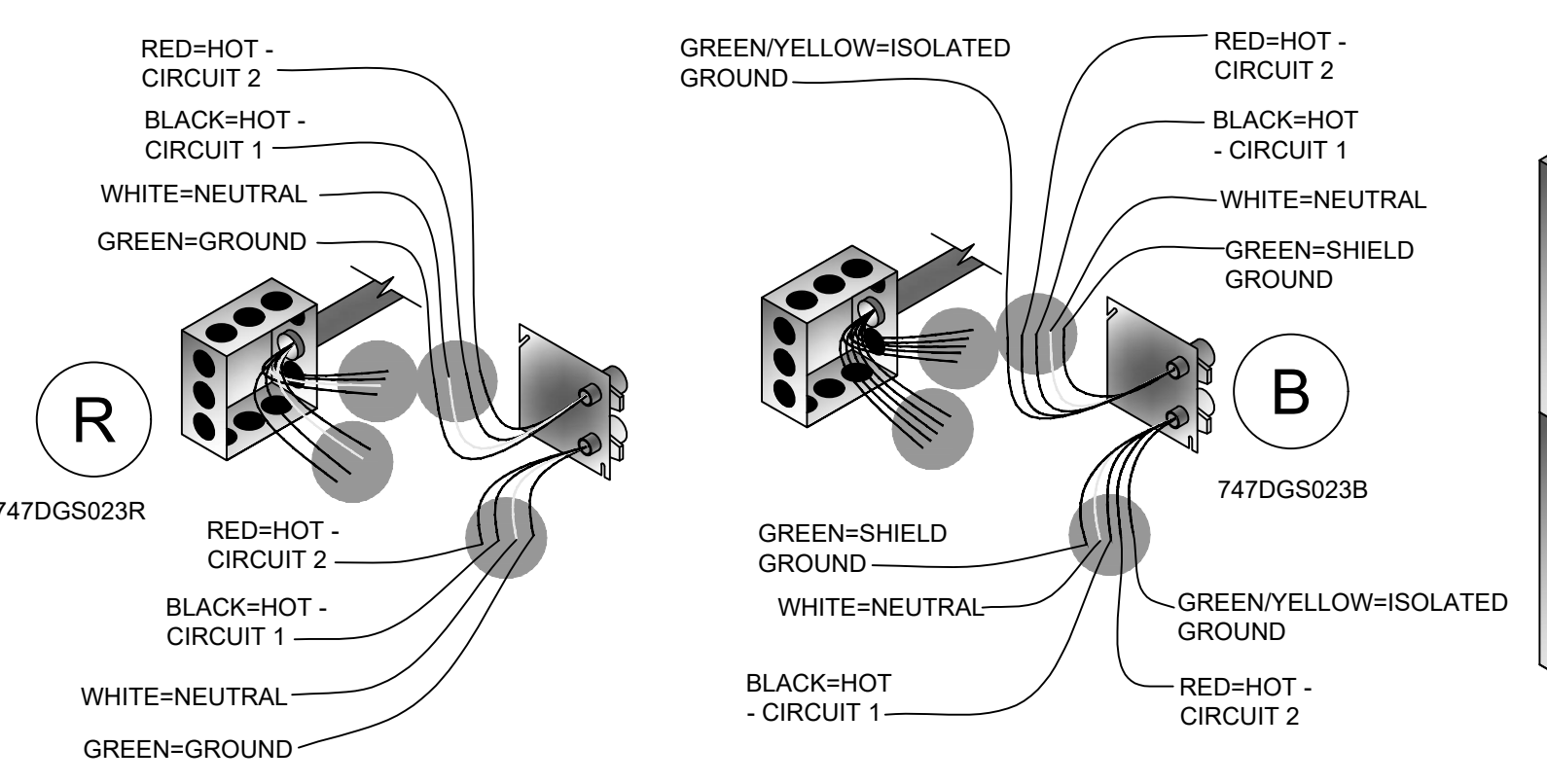

REGISTER ELECTRICAL COMPONENTS			
QTY	PART NUMBER	DESCRIPTION	VENDOR
1	747DGS023B	DUAL CIRCUIT POWER KIT WITH ISOLATED GROUND	D & P
1	747DGS023R	DUAL CIRCUIT POWER KIT	D & P
1	747DGS044-12BK	12' 2CH REGULAR POLE W/2-C & 1-D CONNECTOR DRW #2004-12	
1	747DGS032A	10' CABLE KIT (SET OF 4 WHIPS)	

\*NOTE: BEFORE ORDERING AND INSTALLATION OF ELECTRICAL COMPONENTS FOR REGISTERS, CONSULT FINAL FIXTURE PLAN FOR NUMBER AND LOCATION.  
MAXIMUM CIRCUITS FOR REGISTERS:  
• CIRCUITS AT MAIN REGISTER - (9) 110V  
• CIRCUITS AT ISLAND REGISTER - (3) 110V

4 REGISTER ELECTRICAL DETAIL  
E1.1 NTS

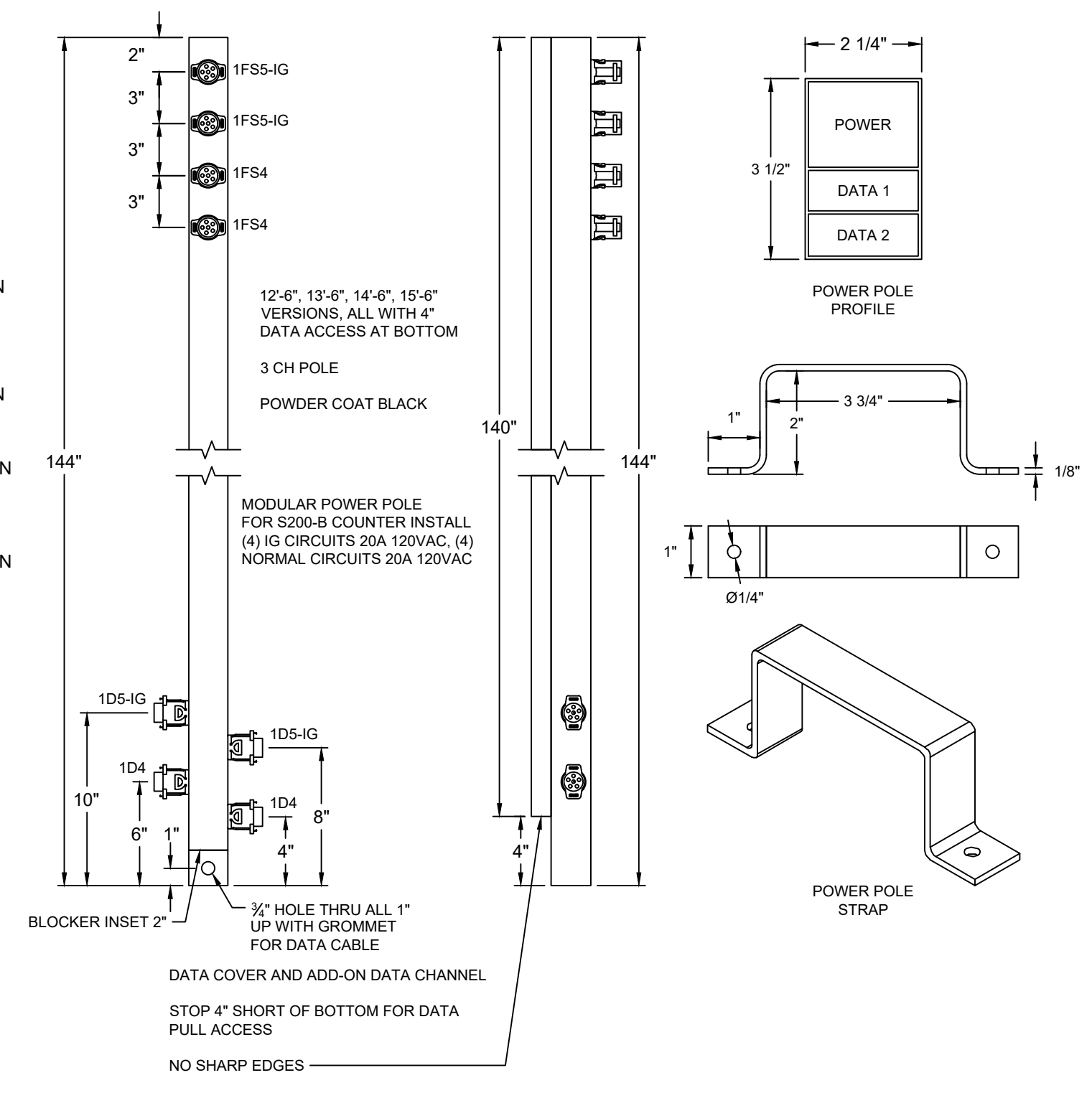

5 REGISTER POWER POLE  
E1.1 NTS

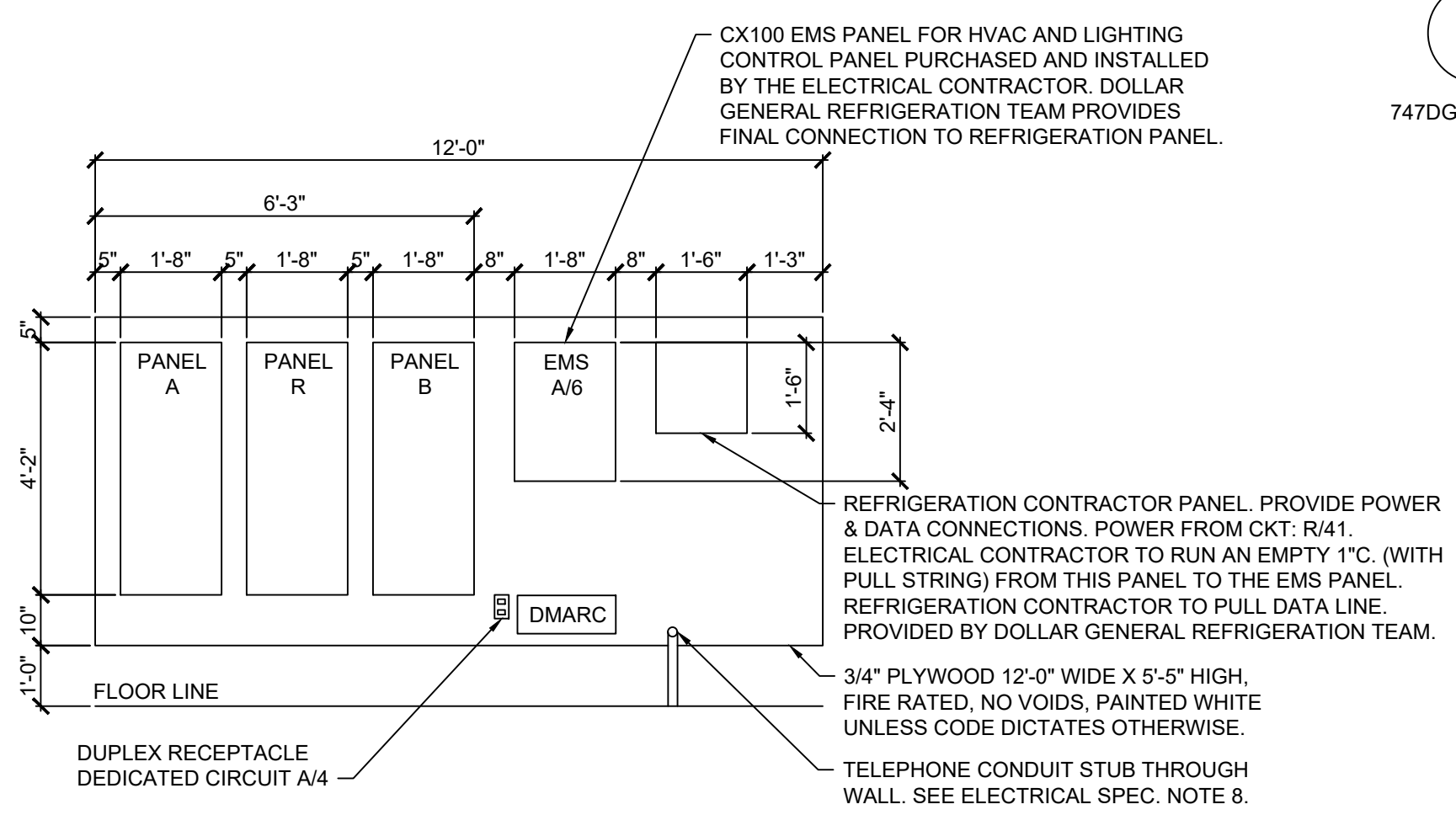

3 ELECTRICAL PANEL ELEVATION  
E1.1 SCALE: 1/8" = 1'-0"

## Craig A. Otto

### ARCHITECT, INC.

DESIGN • PLANNING • ARCHITECTURE

5044 Augusta Road  
Lexington, South Carolina 29072  
Phone (803) 957-9004  
Fax (803) 957-2050

No.	Revisions	Date

All rights reserved. This drawing and the design shown thereon are copyrighted as prescribed by the laws of the United States and are the sole property of Craig A. Otto, Architect, Inc. Anyone duplicating, reproducing, or causing to be reproduced these drawings or the design thereon without permission of the architect will be subject to legal action.

Project Title: DOLLAR GENERAL #23725  
US 421 S  
LILLINGTON, NC

Drawing Title: POWER PLAN

Consultant: **H2L** CONSULTING ENGINEERS  
116 SOUTH PLEASANTBURG DRIVE  
GREENVILLE, SC 29607  
(864) 233-8844  
www.H2L.com

Seal:

Date: 12/02/2021  
Drawn By: JCS  
Drawing No.: E1.1

H2L Project #21111 12.02.2021

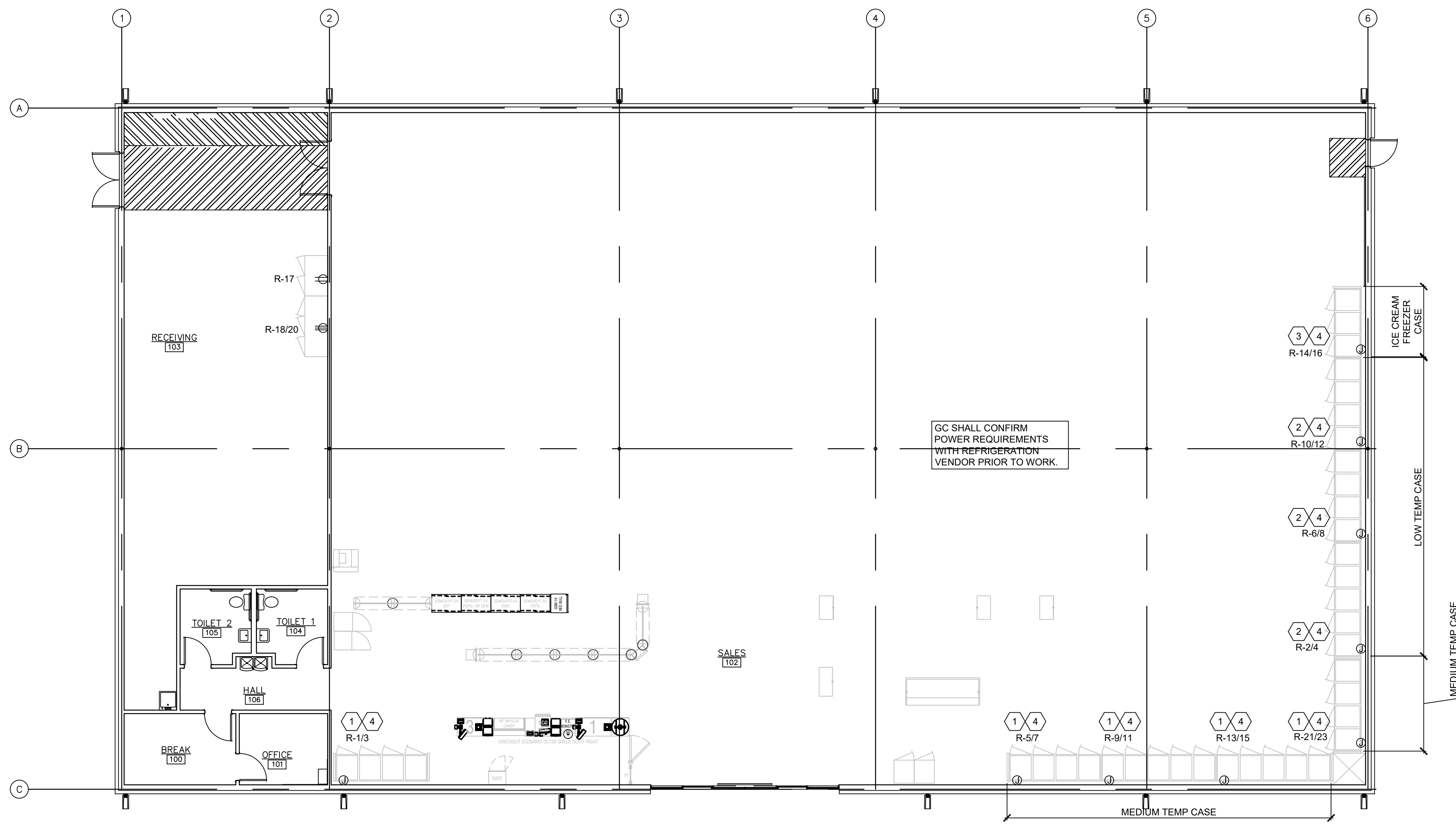

**GENERAL NOTES**

A. MOUNT ALL REFRIGERATOR OUTLETS AT 12" AFF.

- ELECTRICAL KEYED NOTES**
1. PROVIDE 208V, 1 PHASE CONNECTION TO A J-BOX AT 90° AFF WITH (3)#12 CU. & #12 GROUND IN 3/4" R.C. TO PROVIDE AND INSTALL 30A/2NF DISCONNECT SWITCH AND WIRE FROM DISCONNECT SWITCH TO EQUIPMENT CONNECTIONS.
  2. PROVIDE 208V, 1 PHASE CONNECTION TO A J-BOX AT 90° AFF WITH (3)#8 CU. & #10 GROUND IN 1" R.C. TO PROVIDE AND INSTALL 60A/2NF DISCONNECT SWITCH AND WIRE FROM DISCONNECT SWITCH TO EQUIPMENT CONNECTIONS.
  3. PROVIDE 208V, 1 PHASE CONNECTION TO A J-BOX AT 90° AFF WITH (3)#10 CU. & #10 GROUND IN 3/4" R.C. TO PROVIDE AND INSTALL 30A/2NF DISCONNECT SWITCH AND WIRE FROM DISCONNECT SWITCH TO EQUIPMENT CONNECTIONS.
  4. MOUNT J-BOX 11" FROM THE RIGHT SIDE OF EACH UNIT. CONFIRM EXACT LOCATION WITH REFRIGERATION VENDOR PRIOR TO WORK (TYP).

**LEGEND**

SYMB	DESCRIPTION
	BUZZER (TORK TA725) WITH TRANSFORMER (TORK TA592)
	COMMERCIAL GRADE PUSH BUTTON
	125V NEMA 5-15R DUPLEX
	125V NEMA 5-15R QUAD
	125/250V NEMA L14-15-R 4-PRONG TWIST-LOCK
	DISCONNECT
	BLACK MAGIC POWER POLE
	PHONE JACK AT REGISTER
	RJ-11, RJ-45 DATA JACK, PHONE COMBO AT OFFICE
	PANEL/CIRCUIT NUMBER
	20 AMP TOGGLE SWITCH
	PROVIDE OCCUPANCY LIGHT SENSOR (LEVITON ODS10-IDW)
	NIGHT LIGHT CIRCUIT

**1 REFRIGERATION POWER PLAN**  
SCALE: 1/8" = 1'-0"

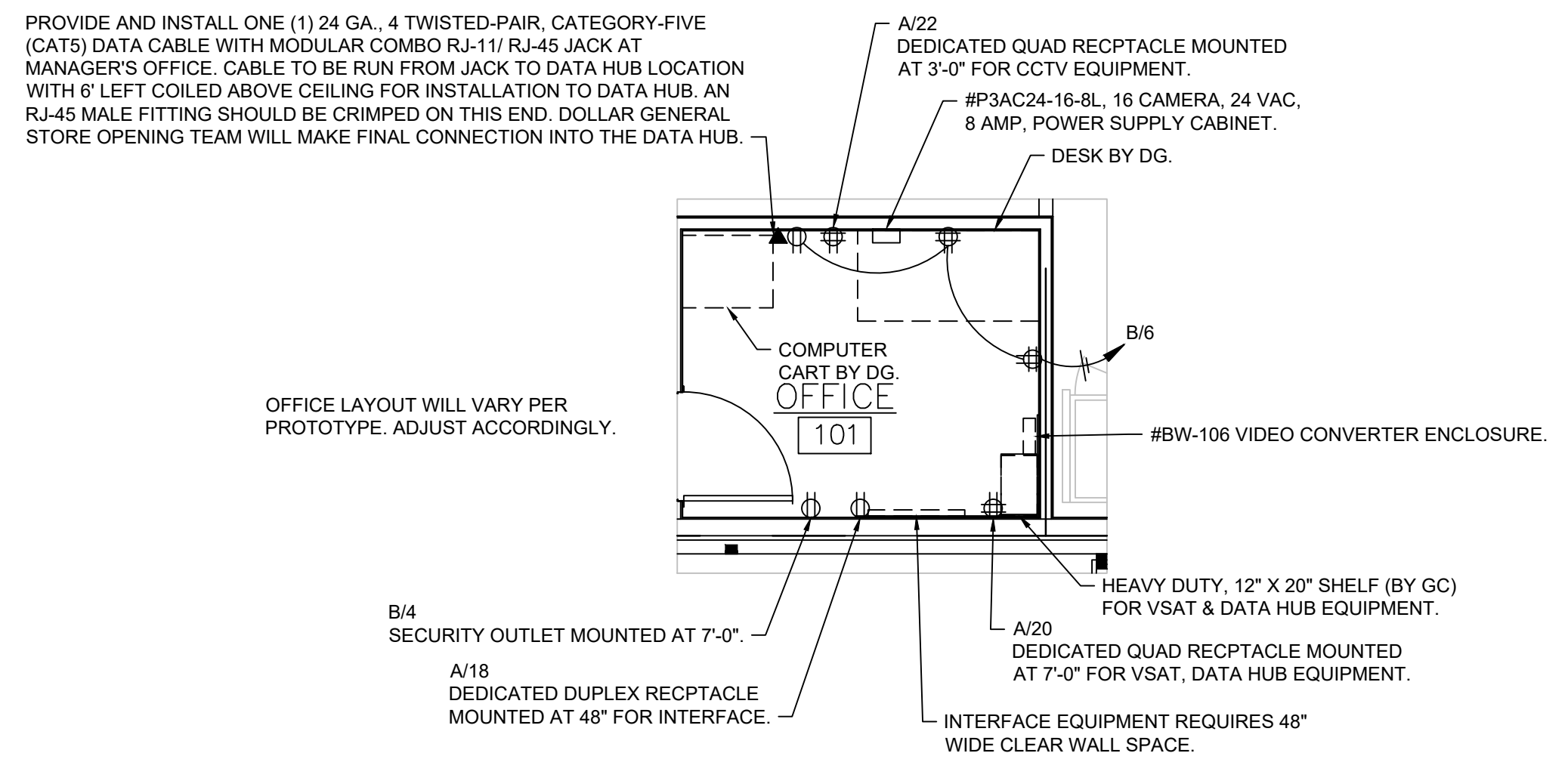

**3 LARGE SCALE OFFICE PLAN**  
SCALE: 1/4" = 1'-0"

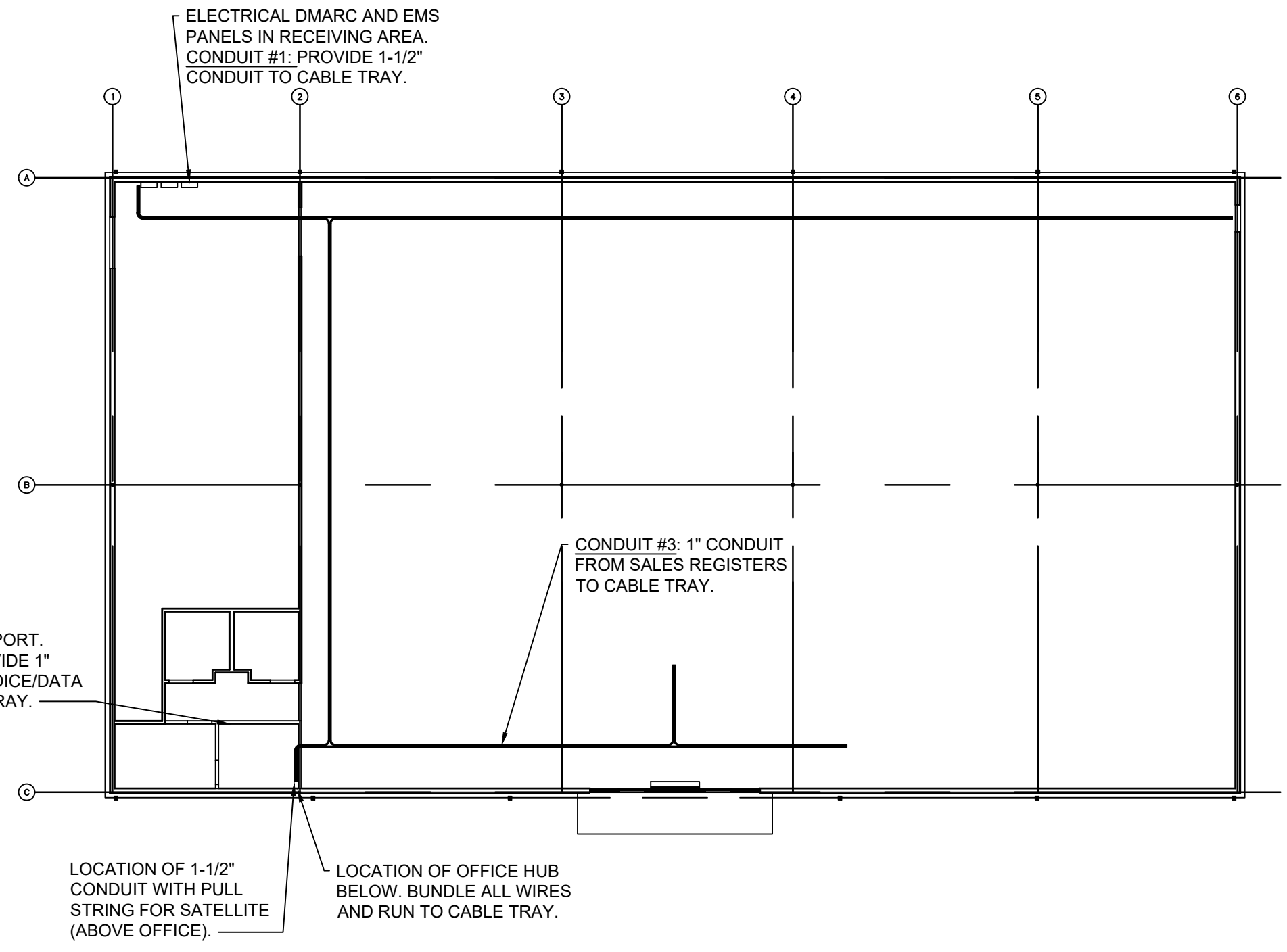

**2 CABLE TRAY PLAN AND CONDUIT DIAGRAM**  
SCALE: 1/16" = 1'-0"

**Craig A. Otto**  
ARCHITECT, INC.

DESIGN • PLANNING • ARCHITECTURE

5044 Augusta Road  
Lexington, South Carolina 29072  
Phone (803) 957-9004  
Fax (803) 957-2050

No.	Revisions	Date

All rights reserved. This drawing and the design shown thereon are copyrighted as prescribed by the laws of the United States and are the sole property of Craig A. Otto, Architect, Inc. Anyone duplicating, reproducing, or causing to be reproduced these drawings or the design thereon without permission of the architect will be subject to legal action.

Project Title: DOLLAR GENERAL #23725  
US 421 S  
LILLINGTON, NC

Drawing Title: REFRIGERATION POWER PLAN

Consultant: **H2L** CONSULTING ENGINEERS  
116 SOUTH PLEASANTBURG DRIVE  
GREENVILLE, SC 29607  
(864) 233-8844  
www.H2L.com

Seal:

Date: 12/02/2021  
Drawn By: JCS  
Drawing No.: E1.2

H2L Project #21111 12.02.2021

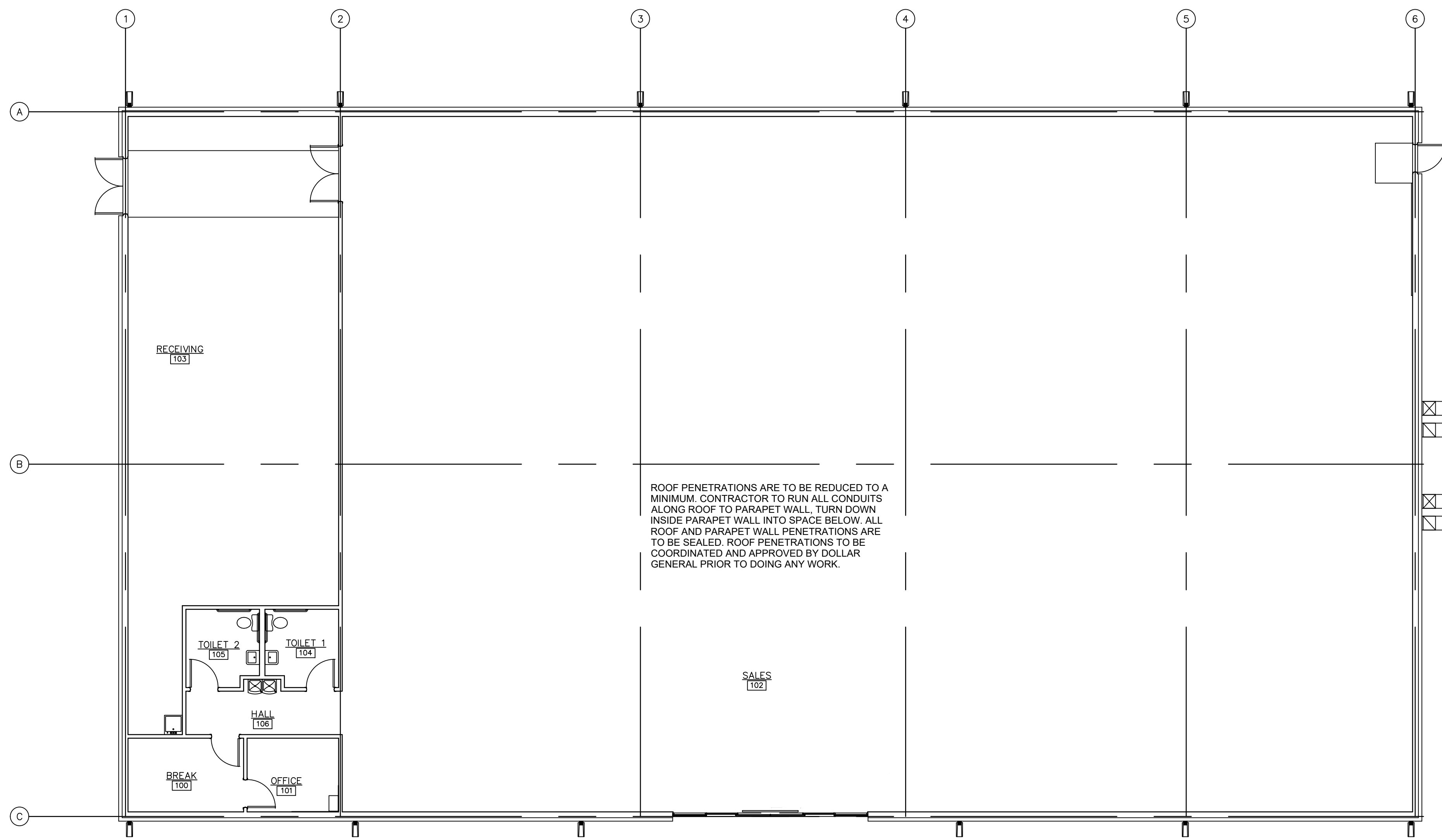

1 ROOF POWER PLAN  
E1.3 SCALE: 1/8" = 1'-0"

ROOF PENETRATIONS ARE TO BE REDUCED TO A MINIMUM. CONTRACTOR TO RUN ALL CONDUITS ALONG ROOF TO PARAPET WALL, TURN DOWN INSIDE PARAPET WALL INTO SPACE BELOW. ALL ROOF AND PARAPET WALL PENETRATIONS ARE TO BE SEALED. ROOF PENETRATIONS TO BE COORDINATED AND APPROVED BY DOLLAR GENERAL PRIOR TO DOING ANY WORK.

LEGEND	
SYMB	DESCRIPTION
	BUZZER - TORK MDL #TA725 W/ TRANSFORMER MDL#TA592
	COMMERCIAL GRADE PUSH BUTTON
	125V NEMA 5-20R DUPLEX. PANEL/CIRCUIT IN PANEL
	125/250V NEMA L14-20-R 4 PRONG TWIST LOCK
	125V NEMA 5-20R QUAD
	DISCONNECT
	BLACK MAGIC POWER POLE
	PHONE JACK
	RJ-11, RJ-45 DATA JACK, PHONE COMBO
	A-23 PANEL/CIRCUIT IN PANEL
	PROVIDE OCCUPANCY LIGHT SENSOR-LEVITON ODS10-HDW
	20 AMP TOGGLE SWITCH
	NIGHT LIGHT CIRCUIT

- ELECTRICAL KEYED NOTES**
- LOCATIONS SHOWN FOR MECHANICAL UNITS ARE ONLY APPROXIMATE, CONTRACTOR MUST CONSULT MECHANICAL OR STRUCTURAL DRAWINGS TO DETERMINE ACTUAL UNIT LOCATIONS. PROVIDE 1/2" PENETRATION THRU ROOF WITHIN FOOTPRINT OF UNIT FOR USE WITH CONTROL WIRING TO UNIT BY OTHERS. PROVIDE PROPER WATERSEAL. (TYPICAL)
  - FACTORY MOUNTED POWERED CONVENIENCE OUTLET. FIELD VERIFY THAT OUTLET IS POWERED, WIRE ALL WITH THIS NOTE TO CIRCUIT R-34 IF THEY ARE NOT POWERED.
  - PHOTOELECTRIC DUCT DETECTOR WITH HOUSING. TIE TO LED READOUT. STAND ALONE DEVICE, 120V. SIMPLEX #4098-9687 IS SPECIFIED WITH 4098-9842 CONTROL STATION. PROVIDE ONE DEVICE PER UNIT. MOUNT DEVICE IN SUPPLY AIR DUCTWORK. DEVICE SHALL BE PROVIDED AND WIRED TO THE CONTROL STATION BY THE ELECTRICAL CONTRACTOR. HIRE THE MECHANICAL CONTRACTOR FOR INSTALLATION IN DUCTWORK & CONNECTION TO SHUTDOWN CONTROLS. ELECTRICAL CONTRACTOR SHALL PROVIDE ALL REQUIRED RELAYS AND 120V POWER. DO NOT POWER DUCT DETECTORS FROM HVAC UNIT LOW VOLTAGE. PLACE ANY REQUIRED LABELING ON CEILING TILE DIRECTLY BELOW UNIT. RUN CONDUIT & WIRE UNDERGROUND FROM UNIT TO INSIDE OF SPACE.
  - MOUNT DISCONNECT SWITCH AT UNIT AS DESCRIBED IN GENERAL NOTE 1 ON THIS SHEET.

HVAC UNIT WIRING TABLE												
UNIT	WIRE	COND	DISC	FUSE	ENCL	PH	VOLT	GND	BRKR	LOAD	CFM	TONS
PAC-1	(3)#2/0	1 1/2"	200A-3P	175A	NEMA 3R	3ø	208	#6	200A-3P	62,612	6,000	15.0
PAC-2	(3)#2/0	1 1/2"	200A-3P	175A	NEMA 3R	3ø	208	#6	200A-3P	62,612	6,000	15.0
EF-1	#12	3/4"	MOTOR RATED SWITCH		NEMA 1	1ø	120	#12	20A-1P	100	125	--
EF-2	#12	3/4"	MOTOR RATED SWITCH		NEMA 1	1ø	120	#12	20A-1P	100	125	--
AC-1	#12	3/4"	MOTOR RATED SWITCH		NEMA 1	1ø	208	#12	20A-2P	500	1,800	--

TABLE NOTES:

- THE ELECTRICAL CONTRACTOR SHALL FIELD COORDINATE WITH THE MECHANICAL CONTRACTOR CONCERNING THE ELECTRICAL INFO OF ALL MECHANICAL DEVICES REQUIRING AN ELECTRICAL CONNECTION PRIOR TO DOING ANY WORK. ANY DISCREPANCIES BETWEEN THE FIELD OBTAINED INFORMATION AND THE INFORMATION SHOWN ON THE ELECTRICAL PLANS SHALL BE BROUGHT TO THE ATTENTION OF THE ENGINEER PRIOR TO DOING ANY WORK.
- PROVIDE NEUTRALS ON AS REQUIRED BASIS, FIELD VERIFY.
- ALL DISCONNECTS TO BE HEAVY DUTY. FUSES TO BE RK-5 TYPE. SUBMIT SHOP DRAWINGS. BUSSMAN FRN-R-(AMP) IS SPECIFIED.

**Craig A. Otto**  
ARCHITECT, INC.  
DESIGN • PLANNING • ARCHITECTURE

5044 Augusta Road  
Lexington, South Carolina 29072  
Phone (803) 957-9004  
Fax (803) 957-2050

No.	Revisions	Date
1	INSPECTOR COMMENTS	01/20/2022

All rights reserved. This drawing and the design shown thereon are copyrighted as prescribed by the laws of the United States and are the sole property of Craig A. Otto, Architect, Inc. Anyone duplicating, reproducing, or causing to be reproduced these drawings or the design thereon without permission of the architect will be subject to legal action.

Project Title: DOLLAR GENERAL #23725  
US 421 S  
LILLINGTON, NC

Drawing Title: ROOF POWER PLAN

Consultant: **H2L** CONSULTING ENGINEERS  
116 SOUTH PLEASANTBURG DRIVE  
GREENVILLE, SC 29607  
(864) 233-8844  
www.H2L.com

Seal:

Date: 12/02/2021  
Drawn By: JCS  
Drawing No.: E1.3

H2L Project #21111 12.02.2021



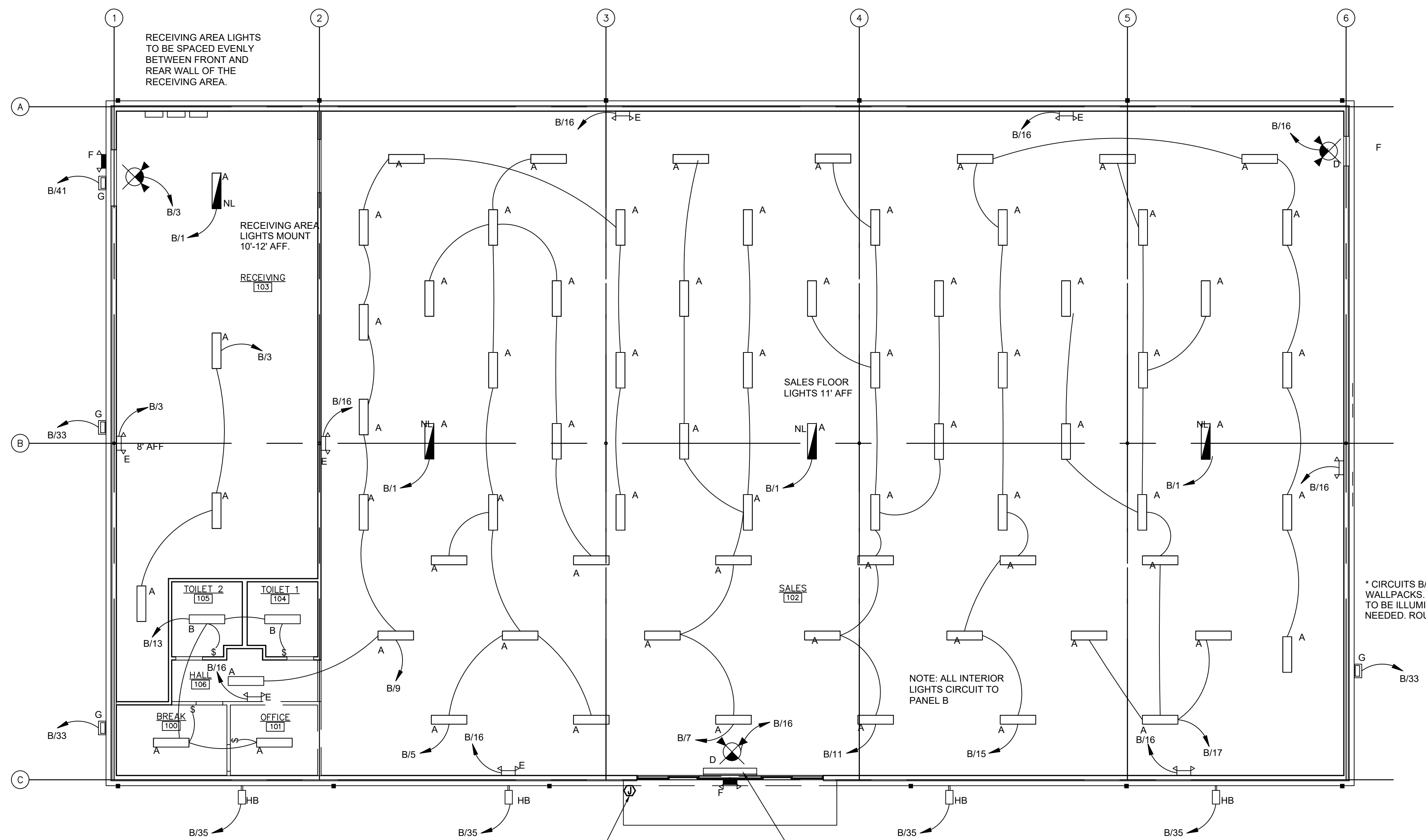

COORDINATE BUILDING SIGN SIZE WITH DOLLAR GENERAL SIGN DEPARTMENT BY EMAILING TO SIGNAGE@DOLLAR GENERAL.COM. WIRE ON CIRCUIT B/23. LOCATE BOX HIGH ON WALL 12' LEFT FROM CENTER OF BUILDING FOR 26" SIGNS & 16' LEFT FROM CENTER OF BUILDING FOR 33" SIGNS. SEE ELEVATIONS.

**1 LIGHTING PLAN**  
SCALE: 1/8" = 1'-0"  
EMERGENCY/EXIT SIGNS AND LIGHTS:  
INSTALL EMERGENCY LIGHTS & EXIT SIGNS (CENTERED AT 10'-6" AFF TO BE ABOVE FIXTURES & MERCHANDISE) THROUGHOUT THE BLDG. IN COMPLIANCE WITH ALL APPLICABLE CODES.

\* CIRCUITS B/31 AND B/33 TO BE USED FOR SIDE WALLPACKS. USUALLY ONLY ONE SIDE IS REQUIRED TO BE ILLUMINATED. USE SPARE CIRCUITS WHEN NEEDED. ROUTE THRU CONTACTOR C7 ON EMS4.AL

NOTE: ALL INTERIOR LIGHTS CIRCUIT TO PANEL B

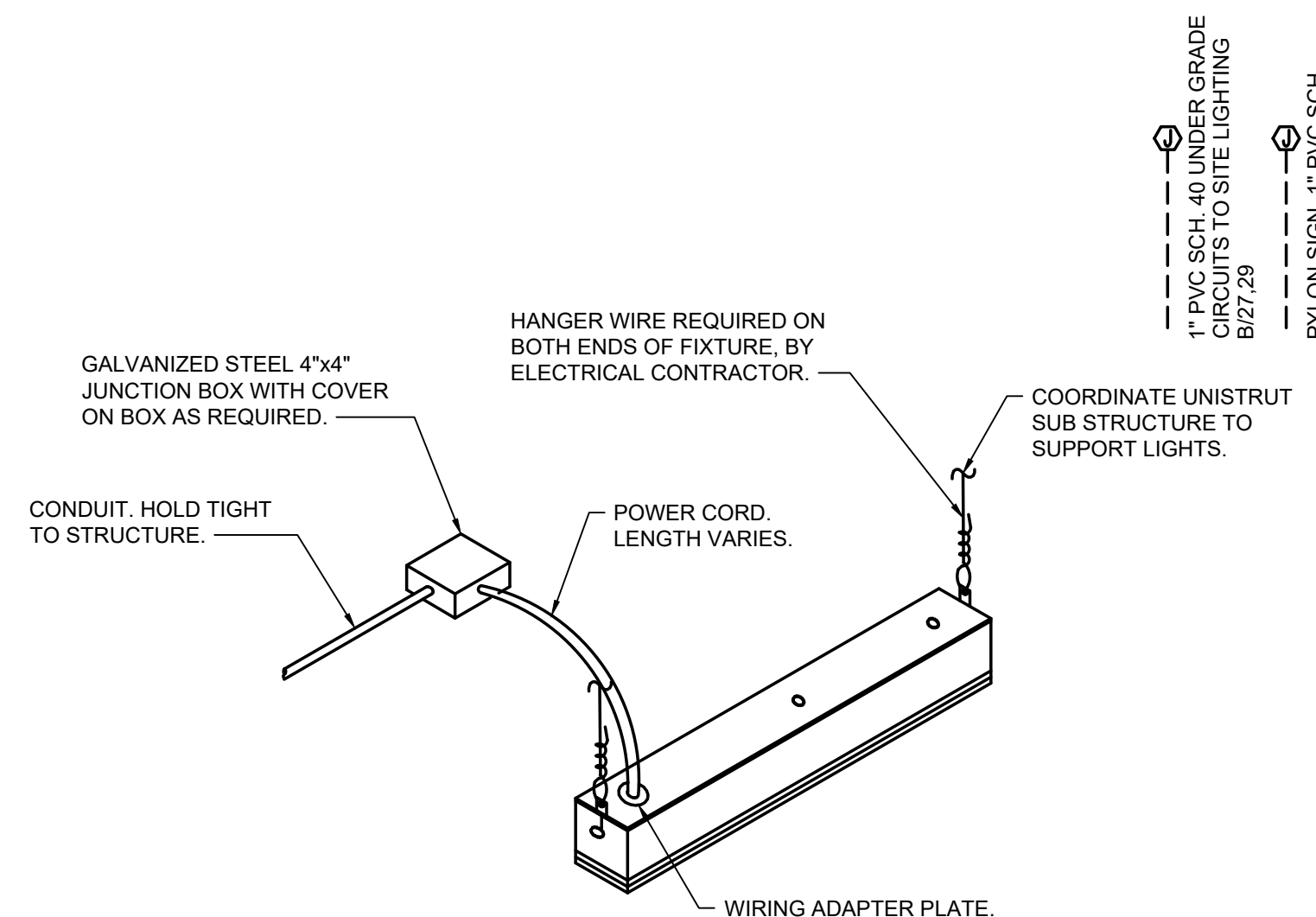

**2 TYPICAL LED FIXTURE MOUNTING DETAIL**  
SCALE: 1/8" = 1'-0"

1" PVC SCH. 40 UNDER GRADE RIGID CONDUIT TO SITE LIGHTING B/27,28  
4" PVC SCH. 40 UNDER GRADE B/23

LEDS LIGHT FIXTURE SCHEDULE					
SYMBOL	TYPE	MANF.	PART #	DESCRIPTION	W
A	A	ETI	54573161	4' LED FIXTURE AERIAL MOUNT INCLUDES (2) 8 FT CABLES	33
A1	A1	ETI B/16	54573161	4' LED FIXTURE SURFACE MOUNT	33
B	B	ETI	54260161	2' LED FIXTURE SURFACE MOUNT	20
C	C	ETI	55301101	LED EXIT SIGN	-
D	D	ETI	55502201	LED EXIT SIGN / EMERGENCY LIGHT COMBO WITH (2) HEADS	-
E	E	ETI	55501101	LED EMERGENCY LIGHT WITH (2) HEADS	-
F	F	ETI	55503101	LED EGRESS EMERGENCY LIGHT WITH (2) HEADS	-
G	TECHLIGHT		LHWP-1-C-4-T3-F1-BZ	LED WALL PACK	38
HB	TECHLIGHT		LSBT-1-C-X-T3-F1-BZ	LED AREA LIGHT	147
HP	TECHLIGHT		(2) LSBT-1-C-X-T3-F1-BZ ON SSSP-24-4-11-BZ-DM2180	(2) LED AREA LIGHTS ON 24' POLE	294

NOTE: REFER TO SHEET "T01" FOR NATIONAL ACCOUNT VENDORS LIST

**Craig A. Otto**  
ARCHITECT, INC.

DESIGN • PLANNING • ARCHITECTURE

5044 Augusta Road  
Lexington, South Carolina 29072  
Phone (803) 957-9004  
Fax (803) 957-2050

No.	Revisions	Date

All rights reserved. This drawing and the design shown thereon are copyrighted as prescribed by the laws of the United States and are the sole property of Craig A. Otto, Architect, Inc. Anyone duplicating, reproducing, or causing to be reproduced these drawings or the design thereon without permission of the architect will be subject to legal action.

Project Title: DOLLAR GENERAL #23725  
US 421 S  
LILLINGTON, NC

Drawing Title: LIGHTING PLAN

Consultant: **H2L** CONSULTING ENGINEERS  
116 SOUTH PLEASANTBURG DRIVE  
GREENVILLE, SC 29607  
(864) 233-8844  
www.H2L.com

Seal: 

Date: 12/02/2021  
Drawn By: JCS  
Drawing No.: E2

H2L Project #21111 12.02.2021

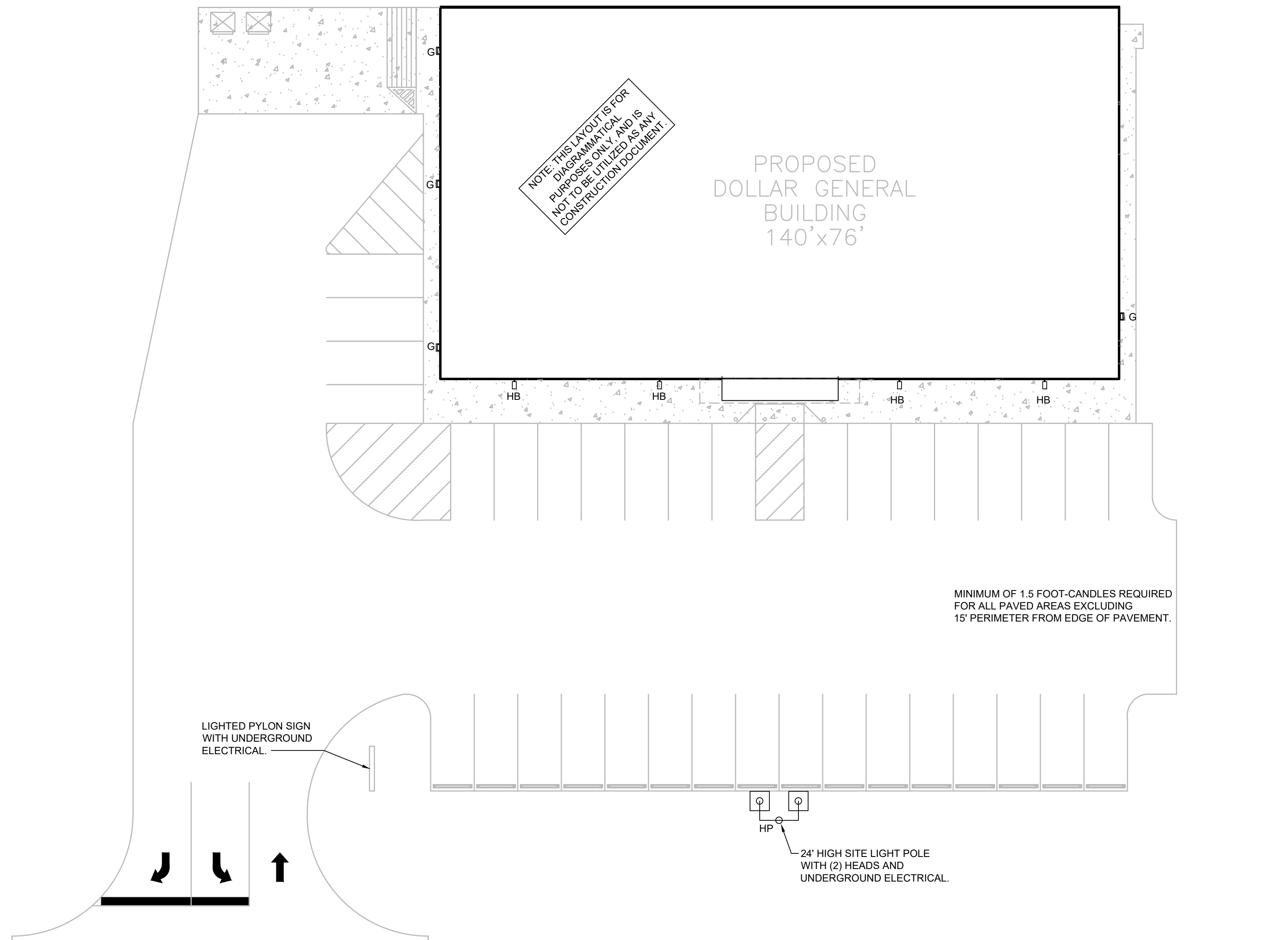

**SITE LIGHTING GENERAL NOTES**

- A. FINAL SIGN CONNECTION AND UNDERGROUND CONDUIT IS LANDLORD RESPONSIBILITY. PROVIDE CONDUIT FROM THE ELECTRICAL PANEL TO LOCATION OF THE Pylon SIGN BASE. BURY CONDUIT UNDER PARKING AREA. THE CONDUIT IS TO BE 1" AND HAVE ONE SET TO 1/2" WIRE WITH GROUND AND A 20-AMP TWO POLE BREAKER AT THE PANEL. A TEMPORARY 3' TALL STAKE SHALL BE PROVIDED TO DESIGNATE THE Pylon SIGN LOCATION UNTIL THE SIGN IS PERMANENTLY INSTALLED. REMOVE POST AFTER SIGN IS INSTALLED.
- B. SITE / PARKING LOT LIGHTING: PROVIDE ADEQUATE POLE AND/OR WALL LIGHTING FOR NIGHT VISION AROUND ENTRY, PARKING AND DUMPSTER PAD AREAS.
- C. MINIMUM OF 1.5 FOOT-CANDLES REQUIRED FOR ALL PAVED AREAS EXCLUDING 15' PERIMETER FROM EDGE OF PAVEMENT.
- D. REQUIRED LIGHTING: A COMBINATION OF POLE LIGHTS, FLOOD LIGHTS WITH ARM AND WALL PACKS WILL BE USED. REFER TO ELECTRICAL SITE PLAN AND SHEET E2 FOR ADDITIONAL INFORMATION.
- E. PLEASE NOTE THAT LIGHTING DESIGN AND LAYOUT SHOULD BE SITE SPECIFIC & MAY REQUIRE ADDITIONAL LIGHTING TO COMPLY WITH SITE DESIGN CONDITIONS. THEREFORE, MAKE PROVISIONS FOR MORE POLE LIGHTING WHEN A SPECIFIC SITE REQUIRES IT.
- F. UNDERGROUND ELECTRICAL SHALL BE PROVIDED TO THE SITE LIGHT POLES.
- G. WHERE LOCAL JURISDICTIONS DO NOT ALLOW DOLLAR GENERAL'S REQUIRED LIGHTING PLAN, AN ALTERNATE SITE LIGHTING PLAN & PHOTOMETRIC PLAN MUST BE SUBMITTED FOR APPROVAL TO THE DOLLAR GENERAL ARCHITECTURAL AND ENGINEERING DEPARTMENT.
- H. PHOTOMETRIC SITE ANALYSIS AVAILABLE THROUGH DOLLAR GENERAL VENDOR, LEDS LLC.
- I. DOLLAR GENERAL VENDOR PRICING FOR WALL PACKS OR POLE LIGHTING AVAILABLE FROM LEDS LLC.
- J. SEE SHEET E2 FOR MORE INFORMATION.
- K. VERIFY LOCAL DARK SKY REQUIREMENTS AND CONTACT VENDORS FOR APPROVED ALTERNATES IF REQUIRED.

**Craig A. Otto**  
ARCHITECT, INC.

DESIGN • PLANNING • ARCHITECTURE

5044 Augusta Road  
Lexington, South Carolina 29072  
Phone (803) 957-9004  
Fax (803) 957-2050

No.	Revisions	Date

All rights reserved. This drawing and the design shown thereon are copyrighted as prescribed by the laws of the United States and are the sole property of Craig A. Otto, Architect, Inc. Anyone duplicating, reproducing, or causing to be reproduced these drawings or the design thereon without permission of the architect will be subject to legal action.

Project Title DOLLAR GENERAL #23725  
US 421 S  
LILLINGTON, NC

Drawing Title SITE PLAN

Consultant **H2L** 116 SOUTH PLEASANTBURG DRIVE  
GREENVILLE, SC 29607  
(864) 233-8844  
www.H2L.com  
CONSULTING ENGINEERS

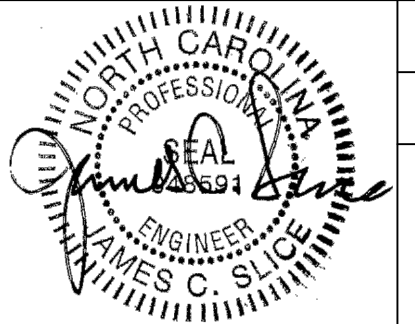
Seal  Date 12/02/2021  
Drawn By JCS  
Drawing No. E3

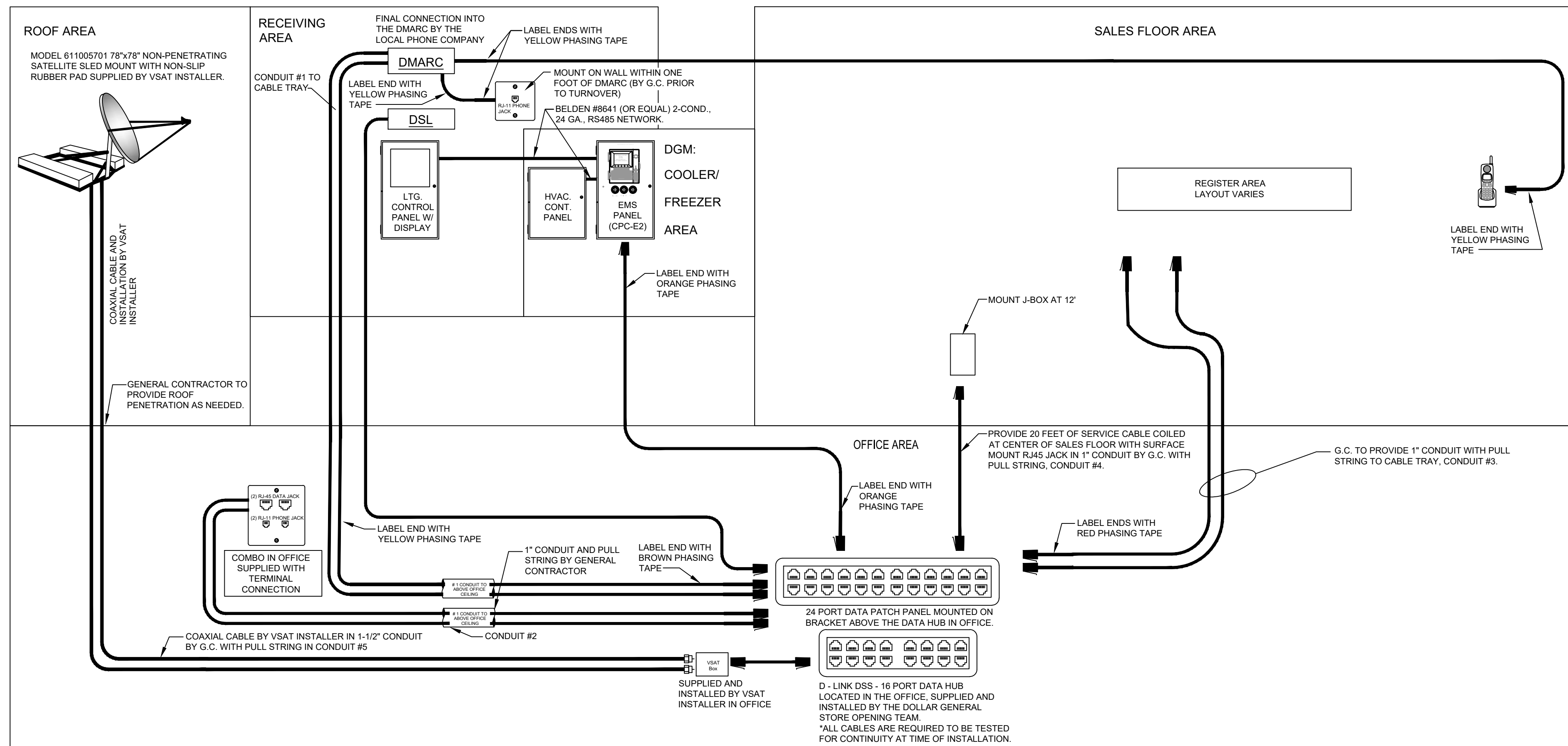

CONDUIT NUMBER	START	END	SIZE	CONDUIT RESPONSIBILITY	*CABLING RESPONSIBILITY
1	RECEIVING AREA	CABLE TRAY	1-1/2"	GENERAL CONTRACTOR	LOW VOLTAGE VENDOR
2	OFFICE VOICE / DATA PORT	OFFICE (HUB)	1"	GENERAL CONTRACTOR	LOW VOLTAGE VENDOR
3	OFFICE (HUB)	CABLE TRAY	1"	GENERAL CONTRACTOR	LOW VOLTAGE VENDOR
4	CENTER OF SALES FLOOR CONNECTION	OFFICE (HUB)	1"	GENERAL CONTRACTOR	LOW VOLTAGE VENDOR
5	SATELLITE	OFFICE (HUB)	1-1/2"	GENERAL CONTRACTOR	LOW VOLTAGE VENDOR

\*UNLESS OTHERWISE NOTED, ALL RESPONSIBILITIES SHOULD FOLLOW THIS CHART.

ALL CABLES AT THE OFFICE WILL NEED TO BE WRAPPED IN PHASING TAPE CONSISTENT WITH THE FOLLOWING COLORS:

RED TAPE — CASH REGISTER DATA  
 BLUE TAPE — ELEC. EMS DATA  
 BROWN TAPE — OFFICE DATA  
 ORANGE TAPE — COOLER/FREEZER EMS DATA  
 YELLOW TAPE — PHONE CABLE TO DMARC

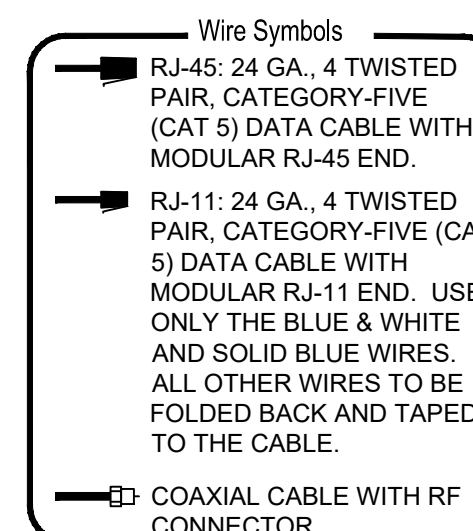

**NOTES:**

A. WHEN LOW VOLTAGE PERMITS ARE REQUIRED, THE GC/DEVELOPER/LLD IS RESPONSIBLE FOR OBTAINING ALL LOW VOLTAGE PERMITS.

B. LOW VOLTAGE VENDOR RESPONSIBLE FOR ALL WIRE MANAGEMENT IN CABLE TRAY.

C. GC TO PROVIDE AND INSTALL CABLE TRAY AND ALL CONDUIT.

1 DATA CABLING DIAGRAM  
E4 NTS

**Craig A. Otto**  
ARCHITECT, INC.  
DESIGN • PLANNING • ARCHITECTURE

5044 Augusta Road  
Lexington, South Carolina 29072  
Phone (803) 957-9004  
Fax (803) 957-2050

No.	Revisions	Date

All rights reserved. This drawing and the design shown thereon are copyrighted as prescribed by the laws of the United States and are the sole property of Craig A. Otto, Architect, Inc. Anyone duplicating, reproducing, or causing to be reproduced these drawings or the design thereon without permission of the architect will be subject to legal action.

Project Title: DOLLAR GENERAL #23725  
US 421 S  
LILLINGTON, NC

Drawing Title: DATA CABLING DIAGRAM

Consultant: **H2L** CONSULTING ENGINEERS  
116 SOUTH PLEASANTBURG DRIVE  
GREENVILLE, SC 29607  
(864) 233-8844  
www.H2L.com

Seal: Date: 12/02/2021  
Drawn By: JCS  
Drawing No.: E4

H2L Project #2111 12.02.2021

PANEL "A", 120/208 VOLT, 3 PHASE, 4 WIRE, 400A FRAME, 400A MCB, SURFACE MOUNT, NEMA 1												
CKT #	LOAD	DESCRIPTION	AMP	POLE	TOTAL PER PHASE IN WATTS			DESCRIPTION	LOAD	CKT #		
					A	B	C					
1	20871				20971			20	1	AUTOMATIC DOOR*	100	2
3	20871	PAC UNIT # 1	200	3	21231			20	1	TELEPHONE BOARD/BUZZER*	360	4
5	20871				21051			20	1	ENERGY MANAGEMENT*	180	6
7	20871				21051			20	1	OUTDOOR HVAC RECEPT.	180	8
9	20871	PAC UNIT # 2	200	3	21051			20	1	OUTDOOR DRINK VENDING	180	10
11	20871				21051			20	1	OUTDOOR CONV RECEPT.	180	12
13		SPARE	20	1	100			20	1	EXHAUST FAN	100	14
15		SPARE	20	1	100			20	1	EXHAUST FAN	100	16
17		SPARE	20	1	500			20	1	INTERFACE EQUIP	500	18
19		SPARE	20	1	500			20	1	VSAT DATA HUB EQUIP	500	20
21		SPARE	20	1	960			20	1	CCTV EQUIP	960	22
23		SPARE	20	1	924			20	1	CLICK & COLLECT FREEZER/COOLER*	924	24
25	1650	WATER HEATER*	20	1	1650			20	1	SPARE	0	26
27		SPARE	20	1	0			20	1	SPARE	0	28
29	500	DRINKING FOUNTAINS*	20	1	500			20	1	SPARE	0	30
31	1200	OUTDOOR ICE MERCHANDISER*	20	1	1200			20	1	SPARE	0	32
33	1200	HIGH KIOSK	20	1	1200			20	1	SPARE	0	34
35	960	SODA COOLERS*	20	1	960			20	1	SPARE	0	36
37	1600	DRINK COOLERS*	20	1	1600			20	1	SPARE	0	38
39	1600	SODA COOLERS*	20	1	1600			20	1	SPARE	0	40
41		SPARE	20	1	0			20	1	SPARE	0	42
NEW					TOTAL	47072	46142	44996	TOTAL CONNECTED = 138200.0 WATTS			
*HANDLE LOCK-ON DEVICE					LOCATED AT:	383.9 AMPS						

PANEL "B", 120/208 VOLT, 3 PHASE, 4 WIRE, 225 AMP, MLO, SURFACE MOUNT, NEMA 1												
CKT #	LOAD	DESCRIPTION	AMP	POLE	TOTAL PER PHASE IN WATTS			DESCRIPTION	LOAD	CKT #		
					A	B	C					
1	180	NIGHT LIGHTS*	20	1	180			20	1	SPARE		2
3	135	RECEIVING LIGHTS*	20	1	635			20	1	SECURITY RECEPT.*	500	4
5	630	70% SALES LIGHTS - ROWS 2 & 3	20	1	1170			20	1	OFFICE RECEPT.*	540	6
7	270	70% SALES LIGHTS - ROWS 5 & 6	20	1	810			20	1	BREAK RM RECEPT.	540	8
9	540	30% SALES LIGHTS - ROWS 1 & 4	20	1	540			20	1	SPARE		10
11	450	70% SALES LIGHTS - ROWS 8 & 9	20	1	450			20	1	SPARE		12
13	150	BREAK RM/OFF JR. R. LIGHTS*	20	1	1230			20	1	BULKHEAD RECEPT.	1080	14
15	450	30% SALES LIGHTS - ROWS 7 & 10	20	1	500			20	1	EMERGENCY/EEXIT LIGHTS*	50	16
17	585	70% SALES LIGHTS - ROWS 12 & 15	20	1	585			20	1	SPARE		18
19		SPARE	20	1	0			25	1	SPARE		20
21		SPARE	20	1	0			25	1	SPARE		22
23	900	BUILDING SIGN	20	1	900			25	1	SPARE		24
25	900	PYLON SIGN	20	1	900			20	1	SPARE		26
27	300	SITE LIGHTING	20	1	300			20	1	SPARE		28
29	1400	SITE LIGHTING	20	1	2600			20	1	POWER TERMINAL BROWN*	1200	30
31		SPARE	20	1	1200			20	1	POWER TERMINAL BROWN*	1200	32
33	140	LEFT SIDE EXT. WALL LTS	20	1	1340			20	1	POWER TERMINAL GREEN*	1200	34
35	584	FRONT EXT. WALL/CANOPY LTS	20	1	1784			20	1	POWER TERMINAL GREEN*	1200	36
37	930	SPARE	20	1	2130			20	1	POWER TERMINAL GREEN*	1200	38
39	930	SPARE	20	1	2130			20	1	POWER TERMINAL GREEN*	1200	40
41	50	EXTERIOR DUSK/DAWN	20	1	1250			20	1	POWER TERMINAL BROWN*	1200	42
43		SPARE	20	1	1200			20	1	POWER TERMINAL BROWN*	1200	44
45		SPARE	20	1	0			20	1	SPARE		46
47		SPARE	20	1	0			20	1	SPARE		48
49		SPARE	20	1	0			20	1	SPARE		50
51		SPARE	20	1	180			20	1	DISPLAY LIGHT	180	52
53		SPARE	20	1	864			20	1	GATORADE*	864	54
NEW ( ), EXISTING ( )					TOTAL	7650	5625	9603	TOTAL CONNECTED = 22878 WATTS			
*HANDLE LOCK-ON DEVICE					LOCATED AT:	63.6 AMPS						

CONNECTIVE LOAD SUMMATION	
INTERIOR LIGHTING	= 3440.0 WATTS
SITE AND SIGN LIGHTING	= 6134.0 WATTS
RECEPTACLE LOAD	= 16884.0 WATTS
HVAC LOAD	= 125226.0 WATTS
EQUIPMENT LOAD	= 56882.0 WATTS
<b>TOTAL LOAD</b>	<b>= 208566.0 WATTS</b>
	<b>579.4 AMPS</b>

DEMAND LOAD SUMMATION	
INTERIOR LIGHTING	= 4300.0 WATTS
SITE AND SIGN LIGHTING	= 7667.5 WATTS
RECEPTACLE LOAD	= 13442.0 WATTS
HVAC LOAD	= 100180.8 WATTS
EQUIPMENT LOAD	= 56882.0 WATTS
<b>TOTAL LOAD</b>	<b>= 182472.3 WATTS</b>
	<b>506.9 AMPS</b>

VERIFY ALL WIRE SIZES SHOWN TO MEET LOCAL CODES. ADJUST, AS REQUIRED, PER LOCAL CODES.

BRANCH CIRCUIT WIRING TABLE					
CIRCUIT(S)	WIRE	CONDUIT	VOLTS	PHASE	GROUND
All circuits unless identified below.					
	(2)#12	3/4"	120	1	#12
Panel R - 1/3, 5/7, 9/11, 13/15, 21/23, 25/27.	(3)#12	3/4"	208	1	#12
Panel R - 14/16	(3)#10	3/4"	208	1	#10
Panel R - 2/4, 6/8, 10/12	(3)#8	3/4"	208	1	#10
Panel A - 1/3/5, 7/9/11	(3)#20	1-1/2"	208	3	#6

PANEL "R", 120/208 VOLT, 3 PHASE, 4 WIRE, 225 AMP, MLO, SURFACE MOUNT, NEMA 1												
CKT #	LOAD	DESCRIPTION	AMP	POLE	TOTAL PER PHASE IN WATTS			DESCRIPTION	LOAD	CKT #		
					A	B	C					
1	1300				5200			40	2	A-2-A REACH-IN FROZEN CASE*	3900	2
3	1300	A-1-A REACH-IN DAIRY CASE*	15	2	5200			40	2	A-2-B REACH-IN FROZEN CASE*	3900	4
5	1300				4500			40	2	A-2-C REACH-IN FROZEN CASE*	3200	6
7	1300	A-1-B REACH-IN DAIRY CASE*	15	2	4500			40	2	A-2-D REACH-IN FROZEN CASE*	3200	8
9	1300				4500			40	2	A-2-E REACH-IN FROZEN CASE*	3200	10
11	1300	A-1-C REACH-IN DAIRY CASE*	15	2	4500			40	2	A-2-F REACH-IN FROZEN CASE*	3200	12
13	1300				3900			25	2	A-3 REACH-IN FROZEN CASE*	2600	14
15	1300	A-1-D REACH-IN DAIRY CASE*	15	2	3900			25	2	A-3 REACH-IN FROZEN CASE*	2600	16
17	1150	72" COOLER	20	1	2070			20	2	72" FREEZER	920	18
19	1150	PRODUCE COOLER*	20	1	2070			20	2	PRODUCE COOLER*	920	20
21	1300				2964			20	2	PRODUCE COOLER*	1664	22
23	1300	COOLER	15	2	2964			20	2	PRODUCE COOLER*	1664	24
25	250				250			20	1	SPARE		26
27	250	AIR CURTAIN	20	2	250			20	1	SPARE		28
29		SPARE	20	1	0			20	1	SPARE		30
31		SPARE	20	1	0			20	1	SPARE		32
33		SPARE	20	1	360			20	1	SERVICE RECEPTS ON ROOF	360	34
35		SPARE	20	1	360			20	1	SPARE	360	36
37		SPARE	20	1	0			20	1	SPARE		38
39		SPARE	20	1	0			20	1	SPARE		40
41		SPARE	20	1	0			20	1	SPARE		42
NEW (X), EXISTING ( )					TOTAL	15920	17174	14394	TOTAL CONNECTED = 47488 WATTS			
*HANDLE LOCK-ON DEVICE					LOCATED AT:	131.9 AMPS						

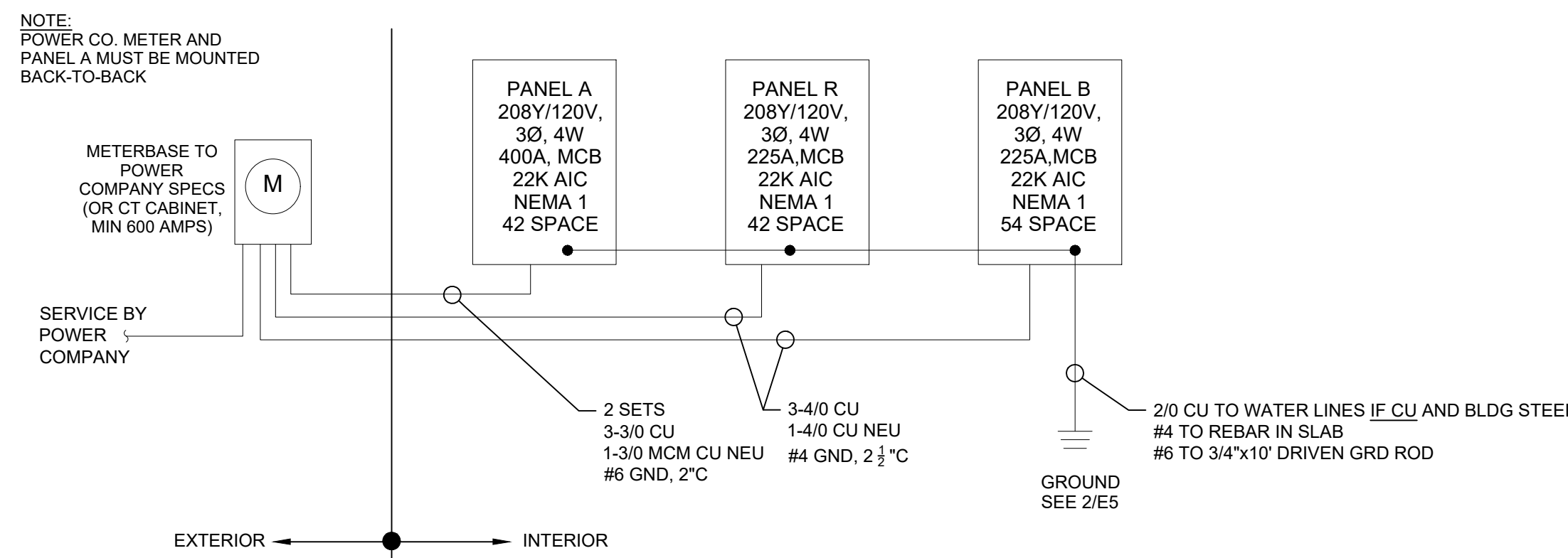

1 ELECTRICAL PANEL SCHEMATIC  
E5 NTS

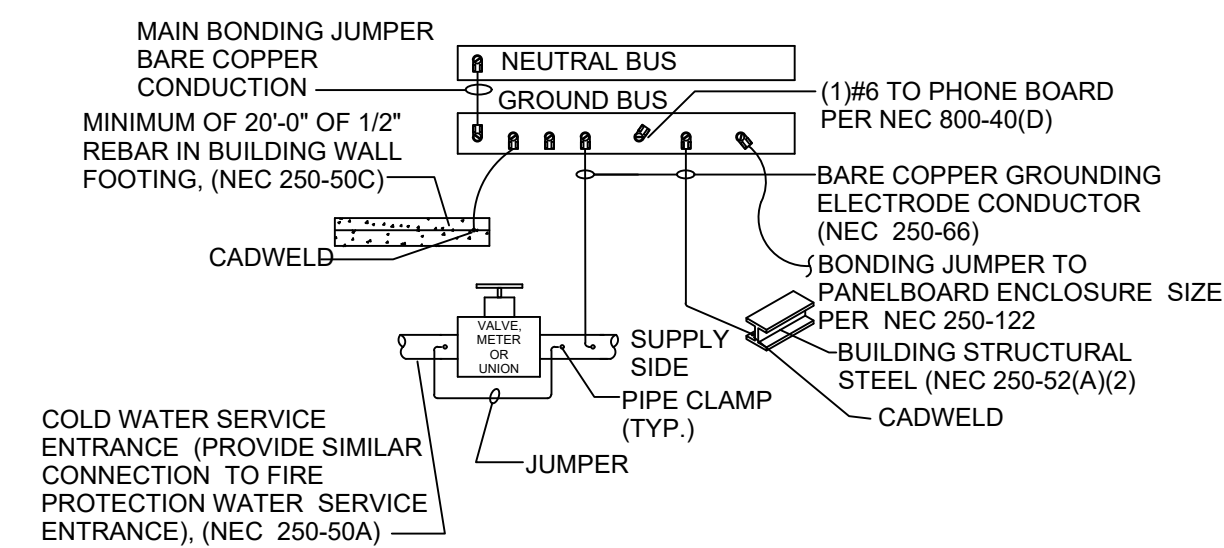

NOTE: ALL GROUNDING SHALL BE INSTALLED IN ACCORDANCE WITH ARTICLE 250-50 OF THE NATIONAL ELECTRICAL CODE.

2 GROUNDING DETAIL  
E5 NTS

**Craig A. Otto**  
ARCHITECT, INC.

DESIGN • PLANNING • ARCHITECTURE

5044 Augusta Road  
Lexington, South Carolina 29072  
Phone (803) 957-9004  
Fax (803) 957-2050

No.	Revisions	Date
1	INSPECTOR COMMENTS	01/02/2022

All rights reserved. This drawing and the design shown thereon are copyrighted as prescribed by the laws of the United States and are the sole property of Craig A. Otto, Architect, Inc. Anyone duplicating, reproducing, or causing to be reproduced these drawings or the design thereon without permission of the architect will be subject to legal action.

Project Title DOLLAR GENERAL #23725  
US 421 S  
LILLINGTON, NC

Drawing Title PANEL SCHEDULES

Consultant **H2L** CONSULTING ENGINEERS 116 SOUTH PLEASANTBURG DRIVE GREENVILLE, SC 29607 (864) 233-8844 www.H2L.com

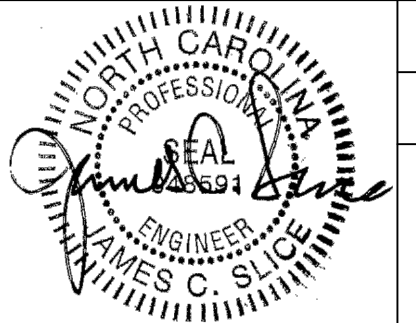
Seal  Date 12/02/2021  
Drawn By JCS  
Drawing No. E5

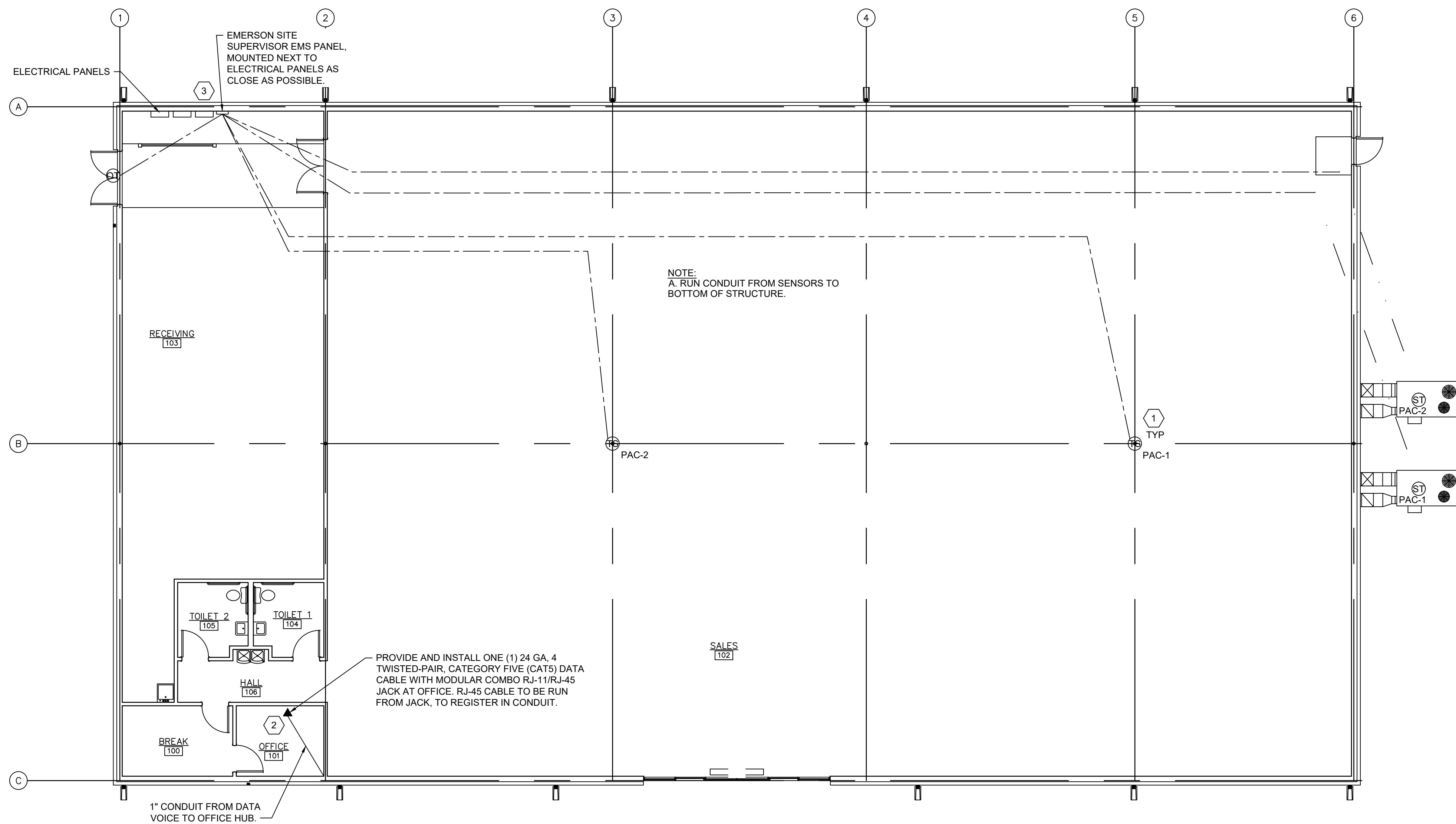

1 EMS LOW VOLTAGE PLAN  
E6 SCALE: 1/8" = 1'-0"

NOTE:  
PLAN IS DIAGRAMMATIC ONLY. HOLD CONDUIT TIGHT TO EXPOSED MAIN GIRTS AND RUN AS HIGH AS POSSIBLE ALONG PERIMETER WALLS TO RECEIVING AREA.

**EMERSON CONTACT**

A. PLEASE CONTACT EMERSON FOR FULL DETAILS.  
B. CONTACT TONY VERTUCA - NATIONAL ACCOUNT EXECUTIVE (404)824-9389.  
Tony.Vertuca@Emerson.com

**CONTROL PANEL NOTES**

1. EMS SYSTEM SHOULD BE TESTED FOR HVAC OPERATION, INTERIOR LIGHTING, EXTERIOR LIGHTING AND SIGN LIGHTING PRIOR TO CONTRACTOR'S ELECTRICAL POSSESSION DATE. USE OUTSIDE LIGHT AND SIGN LIGHT OVERRIDE FOR EXTERIOR TESTING.

**SENSOR PLAN KEYED NOTES**

1. ALWAYS INSTALL THESE SENSORS AT 8'-0" AFF IF ADDITIONAL HVAC UNITS ARE USED, ADD ADDITIONAL TEMPERATURE SENSORS "TS".

2. PHONE LINE #1 - TWO RJ-11 PORTS. ONE (1) LOCATED IN OFFICE W/RJ-45 DATA JACK COMBO AND ONE (1) AT REGISTER. 24 GA. CAT 5, 4-PAIR TWISTED WIRE ONLY. USE BLUE AND BLUE & WHITE WIRES. HOOK TO LINE #1 TERMINAL IN RJ-11 JACK EACH PHONE JACK TO HAVE DEDICATED. SEPARATE HOME RUN TO DMARC. LABEL AS "PHONE" AT THE DESTINATION AND AT DMARC. PHONE COMPANY PROVIDES FINAL HOOK UP TO DMARC ONLY. PHONE LINE #2 - RJ-11 PHONE JACK SUPPLIED AND WIRED BY CONTRACTOR.

3. EMS REFRIGERATION PANEL CX E2 400. PANEL BY OTHERS. CONNECTION FROM THIS PANEL TO HVAC AND LIGHTING PANEL BY OTHERS. ELECTRICAL CONTRACTOR TO RUN AN EMPTY 1-1/2" C. WITH PULL ROPE BETWEEN THE TWO PANELS.

DEVICE SCHEDULE					
SYMB	DESCRIPTION	CABLE TYPE	SUPPLIER	INSTALLER	NOTES
OT	OUTDOOR AIR TEMP MOUNTED 8'-0" A.F.F.	BELDEN 8761 OR EQUIVALENT (22AWG, 2C, STRANDED, SHIELDED)	EMS SUPPLIER	GENERAL CONTRACTOR	(1) PER RECEIVING ENTRY
ST	SUPPLY TEMP (501-1121) IN SUPPLY DUCT	BELDEN 8761 OR EQUIVALENT (22AWG, 2C, STRANDED, SHIELDED)	EMS SUPPLIER	GENERAL CONTRACTOR	(1) PER HVAC UNIT
TS	TEMP SPACE SENSOR (809-6590) 8'-0" A.F.F.	BELDEN 8761 OR EQUIVALENT (22AWG, 2C, STRANDED, SHIELDED)	EMS SUPPLIER	GENERAL CONTRACTOR	(1) PER HVAC UNIT ZONE
●	RJ-11/RJ-45 DATA JACK PHONE COMBO	CAT-5 DATA CABLE (24AWG, 4 TWISTED PAIR)	GENERAL CONTRACTOR	GENERAL CONTRACTOR	(1) AT OFFICE COMPUTER CART
Ⓜ	MOTION SENSOR SWITCH	LEVITON EZ-FIND ODS-10-IDW	GENERAL CONTRACTOR	GENERAL CONTRACTOR	(1) PER RESTROOM (1) PER BREAK ROOM (1) PER OFFICE

**EMS GENERAL NOTES**

1. EMS SUPPLIER NOTE: CUSTOMIZED DOLLAR GENERAL EMS PANEL REQUIRES STORE #, CITY, STATE, ZIP CODE & QTY. OF HVAC UNITS OF THE INSTALL SITE WHEN ORDERING. EMS SYSTEMS INSTALLATION GUIDE WITH PHOTOS IS AVAILABLE ON NATIONAL ACCOUNT WEBSITE. ALL QUESTIONS PERTAINING TO THE EMS PANEL, SYSTEM INSTALLATION & SETUP SHOULD BE DIRECTED TO EMERSON'S DOLLAR GENERAL SUPPORT TEAM AT 770-425-2724.

2. ALL SIGN & LIGHTING CIRCUITS MUST BE FED THROUGH THE DESIGNATED CONTACTORS AS NOTED ON THIS PAGE.

3. ALL LOW VOLTAGE HVAC & DOOR SENSORS MUST BE CONNECTED TO THE PROPER TERMINAL. 24 GA. SHIELDED (SHIELD MUST BE GROUNDED) CABLE, BELDEN #8641, 2 CONDUCTOR WIRE OR ITS EQUIVALENT IS REQUIRED.

4. COOLER & FREEZER HOME RUNS WILL BE TERMINATED AT ALL POINTS BY DOLLAR GENERAL REFRIGERATION DEPARTMENT.

**TESTING NOTES**

TESTING OF HVAC UNITS THRU EMS PANEL IS ACCOMPLISHED BY SIMPLY WARMING UP OR COOLING DOWN A SPACE TEMPERATURE SENSOR (USING A BLOW DRYER OR ELECTRONIC EQUIPMENT DUSTER AEROSOL) AND WATCH THE FAN, HEAT AND COOL STAGES CYCLE ON AND OFF. THIS REQUIRES TWO PEOPLE AT ALL TIMES...ONE TO WATCH THE SCREEN AND THE OTHER TO WATCH OPERATION OF THE AHU. WHEN COMPLETE, PRESS THE HOME BUTTON TO RETURN TO THE MAIN SCREEN.

**GENERAL NOTES**

A. REFER TO E1 FOR GENERAL CONTRACTOR RESPONSIBILITIES. E.C. MAY USE CABLE TRAY FOR LOW VOLTAGE CABLES, SEE 2/E2.

B. RUN CONDUIT FROM SENSORS TO BOTTOM OF STRUCTURE.

C. REFRIGERATION UNITS TO BE CONNECTED TO EMS PANEL BY DOLLAR GENERAL REFRIGERATION CONTRACTOR.

**Craig A. Otto**  
ARCHITECT, INC.  
DESIGN • PLANNING • ARCHITECTURE

5044 Augusta Road  
Lexington, South Carolina 29072  
Phone (803) 957-9004  
Fax (803) 957-2050

No.	Revisions	Date

All rights reserved. This drawing and the design shown thereon are copyrighted as prescribed by the laws of the United States and are the sole property of Craig A. Otto, Architect, Inc. Anyone duplicating, reproducing, or causing to be reproduced these drawings or the design thereon without permission of the architect will be subject to legal action.

Project Title: DOLLAR GENERAL #23725  
US 421 S  
LILLINGTON, NC

Drawing Title: EMS LOW VOLTAGE PLAN

Consultant: **H2L** CONSULTING ENGINEERS  
116 SOUTH PLEASANTBURG DRIVE  
GREENVILLE, SC 29607  
(864) 233-8844  
www.H2L.com

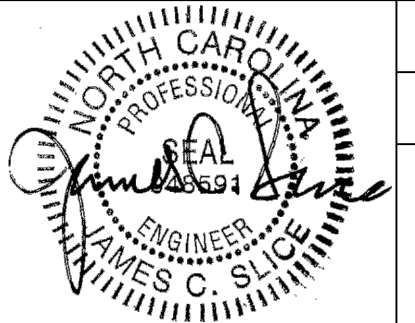
Seal: 

Date: 12/02/2021  
Drawn By: JCS  
Drawing No.: E6

H2L Project #21111 12.02.2021