

SECTION VIEW - MODEL 4224ND-2
HOOD - #1

DUCT NOZZLE AND
PLENUM SPRAY BAR LOCATION

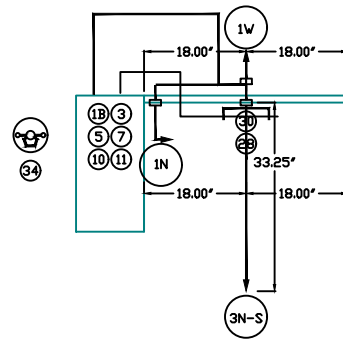
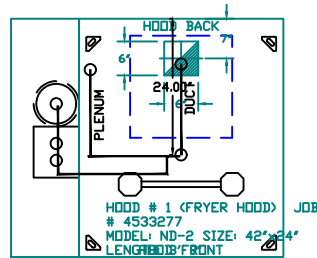

FRYER-H V/DRIP BOARD
HIGH PROXIMITY
18.00" L X 18.00" D

FRYER HOOD FIRE SYSTEM

NOTES

- FIELD PIPE DROPS AS SHOWN
- SLEEVING, ELBOWS, TEES, AND NOZZLES SUPPLIED BY CAS.
- RELOCATE NOZZLES IF FLOW PATTERN IS BLOCKED BY SHELVING, SALAMANDERS, ETC.
- MAXIMUM 9 ELBOWS IN SUPPLY LINE.
- MINIMUM 72 INCHES OF AGENT LINE FROM TANK TO FIRST NOZZLE COVERING A RANGE, FRYER, OR WOK TO REFLECT GENERAL PIPING REQUIREMENTS.
- IF APPLICABLE, PRE-PIPED CHARBROILER DROPS ARE SHIPPED LOOSE.
- FACTORY PIPING EXTENDS A MAXIMUM OF 6" ABOVE THE TOP OF THE HOOD.
- APPLIANCE DIMENSIONS LISTED REPRESENT THE COOKING SURFACE SIZE, NOT THE OVERALL APPLIANCE SIZE.
- THIS FIRE SYSTEM COMPLIES WITH U.L. 300 REQUIREMENTS.

Job Name: HARDEE'S 2471 NC 87 S., CAMERON, NC 28326

Fire System Co.: BFE International, 115 Best Wood Dr., Clayton, NC 27520
Drawn By: CAS & MWE

JOB #: 4533277.

SYSTEM SIZE: ANSUL-3.0 TOTAL FP REQUIRED: 5.
HOOD # 1 3' 0.00" LONG x 42' WIDE x 24' HIGH.
RISER # 1 SIZE: 6" x 6".
HOOD # 1 METAL BLOW-OFF CAPS INCLUDED.

LEGEND - FIRE CABINET ANSUL SYSTEM

- 1A 1.5 GALLON TANK.
- 1B 3 GALLON TANK.
- 2 DEM AUTOMAN RELEASE.
- 3 DEM REGULATED RELEASE.
- 4 DEM REGULATED ACTUATOR.
- 5 ANSULEX LIQUID AGENT (3 GAL.).
- 6 ANSULEX LIQUID AGENT (1.5 GAL.).
- 7 CARTRIDGE (101-20).
- 8 CARTRIDGE (101-10).
- 9 CARTRIDGE (101-30).
- 9A CARTRIDGE (LT-A-101-30).
- 9B DOUBLE TANK CARTRIDGE.
- 10 TEST LINK.
- 11 DOUBLE MICROSWITCH.
- 12 HOSE ASSEMBLY.
- 1100 DUCT NOZZLE (430913).
- 2W DUCT NOZZLE (419337).
- 1W NOZZLE ASSEMBLY (419336).
- 1F NOZZLE ASSEMBLY (419333).
- 1N NOZZLE ASSEMBLY (419335).
- 1/2N NOZZLE ASSEMBLY (419334).
- 3N NOZZLE ASSEMBLY (419338).
- 245 NOZZLE ASSEMBLY (419340).
- 230 NOZZLE ASSEMBLY (419339).
- 2120 NOZZLE ASSEMBLY (419343).
- 290 NOZZLE ASSEMBLY (419342).
- 260 NOZZLE ASSEMBLY (419341).
- 28 DETECTOR BRACKET.
- 29 LOW TEMP FUSIBLE LINK.
- 30 HIGH TEMP FUSIBLE LINK.
- MGV MECHANICAL GAS VALVE.
- EGV ELECTRICAL GAS VALVE.
- 34 REMOTE MANUAL PULL STATION.
- S SWIVEL ADAPTOR.

Reviewed For Code Compliance By:
D. Banks Wallace
Chief Deputy Fire Marshal
10/14/2020 1:03:47 PM