

March 28, 2003

(Formerly System No. 147)

F Ratings -- 1, 2, 3 and 4 Hr (See Items 2 and 3)

T Ratings -- 0, 1, 2, 3, and 4 Hr (See Item 3)

L Rating At Ambient - less than 1 CFM/sq ft

L Rating At 400 F - less than 1 CFM/sq ft

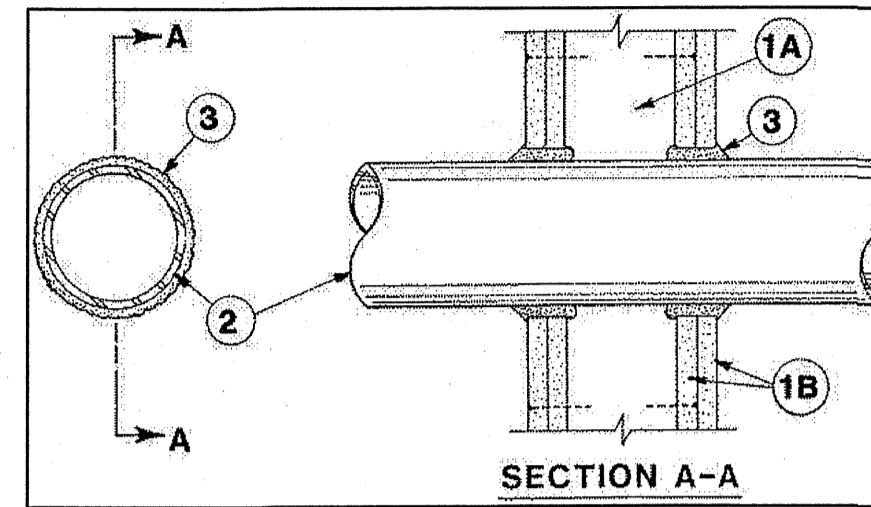

1. Wall Assembly -- The 1,2,3 or 4 hr fire-rated gypsum wallboard/stud wall assembly shall be constructed of the materials and in the manner described in the individual U300 or U400 Series Wall or Partition Designs in the UL Fire Resistance Directory and shall include the following construction features:

- A. Studs -- Wall framing may consist of either wood studs (max 2 hr fire-rated assemblies) or steel channel studs. Wood studs to consist of nom 2 by 4 in. lumber spaced 16 in. OC with nom 2 by 4 in. lumber end plates and cross braces. Steel studs to be min 3-5/8 in. wide by 1-3/8 in. deep channels spaced max 24 in. OC.
- B. Gypsum Board\* -- Nom 1/2 or 5/8 in. thick, 4 ft. wide with square or tapered edges. The gypsum wallboard type, thickness, number of layers, fastener type and sheet orientation shall be as specified in the individual U300 or U400 Series Design in the UL Fire Resistance Directory. Max diam of opening is 26 in.

2. Through-Penetrant-- One metallic pipe, conduit or tubing installed either concentrically or eccentrically with the firestop system. The annular space between pipe, conduit, or tubing and periphery of opening shall be min of 0 in. (point contact) to max 2 in. Pipe, conduit or tubing to be rigidly supported on both sides of wall assembly. The following types and sizes of metallic pipes, conduits or tubing may be used:

- A. Steel Pipe -- Nom 24 in. diam (or smaller) Schedule 10 (or heavier) steel pipe.
- B. Iron Pipe -- Nom 24 in. diam (or smaller) service weight (or heavier) cast iron soil pipe, nom 12 in. diam (or smaller) or Class 50 (or heavier) ductile iron pressure pipe.
- C. Conduit -- Nom 6 in. diam (or smaller) steel conduit or nom 4 in diam (or smaller) steel electrical metallic tubing.
- D. Copper Tubing -- Nom 6 in. diam (or smaller) Type L (or heavier) copper tubing.
- E. Copper Pipe -- Nom 6 in. diam (or smaller) Regular (or heavier) copper tubing.
- F. through Penetrating Product\* -- Flexible Metal Piping The following types of steel flexible metal gas piping may be used:

- 1. Nom 2 in diam (or smaller) steel flexible metal gas piping. Plastic covering on piping may or may not be removed on both sides of floor or wall assembly.
- 2. Nom 1 in diam (or smaller) steel flexible metal gas piping. Plastic covering on piping may or may not be removed on both sides of floor or wall assembly.

OMEGA FLEX INC

TITLEFLEX CORP

A BUNDDY CO

3. Nom 1 in diam (or smaller) steel flexible metal gas piping. Plastic covering on piping may or may not be removed on both sides of floor or wall assembly.

WARD MFG INC

3. Fill Void or Cavity Material\* -- Caulk -- Min 5/8, 1-1/4, 1-7/8 and 2-1/2 in. thickness for caulk for 1,2,3 and 4 hr rated assemblies, respectively, applied within annulus, flush with both surfaces of wall. Min 1/4 in. dia bead of caulk applied to gypsum board/penetrant interface at point contact location on both sides of wall. The hourly T rating of the firestop system is dependent upon the hourly fire rating of the wall assembly in which it is installed, as shown in the following table. The hourly T rating of the firestop system is dependent upon the type or size of the pipe or conduit and the hourly fire rating of the wall assembly in which it is installed, as tabulated below:

Max Pipe or Conduit Diam In	F RATING Hr	T RATING Hr
1	1 or 2	0+, 1 or 2
1	3 or 4	3 or 4
4	1 or 2	0
6	3 or 4	0
12	1 or 2	0

\*When copper pipe is used, T Rating is 0 h.

3M COMPANY-- CP 25WB+.

\*Bearing the UL Classification Mark

4 PENETRATION DETAIL SCALE: NOT TO SCALE

SYMBOL LEGEND -- PLUMBING

SYMBOL	DESCRIPTION (U.O.N.)
	WASTE PIPING (W)
	VENT PIPING (V)
	COLD WATER PIPING (CW)
	HOT WATER PIPING (HW)
	COMPRESSED AIR PIPING
	CLEANOUT FINISH FLOOR
	WALL/HORIZONTAL CLEANOUT
	CLEANOUT FINISH GRADE--PROVIDE FLUSH CONCRETE COLLAR AND BRONZE COVER
	DIELECTRIC UNION
	SHUT-OFF VALVE
	VENT THRU ROOF (VTR)
	FREEZE PROOF, HOSE BIBB (FPHB/HB)
	ABOVE FINISHED FLOOR
	UNLESS OTHERWISE NOTED
	2 HOUR FIRE BARRIER

FIXTURE SCHEDULE -- PLUMBING \*

- EMH\* ELECTRIC WATER HEATER  
A.O. SMITH MODEL ECS-40, 40 GALLON, 4,500 WATT, 48 GPH RECOVERY AT 40 DEGREE TEMPERATURE RISE. 3/4" INLET AND OUTLET, 240V, 1 PH. PROVIDE DRAIN PAN, EXPANSION TANK AND PRESSURE RELIEF VALVE.
- ET\* EXPANSION TANK  
AMTROL MODEL ST-5, 2.0 GALLON, STEEL CONSTRUCTION, NON-ASME RATED.
- WC\* WATER CLOSET (ADA FLUSH TANK)  
KOHLER HIGHLINE WATER CLOSET, K-3979, ADA COMPLIANT 1.6 GPF. PROVIDE WITH K-4731 ADA SEAT, K-7637 SUPPLY AND STOP, WAX SEAL, CROSET BOLT KIT. PROVIDE MODEL WITH FLUSH CONTROL ON SIDE OPPOSITE GRAB BAR.
- LAV\* LAVATORY (WALL MOUNT)  
KOHLER CHESAPEAKE LAVATORY, K-1728, VITREOUS CHINA, 4" CENTERS, ADA COMPLIANT. PROVIDE DELTA MODEL 523LF-HGMDF FAUCET, 0.5 GPM MAX WITH GRID STRAINER. PROVIDE P-TRAP AND SHUT-OFF VALVES.
- VB\* ICE MAKER VALVE BOX  
OATEY VALVE BOX WITH 3/8" BRONZE SHUT-OFF VALVE. FLUSH TO WALL.
- SINK\* BREAK ROOM SINK  
ELKAY LR2222 SINGLE BASIN STAINLESS STEEL SINK (MODEL LRAD2222 IF ADA COMPLIANCE REQUIRED), 18 GA., SELF-RIMMING, FURNISHED WITH THREE FAUCET HOLES AND CENTER DRAIN. PROVIDE ELKAY COMMERCIAL FAUCET MODEL LK810A08L2 WITH TWO LEVER HANDLES, CHROME PLATED BRASS P-TRAP AND SHUT-OFF VALVES. COORDINATE EXACT UNIT WITH OWNER AND GENERAL CONTRACTOR. COORDINATE SIZE WITH CABINETRY PRIOR TO ORDERING.
- FD\* FLOOR DRAIN  
ZURN MODEL Z415 WITH HEEL-PROOF TYPE B STRAINER, CAST IRON W/NICKEL BRONZE TOP, 5" DRAIN WITH 3" CONNECTION. PROVIDE TRAP PRIMER CONNECTION IF REQUIRED.
- FPHB\* FREEZE PROOF HOSE BIBB  
WOODFORD MODEL #19, FREEZE PROOF HOSE BIBB WITH BACKFLOW PREVENTER. COORDINATE MOUNTING W/TENANT. PROVIDE TEE KEY OR STEM LOCK SL-17 IF REQUIRED.
- RPZ\* 1" REDUCED PRESSURE BACKFLOW PREVENTER  
WATTS MODEL #09M1Q1-1" BACKFLOW PREVENTER BRONZE CONSTRUCTION. PROVIDE IN HOT BOX W/HEAT TRACING.

\* OR APPROVED EQUAL. SUBMIT ALL ITEMS FOR APPROVAL BY TENANT AND ARCHITECT PRIOR TO ORDERING.  
ALL OTHER PLUMBING FIXTURES SHOWN ARE PROVIDED BY THE TENANT AND INSTALLED BY THE PLUMBING CONTRACTOR. SEE PLANS FOR NUMBER AND LOCATION. COORDINATE ALL REQUIREMENTS WITH EQUIPMENT SUPPLIER.

DIVISION 15A -- PLUMBING

- 1.1 DESCRIPTION OF THE WORK
- A. Work under this section includes, but is not necessary limited to, furnishing and installing the following:
  - Plumbing fixtures, water heaters, and any other equipment necessary.
  - Cold and hot water piping and insulation.
  - DWV piping.
  - Compressed air, vacuum piping.
  - Connection of all equipment; drain, vent, water, air, vacuum.
- B. All work under this contract shall be installed in compliance with the latest edition of the following codes and standards insofar as they apply:
  - The National Electrical Code.
  - 2018 N.C. Building Code: Plumbing, and all applicable category codes.
  - American Society of Sanitary Engineering Standard 1010.
  - All local codes and ordinances.
- C. These codes are minimum standards. If codes require a more stringent method of construction than the specifications require, the codes shall govern.
- D. The Plumbing Contractor shall be licensed in the State of North Carolina and have all local licenses required for the work.
- E. Obtain all permits, licenses, inspections, etc., required for the work, and pay for the same.
- 1.2 INTENT
- A. The intent of these specifications and accompanying drawings is to convey as reasonably as possible the requirements for a complete job ready for the building to operate. The Plumbing Contractor shall take this into consideration and include in his base bid allowance for contingencies as will allow him to provide minor pieces of equipment and labor not specifically indicated but required for the job to operate properly, at no additional cost to the Owner.
- 1.3 COORDINATION
- A. Coordinate work with other contractors. Notify Architect of apparent conflicts early to expedite construction. If structural damage appears imminent, stop work and notify Architect for a decision before resuming operations.
- B. Locations shown are approximate. The Plumbing Contractor shall refer to the architectural drawings for placement of equipment, fixtures, etc. Where locations are not clear, the Contractor shall obtain the exact locations from the Architect.
- C. Coordinate all exterior piping connections w/Architect, site contractor/plans. Verify manhole elevations and provide backwater valves as required if flood level rims are below next upstream manhole cover elevation. Fixtures with flood level rims above upstream manhole shall not discharge thru bow valve. Notify engineer of backwater valve requirement, any issues prior to bid.
- 1.4 SHOP DRAWINGS
- A. Shop drawings shall be submitted for plumbing fixtures and for pipe. These may consist of the manufacturer's standard catalog or tear sheets and shall have the exact items being offered clearly identified.
- PART 2 -- PRODUCTS
- 2.1 FIXTURES
- A. Each fixture shall be properly supported from the building structure as required to the end effect that all fixtures and accessories will be held rigidly in place. Water pipes supplying the fixtures must also be held rigidly in place.
- B. Provide loose key angle stops and chrome plated supply pipe water supplies to fixtures.
- C. All exposed piping traps and accessories for fixtures shall be chrome plated. Provide chrome plated escutcheon plates where pipes enter walls.
- D. Provide shutoff valves for all sinks, water heaters, toilets, washing machines, refrigerator ice-maker, exterior hose bibbs and all other plumbing fixtures.
- E. Provide trap primers for all floor drains in areas not served by hose bibbs.

- 2.2 PIPING
- A. Drain-Waste-Vent: All DWV piping shall be Schedule 40 PVC-DWV u.o.n., with the following exceptions: Use cast iron pipe in all return air plenums, penetrations of rated walls/floors/ceilings, and in areas/walls adjacent to cooking equipment exhaust hoods. Review Arch. and Mech. drawings. ABS or cast iron piping shall be used for drainage of effluent with a temperature greater than 140 deg. F for a minimum distance of 10'-0".
- B. Hot and cold water piping above grade: Type "L" copper w/solder joints (ASTM-B88), hard drawn with wrought copper fittings (ANSI B16.22). PEX piping with copper fittings may be used with owner/tenant approval and as allowed per code. Copper piping shall be used in areas/walls adjacent to cooking equipment exhaust hoods. Review Arch. and Mech. drawings.
- C. Cold water piping below grade: Type "K" copper (ASTM-B8A) soft drawn.
- D. Compressed air, vacuum piping-- see sheet P5.
- E. Hangers: Use pipe hangers where required on 8-foot centers with saddles to avoid crushing insulation.
- F. Solder: 95/5. Lead free.
- G. Unions: Provide unions where indicated on drawings, in long runs of piping (except drainage) and at equipment to provide convenient disassembly. Provide dielectric unions when connecting copper tubing to equipment and piping made of ferrous materials.
- 2.3 CLEANOUTS
- A. Hex plugs in rough areas: Recessed plugs with cover plates in exposed locations.
- 2.4 SHOCK ARRESTERS
- A. Provide shock arresters as required by codes, manufacturer's recommendations and accepted industry standards for quality construction. Provide for all quick closing valves.
- PART 3 -- EXECUTION
- 3.1 CONNECTIONS
- A. This contract includes complete connection of cold water, hot water, drainage, vent, air/gas piping as required. All fittings, valves, accessories, cutoffs, drains, etc., required to complete such connections shall be included.
- B. The connection to water closets shall be made watertight with gasket and wax ring. Floor flanges shall be caulked into position. Plastic caps shall be provided on the tie down bolts, and shall be secured in place by screwing down on threaded brass washers.
- C. Where water pipes connect to exposed chrome plated trim, use proper chrome plated escutcheons.
- 3.2 SERVICE ACCESS
- A. All valves and accessories shall be insulated so that they can be properly serviced. In no case shall the Plumbing Contractor install equipment or other components in situations that do not meet code requirements or manufacturer's requirements. Provide access doors to provide access valves, etc.
- 3.3 ROUTING OF PIPING
- A. Coordinate routing of piping with others, line up work true to or at right angle to adjacent surfaces and in a workmanlike manner. Support all interior piping from building structure by means of hanger or inserts to maintain pitch of lines, to prevent vibration, and to secure piping place.
- 3.7 SERVICE PRESSURE
- A. Provide approved water-pressure reducing valve (PRV) if service pressure exceeds 80 psi to reduce pressure to 80 psi static or less and as required per NCSBC-Plumbing Sect. 604.8.
- 3.8 DRAINDOWN
- A. Contractor to provide for complete plumbing system drain down.
- 3.9 CLEAN UP
- A. During construction, keep the site clear of debris and upon completion, and before final inspection, clean up the premises to remove all evidence of his work. In addition, upon completion of construction, clean, wash, and/or polish all fixtures, equipment and exposed material and leave them bright and clean.
- 3.10 GUARANTEES
- A. Guarantee all materials and labor included in the plumbing work for a period of one year from date of final acceptance by the Owner.
- B. Any defects in the system which become evident during the guarantee period shall be corrected without cost to the Owner. This shall include the replacing of defective materials where required, and the repair of damage caused by leaking pipes, etc., and damage to building surfaces caused in making repairs.

GENERAL NOTES -- PLUMBING

- 1. ALL WORK SHALL BE IN ACCORDANCE WITH THE LATEST EDITION OF THE STATE CODE, ALL LOCAL AND OTHER APPLICABLE CODES.
- 2. ALL WORK SHALL BE PERFORMED BY EXPERIENCED AND SKILLED CRAFTSMEN. THE PLUMBING CONTRACTOR (PC) SHALL COORDINATE ALL OF HIS WORK WITH THE GENERAL CONTRACTOR (GC).
- 3. THE PLUMBING PLANS AND SPECIFICATIONS SHALL BE THOROUGHLY REVIEWED PRIOR TO PURCHASING MATERIALS AND INSTALLATION AND ALL DISCREPANCIES OR INTERFERENCES BROUGHT TO THE ENGINEERS ATTENTION.
- 4. THESE PLANS ARE DIAGRAMMATIC AND MAY NOT SHOW MINOR DETAILS AND LOCATIONS. THE PC SHALL PROVIDE ALL MISC. ITEMS NEEDED FOR A COMPLETE SYSTEM REGARDLESS IF NOTED ON THE DRAWINGS OR NOT. FOR DIMENSIONS REFER TO ARCHITECTURAL PLANS.
- 5. THE GC SHALL PROVIDE ALL WALL, FLOOR AND ROOF OPENINGS OF THE SIZE AND LOCATION REQUIRED BY THE PC AND SHALL BE RESPONSIBLE FOR PAINTING AND FLOOR FINISHES. THE PC SHALL PROPERLY SEAL ALL PENETRATIONS AND PROVIDE ESCUTCHEON PLATES AT ALL FINISHED LOCATIONS.
- 6. ALL NEW WATER PIPING SHALL BE INSTALLED TIGHT TO STRUCTURE, ADEQUATELY SUPPORTED AND PROTECTED AND PROPERLY PITCHED TO ALLOW TOTAL DRAINAGE.
- 7. ALL WATER PIPING SHALL BE HYDROSTATICALLY TESTED FOR 2 -- HOURS AT 150 PSIG BEFORE COVERING AND ALL LEAKS CORRECTED. THE ENTIRE WATER DISTRIBUTION SYSTEM SHALL BE DISINFECTED PRIOR TO PLACING IN SERVICE.
- 8. PROVIDE MIN. 18" SHOCK ABSORBERS WITH STOPS ON ALL HOT AND COLD WATER FIXTURE RUNS AS REQUIRED BY CODE.
- 9. VENT LINES SHALL SLOPE UP TO ALL STACKS AND TERMINATE A MIN. OF 12" ABOVE ROOF LINE.
- 10. PROVIDE CUT SHEETS ON ALL PLUMBING FIXTURES FOR ARCHITECT AND OWNER APPROVAL PRIOR TO ORDERING ANY FIXTURES.
- 11. PROVIDE HOT WATER TO FIXTURES AT 110 (MAX.) DEGREES F.
- 12. PROVIDE CLEANOUTS AS REQUIRED BY CODE. NOT MORE THAN 100 FEET FOR 4" DRAIN.
- 13. PROVIDE CAST IRON PIPE PER PENETRATION SYSTEM DETAIL FOR ALL DWV PIPING THROUGH FIRE BARRIER WALLS/FLOORS/CEILING.

LOAD SUMMARY -- PLUMBING

WASTE DEMAND (FU)	WATER DEMAND (FU)	WATER DEMAND (GPM)
8.0	9.0	13.7

1 OMITTED SCALE: NOT TO SCALE

2 RPZ DETAIL SCALE: NOT TO SCALE

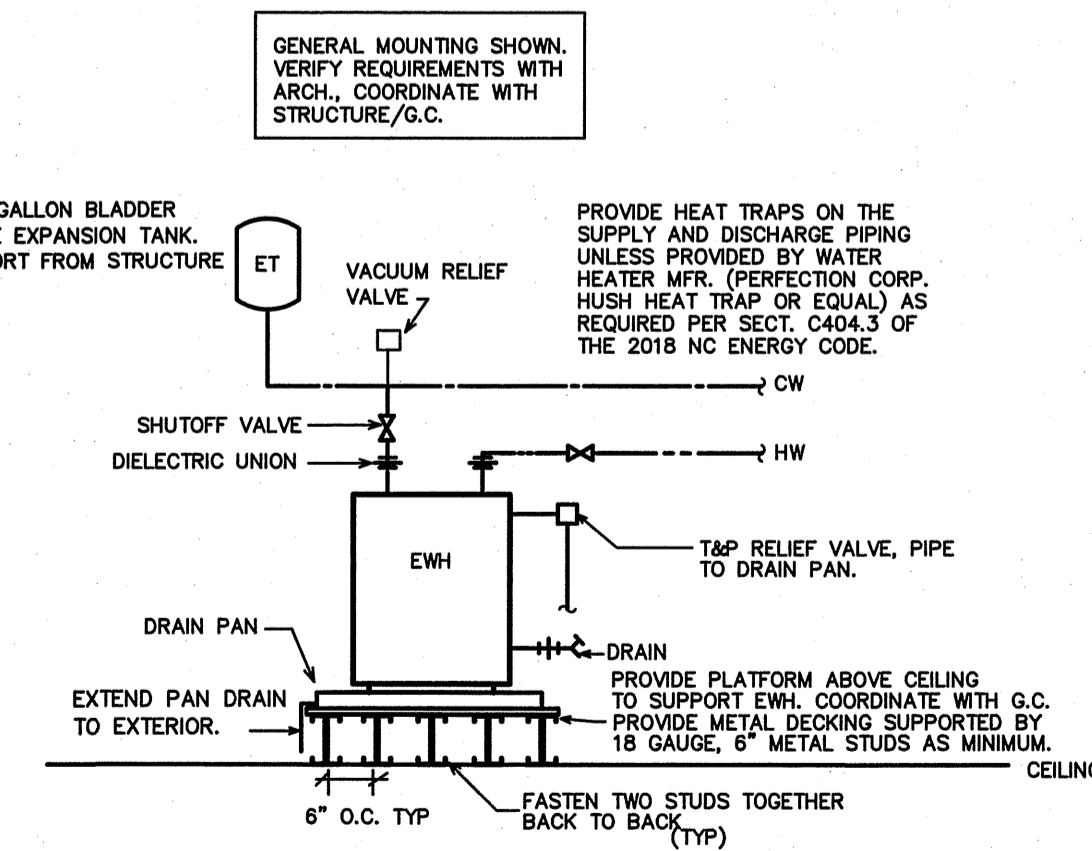

GENERAL MOUNTING SHOWN. VERIFY REQUIREMENTS WITH ARCH. COORDINATE WITH STRUCTURE/G.C.

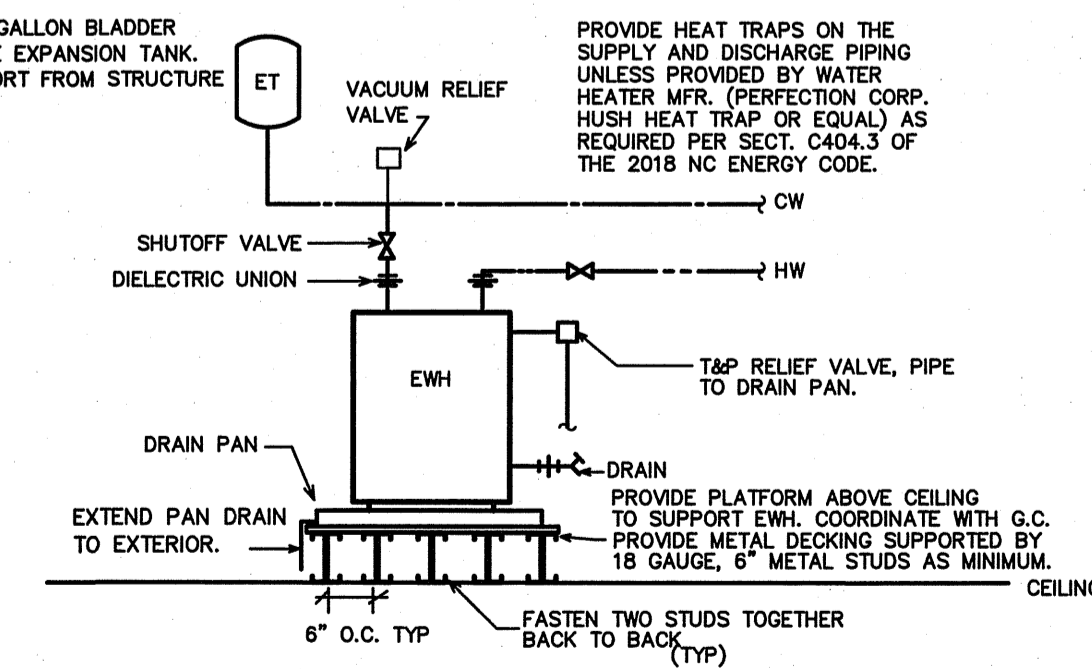

NOTE: WATER HEATERS, PIPING, AND PIPING APPURTENANCES PROVIDED BY P.C. WATER HEATER SUPPORTS BY P.C.

NOTE: PROVIDE LOW VOLTAGE WATER SENSOR (LITTLE GIANT HW-9 OR EQUAL) IN DRAIN PAN. MOUNT ALARM IN NOTICABLE AREA BELOW CEILING. COORDINATE ALARM LOCATION W/TENANT.

3 EWH DETAIL SCALE: NOT TO SCALE

WEEKS TURNER ARCHITECTURE

WEEKS TURNER ARCHITECTURE, PA  
3305-109 Durham Drive  
Raleigh, North Carolina 27603  
919.779.9797 fax: 919.779.0826  
www.weeksturmer.com

ENGINEER  
BURKE DESIGN GROUP, PA  
CONSULTING ENGINEERS  
3305-109 Durham Drive  
Raleigh, North Carolina 27603  
919.771.1916 fax: 919.779.0826  
email: benburke@ncr.com  
Corp. License # C-2652

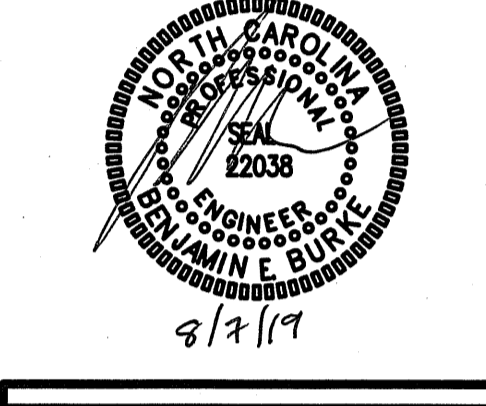

PROJECT TITLE  
DAWSON ELECTRIC

280 JARCO DR  
FUQUAY VARINA, NC 27526

PROJECT NO.  
1918

DRAWING TITLE  
FLOOR PLAN

P1

PLOT DATE 7/19/2019

This original sheet is 24" x 36", other dimensions indicate it has been altered.  
All information on this sheet is the property of Weeks Turner Architecture and may not be duplicated, in whole or in part without written authorization from Weeks Turner Architecture, 2019

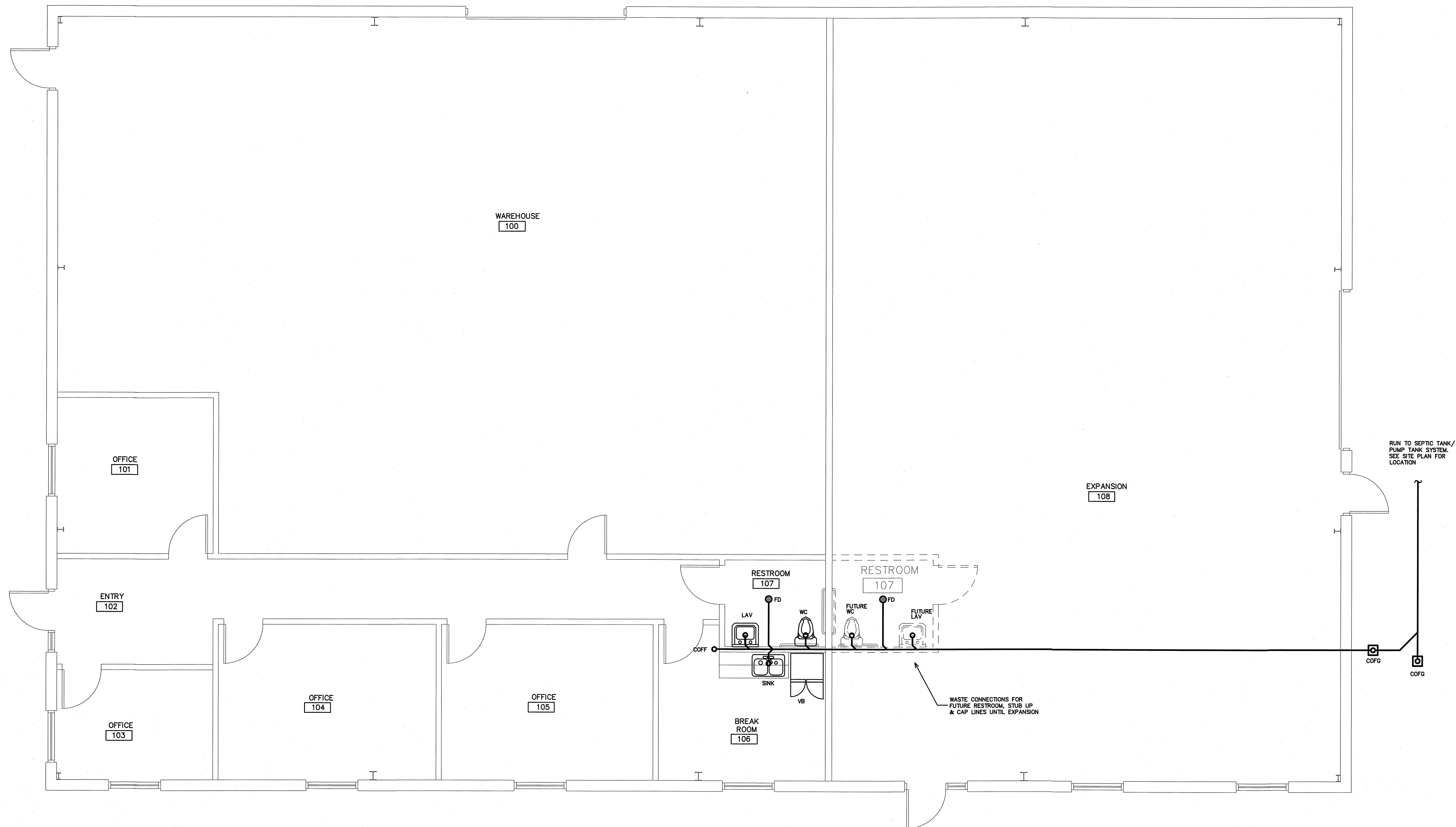

1 DWV PLAN  
SCALE: 1/4" = 1'-0"

PROJECT TITLE  
**DAWSON ELECTRIC**

280 JARCO DR  
FUQUAY VARINA, NC 27526

PROJECT NO.  
**1918**

DRAWING TITLE  
**DWV PLAN**

**P2**

PLOT DATE 7/19/2019

This original sheet is 24" x 36"; other dimensions indicate it has been altered.  
All information on this sheet is the property of Weeks Turner Architecture and may not be duplicated in whole or in part without written authorization from Weeks Turner Architecture, 2019

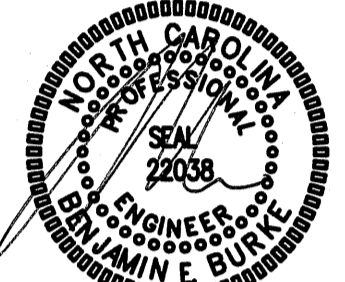

8/3/19

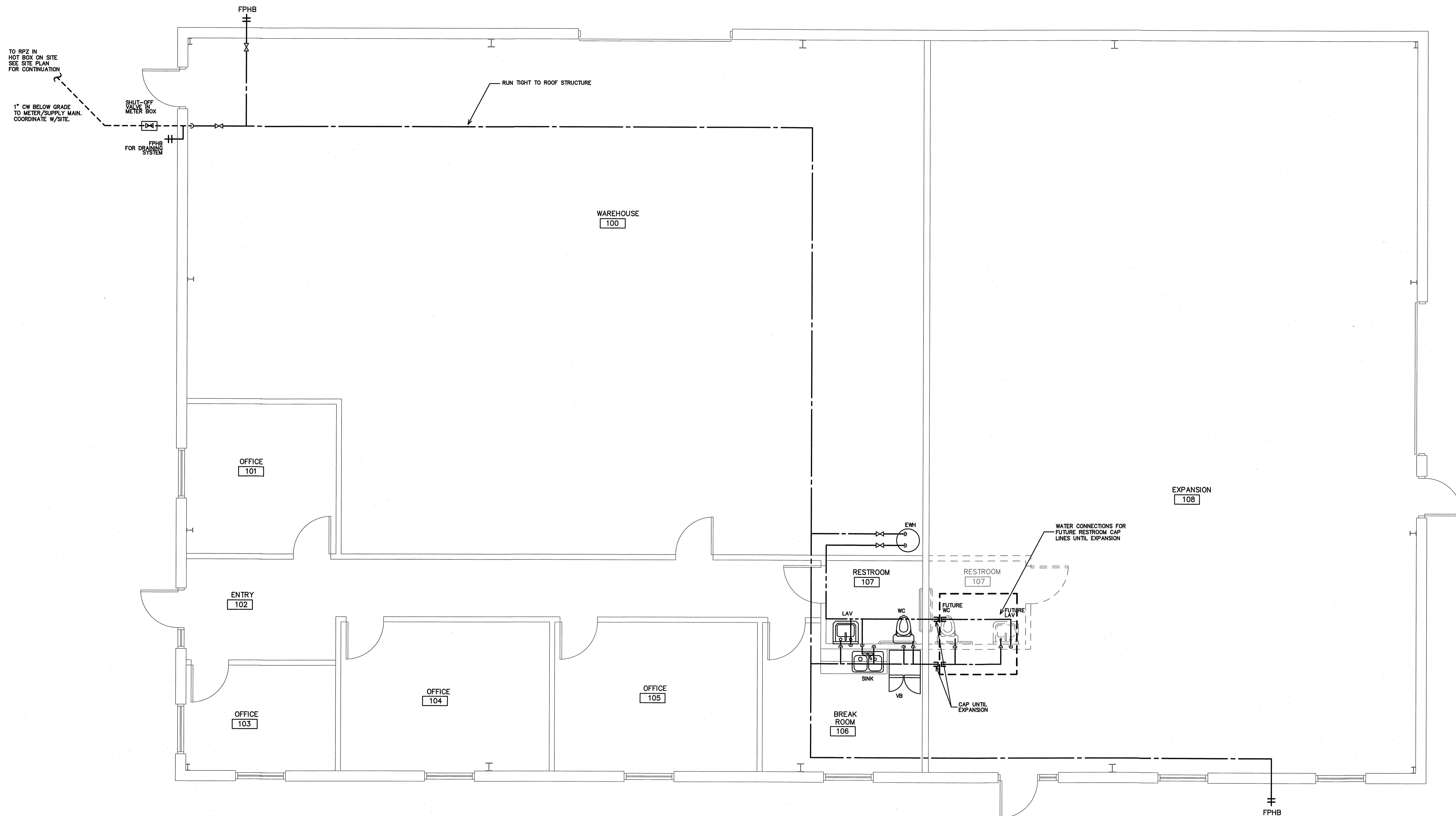

**1** SUPPLY PLAN  
SCALE: 1/4" = 1'-0"

PROJECT TITLE  
**DAWSON ELECTRIC**

280 JARCO DR  
FUQUAY VARINA, NC 27526

PROJECT NO.  
**1918**

DRAWING TITLE  
**SUPPLY PLAN**

**P3**

PLOT DATE 7/19/2019

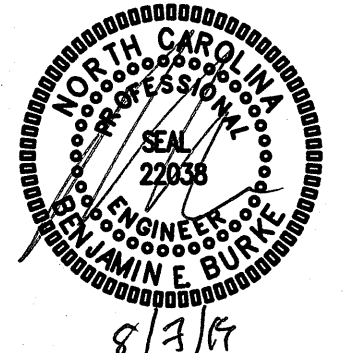

( VERIFY ALL EQUIPMENT REQUIREMENTS PRIOR TO ROUGH-IN )

PIPE SIZING SCHEDULE				
FIXTURE TYPE	DRAIN	VENT	CW	HW
(FD) FLOOR DRAIN	3"	1 1/2"	-	-
(FPHB) FREEZE PROOF HOSE BIBB	-	-	1/2"	-
(L) LAVATORY	1 1/2"	1 1/4"	1/2"	1/2"
(S) SINK	1 1/2"	1 1/4"	1/2"	1/2"
(VB) VALVE BOX	-	-	1/2"	*
(WC) FLUSH TANK WATER CLOSET	3"	1 1/2"	1/2"	-

\* PROVIDE BACKFLOW PREVENTER PER NCSBO-PLUMBING SECT. 608.3, ASSE 1024 (WATTS SERIES 7 OR EQUAL) OR ASSE 1022 (WATTS SERIES SD-3 OR EQUAL) WHERE REQUIRED IF NOT AN INTEGRAL PART OF THE EQUIPMENT.

RISER NOTES:  
REPRESENTATIVE SIZES ARE GIVEN FOR EACH TYPE OF FIXTURE. SEE PIPE SIZING SCHEDULE.  
MINIMUM 2" DRAIN LINE SIZE UNDER SLAB.  
MAINTAIN PIPE SIZES SHOWN UNTIL LARGER SIZE IS REACHED.  
PIPE SIZES ARE MINIMUMS FOR INDIVIDUAL FIXTURES U.O.N.

NOTE:  
PROVIDE PROPER VENT THRU ROOF (VTR).  
RUN HORIZONTALLY AS REQUIRED TO  
MAINTAIN 10'-0" CLEARANCE FROM ANY  
INTAKES. PROPERLY FLASH ANY ROOF  
PENETRATION. (TYP)

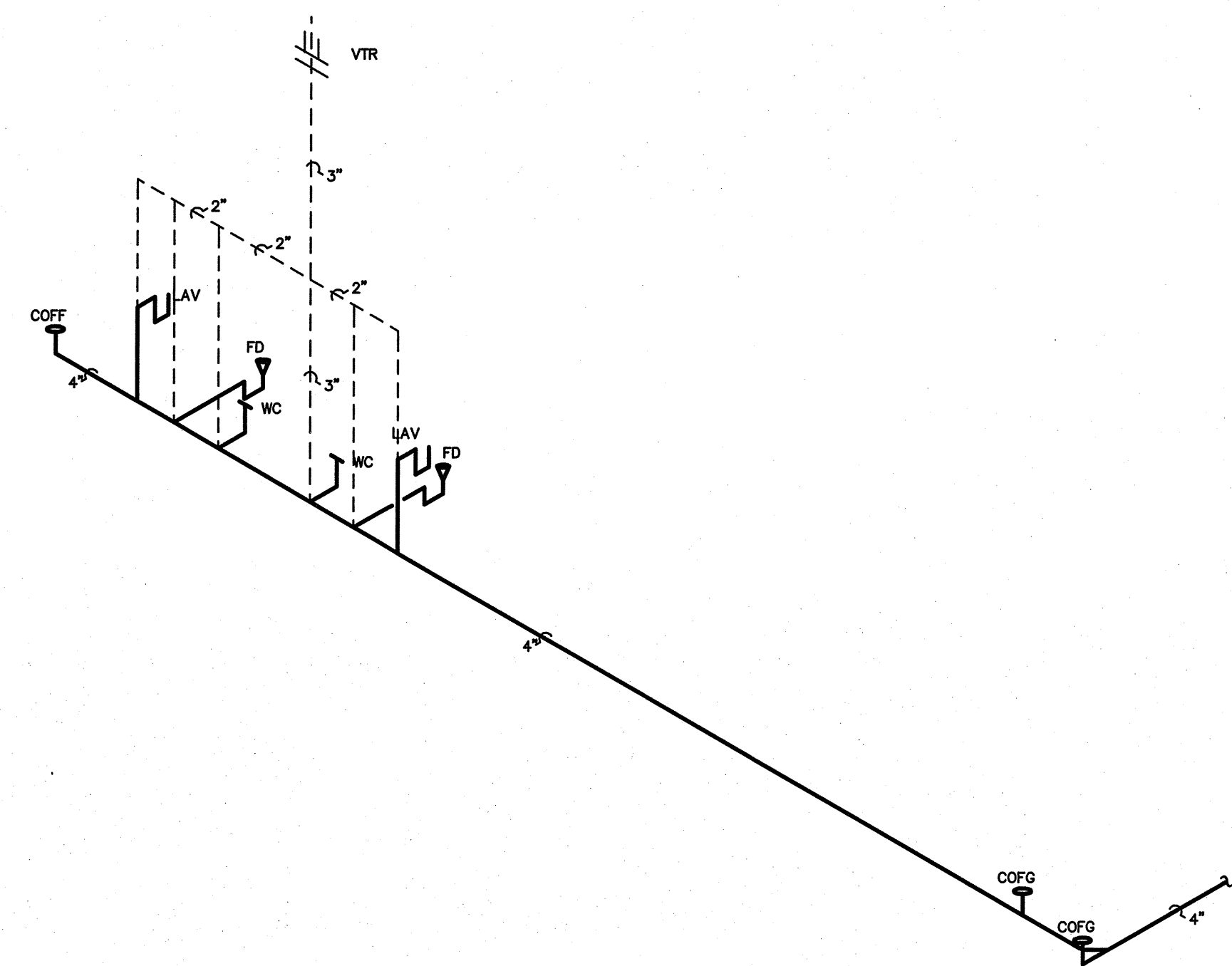

1 DWV RISER  
SCALE: NOT TO SCALE

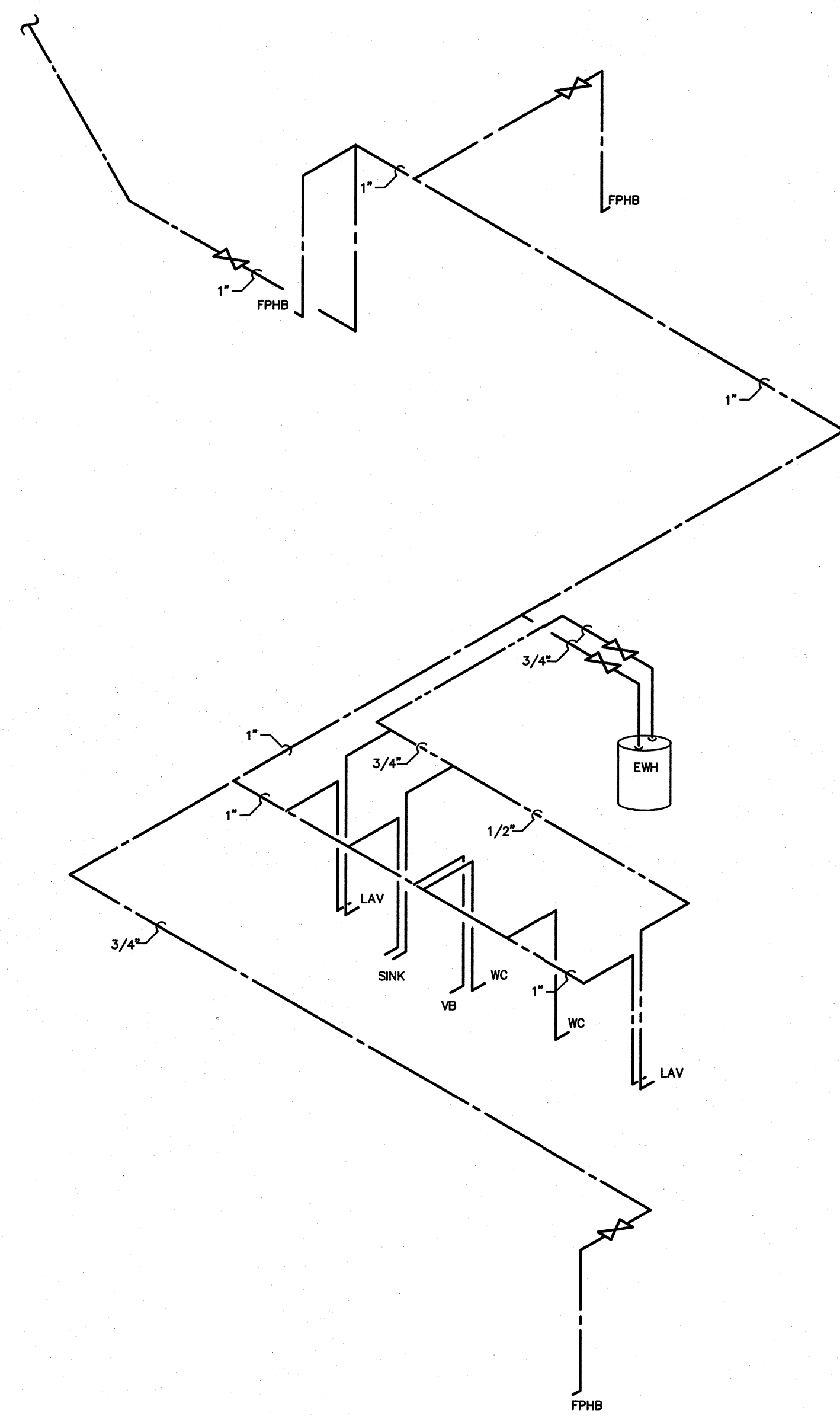

1 SUPPLY RISER  
SCALE: NOT TO SCALE

PROJECT TITLE  
**DAWSON ELECTRIC**

280 JARCO DR  
FUQUAY VARINA, NC 27526

PROJECT NO.  
**1918**

DRAWING TITLE  
**PLUMBING RISERS**

**P4**

PLOT DATE 7/19/2019