

ES-50X

Intelligent Addressable FACP with Communicator



Addressable Fire Alarm Control Panels

General

The **ES-50X** is the latest intelligent addressable fire alarm control panel (FACP) from Fire-Lite Alarms and is a direct replacement for the MS-9050UD/LS. The ES-50X comes with a pre-installed communicator and supports up to 50 addressable devices in any combination of detectors or modules. With an extensive list of powerful features, the ES-50X programs just like Fire-Lite's other addressable panels, yet fits into applications previously served only by conventional panels.

The pre-installed IPOTS-COM is a dual technology (POTS and IP) communicator. The POTS transmits system status (alarms, troubles, AC loss, etc.) to a Central Station via the public switched telephone network. The IP communicator's internet monitoring capability sends alarm signals over the Internet saving the monthly cost of two dedicated business telephone lines. Although not required, the secondary telephone line may be retained providing backup communication over the public switched telephone line. Optional cellular reporting is available using the CELL-MOD or CELL-CAB-FL.

Remote and local programming of the control panel is possible using the FS-Tools Upload/Download utility. Programming databases can be uploaded/downloaded via the panel's USB port (and USB cable) or via an ethernet connection using the IPOTS-COM communicator. The USB port also allows for the download or upload of the entire program, history file, walk-test data, current status and system voltages by means of a USB flash drive.

The power supply and all electronics are contained on a circuit board supported on a new quick install chassis and housed in a metal cabinet. Available accessories include local and remote upload/download software, remote annunciators, and reverse polarity/city box transmitter (4XTMF).

Features

- Listed to UL Standard 864, 10th edition
- Pre-installed IPOTS-COM Ethernet IP and POTS (Plain Old Telephone Service) Central Station Communicator
- Optional CELL-MOD or CELL-CAB-FL GSM Central Station Communicator over AlarmNet®
- Compatible with SWIFT® wireless devices
- Auto-programming (learn mode) reduces installation time. Reports two devices set to the same address
- Two independently programmable, built-in Style Z (Class A) or Style Y (Class B) NAC circuits
- Selectable strobe synchronization for System Sensor, Wheelock, and Gentex devices
- Notification Appliance Circuit End of Line resistor matching
- Four programmable function keys for ease of maintenance
- Two programmable relays and one fixed trouble relay
- Built-in Programmer
- Integral 80-character LCD display with backlighting
- Real-time clock/calendar with automatic daylight savings control
- History file with 1,000 event capacity
- Addressable sounder base
- Multi-criteria detector (smoke, heat, CO) with programmable response
- Control module delay timer
- Automatic detector sensitivity testing (NFPA 72 compliant)
- Automatic device type-code verification
- Point trouble identification
- Waterflow selection per module point
- Alarm verification selection per detector point

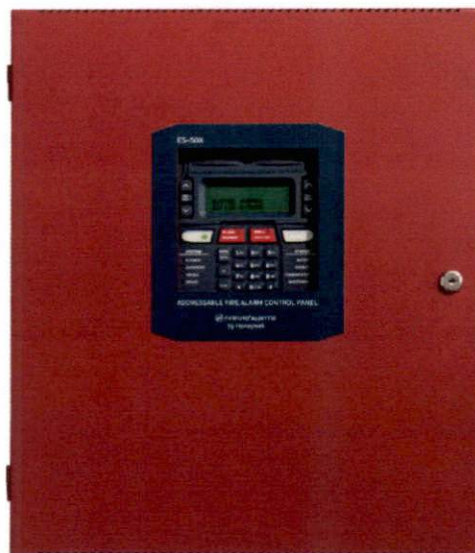

- Maintenance alert warns when smoke detector dust accumulation is excessive
- One-person audible or silent walktest with walktest log & printout
- System alarm verification selection per detector point
- PAS (Positive Alarm Sequence) and Pre-signal per point (NFPA 72 compliant)
- Up to 16 ANN-BUS annunciators- 8 per each ANN-Bus
- Remote Acknowledge, Alarm Silence, Reset and Drill via addressable modules or remote annunciator
- Upload/Download of program and data via USB with optional FS-Tools Programming Utility

SLC COMMUNICATION LOOP

- Supports LiteSpeed™ and CLIP protocols
- SLC operates up to 10,000 ft. (3,000 m) in LiteSpeed mode with twisted, unshielded wire
- Single addressable SLC loop which meets NFPA Class B and Class A requirements
- 50 addressable device capacity (any combination of addressable detectors and modules)
- Compatible with Fire-Lite's addressable devices (refer to the *SLC Wiring Manual*)

NOTIFICATION APPLIANCE CIRCUITS (NACS)

- Two independently programmable output circuits. Circuits can be configured for the following outputs:
 - Style Y (Class B)
 - Style Z (Class A)
 - Silence Inhibit and Autosilence timer options
 - Continuous, March Time, Temporal, or California code for main circuit board NACs with two-stage capability
 - Selectable strobe synchronization per NAC
 - 2.5 A special application, 250mA regulated, total power for NACs
- NOTE:** Maximum or total 24VDC system power shared between all NAC circuits and the ANN-BUS is 2.7 A

PROGRAMMING AND SOFTWARE

- Autoprogramming (learn mode) reduces installation time

- Custom English labels (per point) may be manually entered or selected from an internal library file
- Two programmable Form-C relay outputs
- 50 software zones
- Continuous fire protection during online programming
- Program Check automatically catches common errors not linked to any zone or input point
- **OFFLINE PROGRAMMING:** Create the entire program in your office using FS-Tools, a Windows®-based software package, and upload/download system programming locally. Offline programming requires an ethernet connection. FS-Tools is available on www.firelite.com.

User interface

LED INDICATORS

- Fire Alarm (red)
- CO Alarm (red)
- AC Power (green)
- Supervisory (yellow)
- Trouble (yellow)
- Ground fault (yellow)
- Battery fault (yellow)
- Disabled (yellow)
- Maintenance (yellow)
- Communication (yellow)
- Alarm Silenced (yellow)
- F1-F4 Programmable Function Keys (yellow)

KEYPAD

- 16 key alpha-numeric pad
- Acknowledge
- Alarm Silence
- Drill (Manual Evacuate)
- Four (4) programmable function keys
- Reset (lamp test)

Product Line Information

ES-50X: Addressable Fire Alarm Control Panel with one SLC loop. Includes main circuit board with display, pre-installed IPOTS-COM communicator, chassis with transformer, backbox with door, plastic bag containing screws, cables, key, etc. (For ES-50XC, refer to DF-60954.)

FS-Tools: Programming software for Windows®-based PC computer. Available for download at www.firelite.com.

CELL-CAB-FL/CELL-MOD: Optional GSM communicators.

IPOTS-COM: Dual technology (POTS and IP) communicator. (replacement board)

DP-ES-R: Optional dress panel for the ES-50X.

TR-CE: Optional trim ring for semi-flush mounting.

BB-2F: Optional cabinet for one or two modules.

BB-6F: Optional cabinet for up to six modules mounted on CHS-6 chassis.

BB-26: Battery backbox, holds up to two 25 AH batteries & CHG-75.

BB-55F: Battery box, houses two 55 AH batteries

CHS-6: Chassis, mounts up to six multi-modules in a BB-6F cabinet.

CHG-75: Battery charger for lead-acid batteries with a rating of 25 to 75 AH.

CHG-120F: Remote battery charging system for lead-acid batteries with a rating of 55 to 120 AH. Requires additional BB-55F for mounting.

BAT Series: Batteries, see data sheet DF-52397.

PRN Series: UL listed compatible event printer. Uses tractor-fed paper.

OPTIONAL MODULES

4XTMF Reverse Polarity Transmitter Module: Provides a supervised output for local energy municipal box transmitter, alarm and trouble. Includes a disable switch and disable trouble LED.

COMPATIBLE ANNUNCIATORS

ANN-80: Remote, red LCD annunciator mimics the information displayed on the FACP LCD display. Recommended wire type is unshielded.

ANN-100: Remote LCD annunciator mimics the information displayed on the FACP LCD display. Recommended wire type is unshielded. For use in FM applications only.

ANN-IO: LED Driver Module provides connections to a user supplied graphic annunciator. (See DF-52430.)

ANN-LED: Annunciator Module provides three LEDs for each zone: Alarm, Trouble, and Supervisory. Ships with red enclosure. (See DF-60241.)

ANN-RLED: Provides alarm (red) indicators for up to 30 input zones or addressable points. (See DF-60241.)

ANN-RLY: Relay Module provides 10 programmable Form-C relays. Can be mounted inside the cabinet. (See DF-52431.)

ANN-S/PG: Serial/Parallel Printer Gateway module provides a connection for a serial or parallel printer. (See DF-52429.)

ADDRESSABLE DEVICES

All feature a polling LED and rotary switches for addressing.

SD365: Addressable low-profile photoelectric smoke detector. LiteSpeed only.

SD365-IV: Addressable low-profile photoelectric smoke detector. Ivory. LiteSpeed and CLIP mode.

SD365T: Addressable low-profile photoelectric smoke detector with thermal sensor. LiteSpeed only.

SD365T-IV: Addressable low-profile photoelectric smoke detector with thermal sensor. Ivory. LiteSpeed and CLIP mode.

SD365R: Remote test capable addressable photoelectric smoke detector for use with DNR(W) duct detector housing. LiteSpeed only.

SD365R-IV: Remote test capable addressable photoelectric smoke detector for use with DNR(W) duct detector housing. Ivory. LiteSpeed and CLIP mode.

H365: Low-profile 135°F fixed thermal sensor. LiteSpeed only.

H365-IV: Low-profile 135°F fixed thermal sensor. Ivory. LiteSpeed and CLIP mode.

H365R: Low-profile, intelligent, rate-of-rise thermal sensor. LiteSpeed only.

H365R-IV: Low-profile, intelligent, rate-of-rise thermal sensor. Ivory. LiteSpeed and CLIP mode.

H365HT: Low-profile intelligent 190°F/88°C fixed thermal sensor. LiteSpeed only.

H365HT-IV: Low-profile intelligent 190°F/88°C fixed thermal sensor. Ivory. LiteSpeed and CLIP mode.

Legacy Devices

SD355: Addressable low-profile photoelectric smoke detector.

SD355T: Addressable low-profile photoelectric smoke detector with thermal sensor.

SD355R: Remote test capable addressable photoelectric smoke detector for use with DNR(W) duct detector housing.

SD355CO: Addressable, low-profile device that provides fire, heat, and carbon monoxide (CO) detection.

H355: Fast-response, low-profile heat detector.

H355R: Fast-response, low-profile heat detector with rate-of-rise option.

H355HT: Fast-response, low-profile heat detector that activates at 190°F/88°C.

AD355: Low-profile, intelligent, "Adapt" multi-sensor detector (B350LP base included).

B200S: Programmable, addressable sounder base

B200SR: Addressable sounder base.

BEAM355: Intelligent beam smoke detector.

BEAM355S: Intelligent beam smoke detector with integral sensitivity test.

D355PL: InnovairFlex low-flow non-relay duct-detector housing; includes SD355R.

DNR: InnovairFlex low-flow non-relay duct-detector housing. (Order SD355R/SD365R separately.)

DNRW: InnovairFlex low-flow non-relay duct-detector housing, with NEMA-4 rating. Watertight. (Order SD355R/SD365R separately.)

Addressable Modules

MMF-300: Addressable Monitor Module for one zone of normally-open dry-contact initiating devices. Mounts in standard 4.0" (10.16 cm.) box. Includes plastic cover plate and end-of-line resistor. Module may be configured for either a Style B (Class B) or Style D (Class A) IDC.

MDF-300: Dual Monitor Module. Same as MMF-300 except it provides two Style B (Class B) only IDCs.

MMF-301: Miniature version of MMF-300. Excludes LED and Style D option. Connects with wire pigtails. May mount in device backbox.

MMF-302: Similar to MMF-300. Addressable Monitor Module for one zone of conventional two-wire detectors. Requires resettable 24 VDC power. Refer to the *Device Compatibility Document* for listed compatible devices and quantity limitation.

CMF-300: Addressable Control Module for one Style Y/Z (Class B/A) zone of supervised polarized Notification Appliances. Mounts directly to a 4.0" (10.16 cm.) electrical box. NAC option requires external 24 VDC to power notification appliances.

CRF-300: Addressable relay module containing two isolated sets of Form-C contacts, which operate as a DPDT switch. Mounts directly to a 4.0" (10.16 cm.) box, surface mount using the SMB500.

BG-12LX: Addressable manual pull station with interface module mounted inside.

I300: This module isolates the SLC loop from short circuit conditions (required for Style 6 or 7 operation).

ISO-6: Six-fault isolator module. Mount one or two modules in a BB-2F cabinet (optional). Mount up to six modules on a CHS-6 chassis in a BB-6F cabinet.

SMB500: Used to mount all modules except MMF-301 and M301.

MMF-300-10: Ten-input monitor module. Mount one or two modules in a BB-2F cabinet (optional). Mount up to six modules on a CHS-6 chassis in a BB-6F cabinet.

MMF-302-6: Six-zone interface module. Mount one or two modules in a BB-2F cabinet (optional). Mount up to six modules on a CHS-6 chassis in a BB-6F cabinet.

CMF-300-6: Six-circuit supervised control module. Mount one or two modules in a BB-2F cabinet (optional). Mount up to six modules on a CHS-6 chassis in a BB-6F cabinet.

CRF-300-6: Six-relay control module (Form-C relays). Mount one or two modules in a BB-2F cabinet (optional). Mount up to six modules on a CHS-6 chassis in a BB-6F cabinet.

SWIFT Wireless Devices

W-GATE: LiteSpeed Wireless Gateway

W-SD355: LiteSpeed intelligent, wireless photo detector.

W-H355R: LiteSpeed intelligent wireless rate of rise (135°) heat detector.

W-SD355T: intelligent wireless photo/heat detector.

W-H355: LiteSpeed intelligent wireless fixed-temperature (135°) heat detector.

W-MMF: LiteSpeed Intelligent wireless monitor module.

W-CRF: LiteSpeed Intelligent wireless relay module.

W-BG12LX: LiteSpeed Intelligent wireless pull station.

WAV-RL, WAV-WL, WAV-CRL, WAV-CWL: LiteSpeed Intelligent AV bases.

W-USB: Wireless USB radio/antenna dongle that plugs into the USB port of a PC running SWIFT Tools.

SWIFT Tools: Programming and diagnostic utility for the Wireless Gateway and devices. Available for download from firelite.com.

NOTE: For more information on Compatible Addressable Devices for use with the ES-50X, see the following data sheets (document numbers): SD365 Series (DF-61010), H365 Series (DF-61011), AD355 (DF-52386), BG-12LX (DF-52013), CMF-300-6 (DF-52365), CRF-300-6 (DF-52374), CMF/CRF Series (DF-52130), CP355 (DF-52383), H355 Series (DF-52385), I300 (DF-52389), ISO-6 (DF-60485), MMF-300 Series/MDF-300 (DF-52121), MMF-300-10 (DF-52347), MMF-302-6 (DF-52356), SD355/SD355T (DF-52384), and SLC Wiring Manual (51309).

NOTE: Legacy 300 Series detection devices such as the CP300/CP350, SD300(T)/SD350(T) and older modules such as the M300, M301, M302, C304, and BG-10LX are not compatible with LiteSpeed polling. If the SLC contains one of these devices, polling must be set for standard CLIP protocol. Please consult factory for further information on previous 300 Series devices.

ADDRESSABLE DEVICE ACCESSORIES

End-of-Line Resistor Assembly (R-47K and R-3.9K): The 47k ohm assembly supervises the MMF-300, MDF-300, MMF-301, and CMF-300 module circuits. The 3.9k ohm assembly supervises the MMF-302 module circuit. These resistors are included with each module.

Power Supervision Relay: Supervises the power to 4-wire smoke detectors and notification appliances.

Wiring Requirements

While shielded wire is not required, it is recommended that all SLC wiring be twisted-pair to minimize the effects of electrical interference. Refer to the panel manual for wiring details.

SYSTEM SPECIFICATIONS

System Capacity

• Intelligent Signaling Line Circuits.....	1
• Addressable device capacity.....	50
• Programmable software zones.....	50
• Annunciators.....	16

Electrical Specifications

AC Power: Operates in either 120 or 240 VAC, 50/60 Hz, 3.25 A, auto-sensing- no switch required. Wire size: minimum 14 AWG (2.00 mm²) with 600 V insulation. Nonpower-limited, supervised.

Battery: Two 12 V 18 AH lead-acid batteries. Battery Charger Capacity: 7-18 AH (ES-50X cabinet holds maximum of two 18 AH batteries.)

Communication Loop: Supervised and power-limited.

Notification Appliance Circuits: Terminal Block provides connections for two NACs, Style Y (Class B) or Style Z (Class A). Special Application power. Power-limited, supervised circuitry. Maximum signaling current per circuit: 2.5 amps special application, 250mA regulated. End-of-Line Resistor: 4.7k ohm, ½ watt (P/N 71252 UL listed) for Style Y (Class B) NAC; system capable of 1.9 kΩ - 22 kΩ ELR range. Refer to the *Fire-Lite Device Compatibility Document* for listed compatible devices.

Two Programmable Relays and One Fixed Trouble Relay: Contact rating: 2.0 A @ 30 VDC (resistive), 0.5 A @ 30 VAC (resistive). Form-C relays, non-power-limited, non-supervised.

Cabinet Specifications

Door: 19.26" (48.92 cm.) high x 16.82" (42.73 cm.) wide x 0.72" (1.82 cm.) deep. **Backbox:** 19.00" (48.26 cm.) high x 16.65" (42.29 cm.) wide x 5.25" (13.34 cm.) deep. **Trim Ring (TR-CE):** 22.00" (55.88 cm.) high x 19.65" (49.91 cm.) wide.

Shipping Specifications

Weight: 26.9 lbs. (12.20 kg.) **Dimensions:** 20.00" (50.80 cm.) high x 22.5" (57.15 cm.) wide x 8.5" (21.59 cm.) deep.

Temperature and Humidity Ranges

This system meets NFPA requirements for operation at 0 – 49°C/32 – 120°F and at a relative humidity 93% ± 2% RH (noncondensing) at 32°C ± 2°C (90°F ± 3°F). However, the useful life of the system's standby batteries and the electronic components may be adversely affected by extreme temperature ranges and humidity. Therefore, it is recommended that this system and its peripherals be installed in an environment with a normal room temperature of 15 – 27°C/60 – 80°F.

NFPA Standards

The ES-50X complies with the following NFPA 72 Fire Alarm Systems requirements:

- **LOCAL** (Automatic, Manual, Waterflow and Sprinkler Supervisory).
- **AUXILIARY** (Automatic, Manual and Waterflow) (requires 4XTMF).
- **REMOTE STATION** (Automatic, Manual and Waterflow) (Where a DACT is not accepted, the alarm, trouble and supervisory relays may be connected to UL 864 listed transmitters. For reverse polarity signaling of alarm and trouble, 4XTMF is required.)
- **PROPRIETARY** (Automatic, Manual and Waterflow).
- **CENTRAL STATION** (Automatic, Manual and Waterflow, and Sprinkler Supervised).
- **OT, PSDN** (Other Technologies, Packet-switched Data Network)
- **IBC 2012, IBC 2009, IBC 2006, IBC 2003, IBC 2000** (Seismic).
- **CBC 2007** (Seismic)

Agency Listings and Approvals

The listings and approvals below apply to the basic ES-50X control panel. In some cases, certain modules may not be listed by certain approval agencies, or listing may be in process. Consult factory for latest listing status.

- **UL:** S624
- **FM approved**
- **CSFM:** 7165-0075:0500
- **FDNY:** COA #6261

NOTE: See DF-60954 for ULC-listed model.

AlarmNet®, Fire-Lite® Alarms, SWIFT®, and System Sensor® are registered trademarks of Honeywell International Inc. Microsoft® and Windows® are registered trademarks of the Microsoft Corporation.
©2018 by Honeywell International Inc. All rights reserved. Unauthorized use of this document is strictly prohibited.



This document is not intended to be used for installation purposes.
We try to keep our product information up-to-date and accurate.
We cannot cover all specific applications or anticipate all requirements.
All specifications are subject to change without notice.

For more information, contact Fire-Lite Alarms. Phone: (800) 627-3473, FAX: (877) 699-4105.
www.firelite.com



Country of Origin: USA

FCPS-24FS8(C/E)

**8 Amp, 24 Volt
Remote Power Supply**

 **FIRE-LITE Alarms**
by Honeywell

Power Supplies

The Fire-Lite FCPS-24FS8(C/E) is a compact, cost-effective, 8-amp remote power supplies with battery charger. The FCPS-24FS8(C/E) may be connected to any 12 or 24 volt fire alarm control panel (FACP) or may stand-alone. Primary applications include notification appliance (bell) circuit (NAC) expansion (to support ADA requirements and NAC synchronization) or auxiliary power to support 24 volt system accessories. The FCPS provides *regulated and filtered* 24 VDC power to four notification appliance circuits configured as either two Class B (Style Y) and Class A (Style Z, with ZNAC-4 option module) or four class B only. Alternately, the four outputs may be configured as any combination of resettable/non-resettable power outputs (optimal for powering four-wire smoke detectors). The FCPS-24FS8(C/E) also contains a battery charger capable of charging up to 18.0 Amp hour batteries. The FCPS-24FS8C is ULC-listed.

NOTE: Unless otherwise specified, the term FCPS-24FS8 used in this document refers to the FCPS-24FS8, FCPS-24FS8C, and FCPS-24FS8E.

Features

- UL-Listed Notification Appliance Circuit (NAC) synchronization using System Sensor®, Wheelock®, or Gentex® "Commander2" appliances
- Operates as a "sync-follower" or as a "sync-generator" (default)
See note on page 2.
- Contains two fully-isolated input/control circuits - triggered from FACP NAC (NAC expander mode) or jumped permanently "ON" (stand-alone mode)
- Two Class B (Style Y) or Class A (Style Z, with ZNAC-4 module) NACs (circuits 1 & 3)
- 8-amp full load output, with 3 amps maximum/circuit, in NAC expander mode (UL 864)
- 6-amp continuous output in stand-alone mode (UL 1481)
- Compatible with coded inputs; signals passed through
- Optional power-supervision relay (EOLR-1)
- In stand-alone mode, output power circuits may be configured as: resettable, (reset line from FACP required), non-resettable, or a mix of two and two
- Fully regulated and filtered power output - optimal for powering four-wire smoke detectors, annunciators, and other system peripherals requiring regulated/filtered power
- Power-limiting technology meets UL power-limiting requirements.
- Form-C normally-closed trouble relay
- Fully supervised power supply, battery, and NACs
- Selectable earth fault detection
- AC trouble report selectable for immediate 2-hour delay
- Works with virtually any UL 864 fire alarm control which utilizes an industry-standard reverse-polarity notification circuit (including unfiltered and unregulated bell power)
- Requires input trigger voltage of 9 - 32 VDC
- Self-contained in compact, locking cabinet - 15"H x 14.5"W x 2.75"D (cm: 38.1H x 36.83W x 6.985D)
- Includes integral battery charger capable of charging up to 18 AH batteries. Cabinet capable of housing 7.0 AH batteries
- Battery charger may be disabled via DIP switch for applications requiring larger batteries
- Fixed, clamp-type terminal blocks accommodate up to 12 AWG (3.1mm²) wire



Specifications

Primary (AC) Power:

- FCPS-24FS8/C: 120 VAC, 60 Hz, 3.2A maximum
- FCPS-24FS8E: 240 VAC, 50 Hz, 1.6A maximum
- Wire Size: minimum #14 AWG (2.0mm²) with 600 V insulation

Control Input Circuit:

- **Trigger Input Voltage:** 9 to 32 VDC
- **Trigger Current:** 2.0 mA (16 - 32 V); Per Input: 1.0 mA (9 - 16 V)

Trouble Contact Rating: 5 A at 24 VDC

Auxiliary Power Output: Special application power 500 mA maximum

Output Circuits:

- +24 VDC filtered, regulated
- 3.0 A maximum for any one circuit
- Total continuous current for all outputs (stand-alone mode): 6.0 A maximum
- Total short-term current for all outputs (NAC expander mode): 8.0 A maximum

Secondary Power (Battery) Charging Circuit:

- Supports lead-acid batteries only
- Float-charge voltage: 27.6 VDC
- Maximum current charge: 250 mA
- Maximum battery capacity: 7.0 AH

Applications

Example 1: Expand notification appliance power an additional 8 amps. Use up to four Class B (Style Y) outputs or four Class A (Style Z) outputs (using ZNAC-4). For example, the FACP notification appliance circuits will activate the FCPS when reverse-polarity activation occurs. Trouble conditions on the FCPS are sensed by the FACP through the notification appliance circuit.

Example 2: Use the FCPS to expand auxiliary regulated 24-volt system power up to 6 amps. Both resettable and non-resettable power options are available. Resettable outputs are created by connecting the resettable output from the FACP to one or both of the FCPS inputs.

Example 3: Use addressable control modules to activate the FCPS instead of activating it through the FACP notification appliance circuits. This typically allows for mounting the FCPS at greater distances* away from the FACP while expanding system architecture in various applications.

For example, an addressable control module is used to activate the FCPS, and an addressable monitor module is used to sense FCPS trouble conditions. Local auxiliary power output from the FCPS provides power to the addressable control module.

***NOTE:** Addressable FACP's are capable of locating control and monitor modules at distances of up to 10,000 feet (3,046 meters).

Sync Follower/Generator Note

In some installations, it is necessary to synchronize the flash timing of all strobes in the system for ADA compliance. Strobes accomplish this by monitoring very short timing pulses on the NAC power which are created by the FACP. When installed at the end of a NAC wire run, the FCPS-24FS8 can track (i.e. "follow") the strobe synchronization timing pulses on the existing NAC wire run. This maintains the overall system flash timing of the additional strobes attaches to the FCPS.

When the FCPS-24FS8 is configured (via DIP switch settings) as a "sync follower," the FCPS' NAC outputs track the strobe synchronization pulses present at the FCPS' sync input terminal. The pulses originate from an upstream FACP or other power supply.

When the FCPS-24FS8 is configured (via DIP switch settings) as a "sync generator," the FCPS' sync input terminals are not used. Rather, the FCPS is the originator of the strobe synchronization pulses on the FCPS' NAC outputs. In "sync generator" mode, the sync type (System Sensor, Wheelock, or Gentex) is selectable via DIP switch settings.

Standards and Codes

The FCPS-24FS8 complies with the following standards:

- **NFPA 72** National Fire Alarm Code
- **UL 864** Standard for Control Units for Fire Alarm Systems (NAC expander mode)
- **UL 1481** Power Supplies for Fire Alarm Systems

Agency Listings and Approvals

These listings and approvals apply to the modules specified in this document. In some cases, certain modules or applications may not be listed by certain approval agencies, or listing may be in process. Consult factory for latest listing status.

- **UL Listed:** S2424
- **ULC Listed:** S2424
- **CSFM Approved:** 7315-0075:0206
- **MEA:** 219-02E
- **FM Approved**

Ordering Information

FCPS-24FS8: 8.0 A, 120 VAC remote charger power supply. Includes main printed circuit board, transformers, enclosure (15"H x 14.5"W x 2.75"D [cm: 38.1H x 36.83W x 6.985D]), and installation instructions

FCPS-24FS8C: Same as FCPS-24FS8, ULC-Listed

FCPS-24FS8E: 8.0 A, 240 VAC remote charger power supply. Includes main printed circuit board, transformers, enclosure (15"H x 14.5"W x 2.75"D [cm: 38.1H x 36.83W x 6.985D]), and installation instructions

ZNAC-4: Class A (Style Y) NAC option module

EOLR-1: 12/24 VDC end-of-line relay for monitoring four-wire smoke detector power

BAT-1270: Battery, 12-volt, 7.0 AH (two required)

PS-1270: Battery, 12-volt, 7.0 AH (two required)

90286: Optional module mounting kit, is required to install an addressable module on the power supply main circuit board

Fire•Lite® Alarms and System Sensor® are registered trademarks of Honeywell International, Inc. Wheelock® is a registered trademark of Cooper Technologies Company. Gentex® is a registered trademark of Gentex Corporation. ©2019 by Honeywell International Inc. All rights reserved. Unauthorized use of this document is strictly prohibited.



This document is not intended to be used for installation purposes.
We try to keep our product information up-to-date and accurate.
We cannot cover all specific applications or anticipate all requirements.
All specifications are subject to change without notice.

For more information, contact Fire•Lite Alarms. Phone: (800) 627-3473, FAX: (877) 699-4105.
www.firelite.com



Country of Origin: USA

ES-50X Battery Calculation

Secondary Power Source Requirements

Device	Standby Current (amps)				Secondary Alarm Current (amps)			
	Qty		Current Draw	Total	Qty		Current Draw	Total
Main Circuit Board	1	x	0.141000	= 0.141000	1	x	0.257000	= 0.257000
IPOTS-COM Communicator	0	x	0.040000	=	0	x	0.041000	=
4XTMF	0	x	0.005000	=	0	x	0.011000	=
EOLR-1	0	x	0.020000	=	0	x	0.020000	=
CELL-MOD-FL / CELL-CAB	0	x	0.055000	=	0	x	0.100000	=
ANN-BUS Devices								
ANN-SEC Card	0	x	0.003000	=	0	x	0.003000	=
ANN-80(-W)	0	x	0.015000	=	0	x	0.040000	=
ANN-100	0	x	0.020000	=	0	x	0.025000	=
ANN-(R)LED	0	x	0.028000	=	0	x	0.068000	=
ANN-RLY	0	x	0.015000	=	0	x	0.075000	=
ANN-I/O	0	x	0.035000	=	0	x	0.200000	=
ANN-I/O LED	0	x	0.000000	=	0	x	0.010000	=
ANN-S/PG	0	x	0.045000	=	0	x	0.045000	=
Addressable Devices								
BEAM355	0	x	0.002000	=				
BEAM355S	0	x	0.002000	=				
CP355	0	x	0.000300	=				
SD365CO	0	x	0.002000	=				
SD355CO	0	x	0.000300	=				
SD355	0	x	0.000300	=				
SD365	1	x	0.000200	= 0.000200				
SD355T	0	x	0.000300	=				
SD365T	0	x	0.000200	=				
H355	0	x	0.000300	=				
H365	0	x	0.000200	=				
H355HT	0	x	0.000300	=				
H365HT	0	x	0.000200	=				
H350R	0	x	0.000300	=				
H355R	0	x	0.000300	=				
H365R	0	x	0.000200	=				
D350RPL	0	x	0.000300	=				
D355PL	0	x	0.000300	=				
MMF-300	2	x	0.000375	= 0.000750				
MMF-300-10	0	x	0.003500	=				
MDF-300	0	x	0.000750	=				
MMF-301	0	x	0.000350	=				
MMF-302	0	x	0.000270	=				
MMF-302-6	0	x	0.002000	=				
BG-12LX	3	x	0.000375	= 0.001125				
CMF-300	0	x	0.000390	=				
CMF-300-6	0	x	0.002250	=				
CRF-300	0	x	0.000255	=				
CRF-300-6	0	x	0.001450	=				
CDRM-300	0	x	0.001300	=				
I300	0	x	0.000400	=				

ISO-6	0	x	0.002700	=						
B501BH-2	0	x	0.001000	=						
B501BHT-2	0	x	0.001000	=						
B224RB	0	x	0.000500	=						
B224BI	0	x	0.000450	=						
W-GATE	0	x	0.024000	=						
Maximum alarm draw for all Addressable devices ----->									0.20000	
Resettable Power										
4-Wire Smoke Detectors	0	x	0.000000	=		0	x	0.000000	=	
SWIFT Wireless										
W-GATE	0	x	0.040000	=		0	x	0.040000	=	
Auxiliary Power										
CMF-300 (Aux. Power)	0	x	0.001700	=		0	x	0.007000	=	
CMF-300-6 (Aux. Power)	0	x	0.008000	=		0	x	0.020000	=	
MMF-302 (Aux. Power)	0	x	0.012000	=		0	x	0.090000	=	
MMF-302-6 (Aux. Power)	0	x	0.050000	=		0	x	0.270000	=	
B200SR (Aux. Power)	0	x	0.000500	=		0	x	0.035000	=	
B200SR-LF (Aux. Power)	0	x	0.001000	=		0	x	0.125000	=	
Miscellaneous Devices										
FCPS-24FS8 NAC POWER	2	x	0.065000	=	0.130000	2	x	0.065000	=	0.130000
	0	x	0.000000	=		0	x	0.000000	=	
	0	x	0.000000	=		0	x	0.000000	=	
	0	x	0.000000	=		0	x	0.000000	=	
	0	x	0.000000	=		0	x	0.000000	=	
Output Circuits										
NAC/Output #1			0.000000	=				0.000000	=	
NAC/Output #2			0.000000	=				0.000000	=	
FCPS (remote Sync)	0	x	0.000000	=		0	x	0.021700	=	
Total Standby Load					0.273075	Total Alarm Load				0.587000

		ES-50X Battery Calculation			
Calculation in Total Sheet					
		Required Standby Time in Hours			
		24 Hours			
Total Standby Current	0.2731 Amps	x	24	=	6.554 AH
		Required Alarm Time in Minutes			
		5 Minutes			
Total Alarm Load	0.5870 Amps	x	0.084	=	0.049 AH
Total Current Load					6.603 AH
Multiply by the Derating Factor			1.2	=	x 1.20
Total Ampere Hours Required					7.92 AH

Jobsite Information: Fairway Pointe Bldg 10 Unit Bldg 17 Gallery Dr.

FCPS-24FS6 / 8 Battery Calculation

Entries only to be made in the Yellow cell locations

Regulated Load in Standby

Device Type	Number of Devices		Current (Amps)		Total Current (Amps)
Main PC Board	1	X	0.065	=	0.065
Power Supervision Relays		X	0.025	=	0
Auxiliary Current Draw from TB4 Terminals 9 & 10		X		=	0
STANDBY LOAD =					0.065

Regulated Load in ALARM

Device Type	Number of Devices		Current (Amps)		Total Current (Amps)
Main PC Board without AC	1	X	0.145	=	0.145
Power Supervision Relays		X	0.025	=	0
Auxiliary Current Draw from TB4 Terminals 9 & 10		X		=	0
NAC / Output # 1	8	X	0.122	=	0.976
NAC / Output # 2	9	X	0.14	=	1.26
NAC / Output # 3	7	X	0.155	=	1.085
NAC / Output # 4		X		=	0
ALARM LOAD =					3.466

Battery Amp Hour Calculation

Standby Load Current (Amps)	0.065	X	Required Standby Time (Typically 24 or 60 Hours)	24	=	1.56 AH
Alarm Load Current (Amps)	3.466	X	Required Alarm Time (Typically 5 or 10 Minutes)	10	=	0.58 AH
Sub Total Standby / Alarm Amp Hours						2.14 AH
Multiply by the Derating Factor					X	1.2 *
Total Ampere Hours Required =						3 AH

* Derating Factor required to compensate for the non-linear discharge characteristic of a battery.

- **Universal full event sole & dual path cellular &/or IP commercial fire alarm reporting from any panel brand, virtually anywhere nationwide**
- **Code-compliant, replaces 2 POTs lines per FACP** saves thousands of dollars per year over the leased landlines
- **Supports 12V-24V control panels and FACPs** that communicate using Contact ID and 4/2 (such as on legacy panels), as primary or backup
- **Full data Reporting to any Central Station nationwide, via choice of LTE Networks, Verizon® or AT&T®.** Communicate critical life and safety alarm reports on LTE (Long Term Evolution) 10+ year life, cyber-protected multi-billion dollar cellular network, for maximum life safety & liability protection.
- **Proven to work even where other's won't - using Signal Boost™ & twin dual diversity antennas** - Max. signal acquisition & null avoidance (receives signals simultaneously on both antennas)
- **Easiest installation, powered by panel, NO extra power supply, NO extra conduit.** (Excludes Direct AC-Powered "-PS" models, with transformer option.) †
- **Dual Path Cellular/IP Models Save Time & Money** - Uniquely including 4 programmable EOLR zone inputs; 2 Form C Relay outputs (no extra supervision modules to buy or install); plus, 2 Telephone-style jacks for easy FACP-connection. Self-supervised on 4 wires.
- **Preactivated to ensure communications** - saves time and labor onsite
- **LED Status /Trouble Indicators** 3 Radio Status LED Indicators (visible from outside standard model housing) - Green, Signal Strength; Amber- Busy/Activation; Red-Trouble (4 additional LEDs, not visible, for network status & troubleshooting). Power LED indicator viewable on outer metal enclosure models.
- **Over-the-Air Upgradable Communicator Firmware.** Remote ability for critical/mandatory updates, without a truck-roll
- **Cost-saving models and plans for any code requirement.** Dramatic savings over monthly dedicated landline charges.



Code-compliant standard or metal models on choice of Verizon or AT&T LTE networks.

UL and NFPA 72 Fire Code-Compliant, the StarLink Series Wireless Commercial Fire Alarm Sole Path & Dual Path Communicators provide universal support for any brand 12V to 24V fire alarm control panel, reporting in Contact ID and 4/2. With broadest LTE coverage footprint, Verizon or AT&T, using proven StarLink circuitry, they are also available in locking metal models. All provide the most economical solution for easy, versatile installation. Also regional compliances, i.e., CSFM, NYCFD, LAFD and more.

Easy, Universal Installation at Every Application; Panel-Powered Technology™. StarLink Fire Communications are easily connected to any panel or Fire Alarm Control Panel (FACP) standardly operating between 12V and 24V. Flexible in any application, StarLink Fire also comes in standard, or models in metal housings, with code-compliant supervision, and choice of power options, Panel-Powered Technology™ (powered by the panel), or direct-connect 120VAC models. **Signal Boost circuitry & dual diversity antennae** for maximum signal acquisition & null avoidance, receiving signals simultaneously on both antennae.

Flexible Performance & Reporting Options. StarLink Fire provides full data reporting, in sole and dual path, as a primary or backup, to any central station of your choice, without requiring any special equipment on premises. Ultra-affordable plans are available to meet various codes and requirements, with supervisory check-ins from 200 seconds, to 5 minutes; and/or from 1 to 6 hours. The units are very easily activated, plans and options are selected, and 24/7 account management is provided all through www.napcocomnet.com.

Napco StarLink Universal Fire Alarm Communicators

- **Sole Path Cellular and Dual Path Cellular &/or IP Models**
- **Choice of LTE Networks**, Verizon or AT&T models
- **Choice of plans** (varies by model) - check-ins from 200 seconds to 5-minutes, and from 1 hour; up to 6 hours for dual path
- **Patented Signal Boost™ and Dual Diversity Antennae** for maximum signal acquisition & null avoidance, receiving signals simultaneously on both antennae
- **Money-saving Tradeup incentive credit** for security professionals, on new or retrofit fire systems, i.e., tradeup missing/retired POTs lines, old radios & networks or new installations
- **Bonus: Full High-Speed Napco Panel remote uploading/downloading**
- **COMPLIANCES:** NFPA 72 Editions: 2019, 2016, 2013, 2010, 2007; UL 864, 10th Ed., UL1610, UL985, UL1023, NYCFD; CSFM; LAFD



Model Ordering & Specifications



	LTE Network	Cell	IP	WiFi Option**	Unique Onboard Labor/Cost-Saver Features	Electrical Input Ratings	Inputs	Input Ratings	Outputs	Output Ratings	Other Power Supply (option)†
STANDARD MODELS (ABS) 5.38 x 7.88 x 1.88" (HWD)											
SOLE PATH											
SLE-LTEA-FIRE	AT&T	Yes	No	No		Panel-Powered Tech'y:†† Input Voltage/Input Current: 10V = 90mA; 12-25V = 71mA, 200mA peak during transmissions	IN1, IN2, IN3	IN1: 9-25VDC Max input current 2mA IN2, IN3: 9-25VDC Max input current 1.2mA	PGM1, PGM2, PGM3	Open Collector Outputs Max 3V when active, Max 25V when not active. Max current 24mA@ 25V	
SLE-LTEV-FIRE	Verizon	Yes	No	No							
DUAL PATH											
SLE-LTEAI-FIRE	AT&T	Yes	Yes	Yes	2 TelCo jacks for EZ FACP Connect; 4 Programmable EOLR zone inputs; 2 Form C Relay outputs (avoids reqt for supervision module)	Panel-Powered Tech'y:†† Input Voltage: 10-25VDC; Input Current: 162mA to 100mA standby; 300mA peak during transmissions	IN1, IN2, IN3, IN4, IN5	IN1: 9-25VDC Max input current 2mA IN2, IN3, IN4, IN5: 9-25VDC Max input current 1.2mA	OUT1, OUT2, PGM3	OUT1, OUT2: Dry Contact, Form C Relay, 30V AC/DC, 500mA Max PGM3: Open Collector Outputs Max 3V when active, Max 25V when active. Max current 24mA@ 25V	
SLE-LTEVI-FIRE	Verizon	Yes	Yes	Yes							
MODELS IN METAL ENCLOSURE 9.63 x 11.75 x 3.38" (HWD)											
SOLE PATH											
SLE-LTEA-CFB	AT&T	Yes	No	No		Panel-Powered Tech'y:†† Input Voltage/Input Current: 10V = 90mA; 12-25V = 71mA, 200mA peak during transmissions	IN1, IN2, IN3	IN1: 9-25VDC Max input current 2mA IN2, IN3: 9-25VDC Max input current 1.2mA	PGM1, PGM2, PGM3	Open Collector Outputs Max 3V when active, Max 25V when not active. Max current 24mA@ 25V	
SLE-LTEV-CFB	Verizon	Yes	No	No							
SLE-LTEA-CFB-PS	AT&T	Yes	No	No		Direct AC-Powered: Input Voltage: 120VAC nominal Input Current: 150mA max; maximum charging current: 200mA	IN1, IN2, IN3	IN1: 9-25VDC Max input current 2mA IN2, IN3: 9-25VDC Max input current 1.2mA	PGM1, PGM2, PGM3	Open Collector Outputs Max 3V when active, Max 25V when not active. Maximum current 24mA@ 25V	Transformer (TRF12 16VAC, 20VA transformer)
SLE-LTEV-CFB-PS	Verizon	Yes	No	No							
DUAL PATH											
SLE-LTEAI-CFB	AT&T	Yes	Yes	Yes	2 TelCo jacks for EZ FACP Connect; 4 Programmable EOLR zone inputs; 2 Form C Relay outputs (avoids reqt for supervision module)	Panel-Powered Tech'y:†† Input Voltage: 10-25VDC; Input Current: 162mA to 100mA standby; 300mA peak during transmissions	IN1, IN2, IN3, IN4, IN5	IN1: 9-25VDC Max input current 2mA IN2, IN3, IN4, IN5: 9-25VDC Max input current 1.2mA	OUT1, OUT2, PGM3	OUT1, OUT2: Dry Contact, Form C Relay, 30V AC/DC, 500mA Max PGM3: Open Collector Outputs Max 3V when active, Max 25V when active. Max current 24mA@ 25V	
SLE-LTEVI-CFB	Verizon	Yes	Yes	Yes							
SLE-LTEAI-CFBPS	AT&T	Yes	Yes	Yes	2 TelCo jacks for EZ FACP Connect; 4 Programmable EOLR zone inputs; 2 Form C Relay outputs (avoids reqt for supervision module)	Direct AC-Powered: Input Voltage: 120VAC nominal Input Current: 200mA max; maximum charging current: 200mA	IN1, IN2, IN3, IN4, IN5	IN1: 9-25VDC Max input current 2mA IN2, IN3, IN4, IN5: 9-25VDC Max input current 1.2mA	OUT1, OUT2, PGM3	OUT1, OUT2: Dry Contact, Form C Relay, 30V AC/DC, 500mA Max PGM3: Open Collector Outputs Max 3V when active, Max 25V when active. Max current 24mA@ 25V	Transformer (TRF12 16VAC, 20VA transformer)
SLE-LTEVI-CFBPS	Verizon	Yes	Yes	Yes							

ACCESSORIES:

SLE-WIFI-MODULE Optionally connects supported dual path models to Internet via WiFi, eliminating Ethernet cable connection. Requires 7AH batt'y. (**See details WI2191)

SLE-ANEXT75 Optional extended range omni. antenna w/ 75' cable, premium low-loss cable & full mounting hardware & ground fault isolation mounting plate

SLE-ANEXT50 As above, with 50' cable

SLE-ANEXT30 As above, with 30' cable

TRF12 Optional Plug in AC Transformer, 16.5V / 20VA (use is subject to local code compliance)†

Free Commercial Fire LTE Tradeup Trifold Brochures / Mailers/Stuffers (A747)



FireLink™ Integrated Fire Alarm Control Panel w/ StarLink Fire LTE Built In

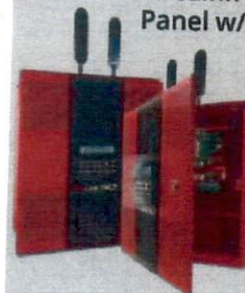

FL-32FACP-LTEV Firewolf 8 Zone 24V Conventional Commercial Fire Alarm Control Panel with onboard StarLink Fire® Sole Path, Verizon LTE Cellular Alarm Communicator and integral menu-driven LCD annunciator, w/ 4amp, 24V power supply. Optionally expandable up to 32 points/zones via commercial addressable, wireless or conventional fire devices (2 onboard NACs providing up to 4A notification power). Locking, metal red enclosure, (surface or flush mount) removable 16"x17" door w/14.25"x16" base. Houses 16Ah battery backup.



Indoor Selectable-Output Horns, Strobes, and Horn Strobes for Wall Applications

System Sensor L-Series audible visible notification products are rich with features guaranteed to cut installation times and maximize profits with lower current draw and modern aesthetics.

Features

- Updated Modern Aesthetics
- Small profile devices for Horns and Horn Strobes
- Plug-in design with minimal intrusion into the back box
- Tamper-resistant construction
- Automatic selection of 12- or 24-volt operation at 15 and 30 candela
- Field-selectable candela settings on wall units: 15, 30, 75, 95, 110, 135, and 185
- Horn rated at 88+ dBA at 16 volts
- Rotary switch for horn tone and two volume selections
- Mounting plate for all standard and all compact wall units
- Mounting plate shorting spring checks wiring continuity before device installation
- Electrically compatible with legacy SpectrAlert and SpectrAlert Advance devices
- Compatible with MDL3 sync module
- Strobes and Horn Strobes listed for wall mounting only
- Horns listed for wall or ceiling use

Agency Listings



S5512
S4011



FM approved except
for ALERT models
3057383, 3057072



7125-1653.0504
7135-1653.0503



The System Sensor L-Series offers the most versatile and easy-to-use line of horns, strobes, and horn strobes in the industry with lower current draws and modern aesthetics. With white and red plastic housings, standard and compact devices, and plain, FIRE, and FUEGO-printed devices, System Sensor L-Series can meet virtually any application requirement.

The L-Series line of wall-mount horns, strobes, and horn strobes include a variety of features that increase their application versatility while simplifying installation. All devices feature plug-in designs with minimal intrusion into the back box, making installations fast and foolproof while virtually eliminating costly and time-consuming ground faults.

To further simplify installation and protect devices from construction damage, the L-Series utilizes a universal mounting plate for all models with an onboard shorting spring, so installers can test wiring continuity before the device is installed.

Installers can also easily adapt devices to suit a wide range of application requirements using field-selectable candela settings, automatic selection of 12- or 24-volt operation, and a rotary switch for horn tones with two volume selections.

L-Series Specifications

Architect/Engineer Specifications

General

L-Series standard horns, strobes, and horn strobes shall mount to a standard 2 x 4 x 1⁷/₈-inch back box, 4 x 4 x 1¹/₂-inch back box, 4-inch octagon back box, or double-gang back box. L-Series compact products shall mount to a single-gang 2 x 4 x 1⁷/₈-inch back box. A universal mounting plate shall be used for mounting ceiling and wall products for all standard models and a separate universal mounting plate shall be used for mounting wall compact models. The notification appliance circuit wiring shall terminate at the universal mounting plate. Also, L-Series products, when used with the Sync•Circuit™ Module accessory, shall be powered from a non-coded notification appliance circuit output and shall operate on a nominal 12 or 24 volts. When used with the Sync•Circuit Module, 12-volt-rated notification appliance circuit outputs shall operate between 8.5 and 17.5 volts; 24-volt-rated notification appliance circuit outputs shall operate between 16.5 and 33 volts. Indoor L-Series products shall operate between 32 and 120 degrees Fahrenheit from a regulated DC or full-wave rectified unfiltered power supply. Strobes and horn strobes shall have field-selectable candela settings including 15, 30, 75, 95, 110, 135, and 185.

Strobe

The strobe shall be a System Sensor L-Series Model _____ listed to UL 1971 and shall be approved for fire protective service. The strobe shall be wired as a primary-signaling notification appliance and comply with the Americans with Disabilities Act requirements for visible signaling appliances, flashing at 1 Hz over the strobe's entire operating voltage range. The strobe light shall consist of a xenon flash tube and associated lens/reflector system.

Horn Strobe Combination

The horn strobe shall be a System Sensor L-Series Model _____ listed to UL 1971 and UL 464 and shall be approved for fire protective service. The horn strobe shall be wired as a primary-signaling notification appliance and comply with the Americans with Disabilities Act requirements for visible signaling appliances, flashing at 1 Hz over the strobe's entire operating voltage range. The strobe light shall consist of a xenon flash tube and associated lens/reflector system. The horn shall have two audibility options and an option to switch between a temporal three pattern and a non-temporal (continuous) pattern. These options are set by a multiple position switch. The horn on horn strobe models shall operate on a coded or non-coded power supply.

Synchronization Module

The module shall be a System Sensor Sync•Circuit model MDL3 listed to UL 464 and shall be approved for fire protective service. The module shall synchronize Strobes at 1 Hz and horns at temporal three. Also, while operating the strobes, the module shall silence the horns on horn strobe models over a single pair of wires. The module shall mount to a 4¹/₁₆ x 4¹/₁₆ x 2¹/₈-inch back box. The module shall also control two Style Y (class B) circuits or one Style Z (class A) circuit. The module shall synchronize multiple zones. Daisy chaining two or more synchronization modules together will synchronize all the zones they control. The module shall not operate on a coded power supply.

Physical/Electrical Specifications

Standard Operating Temperature	32°F to 120°F (0°C to 49°C)
Humidity Range	10 to 93% non-condensing
Strobe Flash Rate	1 flash per second
Nominal Voltage	Regulated 12 DC or regulated 24 DC/FWR ¹
Operating Voltage Range²	8 to 17.5 V (12 V nominal) or 16 to 33 V (24 V nominal)
Operating Voltage Range MDL3 Sync Module	8.5 to 17.5 V (12 V nominal) or 16.5 to 33 V (24 V nominal)
Input Terminal Wire Gauge	12 to 18 AWG
Wall-Mount Dimensions (including lens)	5.6" L x 4.7" W x 1.91" D (143 mm L x 119 mm W x 49 mm D)
Compact Wall-Mount Dimensions (including lens)	5.26" L x 3.46" W x 1.91" D (133 mm L x 88 mm W x 49 mm D)
Horn Dimensions	5.6" L x 4.7" W x 1.25" D (143 mm L x 119 mm W x 32 mm D)
Compact Horn Dimensions	5.25" L x 3.45" W x 1.25" D (133 mm L x 88 mm W x 32 mm D)

1. Full Wave Rectified (FWR) voltage is a non-regulated, time-varying power source that is used on some power supply and panel outputs.
2. Strobe products will operate at 12 V nominal only for 15 cd and 30 cd.

UL Current Draw Data

UL Max. Strobe Current Draw (mA RMS)				
Candela	Candela	8–17.5 Volts		16–33 Volts
		DC	DC	FWR
Candela Range	15	88	43	60
	30	143	63	83
	75	N/A	107	136
	95	N/A	121	155
	110	N/A	148	179
	135	N/A	172	209
	185	N/A	222	257

UL Max. Horn Current Draw (mA RMS)					
Sound Pattern	dB	8–17.5 Volts			16–33 Volts
		DC	DC	FWR	
Temporal	High	39	44	54	
Temporal	Low	28	32	54	
Non-Temporal	High	43	47	54	
Non-Temporal	Low	29	32	54	
3.1 KHz Temporal	High	39	41	54	
3.1 KHz Temporal	Low	29	32	54	
3.1 KHz Non-Temporal	High	42	43	54	
3.1 KHz Non-Temporal	Low	28	29	54	
Coded	High	43	47	54	
3.1 KHz Coded	High	42	43	54	

UL Max. Current Draw (mA RMS), Wall Horn Strobe, Candela Range (15–185 cd)									
DC Input	8–17.5 Volts			16–33 Volts					
	15cd	30cd	15cd	30cd	75cd	95cd	110cd	135cd	185cd
Temporal High	98	158	54	74	121	142	162	196	245
Temporal Low	93	154	44	65	111	133	157	184	235
Non-Temporal High	106	166	73	94	139	160	182	211	262
Non-Temporal Low	93	156	51	71	119	139	162	190	239
3.1K Temporal High	93	156	53	73	119	140	164	190	242
3.1K Temporal Low	91	154	45	66	112	133	160	185	235
3.1K Non-Temporal High	99	162	69	90	135	157	175	208	261
3.1K Non-Temporal Low	93	156	52	72	119	138	162	192	242

FWR Input	16–33 Volts							
	15cd	30cd	75cd	95cd	110cd	135cd	185cd	
Temporal High	83	107	156	177	198	234	287	
Temporal Low	68	91	145	165	185	223	271	
Non-Temporal High	111	135	185	207	230	264	316	
Non-Temporal Low	79	104	157	175	197	235	283	
3.1K Temporal High	81	105	155	177	196	234	284	
3.1K Temporal Low	68	90	145	166	186	222	276	
3.1K Non-Temporal High	104	131	177	204	230	264	326	
3.1K Non-Temporal Low	77	102	156	177	199	234	291	

Horn Tones and Sound Output Data

Horn and Horn Strobe Output (dBA)					
Switch Position	Sound Pattern	dB	8–17.5 Volts		16–33 Volts
			DC	DC	FWR
1	Temporal	High	84	89	89
2	Temporal	Low	75	83	83
3	Non-Temporal	High	85	90	90
4	Non-Temporal	Low	76	84	84
5	3.1 KHz Temporal	High	83	88	88
6	3.1 KHz Temporal	Low	76	82	82
7	3.1 KHz Non-Temporal	High	84	89	89
8	3.1 KHz Non-Temporal	Low	77	83	83
9*	Coded	High	85	90	90
10*	3.1 KHz Coded	High	84	89	89

* Settings 9 and 10 are not available on 2-wire horn strobes. Temporal coding must be provided by the NAC. If the NAC voltage is held constant, the horn output remains constantly on.

L-Series Dimensions

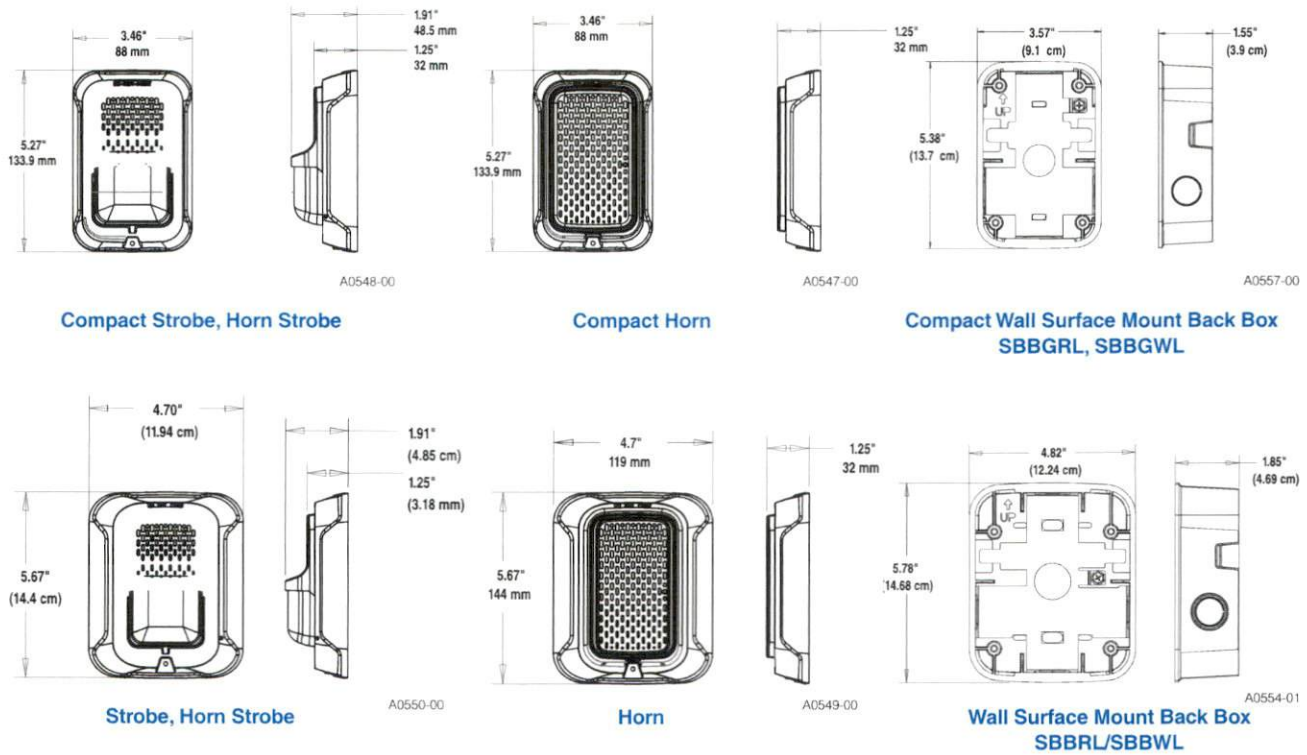

L-Series Ordering Information

Model	Description
Wall Horn Strobes	
P2RL	2-Wire, Horn Strobe, Red
P2WL	2-Wire, Horn Strobe, White
P2GRL	2-Wire, Compact Horn Strobe, Red
P2GWL	2-Wire, Comp 2 fil act Horn Strobe, White
P2RL-P	2-Wire, Horn Strobe, Red, Plain
P2WL-P	2-Wire, Horn Strobe, White, Plain
P2RL-SP	2-Wire, Horn Strobe, Red, FUEGO
P2WL-SP	2-Wire, Horn Strobe, White, FUEGO
P4RL	4-Wire, Horn Strobe, Red
P4WL	4-Wire, Horn Strobe, White
Wall Strobes	
SRL	Strobe, Red
SWL	Strobe, White
SGRL	Compact Strobe, Red
SGWL	Compact Strobe, White
SRL-P	Strobe, Red, Plain
SWL-P	Strobe, White, Plain
SRL-SP	Strobe, Red, FUEGO
SWL-CLR-ALERT	Strobe, White, ALERT

Model	Description
Horns*	
HRL*	Horn, Red
HWL*	Horn, White
HGRL*	Compact Horn, Red
HGWL*	Compact Horn, White
Accessories	
TR-2	Universal Wall Trim Ring Red
TR-2W	Universal Wall Trim Ring White
SBBRL	Wall Surface Mount Back Box, Red
SBBWL	Wall Surface Mount Back Box, White
SBBGRL	Compact Wall Surface Mount Back Box, Red
SBBGWL	Compact Wall Surface Mount Back Box, White

Notes:

All -P models have a plain housing (no "FIRE" marking on cover).
 All -SP models have "FUEGO" marking on cover.
 All -ALERT models have "ALERT" marking on cover.
 *Horn-only models are listed for wall or ceiling use.



3825 Ohio Avenue • St. Charles, IL 60174
 Phone: 800-SENSOR2 • Fax: 630-377-6495
 www.systemsensor.com

©2018 System Sensor
 Product specifications subject to change without notice. Visit systemsensor.com
 for current product information, including the latest version of this data sheet.
 AVDS865-05 • 2/22/2018



Indoor Selectable-Output Low Frequency Sounders and Low Frequency Sounder Strobes

System Sensor L-Series audible visible notification products are rich with features guaranteed to maximize profits with lower current draw and modern aesthetics.



Features

- 520 Hz \pm 10% square wave tone, NFPA compliance
- Full candela range plus High/Low tone options to optimize current draw for a wide variety of applications
- Compact, standard, and round ceiling options
- Field-selectable candela settings. Wall units: 15, 30, 75, 95, 110, 135, and 185. Ceiling units: 15, 30, 75, 95, 115, 150, and 177
- Rotary switch for High/Low, Temp3, Temp4, and Continuous settings. Sounder-only models also offer a Coded setting.
- Plug-in design with minimal intrusion into the back box
- Mounting plate shorting spring checks wiring continuity before device installation
- Electrically compatible with legacy SpectrAlert and SpectrAlert Advance devices (Direct replacement for HW/R-LF and P2R/WH-LF)
- Compatible with MDL3 sync module
- Wall and ceiling mount options available
- Updated modern aesthetics

The L-Series offers the most versatile and easy-to-use line of low frequency sounder and low frequency sounder strobes in the industry. With white and red plastic housings, listed for wall and ceiling mounting, L-Series Low Frequency can meet virtually any application requirement.

The low frequency sounder and low frequency sounder strobes were designed to address the NFPA 72 sleeping space requirements that require a low frequency notification appliance that operates within frequency range of 520 Hz \pm 10% and is of a square wave tone. Like the entire L-Series product line they include a variety of features that increase their application versatility while simplifying installation. All devices feature plug-in designs with minimal intrusion into the back box, making installations fast and foolproof while virtually eliminating costly and time-consuming ground faults.

To further simplify installation and protect devices from construction damage, L-Series uses a universal mounting plate with an onboard shorting spring, so installers can test wiring continuity before the device is installed.

Installers can also easily adapt devices to a suit a wide range of application requirements using field-selectable candela settings, 24-volt operation, and a rotary switch for 520 Hz low frequency sounder tones.

Agency Listings



Horns only: 7135-1653.0516
Horn/Strobes: 7125-1653.0517

L-Series Specifications

Architect/Engineer Specifications

General

L-Series low frequency sounder and low frequency sounder strobes shall mount to a standard 4 x 4 x 1½-inch back box, 4-inch octagon back box, or double-gang back box. Two-wire products shall also mount to a single-gang 2 x 4 x 1⅞-inch back box. A universal mounting plate shall be used for mounting products. The notification appliance circuit wiring shall terminate at the universal mounting plate. Also, L-Series products, when used with the Sync•Circuit™ Module accessory, shall be powered from a non-coded notification appliance circuit output and shall operate on a nominal 12 or 24 volts. When used with the Sync•Circuit Module, 24-volt-rated notification appliance circuit outputs shall operate between 16.5 and 33 volts. Indoor L-Series products shall operate between 32 and 120 degrees Fahrenheit (0°C to 49°C) from a regulated DC or full-wave rectified unfiltered power supply. Low Frequency Sounder strobes shall have field-selectable candela settings. Wall units: 15, 30, 75, 95, 110, 135, and 185. Ceiling units: 15, 30, 75, 95, 115, 150, and 177. The field selectable tones will sound within the frequency range of 520 Hz ± 10% square wave tone and have a permanent marking on the housing that reads "520 Hz".

Low Frequency Sounder

The low frequency sounder shall be a System Sensor L-Series Model _____ listed to UL 464 and shall be approved for fire protective service. The low frequency sounder and the Sync•Circuit™ MDL3 Module accessory, if used, shall be powered from a notification appliance circuit output and shall operate on a nominal 24 volts (includes fire alarm panels with built-in sync). When used with the Sync•Circuit Module MDL3, 24-volt rated notification appliance circuit outputs shall operate between 16.5 to 33 volts. If the notification appliances are not UL 9th edition listed with the corresponding panel or power supply being used, then refer to the compatibility listing of the panel to determine maximum devices on a circuit. The low frequency sounder has an option to switch between temporal three or temporal four pattern, non-temporal (continuous) pattern and coded supply within the frequency range of 520 Hz ± 10% square wave tone. The low frequency sounder shall operate on a coded or non-coded power supply with high and low volume settings.

Low Frequency Sounder Strobe Combination

The low frequency sounder strobe shall be a System Sensor L-Series Model _____ listed to UL 1971 and UL 464 and shall be approved for fire protective service. The low frequency sounder strobe shall be wired as a primary-signaling notification appliance and comply with the Americans with Disabilities Act requirements for visible signaling appliances, flashing at 1 Hz over the strobe's entire operating voltage range. The strobe light shall consist of a xenon flash tube and associated lens/reflector system. The sounder shall have an option to switch between a temporal three or temporal four pattern and a non-temporal (continuous) pattern. These options are set by a multiple position switch. The low frequency sounder on low frequency sounder strobe models shall operate on a non-coded power supply with high and low volume settings. The field selectable tones will sound within the frequency range of 520 Hz ± 10% square wave tone.

Synchronization Module

The module shall be a System Sensor Sync•Circuit model MDL3 listed to UL 464 and shall be approved for fire protective service. The module shall synchronize SpectrAlert strobes at 1 Hz and low frequency sounder at temporal three. Also, while operating the strobes, the module shall silence the low frequency sounder on low frequency sounder strobe models over a single pair of wires. The module shall mount to a 4 11/16 x 4 11/16 x 2 1/8-inch back box. The module shall also control two Class B circuits or one Class A circuit. The module shall synchronize multiple zones. Daisy chaining two or more synchronization modules together will synchronize all the zones they control. The module shall not operate on a coded power supply.

Physical/Electrical Specifications

Standard Operating Temperature	32°F to 120°F (0°C to 49°C)
Humidity Range	10 to 93% non-condensing
Frequency Range	520 Hz ± 10%
Strobe Flash Rate	1 flash per second
Nominal Voltage Low Frequency Sounder	Regulated 24 DC/FWR ¹
Nominal Voltage Range Low Frequency Sounder Strobe	Regulated 24 VDC/FWR ¹
Operating Voltage Range	16 to 33 V (24 V nominal)
Operating Voltage Range MDL3 Sync Module	16.5 to 33 V (24 V nominal)
Input Terminal Wire Gauge	12 to 18 AWG

Dimensions

Wall Sounder Strobe (including lens)	5.6" L x 4.7" W x 1.9" D (142 mm L x 119 mm W x 49 mm D)
Ceiling Sounder Strobe (including lens)	6.8" diameter x 2.47" high (173mm diameter x 62.7 mm D)
Standard Wall Sounder	5.6" L x 4.7" W x 1.5" D (142 mm L x 119 mm W x 38 mm D)
Compact Wall Sounder	5.25" L x 3.46" W x 1.5" D (133mm L x 88mm W x 38mm D)
Ceiling Sounder	6.8" diameter x 1.4" high (173mm diameter x 36mm high)
Standard Wall Sounder with SBBRL/SBBWL Surface Mount Back Box	5.70" L x 4.8" W x 3.3" D (145 mm L x 120 mm W x 87 mm D)
Compact Wall Sounder with SBBGRL/SBBGWL Surface Mount Back Box	5.4" L x 3.6" W x 3.0" D (137 mm L x 91mm W x 76 mm D)
Low Frequency Ceiling Sounder with SBBCRL/SBBCWL Surface Mount Back Box	6.9" diameter x 3.9" high (175mm diameter x 99mm high)

Notes:

1. Full Wave Rectified (FWR) voltage is a non-regulated, time-varying power source that is used on some power supply and panel outputs.

UL Current Draw and Sound Output Data

Low Frequency Sounder Strobe Current Draw (mA) and Sound Output (dBA)

Wall Sounder Strobe	Volume Setting	Current Draw (mA)															Sound Output (dBA)
		16-33 VDC															
		16-33 VDC					16-33 FWR					16-33 V					
Pos Tone	DC	30cd	75cd	95cd	110cd	135cd	185cd	15cd	30cd	75cd	95cd	110cd	135cd	185cd	DC FWR		
1	Temporal 3	High	98	115	158	173	182	212	266	136	153	188	206	228	258	80	80
2	Temporal 3	Low	98	102	141	162	173	202	255	150	150	176	194	216	242	80	80
3	Temporal 4	High	98	108	137	151	178	202	252	200	198	169	188	212	242	80	80
4	Temporal 4	Low	102	104	122	136	163	187	237	176	174	154	173	197	227	76	76
5	Continuous	High	141	158	198	216	234	264	305	190	207	249	268	289	321	80	80
6	Continuous	Low	120	128	179	196	215	244	285	165	182	226	244	266	297	80	80

Ceiling Sounder Strobe

Ceiling Sounder Strobe	Volume Setting	Current Draw (mA)															Sound Output (dBA)
		16-33 VDC															
		16-33 VDC					16-33 FWR					16-33 V					
Pos Tone	DC	30cd	75cd	95cd	110cd	135cd	185cd	15cd	30cd	75cd	95cd	110cd	135cd	185cd	DC FWR		
1	Temporal 3	High	98	115	158	173	197	236	259	136	153	188	206	238	287	80	80
2	Temporal 3	Low	98	102	141	162	181	224	244	150	150	176	194	226	269	80	80
3	Temporal 4	High	98	108	145	161	186	224	249	200	198	169	189	222	269	80	80
4	Temporal 4	Low	102	104	122	136	170	208	227	176	174	154	173	206	252	76	76
5	Continuous	High	141	158	198	216	245	293	295	190	207	249	268	302	357	80	80
6	Continuous	Low	120	128	179	196	225	271	273	165	182	226	244	278	330	80	80

UL Max. Low Frequency Sounder Current Draw (mA RMS)

Wall and Ceiling Sounder	Volume Setting	Current Draw (mA)			Sound Output (dBA) Reverberant		
		16-33 Volts			16-33 Volts		
		DC	FWR	DC FWR	DC	FWR	DC FWR
1	Temporal 3	High	108	150	80	80	80
2	Temporal 3	Low	78	76	76	76	76
3	Temporal 4	High	111	151	80	80	80
4	Temporal 4	Low	80	76	76	76	76
5	Continuous	High	111	151	80	80	80
6	Continuous	Low	80	76	76	76	76
7	Coded	High	111	151	80	80	80
8	Coded	Low	80	76	76	76	76

*NOTE: For coded tones, temporal coding must be provided by the NAC. If the NAC voltage is held constant, the sounder output will remain constantly on. Coded ratings provided are for continuous voltage.

L-Series Dimensions

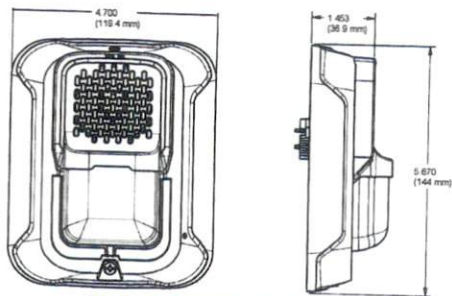

Wall LF Sounder Strobe

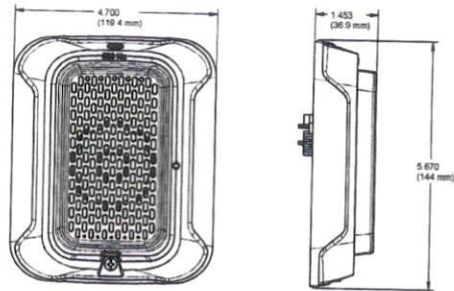

Wall LF Sounder

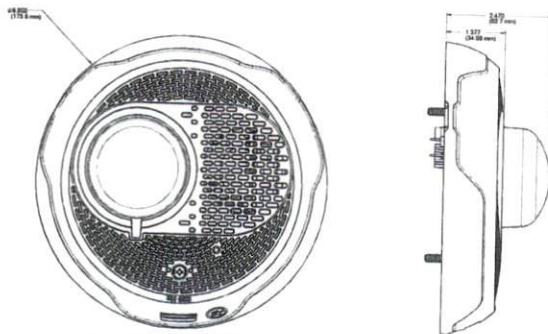

Ceiling/Wall LF Sounder Strobe

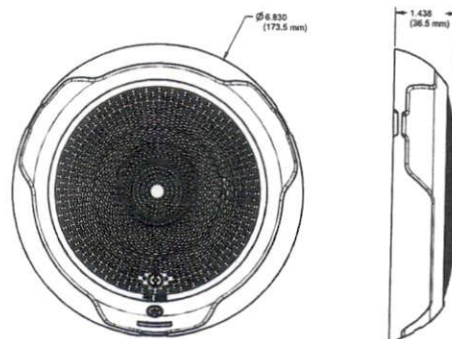

Ceiling/Wall LF Sounder

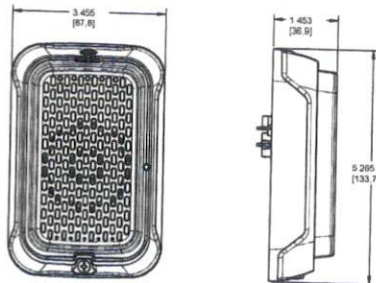

Compact Wall LF Sounder

Part No.		Description
Red	White	
Low Frequency Sounder Strobes		
P2RL-LF	P2WL-LF	LF Sounder Strobe, Wall
PC2RL-LF	PC2WL-LF	LF Sounder Strobe, Ceiling/Wall
Low Frequency Sounders		
HRL-LF	HWL-LF	LF Sounder, Wall
HGRL-LF	HGWL-LF	Compact LF Sounder, Wall
HCRL-LF	HCWL-LF	LF Sounder, Ceiling/Wall
Accessories		
MDL3R	MDL3W	Sync•Circuit™ Module, UL-listed
SBBRL	SBBWL	Surface Mount Back Box, Wall
SBBCRL	SBBCWL	Surface Mount Back Box, Ceiling
SBBGRL	SBBGWL	Surface Mount Back Box, Wall, Compact

System Sensor® is a registered trademark and Sync•Circuit™ is a trademark of Honeywell International, Inc.



3825 Ohio Avenue • St. Charles, IL 60174
Phone: 800-SENSOR2 • Fax: 630-377-6495

©2020 System Sensor.
Product specifications subject to change without notice. Visit systemsensor.com for current product information, including the latest version of this data sheet.
AVDS910-01 • 9/15/2020

BG-12LX

Addressable Manual Pull Station



Addressable Devices

General

The Fire-Lite BG-12LX is a state-of-the-art, dual-action (i.e., requires two motions to activate the station) pull station that includes an addressable interface (mounted inside) for Fire-Lite's addressable fire alarm control panels (FACPs). Because the BG-12LX is addressable, the control panel can display the exact location of the activated manual station. This leads fire personnel quickly to the location of the alarm.

Features

- Maintenance personnel can open station for inspection and address setting without causing an alarm condition.
- Built-in bicolor LED, which is visible through the handle of the station, flashes in normal operation and latches steady red when in alarm.
- Handle latches in down position and the word "ACTIVATED" appears to clearly indicate the station has been operated.
- Captive screw terminals wire-ready for easy connection to SLC loop (accepts up to 12 AWG/3.25 mm² wire).
- Can be surface mounted (with SB-10 or SB-I/O) or semi-flush mounted. Semi-flush mount to a standard single-gang, double-gang, or 4" (10.16 cm) square electrical box.
- Smooth dual-action design.
- Meets ADAAG controls and operating mechanisms guidelines (Section 4.1.3[13]); meets ADA requirement for 5 lb. maximum activation force.
- Highly visible.
- Attractive shape and textured finish.
- Key reset.
- Includes Braille text on station handle.
- Optional trim ring (BG12TR).
- Meets UL 38, Standard for Manually Actuated Signaling Boxes.

Construction

Shell, door, and handle are molded of durable polycarbonate material with a textured finish.

Specifications

- **Shipping Weight:** 9.6 oz. (272.15 g)
- **Normal operating voltage:** 24 VDC.
- **Maximum SLC loop voltage:** 28.0 VDC.
- **Maximum SLC standby current:** 375 μ A.
- **Maximum SLC alarm current:** 5 mA.
- **Temperature Range:** 32°F to 120°F (0°C to 49°C)
- **Relative Humidity:** 10% to 93% (noncondensing)
- **For use indoors in a dry location**

Installation

The BG-12LX will mount semi-flush into a single-gang, double-gang, or standard 4" (10.16 cm) square electrical outlet box, or will surface mount to the model SB-10 or SB-I/O surface backbox. If the BG-12LX is being semi-flush mounted, then the optional trim ring (BG12TR) may be used. The BG12TR is



FLPullStation.jpg

usually needed for semi-flush mounting with 4" (10.16 cm) or double-gang boxes (not with single-gang boxes).

Operation

Pushing in, then pulling down on the handle causes it to latch in the down/activated position. Once latched, the word "ACTIVATED" (in bright yellow) appears at the top of the handle, while a portion of the handle protrudes from the bottom of the station. To reset the station, simply unlock the station with the key and pull the door open. This action resets the handle; closing the door automatically resets the switch.

Each manual station, on command from the control panel, sends data to the panel representing the state of the manual switch. Two rotary decimal switches allow address settings (1 – 159 with Breakaway Tab removed for MS-9600 Series, 1 – 99 and MS-9200UDLS, 1 – 50 for MS-9050UD).

Architectural/Engineering Specifications

Manual Fire Alarm Stations shall be non-coded, with a key-operated reset lock in order that they may be tested, and so designed that after actual Emergency Operation, they cannot be restored to normal except by use of a key. An operated station shall automatically condition itself so as to be visually detected as activated. Manual stations shall be constructed of red-colored polycarbonate material with clearly visible operating instructions provided on the cover. The word FIRE shall appear on the front of the stations in white letters, 1.00 inches (2.54 cm) or larger. Stations shall be suitable for surface mounting on matching backbox SB-10 or SB-I/O; or semi-flush mounting on a standard single-gang, double-gang, or 4" (10.16 cm) square electrical box, and shall be installed

within the limits defined by the Americans with Disabilities Act (ADA) or per national/local requirements. Manual Stations shall be Underwriters Laboratories listed.

Manual stations shall connect with two wires to one of the control panel SLC loops. The manual station shall, on command from the control panel, send data to the panel representing the state of the manual switch. Manual stations shall provide address setting by use of rotary decimal switches.

Product Line Information

BG-12LX: Dual-action addressable pull station. Includes key locking feature. (Listed for Canadian and non-Canadian applications.)

SB-10: Surface backbox; metal.

SB-I/O: Surface backbox; plastic.

BG12TR: Optional trim ring.

17003: Keys, set of two.

Agency Listings and Approvals

In some cases, certain modules or applications may not be listed by certain approval agencies, or listing may be in process. Consult factory for latest listing status.

- **UL/ULC Listed:** S711 (listed for Canadian and non-Canadian applications).
- **MEA:** 67-02-E.
- **CSFM:** 7150-0075:0184.
- **FM Approved.**

Patented: U.S. Patent No. D428,351; 6,380,846; 6,314,772; 6,632,108.

FireLite® Alarms® is a registered trademark of Honeywell International Inc. ©2012 by Honeywell International Inc. All rights reserved. Unauthorized use of this document is strictly prohibited.



This document is not intended to be used for installation purposes.
We try to keep our product information up-to-date and accurate.
We cannot cover all specific applications or anticipate all requirements.
All specifications are subject to change without notice.



Made in the U.S. A.

For more information, contact Fire•Lite Alarms. Phone: (800) 627-3473, FAX: (877) 699-4105.
www.firelite.com

SD365 Series

Addressable Photoelectric Smoke Detectors

DF-61010:C

 **FIRE-LITE Alarms**
by Honeywell

Addressable Devices

The Fire•Lite® Alarms SD365(A), SD365R(A), and SD365HT(A) intelligent plug-in smoke detectors are designed for both performance and aesthetics, and are direct replacements for the SD355 Series. A new modern, sleek, contemporary design and enhanced optical sensing chamber is engineered to sense smoke produced by a wide range of combustion sources in accordance with more stringent code standards.

Exclusively for use with Fire•Lite's addressable fire alarm control panels, the SD365(A) Series point ID capability allows each detector's address to be set with rotary, decimal address switches, providing exact detector location for emergency personnel to quickly locate a fire during its early stages, potentially saving precious rescue time while also reducing property damage. Two LEDs on each sensor light to provide a local, visible sensor indication.

The SD365(A) Series also offers 135°F (57°C) fixed temperature thermal sensing on the SD365T(A) and a remote test capable detector on the SD365R(A) for use with DNR(A)/DNRW duct smoke detector housings.

Features

SLC LOOP:

- Two-wire SLC loop connection
- Unit uses base for wiring
- Compatible with LiteSpeed™ and CLIP protocol systems
- Stable communication technique with noise immunity

ADDRESSING:

- Addressable by device
- Rotary, decimal addressing
(Refer to the *Fire•Lite panel manuals* for device capacity.)

ARCHITECTURE:

- Sleek, low-profile, stylish design
- Unique single-source design to respond quickly and dependably to a broad range of fires
- Integral communications and built-in device-type identification
- Built-in tamper resistant feature
- Remote test feature from the panel
- Walk test with address display (an address on 121 will blink the detector LED: 12-[pause]-1 (*LiteSpeed systems only*))
- Built-in functional test switch activated by external magnet
- Removable cover and insect-resistant screen for simple field cleaning
- Expanded color options

OPERATION:

- Designed to meet UL 268 7th Edition
- Factory preset at 1.5% nominal sensitivity for panel alarm threshold level
- LED "blinks" when the unit is polled (communicating with the fire panel) and latches in alarm.
- Low standby current

MECHANICALS:

- Sealed against back pressure
- SEMS screws for wiring of the separate base
- Designed for direct-surface or electrical-box mounting



- Plugs into separate base for ease of installation and maintenance
- Separate base allows interchange of photoelectric, ionization and thermal sensors

OPTIONS:

- Optional relay, isolator, and sounder bases

Installation

SD365 Series plug-in intelligent smoke detectors use a detachable base to simplify installation, service and maintenance. Installation instructions are shipped with each detector.

Mount detector base (all base types) on an electrical backbox which is at least 1.5" (3.81 cm) deep. For a chart of compatible junction boxes, see *DF-60059*.

NOTE: Because of the inherent supervision provided by the SLC loop, end-of-line resistors are not required. Wiring "T-taps" or branches are permitted for Class "B" wiring only. When using relay or sounder bases, consult the *I300(A)* installation sheet *I56-3626* for device limitations between isolator modules and isolator bases.

Construction

These detectors are constructed of fire-resistant plastic. The SD365 Series plug-in intelligent smoke detectors are designed to commercial standards and offer an attractive appearance.

Operation

Each SD365 Series detector uses one of the panel's addresses (total limit is panel dependent) on the Fire•Lite Signaling Line Circuit (SLC). It responds to regular polls from the control panel and reports its type and the status. If it receives a test command from the panel (or a local magnet test), it stimulates its electronics and reports an alarm. It blinks its LEDs when polled and turns the LEDs on when commanded by the panel. The SD365 Series offers features and performance that represent the latest in smoke detector technology.

Detector Sensitivity Test

Each detector can have its sensitivity tested (required per NFPA 72, Chapter 14 on *Inspection, Testing and Maintenance*) when installed/connected to an Fire•Lite addressable fire alarm control panel. The results of the sensitivity test can be printed for record keeping.

Product Line Information

NOTE: "-IV" suffix indicates CLIP and LiteSpeed device.

NOTE: "A" suffix indicates Canadian version.

SD365: White, low-profile intelligent photoelectric sensor, LiteSpeed only

SD365A: Same as SD365 but with ULC listing

SD365-IV: Ivory, low-profile intelligent photoelectric sensor

SD365A-IV: Same as SD365-IV but with ULC listing

SD365T: White, same as **SD365** but includes a built-in 135°F (57°C) fixed-temperature thermal device, LiteSpeed only

SD365TA: Same as SD365T but with ULC listing

SD365T-IV: Ivory, same as SD365T but includes a built-in 135°F (57°C) fixed-temperature thermal device

SD365TA-IV: Same as SD365T-IV but with ULC listing

SD365R: White, low-profile intelligent photoelectric sensor, remote test capable, for use with DNR/DNRW, LiteSpeed only

SD365RA: Same as SD365R but with ULC listing, for use with DNRA

SD365R-IV: Ivory, low-profile intelligent photoelectric sensor, remote test capable, for use with DNR/DNRW

SD365RA-IV: Same as SD365R-IV but with ULC listing, for use with DNRA

INTELLIGENT BASES

NOTE: For details on intelligent bases, see DF-60059.

B300-6: White, 6" base, standard flanged low-profile mounting base (CSFM: 7300-1653:0109)

B300-6-IV: Ivory, 6" base, standard flanged low-profile mounting base (CSFM: 7300-1653:0109)

B300A-6: Same as B300-6, ULC listed

B300A-6-IV: Ivory, 6" standard flanged low-profile mounting base, ULC listed

B300-6-BP: Bulk pack of B300-6, package contains 10

B501-WHITE: White, 4" standard European flangeless mounting base. UL/ULC listed (CSFM: 7300-1653:0109)

B501-BL: Black, 4" standard European flangeless mounting base. UL/ULC listed (CSFM: 7300-1653:0109)

B501-IV: Ivory color, 4" standard European flangeless mounting base. UL/ULC listed (CSFM: 7300-1653:0109)

B501-WHITE-BP: Bulk pack of B501-WHITE contains 10

B224RB-WH: White, relay base (CSFM: 7300-1653:0216)

B224RB-IV: Ivory, relay base (CSFM: 7300-1653:0216)

B224RBA-WH: White, relay base, ULC listing

B224RBA-IV: Ivory, relay base, ULC listing

B224BI-WH: White, isolator detector base (CSFM: 7300-1653:0216)

B224BI-IV: Ivory isolator detector base (CSFM: 7300-1653:0216)

B224BIA-WH: White, isolator detector base, ULC listing

B224BIA-IV: Ivory isolator detector base, ULC listing

B200S-WH: White, Intelligent addressable sounder base capable of producing sound output in high or low volume with ANSI Temporal 3, ANSI Temporal 4, continuous tone, marching tone, and custom tone. Uses LiteSpeed protocol. (CSFM: 7300-1653:0213)

B200S-IV: Ivory, Intelligent addressable sounder base capable of producing sound output in high or low volume with ANSI Temporal 3, ANSI Temporal 4, continuous tone, marching tone, and custom tone. Uses LiteSpeed protocol. (CSFM: 7300-1653:0213)

B200SA-WH: Same as B200S-WH, ULC listing

B200SA-IV: Same as B200S-IV, ULC listing

B200SCOA-WH: White, Intelligent, programmable sounder base in English/French (required in Canada for ULC applications with CO Series detector applications)

B200SCOA-IV: Ivory Intelligent, programmable sounder base in English/French (required in Canada for ULC applications with CO Series detector applications, ULC listing)

B200S-LF-WH: White, Low Frequency Intelligent, programmable sounder base. Produces a fundamental frequency of 520 Hz +/- 10% with a square wave or its equivalent; designed to meet the NFPA 72 sleeping space requirement. (CSFM: 7300-1653:0238)

B200S-LF-IV: Ivory, Low Frequency Intelligent, programmable sounder base. Produces a fundamental frequency of 520 Hz +/- 10% with a square wave or its equivalent; designed to meet the NFPA 72 sleeping space requirement. (CSFM: 7300-1653:0238)

B200SR-WH: White, Intelligent sounder base capable of producing sound output with ANSI Temporal 3 or continuous tone. Intended for retrofit applications. (CSFM: 7300-1653:0213)

B200SR-IV: Ivory, Intelligent sounder base capable of producing sound output with ANSI Temporal 3 or continuous tone. Intended for retrofit applications. (CSFM: 7300-1653:0213)

B200SRA-WH: Same as B200SR-WH with, ULC listing

B200SRA-IV: Same as B200SR-IV in Ivory color, ULC listing

B200SR-LF-WH: White, Low Frequency Intelligent, programmable sounder base. Produces a fundamental frequency of 520 Hz +/- 10% with a square wave or its equivalent; designed to meet the NFPA 72 sleeping space requirement. Intended for retrofit applications. (CSFM: 7300-1653:0238)

B200SR-LF-IV: Ivory, Low Frequency Intelligent, programmable sounder base. Produces a fundamental frequency of 520 Hz +/- 10% with a square wave or its equivalent; designed to meet the NFPA 72 sleeping space requirement. Intended for retrofit applications. (CSFM: 7300-1653:0238)

MOUNTING KITS AND ACCESSORIES

TR300: White, replacement flange for B210LP(A) base

TR300-IV: Ivory, replacement flange for B210LP(A) base

RA100Z(A): Remote LED annunciator. 3-32 VDC. Mounts to a U.S. single-gang electrical box. For use with B501(A) and B300-6(A).

M02-04-00: Test magnet

M02-09-00: Test magnet with telescoping handle

CK300: Color Kit (includes cover and trim ring), white, 10-pack

CK300-IV: Color Kit (includes cover and trim ring), ivory, 10-pack

CK300-BL: Color Kit (includes cover and trim ring), black, 10-pack

SYSTEM SPECIFICATIONS

Sensitivity:

- UL Applications: 0.5% to 4.0% per foot obscuration.
- ULC Applications: 0.5% to 3.5% per foot obscuration

Size: 2.0" (51mm) high; base determines diameter

- **B300-6:** 6.1" (15.6 cm) diameter
- **B501:** 4" (10.2 cm) diameter

For a complete list of detector bases see DF-60983

Shipping weight: 3.4 oz. (95 g)

Operating temperature range:

- SD365: 32°F to 122°F (0°C to 50°C)
- SD365T Series: 32°F to 100°F (0°C to 38°C)
- SD365R Series installed in a DNR/DNRW, -4°F to 158°F (-20°C to 70°C)

UL/ULC Listed Velocity Range: 0-4000 ft/min. (1219.2 m/min.), suitable for installation in ducts

Relative humidity: 10% – 93% non-condensing

Thermal ratings: fixed-temperature set point 135°F (57°C), rate-of-rise detection 15°F (8.3°C) per minute, high temperature heat 190°F (88°C)

ELECTRICAL SPECIFICATIONS

Voltage range: 15 - 32 volts DC peak

Standby current (max. avg.): 200µA @ 24 VDC (once communication every 5 seconds with LED enabled)

Max current: 4.5 mA @ 24 VDC ("ON")

DETECTOR SPACING AND APPLICATIONS

Fire•Lite recommends spacing detectors in compliance with NFPA 72. In low airflow applications with smooth ceiling, space detectors 30 feet (9.1m). For specific information regarding detector spacing, placement, and special applications refer to NFPA 72. A *System Smoke Detector Application Guide*, document SPAG91, is available at www.systemsensor.com.

Listings and Approvals

Listings and approvals below apply to the SD365 Series detectors. In some cases, certain modules may not be listed by certain approval agencies, or listing may be in process. Consult factory for latest listing status.

- UL/ULC Listing: S1059
- FM Approved
- CSFM: 7272-0075:0502

LiteSpeed™ is a trademark, and Fire•Lite® Alarms and System Sensor® are registered trademarks of Honeywell International Inc. ©2020 by Honeywell International Inc. All rights reserved. Unauthorized use of this document is strictly prohibited.



This document is not intended to be used for installation purposes.
We try to keep our product information up-to-date and accurate.
We cannot cover all specific applications or anticipate all requirements.
All specifications are subject to change without notice.

For more information, contact Fire•Lite Alarms. Phone: (800) 627-3473, FAX:(877) 699-4105.
www.firelite.com

Country of Origin: Mexico

MMF-300(A) Series, MDF-300

Addressable Monitor Modules



Addressable Devices

General

Four different monitor modules are available for Fire-Lite's intelligent control panels to suit a variety of applications. Monitor modules are used to supervise a circuit of dry-contact input devices, such as conventional heat detectors and pull stations, or monitor and power a circuit of two-wire smoke detectors (MMF-302(A)).

MMF-300(A) is a standard-sized module (typically mounts to a 4" [10.16 cm] square box) that supervises either a Style D (Class A) or Style B (Class B) circuit of dry-contact input devices.

MMF-301(A) is a miniature monitor module a mere 1.3" (3.302 cm) H x 2.75" (6.985 cm) W x 0.65" (1.651 cm) D that supervises a Style B (Class B) circuit of dry-contact input devices. Its compact design allows the MMF-301(A) to be mounted in a single-gang box behind the device it monitors.

MMF-302(A) is a standard-sized module used to monitor and supervise compatible two-wire, 24 volt, smoke detectors on a Style D (Class A) or Style B (Class B) circuit.

MDF-300(A) is a standard-sized dual monitor module used to monitor and supervise two independent two-wire Style B (Class B) dry-contact initiating device circuits (IDCs) at two separate, consecutive addresses in intelligent, two-wire systems.

LiteSpeed™ is a communication protocol developed by Fire-Lite Engineering that greatly increases the speed of communication between analog intelligent devices. Intelligent devices communicate in a grouped fashion. If one of the devices within the group has new information, the panel CPU stops the group poll and concentrates on single points. The net effect is response speed greater than five times that of other communication protocols.

MMF-300(A) Monitor Module

- Built-in type identification automatically identifies this device as a monitor module to the control panel.
- Powered directly by two-wire SLC loop. No additional power required.
- High noise (EMF/RFI) immunity.
- SEMS screws with clamping plates for ease of wiring.
- Direct-dial entry of address: 01 – 159 on MS-9600 series panels, 01 – 99 on other compatible systems.
- LED flashes during normal operation and latches on steady to indicate alarm.

The MMF-300(A) Monitor Module is intended for use in intelligent, two-wire systems, where the individual address of each module is selected using the built-in rotary switches. It provides either a two-wire or four-wire fault-tolerant Initiating Device Circuit (IDC) for normally-open-contact fire alarm and supervisory devices. The module has a panel-controlled LED indicator. The MMF-300(A) can be used to replace M300(A) modules in existing systems.

MMF-300(A) APPLICATIONS

Use to monitor a zone of four-wire smoke detectors, manual fire alarm pull stations, waterflow devices, or other normally-open dry-contact alarm activation devices. May also be used to monitor normally-open supervisory devices with special

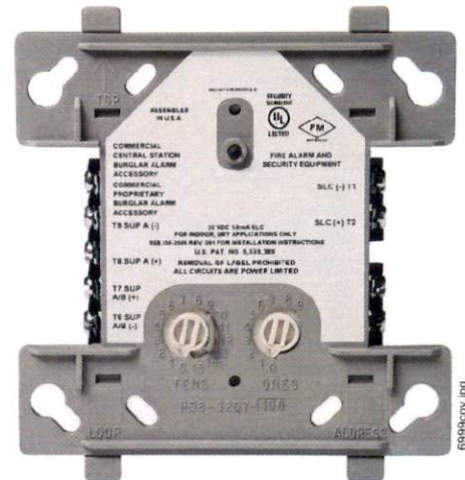

MMF-300(A) (Type H)

supervisory indication at the control panel. Monitored circuit may be wired as an NFPA Style B (Class B) or Style D (Class A) Initiating Device Circuit. A 47K Ohm End-of-Line Resistor (provided) terminates the Style B circuit. No resistor is required for supervision of the Style D circuit.

MMF-300(A) OPERATION

Each MMF-300(A) uses one of the available module addresses on an SLC loop. It responds to regular polls from the control panel and reports its type and the status (open/normal/short) of its Initiating Device Circuit (IDC). A flashing LED indicates that the module is in communication with the control panel. The LED latches steady on alarm (subject to current limitations on the loop).

MMF-300(A) SPECIFICATIONS

Nominal operating voltage: 15 to 32 VDC.

Maximum current draw: 5.0 mA (LED on).

Average operating current: 375 μ A (LED flashing), 1 communication every 5 seconds, 47k EOL.

Maximum IDC wiring resistance: 1500 Ohms.

Maximum IDC Voltage: 11 Volts.

EOL resistance: 47K Ohms.

Temperature range: 32°F to 120°F (0°C to 49°C).

Humidity range: 10% to 93% noncondensing.

Dimensions: 4.5" (11.43 cm) high x 4" (10.16 cm) wide x 1.25" (3.175 cm) deep. Mounts to a 4" (10.16 cm) square x 2.125" (5.398 cm) deep box.

MMF-301(A) Mini Monitor Module

- Built-in type identification automatically identifies this device as a monitor module to the panel.
- Powered directly by two-wire SLC loop. No additional power required.
- High noise (EMF/RFI) immunity.

- Tinned, stripped leads for ease of wiring.
- Direct-dial entry of address: 01 – 159 on MS-9600 series panels, 01 – 99 on other compatible systems

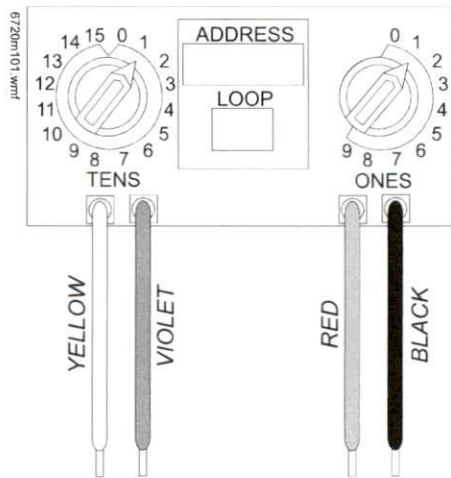

The MMF-301(A) Mini Monitor Module can be installed in a single-gang junction directly behind the monitored unit. Its small size and light weight allow it to be installed without rigid mounting. The MMF-301(A) is intended for use in intelligent, two-wire systems where the individual address of each module is selected using rotary switches. It provides a two-wire initiating device circuit for normally-open-contact fire alarm devices. The MMF-301(A) can be used to replace M301(A) modules in existing systems.

MMF-301(A) APPLICATIONS

Use to monitor a single device or a zone of four-wire smoke detectors, manual fire alarm pull stations, waterflow devices, or other normally-open dry-contact devices. May also be used to monitor normally-open supervisory devices with special supervisory indication at the control panel. Monitored circuit/device is wired as an NFPA Style B (Class B) Initiating Device Circuit. A 47K Ohm End-of-Line Resistor (provided) terminates the circuit.

MMF-301(A) OPERATION

Each MMF-301(A) uses one of the available module addresses on an SLC loop. It responds to regular polls from the control panel and reports its type and the status (open/normal/short) of its Initiating Device Circuit (IDC).

MMF-301(A) SPECIFICATIONS

Nominal operating voltage: 15 to 32 VDC.

Average operating current: 350 μ A, 1 communication every 5 seconds, 47k EOL; 600 μ A Max. (Communicating, IDC Shorted).

Maximum IDC wiring resistance: 1500 Ohms.

Maximum IDC Voltage: 11 Volts.

Maximum IDC Current: 450 μ A.

EOL resistance: 47K Ohms.

Temperature range: 32°F to 120°F (0°C to 49°C).

Humidity range: 10% to 93% noncondensing.

Dimensions: 1.3" (3.302 cm) high x 2.75" (6.985 cm) wide x 0.65" (1.651 cm) deep.

Wire length: 6" (15.24 cm) minimum.

MMF-302(A) Interface Module

- Supports compatible two-wire smoke detectors.

- Supervises IDC wiring and connection of external power source.
- High noise (EMF/RFI) immunity.
- SEMS screws with clamping plates for ease of wiring.
- Direct-dial entry of address: 01 – 159 on MS-9600 series panels, 01 – 99 on other compatible systems.
- LED flashes during normal operation.
- LED latches steady to indicate alarm on command from control panel.

The MMF-302(A) Interface Module is intended for use in intelligent, addressable systems, where the individual address of each module is selected using built-in rotary switches. This module allows intelligent panels to interface and monitor two-wire conventional smoke detectors. It transmits the status (normal, open, or alarm) of one full zone of conventional detectors back to the control panel. All two-wire detectors being monitored must be UL compatible with the module. The MMF-302(A) can be used to replace M302(A) modules in existing systems.

MMF-302(A) APPLICATIONS

Use the MMF-302(A) to monitor a zone of two-wire smoke detectors. The monitored circuit may be wired as an NFPA Style B (Class B) or Style D (Class A) Initiating Device Circuit. A 3.9 K Ohm End-of-Line Resistor (provided) terminates the end of the Style B or D (class B or A) circuit (maximum IDC loop resistance is 25 Ohms). Install ELR across terminals 8 and 9 for Style D application.

MMF-302(A) OPERATION

Each MMF-302(A) uses one of the available module addresses on an SLC loop. It responds to regular polls from the control panel and reports its type and the status (open/normal/short) of its Initiating Device Circuit (IDC). A flashing LED indicates that the module is in communication with the control panel. The LED latches steady on alarm (subject to current limitations on the loop).

MMF-302(A) SPECIFICATIONS

Nominal operating voltage: 15 to 32 VDC.

Maximum current draw: 5.1 mA (LED on).

Maximum IDC wiring resistance: 25 Ohms.

Average operating current: 270 μ A, 1 communication and 1 LED flash every 5 seconds, 3.9k eol.

EOL resistance: 3.9K Ohms.

External supply voltage (between Terminals T10 and T11):

- DC voltage: 24 volts power limited.
- Ripple voltage: 0.1 Vrms maximum.
- Current: 90 mA per module maximum.

Temperature range: 32°F to 120°F (0°C to 49°C).

Humidity range: 10% to 93% noncondensing.

Dimensions: 4.5" (11.43 cm) high x 4" (10.16 cm) wide x 1.25" (3.175 cm) deep. Mounts to a 4" (10.16 cm) square x 2.125" (5.398 cm) deep box.

MDF-300(A) Dual Monitor Module

The MDF-300(A) Dual Monitor Module is intended for use in intelligent, two-wire systems. It provides two independent two-wire initiating device circuits (IDCs) at two separate, consecutive addresses. It is capable of monitoring normally open contact fire alarm and supervisory devices. The module has a single panel-controlled LED.

NOTE: The MDF-300(A) provides two Style B (Class B) IDC circuits ONLY. Style D (Class A) IDC circuits are NOT supported in any application.

MDF-300(A) SPECIFICATIONS

Normal operating voltage range: 15 to 32 VDC.

Maximum current draw: 6.4 mA (LED on).

Average operating current: 750 μ A (LED flashing).

Maximum IDC wiring resistance: 1,500 Ohms.

Maximum IDC Voltage: 11 Volts.

Maximum IDC Current: 240 μ A

EOL resistance: 47K Ohms.

Temperature range: 32° to 120°F (0° to 49°C).

Humidity range: 10% to 93% (non-condensing).

Dimensions: 4.5" (11.43 cm) high x 4" (10.16 cm) wide x 1.25" (3.175 cm) deep. Mounts to a 4" (10.16 cm) square x 2.125" (5.398 cm) deep box.

MDF-300(A) AUTOMATIC ADDRESSING

The MDF-300(A) automatically assigns itself to two addressable points, starting with the original address. For example, if the MDF-300(A) is set to address "26", then it will automatically assign itself to addresses "26" and "27".

NOTE: "Ones" addresses on the MDF-300(A) are 0, 2, 4, 6, or 8 only. Terminals 6 and 7 use the first address, and terminals 8 and 9 use the second address.

CAUTION:

Avoid duplicating addresses on the system.

MDF-300(A): Monitor module, dual, two independent Class B circuits.

SMB500: Optional surface-mount backbox.

NOTE: See installation instructions and refer to the SLC Wiring Manual, PN 51309.

Architects'/Engineers' Specifications

Specifications of these devices and all FireLite products are available from FireLite.

Installation

MMF-300(A), MMF-302(A), and MDF-300(A) modules mount directly to a standard 4" (10.16 cm) square, 2.125" (5.398 cm) deep, electrical box. They may also be mounted to the SMB500 surface-mount box. Mounting hardware and installation instructions are provided with each module. All wiring must conform to applicable local codes, ordinances, and regulations. These modules are intended for power-limited wiring only.

The MMF-301(A) module is intended to be wired and mounted without rigid connections inside a standard electrical box. All wiring must conform to applicable local codes, ordinances, and regulations.

Agency Listings and Approvals

In some cases, certain modules may not be listed by certain approval agencies, or listing may be in process. Consult factory for latest listing status.

- **UL:** S2424.
- **ULC:** S2424.
- **FM Approved.**
- **CSFM:** 7300-0075:0185.
- **MEA:** 72-01-E.

Product Line Information

NOTE: "A" suffix indicates ULC-listed model.

MMF-300(A): Monitor module.

MMF-301(A): Monitor module, miniature.

MMF-302(A): Monitor module, two-wire detectors.