

Notifier Early Warning Fire Alarm System

Submittal Data For:

Tree of Knowledge Daycare Center

622 Buffalo Lake Road

Sanford, NC 27332

FireWarden-100-2(E) Rev 3

Intelligent Addressable FACP



Addressable Fire Alarm Control Panel

General

The Notifier FireWarden-100-2 Rev 3 (NFW2-100) with Version 5.0 firmware is a combination FACP (Fire Alarm Control Panel) and DACT (Digital Alarm Communicator/Transmitter) all on one circuit board. This compact intelligent addressable control panel has an extensive list of powerful features.

The SLC (Signaling Line Circuit) of the FireWarden-100-2 Rev 3 operates using a Rapid Group Polling communication protocol technology that polls multiple devices simultaneously for a quicker device response time. This patented technology allows a fully-loaded panel with up to 198 devices to report an incident and activate the notification circuits in under 10 seconds. With this improved polling, devices can be wired on standard twisted, unshielded wire up to a distance of 10,000 feet.

The 's quick-remove chassis protects the electronics during construction. The backbox can be installed allowing field wiring to be pulled. When construction is completed, the electronics can be quickly installed with just two bolts.

New features for Rev 3 with Version 5.0 firmware include removable terminal blocks, improved transient protection, additional secondary ANN-BUS, and increased power for the resettable and remote sync outputs.

Available accessories include ANN-BUS devices as well as ACS LED, graphic and LCD annunciators, and reverse polarity/city box transmitter.

The integral DACT transmits system status (alarms, supervisorys, troubles, AC loss, etc.) to a Central Station via the public switched telephone network. It also allows remote and local programming of the control panel using the PS-Tools Upload/Download utility. In addition, the control panel may be programmed or interrogated off-site via the public switched telephone network. Any personal computer with Windows® XP or greater, a compatible modem, and PS-Tools—the Upload/Download software kit—may serve as a Service Terminal. This allows download of the entire program or upload of the entire program, history file, walktest data, current status and system voltages. The panel can also be programmed through the FACP's keypad or via a standard PS-2 computer keyboard, which can be plugged directly into the printed circuit board. This permits easy typing of address labels and other programming information.

Version 5.0 firmware supports the following: Primary and Secondary ANN-bus devices, NP-A100, USB port, NAC circuit diagnostics, a new report has been added to the walk-test that lists untested devices, new device types added: audio telephone type code for NFV-25/50ZST, Photo Supervisory and auto-resettable Drill (non-latching).

The FireWatch Series internet monitoring modules IPDACT-2 and IPDACT-2UD permit monitoring of alarm signals over the Internet saving the monthly cost of two dedicated business telephone lines. Although not required, the secondary telephone line may be retained providing backup communication over the public switched telephone line.

NOTE: Unless otherwise specified, the term "FireWarden-100-2" is used in this document to refer to both the FireWarden-100-2 and the FireWarden-100-2E FACP's (Fire Alarm Control Panels). Likewise, "NFW2-100" refers to NFW2-100E as well.

Features

- Listed to UL standard 864, 9th edition.
- On-board DACT.

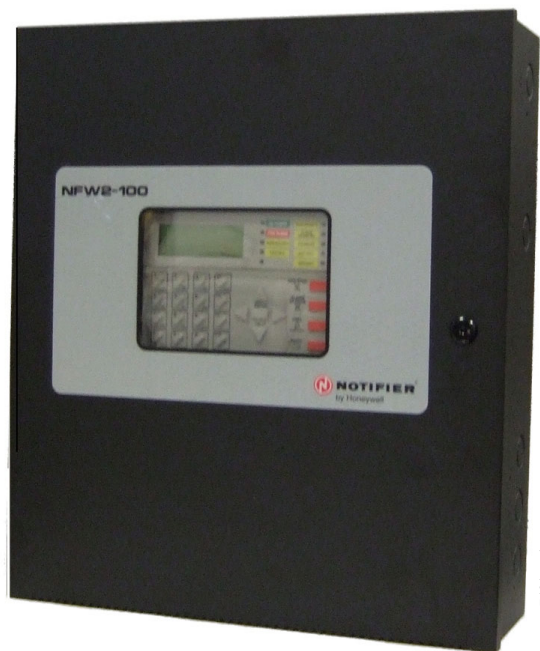

- Remote site or local USB port upload/download, using PS-Tools.
- Four (4) Style Y (Class B) NAC circuits, which can be converted to four (4) Style Z (Class A) circuits with optional ZNAC-92 converter module. (Up to 6.0 amps total NAC power when using optional XRM-24B.)
- Selectable strobe synchronization for System Sensor, Wheelock, and Gentex devices.
- Remote Acknowledge, Silence, Reset and Drill via addressable monitor modules or FDU-80, N-ANN-80 or Legacy ACS Annunciators.
- ANN-BUS for connection to following optional modules (cannot be used if ACS annunciators are used):
 - N-ANN-80(-W) Remote LCD Annunciator
 - N-ANN-I/O LED Driver
 - N-ANN-S/PG Printer Module
 - N-ANN-RLY Relay Module
 - N-ANN-LED Annunciator Module
 - N-ANN-RLED Annunciator Module alarms only
 - ROME Relay Option Module Enclosure
- ACS & Terminal-mode Annunciators:
 - ACS Annunciators: Up to 32 Legacy ACM Series annunciators (ACM-16AT or ACM-32 series). Cannot be used if ANN-BUS devices are used.
 - Terminal-mode Annunciators: Up to 32 Legacy FDU-80 annunciators.
- EIA-232 printer/PC interface (variable baud rate) on main circuit board, for use with optional UL-listed printer PRN-6.
- Integral 80-character LCD display with backlighting.
- Real-time clock/calendar with automatic daylight savings control.
- Detector sensitivity test capability (NFPA 72 compliant).

- History file with 1,000-event capacity.
- Maintenance alert warns when smoke detector dust accumulation is excessive.
- Automatic device type-code verification.
- One person audible or silent walk test with walk-test log and printout.
- Point trouble identification.
- Waterflow (nonsilenceable) selection per monitor point.
- System alarm verification selection per detector point.
- PAS (Positive Alarm Sequence) and presignal delay per point (NFPA 72 compliant).

NOTE: Only detectors may participate in PAS.

SLC LOOP:

- SLC can be configured for NFPA Style 4, 6, or 7 operation.
- SLC supports up to 198 addressable devices per loop (99 detectors and 99 monitor, control, or relay modules).
- SLC loop maximum length 10,000 ft. (3,000 m.).
See installation manual for wire tables.

NOTIFICATION APPLIANCE CIRCUITS (NACS):

- Four onboard NACs with additional NAC capability using output control modules (NC-100). The four Class B NACs can be converted to four Class A NACs with optional ZNAC-92 converter module.
- Silence Inhibit and Auto Silence timer options.
- Continuous, March Time, Temporal or California code for main circuit board NACs with two-stage capability.
- Selectable strobe synchronization per NAC.
- 2.5 amps maximum per each NAC circuit.

NOTE: Maximum 24VDC system power output is shared among all NAC circuits and 24VDC special-application auxiliary power outputs. Total available output is 3.0 amps. Using the optional XRM-24B transformer increases 24VDC output to 6.0 amps.

PROGRAMMING AND SOFTWARE:

- Autoprogram (learn mode) reduces installation time.
- Custom English labels (per point) may be manually entered or selected from an internal library file.
- Three Form-C relay outputs (two programmable).
- 99 software zones.
- Continuous fire protection during online programming at the front panel.
- Program Check automatically catches common errors not linked to any zone or input point.
- **OFFLINE PROGRAMMING:** Create the entire program in your office using a Windows®-based software package (NFW2-100 requires PS-Tools Programming software, available on www.magni-fire.com). Upload/download system programming locally to the NFW2-100 Rev 3 in less than one minute.
- USB upload/download programming with standard Male-A to Male-B cable.

User Interface

LED INDICATORS

- AC Power (green)
- Fire Alarm (red)
- Supervisory (yellow)
- Alarm Silenced (yellow)
- System Trouble (yellow)
- Maintenance/Presignal (yellow)
- Disabled (yellow)
- Battery Fault (yellow)

- Ground Fault (yellow)

KEYPAD CONTROLS

- Acknowledge/Step
- Alarm Silence
- Drill
- System Reset (lamp test)
- 16-key alpha-numeric pad (similar to telephone keypad)
- 4 cursor keys
- Enter

Product Line Information

NFW2-100: FireWarden-100-2 Rev 3 198-point addressable Fire Alarm Control Panel, one SLC loop. Includes 80-character LCD display, single printed circuit board mounted on chassis, and cabinet. 120 VAC operation.

NFW2-100R: Same as **NFW2-100**, except in a red backbox.

NFW2-100E: Same as **NFW2-100**, except with 240 VAC operation.

4XTM Reverse Polarity Transmitter Module: Provides supervised output for local energy municipal box transmitter, alarm, and trouble.

ZNAC-92: Optional converter module which converts four (4) Style Y (Class B) NAC circuits to four (4) Style Z (Class A) circuits.

PS Tools: Programming software for Windows®-based PC computer (cable not included), available on www.firelite.com.

DP-9692B: Optional dress panel for FireWarden-100-2 Rev 3.

TR-CE-B: Optional trim Ring for semi-flush mounting.

BB-26: Battery backbox, holds up to two 26 AH batteries and CHG-75.

NFS-LBB: Battery box, houses two 55 AH batteries.

CHG-75: Battery charger for lead-acid batteries with a rating of 25 to 75 AH.

CHG-120: Remote battery charging system for lead-acid batteries with a rating of 55 to 120 AH. Requires additional NFS-LBB for mounting.

NOTE: CHG-120 or CHG-75 required for batteries larger than 18AH.

BAT Series: Batteries, see data sheet DN-6933.

XRM-24B(E): Optional transformer. Increases system power output to 6.0 amps. Use XRM-24BE with FireWarden-100-2E Rev 3.

PRT/PK-CABLE: Cable printer/personal computer interface cable; required for printer or for local upload/download programming and updating panel firmware.

PRN-6: UL listed compatible event printer. Uses tractor-fed paper.

IPDACT-2/2UD, IPDACT Internet Monitoring Module: Mounts in bottom of enclosure with optional mounting kit (PN IPBRKT). Connects to primary and secondary DACT telephone output ports for internet communications over customer provided ethernet internet connection. Requires compatible Teldat VisorALARM Central Station Receiver. Can use DHCP or static IP. (*See data sheet DN-60408 for more information.*)

IPBRKT: Mounting kit for IPDACT-2/2UD in common enclosure.

IPSPLT: Y-adaptor option allows connection of both panel dialer outputs to one IPDACT-2/2UD cable input.

COMPATIBLE ANNUNCIATORS

N-ANN-80(-W): LCD Annunciator is a remote LCD annunciator that mimics the information displayed on the FACP LCD display. Recommended wire type is un-shielded. (Basic model is black; order -W version for white; see DN-7114.)

N-ANN-LED: Annunciator Module provides three LEDs for each zone: Alarm, Trouble and Supervisory. Ships with red or black enclosure (see DN-60242).

N-ANN-RLED: Provides alarm (red) indicators for up to 30 input zones or addressable points. (See DN-60242).

N-ANN-RLY: Relay Module, which can be mounted inside the cabinet, provides 10 programmable Form-C relays. (See DN-7107.)

ROME-B: Relay Option Module Enclosure (order ROME-B for black or ROME for red). Provides one **N-ANN-RLY** Relay Module already installed. The ROME Series provides mounting space for one additional Relay Module or one addressable Multi-module. (See *Installation Sheet PN 53530*.)

N-ANN-S/PG: Serial/Parallel Printer Gateway module provides a connection for a serial or parallel printer. (See DN-7103.)

N-ANN-I/O: LED Driver Module provides connections to a user supplied graphic annunciator. (See DN-7105.)

ACM-8R: Relay module provides 8 Form-C 5.0 amp relays.

ACM Annunciator Series: LED-type fire annunciators capable of providing up to 99 software zones of annunciation. Available in increments of 16 or 32 points to meet a variety of applications.

LDM Graphic Series: Lamp Driver Module series for use with custom graphic annunciators.

FDU-80 (Liquid Crystal Display) point annunciator: 80-character, backlit LCD-type fire annunciators capable of displaying English-language text.

NOTE: For more information on Compatible Annunciators for use with the FireWarden-100-2 Rev 3, see the following data sheets (document numbers) *ACM-8R (DN-3558)*, *ACS/ACM Series (DN-0524)*, *LDM Series (DN-0551)*, *FDU-80 (DN-6820)*.

COMPATIBLE ADDRESSABLE DEVICES

All feature a polling LED and rotary switches for addressing.

NI-100: Addressable low-profile ionization smoke detector.

NP-100: Addressable low-profile photoelectric smoke detector.

NP-100T: Addressable low-profile photoelectric smoke detector with thermal sensor.

NP-100R: Addressable remote test capable detector for use with DNR(W) duct smoke detector housings.

NH-100: Fast-response, low-profile heat detector.

NH-100R: Fast-response, low-profile heat detector with rate-of-rise option.

NH-100H: Fixed high-temperature detector that activates at 190F/88C.

NP-A100: Addressable low-profile multi-sensor detector.

DNR: Innovair Flex low-flow non-relay duct-detector housing. Order NP-100R separately.

DNRW: Innovair Flex low-flow non-relay duct-detector housing, with NEMA-4 rating. Watertight. (Order NP-100R separately.)

NMM-100: Addressable Monitor Module for one zone of normally-open dry-contact initiating devices. Mounts in standard 4.0" (10.16 cm.) box. Includes plastic cover plate and end-of-line resistor. Module may be configured for either a Style B (Class B) or Style D (Class A) IDC.

NDM-100: Dual Monitor Module. Same as NMM-100 except it provides two Style B (Class B) only IDCs.

NMM-100P: Miniature version of NMM-100. Excludes LED and Style D option. Connects with wire pigtailed. May mount in device backbox.

NZM-100: Similar to NMM-100, but may monitor up to 20 conventional two-wire detectors. Requires resettable 24 VDC power. Consult factory for compatible smoke detectors.

NC-100: Addressable Control Module for one Style Y/Z (Class B/A) zone of supervised polarized Notification Appliances. Mounts directly to a 4.0" (10.16 cm.) electrical box. Notification

Appliance Circuit option requires external 24 VDC to power notification appliances.

NC-100R: Addressable relay module containing two isolated sets of Form-C contacts, which operate as a DPDT switch. Mounts directly to a 4.0" (10.16 cm.) box, surface mount using the SMB500.

NOT-BG12LX: Addressable manual pull station with interface module mounted inside.

N100-ISO: Fault Isolator Module. This module isolates the SLC loop from short circuit conditions (required for Style 6 or 7 operation).

SMB500: Used to mount all modules except the NMM-100P.

NMM-100-10: Ten-input monitor module. Mount one or two modules in a BB-XP cabinet (optional). Mount up to six modules on a CHS-6 chassis in a BB-25.

NZM-100-6: Six-zone interface module for compatible conventional two-wire detectors. Mount one or two modules in a BB-XP cabinet (optional). Mount up to six modules on a CHS-6 chassis in a BB-25.

NOTE: For more information on Compatible Addressable Devices for use with the FireWarden-100-2 Rev 3, see the following data sheets (document numbers): *N100-ISO (DN-6994)*, *NP-100 series (DN-6995)*, *NI-100 (DN-6996)*, *NH-100 series (DN-6997)*, *ND-100 series (DN-7006)*, *NP-A100 (DN-6998)*, *NMM-100/NMM-100P/NDM-100/NZM-100 (DN-6999)*, *NC-100/NC-100R (DN-7000)*, *NOT-BG12LX (DN-7001)*, *NMM-100-10 (DN-6990)*, and *NZM-100-6 (DN-60150)*.

Wiring Requirements

While shielded wire is not required, it is recommended that all SLC wiring be twisted-pair to minimize the effects of electrical interference. Wire size should be no smaller than 18 AWG (0.78 mm²) and no larger than 12 AWG (3.1 mm²). The wire size depends on the length of the SLC circuit. Refer to the panel manual for wiring details.

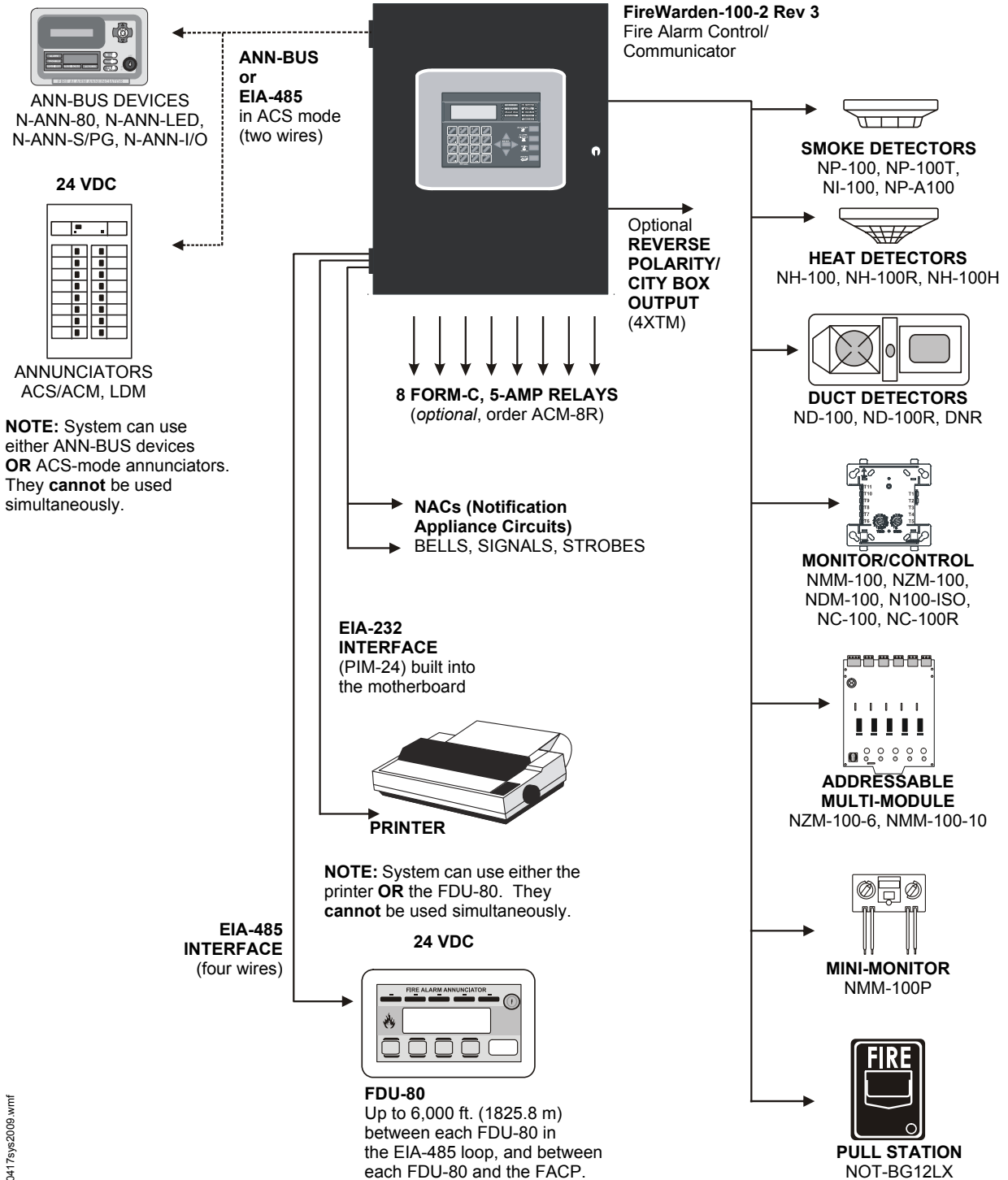

60417sys2009.wmf

SYSTEM SPECIFICATIONS

System Capacity

- Intelligent Signalling Line Circuits..... 1
- Addressable device capacity 198
- Programmable software zones 99
- ACS Annunciators 32
- ANN-bus devices 16

Electrical Specifications

AC Power: FireWarden-100-2 Rev 3: 120 VAC, 60 Hz, 3.0 amps. FireWarden-100-2 Rev 3(E): 240 VAC, 50 Hz, 1.5 amps. Wire size: minimum 14 AWG (2.00 mm²) with 600 V insulation.

Battery charger capacity: 7 AH - 18 AH batteries. Up to two 18 Ah batteries can be housed in the FACP cabinet. Larger batteries require an external battery charger such as the CHG-75 or CHG-120, and a separate battery cabinet such as the BB-26 or NFS-LBB.

Communication Loop: Supervised and power-limited.

Notification Appliance Circuits: Each terminal block provides connections for two Style Y (Class B) for a total of four Style Y (Class B) or with an optional ZNAC-92 module converts to four Style Z (Class A) NACs. Maximum signaling current per circuit: 2.5 amps. End-of-Line Resistor: 4.7K ohm, 1/2 watt (P/N 71252 UL listed) for Style Y (Class B) NAC. Refer to panel documentation and *Notifier Device Compatibility Document* for listed compatible devices.

Two Programmable Relays and One Fixed Trouble Relay: Contact rating: 2.0 amps @ 30 VDC (resistive), 0.5 amps @ 30 VAC (resistive). Form-C relays.

Special Application Non-resettable Power (24 VDC Nominal): Jumper selectable (JP4) for conversion to resettable power output. Up to 1.0 amp total DC current available from each output. Power-limited.

Special Application Resettable Power (24 VDC nominal): Jumper selectable (JP6) for conversion to non-resettable power. Up to 1.0 amp total DC current available. Refer to the *Notifier Device Compatibility Document* for listed compatible devices.

Remote Sync Output: Remote power supply synchronization output. Nominal special application power: 24 VDC. Maximum current: 300 mA. End-of-Line Resistor: 4.7K ohm. Output linked to NAC 1 control. Supervised and power-limited.

Telephone Interface: Unless used with Teldat VISORALARM, requires dedicated business telephone number with a minimum of 5 volts DC (off-hook voltage). Obtain dedicated phone line directly from your local phone company. Do not use shared phone lines or PBX (digital) type phone line extensions.

Cabinet Specifications

Door: 19.26" (48.92 cm.) high x 16.82" (42.73 cm.) wide x 0.12" (.30 cm.) deep. **Backbox:** 19.00" (48.26 cm.) high x 16.65"

(42.29 cm.) wide x 5.20" (13.34 cm.) deep. **Trim Ring (TR-CE-B):** 22.00" (55.88 cm.) high x 19.65" (49.91 cm.) wide.

Shipping Specifications

Weight: 26.9 lbs. (12.20 kg.) **Dimensions:** 20.00" (50.80 cm.) high x 22.5" (57.15 cm.) wide x 8.5" (21.59 cm.) deep.

Temperature and Humidity Ranges

This system meets NFPA requirements for operation at 0 – 49°C/32 – 120°F and at a relative humidity 93% ± 2% RH (non-condensing) at 32°C ± 2°C (90°F ± 3°F). However, the useful life of the system's standby batteries and the electronic components may be adversely affected by extreme temperature ranges and humidity. Therefore, it is recommended that this system and its peripherals be installed in an environment with a normal room temperature of 15 – 27°C/60 – 80°F.

NFPA Standards

The FireWarden-100-2 Rev 3 complies with the following NFPA 72 Fire Alarm Systems requirements:

- **LOCAL** (Automatic, Manual, Waterflow and Sprinkler Supervisory).
- **AUXILIARY** (Automatic, Manual and Waterflow) (requires 4XTM).
- **REMOTE STATION** (Automatic, Manual, Waterflow and Sprinkler Supervisory) (Where a DACT is not accepted, the alarm, trouble and supervisory relays may be connected to UL 864 listed transmitters. For reverse polarity signaling of alarm and trouble, 4XTM is required.)
- **PROPRIETARY** (Automatic, Manual, Waterflow and Sprinkler Supervisory).
- **CENTRAL STATION** (Automatic, Manual, Waterflow and Sprinkler Supervisory).
- **OT, PSDN** (Other Technologies, Packet-switched Data Network)

Agency Listings and Approvals

The listings and approvals below apply to the basic FireWarden-100-2 Rev 3 control panel. In some cases, certain modules may not be listed by certain approval agencies, or listing may be in process. Consult factory for latest listing status.

- **UL Listed:** S635
- **FM approved**
- **CSFM:** 7165-0028:0235
- **MEA:** 120-06-E, Volume 2

For ULC-listed version, see DN-60600.

NOTIFIER® is a registered trademark of Honeywell International Inc. Wheelock® is a registered trademark of and Exceder™ is a trademark of Cooper Notification.

©2010 by Honeywell International Inc. All rights reserved. Unauthorized use of this document is strictly prohibited.



This document is not intended to be used for installation purposes. We try to keep our product information up-to-date and accurate. We cannot cover all specific applications or anticipate all requirements. All specifications are subject to change without notice.



Made in the U.S. A.

For more information, contact Notifier. Phone: (203) 484-7161, FAX: (203) 484-7118.
www.notifier.com

FDU-80

80 Character Liquid Crystal Display



Annunciators

General

The FDU-80 is a compact, cost-effective, 80 character, backlit LCD Fire Annunciator for use with the NOTIFIER FireWarden-100-2, NFS-640, NFS2-640, and NFS-320 Fire Alarm Control Panels (FACPs). The FDU-80 mimics the display of the control panel and displays complete system point status information. Up to 32 FDU-80s may be connected onto the EIA-485 Terminal Mode port of each control panel. The FDU-80 requires no programming, which saves time during system commissioning.

Features

- 80-character Liquid Crystal Display.
- Mimics all display information from the host panel.
- Control switches for System Acknowledge, Signal Silence, Drill and Reset with enable key.
- System status LEDs for Power, Alarm, Trouble, Supervisory, and Alarm Silenced.
- No programming necessary — FDU-80 connects to the terminal mode port.
- Displays device type identifiers, individual point alarm, trouble or supervisory, zone and custom alpha labels.
- Time and date display field.
- Aesthetically pleasing design.
- May be powered by 24 VDC from the host FACP or by remote power supplies (requires 24 VDC).
- Up to 32 FDU-80 annunciators per FACP.
- Plug-in terminal blocks for ease of installation and service.
- Can be remotely located up to 6,000 feet (1828.8 m) from host control panel.
- Local piezo sounder with alarm and trouble resound.
- Semi-flush-mounts to 2.188"/5.556 cm (minimum) deep, three-gang electrical box (NOTIFIER P/N 10103) or three-gangable electrical switchbox.
- Surface-mounts to NOTIFIER SBB-3 surface backbox.

Operation

The FDU-80 annunciator provides the FACP with point annunciation with full display text on an 80-character LCD display. The FDU-80 also provides an array of LEDs to indicate system status, and also includes control switches for remote control of critical system functions.

The FDU-80 provides the FACP with up to 32 remote serially connected annunciators. All field-wiring terminations on the FDU-80 use removable, compression-type terminal blocks for ease of wiring and circuit testing.

Communication between the FACP and the annunciators is accomplished over an EIA-485 serial interface, which greatly reduces wire and installation cost over traditional systems.

Installation

The FDU-80 can be semi-flush mounted to a 2.188"/5.556 cm (minimum) deep, three-gang electrical box or three-gangable electrical switchboxes. Alternately, an SBB-3 surface backbox is available for surface-mount applications.



6820fdu8.jpg

Agency Listings And Approvals

These listings and approvals apply to the modules specified in this document. In some cases, certain modules or applications may not be listed by certain approval agencies, or listing may be in process. Consult factory for latest listing status.

- **UL Listed:** S635
- **ULC Listed:** CS100
- **MEA Listed:** 245-00-E
- **CSFM:** 7120-0028:209
- **FM Approved**

Ordering Information

FDU-80: 80 character, backlit, LCD Fire Annunciator with control switches for remote control of system functions, and key-switch lock.

10103: Three-gang electrical box, minimum 2.188" (5.556 cm) deep, for semi-flush-mount applications.

SBB-3: Three-gang surface backbox for surface-mount applications.

©2009 by Honeywell International Inc. All rights reserved. Unauthorized use of this document is strictly prohibited.



This document is not intended to be used for installation purposes.
We try to keep our product information up-to-date and accurate.
We cannot cover all specific applications or anticipate all requirements.
All specifications are subject to change without notice.

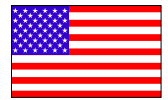

Made in the U.S. A.

For more information, contact Notifier. Phone: (203) 484-7161, FAX: (203) 484-7118.
www.notifier.com



INTRODUCTION

The StarLink™ models **SLE-CDMA-FIRE / SLE-GSM-FIRE** and **SLECDMA-CFB / SLE3/4G-CFB** are fully supervised, sole path approved, commercial cellular fire alarm communicators supported by an extensive nationwide wireless network. Both models are compatible with most 12 or 24VDC Fire Alarm Control Panels with low standby and transmit current draw that allows them to be powered directly from the FACP. Both models are approved for use as sole path primary Fire Alarm communications or as a backup to existing telephone lines. In backup mode, the units will automatically switch the communication channel from the telephone line to the network when a telephone line trouble is detected. For Commercial installations, mount the unit to a single-, dual-, or three-gang electrical box and route the wires through the back knockout(s), or as specified by local codes. **See WI2140 for programming information.**

STARLINK RADIO REPORTING PATH

The diagram below shows the transmission path of a signal from the StarLink radio to the central station.

1. **Signal from a Control Panel.**
2. **StarLink** radio receives the signal transmission (from the TIP and RING wires); sends RF signal through the GPRS network operator.
3. **Network Operator**, part of the vendor system, a section of the cellular spectrum.
4. **SLE Network Operations Center**, receives / routes data.
5. **Central Station.**

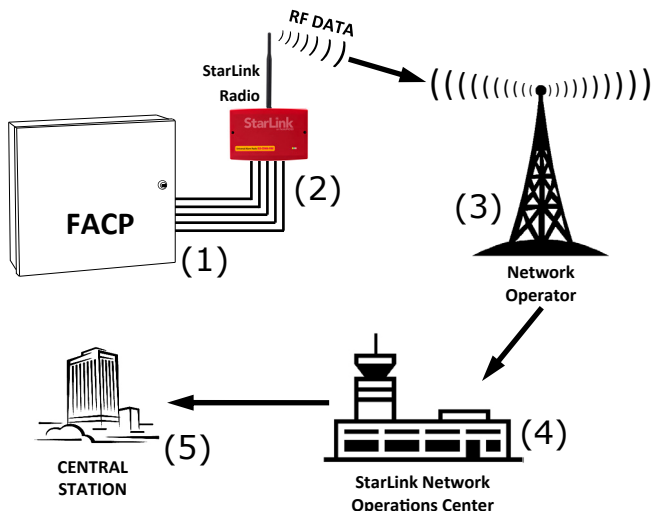

SLE-CDMA-FIRE

SLE-GSM-FIRE

SLECDMA-CFB

SLE3/4G-CFB

Commercial Fire Series Alarm Communicators Submittal Data Sheet

The SLE Series radios use proprietary data-capture technology that captures the alarm report from the control panel and transmits the alarm signals to the SLE Network Operations Center; the alarm signals are then forwarded to ANY central station via Contact ID or Sur-Gard System II via TCP/IP using standard line security. The SLE Network Operations Center reports a trouble signal in the event that the network does not receive the expected supervision signal from the wireless communicator. In addition, all models are powered directly from the control panel.

SLE-CDMA-FIRE / SLE-GSM-FIRE

Commercial / Residential Fire and Burglary CDMA / GSM radio in red plastic enclosure. Rated 12/24VDC input.



SLECDMA-CFB / SLE3/4G-CFB

Commercial / Residential Fire and Burglary CDMA / GSM radio in red metal housing. Powered directly from the control panel, rated 12/24VDC input.



FIRE ALARM COMPATABILITY

The StarLink™ models **SLE-CDMA-FIRE / SLE-GSM-FIRE** and **SLECDMA-CFB / SLE3/4G-CFB** communicators are compatible with any FACP that has a regulated 12 or 24VDC output with sufficient standby current to provide 71mA in standby mode, and 200mA in transmit mode (momentary). The FACP must be equipped with a DACT that transmits central station reports in Contact ID or 4/2 central station formats. The control panel may also trigger communication events through the use of FACP dry contacts connecting the (3) radio inputs, capable of transmitting (4) distinct alarm and trouble event reports to the central station.

ADDITIONAL COMPONENTS

In addition to the models listed above, the following accessories are available and permitted by UL:

SLE-DLCBL - Download Cable, 6 feet.

SLE-ANTEXT - Extended antenna with 15 feet of cable.

Note: Use the SLE-ANTEXT or any other External Antenna intended for the 824-894MHz and 1850-1990MHz bands.

SPECIFICATIONS

The following applies to all StarLink radio models unless otherwise stated:

Electrical Ratings (all models powered by control panel)

- Input Voltage: 12-25VDC regulated (power-limited output from Listed control panel)
- Input Current: 71mA with peak RF transmission current of 200mA

Electrical Ratings for the IN 1 Burg/Fire Input:

- Input Voltage: 9-15VDC regulated. **Note:** Models are rated 9-25VDC input
- Maximum Input Current: Up to 2mA from FACP NAC circuit

Electrical Ratings for IN 2 and IN 3:

- Maximum Loop Voltage: 15VDC. **Note:** Models are rated max 25VDC input
- Maximum Loop Current: 1.2mA
- End of Line Resistor (EOLR) Value: 10K (2 req'd)

Electrical Ratings for 3 PGM Outputs:

- Open Collector Outputs: Maximum Voltage 3V when active; 15V maximum when not active. **Note:** Models are rated max 25VDC output

- Maximum PGM Sink Current: 50mA (up to 15VDC), 25mA (15.1VDC - 25VDC)

Plastic Housings Physical

- W x H x D: 8 x 5⁻²⁹/₆₄ x 1½" (20.3 x 13.9 x 3.8cm)
- Mounting: Plastic housing includes 3 keyhole slots for mounting to single-, dual-, or three-gang electrical boxes

Metal Housings Physical

- W x H x D: 11½ x 9½ x 3½" (29.2 x 24.1 x 8.9cm)
- Mounting: Metal housing includes two keyhole slots for wall mounting (see WI for measurements)

Environmental

- Operating Temperature: 0°C - 49°C (32°F - 120°F)
- Humidity: Maximum 93% Non-Condensing
- Indoor / dry location use only



AGENCY LISTINGS

- UL864 9th Edition: Commercial Fire
- UL985: Household Fire Warning System Units
- UL1023: Household Burglar Alarm System Units
- UL1610: Central Station Burglar Alarm Units
- NFPA 72 National Fire Alarm Code
- CSFM: California State Fire Marshall (Fire Systems Only)
- NYCFD: NYC Fire Department (Fire Systems Only), COA #6213

CDMA models are *Verizon® Network Certified*
3/4G models are *AT&T Accepted / Certified*

NOTICE TO AUTHORITIES HAVING JURISDICTION, USERS, INSTALLERS, DEALERS, AND OTHER AFFECTED PARTIES

FIRE PROGRAMMING OPTION	PERMITTED IN UL864? (Y/N)	AVAILABLE SETTINGS	REQUIRED UL 864 SETTINGS
Unattended Remote Downloading	No	Enable / Disable	Disabled (Jumper 1 installed). Also required for Commercial / Burglary installations. Note: See Installation Instructions section " Configuration Download / Firmware Updates " for jumper instructions.
IN2 and IN3 Unsupervised	No	Supervised / Unsupervised	Supervised (Jumpers 4 and 5 installed)
Radio Path Supervision	No	200 seconds, 5 minutes, 60 minutes, 7 days	200 seconds (UL 864 / UL 1610), 5 minutes (UL 864 9th edition), 60 minutes (UL 864 10th edition), 7 days (UL 985 / UL 1023)

*For Commercial Fire installations, a UL Listed Fire Alarm regulated power supply or FACP regulated auxiliary output is required.

NOT-BG12LX

Addressable Manual Pull Station



Intelligent/Addressable Devices

General

The Notifier NOT-BG12LX is a state-of-the-art, dual-action (i.e., requires two motions to activate the station) pull station that includes an addressable interface for FireWarden series intelligent control panels. Because the NOT-BG12LX is addressable, the control panel can display the exact location of the activated manual station. This leads fire personnel quickly to the location of the alarm.

Features

- Maintenance personnel can open station for inspection and address setting without causing an alarm condition.
- Built-in bicolor LED, which is visible through the handle of the station, flashes in normal operation and latches steady red when in alarm.
- Handle latches in down position and the word “ACTIVATED” appears to clearly indicate the station has been operated.
- Captive screw terminals wire-ready for easy connection to SLC loop (accepts up to 12 AWG/3.25 mm² wire).
- Can be surface mounted (with SB-10 or SB-I/O) or semi-flush mounted. Semi-flush mount to a standard single-gang, double-gang, or 4" (10.16 cm) square electrical box.
- Smooth dual-action design.
- Meets ADAAG controls and operating mechanics guidelines (Section 4.1.3[13]); meets ADA requirement for 5 lb. maximum activation force.
- Highly visible.
- Attractive shape and textured finish.
- Key reset.
- Includes Braille text on station handle.
- Optional trim ring (BG12TR).
- Meets UL 38, Standard for Manually Actuated Signaling Boxes.

Construction

Shell, door, and handle are molded of durable LEXAN® (or polycarbonate equivalent) with a textured finish.

Specifications

- Normal operating voltage: 24 VDC.
- Maximum SLC loop voltage: 28.0 VDC.
- Maximum SLC loop current: μ A.
- Ambient Temperature: 32°F to 120°F (0°C to 49°C)
- Relative Humidity: 93% \pm 2% RH (noncondensing) at 32°C \pm 2°C (90°F \pm 3°F)
- For use indoors in a dry location

Installation

The NOT-BG12LX will mount semi-flush into a single-gang, double-gang, or standard 4" (10.16 cm) square electrical outlet box, or will surface mount to the model SB-10 or SB-I/O surface backbox. If the NOT-BG12LX is being semi-flush mounted, then the optional trim ring (BG12TR) may be used. The BG12TR is usually needed for semi-flush mounting with 4" (10.16 cm) or double-gang boxes (not with single-gang boxes).



The NOT-BG12LX
Addressable Manual Pull Station

Operation

Pushing in, then pulling down on the handle causes it to latch in the down/activated position. Once latched, the word “ACTIVATED” (in bright yellow) appears at the top of the handle, while a portion of the handle protrudes from the bottom of the station. To reset the station, simply unlock the station with the key and pull the door open. This action resets the handle; closing the door automatically resets the switch.

Each manual station, on command from the control panel, sends data to the panel representing the state of the manual switch. Two rotary decimal switches allow address settings (1 – 99 on FireWarden-100-2, 1 – 50 for FireWarden-50).

Architectural/Engineering Specifications

Manual Fire Alarm Stations shall be non-coded, with a key-operated reset lock in order that they may be tested, and so designed that after actual Emergency Operation, they cannot be restored to normal except by use of a key. An operated station shall automatically condition itself so as to be visually detected as activated. Manual stations shall be constructed of red-colored LEXAN (or polycarbonate equivalent) with clearly visible operating instructions provided on the cover. The word FIRE shall appear on the front of the stations in white letters, 1.00 inches (2.54 cm) or larger. Stations shall be suitable for surface mounting on matching backbox SB-10 or SB-I/O; or semi-flush mounting on a standard single-gang, double-gang, or 4" (10.16 cm) square electrical box, and shall be installed within the limits defined by the Americans with Disabilities Act (ADA) or per national/local requirements. Manual Stations shall be Underwriters Laboratories listed.

Manual stations shall connect with two wires to one of the control panel SLC loops. The manual station shall, on command from the control panel, send data to the panel representing the state of the manual switch. Manual stations shall provide address setting by use of rotary decimal switches.

BG12TR: Optional trim ring.

17021: Keys, set of two.

Product Line Information

NOT-BG12LX: Dual-action addressable pull station. Includes key locking feature.

SB-10: Surface backbox; metal.

SB-I/O: Surface backbox; plastic.

Agency Listings and Approvals

In some cases, certain modules or applications may not be listed by certain approval agencies, or listing may be in process. Consult factory for latest listing status.

- **UL Listed:** S692
- **MEA:** 67-02-E Vol. IV
- **CSFM:** 7150-0028:199
- **FM Approved**

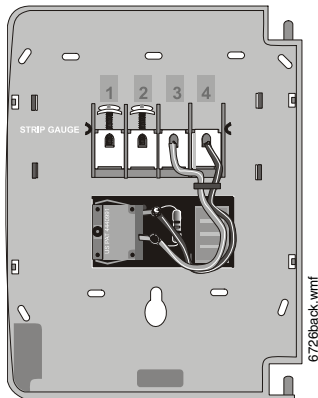

Back of station without door

Terminal Connections:
1 SLC (-); 2 SLC (+)

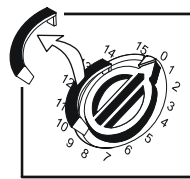

**Detail of
BREAKAWAY TAB***

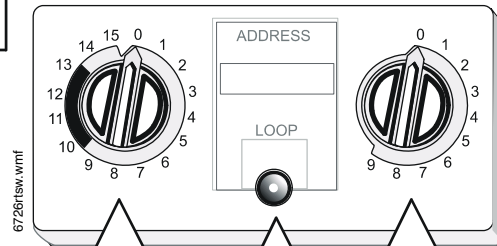

ROTARY DECIMAL SWITCHES

*Do not remove tab.

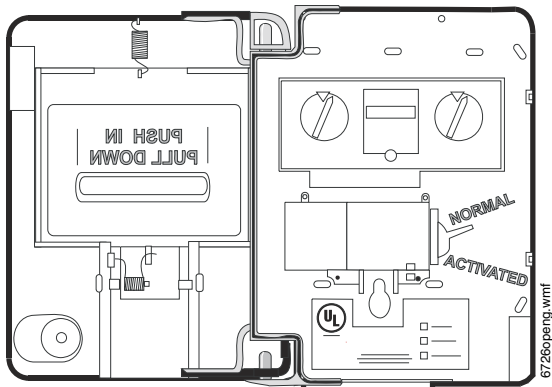

Cover open to show easy access to miniature monitor module, rotary switch, and UL label.

Patented:

U.S. Patent No. D428,351; 6,380,846; 6,314,772; 6,632,108.

Notifier® is a registered trademark of Honeywell International Inc. LEXAN® is a registered trademark of GE Plastics, a subsidiary of General Electric Company.

©2008 by Honeywell International Inc. All rights reserved. Unauthorized use of this document is strictly prohibited.



This document is not intended to be used for installation purposes. We try to keep our product information up-to-date and accurate. We cannot cover all specific applications or anticipate all requirements. All specifications are subject to change without notice.



Made in the U.S. A.

For more information, contact Notifier. Phone: (203) 484-7161, FAX: (203) 484-7118.
www.notifier.com

NP-100(A) Series

Addressable Photoelectric Detectors for the FireWarden Series



Addressable

General

The NP-100(A), NP-100T(A) and NP-100R(A) addressable, low-profile plug-in photoelectric detectors use a state-of-the-art photoelectric sensing chamber with communications to provide open area protection and are used exclusively with NOTIFIER's FireWarden Series (FireWarden-100-2 and FireWarden-50) and Spartan (NSP-25) Addressable Fire Alarm Control Panels (FACPs). The NP-100T(A) adds thermal sensors that will alarm at a fixed temperature of 135°F (57°C). Since these detectors are addressable, they will help emergency personnel quickly locate a fire during its early stages, potentially saving precious rescue time while also reducing property damage. Two LEDs on each sensor light to provide a local, visible sensor indication. Remote LED annunciator capability is available as an optional accessory, PN RA100Z(A). The NP-100R(A) is a remote test capable detector for use with DNR(A)/DNRW duct smoke detector housings.



NP-100(A) in B210LP(A) Base

B210-2851.jpg

Features

SLC loop

- Two-wire loop connection.
- Unit uses base for wiring.

Addressing

- Addressable by device.
- Rotary, decimal addressing: 01 – 99 with FireWarden-100-2 and NSP-25, and 01 – 50 with FireWarden-50.

Architecture

- Unique single-source, dual-chamber design to respond quickly and dependably to a broad range of fires.
- Sleek, low-profile design.
- Integral communications and built-in type identification.
- Built-in tamper-resistant feature.
- Removable cover and insect-resistant screen for simple field cleaning.

Operation

- Withstands air velocities up to 4,000 feet-per-minute (20 m/sec.) without triggering a false alarm.
- Factory preset at 1.5% nominal sensitivity for panel alarm threshold level.
- Visible LED “blinks” when the unit is addressed (communicating with the fire panel) and latches on in alarm.

Mechanicals

- Sealed against back pressure.
- Direct surface mounting or electrical box mounting.
- Mounts to: single-gang box, 3.5" (8.89 cm) or 4.0" (10.16 cm) octagonal box, or 4.0" (10.16 cm) square electrical box (using a plaster ring — included).

Other system features

- Fully coated circuit boards and superior RF/transient protection.
- 94-V0 plastic flammability rating.
- Low standby current.

Options

- Remote LED output connection, PN RA100Z(A).

Applications

Use photoelectric detectors in life-safety applications to provide a broad range of fire-sensing capability, especially where smoldering fires are anticipated. Ionization detectors are often better than photoelectric detectors at sensing fast, flaming fires.

Construction

These detectors are constructed of off-white fire resistant plastic. NP-100(A) series plug-in, low-profile smoke detectors are designed to commercial standards and offer an attractive appearance.

Installation

NP-100(A) series plug-in detectors use a detachable mounting base to simplify installation, service and maintenance.

Mount base (all base types) on an electrical backbox which is at least 1.5" (3.81 cm) deep. For a chart of compatible junction boxes, see DN-60054.

NOTE: Because of the inherent supervision provided by the SLC loop, end-of-line resistors are not required. Wiring “T-taps” or branches are permitted for Style 4 (Class B) wiring. NP-100R(A) mounts in a DNR(A)/DNRW duct detector housing.

Operation

Each NP-100(A) series detector uses one of 99 possible addresses on the FireWarden-100-2 and NSP-25, or one of 50 possible addresses on the FireWarden-50 Signaling Line Circuit (SLC). It responds to regular polls from the system and reports its type and status.

The addressable photoelectric sensor in the NP-100(A) series has a unique unipolar chamber that responds quickly and uniformly to a broad range of smoke conditions. It can withstand wind gusts up to 4,000 feet-per-minute (20 m/sec.) without sending an alarm level signal. Because of its unipolar chamber, the NP-100(A) series is approximately two times more responsive than most photoelectric sensors. This makes it a more stable detector.

Detector Sensitivity Test

Each detector can have its sensitivity tested (required per NFPA 72, Chapter 14 on *Inspection, Testing and Maintenance*) when installed/connected to a FireWarden-100-2 or FireWarden-50 addressable fire alarm control panel. The results of the sensitivity test can be printed off the FireWarden-100-2 or FireWarden-50 for record keeping.

Specification

Voltage range: 15 – 32 VDC (peak).

Standby current: 300 µA @ 24 VDC.

LED current: 6.5 mA @ 24 VDC (latched “ON”).

Air velocity: 4,000 ft./min. (20 m/sec.) maximum.

Size: 2.1" (5.33 cm) high; base determines diameter.

- **B210LP(A):** 6.1" (15.5 cm) diameter.
- **B501(A):** 4.1" (10.4 cm) diameter.
- **B200SR(A):** 6.875" (17.46 cm) diameter.
- **B224RB(A):** 6.2" (15.748 cm) diameter.

Weight: 3.6 oz. (102 g).

Operating temperature range: for **NP-100(A):** 0°C to 49°C (32°F to 120°F); for **NP-100T(A):** 0°C to 38°C (32°F to 100°F). **NP-100R(A):** installed in a DNR(A)/DNRW -20°C to 70°C (-4°F to 158°F).

Temperature: 0°C – 49°C (32°F – 120°F).

Relative humidity: 10% – 93%, non-condensing.

Listings

Listings and approvals below apply to the NP-100(A), NP-100T(A), and NP-100R(A) detectors. In some cases, certain modules may not be listed by certain approval agencies, or listing may be in process. Consult factory for latest listing status.

- **UL Listed:** S1115.
- **ULC Listed:** S911.
- **CSFM:** 7272-0028:0231.
- **MEA:** 243-02-E Vol. 2.
- **Maryland State Fire Marshal:** permit 2173.
- **FM approved.**

Product Line Information

NOTE: “A” suffix indicates ULC Listed model.

NP-100: Addressable photoelectric detector; B210LP base included.

NP-100A: Same as NP-100 with ULC Listing; B210LPA base included.

NP-100T: Same as NP-100 but with **thermal** element; B210LP base included.

NP-100TA: Same as NP-100T with ULC Listing; B210LPA base included.

NP-100R: Remote test capable addressable photoelectric detector for use with a DNRA/DNRW duct detector housing; B210LP base included.

NP-100RA: Same as NP-100R with ULC Listing for use with a DNRA duct detector housing; B210LPA base included.

INTELLIGENT BASES

NOTE: “A” suffix indicates ULC Listed model.

NOTE: For details about intelligent bases and their mounting, see DN-60054.

B210LP(A): Plug-in detector base (included); standard U.S. flanged low-profile mounting base.

B210LPBP: Bulk pack of B210LP; package contains 10.

B501(A): Standard European flangeless mounting base.

B501BP: Bulk pack of B501; package contains 10.

B200SR(A): Intelligent sounder base capable of producing sound output with ANSI Temporal 3 or continuous tone. Replaces B501BH series bases in retrofit applications.

B224RB(A): Plug-in System Sensor **relay** base. Screw terminals: up to 14 AWG (2.0 mm²). Relay type: Form-C. Rating: 2.0 A @ 30 VDC resistive; 0.3 A @ 110 VDC inductive; 1.0 A @ 30 VDC inductive.

B224BI(A): Plug-in System Sensor **isolator** detector base. Maximum 25 devices between isolator bases (see DN-6994).

ACCESSORIES

F110: Retrofit flange to convert B210LP(A) to match the B710LP(A) profile, or to convert older high-profile bases to low-profile.

F110BP: Bulk pack of F110; package contains 15.

F210: Replacement flange for B210LP(A) base.

RA100Z(A): Remote LED annunciator. 3 – 32 VDC. Mounts to a U.S. single-gang electrical box. For use with B501(A) and B210LP(A) bases only.

SMB600: Surface mounting kit

M02-04-00: Test magnet.

M02-09-00: Test magnet with telescoping handle.

XR2B: Detector removal tool. Allows installation and/or removal of detector heads from bases in high ceiling applications.

XP-4: Extension pole for XR2B. Comes in three 5-foot (1.524 m) sections.

T55-127-010: Detector removal tool without pole.

BCK-200B: Black detector covers for use with NP-100(A) only; box of 10.

WCK-200B: White detector covers for use with NP-100(A) only; box of 10.

NOTIFIER® and FireWarden® are registered trademarks of Honeywell International Inc.
©2011. All rights reserved. Unauthorized use of this document is strictly prohibited.



This document is not intended to be used for installation purposes.
We try to keep our product information up-to-date and accurate.
We cannot cover all specific applications or anticipate all requirements.
All specifications are subject to change without notice.



Made in the U.S. A.

For more information, contact Notifier. Phone: (203) 484-7161, FAX: (203) 484-7118.
www.notifier.com

NH-100(A) Series

Intelligent Addressable Thermal Detectors for FireWarden Series



Addressable

General

The **NOTIFIER NH-100(A) Series** thermal detectors are addressable sensors that use a state-of-the-art thermistor sensing circuit for fast response. These sensors provide open-area protection and are intended for use with the **FireWarden Series** (FireWarden-100-2 and FireWarden-50) and **Spartan Series** (NSP-25) addressable Fire Alarm Control Panels (FACPs).

The **NH-100(A)** and **NH-100R(A)** sensors provide fixed temperature alarm detection at 135°F (57°C). The **NH-100R(A)** sensor also responds to rate-of-rise conditions of greater than 15°F (8.3°C) per minute. The **NH-100H(A)** is a fixed high-temperature detector that activates at 190°F (88°C). These thermal detectors provide addressable property protection in a variety of applications.

Two LEDs on each sensor light to provide a local, visible sensor indication. Remote LED annunciator capability is available as an optional accessory, RA100Z.

Features

SLC loop:

- Two-wire SLC loop connection.
- Unit uses base for wiring.

Addressing:

- Addressable by device.
- Rotary, decimal addressing: 01 – 99 with FireWarden-100-2, NSP-25, 01 – 50 with FireWarden-50.

Architecture:

- Sleek, low-profile, stylish design.
- State-of-the-art thermistor technology for fast response.
- Integral communications and built-in device-type identification.
- Built-in tamper resistant feature.
- Built-in functional test switch activated by external magnet.

Operation:

- Factory preset at 135°F (57°C) for the NH-100(A) and NH-100R(A); 190°F (88°C) for the NH-100H(A).
- Rate-of-rise triggers at 15°F (8.3°C) per minute for the NH-100R(A).
- 360°-field viewing angle of the visual alarm indicators (two bicolor LEDs). LEDs blink green in Normal condition and turn on steady red in Alarm.
- Visible LEDs “blink” every time the unit is addressed.

Mechanicals:

- Sealed against back pressure.
- SEMS screws for wiring of the separate base.
- Designed for direct-surface or electrical-box mounting.
- Plugs into separate base for ease of installation and maintenance.
- Separate base allows interchange of photoelectric, ionization and thermal sensors.

Other system features:

- Remote test feature from the panel.
- Walk test with address display.



NH-100(A) in B210LP(A) Base

B210-2251.jpg

- Low standby current.
- 94-5V plastic flammability rating.

Options:

- Remote LED output connection to optional RA100Z remote LED annunciator.
- Flanged surface mounting kit.

Installation

NH-100(A) Series plug-in intelligent thermal detectors use a detachable base to simplify installation, service and maintenance. Installation instructions are shipped with each detector.

Mount base (all base types) on an electrical backbox which is at least 1.5" (3.81 cm) deep. For a chart of compatible junction boxes, see *DN-60054*.

NOTE: Because of the inherent supervision provided by the SLC loop, end-of-line resistors are not required. Wiring “T-taps” or branches are permitted for Style 4 (Class “B”) wiring only.

Applications

Use thermal detectors for protection of property.

Construction

These detectors are constructed of off-white fire-resistant plastic. The NH-100(A) Series plug-in intelligent thermal detectors are designed to commercial standards and offer an attractive appearance.

Operation

Each NH-100(A) Series detector uses one of 99 (FireWarden-100-2, NSP-25) or 50 (FireWarden-50) possible addresses on a control panel SLC loop. It responds to regular polls from the control panel and reports its type and the status. If it receives a test command from the panel (or a local magnet test), it stimulates its electronics and reports an alarm. It blinks its LEDs when polled and turns the LEDs on when commanded by the panel. The NH-100(A) Series offers features and performance that represent the latest in thermal detector technology.

Specifications

Size: 2.1" (5.3 cm) high; base determines diameter.

- **B210LP(A):** 6.1" (15.5 cm) diameter.
- **B501(A):** 4.1" (10.4 cm) diameter.
- **B200SR(A):** 6.875" (17.46 cm) diameter.
- **B224RB(A):** 6.2" (15.748 cm) diameter.

Shipping weight: 4.8 oz. (137 g).

Installation temperature:

- NH-100(A), NH-100R(A): –4°F to 100°F (–20°C to 38°C).
- NH-100H(A): –4°F to 150°F (–20°C to 66°C).

Humidity range: 10% to 93% relative humidity (noncondensing).

Voltage range: 15 to 32 VDC peak.

Standby current: 300 µA @ 24 VDC (one communication every five seconds with LED blink enabled).

LED current: 6.5 mA @ 24 VDC.

Mounting: B210LP(A) flanged base, included. See "Product Line Information: Intelligent Bases" if using a different base.

Fixed-temperature setpoint: 135°F (57°C) for the NH-100 and NH-100R(A)(A); 190°F (88°C) for the NH-100H(A).

Rate-of-rise detection: responds to greater than 15°F (8.3°C) per minute.

Listings and Approvals

Listings and approvals below apply to the NH-100(A) Series detectors. In some cases, certain modules may not be listed by certain approval agencies, or listing may be in process. Consult factory for latest listing status.

- **UL Listed:** S747.
- **ULC Listed:** S747.
- **CSFM:** 7270-0028:0234.
- **MEA:** 387-02-E Vol. II.
- **FM approved.**

Product Line Information

NOTE: "A" suffix indicates ULC Listed model.

NH-100: Intelligent thermal sensor; 135° F (57° C); B210LP base included.

NH-100A: Same as NH-100 but with ULC Listing; B210LPA base included.

NH-100R: Same as NH-100 with *rate-of-rise* feature; B210LP base included.

NH-100RA: Same as NH-100R but with ULC Listing; B210LPA base included.

NH-100H: Intelligent fixed high-temperature thermal detector; 190° F (88° C); B210LP base included.

NH-100HA: Same as NH-100H but with ULC Listing; B210LPA base included.

INTELLIGENT BASES

NOTE: "A" suffix indicates ULC Listed model.

NOTE: For details about intelligent bases and their mounting, see DN-60054.

B210LP(A): Plug-in detector base (included); standard U.S. flanged low-profile mounting base.

B210LPBP: Bulk pack of B210LP; package contains 10.

B501(A): Standard European flangeless mounting base.

B501BP: Bulk pack of B501; package contains 10.

B200SR(A): Intelligent sounder base capable of producing sound output with ANSI Temporal 3 or continuous tone. Replaces B501BH series bases in retrofit applications.

B224RB(A): Plug-in System Sensor **relay** base. Screw terminals: up to 14 AWG (2.0 mm²). Relay type: Form-C. Rating: 2.0 A @ 30 VDC resistive; 0.3 A @ 110 VDC inductive; 1.0 A @ 30 VDC inductive.

B224BI(A): Plug-in System Sensor **isolator** detector base. Maximum 25 devices between isolator bases (see DN-6994).

ACCESSORIES

F110: Retrofit flange to convert B210LP(A) to match the B710LP(A) profile, or to convert older high-profile bases to low-profile.

F110BP: Bulk pack of F110; package contains 15.

F210: Replacement flange for B210LP(A) base.

RA100Z(A): Remote LED annunciator. 3 – 32 VDC. Mounts to a U.S. single-gang electrical box. For use with B501(A) and B210LP(A) bases only.

SMB600: Surface mounting kit

M02-04-00: Test magnet.

M02-09-00: Test magnet with telescoping handle.

XR2B: Detector removal tool. Allows installation and/or removal of detector heads from bases in high ceiling applications.

XP-4: Extension pole for XR2B. Comes in three 5-foot (1.524 m) sections.

T55-127-010: Detector removal tool without pole.

NOTIFIER® and FireWarden® are registered trademarks of Honeywell International Inc.

©2011. All rights reserved. Unauthorized use of this document is strictly prohibited.



This document is not intended to be used for installation purposes.
We try to keep our product information up-to-date and accurate.
We cannot cover all specific applications or anticipate all requirements.
All specifications are subject to change without notice.



Made in the U.S. A.

For more information, contact Notifier. Phone: (203) 484-7161, FAX: (203) 484-7118.
www.notifier.com

Monitor Modules

NMM-100(A), NMM-100P(A), NZM-100(A), and NDM-100(A) for FireWarden Series Panels



Intelligent Addressable Devices

General

Four different monitor modules are available for Notifier's FireWarden Series intelligent control panels for a variety of applications. Monitor modules supervise a circuit of dry-contact input devices, such as conventional heat detectors and pull stations, or monitor and power a circuit of two-wire smoke detectors (NZM-100(A)).

NMM-100(A) is a standard-sized module (typically mounts to a 4" [10.16 cm] square box) that supervises either a Style D (Class A) or Style B (Class B) circuit of dry-contact input devices.

NMM-100P(A) is a miniature monitor module a mere 1.3" (3.302 cm) H x 2.75" (6.985 cm) W x 0.5" (1.270 cm) D that supervises a Style B (Class B) circuit of dry-contact input devices. Its compact design allows the NMM-100P(A) to be mounted in a single-gang box behind the device it monitors.

NZM-100(A) is a standard-sized module that monitors and supervises compatible two-wire, 24 volt, smoke detectors on a Style D (Class A) or Style B (Class B) circuit.

NDM-100(A) is a standard-sized dual monitor module that monitors and supervises two independent two-wire Style B (Class B) dry-contact initiating device circuits (IDCs) at two separate, consecutive addresses in intelligent, two-wire systems.

NMM-100(A) Monitor Module

- Built-in type identification automatically identifies this device as a monitor module to the control panel.
- Powered directly by two-wire SLC loop. No additional power required.
- High noise (EMF/RFI) immunity.
- SEMS screws with clamping plates for ease of wiring.
- Direct Decade entry of address: 01 – 99 on FireWarden-100-2, 01 – 50 on FireWarden-50.
- LED flashes during normal operation and latches on steady to indicate alarm.

The NMM-100(A) Monitor Module is intended for use in intelligent, two-wire systems, where the individual address of each module is selected using the built-in rotary switches. It provides either a two-wire or four-wire fault-tolerant Initiating Device Circuit (IDC) for normally-open-contact fire alarm and supervisory devices. The module has a panel-controlled LED indicator.

NMM-100(A) APPLICATIONS

Use to monitor a zone of four-wire smoke detectors, manual fire alarm pull stations, waterflow devices, or other normally-open dry-contact alarm activation devices. May also be used to monitor normally-open supervisory devices with special supervisory indication at the control panel. Monitored circuit may be wired as an NFPA Style B (Class B) or Style D (Class A) Initiating Device Circuit. A 47K ohm End-of-Line Resistor (provided) terminates the Style B circuit. No resistor is required for supervision of the Style D circuit.

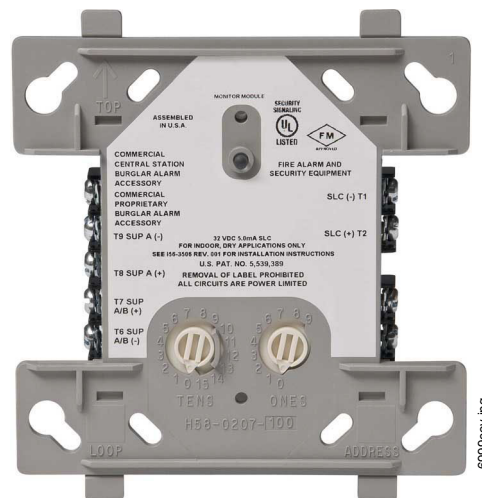

NMM-100(A) (Type H)

NMM-100(A) OPERATION

Each NMM-100(A) uses one of the available module addresses on an SLC loop. It responds to regular polls from the control panel and reports its type and the status (open/normal/short) of its Initiating Device Circuit (IDC). A flashing LED indicates that the module is in communication with the control panel. The LED latches steady on alarm (subject to current limitations on the loop).

NMM-100(A) SPECIFICATIONS

Nominal operating voltage: 15 to 32 VDC.

Maximum current draw: 5.0 mA (LED on).

Average operating current: 350 μ A (LED flashing), 1 communication every 5 seconds, 47k EOL.

Maximum IDC wiring resistance: 40 ohms.

EOL resistance: 47K ohms.

Temperature range: 32°F to 120°F (0°C to 49°C).

Humidity range: 10% to 93% noncondensing.

Dimensions: 4.5" (11.43 cm) high x 4" (10.16 cm) wide x 1.25" (3.175 cm) deep. Mounts to a 4" (10.16 cm) square x 2.125" (5.398 cm) deep box.

NMM-100P(A) Mini Monitor Module

- Built-in type identification automatically identifies this device as a monitor module to the panel.
- Powered directly by two-wire SLC loop. No additional power required.
- High noise (EMF/RFI) immunity.
- Tinned, stripped leads for ease of wiring.
- Direct Decade entry of address: 01 – 99 on FireWarden-100-2, 01 – 50 on FireWarden-50.

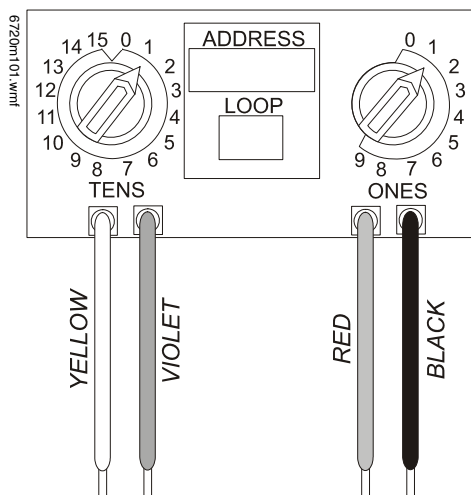

The NMM-100P(A) Mini Monitor Module can be installed in a single-gang junction directly behind the monitored unit. Its small size and light weight allow it to be installed without rigid mounting. The NMM-100P(A) is intended for use in intelligent, two-wire systems where the individual address of each module is selected using rotary switches. It provides a two-wire initiating device circuit for normally-open-contact fire alarm and security devices. NMM-100P(A)

NMM-100P(A) APPLICATIONS

Use to monitor a single device or a zone of four-wire smoke detectors, manual fire alarm pull stations, waterflow devices, or other normally-open dry-contact devices. May also be used to monitor normally-open supervisory devices with special supervisory indication at the control panel. Monitored circuit/device is wired as an NFPA Style B (Class B) Initiating Device Circuit. A 47K ohm End-of-Line Resistor (provided) terminates the circuit.

NMM-100P(A) OPERATION

Each NMM-100P(A) uses one of the available module addresses on an SLC loop. It responds to regular polls from the control panel and reports its type and the status (open/normal/short) of its Initiating Device Circuit (IDC).

NMM-100P(A) SPECIFICATIONS

Nominal operating voltage: 15 to 32 VDC.

Average operating current: 350 μ A, 1 communication every 5 seconds, 47k EOL; 600 μ A Max. (Communicating, IDC Shorted).

Maximum IDC wiring resistance: 40 ohms.

Maximum IDC Voltage: 11 Volts.

Maximum IDC Current: 400 μ A.

EOL resistance: 47K ohms.

Temperature range: 32°F to 120°F (0°C to 49°C).

Humidity range: 10% to 93% noncondensing.

Dimensions: 1.3" (3.302 cm) high x 2.75" (6.985 cm) wide x 0.65" (1.651 cm) deep.

Wire length: 6" (15.24 cm) minimum.

NZM-100(A) Interface Module

- Supports compatible two-wire smoke detectors.
- Supervises IDC wiring and connection of external power source.
- High noise (EMF/RFI) immunity.
- SEMS screws with clamping plates for ease of wiring.
- Direct Decade entry of address: 01 – 99 on FireWarden-100-2, 01 – 50 on FireWarden-50.
- LED flashes during normal operation.
- LED latches steady to indicate alarm on command from control panel.

The NZM-100(A) Interface Module is intended for use in intelligent, addressable systems, where the individual address of each module is selected using built-in rotary switches. This module allows intelligent panels to interface and monitor two-wire conventional smoke detectors. It transmits the status (normal, open, or alarm) of one full zone of conventional detectors back to the control panel. All two-wire detectors being monitored must be UL compatible with the module.

NZM-100(A) APPLICATIONS

Use the NZM-100(A) to monitor a zone of two-wire smoke detectors. The monitored circuit may be wired as an NFPA Style B (Class B) or Style D (Class A) Initiating Device Circuit. A 3.9 K ohm End-of-Line Resistor (provided) terminates the end of the Style B or D (class B or A) circuit (maximum IDC loop resistance is 25 ohms). Install ELR across terminals 8 and 9 for Style D application.

NZM-100(A) OPERATION

Each NZM-100(A) uses one of the available module addresses on an SLC loop. It responds to regular polls from the control panel and reports its type and the status (open/normal/short) of its Initiating Device Circuit (IDC). A flashing LED indicates that the module is in communication with the control panel. The LED latches steady on alarm (subject to current limitations on the loop).

NZM-100(A) SPECIFICATIONS

Nominal operating voltage: 15 to 32 VDC.

Maximum current draw: 5.1 mA (LED on).

Maximum IDC wiring resistance: 25 ohms.

Average operating current: 300 μ A, 1 communication and 1 LED flash every 5 seconds, 3.9k eol.

EOL resistance: 3.9K ohms.

External supply voltage (between Terminals T3 and T4): DC voltage: 24 volts power limited. Ripple voltage: 0.1 Vrms maximum. Current: 90 mA per module maximum.

Temperature range: 32°F to 120°F (0°C to 49°C).

Humidity range: 10% to 93% noncondensing.

Dimensions: 4.5" (11.43 cm) high x 4" (10.16 cm) wide x 1.25" (3.175 cm) deep. Mounts to a 4" (10.16 cm) square x 2.125" (5.398 cm) deep box.

NDM-100(A) Dual Monitor Module

The NDM-100(A) Dual Monitor Module is intended for use in intelligent, two-wire systems. It provides two independent two-wire initiating device circuits (IDCs) at two separate, consecutive addresses. It is capable of monitoring normally open contact fire alarm and supervisory devices. The module has a single panel-controlled LED.

NOTE: The NDM-100(A) provides two Style B (Class B) IDC circuits ONLY. Style D (Class A) IDC circuits are NOT supported in any application.

NDM-100(A) SPECIFICATIONS

Normal operating voltage range: 15 to 32 VDC.

Maximum current draw: 6.4 mA (LED on).

Average operating current: 750 μ A (LED flashing).

Maximum IDC wiring resistance: 1,500 ohms.

Maximum IDC Voltage: 11 Volts.

Maximum IDC Current: 240 μ A

EOL resistance: 47K ohms.

Maximum SLC Wiring resistance: 40 Ohms.

Temperature range: 32° to 120°F (0° to 49°C).

Humidity range: 10% to 93% (non-condensing).

Dimensions: 4.5" (11.43 cm) high x 4" (10.16 cm) wide x 2.125" (5.398 cm) deep.

NDM-100(A) AUTOMATIC ADDRESSING

The NDM-100(A) automatically assigns itself to two addressable points, starting with the original address. For example, if the NDM-100(A) is set to address "26", then it will automatically assign itself to addresses "26" and "27".

NOTE: "Ones" addresses on the NDM-100(A) are 0, 2, 4, 6, or 8 only. Terminals 6 and 7 use the first address, and terminals 8 and 9 use the second address.



CAUTION:

Avoid duplicating addresses on the system.

Installation

NMM-100(A), NZM-100(A), and NDM-100(A) modules mount directly to a standard 4" (10.16 cm) square, 2.125" (5.398 cm) deep, electrical box. They may also be mounted to the SMB500 surface-mount box. Mounting hardware and installation instructions are provided with each module. All wiring must conform to applicable local codes, ordinances, and regulations. These modules are intended for power-limited wiring only.

The NMM-100P(A) module is intended to be wired and mounted without rigid connections inside a standard electrical box. All wiring must conform to applicable local codes, ordinances, and regulations.

Agency Listings and Approvals

In some cases, certain modules may not be listed by certain approval agencies, or listing may be in process. Consult factory for latest listing status.

- **UL:** S635
- **ULC:** S635
- **FM Approved**
- **CSFM:** 7300-0028:0230 (NMM-100, NMM-100P, NZM-100); 7300-0028:0237 (NDM-100)

- **MEA:** 72-01-E Vol. 2 (NMM-100, NMM-100P, NZM-100); 227-03-E Vol. 3 (NDM-100)

Product Line Information

NOTE: "A" suffix indicates ULC-listed model.

NMM-100(A): Monitor module.

NMM-100P(A): Monitor module, miniature.

NZM-100(A): Monitor module, two-wire detectors.

NDM-100(A): Monitor module, dual, two independent Class B circuits.

SMB500: Optional surface-mount backbox.

NOTE: See installation instructions and refer to the SLC Wiring Manual, PN 52304.

Notifier® and FireWarden® are registered trademarks and FireWatch™ is a trademark of Honeywell International Inc.
©2010 by Honeywell International Inc. All rights reserved. Unauthorized use of this document is strictly prohibited.



This document is not intended to be used for installation purposes.
We try to keep our product information up-to-date and accurate.
We cannot cover all specific applications or anticipate all requirements.
All specifications are subject to change without notice.



Made in the U.S. A.

For more information, contact Notifier. Phone: (203) 484-7161, FAX: (203) 484-7118.
www.notifier.com

Indoor Selectable-Output Strobes and Horn Strobes for Ceiling Applications



Audio/Visual Devices

General

System Sensor L-Series audible visible notification products are rich with features guaranteed to cut installation times and maximize profits with lower current draw and modern aesthetics.

The System Sensor L-Series offers the most versatile and easy-to-use line of horns, strobes, and horn strobes in the industry with lower current draws and modern aesthetics. With white and red plastic housings, wall and ceiling mounting options, System Sensor L-Series can meet virtually any application requirement.

The entire L-Series product line of ceiling-mount strobes and horn strobes include a variety of features that increase their application versatility while simplifying installation. All devices feature a plug-in design with minimal intrusion into the back box, making installations fast and foolproof while virtually eliminating costly and time-consuming ground faults.

To further simplify installation, the L-Series utilizes a universal mounting plate so installers can mount them to a wide array of back boxes. With an onboard shorting spring, installers can test wiring continuity before the device is installed.

Installers can also easily adapt devices to suit a wide range of application requirements using field-selectable candela settings, automatic selection of 12- or 24-volt operation, and a rotary switch for horn tones with two volume selections.

Features

- Plug-in design with minimal intrusion into the back box
- Tamper-resistant construction
- Automatic selection of 12- or 24-volt operation at 15 and 30 candela
- Field-selectable candela settings on ceiling units: 15, 30, 75, 95, 115, 150, and 177
- Horn rated at 88+ dBA at 16 volts
- Rotary switch for horn tone and two volume selections
- Universal mounting plate for ceiling units
- Mounting plate shorting spring feature checks wiring continuity before device installation
- Electrically compatible with legacy SpectrAlert and SpectrAlert Advance devices
- Compatible with MDL3 sync module
- Listed for ceiling mounting only



SCRL

PC2WL

Architect/Engineer Specifications

GENERAL

L-Series ceiling-mount strobes and horn strobes shall mount to a standard 4 × 4 × 1½-inch back box, 4-inch octagon back box, or double-gang back box. Two-wire products shall also mount to a single-gang 2 × 4 × 1⅞ inch back box. A universal mounting plate shall be used for mounting ceiling and wall products. The notification appliance circuit wiring shall terminate at the universal mounting plate. Also, L-Series products, when used with the Sync•Circuit™ Module accessory, shall be powered from a non-coded notification appliance circuit output and shall operate on a nominal 12 or 24 volts. When used with the Sync•Circuit Module, 12-volt-rated notification appliance circuit outputs shall operate between 8.5 and 17.5 volts; 24-volt-rated notification appliance circuit outputs shall operate between 16.5 and 33 volts. Indoor L-Series products shall operate between 32 and 120 degrees Fahrenheit from a regulated DC or full-wave rectified unfiltered power supply. Ceiling strobes and horn strobes shall have field-selectable candela settings including 15, 30, 75, 95, 115, 150, and 177.

STROBE

The strobe shall be a System Sensor L-Series Model _____ listed to UL 1971 and shall be approved for fire protective service. The strobe shall be wired as a primary-signaling notification appliance and comply with the Americans with Disabilities Act requirements for visible signaling appliances, flashing at 1 Hz over the strobe's entire operating voltage range. The strobe light shall consist of a xenon flash tube and associated lens/reflector system.

HORN STROBE COMBINATION

The horn strobe shall be a System Sensor L-Series Model _____ listed to UL 1971 and UL 464 and shall be approved for fire protective service. The horn strobe shall be wired as a primary-signaling notification appliance and comply with the Americans with Disabilities Act requirements for visible signaling appliances, flashing at 1 Hz over the strobe's entire operating voltage range. The strobe light shall consist of a xenon flash tube and associated lens/reflector system. The horn shall have two audibility options and an option to switch between a temporal three pattern and a non-temporal (continuous) pattern. These options are set by a multiple position switch. The horn on horn strobe models shall operate on a coded or non-coded power supply.

SYNCHRONIZATION MODULE

The module shall be a System Sensor Sync•Circuit model MDL3 listed to UL 464 and shall be approved for fire protective service. The module shall synchronize L-Series strobes at 1 Hz and horns at temporal three. Also, while operating the strobes, the module shall silence the horns on horn strobe models over a single pair of wires. The module shall mount to a $4^{11/16} \times 4^{11/16} \times 2^{1/8}$ inch back box. The module shall also control two Style Y (class B) circuits or one Style Z (class A) circuit. The module shall synchronize multiple zones. Daisy chaining two or more synchronization modules together will synchronize all the zones they control. The module shall not operate on a coded power supply.

PHYSICAL/ELECTRICAL SPECIFICATIONS

- **Standard Operating Temperature:** 32°F to 120°F (0°C to 49°C)
- **Humidity Range:** 10 to 93% non-condensing
- **Strobe Flash Rate:** 1 flash per second
- **Nominal Voltage:** Regulated 12VDC or regulated 24DC/FWR¹
- **Operating Voltage Range²:** 8 to 17.5V (12V nominal) or 16 to 33V (24V nominal)
- **Operating Voltage Range with MLD3:** 8.5 to 17.5V (12V nominal) or 16.5 to 33V (24V nominal)
- **Input terminal wire gauge:** 12 to 18 AWG
- **Ceiling-Mount Dimensions (including lens):** 6.8" diameter 2.5" high (173 mm diameter 64 mm high)
- **Ceiling-Mount Surface Mount Back Box Skirt Dimensions (SBBCR, SBBCW):** 6.9" diameter x 3.4" high (175 mm diameter x 86 mm high)

Notes:

1. Full Wave Rectified (FWR) voltage is a non-filtered, time varying power source that is used on some power supply and panel outputs.
2. P, S, PC, and SC products will operate at 12 V nominal only for 15 and 30 cd.

UL Current Draw Data

UL MAX. STROBE CURRENT DRAW (MA RMS)

Candela	8–17.5 Volts	16–33 Volts	
	DC	DC	FWR
15	87	41	60
30	153	63	86
75	N/A	111	142
95	N/A	134	164
115	N/A	158	191
150	N/A	189	228
177	N/A	226	264

*This data represents coding at 3 chimes per second. Actual current draw will vary depending upon coding selected.

UL MAX. CHIME/STROBE CURRENT DRAW (MA RMS), 2-WIRE HORN STROBE

Candela	8 VDC		16 VDC						
	15	30	15	30	75	95	115	150	177
EM Temp Hi	103	167	71	90	143	165	187	217	254
EM Temp Low	96	165	54	71	137	161	185	211	249
EM Cont Hi	106	173	71	90	141	165	187	230	273
EM Cont Low	95	166	54	71	124	161	170	216	258
3.1K Temp Hi	111	164	69	94	147	163	184	229	257
3.1K Temp Low	103	163	54	88	143	155	185	212	252
3.1K Cont Hi	111	172	69	94	144	164	202	229	271
3.1K Cont Low	103	169	54	88	131	155	187	217	259

Candela	16VFWR						
	15	30	75	95	115	150	177
EM Temp Hi	107	135	179	198	223	254	286
EM Temp Low	78	101	151	172	199	229	262
EM Cont Hi	107	135	179	198	223	254	286
EM Cont Low	78	101	151	172	199	229	262
3.1K Temp Hi	108	135	179	200	225	255	289
3.1K Temp Low	79	101	150	171	196	229	260
3.1K Cont Hi	108	135	179	200	225	255	289
3.1K Cont Low	79	101	150	171	196	229	260

Horn Strobe Tones and Sound Output Data

HORN AND HORN STROBE OUTPUT (DBA)

Switch Position	Sound Pattern	dB	8-17.5 Volts	16-33 Volts	
			DC	DC	FWR
1	Temporal	High	84	89	89
2	Temporal	Low	75	83	83
3	Non-Temporal	High	85	90	90
4	Non-Temporal	Low	76	84	84
5	3.1 KHz Temporal	High	83	88	88
6	3.1 KHz Temporal	Low	76	82	82
7	3.1 KHz Non-Temporal	High	84	89	89
8	3.1 KHz Non-Temporal	Low	77	83	83

Product Drawings: L-Series Dimensions

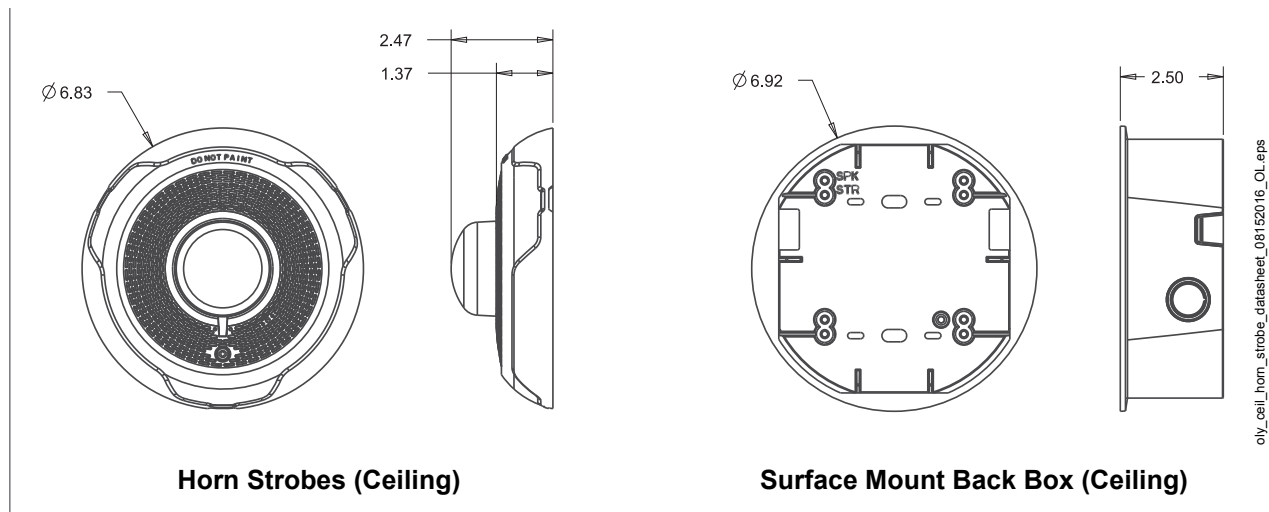

oiv_cel_horn_strobe_datasheet_08152016_OL.eps

Agency Listings and Approvals

The listings and approvals below apply to L-series devices. In some cases, certain modules or applications may not be listed by certain approval agencies, or listing may be in process. Consult factory for latest listing status.

- **UL/ULC-Listed**
 - S4011 Ceiling horn strobes
 - S5512 Ceiling strobes
 - S5512 ALERT strobes with clear lenses
- **FM Approved**

Product Line Information

Note: ULC-listed devices include required French labeling. See Agency Listings for listing details.

CEILING HORN STROBES

PC2WL, **PC2RL**. 2-Wire, Horn Strobe (White, Red).

CEILING STROBES

SCWL, **SCRL**. Strobe (White, Red).

SCWL-CLR-ALERT. Strobe, ALERT (White).

ACCESSORIES

TR-2W, TR-2. Universal Wall Trim Ring (White, Red).

SBBCWL, SBBCRL. Ceiling Surface Mount Back Box (White, Red).

NOTIFIER® and SpectrAlert® are registered trademarks and Sync•Circuit™ is a trademark of Honeywell International Inc. ©2017 by Honeywell International Inc. All rights reserved. Unauthorized use of this document is strictly prohibited.



This document is not intended to be used for installation purposes.
We try to keep our product information up-to-date and accurate.
We cannot cover all specific applications or anticipate all requirements.
All specifications are subject to change without notice.

For more information, contact Notifier. Phone: (203) 484-7161, FAX: (203) 484-7118.
www.notifier.com

BAT Series Batteries

Sealed Lead-Acid



Power Supplies

General

BAT Series Batteries are Power-Sonic brand batteries. BAT Series (or Power-Sonic brand) batteries are recommended for secondary power or backup power for all NOTIFIER fire alarm control equipment.

Features

- Provide secondary power for control panels.
- Sealed and maintenance-free.
- Overcharge protected.
- Easy handling with leak-proof construction.
- Ruggedly constructed, high-impact case (ABS).
- Long service life.
- Compact design.

Agency Listings and Approvals

The listings and approvals below apply to BAT Series Batteries. In some cases, certain modules may not be listed by certain approval agencies, or listing may be in process. Consult factory for latest listing status.

- **UL Recognized Components:** MH20845 (*Power-Sonic*).



6933cov.jpg

Ordering Information

BAT-1250-BP: 10-unit bulk pack of BAT-1250 (12 V 5 AH).

BAT-1270-BP: 5-unit bulk pack of BAT-1270 (12 V 7 AH).

BAT-12120-BP: 4-unit bulk pack of BAT-12120 (12V 12 AH).

BAT-12180-BP: 2-unit bulk pack of BAT-12180 (12 V 18 AH).

BAT-12260-BP: 2-unit bulk pack of BAT-12260 (12 V 26 AH).

BAT-12550: single battery (12 V 55 AH).

BAT-121000: single battery (12 V 100 AH).

Part Number Reference & Specifications

Part Number	Power-Sonic Part Number	Battery Description			DIMENSIONS									
		Nominal Voltage V	Nominal Capacity @ 20 hr. rate A.H.		Width		Depth		Height		Height over terminal		Weight	
					in.	mm	in.	mm	in.	mm	in.	mm	lb.	kg.
BAT-1250	PS-1250	12	5	sealed	3.54	90	2.76	70	3.98	101	4.21	107	3.50	1.59
BAT-1270	PS-1270	12	7	sealed	5.95	151	2.56	65	3.7	94	3.86	98	4.8	2.18
BAT-12120	PS-12120	12	12	sealed	5.95	151	3.86	98	3.7	94	3.94	100	7.92	3.59
BAT-12180	PS-12180	12	18	sealed	7.13	181	3.00	76	6.59	167	6.59	167	12.6	5.72
BAT-12260	PS-12260	12	26	sealed	6.5	167	6.97	177	4.92	125	4.92	125	17	7.71
BAT-12550	PS-12550	12	55	sealed	9.04	230	5.45	138	8.15	207	8.98	228	36	16.33
BAT-121000	PS-121000	12	100	sealed	12	305	6.6	168	8.15	207	8.98	228	68	30.84

Discharge Characteristic Curves at 20°C (68°F)

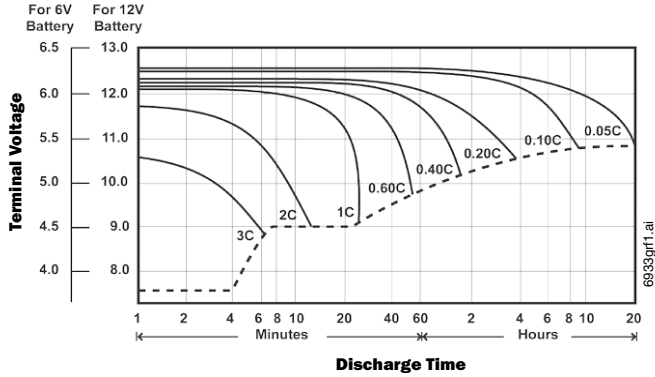

Effect of Temperature on Capacity

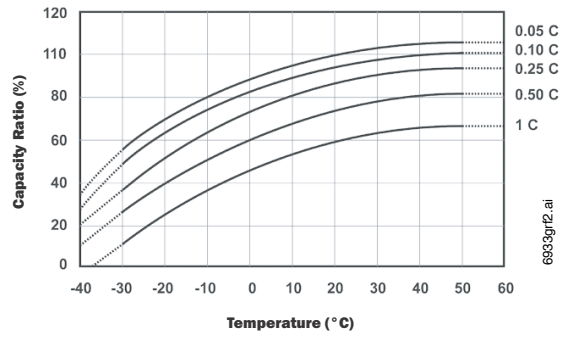

PS-121000 Shelf-Life and Storage

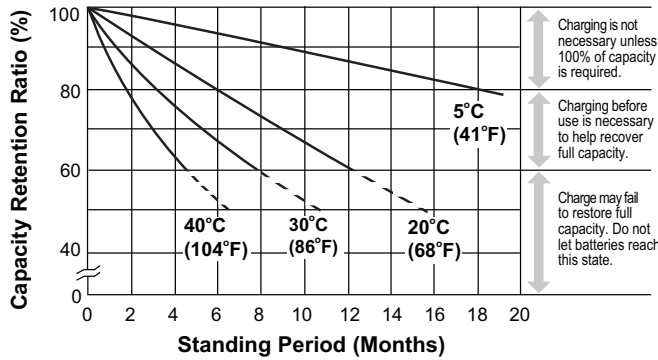

PS-121000 Discharge Characteristics

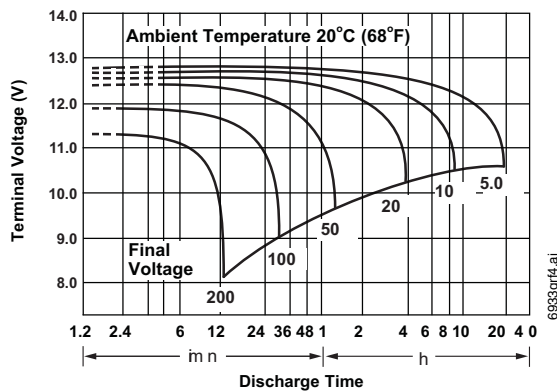

NOTIFIER® is a registered trademark of Honeywell International Inc. Batteries display trademarks of the manufacturer. ©2013 by Honeywell International Inc. All rights reserved. Unauthorized use of this document is strictly prohibited.



This document is not intended to be used for installation purposes. We try to keep our product information up-to-date and accurate. We cannot cover all specific applications or anticipate all requirements. All specifications are subject to change without notice.

For more information, contact Notifier. Phone: (203) 484-7161, FAX: (203) 484-7118. www.notifier.com